

A. Technical Specifications

SL. No	Description and Technical Specification of the item	QTY	UNIT	Delivery
1	<p>CONTACT TIP ID 0.9MM STBW -UNIWELD M/C</p> <p>Contact Tip 0.9MM (M8X1.25) for STBW-UNIWELD machine as per Per Drawing Number 4M-10A-11-26913/01 SL.NO .1.</p> <p>Chromium Zirconium Copper Cu - 99.0% minimum. Cr - 0.65% minimum. Zr - 0.08% minimum.</p> <p>NOTE: Contact Tip Hole Diameter 0.9 To Be Engraving On Top Surface.</p> <p>Material test certificate is required along with supply.</p>	24,000.00	NO	90 DAYS
2	<p>CONTACT TIP DIA 3.4MM, SAW</p> <p>As per drawing number 4M-10A-15-25070/02. S.L.NO.2 (Diameter 3.4).</p> <p>Material Test Certificate is required along with supply.</p>	400.00	NO	90 DAYS
3	<p>CONTACT TIP 505 FOR 20 TORCH DRUM PACK</p> <p>CONTACT TIP(M8X1.25) DIA 1.25 MM (FOR FEEDING 1.2 MM WIRE) 20-TORCH DRUM PACK AS PER DRG NO.4M-10A54-27700/02 [SL.NO.1]</p> <p>CHEMICAL COMPOSITION AS BELOW: CHROMIUM ZIRCONIUM COPPER AS PER USA-UNS CrZr. Cu - 99.0% MINIMUM Cr - 0.65% MINIMUM Zr - 0.08% MINIMUM</p> <p>TEST CERTIFICATE IN ENGLISH FOR CHEMICAL ANALYSIS IS REQUIRED WITH SUPPLY.</p>	4,500.00	NO	90 DAYS

4	CONTACT TIP DIA 4.2MM, SAW CONTACT TIP(SAW) Diameter 4.2 MM S.L.NO.3 (Diameter 4.2) As per drawing number 4M-10A-15-25070/02. Material Test Certificate is required along with supply.	800.00	NO	90 DAYS
---	---	--------	----	---------

CAUTION: THIS DRAWING IS OUR SOLE PROPERTY AND SHOULD NOT BE USED IN ANY FORM FOR ANY PURPOSE WITHOUT THE WRITTEN PERMISSION OF BHARAT HEAVY ELECTRICALS LIMITED TRICHIRAPPALLI - 620 014.

ALL DIMENSIONS ARE IN MM

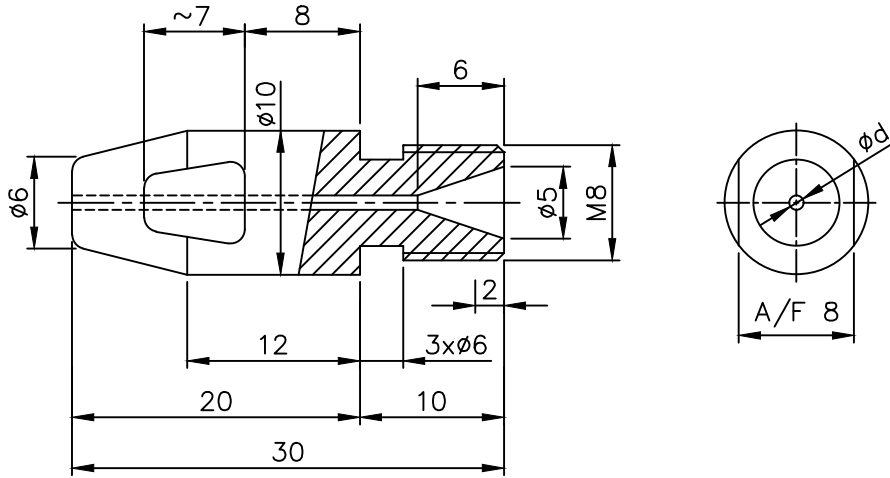

SL.NO	ϕd	FOR WIRE ϕ
1	$0.9^{+0.04}_{-0.00}$	CS&ALLOY 0.8mm
2	$0.98^{+0.00}_{-0.01}$	SS&INCONEL 0.8mm
3	$1.20^{+0.04}_{-0.00}$	SUPER 304 H&T92 1.0mm

* CHROMIUM ZIRCONIUM COPPER

AS PER USA-UNS Cr.Zr.

Cr.-0.65% Min

Zr.-0.08% Min

Cu.-99% Min

NOTE: -

01. HOLE ϕd , TO BE DONE THROUGHTOUT IN SINGLE DIRECTION AND IN SINGLE SETTING
02. HOLE ϕd TO BE ENGRAVED AT THE TOP OF THE CONTACT TIP.
03. SHARP CORNERS TO BE REMOVED.

X		$\phi 10 \times 30L$	UNS Cr.Zr.*	USA			
No. of Pieces	DESCRIPTION		MATERIAL	STANDARD	NET.WT.IN KGS.	DRAWING No.	ITEM No.
	REFERENCE:		ALTERATIONS:		DCN REF	DATE	SIGN.
SCALE	DRAWN/TCD	<i>N.MANOJ</i>	MATERIAL COMP.&SL.NO.03 ADDED			06.01.2'	CSJ
2:1	CHECKED	R.Ramamoorthy					
	APPROVED	C.S.Jayasheelan					
	DATE	24-06-02/11-11-08					
MACHINE: STRIGHT TUBE BUTT WELDER.		TYPE: STBWD					
TITLE: CONTACT TIP		DRAWING No:		REV.			
		4M10A1		1 26913		01	
Sheet No:		No. of Sheets:					

THIS DRAWING IS OUR SOLE PROPERTY AND SHOULD NOT BE USED IN ANY FORM FOR ANY PURPOSE WITHOUT THE WRITTEN PERMISSION OF BHARAT HEAVY ELECTRICALS LIMITED TRICHIRAPPALLI - 620 014.

ALL DIMENSIONS ARE IN MM

1.6/

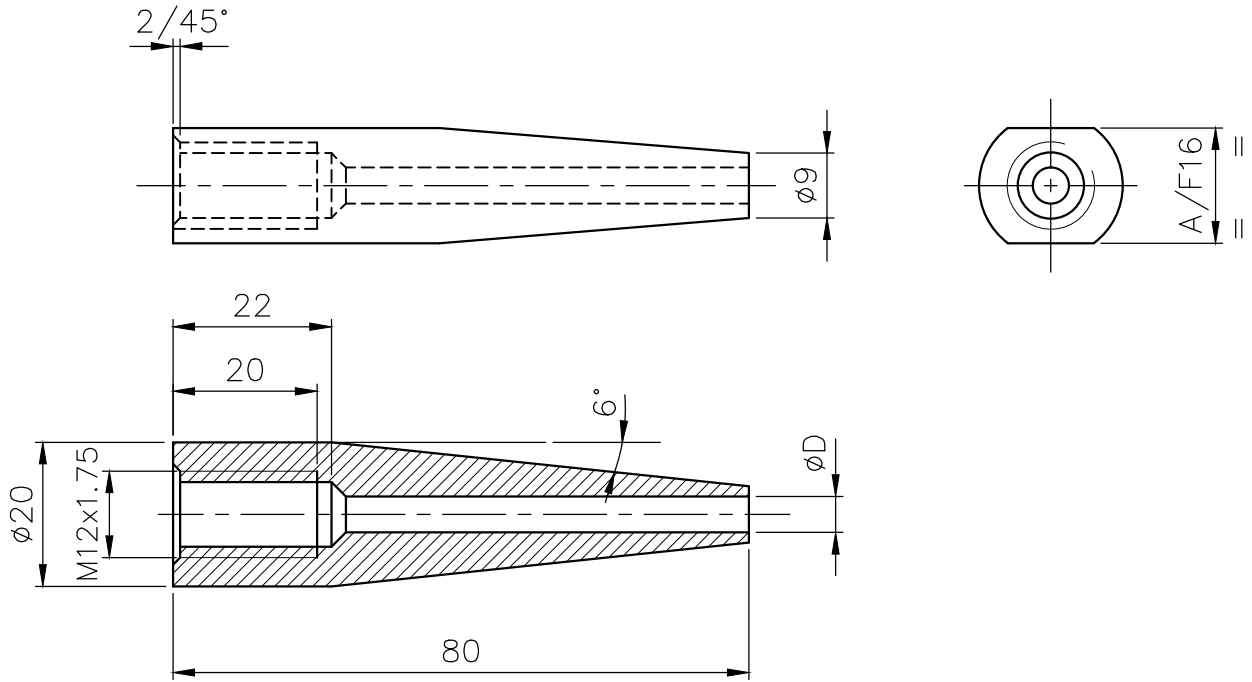

SL.NO.	ØD
01	2.6
02	3.4
03	4.2
04	5.0

①

* ELECTROLYTIC TOUCH PITCH
COPPER AS PER ASTM/C11000
 Cu.-99.95 % Min
 O.-0.04 % Min
 S-0.003 % Max

NOTE: -

01. HOLE ØD, TO BE DONE THROUGHTOUT IN SINGLE DIRECTION AND IN SINGLE SETTING
02. HOLE ØD TO BE ENGRAVED AT THE TOP OF THE CONTACT TIP.
03. SHARP CORNERS TO BE REMOVED.

X		Ø20x80 L	ETP COPPER	ASTM C 11000				
No.of Pieces	DESCRIPTION		MATERIAL	STANDARD	NET.WT.IN KGS.	DRAWING No.		ITEM No.
		REFERENCE:	ALTERATIONS:		DCN REF	DATE	SIGN.	INDEX
SCALE	DRAWN/TC	S.Selvamanickam	HOLEØ2.6 ADDED			07.04.10	CSJ	①
1:1	CHECKED	R.Ramamoorthy	MATERIAL COMP. ADDED			06.01.12'	CSJ	②
	APPROVED	C.S.Jayasheelan						
	DATE	08.07.93/07.04.10'						
MACHINE: SUBMERGED ARC WELDING			TYPE: ESAB					
TITLE:			DRAWING No:			REV.		
			CONTACT TIP Ø20X80 L			4M10A152507002		
			Sheet No:			No.of Sheets:		

CAUTION: THIS DRAWING IS OUR SOLE PROPERTY AND SHOULD NOT BE USED IN ANY FORM FOR ANY PURPOSE WITHOUT THE WRITTEN PERMISSION OF BHARAT HEAVY ELECTRICALS LIMITED TRICHIRAPPALLI - 620 014.

ALL DIMENSIONS ARE IN MM

1.6 ✓

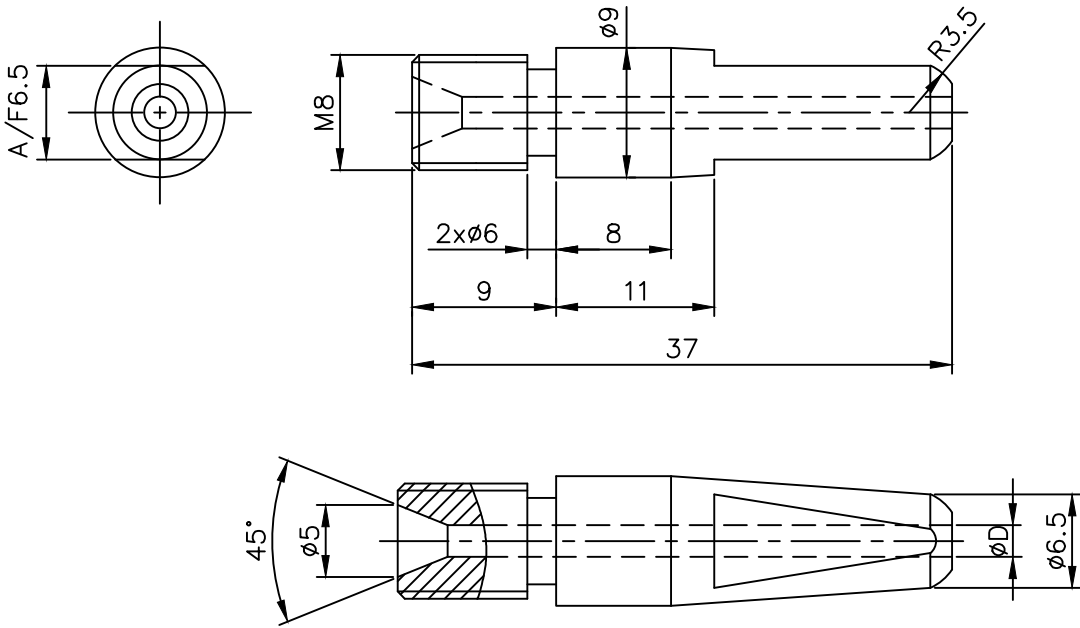

* CHROMIUM ZIRCONIUM COPPER ^②

AS PER USA-UNS Cr.Zr.

Cr. - 0.65% Min
 Zr. - 0.08% Min
 Cu. - 99% Min

①	SL.No.	FOR WIRE ϕ	ϕD	REMARKS
	01	1.2	$\phi 1.25^{+0.05}_{-0.00}$	DRUM PACK
	02	1.2	$\phi 1.3^{+0.05}_{-0.00}$	WIRE SPOOL
	03	1.6	$\phi 1.7^{+0.05}_{-0.00}$	

NOTE:

01. HOLE ϕD , TO BE DONE THROUGH OUT IN SINGLE DIRECTION AND IN SINGLE SETTING.
02. HOLE ϕD TO BE ENGRAVED AT THE TOP OF THE CONTACT TIP.
03. SHARP CORNERS TO BE REMOVED.

X		$\phi 9 \times 37L$		*							
No. of Pieces	DESCRIPTION			MATERIAL	STANDARD	NET.WT.IN KGS.		DRAWING No.		ITEM No.	
		REFERENCE:			ALTERATIONS:		DCN REF	DATE	SIGN.	INDEX	
SCALE 2:1	DRAWN	TTB		MODIFIED TABLE COLUMN				16.05.13	KR	①	
	CHECKED	R.RAMAMOORTHY		MATERIAL COMP. ADDED				18.05.13	KR	②	
	APPROVED	C.S.JAYASHEELAN									
	DATE	02/02/2006									
MACHINE: SUBMERGED ARC WELDING						TYPE: PEMAMEKOY					
TITLE: CONTACT TIP (PSF 505 CO ₂ & 20 TORCH WELDING)						DRAWING No:				REV.	
						4M10A5427700				02	
						Sheet No:				No. of Sheets:	

PR0133256371

Sl. No.	Pre-Qualification Criteria	Bidder Remark
1	<p>Vendor shall give confirmation to BHEL's Technical Specification.</p> <p>Any deviation from the Specification are to be mentioned in the "Bidder remark Space".</p> <p>If There is no deviation vendor should indicate "No Deviation".</p>	

Seal and Sign of Authorized Person

Annexure – A- Additional Terms and Conditions for GeM Enquiry

The terms and condition mentioned in this document are applicable in addition to the GeM General Terms and Conditions. Bidders shall furnish pointwise confirmation/details.

<i>To be filled by bidder</i>		
Description of the Equipment:		
GeM Tender No. & Date		
Name of the firm (Bidder)		:
Address		:
Contact details	<u>Contact person 1</u> Name: Designation: Office Phone: Mobile: e-mail: <u>Contact person 2</u> Name: Designation: Office Phone: Mobile: e-mail:	
Offer/Quotation reference with date		:
SI · N O	Terms and conditions	Vendor's confirmation
1.	Technical: Supply of Contact tips shall be as per technical Specifications attached with the enquiry. Bidder shall comply the technical specification as per the enquiry. Any clarifications/deviations to the specification requirements are to be clearly indicated in the above format. Hidden deviations indicated elsewhere in the offer will not be evaluated.	
2.	Pre-qualification requirement: Offer shall be considered only if bidder is meeting Tender Prequalification requirement (Annexure-B). Vendor to comply with Pre-Qualification requirement of the tender and submit along with their technical bid - the credentials and other documents as indicated in the PQR in the format prescribed. Otherwise their offer will get rejected.	
3.	Inspection by BHEL/as per Technical specification(if any).	
4.	Vendor offers will be considered for price bid opening subject to fulfilment of techno commercial suitability.	
5.	Evaluation of tender will be item wise.	
6.	Payment terms: <ol style="list-style-type: none"> 1. Payment terms for Micro & Small Enterprises (MSEs): Within 45 days after CRAC. To entitle the above payment terms, the supplier should be manufacturer of the offered item and should upload UDYAM Registration Certificate in proof of MSE. 2. Payment terms for Medium Enterprises: Within 60 days after CRAC. To entitle the above payment terms, the supplier should be manufacturer of the offered item and should upload UDYAM 	

	<p>Registration Certificate in proof of Medium Enterprises.</p> <p>3. Payment terms for Non MSME Suppliers: Within 90 days after CRAC</p> <p>4. Dealers/Traders (if the quoted items are not manufactured by the supplier) shall be considered as Non-MSME supplier for this tender.</p> <p>Payment shall be as per above terms. This a mandatory deemed accepted clause if you are submitted your offer through GeM. Any deviation in this clause anywhere in the offer will be ignored. In case of Auto PRC/CRAC, Payment due date shall be calculated from CRAC date or material acceptance date by BHEL whichever is later.</p>	
7.	<p>Firm Price: The quoted / finalised rates shall be Firm till execution of the supplies. Offer with PVC clause will not be considered.</p>	
8.	<p>Liquidated Damages: LD terms shall be as per GeM General Terms and Conditions. Invoice date/Bill of Lading date/Airway Bill date/Lorry way bill date/e-waybill/Railway Receipt date, whichever is later will be considered for LD calculation.</p>	
9.	<p>Delivery term: The quote shall be on FOR BHEL Trichy destination basis inclusive of Packing, forwarding, Freight also to yours account. Transit Insurance is under Supplier scope.</p>	
10.	<p>Performance Bank Guarantee: Not Applicable</p>	
11.	<p>Repair & replacements: Within the guarantee period vendor has to replace / rectify the defective/ damaged items on free of cost within a reasonable time of reporting from our end.</p>	
12.	<p>Kindly Indicate the HSN Code for all items</p>	
13.	<p>Rate quoted in GeM portal should be on FOR destination basis inclusive of all taxes, freight etc. Transit Insurance is under Supplier scope.</p> <p>Please indicate the applicable GST %, P & F and freight cost (in % of material cost), which is included in your quoted rate in GeM portal.</p>	
14.	<p>Documents are to be submitted along with technical bid (Part-1)</p> <ol style="list-style-type: none"> 01. Covering letter 02. Unpriced offer. 03. Filled up and signed technical specification (GeM Tender catalogue). 04. Filled BHEL Terms and condition sheet (Annexure-A). 05. Filled Annexure-B - PQR along with supporting documents. 06. Documents required along with offer as per technical specification 07. Product Catalogues (if any). 08. MSE UDYAM Certificate (if applicable). 09. Self-certification for local content declaration as per Make In India Policy <p>Note: All the pages of documents are to be signed and sealed by authorized signatory of the company. Any query during enquiry stage shall be replied within two days failing which offer may be rejected as</p>	

	non-responsive.	
15.	Inspection and testing requirements: Inspection and testing requirements are to be carried out as per the specification and BHEL Technical specifications in the enquiry. All test certificates are to be submitted while supply. If required by BHEL, test certificates to be produced before supply.	
16.	Response to Tenders for Indigenous supplier will be entertained only if the vendor has a valid GST registration Number (GSTIN) which should be clearly mentioned in the offer. If the dealer is exempted from GST registration, a declaration with due supporting documents need to be furnished for considering the offer. Dealers under composition scheme should declare that he is a composition dealer supported by the screen shot taken from GSTN portal. The dealer has to submit necessary documents if there is any change in status under GST.	
17.	Supplier shall mention their GSTIN in all their invoices (incl. credit Notes, Debit Notes) and invoices shall be in the format as specified/prescribed under GST laws. Invoices shall necessarily contain Invoice number (in case of multiple numbering system is being followed for billing like SAP invoice no, commercial invoice no etc., then the Invoice No. which is linked/uploaded in GSTN network shall be clearly indicated), Billed to party (with GSTIN) & Shipped to party details, item description as per PO, Quantity, Rate, Value, applicable taxes with nomenclature (like IGST, SGST, CGST & UTGST) separately, HSN/ SAC Code, Place of Supply etc. Wherever E-Invoice is applicable, the tax invoice/ CN / DN submitted by the vendor must contain the QR code generated in E-Invoice Portal & IRN.	
18.	All invoices shall bear the HSN Code for each item separately (Harmonized System of Nomenclature)/ SAC code (Services Accounting Code).	
19.	Invoices will be processed only upon completion of statutory requirement and further subject to following: <ul style="list-style-type: none"> • Vendor declaring such invoice in their GSTR-1 Return/ IFF • Receipt of Goods or Services and Tax invoice by BHEL. 	
20.	As the continuous uploading of tax invoices in GSTN portal (in GSTR-1/ IFF) is available for all (i.e. both Small & Large) tax payers, all invoices raised on BHEL may be uploaded immediately in GST portal on dispatch of material /rendering of services. The supplier shall ensure availability of Invoice in GSTN portal before submission of invoice to BHEL. Invoices will be admitted by BHEL only if the invoices are available in GSTN portal (in BHEL's GSTR-2A/ GSTR-2B).	
21.	In case of discrepancy in the data uploaded by the supplier in the GSTN portal or in case of any shortages or rejection in the supply, then BHEL will not be able to avail the tax credit and will notify the supplier of the same. Supplier has to rectify the data discrepancy in the GSTN portal or issue credit note or debit note (details also to be uploaded in GSTN portal) for the shortages or rejections in the supplies or additional claims, within the calendar month informed by BHEL.	
22.	In cases where invoice details have been uploaded by the vendor but failed to remit the GST amount to GST Department (Form PMT-08 or Form GST RET-01 to be submitted) within stipulated time, then GST paid on the invoices pertaining to the month for which GST return not filed by the vendor will be recovered from the vendor along with the applicable interest (currently 24% p.a) and all subsequent bills of the vendor will not be processed till filing of the GST return by the vendor	

23.	In case GST credit is denied to BHEL due to non-receipt or delayed receipt of goods and/ or tax invoice or expiry of timeline prescribed in GST law for availing such ITC, or any other reasons not attributable to BHEL, GST amount claimed in the invoice shall be disallowed to the vendor.	
24.	Where any GST liability arising on BHEL under Reverse Charge (RCM), the vendor has to submit the invoices to BHEL well within the timeline prescribed in GST Law, to enable BHEL to discharge the GST liability. If there is a delay in submission of invoice by the vendor resulting in delayed payment of GST by BHEL along with Interest, then such Interest payable or paid shall be recovered from the vendor.	
25.	GST TDS will be deducted as per Section 51 of CGST Act 2017 and in line with Notification 50/2018 –Central Tax dated 13.09.2018. GST TDS certificate will be generated in GSTN portal subsequent to vendor accepting the TDS deduction in the GSTN portal & the vendor can directly download the Certificate from the GSTN Portal.	
26.	<p>As per the provisions of Section 194Q of the Income Tax Act, we BHARAT HEAVY ELECTRICALS LIMITED, HPBP, TRICHY having PAN AAACB4146P, had turnover in the preceding financial year for more than Rs 10 Crores.</p> <p>Hence, we are liable as buyer to deduct tax at source on the payment for invoices issued by Supplier on or after 1st July 2021. Accordingly, discontinue charging TCS u/s 206C(1H) on invoices issued from 1st Jul 2021 onward.</p> <p>We shall deduct the eligible TDS u/s 194Q on the payments for invoices issued on or after 1st Jul 2021. TDS deducted so, shall be deposited to the Income Tax Department, and TDS certificate to this effect. Tax credit of such TDS shall reflect in FORM26AS of the supplier at the end of same quarter in which TDS is deducted.</p> <p>For Suppliers who have not filed Income Tax returns for the last 2 preceding assessment years, TDS deduction at higher rates will be applicable as per Section 206AB and Section 206CCA of Income-tax act.</p>	
27.	GST CREDIT: Suppliers are advised to get registered to GSTN portal. Tenderer under "GST credit" shall be preferred.	
28.	<p>BILL PROCESSING METHOD:</p> <p>Supplier has to ensure the full quantity of material delivery within given PO delivery date to process the bill for payment. In case supplier fails to deliver full quantity within delivery date, bills received after PO delivery date will be processed after final despatch of the total pending supply. Further, bills will be clubbed and forwarded for payment processing as a single bunch.</p>	
29.	<p>MSE /START-UP VENDOR:</p> <p><i>UDYAM Registration certificate shall be submitted by MSE vendors to avail MSE benefits. Start-up category certificate shall be submitted by start-up companies to avail exemption in Annual Turnover/Past experience if PQC stipulates requirement of Annual Turnover/Past experience.</i></p>	
30.	<p>Make in India Policy:</p> <p>Refer the Tender document regarding public procurement policy (Preference to Make in India), Order 2017.</p> <p>"Bidders shall ensure to apply for Make In India preference while quoting through GeM portal. Otherwise offer will not be considered.</p>	

	The local supplier at the time of tender, bidding or solicitation shall be required to provide self-certification that the item offered meets the minimum local content and shall give details of the Location(s) at which the local value addition is made."	
31.	Fraud Prevention Policy Bidder along with its associate /collaborators /sub-contractors /sub-vendors / consultants / service providers shall strictly adhere to BHEL Fraud Prevention Policy displayed on BHEL website http://www.bhel.com and shall immediately bring to the notice of BHEL Management about any fraud or suspected fraud as soon as it comes to their notice.	
32.	Risk purchase clause: a. In the event of any successful Tenderer's failure to fulfil any of the tender / Contract obligations including supply of whole or any part of the ordered items as per Contract / Agreement, BHEL has the right to terminate the contract and purchase from elsewhere, at the risk and cost of the defaulted supplier, either the whole of the goods or any part which the supplier has failed to deliver or dispatch within the time stipulated in the contract or if the same were not available, the best and nearest available substitute thereof. The supplier shall be liable for the additional expenditure/difference in Cost, if any, including consequential losses which BHEL may sustain by reason of risk purchase in addition to the applicable LD as per the Purchase order/contract. b) The decision of BHEL with regard to the additional expenditure / difference in cost and consequential losses incurred by BHEL shall be final and binding on the supplier. c) The amount recoverable under risk purchase shall be recovered from the defaulted supplier in all or any of the following manners: i. from dues available in the form of Bills payable to defaulted supplier, SD, BGs against the same contract. ii. from the dues payable to defaulted supplier against other contracts in the same Region/Unit /any other region/unit iii. In-case recoveries are not possible with any of the above available options, Legal action shall be initiated for recovery against defaulted supplier. iv. GST will be applicable to the amount recoverable under risk purchase.	
33.	Set off : BHEL shall have the right to recover any money which in the sole opinion of BHEL is due from the supplier from any money due to the supplier under this Contract or any other contract or from the Security Deposit/BG furnished by the supplier under this Contract or any other contract.	
34.	Cartel Formation: The Bidder declares that they will not enter into any illegal or undisclosed agreement or understanding, whether formal or informal with other Bidder(s). This applies in particular to prices, specifications, certifications, subsidiary contracts, submission or non-submission of bids or any other actions to restrict competitiveness or to introduce cartelization in the bidding process. In case, the Bidder is found having indulged in above activities, suitable action shall be taken by BHEL as per extant policies/ guidelines.	
35.	The following documents are to be sent along with consignment to store: One Duplicate for Transporter copy of tax invoice + one extra copy of tax invoice + Delivery challan + LR COPY+E-Way bill+ Test Certificates (if applicable).	

36.	Seller Tax invoice, LR copy, E-Way bill, Courier docket etc. are to be uploaded in GeM portal while updating dispatch details in GeM portal	
37.	Seller Tax invoices (Original for Recipient + Duplicate for Transporter) either in Original hard copies or Digitally Signed Soft copies along with copy of LR + E-Way bill are to be sent to the buyer	
<p>Note:</p> <ol style="list-style-type: none"> 1. In the event of our customer order covering this tender being cancelled /placed on hold / otherwise modified, BHEL would be constrained to accordingly cancel / hold / modify the tender at any stage of execution. 2. BHEL may negotiate the L1 rate, if not meeting our budget / estimated cost. BHEL may re-float the tender opened, if L1 price is not acceptable to BHEL. 3. BHEL reserves its right to reject an offer due to unsatisfactory past performance by the respective Vendor in the execution of any contract to any BHEL project / Unit. 4. Any other commercial terms indicated by the vendor in their offer elsewhere will be ignored. BHEL will proceed with tender evaluation as per Annexure-A and GeM general terms and conditions only. 		