

### Annexure-A

Standard Guidelines for Worker's Accommodation / Establishments at BHEL-Project Sites.

#### 1). The following key parameters should be followed during construction of workers accommodation/establishments at project sites: -

- a) Land for labour colony shall be arranged by Contractor at their own cost as per availability outside project area preferably within 5Km. Necessary levelling/dressing of land shall be done by the contractor. All arrangement for electricity and drinking/service water to be arranged by the contractor within his quoted price. However, BHEL may provide land on sharing basis for worker establishment in case Owner provides the same to BHEL.
- b) Water & Electricity for worker establishments shall be suitably arranged by the agency with proper electrical wiring and fitting.
- c) Providing and maintaining facilities for safety, welfare, drinking water and sanitation, hygiene, biennial health check-up etc. for construction workers at their workplaces as well as at labour & staff colonies by the agencies.
- d) The workers accommodation barracks/hutment should be placed as per approved layout plan of BHEL. Agencies to construct temporary labour colony/ hutment, toilets as per attached drawings, after obtaining approval from BHEL site.
- e) **General layout plan for accommodating 120 workers with toilet facilities have been provided in the drawing.** In case, agencies are required to deploy more/less number of workmen at site, the size/nos of shed may be increased/decreased accordingly in consultation with BHEL site. The worker's shed position & its size shall be reviewed & approved by BHEL considering maximum number of workers planned for deployment. No construction shall be permitted without prior approval of proposed layout of worker accommodation by BHEL.
- f) The type and nature of construction for worker accommodation sheds should be preferably uniform for all the agencies so as to bring out a pleasant aesthetic view of the worker's establishment.
- g) For women workers deployed at site, exclusive separate facilities (sheds, bathrooms, etc) considering the privacy & safety of women should be provided by the agency.
- h) The clear ceiling height of the barracks should be minimum 3 metres. There should be minimum 3ft spacing between two beds to ensure adequate privacy & hygiene of the place. The type of sleeping bed in each barrack should be wooden/metal type & no substandard quality sleeping bed will be allowed by BHEL. Wardrobe/shelves for storage of clothes & other essentials to be provided in each hall.
- i) The size of barracks / hutments should be decided considering minimum space requirement of 3.6 sqm / per workers & there should be minimum 3 m spacing between two barrack side by side & 15 m. front to front as shown below. A typical layout plan of labour colony is shown in **Annexure-IA**.

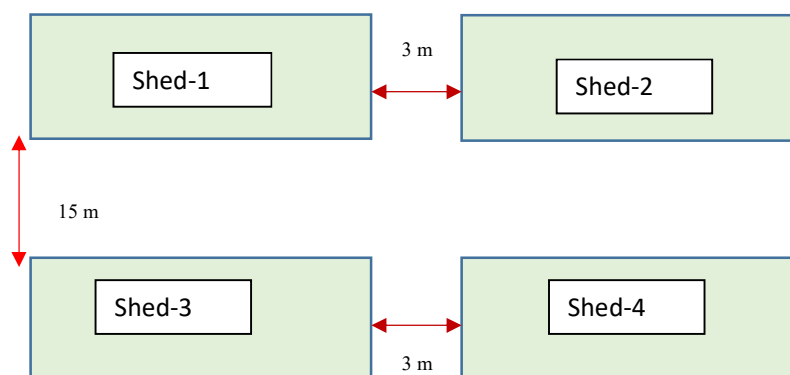

## Annexure-A

### Standard Guidelines for Worker's Accommodation / Establishments at BHEL-Project Sites.

#### **2). Facilities to be Provided at Labour Establishment**

**a) Toilet, Bathing & Washing: -**

- i). Sufficient numbers of toilets, urinals and bathing room within each barrack/shed with complete water supply system. Minimum 1 nos. urinal cum toilet for every 10 persons and 1 no. bathing room for every 10 persons should be ensured. There should not be any open bathing place in the labour colony to maintain proper hygiene.
- ii). Septic tank/Bio-digester with proper inlet/outlet connection to be provided for each shed
- iii). Suitable / proper arrangements for washing clothes & drying washed clothes shall be made.

**b) Service & Drinking Water: -**

- i). Proper storage facilities for both service water & drinking water in the labour colony. In case ground water is the source for both service & drinking purpose, water purification plant should be installed for both service & drinking water purpose. The cost of water purification plant has to be borne by the agencies on sharing basis.

**c) Medical Facilities: -**

- i). One Medical centre (24 x7 working), well finished & furnished, of approx. 150sqm shall be constructed by the contractor in the labour establishment area for the workmen.
  - Doctor's room with attached toilet (approx. 12x12 sqft),
  - Nurses Room with attached toilet (approx 12x12 sqft),
  - Dispensary area (approx. 10x10 sqft)
  - Balance area shall be procedure room/hall.
- ii). Deployment of 2 nos MBBS Doctors and 4 nos trained Male/Female nurses for round the clock service with running medicines.
- iii). Dedicated ambulance in the labour colony for 24x7 hrs emergency medical situation fully equipped with ventilation facilities.
- iv). Cost of medical establishment including payments for medical staffs such as doctors, nurse, ambulance services, consumables, medical instruments/devices & running medicines cost has to be borne by the availing agencies on sharing basis as decided by BHEL site.

**d) Safety, Cleaning & Hygiene: -**

- i). The regular cleaning and housekeeping of labour establishments, storage water tank, open areas should be ensured by the agencies to maintain proper hygiene. Dedicated persons to be deployed for cleaning of toilets on daily basis.
- ii). Proper ventilation and lighting in both day & night. Proper false ceiling (in extreme hot conditions) & ceiling fans/coolers shall be provided in the barracks.
- iii). Readily accessible adequate first aid boxes, minimum 4 numbers each of fire extinguishers & dust bins shall be provided in each barrack/shed.
- iv). Centralised garbage dumping storage area in the labour colony & its regular clearance should be ensured by the agencies.
- v). Suitable arrangement for regular Pest / ants / Rodent / Rats / Snakes / Mosquito control in the labour colony shall be made with a reputed firm/ organisation by the vendor at their cost. Window mesh for prevention from mosquito shall be ensured.
- vi). Proper surface water drainage system to be followed by the agencies as per BHEL approved layout plan of the labour colony. No water logging should take place in and around labour colony even during peak rainy season.

## **Annexure-A**

### **Standard Guidelines for Worker's Accommodation / Establishments at BHEL-Project Sites.**

vii). Proper security deployment 24x7 for labour establishment by the respective agency

**e) General Points: -**

- i). Proper approach road to the labour colony & its connectivity with each barrack with necessary hard surfacing preferably with brick flat soling/paver blocks/PCC paving.
- ii). Separate kitchen facilities with dining hall & clean cooking fuel (without smoke) should be used uniformly in labour establishments to avoid health hazards.
- iii). Space for recreation facilities of the workers like playground etc. The maintenance of the recreation facilities should be ensured by the agencies on sharing basis. Also, weekly or fortnightly games/get-together/entertainment to be organised by the vendor for building motivation & team spirit amongst the labour.
- iv). Proper transportation arrangement / conveyance for going to work place from labour colony would have to be ensured by agency. No two-wheelers would be permitted inside plant premises.

### **3). Compliances of Guidelines: -**

The contractor shall maintain the labour colony for its workmen as per BHEL guidelines. 0.25 % of every RA Bill shall be linked on certification from BHEL for compliance with the guidelines of labour colony.

In case labour establishment is not completed as per the layout drawing and compliance with statutory norms/BHEL Guidelines and any penalty is imposed by Customer, same shall be recovered from contractor's RA Bill.

Regular visit of workmen establishment shall be done by team from BHEL to ensure implementation of above guidelines. Any irregularities observed shall have to be rectified by agencies on immediate basis.

In case, the report submitted by BHEL team is not satisfactory, necessary actions including recoveries (0.25% of RA Bill value) shall be done as per contract. In addition to the recoveries as per contract (0.25% of RA Bill value), expenses incurred (if any) for maintenance & rectification by BHEL shall be recovered from agency along with 5% overheads.

In case Owner/Customer specific guidelines & drawings w.r.t worker's establishment are available in any project, the same shall prevail over and above the BHEL guidelines. Also, in case of conflict of guidelines stipulated in BHEL HSE documents, the more stringent guidelines shall prevail.

Any other welfare measures which the Central Government considers, under the set of circumstances, as required for decent life of workers shall be ensured as per following applicable Labour Laws: -

- Contract Labour (Regulation & Operative) Act, 1970,
- Inter-State Migrant Workmen (Regulation of Employment and Condition of Services) Act, 1979,
- The Building and Other Construction Workers Act, 1996.
- Labour Code on Occupational Safety, Health and Working Conditions issued by Government of India

**Central Procurement Cell (CPC), BHEL-PSHQ**

**Annexure-IA: General Layout Arrangement of Worker's Establishment for BHEL-Project site**

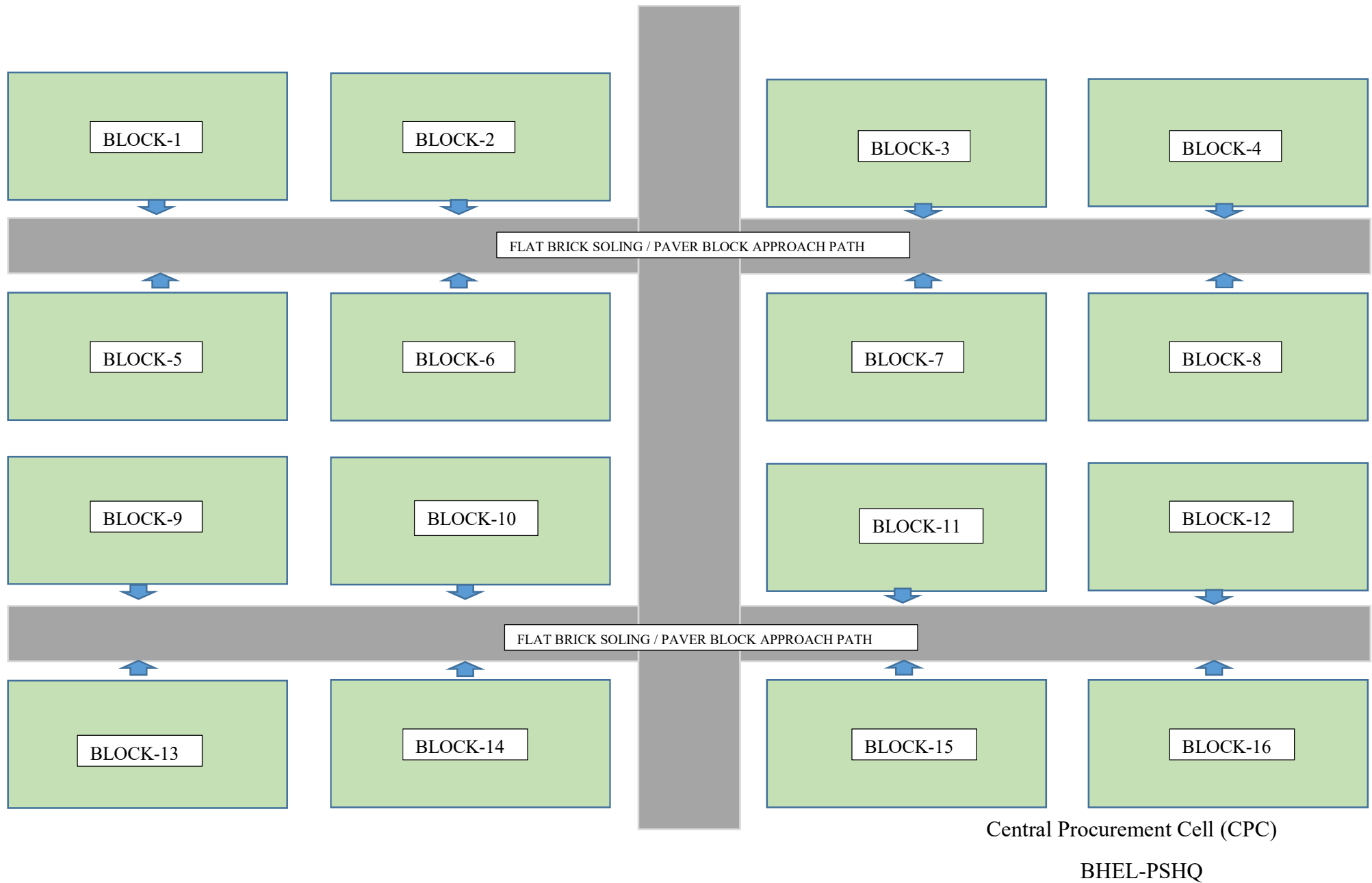

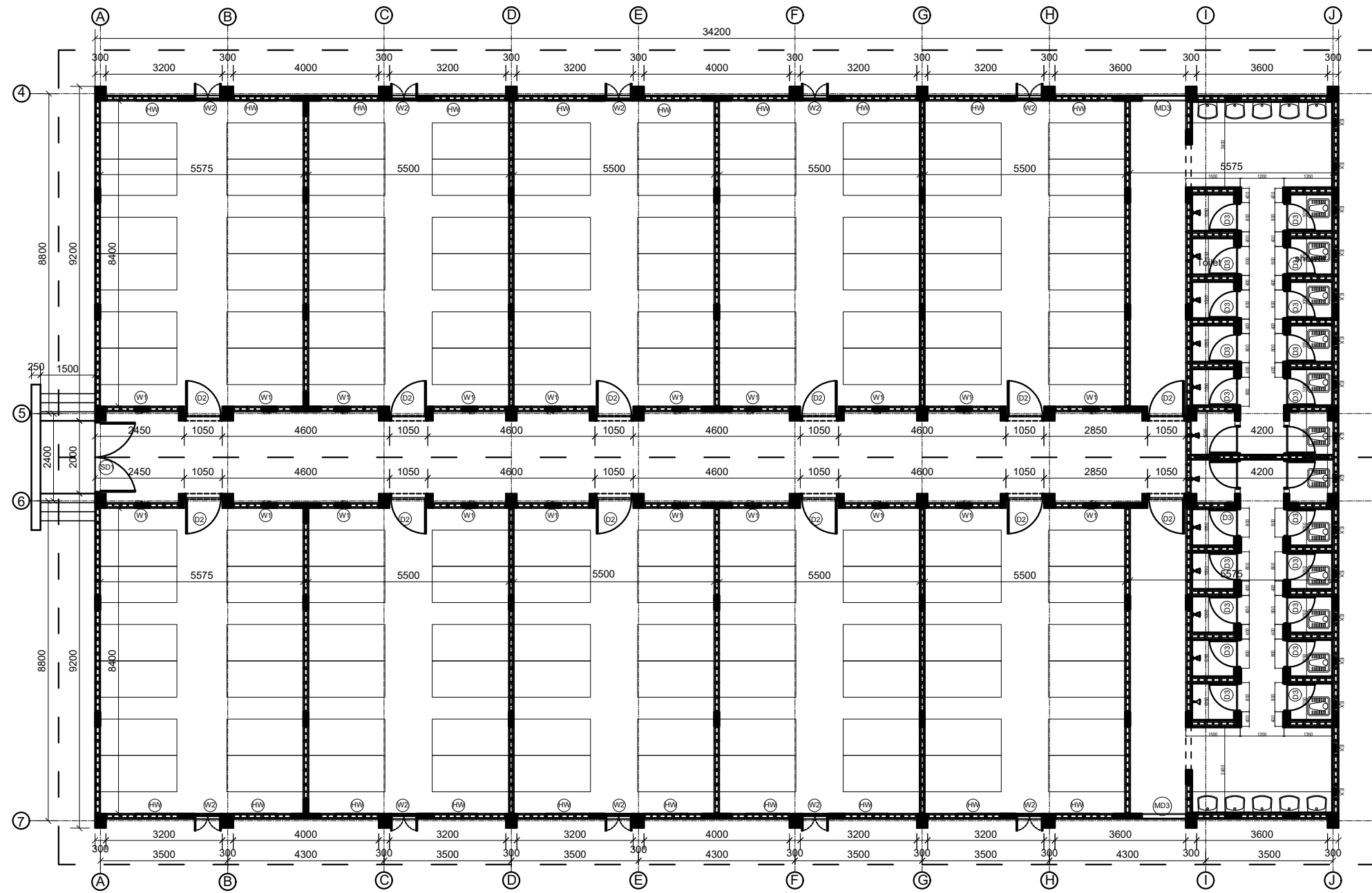

TYPICAL LAYOUT FOR WORKMEN'S SHED (120 nos.)

NOTES:-

1. ALL DIMENSIONS ARE IN MILLIMETRE AND ELEVATIONS ARE IN METRE U.N.O.
2. DRAWING SHALL BE READ IN CONJUNCTION WITH THE TERM & CONDITIONS, AS SPECIFIED IN ANNEXURE A-STANDARD GUIDELINES.
3. GENERAL LAYOUT PLAN FOR ACCOMMODATING 120 WORKERS WITH TOILET FACILITIES HAVE BEEN PROVIDED IN THE DRAWING. IN CASE, AGENCIES ARE REQUIRED TO DEPLOY MORE/LESS NUMBER OF WORKMEN AT SITE, THE SIZE/NO. OF SHED MAY BE INCREASED/DECREASED ACCORDINGLY IN CONSULTATION WITH BHEL SITE.
4. THE TYPE AND NATURE OF CONSTRUCTION FOR WORKER ACCOMMODATION SHEDS SHOULD BE PREFERABLY UNIFORM FOR ALL THE AGENCIES SO AS TO BRING OUT A PLEASANT AESTHETIC VIEW OF THE WORKER'S ESTABLISHMENT.
5. FOR WOMEN WORKERS DEPLOYED AT SITE, EXCLUSIVE SEPARATE FACILITIES (SHEDS, BATHROOMS, ETC) CONSIDERING THE PRIVACY & SAFETY OF WOMEN SHOULD BE PROVIDED BY THE AGENCY.
6. THE CLEAR CEILING HEIGHT OF THE BARRACKS SHOULD BE MINIMUM 3 METRES.
7. DOORS & WINDOWS SHALL BE OF WOOD/METAL MAKE.
8. LAND FOR LABOUR COLONY SHALL BE ARRANGED BY CONTRACTOR AT THEIR OWN COST AS PER AVAILABILITY OUTSIDE PROJECT AREA PREFERABLY WITHIN 5KM. NECESSARY LEVELLING/DRESSING OF LAND SHALL BE DONE BY THE CONTRACTOR.
9. WATER & ELECTRICITY FOR WORKER ESTABLISHMENTS SHALL BE SUITABLY ARRANGED BY THE AGENCY WITH PROPER ELECTRICAL WIRING AND FITTING.
10. SUFFICIENT NUMBERS OF TOILETS, URINALS AND BATHING ROOM WITHIN EACH BARRACK/SHED WITH COMPLETE WATER SUPPLY SYSTEM. MINIMUM 1 NOS. URINAL CUM TOILET FOR EVERY 10 PERSONS AND 1 NO. BATHING ROOM FOR EVERY 10 PERSONS SHOULD BE ENSURED.
11. SEPTIC TANK/BIO-DIGESTER WITH PROPER INLET/OUTLET CONNECTION TO BE PROVIDED FOR EACH SHED.
12. PROPER APPROACH ROAD TO THE LABOUR COLONY & ITS CONNECTIVITY WITH EACH BARRACK WITH NECESSARY HARD SURFACING PREFERABLY WITH BRICK FLAT SOLING/PAVER BLOCKS/PCC PAVING.

**BHARAT HEAVY ELECTRICALS LTD**  
 POWER SECTOR  
 CENTRAL PROCUREMENT CELL (CPC)  
 PSHQ

TITLE

TYPICAL LAYOUT FOR WORKMEN'S SHED (120 nos.)

COPY RIGHT AND CONFIDENTIAL  
 The information on this document is the property of BHARAT HEAVY ELECTRICALS LIMITED  
 It must not be used, copied or otherwise disseminated to any third party without the written consent of the company.