



VOLUME – IA  
Part I & II

TECHNICAL  
CONDITIONS OF  
CONTRACT  
(TCC)

BHARAT HEAVY ELECTRICALS LIMITED



# TECHNICAL CONDITIONS OF CONTRACT (TCC)

---

## CONTENTS

S.No.	DESCRIPTION	Chapter	No. of Pages
<b>Vol I A</b>	<b>Part-I: Contract specific details</b>		
1	Project Information	Chapter-I	01
2	Scope of works	Chapter-II	01
3	Facilities in Scope of Contractor / BHEL (Scope Matrix)	Chapter-III	05
4	T&Ps and MMEs to be deployed by Contractor	Chapter-IV	01
5	T&Ps and MMEs to be deployed by BHEL on sharing basis	Chapter-V	01
6	Time Schedule	Chapter-VI	02
7	Terms of Payment	Chapter-VII	01
8	Taxes and other Duties	Chapter-VIII	02
9	Bill of Quantity	Chapter-IX	01
10	General	Chapter-X	10
<b>Vol IA</b>	<b>Part-II: Technical specifications</b>		
1	Corrections / Revisions in Special Conditions of Contract, General Conditions of Contract and Forms & Procedures	Chapter-1	03
2	Standard Specification for Topographical Survey	Chapter-2	11
3	Drawings (Tender Purpose Only)	Chapter-3	01
4	Specific HSE Plan for Sub Contractors for Damanjodi project	Chapter-4	82
5	Form 14 Rev 01	Chapter-5	06
6	Proforma Of Bank Guarantee (In Lieu Of Security Deposit)- Form WAM 22	Chapter-6	03
7	Procedure For Conduct Of Conciliation Proceedings	Chapter-7	11

**VOLUME - IA PART – I CHAPTER – I**  
**PROJECT INFORMATION**

1.	Name of the Project	Wet Limestone based Flue Gas Desulphurisation System in 1 X 600 MW MTPS-II.
2.	Owner	TANGEDCO Limited, Mettur Thermal Power Station-II (MTPS-II), Mettur Dam - 636406, Tamil Nadu, India
3.	Consultant	MECON LIMITED, Ranchi
4.	Site Location	Around 363 km south-west of Chennai and in Salem District, Tamil Nadu.
5.	Latitude	11° 56' N
6.	Longitude	77° 48' E
7.	Elevation above MSL	+ 212 M to + 253 M above MSL
8.	Nearest Railway Station	Mettur Dam
9.	Nearest Airport	Salem, at a distance of 55 km
10.	Road Access/Approach to Site	Thoppur, Bhavani Road National Highway 544 H
11.	Site Conditions	
i.	Max. Relative Humidity	90 %
ii.	Min. Relative Humidity	40 %
iii.	Annual Average Rainfall	200 mm
iv.	Wind direction	Predominantly in west direction
v.	Wind Speed	15 km/hr (average)
vi.	Seismicity	Zone II, (As per IS : 1893)

**VOLUME-IA PART-I CHAPTER – II**  
**SCOPE OF WORKS**

**The scope of work shall comprise but not limited to the following:**

**(All the works mentioned hereunder shall be carried out within the accepted rate unless otherwise specified.)**

- 1.2.1 Broadly, scope of works covers topographical survey of area of FGD. It is not intent herein to specify all details. Any item related to this work, not covered here under but necessary to complete the system will be deemed to have been included in the scope of work.
- 1.2.2 For detailed scope of Topographical survey work refer enclosed bill of quantity (in price bid), standard specification and layout.
- 1.2.3 Note:  
The bidder should visit site and acquire full knowledge & information about site conditions and acquaint themselves with the conditions prevailing at site and in & around the plant premises, together with all statutory, obligatory, mandatory requirements of various authorities before submission of bid.  
FOR FURTHER DETAILED SCOPE OF WORKS REFER RELEVANT CHAPTERS IN THIS BOOK – TECHNICAL SPECIFICATION.

# TECHNICAL CONDITIONS OF CONTRACT (TCC)

## VOLUME IA PART – I CHAPTER – III

### Facilities & Consumables in the scope of Contractor / BHEL

#### (Scope Matrix)

Sl.No	Description	Scope to be taken care by		Remarks
		BHEL	Bidder	
<b>1.3.1.1.0</b>	<b>PART I ESTABLISHMENT</b>			
1.3.1.1.1	FOR CONSTRUCTION PURPOSE:			
A	Open space for office		Yes	
B	Open space for storage		Yes	
C	Construction of bidder's office, canteen and storage building, cement storage shed including supply of materials and other services		Yes	At bidder's own cost
D	Bidder's all office equipment's, office / store / canteen consumables		Yes	At bidder's own cost
E	Canteen facilities for the bidder's staff, supervisors and engineers etc.		Yes	At bidder's own cost
F	Firefighting equipment's like buckets, extinguishers etc.		Yes	At bidder's own cost
G	Fencing of storage area, office, canteen etc. of the bidder		Yes	At bidder's own cost
1.3.1.1.2	FOR LIVING PURPOSES OF THE SUCCESSFUL BIDDER'S PERSONNEL			
A	Open space		Yes	
B	Living accommodation		Yes	At bidder's own cost
<b>1.3.1.2.0</b>	<b>ELECTRICITY</b>			
1.3.1.2.1	Electricity For construction purposes		Yes	

## TECHNICAL CONDITIONS OF CONTRACT (TCC)

Sl.No	Description	Scope to be taken care by		Remarks
		BHEL	Bidder	
	<b>PART I</b>			
1.3.1.2.1.1	Single point source		Yes	
1.3.1.2.1.2	Further distribution for the work to be done which include supply of materials and execution		Yes	At bidder's own cost
1.3.1.2.2	Electricity for the office, stores, canteen, labour colony, etc of the bidder which include:		Yes	At bidder's own cost
1.3.1.2.2.1	Distribution from single point including supply of materials and service		Yes	At bidder's own cost
1.3.1.2.2.2	Supply, installation and connection of material of energy meter including operation and maintenance		Yes	At bidder's own cost
1.3.1.2.2.3	Duties and deposits including statutory clearances for the above		Yes	At bidder's own cost
1.3.1.2.2.4	Demobilization of the facilities after completion of works		Yes	At bidder's own cost
1.3.1.2.3	Electricity for living accommodation of the bidder's staff, engineers, supervisors etc on the above lines. (in case BHEL provides this facility, the scope should be given without ambiguity)		Yes	
<b>1.3.1.3.0</b>	<b>WATER SUPPLY</b>			
1.3.1.3.1	For construction purposes:		Yes	At bidder's own cost
1.3.1.3.1.1	Making the water available at single point		Yes	
1.3.1.3.1.2	Further distribution as per the requirement of work including supply of materials and execution		Yes	At bidder's own cost
1.3.1.3.2	Water supply for bidder's office, stores, canteen, labour colony, etc.		Yes	

## TECHNICAL CONDITIONS OF CONTRACT (TCC)

SI.No	Description	Scope to be taken care by		Remarks
		BHEL	Bidder	
	<b>PART I</b>			
1.3.1.3.2.1	Making the water available at single point		Yes	At bidder's own cost
1.3.1.3.2.2	Further distribution as per the requirement of work including supply of materials and execution		Yes	At bidder's own cost
<b>1.3.1.4.0</b>	<b>LIGHTING</b>			
1.3.1.4.1	For construction work (supply of all the necessary materials) At office storage area At the preassembly area At the construction site / area		Yes	At bidder's own cost
1.3.1.4.2	For construction work (Execution of the lighting work / arrangements) At office storage area At the preassembly area At the construction site /area At the labour hutment		Yes	At bidder's own cost
<b>1.3.1.5.0</b>	<b>COMMUNICATION FACILITIES for site operations of the bidder</b>	-		
1.3.1.5.1	Telephone, Fax, internet, intranet, email etc		Yes	At bidder's own cost

SI.No	Description	Scope to be taken care by		Remarks
		BHEL	Bidder	
	<b>PART II</b>			
	<b>CONSTRUCTION FACILITIES</b>			
<b>1.3.2.1.0</b>	<b>Engineering works for construction</b>			

## TECHNICAL CONDITIONS OF CONTRACT (TCC)

SI.No	Description	Scope to be taken care by		Remarks
		BHEL	Bidder	
	<b>PART II</b>			
1.3.2.1.1	Providing the construction drawings for all the equipment covered under this scope	Yes		Progressively
1.3.2.1.2	Detailing of drawings for construction		Yes	In consultation with BHEL
1.3.2.1.3	As-built drawings – wherever deviations observed and executed and also based on the decisions taken at site- example – routing of small bore pipes	Yes	Yes	”
1.3.2.1.4	Shipping lists etc for reference and planning the activities	Yes	Yes	”
1.3.2.1.5	Preparation of site construction schedules and other input requirements		Yes	In consultation with BHEL, As per requirement of BHEL targets
1.3.2.1.6	Review of performance (Form-14) and revision of site construction schedules in order to achieve the end dates and other commitments		Yes	
1.3.2.1.7	Weekly construction schedules based on SI No 1.3.2.1.5		Yes	
1.3.2.1.8	Daily construction / work plan based on SI No 1.3. 2.1.7		Yes	For daily monitoring meeting at site
1.3.2.1.9	Periodic visit of the senior official of the bidder to site to review the progress so that works are completed as per schedule. It is suggested this review by the senior official of the bidder should be done once in every two months.		Yes	At bidder's own cost

### 1.3.3 ELECTRICITY

Contractor shall make his own arrangement for electricity and further distribution arrangement that may be required for survey works and as well for his living purposes.

## TECHNICAL CONDITIONS OF CONTRACT (TCC)

---

### 1.3.4 **WATER**

Contractor shall make his own arrangement for water and further distribution arrangement that may be required for survey works and as well for his living purposes.

### 1.3.5 **MATERIAL SUPPLY**

All materials required for the work are in the scope of the contractor.

### 1.3.6 **CONSUMABLE**

All consumables required for the scope of work, shall be arranged by the contractor at his own cost unless otherwise specifically mentioned in the contract. Prior approval from Engineer In-Charge shall be obtained for all the consumable to be used in permanent work.

In the event of failure of contractor to bring necessary and sufficient consumables, BHEL may arrange for the same at the risk and cost of the contractor. The entire cost towards this along-with overhead shall be paid by the contractor or deducted from the contractor's bills.

### 1.3.7 **LIGHTING FACILITY**

Adequate lighting facilities such as flood lamps, hand lamps and area lighting shall be arranged by the contractor at the site of construction, and contractor's material storage area etc. at his own cost.

### 1.3.8 **CONTRACTOR'S OBLIGATION ON COMPLETION**

On completion of work, all the temporary structures etc. shall be dismantled and leveled and debris shall be removed as per instructions of BHEL by the contractor at his own cost, wherever applicable for his scope of work. In the event of his failure to do so, the expenditure towards clearance of the same will be recovered from the contractor. The decision of BHEL Engineer in this regard is final.

### 1.3.9 **BID DRAWINGS**

Tentative layout drawing for information is enclosed and this may get revised during execution.

**VOLUME-IA PART-I CHAPTER – IV**  
**T &Ps AND MMEs TO BE DEPLOYED BY CONTRACTOR**

- 1.4.1 All the tools & plants and MMEs like total station, survey equipments etc required for completion of the scope of works are to be arranged by the contractor within the quoted rate. Any other tools & plants required for this scope of work are to be arranged by the contractor within the quoted rate.
- 1.4.2 All the distribution boards, connecting cables, hoses, etc and temporary connection work including electrical connections shall have to be arranged by the contractor at his own cost.
- 1.4.3 Contractor shall finalize type and number of such T&Ps required for completion of entire scope of work within the stipulated time, within one week of placement of LOI after discussion with engineer in-charge. Accordingly, all the equipment shall be mobilized at site.

**VOLUME-IA PART-I CHAPTER – V**  
**T &Ps AND MMEs PROVIDED BY BHEL**

- 1.5.1 BHEL shall not provide any T & Ps.
- 1.5.2 BHEL shall not provide any MMEs.

**VOLUME-IA PART-I CHAPTER – VI**  
**TIME SCHEDULE**

**1.6.1. TIME SCHEDULE**

- 1.6.1.1. The entire work as detailed in the Tender Specification shall be completed within 20 **(Twenty) Days** from the date of commencement of work at site.
- 1.6.1.2. The date of commencement of work at site shall be mutually agreed between contractor and BHEL engineer-in-charge.
- 1.6.1.3. During the total period of contract, the contractor has to carry out the activities in a phased manner as required by BHEL.
- 1.6.1.4. The work shall be deemed as completed in all respect only when so certified by the site engineer. The decision of BHEL in this regard shall be final and binding on contractor.

**1.6.2. COMMENCEMENT OF CONTRACT PERIOD**

The date of commencement of contract period shall be the mutually agreed date between the contractor and BHEL engineer to start the work. In case of discrepancy, the decision of BHEL engineer is final.

**1.6.3. MOBILISATION**

The activities shall be started as per directions of BHEL. The contractor has to augment his resources in such a manner that following activities are achieved on specified schedule:

<b>Sl.No</b>	<b>Area</b>	<b>Time of completion from the date of commencement of civil work</b>
1.	Commencement of work	As mutually agreed in the site between contractor and BHEL engineer

## TECHNICAL CONDITIONS OF CONTRACT (TCC)

---

Sl.No	Area	Time of completion from the date of commencement of civil work
2.	“DRAFT REPORT” shall be submitted including all field data and the supporting calculations for the conclusions/ recommendation drawn, etc. to BHEL-PEM, New Delhi with copy to BHEL-PSSR, Chennai	10 days from the date of commencement of work
3.	On approval of draft report from BHEL/ PEM, the submission of “FINAL REPORT” to BHEL PEM for approval.	15 days from the date of commencement of work
4.	Final Bill Submission	20 days from the date of commencement of work

1.6.4. The above time allowed for completion of work including Sunday and holidays is from the date of commencement of work. Detailed programme to be prepared by the contractor taking into consideration of the completion schedule.

1.6.5. In order to meet above schedule in general and project schedule requirements, contractor shall arrange & augment all necessary resources from time to time on the instructions of BHEL engineer.

**1.6.6. CONTRACT PERIOD**

The contract period for completion of entire work under this scope shall be **20 (Twenty) Days** from the “COMMENCEMENT OF CONTRACT PERIOD” as specified earlier for completion of the entire work.

**1.6.7. GUARANTEE PERIOD**

Guarantee period is not applicable for this tender.

**VOLUME-IA PART-I CHAPTER – VII**  
**TERMS OF PAYMENT**

1.7.1 **Secured Advance** - Not applicable

1.7.2 **Advance for Mobilization** - Not applicable

1.7.3 **Terms of payment**

The progressive payment against monthly running bills for the completed items will be released on accepted rate/ price of contract value as mentioned below from clause no. 1.7.3.1 to 1.7.3.2 on pro- rata basis (for measured and accepted quantity).

Sl. No.	Activity/ work description	% of unit rate
1.7.3.1	On completion of field work and submission of data in line with respective item (for the measured and accepted quantity)	50%
1.7.3.2	On submission of final report to BHEL/ PEM and duly accepted and approved by BHEL/ PEM and against contractors invoice (for the measured and accepted quantity)	50%

Note:

- a. Detailed definition of the terms “DRAFT REPORT” & “FINAL REPORT”, preparation and submission of reports shall be in line with the technical specification attached.
- b. Retention amount applicable as per GCC.

1.7.4 **METHOD OF MEASUREMENT**

Mode of measurement shall be as per relevant IS 1200 in conjunction of IS code 3385. In case the same is also not available, the standard procedure adopted in CPWD shall be adopted. In case, the same is also not available in CPWD, the measurement of the work done will be based on the mutual agreement between BHEL and contractor. In all the above cases, the interpretation of BHEL will be final and binding to the contractor. Measurement guidelines as a ready reference is also available in the technical specification.

1.7.5 **NO CLAIM WHAT SO EVER MAY BE, WILL BE ENTERTAINED UNDER THIS CONTRACT, AFTER DULY SIGNING THE FINAL BILL ALONG WITH MEASUREMENT BOOKS AND ACCEPTED BY BHEL.**

**VOLUME-IA PART-I CHAPTER - VIII**  
**TAXES AND OTHER DUTIES**

**1.8.1 Goods and service Tax (GST) & Cess**

- 1.8.1.1 The successful bidder shall furnish proof of GST registration with GSTN Portal in the State in which the Project is being executed, covering the services under this contract. Registration should also bear endorsement for the premises from where the billing shall be done by the successful bidder on BHEL for this project/ work.
- 1.8.1.2 Contractor's price/rates shall be exclusive of GST & Cess (if applicable) (herein after termed as GST). Contractor shall submit to BHEL the GST compliant tax invoice/debit note/revised tax invoice on the basis of which BHEL will claim the input tax credit in its return. Since this is a works contract, the applicable rate shall be @ 18% GST, as applicable presently
- 1.8.1.3 Bidder shall note that the GST Tax Invoice complying with GST Invoice Rules wherein the 'Bill To' details will as below:  
BHEL GSTN - 33AAACB4146P2ZL  
NAME - BHARAT HEAVY ELECTRICALS LIMITED
- 1.8.1.4 GST charged in the tax invoice/debit note/revised tax invoice by the contractor shall be released separately to the contractor only after contractor files the outward supply details in GSTR-1 on GSTN portal and input tax credit of such invoice is matched with corresponding details of outward supply of the contractor and has paid the GST at the time of filing the monthly return.
- 1.8.1.5 In case BHEL has to incur any liability (like interest / penalty etc.) due to denial/reversal / delay of input tax credit in respect of the invoice submitted by the contractor, for the reasons attributable to the contractor, the same shall be recovered from the contractor.
- 1.8.1.6 Further, in case BHEL is deprived of the Input tax credit due to any reason attributable to contractor, the same shall not be paid or Recovered if already paid to the contractor.
- 1.8.1.7 Tax invoice/debit Note/revised tax invoice shall contain all such particulars as prescribed in GST law and comply to the timelines for issue of the same. Invoices shall be submitted on time to the concerned BHEL Engineer In Charge.
- 1.8.1.8 TDS under GST (if/ as & when applicable) shall be deducted at prevailing rates on gross invoice value from the running bills.

## TECHNICAL CONDITIONS OF CONTRACT (TCC)

---

1.8.1.9 E-way bills / Transit passes / Road Permits, if required for materials / T&P etc., bought into the project site is to be arranged by the Contractor only.

1.8.1.10 BHEL shall not reimburse any amounts towards any interest / penalty etc., incurred by contractor. Any additional claim at a later date due to issues such as wrong rates / wrong classification by contractor shall not be paid by BHEL.

### 1.8.2 **All taxes and duty other than GST & Cess**

The contractor shall pay all (except the specific exclusion viz GST & Cess) taxes, fees, license charges, deposits, duties, tools, royalty, commissions, Stamp Duties, or other charges / levies, which may be levied on the input goods & services consumed and output goods & services delivered in course of his operations in executing the contract and the same shall not be reimbursed by BHEL. In case BHEL is forced to pay any of such taxes, BHEL shall have the right to recover the same from his bills or otherwise as deemed fit.

### 1.8.3 **Statutory Variations**

Statutory variations are applicable under the GST Acts, against production of proof. The changes implemented by the Central / State Government during the tenure of the contract viz. increase / decrease in the rate of taxes, applicability, etc. and its impact on upward revision / downward revision are to be suitably paid/ adjusted from the date of respective variation. The bidder shall give the benefit of downward revision in favour of BHEL. No other variations shall be allowed during the tenure of the contract.

### 1.8.4 **New Taxes/Levies**

In case Government imposes any new levy / tax after submission of bid during the tenure of the contract, BHEL shall reimburse the same at actual on submission of documentary proof of payment subject to the satisfaction of BHEL that such new levy / tax is applicable to this contract.

### 1.8.5 **Direct Tax**

BHEL shall not be liable towards Income Tax of whatever nature including variations thereof arising out of this contract as well as tax liability of the bidder and their personnel. Deduction of tax at source at the prevailing rates shall be effected by BHEL before release of payment as a statutory obligation, unless exemption certificate is produced by the bidder. TDS certificate will be issued by BHEL as per the provisions of Income Tax Act.

**VOLUME-IA PART-I CHAPTER -IX**  
**BILL OF QUANTITY**

- 1.9.1 Bidders shall only quote “Total amount” in the format given in PART-B of the price bid. Any other entry elsewhere in the price bid shall be treated as Null and Void.
- 1.9.2 The above mentioned “Total amount” is for the entire Bill of Quantity (BOQ) given in Part-C of the Price bid.
- 1.9.3 BHEL has the pre-fixed the weightages for the amount of individual items of Bill of Quantity with respect to the “Total amount” in Part-C.
- 1.9.4 Based on the pre-fixed weightages, the amount for the individual items of the Bill of Quantity shall be arrived at. This amount shall be rounded off to the nearest rupee.
- 1.9.5 Based on the quantities of individual item and the amount arrived in SI NO. 1.9.4 above, unit rate of individual items shall be derived. This unit rate shall be rounded off to four decimal places.
- 1.9.6 Bidder to note that this is an item rate contract. Payment shall be made for the actual quantities of work executed at the unit rate arrived at as per SI NO. 1.9.5 above.

**VOLUME-IA PART-I CHAPTER -X**  
**GENERAL**

**In addition to the clause 2.8 of General Conditions of Contract (Volume-IC of Book-II) the contractor shall comply with the following.**

- 1.10.1** Successful Bidder is requested to furnish the following at PSSR-HQ Chennai immediately after release of Letter of Intent (LOI)
- i. Security Deposit and Additional Security Deposit (As applicable).
  - ii. Unqualified Acceptance for Detailed LOI/ Work Order.
- 1.10.2** Successful Bidders are requested to furnish the proof of documents for the following at PSSR- Site.
- i. PF Regn No.
  - ii. Labour License No.
  - iii. Workmen Insurance Policy No.
- 1.10.3 BOCW Act & BOCW Welfare Cess Act**
- 1.10.3.1** The Contractor Should Register their Establishment under BOCW Act 1996 read with rules 1998 by submitting Form I (Application for Registration of Establishment) and Form IV (Notice of Commencement /Completion of Building Other Construction Work) to the respective Labour Authorities i.e.,
- a) Assistant Labour Commissioner (Central) in respect of the project premises which is under the purview of Central Govt.–NTPC, NTPL etc.
  - b) Appropriate State authorities in respect of the project premises which is under the purview of State Govt.
- 1.10.3.2** The Contractor Should comply with the provisions of BOCW Welfare Cess Act 1996 in respect of the work awarded to them by BHEL
- 1.10.3.3** The contractor should ensure compliance regarding Registration of Building Workers as Beneficiaries, Hours of work, welfare measures and other conditions of service with particular reference to Safety and Health measures like Safety Officers, safety committee, issue of Personal protective equipments, canteen, rest room, drinking water, Toilets, ambulance, first aid centre etc.

## TECHNICAL CONDITIONS OF CONTRACT (TCC)

---

- 1.10.3.4 The contractor irrespective of their nature of work and manpower (Civil, Mechanical, Electrical works etc) should register their establishment under BOCW Act 1996 and comply with BOCW Welfare Cess Act 1996.
- 1.10.3.5 Contractor shall make remittance of the BOCW cess as per Act in consultation with BHEL as per the rates in force (presently 1%). BHEL shall reimburse the same upon production of documentary evidence. However, BHEL shall not reimburse the Fee paid towards the registration of establishment, fees paid towards registration of beneficiaries and contribution of beneficiaries remitted.
- 1.10.3.6 Non-compliance to provisions of the BOCW act and BOCW welfare Cess act is not acceptable. In case of any non-compliance, BHEL reserves the right to withhold any sum it deems fit. Only upon total compliance to the BOCW act and also discharge of total payment of Cess under the BOCW Cess act by the contractor, BHEL shall consider refund of the amounts.

### **1.10.4 PROVIDENT FUND**

- 1.10.4.1 The contractor is required to extend the benefit of Provident Fund to the labour employed by the contractor in connection with this contract as per the Employees Provident Fund and Miscellaneous Provisions Act 1952. For due implementation of the same, the contractor is hereby required to get themselves registered with the Provident Fund authorities for the purpose of reconciliation of PF dues and furnish to us the code number allotted to them by the Provident Fund authorities within one month from the date of issue of this letter of intent. In case the contractor is exempted from such remittance an attested copy of authority for such exemption is to be furnished. Please note that in the event of contractor's failure to comply with the provisions of said Act, if recoveries therefore are enforced from payments due to BHEL by the customer or paid to statutory authorities by BHEL, such amount will be recovered from payments due to the contractor.
- 1.10.4.2 The final bill amount would be released only on production of clearance certificate from PF / ESI and labour authorities as applicable.

### **1.10.5 OTHER STATUTORY REQUIREMENTS**

- 1.10.5.1 The Contractor shall submit a copy of Labour License obtained from the Licensing Officer (Form VI) u/r25 read with u/s 12 of Contract Labour (R&A) Act 1970 & rules and Valid WC Insurance copy or ESI Code (if applicable) and PF code no along with the first running bill.

## TECHNICAL CONDITIONS OF CONTRACT (TCC)

---

- 1.10.5.2 The contractor shall submit monthly running bills along with the copies of monthly wages (of the preceding month) u/r78(1)(a)(1) of Contract Labour Rules, copies of monthly return of PF contribution with remittance Challans under Employees Provident Fund Act 1952 and copy of renewed WC Insurance policy or copies of monthly return of ESI contribution with Challans under ESI Act 1948 (if applicable) in respect of the workmen engaged by them.
- 1.10.5.3 The Contractor should ensure compliance of Sec 21 of Contract Labour (R&A) Act 1970 regarding responsibility for payment of Wages. In case of “Non-compliance of Sec 21 or non-payment of wages” to the workmen before the expiry of wage period by the contractor, BHEL will reserve its right to pay the workmen under the orders of Appropriate authority at the risk and cost of the Contractor.
- 1.10.5.4 The Contractor shall submit copies of Final Settlement statement of disbursal of retrenchment benefits on retrenchment of each workman under I D Act 1948, copies of Form 6-A (Annual Return of PF Contribution) along with Copies of PF Contribution Card of each member under PF Act and copies of monthly return on ESI Contribution – Form 6 under ESI Act 1948 (If applicable) to BHEL along with the Final Bill.
- 1.10.5.5 In case of any dispute pending before the appropriate authority under I D act 1948, WC Act 1923 or ESI Act 1948 and PF Act 1952, BHEL reserve the right to hold such amounts from the final bills of the Contractor which will be released on submission of proof of settlement of issues from the appropriate authority under the act.
- 1.10.5.6 In case of any dispute prolonged/pending before the authority for the reasons not attributable to the contractor, BHEL reserves the right to release the final bill of the contractor on submission of Indemnity bond by the contractor indemnifying BHEL against any claims that may arise at a later date without prejudice to the rights of BHEL

### **1.10.6 DEPLOYMENT OF SKILLED / SEMI-SKILLED TRADESMEN**

The following clause is applicable in case the contract value / contract price is Rs. Five crores and above. The contractor shall, at all stages of work deploy skilled / semi-skilled tradesmen who are qualified and possess certificate in particular trade from CPWD Training Institute / Industrial Training. Institute / National Institute of Construction Management and Research (NICMAR), National Academy of Construction, CIDC or any similar reputed and recognized Institute managed / certified by State / Central Government. The number of such qualified tradesmen shall not be

# TECHNICAL CONDITIONS OF CONTRACT (TCC)

---

less than 20% of total skilled / semi-skilled workers required in each trade at any stage of work. The contractor shall submit number of man days required in respect of each trade, its scheduling and the list of qualified tradesmen along with requisite certificate from recognized Institute to Engineer-in- Charge for approval. Notwithstanding such approval, if the tradesmen are found to have inadequate skill to execute the work of respective trade, the contractor shall substitute such tradesmen within two days of written notice from Engineer-in-Charge. Failure on the part of contractor to obtain approval of Engineer-in-Charge or failure to deploy qualified tradesmen will attract a compensation to be paid by contractor at the rate of Rs. 100 per such tradesman per day. Decision of Engineer-in-Charge as to whether particular tradesman possesses requisite skill and amount of compensation in case of default shall be final and binding.

## **1.10.7 GENERAL**

### **1.10.7.1 Site Visit by the Bidder**

The bidder shall, prior to submitting his tender for the work, visit, examine the site of works and its surroundings at his own expense, and obtain and ascertain for himself on his own responsibility all information that may be necessary for preparing his tender and entering into a contract, and take the same into account in the quoted contract price for the work.

The bidder shall satisfy themselves about the following factors:

- i. Site conditions including access to the site, existing and required roads and other means of transport/communication for use by him in connection with the work including diverting and re-routing of services.
- ii. Requirement and availability of land and other facilities of his enabling works, establishment of his nursery, office, stores etc.
- iii. Ground conditions including those bearing upon transportation, disposal, handling and storage of materials required for the work or obtained there- from.
- iv. Source and extent of availability of suitable materials, including water etc., and labour (skilled and unskilled) required for work, and laws and regulations governing their use and employment.
- v. Geological, meteorological, topographical and other general features of the site and its surroundings as are pertaining to and needed for the performance of the work.

## TECHNICAL CONDITIONS OF CONTRACT (TCC)

---

- vi. The limit and extent of surface and subsurface water to be encountered during the performance of the work, and the requirement of drainage and pumping.
  - vii. The type of equipment and facilities needed, for and in the performance of the work.
  - viii. The extent of lead and lift required for the work in complete form over the entire duration of the contract, and
  - ix. All other information pertaining to and needed for the work including information as to the risks, contingencies and other circumstances which may influence or affect the work or the cost thereof under this contract.
- 1.10.7.2 The bidder should note that information, if any, in regard to the local conditions, as contained in these tender documents, has been given to tenderer merely for guidance and is not warranted to be complete.
- 1.10.7.3 A bidder shall be deemed to have full knowledge of the site, whether he inspects it or not, and no extra charges consequent on any misunderstanding or otherwise shall be allowed.
- 1.10.7.4 The bidder and any of his personnel or agents will be granted permission by the Site-In-Charge or his authorized nominee, on receipt of formal application in respect thereof a week in advance of the proposed date of inspection of site, to enter upon his premises and lands for purpose of such inspection, but only on the express condition that the tenderer (and his personnel and agents) will relieve and indemnify the Employer (and his personnel and agents) from and against all liability in respect thereof and will be responsible for personal injury (whether fatal or otherwise), loss of or damage to property and any other loss, damage, costs and expenses however caused which, but for the exercise of such permission, would not have arisen.
- 1.10.7.5 All works shall be carried out in proper workmen like manner. Items of works covered by the following specification shall be carried out as per the best practices and according to the direction of the Engineer In-charge / BHEL, Site Engineer and to his satisfaction. Unless otherwise specified in this section or in the description of item, the cost of stage of works mentioned here under shall be deemed to have been included in the rates of items provided in the schedule
- 1.10.7.6 Scope of work covered under this specification requires quality workmanship, engineering and construction management. The contractor shall ensure timely completion of work. The contractor shall have adequate tools, measuring instruments, etc. in his possession. He shall also have adequate trained, qualified and experienced

## TECHNICAL CONDITIONS OF CONTRACT (TCC)

---

engineers, supervisory staff and skilled personnel. The manpower deployment identified by contractor shall match with above scope of works.

- 1.10.7.7 It is not the intent to specify herein all details of all material. Any item related this work not covered by this but necessary to complete the system will be deemed to have been included in the scope of the work
- 1.10.7.8 All the necessary certificates and licenses required to carry out this scope of work are to be arranged by the contractor then and there at no extra cost.
- 1.10.7.9 Site testing wherever required shall be carried out for all items / materials installed by the contractor to ensure proper installation and functioning in accordance with drawings, specifications and manufacturer's recommendations.
- 1.10.7.10 The contractor shall carryout additional tests, if any, which the Engineer feels necessary because of site conditions and also to meet system specification
- 1.10.7.11 The work shall be executed under the usual conditions without affecting power plant construction and in conjunction with other operations and contracting agencies at site. The contractor and his personnel shall co- operate with the personnel of other agencies, co-ordinate his work with others and proceed in a manner that shall not delay or hinder the progress of work as a whole.
- 1.10.7.12 The Contractor may have to execute work in such a place and condition where other agencies also will be under such circumstances. The contractor shall co-operate with other contractors and agencies so that various activities can be carried out simultaneously in order to achieve an early completion
- 1.10.7.13 All the work shall be carried out as per instructions of BHEL engineer. BHEL engineer's decision regarding the correctness of the work and method of working shall be final and binding on the contractor.
- 1.10.7.14 Wherever Work sequences are furnished by BHEL, the contractor shall follow the same sequence.
- 1.10.7.15 Contractor shall execute the supply and works as per sequence prescribed by BHEL at site engineer. No claims for extra payment from the contractor will be entertained on the grounds of deviation from the methods of execution of similar job in any other site or for any reasons whatsoever.
- 1.10.7.16 If required by BHEL, the contractor shall change the sequence of his operation so that work on priority sectors can be completed within the projects schedule. The contractor shall afford maximum assistance to BHEL in this connection without causing delay to agreed completion date.

## TECHNICAL CONDITIONS OF CONTRACT (TCC)

---

- 1.10.7.17 Contractor shall, transport all materials to site and unload at site / working area for inspection and checking. All material handling equipment required shall be arranged by the contractor.
- 1.10.7.18 The contractor will be responsible for the safe custody and proper accounting of all materials in connection with the work.
- 1.10.7.19 The contractor must obtain the signature and permission of the security personnel of the customer for bringing any of their materials inside the site premises. Without the Entry Gate Pass these materials will not be allowed to be taken outside
- 1.10.7.20 Contractor shall retain all T&Ps, Material handling equipments etc at site as per advice of BHEL engineer and same shall be taken out from site only after getting the clearances from Engineer In-charge.
- 1.10.7.21 The contractor at his cost shall arrange necessary security measures for adequate protection of his machinery, equipment, tools, materials etc. BHEL shall not be responsible for any loss or damage to the contractor's construction equipment and materials. The contractor may consult the Engineer-in-Charge on the arrangements made for general site security for protection of his machinery equipment tools etc.
- 1.10.7.22 Any wrong erection shall be removed and re-erected promptly to comply with the design requirements to the satisfaction of Site Engineer
- 1.10.7.23 The Contractor may have to execute work in such a place and condition where other agencies also will be under such circumstances. However, completion time for construction, agreed will be subject to the condition that contractor's work is not hampered by the agencies.
- 1.10.7.24 Contractor has to work in close co-ordination with other agency at site. BHEL engineer will co-ordinate area clearance. In a project of such magnitude, it is possible that the area clearance may be less / more at a particular given time. Activities and Construction program have to be planned in such a way that the milestones are achieved as per schedule/ plans. Contractor shall arrange & augment the resources accordingly.
- 1.10.7.25 Contractor shall remove all scrap materials periodically generated from his working area in and around power station and collect the same at one place earmarked for the same. Failure to collect the scrap is likely to lead to accidents and as such BHEL reserves the right to collect and remove the scrap at contractor's risk and cost if there is any failure on the part of contractor in this respect. All the package materials, including special transporting frames, etc. shall be returned to the BHEL stores by the contractor.

## TECHNICAL CONDITIONS OF CONTRACT (TCC)

---

- 1.10.7.26 The contractor shall ensure that his premises are always kept clean and tidy to the extent possible. Any untidiness noted on the part of the contractor shall be brought to the attention of the contractor's site representative who shall take immediate action to clean the surroundings to the satisfaction of the Engineer-in-Charge.
- 1.10.7.27 The contractor is strictly prohibited from using BHEL's regular components like angles, channels, beams, plates, pipe / tubes, and handrails etc. for any temporary supporting or scaffolding works. Contractor shall arrange himself all such materials. In case of such misuse of BHEL materials, a sum as determined by BHEL engineer will be recovered from the contractor's bill. The decision of BHEL engineer is final and binding on the contractor.
- 1.10.7.28 No member of the already erected structure / platform, pipes, grills, platform, other component and auxiliaries should be cut without specific approval of BHEL engineer.
- 1.10.7.29 Contractors shall ensure that all their Staff / Employees are exposed to periodical training programme conducted by qualified agencies/ personnel on ISO 9001 - 2015 Standards.
- 1.10.7.30 The terminal points decided by BHEL are final and binding on the contractor for deciding the scope of work and effecting the payment for the work done up to the terminals.
- 1.10.7.31 Crane operators deployed by the contractor shall be tested by BHEL before he is allowed to operate the cranes.
- 1.10.7.32 On Completion of work, all the temporary buildings, structures, pipe lines, cable etc. shall be dismantled and leveled and debris shall be removed as per instruction of BHEL by the contractor at his cost. In the event of his failure to do so, the expenditure towards clearance of the same will be recovered from the contractor. The decision of BHEL Engineer in this regard is final.
- 1.10.7.33 It is the responsibility of the contractor to do the checking, testing etc. if necessary, repeatedly to satisfy BHEL Engineer with all the necessary tools and tackles, manpower etc. without any extra cost. The testing will be completed only when jointly certified so, by the BHEL Engineer.
- 1.10.7.34 The contractor shall ensure that his premises are always kept clean and tidy to the extent possible. Any untidiness noted on the part of the contractor shall be brought to the attention of the contractor's site representative who shall take immediate action to clean the surroundings to the satisfaction of the Engineer-in-Charge.
- 1.10.7.35 If any item not covered but requires being executed, same shall be carried out by the contractor. Equivalent or proportional unit rate shall be considered wherever possible

## TECHNICAL CONDITIONS OF CONTRACT (TCC)

---

from the BOQ. The rates quoted by the contractor shall be uniform as far as possible for similar items appearing in rate schedule.

- 1.10.7.36 The contractor's work shall not hinder other work, either underground or over ground, such as electrical, phone lines, water or sewage lines, etc. In areas of overlap, the contractor shall work in coordination with other related contractors. Any damage by the landscape contractor's team to such utilities will be penalized and contractor shall be responsible for cost for such damages.
- 1.10.7.37 Contractor shall retain all T&Ps, Material handling equipments etc at site as per advice of BHEL engineer and same shall be taken out from site only after getting the clearances from Engineer In charge

### **1.10.8 SITE INSPECTION**

- 1.10.8.1 BHEL or his authorized agents may inspect various stages of work during the currency of the contract awarded to him. The contractor shall make necessary arrangements for such inspection and carry out the rectification pointed out by the owner / employer without any extra cost to the owner / employer. No cost whatsoever such duplication of inspection of work be entertained.
- 1.10.8.2 BHEL will have full power and authority to inspect the works at any time, either on the site or at the contractor's premises. The contractor shall arrange every facility and assistance to carry out such inspection. On no account will the contractor be allowed to proceed with work of any type unless such work has been inspected and entries are made in the site inspection register by BHEL
- 1.10.8.3 Wherever the performance of work by the contractor is not satisfactory in respect of workmanship, deployment of sufficient labour or equipment, delay in execution of work or any other matter, BHEL shall have the right to engage labour at normal ruling rates and get the work executed through other agency and debit the cost to the contractor and the contractor shall have no right to claim compensation thereof. In such a case, BHEL shall have the right to utilize the materials and tools brought by the contractors for the same work

### **1.10.9 DOCUMENTATION**

- 1.10.9.1 The following information shall be furnished by the bidder within two weeks of award of contract for purchaser's approval:
- a) Bar chart covering planned activities at site
  - b) Detailed organization chart

## TECHNICAL CONDITIONS OF CONTRACT (TCC)

---

c) Details of T&P available with contractors with documents proofs.

1.10.9.2 The following information shall be furnished by the bidder after testing and inspection: Test certificates of various tests conducted at site. All inspection and test certificates shall be signed by BHEL representative also.

### **1.10.10 RECORDS TO BE MAINTAINED AT SITE:**

1.10.10.1 Record of Quantity of FREE/Chargeable items issued by BHEL must be maintained during contract execution. Also reconciliation statement to be prepared at regular intervals.

1.10.10.2 The under mentioned Records/ Log-books/ Registers applicable to be maintained.

- i. Site Order Book.
- ii. Test Check of measurements.
- iii. Records of Test reports of Field tests.
- iv. Records of manufacture's test certificates.
- v. Records of disposal of scraps generated during and after the work completion.

**VOLUME-IA PART – II CHAPTER 1**  
**CORRECTIONS / REVISIONS IN SPECIAL CONDITIONS OF**  
**CONTRACT, GENERAL CONDITIONS OF CONTRACT AND**  
**FORMS & PROCEDURES**

**SI No: 1**

Clause 4.1.11 of SCC is deleted.

**SI No: 2**

**OCCUPATIONAL HEALTH, SAFETY & ENVIRONMENT MANAGEMENT/ QUALITY ASSURANCE PROGRAMME**

The following clauses in Occupational Health, Safety & Environment Management / Quality Assurance Programme published in Chapter-IX of Special Conditions of Contract (Volume I Book-II) is revised as under.

**Chapter IX Clause 9.1 is modified as below:**

Contractor will comply with HSE (Health, Safety & Environment) requirements of BHEL as per the “HSE Plan for Site Operations by Subcontractor” (Document No. HSEP: 14 Rev01) enclosed.

**Chapter IX Clause 9.1.1 to 9.1.25 stands deleted.**

**Chapter IX Clause 9.2 to 9.62 stands deleted.**

**SI No: 3**

**Clause No. 10.5 on RA Bill Payments, in Special Conditions of Contract (SCC), Volume-IB, Book-II, is revised as under:**

The payment for running bills will normally be released within 30 days of submission of running bill complete in all respects with all documents. It is the responsibility of the contractor to make his own arrangements for making timely payments towards labour wages, statutory payments, outstanding dues etc., and other dues in the meanwhile.

# TECHNICAL CONDITIONS OF CONTRACT (TCC)

---

## **SI No.: 4**

### **EARNEST MONEY DEPOSIT**

The EARNEST MONEY DEPOSIT (EMD) clause 1.9 published in General Conditions of Contract (Volume IC Book-II) is revised as under.

**Void (Explanation: EARNEST MONEY DEPOSIT is not applicable for this tender).** Bid Security Declaration: Bidders to submit Bid Security Declaration as per format provided in NIT.

## **SI No: 5**

**The following clause is added under clause 1.10 Security Deposit in General Conditions of Contract (Volume I Book II):** “1.10.8 Bidder agrees to submit Security Deposit required for execution of the contract within the time period mentioned. In case of delay in submission of Security Deposit, enhanced Security Deposit which would include interest (Base rate of SBI +6%) for the delayed period, shall be submitted by the bidder. Further, if Security Deposit is not submitted till such time the first bill becomes due, the amount of Security Deposit due shall be recovered as per terms defined in NIT/contract, from the bills along with due interest.”

## **SI No.: 6**

### **EARNEST MONEY DEPOSIT**

The **EXECUTION OF CONTRACT AGREEMENT** clause 1.14 published in General Conditions of Contract (Volume IC Book-II) is revised as under.

### **1.14 EXECUTION OF CONTRACT AGREEMENT**

**Void (Explanation: EXECUTION OF CONTRACT AGREEMENT is not applicable for this tender).**

## **SL No: 7**

The OVERRUN COMPENSATION (ORC) clause 2.12 published in General Conditions of Contract (Volume I Book II) is revised as under.

### **2.12 OVERRUN COMPENSATION (ORC)**

**Void (Explanation: Over Run Compensation is not applicable for this tender.)**

## **SI No: 8**

The PRICE VARIATION COMPENSATION (PVC) clause 2.17 published in General Conditions of Contract (Volume IC Book-II) is revised as under.

### **2.17 PRICE VARIATION COMPENSATION**

**Void (Explanation: Price Variation Compensation is not applicable for this tender.)**

# TECHNICAL CONDITIONS OF CONTRACT (TCC)

---

## **SI. No: 9**

**Clause 2.14.1 on Quantity Variation in General Conditions of Contract (GCC), Volume- IC, Book- II is revised as under:**

2.14.1 “The quantities given in the contract are tentative and may change to any extent (both in plus side and minus side). The derived item rates (as mentioned above) for individual items shall remain firm irrespective of any variations in the individual quantities. No compensation becomes payable in case the variation of the final executed contract value is within the limit of Minus (-) 25% of awarded contract value.”

## **SI No: 10**

Procedure 2.3 that forms the part of Forms and Procedures is published in Volume IA Part II of this booklet (Volume-I Book-I).

## **SI No: 11**

**Reverse Auction** - The chapter Reverse auction procedure published in ‘Forms and Procedures’ of Volume I Book-II stands deleted. Revised Reverse Auction Guidelines 2021 available in the website <http://www.bhel.com> shall be applicable.

## **SI No: 12**

Existing format on Monthly Performance Evaluation of Contractor, as available in Form No F-14 of Volume ID Forms and procedure stands Deleted. Form No.- F-14 (Rev 01) is enclosed.

## **SI No: 13**

Existing format for BANK GUARANTEE FOR SECURITY DEPOSIT, as available in Form No. F-11 (Rev 00) of Volume ID Forms and procedures stands deleted. Refer Proforma of Bank Guarantee (in lieu of Security Deposit)-Form WAM 22 provided in Part-II of Volume-IA Technical Conditions of Contract.

# TECHNICAL CONDITIONS OF CONTRACT (TCC)

---

## **VOLUME-IA PART – II CHAPTER 2 to 7**

In the next 114 pages as below:

<b>Chapter</b>	<b>Details</b>	<b>No of sheets</b>
Chapter - 2	Standard Specification for Topographical Survey	11
Chapter - 3	Drawings (Tender Purpose Only)	01
Chapter - 4	Specific HSE Plan for Sub Contractors for Damanjodi project	82
Chapter - 5	Form 14 Rev 01	06
Chapter - 6	Proforma Of Bank Guarantee (In Lieu Of Security Deposit)-Form WAM 22	03
Chapter - 7	Procedure For Conduct Of Conciliation Proceedings	11



**STANDARD SPECIFICATION FOR  
TOPOGRAPHICAL SURVEY OF 1 X 600  
MW METTUR FGD**

SPEC. NO.	PE-DC-O2-601-C001		
VOLUME	IIB		
SECTION	D		
REV. NO.	0	DATE	06/10/2021
SHEET	1	OF	11

**STANDARD SPECIFICATION  
FOR  
TOPOGRAPHICAL SURVEY**

**1.0 GENERAL**

1.1 This specification covers the technical requirements for carrying out “**Topographical Survey and Allied Works**” for the entire area/areas indicated for locating the power plant and its other systems. The work shall be executed in accordance with the specification and good standard of practice necessary to fulfil the objectives of the survey work strictly in accordance with the instruction and satisfaction of the engineer-in-charge.

**2.0 SCOPE**

2.1 The scope of work includes the following.

2.1.1 Carrying out topographical survey and preparation of plans (maps) and report of the entire area/areas indicated for locating the power plant and its other systems.

2.1.2 Carrying out bench mark ( GTS / any other reference bench mark approved by the engineer-in-charge) to site/sites under survey by parallel levelling, establishing and constructing bench mark, grid and reference pillars in the field.

2.1.3 Spot level survey of the entire area/areas at specified intervals and development of contours.

2.1.4 Carrying out cross-section of canal/nallah as specified in the schedule of quantities by taking spot levels at 5m interval or less depending upon the site conditions and instructions of the engineer-in-charge.

2.1.5 Providing survey instruments, construction equipments, tools & plants, materials, labours, qualified surveyors, clearance of jungles, cutting of trees, earth work, scaffoldings, transport, supervision by competent engineers/surveyors, testing of materials, full insurance and all other incidental items as may be necessary for successful completion of the surveying , mapping and construction works etc.



**STANDARD SPECIFICATION FOR  
TOPOGRAPHICAL SURVEY OF 1 X 600  
MW METTUR FGD**

SPEC. NO.	PE-DC-O2-601-C001		
VOLUME	IIB		
SECTION	D		
REV. NO.	0	DATE	06/10/2021
SHEET	2	OF	11

2.1.6 Furnishing all field data and drawings on floppies apart from hard copies.

2.1.7 Furnishing survey report as described in details in the succeeding paragraphs is also included in the scope of work.

### **3.0 TENDER DRAWING**

3.1 The enclosed Topographical Survey Layout indicate the tentative location of the area/areas to be surveyed for locating the project. The location/area(s) indicated in the drawing is subject to change that may be necessary during actual execution of the work. The work shall be carried out as per the instructions of the engineer-in-charge.

3.2 The bidder must visit the site prior to submitting his quotations to acquaint himself fully with the nature, type, scope of work and involvement therein. The rates quoted shall remain firm during the entire period of execution till completion of the work and any additional claim for lack of knowledge shall not be entertained.

### **4.0 SPECIFICATION**

4.1 The work shall be executed according to the specification and good standard of practice necessary to fulfil the objectives of the survey work strictly in accordance with the instruction and satisfaction of the engineer-in-charge.

4.2 The specification shall be read in conjunction with the description of items in the schedule of quantities. The bidder shall refer to the employer for any discrepancy which may exist between the drawings, specification and corresponding items of the schedule for clarification before submission of quotation and the employer's decision as to the clarity of the point raised shall be final and binding on the bidder.

4.3 The work at site shall be carried out under the full time supervision by a qualified engineer or a senior surveyor. The engineer or senior surveyor shall be responsible for and capable of co-ordinating the work of the surveying teams, setting out the work accurately, identifying immediately and positively the type of instruments to be deployed and the methodology of surveying to achieve speed and accuracy in the work and



**STANDARD SPECIFICATION FOR  
TOPOGRAPHICAL SURVEY OF 1 X 600  
MW METTUR FGD**

SPEC. NO.	PE-DC-O2-601-C001		
VOLUME	IIB		
SECTION	D		
REV. NO.	0	DATE	06/10/2021
SHEET	3	OF	11

shall be fully conversant with the theory and techniques of traversing, triangulation, spot levelling survey work etc covered by this contract.

- 4.4 The contractor shall be responsible for the proper execution of the work to such lines and grades as specified in the specification, drawings or as directed by the engineer-in-charge from time to time.
- 4.5 After arrival of the instruments to site, these shall not be moved out of the site by the contractor without the prior written permission and approval of the engineer-in-charge. In case the instruments are moved out of the site without the prior written permission and approval, the engineer-in-charge/owner reserves the right to deduct from the contractor's bill(s) the amount as considered reasonable and or to withheld the payments for the work done. The decision of the engineer-in-charge in this regard shall be final and binding on the contractor.

**5.0 CARRYING OUT AND SETTING UP OF BENCH MARK & REFERENCE PILLARS**

- 5.1 The contractor shall carry out bench mark by fly-levelling from the nearest GTS bench mark or available source as approved by the engineer-in-charge and establish the same on a permanent bench mark to be constructed as per **Fig.1** at a convenient location(s) at site as per the instructions of the engineer-in-charge. All subsequent transfer of levels shall be carried out with respect to this bench mark.
- 5.2 The work shall also include constructing permanent reference pillars as per **Fig.2** at suitable locations as approved by the engineer-in-charge. These reference pillars shall be labelled permanently with their respective co-ordinates and reduced levels for future use. The bench mark and reference pillars shall be shown on the survey drawings.
- 5.3 The fly levelling should be carried out using two good quality levels simultaneously. The levelling instruments should always be kept free of collimation error which should be checked and adjusted before start of the work every day. A record of adjustments should be kept in the field book.
- 5.4 While carrying bench mark to the project site, levels shall be established on the permanent objects like culverts etc at least on one object in every



**STANDARD SPECIFICATION FOR  
TOPOGRAPHICAL SURVEY OF 1 X 600  
MW METTUR FGD**

SPEC. NO.	PE-DC-O2-601-C001		
VOLUME	IIB		
SECTION	D		
REV. NO.	0	DATE	06/10/2021
SHEET	4	OF	11

500m along the route with adequate description about the objects and levels to be mentioned in the level book/survey report to facilitate locating these objects later on. The route for transferring levels shall follow the existing roads as far as possible and this route shall require the approval of the engineer-in-charge before the commencement of work.

- 5.5 Closing error in levelling should be limited to  $12 \sqrt{L}$  mm, where L is the length of the route in km.
- 5.6 Payment shall be made on the basis of shortest length of the said route measured between the original reference bench mark and the bench mark to be established at site.

## **6.0 TOPOGRAPHICAL SURVEY AND MAPPING**

- 6.1 Positions both in plan and elevation of all natural and artificial features of the area like waterways, railway tracks, trees, cultivation, houses/any structure, fences, pucca and kutcha roads including culverts and crossings, foot tracks, other permanent objects like telephone posts and transmission towers etc are to be established and subsequently be shown on survey maps by means of conventional symbols (preferably symbols of Survey of India maps). All earth deposits, depressions, hills and valleys within the area/areas are to be surveyed and plotted on maps by contours. Necessary levelling work of the entire area/ areas are to be surveyed and plotted on maps by establishing horizontal location so that location and sketching of contours for the area/ areas can be done at specified intervals and in specified scales on maps. In case of steep slopes and dense jungle etc where gridding is not possible, the method of survey, contour intervals etc shall be decided by the engineer-in-charge at site. Any unusual condition or formations on the ground, location of rock outcrops and springs/falls etc shall also be noted and plotted on the maps.
- 6.2 The field work shall be done with total station equipment in the following steps.
- Establishing horizontal and vertical controls and locating reference grids and bench mark in the area.
  - Surveying for establishing spot levels and plotting contours.



**STANDARD SPECIFICATION FOR  
TOPOGRAPHICAL SURVEY OF 1 X 600  
MW METTUR FGD**

SPEC. NO.	PE-DC-O2-601-C001		
VOLUME	IIB		
SECTION	D		
REV.NO.	0	DATE	06/10/2021
SHEET	5	OF	11

iii) Surveying for locating natural and man made details as described earlier.

6.3 The grids for the survey work shall be established in N-S & E-W direction corresponding to magnetic north or the plant north as directed by the engineer-in-charge.

## **7.0 TRAVERSING**

7.1 Triangulation or traversing or a combination of both shall be adopted for the purpose of establishing horizontal control and in order to determine the exact relationship between various existing points on the ground so that surveys required under the present scope of work and in future may be co-related and tied together.

7.2 Total intelligent station instruments should be deployed to achieve the specified accuracy of the work. Proper precautions for avoiding graduation errors, instrumental and personal errors should be scrupulously observed.

7.3 From main traverse/triangulation station, subsidiary stations shall be established at suitable interval to cover the entire area. Level of these stations shall be based on the bench mark established in the survey area. Occupying the main & subsidiary stations, all major details shall be surveyed by total station equipment. Further classification of details if necessary shall be carried out by plane table method.

7.4 The closing error in traverse shall not exceed one in twenty five thousand (1 in 25000) in terms of length or  $L\sqrt{N}$  seconds (total in angular measurement) whichever is less (where L is the least count of the instrument and N is the number of stations).

## **8.0 CONTOURING**

8.1 Contractor shall carry out spot level surveying at an interval of 10m for contouring the area/areas. Levels shall also be taken on all traverse stations and on salient points located at random over the area (ground points). Contours are to be interpolated at 0.5m intervals after the above points are plotted. The contours shall not be just interpolated but properly surveyed on the ground so that features falling between the two



**STANDARD SPECIFICATION FOR  
TOPOGRAPHICAL SURVEY OF 1 X 600  
MW METTUR FGD**

SPEC. NO.	PE-DC-O2-601-C001		
VOLUME	IIB		
SECTION	D		
REV. NO.	0	DATE	06/10/2021
SHEET	6	OF	11

successive levels are also picked up. Sufficient points properly distributed over the entire area shall be located and levels taken so that accurate contouring can be done. At places of sharp curvature or abrupt change in direction and elevation, points selected shall be close to each other. Salient points on ridge lines and valley lines shall also be measured.

- 8.2 Cross-section of canal/nallah if any shall be prepared by taking spot levels at 5m interval or less depending upon the site conditions and instructions of the engineer-in-charge. For contouring within reservoirs /ponds sounding technique shall be adopted.
- 8.3 Levelling operation shall always start from main/subsidiary stations whose levels are based on the bench mark established in the survey area and end on the same.
- 8.4 Closing error in levelling shall not exceed the limit mentioned in clause 5.5.

**9.0 CONSTRUCTION OF BENCH MARK, REFERENCE & GRID PILLARS**

- 9.1 Bench marks shall be constructed as per the sketch at **Fig - 1** for each isolated area as per the directions of the engineer-in-charge. The reduced level of the top of hemispherical ball and co-ordinates with respect to survey grid shall be engraved clearly on the top of the bench mark pillar. The top surface of MS plate alongwith the hemispherical ball shall be painted with anticorrosive paint.
- 9.2 There shall be one reference pillar constructed within one meter of each bench mark pillar as per the sketch at **Fig - 2**. The relation of these pillars with respect to the bench mark pillar and survey grids should be established and indicated in the drawings. The reduced levels and co-ordinates should be transferred & punched on the top of the steel plate of reference pillars. The top surface of MS plate shall be painted with anticorrosive paint.
- 9.3 Grid pillars as per the enclosed sketch at **Fig - 2** shall be constructed at the intersection of the 200m grid lines which should be established at site in N-S and E-W direction corresponding to magnetic north or plant north



**STANDARD SPECIFICATION FOR  
TOPOGRAPHICAL SURVEY OF 1 X 600  
MW METTUR FGD**

SPEC. NO.	PE-DC-O2-601-C001		
VOLUME	IIB		
SECTION	D		
REV. NO.	0	DATE	06/10/2021
SHEET	7	OF	11

or as directed by the engineer-in-charge and their co-ordinates with reference to the survey grids shall be engraved on the top of the pillars. The top surface of MS plate shall be painted with anticorrosive paint. The pillars should be white washed.

- 9.4 The payment shall be made on the number of bench mark and reference/grid pillars actually constructed at site as per the directions of the engineer-in-charge.

### **10.0 Route Survey**

- 10.1 Route Survey shall be conducted along a narrow strip/belt of the terrain selected after field reconnaissance or as directed by Owner/Engineer at Site. Topographical survey for existing storm drainage lines as well as for routing pipe lines, transportation and communication lines, etc. shall be conducted. Longitudinal profiles as well as cross-sections shall be taken at 50 m intervals or less in nearly flat/undulating terrains and at 20 m intervals in hilly terrains, as per direction of the Owner/Engineer. All cross-sections shall be with reference to centre line of corridor showing levels at every 2 - 5 metre intervals and all breaks in the profile. The width of strip/corridor shall be as specified in the drawing or as directed by Owner/Engineer.

### **11.0 PROGRESS REPORT**

- 11.1 The contractor shall prepare and submit progress report in three copies every week to the engineer-in-charge without fail indicating status of setting out of the grids, total area surveyed, grid pillars constructed, methodology adopted for surveying and instruments deployed including staff working on the site and difficulties encountered during execution of the work etc.
- 11.2 The submission of such reports and review thereof by the engineer-in-charge shall not be deemed to absolve the contractor of his responsibility of timely completion of the assignment as per the time schedule indicated.

### **12.0 PREPARATION & SUBMISSION OF SURVEY MAPS**



**STANDARD SPECIFICATION FOR  
TOPOGRAPHICAL SURVEY OF 1 X 600  
MW METTUR FGD**

SPEC. NO.	PE-DC-O2-601-C001		
VOLUME	IIB		
SECTION	D		
REV. NO.	0	DATE	06/10/2021
SHEET	8	OF	11

12.1 The contractor shall submit survey maps of the site in 1:1000 scale indicating grid lines and contour lines, demarcating all permanent features like roads, railways, waterways, buildings, power lines, natural streams, trees etc. Project area should have two originals, one showing spot levels and contours (with contour line interval of 0.5m) with grid lines and other with grid lines, contour lines and permanent features.

12.2 All the maps should be prepared in digitised forms using Inkjet/Pen plotter and standard computer software like Autocad - 12/13/14 or auto civil on standard A-0 size polyester base film. The block of name plate of all the drawings should be as per BHEL standard.

12.3 The contractor shall submit three copies of all the maps for review and approval of the engineer-in-charge. After approval, 6(six) prints of all the final maps alongwith a set of the originals on polyester base film and a floppy shall be submitted. Copies of the maps shall be submitted in proper flappers and original polyester base drawings should be handed over in proper card board covers indicating index of drawings.

12.4 Payment shall be made on the area actually surveyed as covered by the plan.

**13.0 SUBMISSION OF FIELD DATA AND REPORT**

13.1 Contractor shall submit all data pertaining to the survey in original to the engineer-in-charge.

13.2 All field data shall be submitted to the engineer-in-charge from time to time as per progress of the work.

13.3 Three copies of draft report shall be submitted on the completion of the field work for review and approval of the engineer-in-charge. The report should give the introduction of the site, methodology adopted for surveying the areas, calculation of errors, transfer of bench mark and any other calculation required for surveying and preparation of the survey maps.

13.4 Details of trees with their name, numbers and girths shall also form part of the survey report.



**STANDARD SPECIFICATION FOR  
TOPOGRAPHICAL SURVEY OF 1 X 600  
MW METTUR FGD**

SPEC. NO.	PE-DC-O2-601-C001		
VOLUME	IIB		
SECTION	D		
REV. NO.	0	DATE	06/10/2021
SHEET	9	OF	11

13.5 The survey report should also cover the following.

- General site observation such as location of access roads, river and nallah courses, irrigation canals etc.
- Presence of any well and /or tube well in the site and water level in them shall also be indicated.
- Whether there is any rock outcrops in the site.
- Existing drainage pattern of the site, possibility of water logging and high flood level of the area.

13.6 Final survey report shall be submitted in 6 copies of standard A4 size sheets properly bound and printed using good quality paper and material.

#### **14.0 CLEARANCE OF JUNGLES AND CUTTING OF TREES**

Clearance of jungles and cutting of trees as required to facilitate the survey work also form part of the contract. Necessary permission of concerned public bodies shall be secured by the owner. The contractor shall ensure that minimum amount of jungles are cleared and trees are properly cut under the direction of public bodies. The trees and jungles as cleared shall be stacked and handed over to the engineer-in-charge/owner. No extra payment is admissible under this account.

#### **15.0 INSPECTION**

The contractor shall make all arrangements of men, material, instruments, surveyors, necessary records and field data etc at the work site for checking of the work to the satisfaction of the engineer-in-charge or his authorised representative during the progress and on successful completion of the work. The contractor shall intimate well in advance before final decamping from work site so that the final work can be inspected by the engineer-in-charge. This will form a part of acceptance of the work for release of payments.

**TECHNICAL SPECIFICATION  
FOR  
TOPOGRAPHICAL SURVEY OF  
1 X 600 MW METTUR FGD**

SPEC. NO. PE-DC-02-601-C001		
VOLUME IIB		
SECTION D		
REV. NO. 0	DATE 06.10.2021	
SHEET 10	OF	11

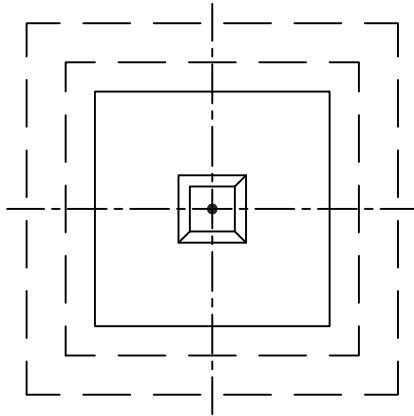

**VIEW 1-1**

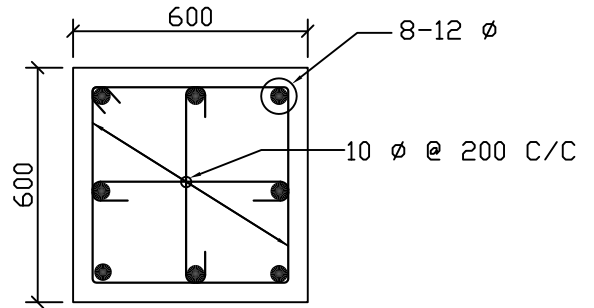

**SECTION 2-2**

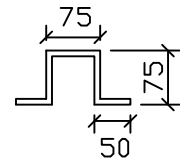

**LUG DETAILS**

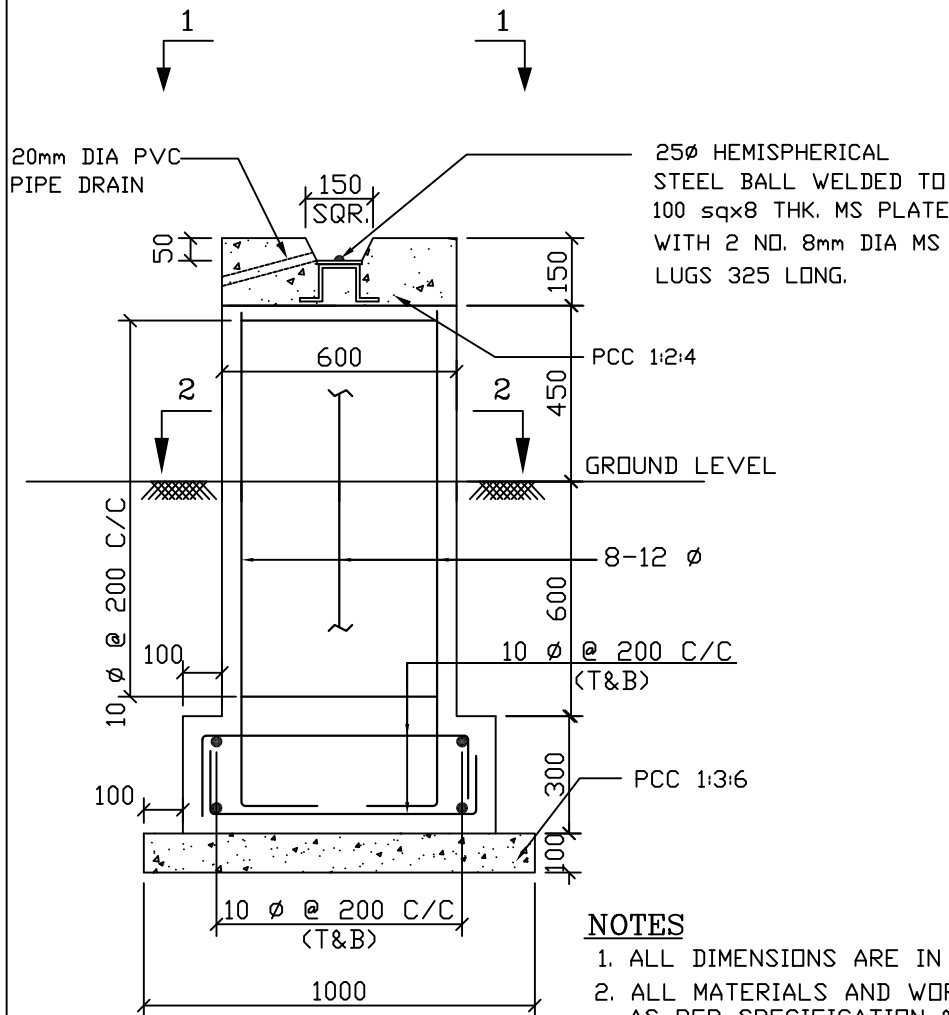

**FIG. 1  
BENCH MARK PILLAR**

**NOTES**

1. ALL DIMENSIONS ARE IN MM
2. ALL MATERIALS AND WORKMANSHIP SHALL BE AS PER SPECIFICATION & RELEVANT IS CODES.
3. GRADE OF CONCRETE SHALL BE M25.
4. REINFORCEMENT STEEL SHALL BE TMT BAR OF Fe500 GRADE.

**TECHNICAL SPECIFICATION  
FOR  
TOPOGRAPHICAL SURVEY OF  
1 X 600 MW METTUR FGD**

SPEC. NO. PE-DC-02-601-C001	
VOLUME IIB	
SECTION D	
REV. NO. 0	DATE 06.10.2021
SHEET 11 OF 11	

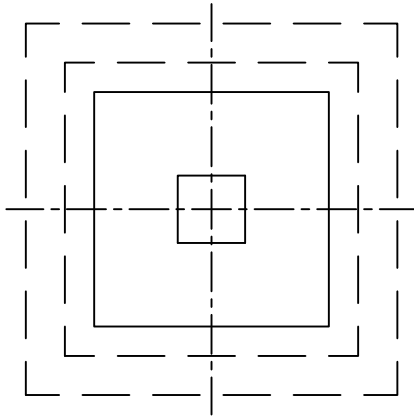

VIEW 3-3

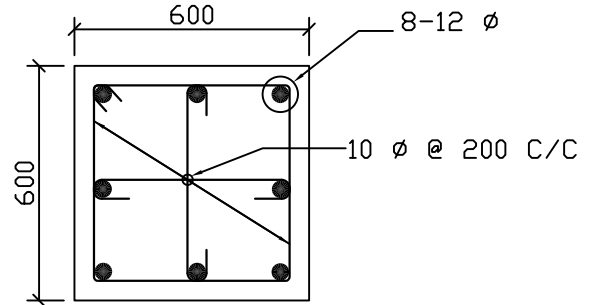

SECTION 4-4

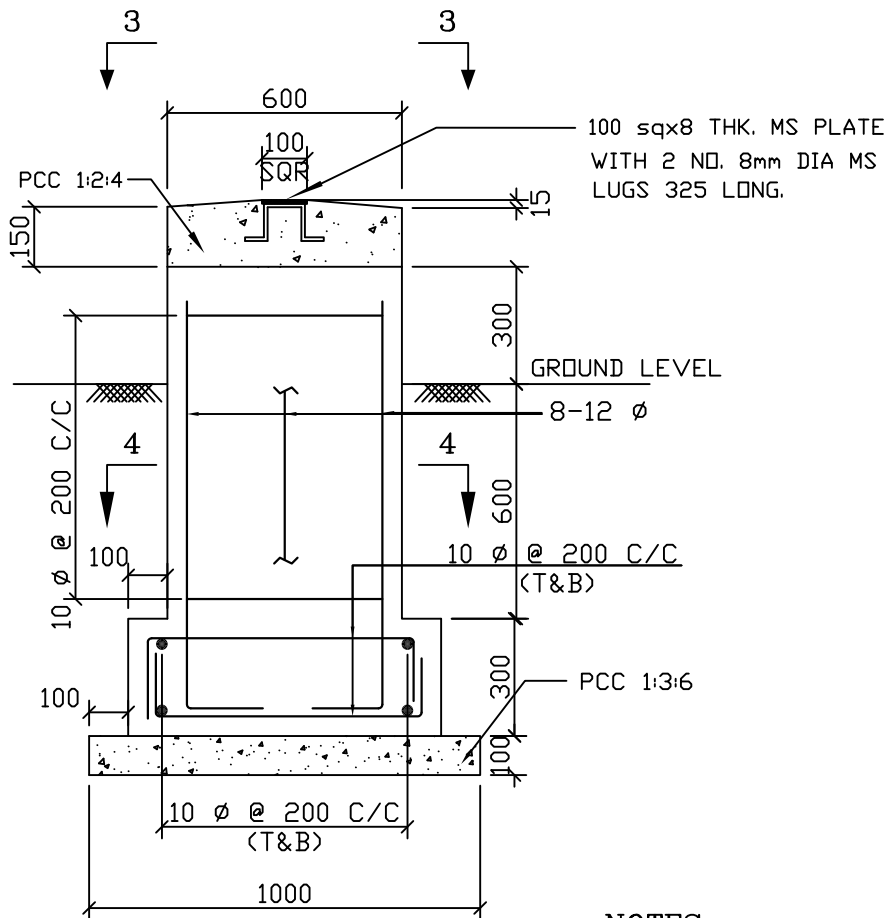
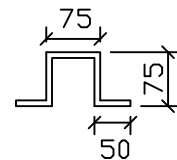

FIG. 2

GRID PILLAR/REFERENCE PILLAR



LUG DETAILS

**NOTES**

1. ALL DIMENSIONS ARE IN MM
2. ALL MATERIALS AND WORKMANSHIP SHALL BE AS PER SPECIFICATION & RELEVANT IS CODES.
3. GRADE OF CONCRETE SHALL BE M25.
4. REINFORCEMENT STEEL SHALL BE TMT BAR OF Fe500 GRADE.

DATE 06.10.2021

PREPARED BY: VV

CHECKED BY: TMS

APPROVED BY: DKM

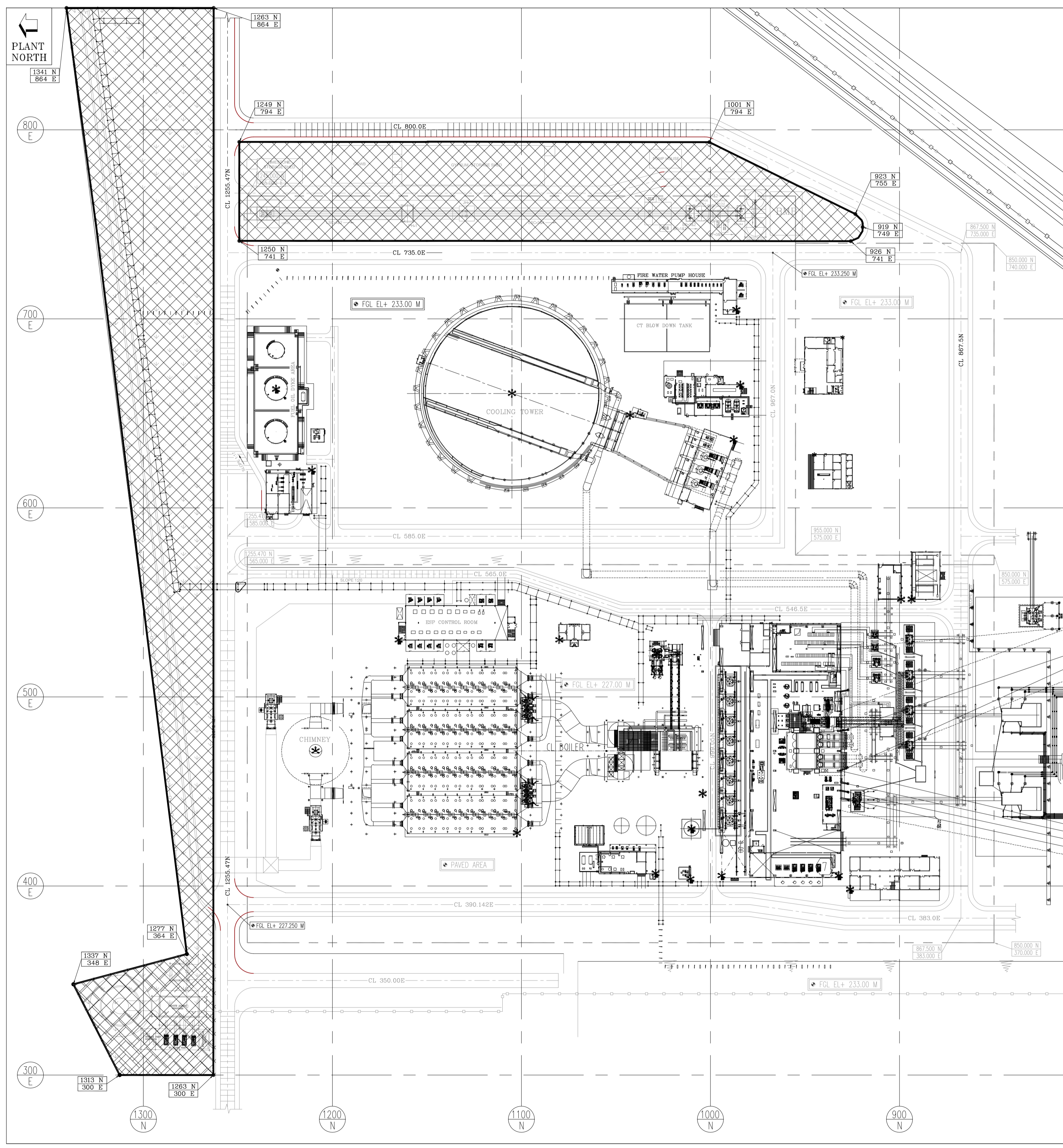

**NOTES:-**

1. AREA MARKED FOR TOPOGRAPHICAL SURVEY IS INDICATIVE ONLY. THE EXACT LOCATION FOR TOPOGRAPHICAL SURVEY SHALL BE FURNISHED DURING EXECUTION.
2. TOPOGRAPHICAL SURVEY SHALL BE CARRIED OUT AS PER SPECIFICATION.

**REFERENCE DRAWING:-**

1. PLOT PLAN

**LEGEND:-**



TENDER PURPOSE ONLY

The information on this document is the property of Bharat Heavy Electricals Limited. It must not be used directly or indirectly in any way detrimental to the interest of the company.

ELECTRONIC FILE NAME:

JOB NO.	O2			
STATUS	PROPOSAL			
DISTRIBUTION				
TO				
NO.				
REV.	DATE	ALTD	CHD	APPD

CUSTOMER:		1x600MW METTUR FGD			
		BHARAT HEAVY ELECTRICALS LTD			
		POWER SECTOR PROJECT ENGINEERING MANAGEMENT NOIDA			
<small>COPY RIGHT AND CONFIDENTIAL</small> <small>The information on this document is the property of</small> <small>BHARAT HEAVY ELECTRICALS LIMITED it must not be used directly or</small> <small>indirectly in any way detrimental to the interest of the company.</small>		DEPT	NAME	SIGN	DATE
NO.	REV.	DATE	ALTD	CHD	APPD

REV.	DATE	ALTD	CHD	APPD	REV.	DATE	ALTD	CHD	APPD	REV.	DATE	ALTD	CHD	APPD
------	------	------	-----	------	------	------	------	-----	------	------	------	------	-----	------

TITLE		TOPOGRAPHICAL SURVEY LAYOUT	
DEPT	SCALE	DRAWING NO	PE-DG-02-601-C001
SIGN	DATE	SHEET	1 OF 1
		REV.	1

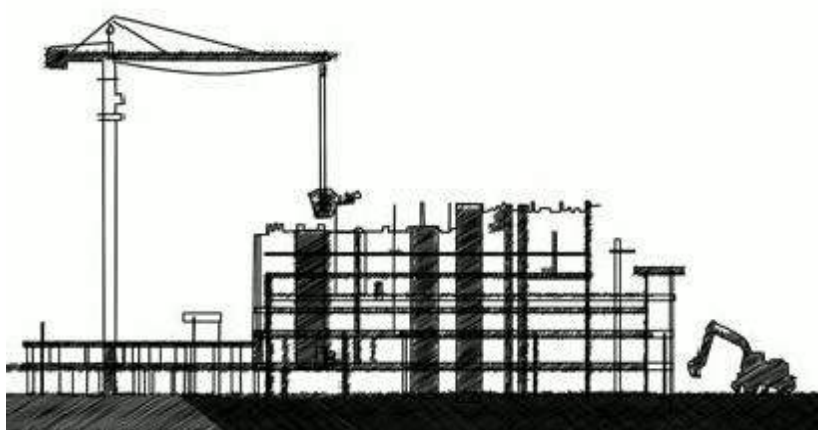

**HEALTH,  
SAFETY and  
ENVIRONMENT  
PLAN**

for

**SITE  
OPERATIONS**

by

**SUB-  
CONTRACTORS**

**POWER SECTOR**

# HSE PLAN FOR SITE OPERATIONS BY BHEL'S SUBCONTRACTORS

## AT A GLANCE

BEFORE START	<b>SIGNING OF MOU</b> Agree to comply to HSE requirement- Statutory and BHEL's	
PLAN	<b>HSE ORGANISATION</b>	
	<b>Manpower</b> <ul style="list-style-type: none"> <li>1 (one) safety officer for every 500 workers or part thereof</li> <li>1(one) safety-steward/ supervisor for every 100 workers</li> </ul> <b>Qualification</b> As per Cl. 7.1	<b>HSE Roles and responsibilities</b> <ul style="list-style-type: none"> <li>Site In-charge- As per clause 7.2.1</li> <li>Safety officer- As per clause 7.2.2</li> </ul>
	<b>HSE Planning</b> for Man, Machinery/Equipment/Tools & Tackles	
PROVIDE	<b>HSE INFRASTRUCTURE</b>	
	<ul style="list-style-type: none"> <li>PPEs</li> <li>Drinking Water</li> <li>Washing Facilities</li> <li>Latrines and Urinals</li> <li>Provision of shelter for rest</li> <li>Medical facilities</li> </ul>	<ul style="list-style-type: none"> <li>Canteen facilities</li> <li>Labour Colony</li> <li>Emergency Vehicle</li> <li>Pest Control</li> <li>Scrapyard</li> <li>Illumination</li> </ul>
TRAIN	<b>HSE TRAINING , AWARENESS &amp; PROMOTION</b>	
	<b>Training</b> <ul style="list-style-type: none"> <li>Induction training</li> <li>Height work and other critical areas</li> <li>Tool Box talk &amp; Pep Talk</li> </ul>	<b>Awareness &amp; Promotion</b> <ul style="list-style-type: none"> <li>Signage</li> <li>Poster</li> <li>Banner</li> <li>Competition</li> <li>Awards</li> </ul>
COMMUNICATE	<b>HSE COMMUNICATION</b>	
	<b>Incident Reporting</b> <ul style="list-style-type: none"> <li>Accident- Fatal &amp; Major</li> <li>Property damage</li> <li>Near Miss</li> </ul>	<b>Event Reporting</b> <ul style="list-style-type: none"> <li>Celebrations</li> <li>Training</li> <li>Medical camp</li> </ul>

**EXECUTE SAFELY**

**OPERATIONAL CONTROL PROCEDURES**

**PERMIT TO WORK**

Height work (above 2 metres), Hot Work, Heavy Lifting, Confined Space, Radiography, excavation (More than 4 metres)

**SAFETY DURING WORK EXECUTION**

- |  |   |
|--|---|
| <ul style="list-style-type: none"> <li>• Welding</li> <li>• Rigging</li> <li>• Cylinder- storage &amp; Movement</li> <li>• Demolition work</li> <li>• T&amp;Ps</li> <li>• Chemical Handling</li> <li>• Electrical works</li> </ul> | <ul style="list-style-type: none"> <li>• Fire</li> <li>• Scaffolding</li> <li>• Height work</li> <li>• Working Platform</li> <li>• Excavation</li> <li>• Ladder</li> <li>• Lifting</li> <li>• Hoisting appliance</li> </ul> |
|--|---|

**HOUSE KEEPING**

**WASTE MANGEMENT**

**TRAFFIC MANAGEMENT**

**ENVIRONMENTAL CONTROL**

**EMERGENCY PREPAREDNESS AND RESPONSE PLAN**

**CHECKS**

**HSE AUDITS & INSPECTION**

- |   |  |
|---|--|
| <ul style="list-style-type: none"> <li>• Daily Checks</li> <li>• Inspection of PPEs</li> <li>• Inspection of T&amp; Ps</li> <li>• Inspection of Cranes &amp; Winches</li> </ul> | <ul style="list-style-type: none"> <li>• Inspection of Height work</li> <li>• Inspection of Welding and Gas cutting</li> <li>• Inspection of elevators etc.</li> </ul> |
|---|--|

**HSE PERFORMANCE EVALUATION PARAMETERS**

**NON CONFORMANCE**

**PENALTY for NON CONFORMANCE**

**Refer Clause 16**

**Incremental penalty**

For repeated violation by the same person, the penalty would be double of the previous penalty

For repeated fatal incident in the same Unit incremental penalty to be imposed. The subcontractor will pay 2 times the penalty compared to previously paid in case there are repeated cases of fatal incidents under the same subcontractor for the same package in the same unit.

	<b>HEALTH, SAFETY AND ENVIRONMENT PLAN FOR SITE OPERATION by SUBCONTRACTORS</b>	Doc no.: HSEP: 14 REV: 01
	POWER SECTOR	Date: 20.01.2020

### REVISION HISTORY SHEET

Date	Revision No.	Details of Changes	Reason	Prepared	Reviewed	Approved
12.08.2014	00	First Issue	First Issue	S. B. Jayant, Dy Manager- FQA & Safety	A. K. Sinha, GM-FQA & Safety	Anuj Bhatnagar, ED-FQA & Safety
20.01.2020	01	Formats added:  <b>HSEP:14-F30 – Monthly HSE Planning &amp; Review</b> (Page 11, Clause 8.0 - updated)  HSEP:14-F13E-Excavation Inspection Format (part of F30) HSEP:14-F32B – Job Safety Analysis Format (part of F30)  <b>HSEP:14-F31A – Daily HSE Reporting</b> (Page 18, Clause 10.3 – added)  <b>HSEP:14-F33 – HSE Performance Evaluation</b> (Page 31, Clause 13 – revised)	IOM No.  <b>PSHQHSE/M ONREP/02</b>  Dated 08-Jan-2020	Rohit Kumar	Santosh Nair, GM (MSX & HSE)	



**HEALTH, SAFETY AND ENVIRONMENT  
PLAN FOR  
SITE OPERATION by SUBCONTRACTORS**

Doc no.: HSEP: 14

REV: 01

Date: 20.01.2020

POWER SECTOR

Page: 1 of 43

Sr. No.	Description	Page No.
1.0	PURPOSE	4
2.0	SCOPE	4
3.0	OBJECTIVES AND TARGETS	4
4.0	HEALTH, SAFETY & ENVIRONMENT POLICY	5
5.0	MEMORANDUM OF UNDERSTANDING	6
6.0	TERMS & DEFINITIONS	7
7.0	HSE ORGANIZATION	8
7.1	QUALIFICATION FOR HSE PERSONNEL	8
7.2	RESPONSIBILITIES	9
8.0	PLANNING BY SUBCONTRACTOR	11
8.1	MOBILISATION OF MACHINERY/EQUIPMENT/TOOLS	11
8.2	MOBILISATION OF MANPOWER BY SUBCONTRACTOR	11
8.3	PROVISION OF PPEs	12
8.4	ARRANGEMENT OF INFRASTRUCTURE	13
9.0	HSE TRAINING & AWARENESS	16
9.1	HSE INDUCTION TRAINING	16
9.2	HSE TOOLBOX TALK	17
9.3	TRAINING ON HEIGHT WORK	17
9.4	HSE TRAINING DURING PROJECT EXECUTION	17



**HEALTH, SAFETY AND ENVIRONMENT  
PLAN FOR  
SITE OPERATION by SUBCONTRACTORS**

Doc no.: HSEP: 14

REV: 01

Date: 20.01.2020

POWER SECTOR

Page: 2 of 43

9.5	HSE PROMOTION-SIGNAGE, POSTERS, COMPETITION, AWARDS ETC	18
10.0	HSE COMMUNICATION	18
10.1	INCIDENT REPORTING	18
10.2	HSE EVENT REPORTING	18
11.0	OPERATIONAL CONTROL	19
11.1	HSE ACTIVITIES	19
11.2	WORK PERMIT SYSTEM	20
11.3	SAFETY DURING WORK EXECUTION	20
11.4	ENVIRONMENTAL CONTROL	24
11.5	HOUSEKEEPING	24
11.6	WASTE MANAGEMENT	25
11.7	TRAFFIC MANAGEMENT SYSTEM	26
11.8	EMERGENCY PREPAREDNESS AND RESPONSE	28
12.0	HSE INSPECTION	29
12.1	DAILY HSE CHECKS	29
12.2	INSPECTION OF PPE	29
12.3	INSPECTION OF T&Ps	30
12.4	INSPECTION OF CRANES AND WINCHES	30
12.5	INSPECTION ON HEIGHT WORKING	30
12.6	INSPECTION ON WELDING AND GAS CUTTING OPERATION	30



**HEALTH, SAFETY AND ENVIRONMENT  
PLAN FOR  
SITE OPERATION by SUBCONTRACTORS**

Doc no.: HSEP: 14

REV: 01

Date: 20.01.2020

POWER SECTOR

Page: 3 of 43

12.7	INSPECTION ON ELECTRICAL INSTALLATION / APPLIANCES	31
12.8	INSPECTION OF ELEVATOR	31
12.9	INSPECTION OF EXCAVATION ACTIVITIES	31
13.0	HSE PERFORMANCE	31
14.0	HSE PENALTIES	32
15.0	OTHER REQUIREMENTS	32
16.0	NON COMPLIANCE	33
17.0	HSE AUDIT/INSPECTION	34
18.0	MONTHLY HSE REVIEW MEETING	34
19.0	FORMATS USED	34
20.0	Annexures	36



**HEALTH, SAFETY AND ENVIRONMENT  
PLAN FOR  
SITE OPERATION by SUBCONTRACTORS**

Doc no.: HSEP: 14

REV: 01

POWER SECTOR

Date: 20.01.2020

Page: 4 of 43

## 1.0 PURPOSE

- 1.1 The purpose of this HSE Plan is to provide for the systematic identification, evaluation, prevention and control of general workplace hazards, specific job hazards, potential hazards and environmental impacts that may arise from foreseeable conditions during installation and servicing of industrial projects and power plants.
- 1.2 This document shall be followed by BHEL's subcontractors at all installation and servicing sites. In case customer specific documents are to be implemented, this document will be followed in conjunction with customer specific documents.
- 1.3 Although every effort has been made to make the procedures and guidelines in line with statutory requirements, in case of any discrepancy relevant statutory guidelines must be followed.
- 1.4 In case the customer has any specific requirement, the same is to be fulfilled.

## 2.0 SCOPE

The document is applicable for BHEL's Subcontractors at all installation / servicing activities of BHEL Power Sector as per the relevant contractual obligations.

## 3.0 OBJECTIVES AND TARGETS

The HSE Plan reflects that BHEL places high priority upon the Occupational Health, Safety and Environment at workplaces.

- Ensure the Health and Safety of all persons at work site is not adversely affected by the work.
- Ensure protection of environment of the work site.
- Comply at all times with the relevant statutory and contractual HSE requirements.
- Provide trained, experienced and competent personnel. Ensure medically fit personnel only are engaged at work.
- Provide and maintain plant, places and systems of work that are safe and without risk to health and the environment.
- Provide all personnel with adequate information, instruction, training and supervision on the safety aspect of their work.
- Effectively control, co-ordinate and monitor the activities of all personnel on the Project sites including subcontractors in respects of HSE.
- Establish effective communication on HSE matters with all relevant parties involved in the Project works.
- Ensure that all work planning takes into account all persons that may be affected by the work.
- Ensure fitness testing of all T&Ps/Lifting appliances like cranes, chain pulley blocks etc. are to be certified by competent person.
- Ensure timely provision of resources to facilitate effective implementation of HSE requirements.
- Ensure continual improvements in HSE performance
- Ensure conservation of resources and reduction of wastage.
- Capture the data of all incidents including near misses, process deviation etc. Investigate and analyze the same to find out the root cause.
- Ensure timely implementation of correction, corrective action and preventive action.



**HEALTH, SAFETY AND ENVIRONMENT  
PLAN FOR  
SITE OPERATION by SUBCONTRACTORS**

Doc no.: HSEP: 14

REV: 01

Date: 20.01.2020

POWER SECTOR

Page: 5 of 43

**HSE TARGETS**

EXPLOSION	ZERO
FATALITY	ZERO
LOST TIME INJURY	ZERO
FIRE	ZERO
VEHICLE INCIDENTS	ZERO
ENVIRONMENTAL INCIDENTS	ZERO

**4.0 BHEL POWER SECTOR HEALTH, SAFETY & ENVIRONMENT POLICY**

**Health, Safety & Environment Policy of BHEL**

In BHEL, Health, Safety and Environment (HSE) responsibilities are driven by our commitment to protect our employees and people we work with, community and environment. BHEL believes in zero tolerance for unsafe work/non-conformance to safety and in minimizing environmental footprint associated with all its business activities. We commit to continually improve our HSE performance by:

- Developing safety and sustainability culture through active leadership and by ensuring availability of required resources.
- Ensuring compliance with applicable legislation, regulations and BHEL systems.
- Taking up activities for conservation of resources and adopting sound waste management by following Reduce/Recycle/Reuse approach.
- Continually identifying, assessing and managing environmental impacts and Occupational Health & Safety risks of all activities, products and services adopting approach based on elimination/substitution/reduction/control.
- Incorporating appropriate Occupational Health, Safety and Environment criteria into business decisions, design of products & systems and for selection of plants, technologies and services.
- Imparting appropriate structured training to all persons at workplace and promoting awareness amongst customers, contractors and suppliers on HSE issues.
- Reviewing periodically this policy and HSE Management Systems to ensure its relevance, appropriateness and effectiveness.
- Communicating this policy within BHEL and making it available to interested parties.

sd/-

**CMD, BHEL**



**HEALTH, SAFETY AND ENVIRONMENT  
PLAN FOR  
SITE OPERATION by SUBCONTRACTORS**

Doc no.: HSEP: 14

REV: 01

POWER SECTOR

Date: 20.01.2020

Page: 6 of 43

**5.0 MEMORANDUM OF UNDERSTANDING:**

After award of work, subcontractors are required to enter into a memorandum of understanding as given below:

**Memorandum of Understanding**

BHEL, Power Sector \_\_\_\_\_ Region is committed to Health, Safety and Environment Policy (HSE Policy).

M/s \_\_\_\_\_ do hereby also commit to comply with the same HSE Policy while executing the Contract Number \_\_\_\_\_

M/s \_\_\_\_\_ shall ensure that safe work practices as per the HSE plan. Spirit and content therein shall be reached to all workers and supervisors for compliance.

In addition to this, M/S \_\_\_\_\_ shall comply to all applicable statutory and regulatory requirements which are in force in the place of project and any special requirement specified in the contract document of the principal customer.

M/s \_\_\_\_\_ shall co-operate in HSE audits/inspections conducted by BHEL /customer/ third party and ensure to close any non-conformity observed/reported within prescribed time limit.

Signed by authorized representative of M/s -----

Name :

Place & Date:



**HEALTH, SAFETY AND ENVIRONMENT  
PLAN FOR  
SITE OPERATION by SUBCONTRACTORS**

Doc no.: HSEP: 14

REV: 01

POWER SECTOR

Date: 20.01.2020

Page: 7 of 43

## 6.0 TERMS AND DEFINITIONS

### 6.1 DEFINITIONS

#### 6.1.1 INCIDENT

Work- related or natural event(s) in which an injury, or ill health (regardless of severity), damage to property or fatality occurred, or could have occurred.

#### 6.1.2 NEAR MISS

An incident where no ill health, injury, damage or other loss occurs, but it had a potential to cause, is referred to as "Near-Miss".

#### 6.1.3 MAN-HOURS WORKED

The total number of man hours worked by all employees including subcontractors working in the premises. It includes managerial, supervisory, professional, technical, clerical and other workers including contract labours. Man-hours worked shall be calculated from the payroll or time clock recorded including overtime. When this is not feasible, the same shall be estimated by multiplying the total man-days worked for the period covered by the number of hours worked per day. The total number of workdays for a period is the sum of the number of men at work on each day of period. If the daily hours vary from department to department separate estimate shall be made for each department and the result added together.

#### 6.1.4 FIRST AID CASES

First aids are not essentially all reportable cases, where the injured person is given medical treatment and discharged immediately for reporting on duty, without counting any lost time.

#### 6.1.5 LOST TIME INJURY

Any work injury which renders the injured person unable to perform his regular job or an alternative restricted work assignment on the next scheduled work day after the day on which the injury occurred.

#### 6.1.6 MEDICAL CASES

Medical cases come under non-reportable cases, where owing to illness or other reason the employee was absent from work and seeks Medical treatment.

#### 6.1.7 TYPE OF INCIDENTS & THEIR REPORTING:

The three categories of Incident are as follows:

##### **Non-Reportable Cases:**

An incident, where the injured person is given medical help and discharged for work without counting any lost time.



**HEALTH, SAFETY AND ENVIRONMENT  
PLAN FOR  
SITE OPERATION by SUBCONTRACTORS**

Doc no.: HSEP: 14

REV: 01

POWER SECTOR

Date: 20.01.2020

Page: 8 of 43

**Reportable Cases:**

In this case the injured person is disable for 48 hours or more and is not able to perform his duty.

**Injury Cases:**

These are covered under the heading of non-reportable cases. In these cases the incident caused injury to the person, but he still continues his duty.

**6.1.8 TOTAL REPORTABLE FREQUENCY RATE**

Frequency rate is the number of Reportable Lost Time Injury (LTI) per one Million Man hours worked. Mathematically, the formula read as:

$$\frac{\text{Number of Reportable LTI} \times 1,000,000}{\text{Total Man Hours Worked}}$$

**6.1.9 SEVERITY RATE**

Severity rate is the Number of days lost due to Lost Time Injury (LTI) per one Million Man hours worked. Mathematically, the formula reads as:

$$\frac{\text{Days lost due to LTI} \times 1,000,000}{\text{Total Man Hours Worked}}$$

**6.1.10 INCIDENCE RATE**

Incidence Rate is the Number of LTI per one thousand manpower deployed. Mathematically, the formula reads as:

$$\frac{\text{Number of LTI} \times 1000}{\text{Average number of manpower deployed}}$$

**7.0 HSE ORGANISATION**

**Number of safety officers:**

The subcontractor must deploy one safety officer for every 500 workers or part thereof in each package. In addition, there must be one safety-steward/safety-supervisor for every 100 workers.

**Deployment:** The subcontractor should deploy sufficient safety officers and safety-steward/Safety-supervisor, as per requirement given above, since initial stage and add more in proportion to the added strength in work force. Any delay in deployment will attract a penalty of Rs.30,000/- per man month for the delayed period.

**7.1 QUALIFICATION FOR HSE PERSONNEL**

Sl.no	Designation	Qualification	Experience
1	Safety officer (Construction Agency)	Degree or Diploma in Engineering with full time diploma in Industrial Safety with construction safety as one of the subjects	Minimum two years for degree holder and five years for diploma holder in the field of Construction of power plant/ major industries



**HEALTH, SAFETY AND ENVIRONMENT  
PLAN FOR  
SITE OPERATION by SUBCONTRACTORS**

Doc no.: HSEP: 14

REV: 01

POWER SECTOR

Date: 20.01.2020

Page: 9 of 43

2	Safety-Steward/ Supervisor	Safety- Supervisor	Degree or diploma in any discipline with full time diploma in Industrial Safety with construction safety as one of the subjects	Minimum two years
---	-------------------------------	-----------------------	---	-------------------

## 7.2 RESPONSIBILITIES

### 7.2.1 SITE IN -CHARGE OF SUBCONTRACTOR

- Shall sign Memorandum of Understanding (MoU) for compliance to BHEL's HSE Plan for Site Operations as per clause 5.0
- Shall engage qualified safety officer(s) and steward (s) as per clause 7.0
- Shall adhere to the rules and regulations mentioned in this code, practice very strictly in his area of work in consultation with his concerned engineer and the safety coordinator.
- Shall screen all workmen for health and competence requirement before engaging for the job and periodically thereafter as required.
- Shall not engage any employee below 18 years.
- Shall arrange for all necessary PPEs like safety helmets, belts, full body harness, shoes, face shield, hand gloves etc. before starting the job. Shall ensure that no working men/women carry excessive weight more than stipulated in Factory Rule Regulation R57.
- Shall ensure that all T&Ps engaged are tested for fitness and have valid certificates from competent person.
- Shall ensure that provisions stipulated in contract Labour Regulation Act 1970, Chapter V C.9, canteen, rest rooms/washing facilities to contracted employees at site.
- Shall adhere to the instructions laid down in Operation Control Procedures (OCPs) available with the site management.
- Shall ensure that person working above 2.0 meter should use Safety Harness tied to a life line/stable structure.
- Shall ensure that materials are not thrown from height. Cautions to be exercised to prevent fall of material from height.
- Shall report all incidents (Fatal/Major/Minor/Near Miss) to the Site engineer /HSE officer of BHEL.
- Shall ensure that Horseplay is strictly forbidden.
- Shall ensure that adequate illumination is arranged during night work.
- Shall ensure that all personnel working under subcontractor are working safely and do not create any Hazard to self and to others.
- Shall ensure display of adequate signage/posters on HSE.
- Shall ensure that mobile phone is not used by workers while working.
- Shall ensure conductance of HSE audit, mockdrill, medical camps, induction training and training on HSE at site.
- Shall ensure full co-operation during HQ/External /Customer HSE audits.



**HEALTH, SAFETY AND ENVIRONMENT  
PLAN FOR  
SITE OPERATION by SUBCONTRACTORS**

Doc no.: HSEP: 14

REV: 01

Date: 20.01.2020

POWER SECTOR

Page: 10 of 43

- Shall ensure submission of look-ahead plan for procurement of HSE equipment's and PPEs as per work schedule.
- Shall ensure good housekeeping.
- Shall ensure adequate valid fire extinguishers are provided at the worksite.
- Shall ensure availability of sufficient number of toilets /restrooms and adequate drinking water at work site and labour colony.
- Shall ensure adequate emergency preparedness.
- Shall be member of site HSE committee and attend all meetings of the committee
- Power source for hand lamps shall be maximum of 24 v.
- Temporary fencing should be done for open edges if Hand – railings and Toe-guards are not available.

#### **7.2.2 HEALTH, SAFETY AND ENVIRONMENT OFFICER OF SUBCONTRACTOR**

- Carry out safety inspection of Work Area, Work Method, Men, Machine & Material, P&M and other tools and tackles.
- Facilitate inclusion of safety elements into Work Method Statement.
- Highlight the requirements of safety through Tool-box / other meetings.
- Help concerned HOS to prepare Job Specific instructions for critical jobs.
- Conduct investigation of all incident/dangerous occurrences & recommend appropriate safety measures.
- Advice & co-ordinate for implementation of HSE permit systems, OCPs & MPs.
- Convene HSE meeting & minute the proceeding for circulation & follow-up action.
- Plan procurement of PPE & Safety devices and inspect their healthiness.
- Report to PS Region/HQ on all matters pertaining to status of safety and promotional program at site level.
- Facilitate administration of First Aid
- Facilitate screening of workmen and safety induction.
- Conduct fire Drill and facilitate emergency preparedness
- Design campaigns, competitions & other special emphasis programs to promote safety in the workplace.
- Apprise PS– Region on safety related problems.
- Notify site personnel non-conformance to safety norms observed during site visits / site inspections.
- Recommend to Site In charge, immediate discontinuance of work until rectification, of such situations warranting immediate action in view of imminent danger to life or property or environment.
- To decline acceptance of such PPE / safety equipment that do not conform to specified requirements.
- Encourage raising Near Miss Report on safety along with, improvement initiatives on safety.
- Shall work as interface between various agencies such customer, package-in-charges, subcontractors on HSE matters



**HEALTH, SAFETY AND ENVIRONMENT  
PLAN FOR  
SITE OPERATION by SUBCONTRACTORS**

Doc no.: HSEP: 14

REV: 01

POWER SECTOR

Date: 20.01.2020

Page: 11 of 43

#### 8.0 PLANNING BY SUBCONTRACTOR

Monthly planning and review of HSE activities shall be carried out by subcontractor as per format No. HSEP:14-F30 jointly along with BHEL.

#### 8.1 MOBILISATION OF MACHINERY/EQUIPMENT/TOOLS BY SUBCONTRACTOR

- As a measure to ensure that machinery, equipment and tools being mobilized to the construction site are fit for purpose and are maintained in safe operating condition and complies with legislative and owner requirement, inspection shall be arranged by in-house competent authority for acceptance as applicable.
- The machinery and equipment to be embraced for this purpose shall include but not limited to the following:
  - Mobile cranes.
  - Side Booms.
  - Forklifts.
  - Grinding machine.
  - Drilling machine.
  - Air compressors.
  - Welding machine.
  - Generator sets.
  - Dump Trucks.
  - Excavators.
  - Dozers
  - Grit Blasting Equipment.
  - Hand tools.
- Subcontractor shall notify the engineer, of his intention to bring on to site any equipment or any container, with liquid or gaseous fuel or other substance which may create a hazard. The Engineer shall have the right to prescribe the condition under which such equipment or container may be handled and used during the performance of the works and the subcontractor shall strictly adhere to such instructions. The Engineer shall have the right to inspect any construction tool and to forbid its use, if in his opinion it is unsafe. No claim due to such prohibition will be entertained.

#### 8.2 MOBILISATION OF MANPOWER BY SUBCONTRACTOR

- The subcontractor shall arrange induction and regular health check of their employees as per schedule VII of BOCW rules by a registered medical practitioner.
- The subcontractor shall take special care of the employees affected with occupational diseases under rule 230 and schedule II of BOCW Rules. The employees not meeting the fitness requirement should not be engaged for such job.
- Ensure that the regulatory requirements of excessive weight limit (to carry/lift/ move weights beyond prescribed limits) for male and female workers are complied with.
- Appropriate accommodation to be arranged for all workmen in hygienic condition.



**HEALTH, SAFETY AND ENVIRONMENT  
PLAN FOR  
SITE OPERATION by SUBCONTRACTORS**

Doc no.: HSEP: 14

REV: 01

POWER SECTOR

Date: 20.01.2020

Page: 12 of 43

**8.3 PROVISION OF PPEs**

- Personnel Protective Equipment (PPEs), in adequate numbers, will be made available at site & their regular use by all concerned will be ensured
- The following matrix recommends usage of minimum PPEs against the respective job.

Sl. No	Type of work	PPEs
1	Concrete and asphalt mixing	Nose mask, hand glove, apron and gum boot
2	Welders/Grinders/ Gas cutters	Welding/face screen, apron, hand gloves, nose mask and ear muffs if noise level exceeds 90dB. Helmet fitted with welding shield is preferred for welders
3	Stone/ concrete breakers	Ear muffs, safety goggles, hand gloves
4	Electrical Work	Rubber hand glove, Electrical Resistance shoes
5	Insulation Work	Respiratory mask, Hand gloves, safety goggles
6	Work at height	Double lanyard full body harness, Fall arrestor (specific cases)
7	Grit/Sand blasting	Blast suit, blast helmet, respirator, leather gloves
8	Painting	Plastic gloves, Respirators (particularly for spray painting)
9	Radiography	As per BARC guidelines

- The PPEs shall conform to the relevant standards as below and bear ISI mark.

**Relevant is-codes for personal protection**

IS: 2925 – 1984	Industrial Safety Helmets.
IS: 4770 – 1968	Rubber gloves for electrical purposes.
IS: 6994 – 1973 (Part-I)	Industrial Safety Gloves (Leather & Cotton Gloves).
IS: 1989 – 1986 (Part-I-II)	Leather safety boots and shoes.
IS: 5557 – 1969	Industrial and Safety rubber knee boots.
IS: 6519 – 1971	Code of practice for selections care and repair of Safety footwear.
IS: 11226 – 1985	Leather Safety footwear having direct molding sole.
IS: 5983 – 1978	Eye protectors.
IS: 9167 – 1979	Ear protectors.
IS: 1179-1967	Eye & Face protection during welding
IS: 3521 – 1983	Industrial Safety Belts and Harness
IS: 8519 -1977	Guide for selection of industrial Safety equipment for body protection
IS: 9473-2002, 14166-1994, 14746-1999	Respiratory Protective Devices

The list is not exhaustive. The safety officer may demand additional PPEs based on specific requirement.



**HEALTH, SAFETY AND ENVIRONMENT  
PLAN FOR  
SITE OPERATION by SUBCONTRACTORS**

Doc no.: HSEP: 14

REV: 01

Date: 20.01.2020

POWER SECTOR

Page: 13 of 43

- Where workers are employed in sewers and manholes, which are in use, the subcontractor shall ensure that the manhole covers are opened and ventilated at least for an hour before the workers are allowed to get into manhole, and the manholes so opened shall be cordoned off with suitable railing and provided with warning signals or boards to prevent incident to the public
- Besides the PPEs mentioned above, the persons shall use helmet and safety shoe. The visitors shall use Helmet and any other PPEs as deemed appropriate for the area of work.

Colour scheme for Helmets:

1. Workmen: Yellow
  2. Safety staff: Green or white with green band
  3. Electrician: Red
  4. Others including visitors: White
- All the PPEs shall be checked for its quality before issue and the same shall be periodically checked. The users shall be advised to check the PPEs themselves for any defect before putting on. The defective ones shall be repaired/ replaced.
  - The issuing agency shall maintain register for issue and receipt of PPEs.
  - The Helmets shall have logo or name (abbreviation of agency name permitted) affixed or printed on the front.
  - The body harnesses shall be serial numbered.

#### **8.4 ARRANGEMENT OF INFRASTRUCTURE**

##### **8.4.1 DRINKING WATER**

- Drinking water shall be provided and maintained at suitable places at different elevations.
- Container should be labeled as " Drinking Water"
- Cleaning of the storage tank shall be ensured atleast once in 3 months indicating date of cleaning and next due date.
- Potability of water should be tested as per IS10500 at least once in a year.

##### **8.4.2 WASHING FACILITIES**

- In every workplace, adequate and suitable facilities for washing shall be provided and maintained.
- Separate and adequate cleaning facilities shall be provided for the use of male and female workers. Such facilities shall be conveniently accessible and shall be kept in clean and hygienic condition and dully illuminated for night use.
- Overalls shall be supplied by the subcontractor to the workmen and adequate facilities shall be provided to enable the painters and other workers to wash during the cessation of work.

##### **8.4.3 LATRINES AND URINALS**

- Latrines and urinals shall be provided in every work place.
- Urinals shall also be provided at different elevations.
- They shall be adequately lighted and shall be maintained in a clean and sanitary condition at all times, by appointing designated person.
- Separate facilities shall be provided for the use of male and female worker if any.



**HEALTH, SAFETY AND ENVIRONMENT  
PLAN FOR  
SITE OPERATION by SUBCONTRACTORS**

Doc no.: HSEP: 14

REV: 01

POWER SECTOR

Date: 20.01.2020

Page: 14 of 43

#### 8.4.4 PROVISION OF SHELTER DURING REST

Proper Shed & Shelter shall be provided for rest during break

#### 8.4.5 MEDICAL FACILITIES

##### 8.4.5.1 MEDICAL CENTRE (As per Schedule V, X and XI of BOCW central Rules, 1998)

- A medical centre shall be ensured/identified at site with basic facilities for handling medical emergencies. The medical center can be jointly developed on proportionate sharing basis with permission from BHEL
- A qualified medical professional, not less than MBBS, shall be deployed at the medical centre
- The medical centre shall be equipped with one ambulance, with trained driver and oxygen cylinder.
- Medical waste shall be disposed as per prevailing legislation (Bio-Medical Waste –Management and Handling Rules, 1998)

##### 8.4.5.2 FIRST AIDER

- Ensure availability of Qualified First-aider throughout the working hours.
- Every injury shall be treated, recorded and reported.
- Refresher course on first aid shall be conducted as necessary.
- List of Qualified first aiders and their contact numbers should be displayed at conspicuous places.

##### 8.4.5.3 FIRST AID BOX (as per schedule III of BOCW)

- The subcontractor shall provide necessary first aid facilities as per schedule III of BOCW. At every work place first aid facilities shall be provided and maintained.
- The first aid box shall be kept by first aider who shall always be readily available during the working hours of the work place. His name and contact no to be displayed on the box.
- The first aid boxes should be placed at various elevations so as to make them available within the reach and at the quickest possible time.
- The first aid box shall be distinctly marked with a Green Cross on white background.
- Details of contents of first aid box is given in Annexure No. 01
- Monthly inspection of First Aid Box shall be carried out by the owner as per format no. HSEP:14-F01
- The subcontractor should conduct periodical first –aid classes to keep his supervisor and Engineers properly trained for attending to any emergency.

##### 8.4.5.4 HEALTH CHECK UP (As per schedule VII and Form XI)

The persons engaged at the site shall undergo health checkup as per the format no. HSEP:14-F02 before induction. The persons engaged in the following works shall undergo health checkup at least once in a year:

- a. Height workers
- b. Drivers/crane operators/riggers



**HEALTH, SAFETY AND ENVIRONMENT  
PLAN FOR  
SITE OPERATION by SUBCONTRACTORS**

Doc no.: HSEP: 14

REV: 01

Date: 20.01.2020

POWER SECTOR

Page: 15 of 43

- c. Confined space workers
- d. Shot/sand blaster
- e. Welding and NDE personnel

#### **8.4.6 PROVISION OF CANTEEN FACILITY**

- Canteen facilities shall be provided for the workmen of the project inside the project site.
- Proper cleaning and hygienic condition shall be maintained.
- Proper care should be taken to prevent biological contamination.
- Adequate drinking water should be available at canteen.
- Fire extinguisher shall be provided inside canteen.
- Regular health check-up and medication to the canteen workers shall be ensured.

#### **8.4.7 PROVISION OF ACCOMODATION/LABOUR COLONY**

- The subcontractor shall arrange for the accommodation of workmen at nearby localities or by making a labour colony.
- Regular housekeeping of the labour colony shall be ensured.
- Proper sanitation and hygienic conditions to be maintained.
- Drinking water and electricity to be provided at the labour colony.
- Bathing/ washing bay
- Room ventilation and electrification.

#### **8.4.8 PROVISION OF EMERGENCY VEHICLE**

- Dedicated emergency vehicle shall be made available at workplace by each subcontractor to handle any emergency

#### **8.4.9 PEST CONTROL**

Regular pest control should be carried out at all offices, mainly laboratories, canteen, labour colony and stores.

#### **8.4.10 SCRAPYARD**

- In consultation with customer, scrapyard shall be developed to store metal scrap, wooden scrap, waste, hazardous waste.
- Scrap/Waste shall be segregated as Bio-degradable and non-bio-degradable and stored separately.

#### **8.4.11 ILLUMINATION**

- The subcontractor shall arrange at his cost adequate lighting facilities e.g. flood lighting, hand lamps, area lighting etc. at various levels for safe and proper working operations at dark places and during night hours at the work spot as well as at the pre-assembly area.
- Adequate and suitable light shall be provided at all work places & their approaches including passage ways as per IS: 3646 (Part-II). Some recommended values are given below:



**HEALTH, SAFETY AND ENVIRONMENT  
PLAN FOR  
SITE OPERATION by SUBCONTRACTORS**

Doc no.: HSEP: 14

REV: 01

**POWER SECTOR**

Date: 20.01.2020

Page: **16 of 43**

S. No.	Location	Illumination (Lux)
<b>A. Construction Area</b>		
1.	Outdoor areas like store yards, entrance and exit roads	20
2.	Platforms	50
3.	Entrances, corridors and stairs	100
4.	General illumination of work area	150
5.	Rough work like fabrication, assembly of major items	150
6.	Medium work like assembly of small machined parts rough measurements etc.	300
7.	Fine work like precision assembly, precision measurements etc.	700
8.	Sheet metal works	200
9.	Electrical and instrument labs	450
<b>B. Office</b>		
1.	Outdoor area like entrance and exit roads	20
2.	Entrance halls	150
3.	Corridors and lift cars	70
4.	Lift landing	150
5.	Stairs	100
6.	Office rooms, conference rooms, library reading tables	300
7.	Drawing table	450
8.	Manual telephone exchange	200

- Lamp (hand held) shall not be powered by mains supply but either by 24V or dry cells.
- Lamps shall be protected by suitable guards where necessary to prevent danger, in case of breakage of lamp.
- Emergency lighting provision for night work shall be made to minimise danger in case of main supply failure.

If the subcontractor fails to take appropriate safety precautions or to provide necessary safety devices and equipment or to carry out instructions issued by the authorized BHEL official, BHEL shall have the right to take corrective steps at the risk and cost of the subcontractor

## **9.0 HSE TRAINING & AWARENESS**

### **9.1 HSE INDUCTION TRAINING**

All persons entering into project site shall be given HSE induction training by the HSE officer of BHEL /subcontractor before being assigned to work.

In-house induction training subjects shall include but not limited to:

- Briefing of the Project details.
- Safety objectives and targets.
- Site HSE rules.
- Site HSE hazards and aspects.
- First aid facility.
- Emergency Contact No.
- Incident reporting.
- Fire prevention and emergency response.
- Rules to be followed in the labour colony (if applicable)



**HEALTH, SAFETY AND ENVIRONMENT  
PLAN FOR  
SITE OPERATION by SUBCONTRACTORS**

Doc no.: HSEP: 14

REV: 01

POWER SECTOR

Date: 20.01.2020

Page: 17 of 43

- Proper safety wear & gear must be issued to all the workers being registered for the induction (i.e., Shoes/Helmets/Goggles/Leg guard/Apron etc.)
- They must arrive fully dressed in safety wear & gear to attend the induction.
- Any one failing to conform to this safety wear& gear requirement shall not qualify to attend.
- On completing attending subcontractor's in-house HSE induction, each employee shall sign an induction training form (format no. HSEP:14-F03) to declare that he had understood the content and shall abide to follow and comply with safe work practices. They may only then be qualified to be issued with a personal I.D. card, for access to the work site.

## 9.2 HSE TOOLBOX TALK

- HSE tool Box talk shall be conducted by frontline foreman/supervisor of subcontractor to specific work groups prior to the start of work. The agenda shall consist of the followings:
  - Details of the job being intended for immediate execution.
  - The relevant hazards and risks involved in executing the job and their control and mitigating measures.
  - Specific site condition to be considered while executing the job like high temperature, humidity, unfavorable weather etc.
  - Recent non-compliances observed.
  - Appreciation of good work done by any person.
  - Any doubt clearing session at the end.
- Record of Tool box talk shall be maintained as per format no. HSEP:14-F04
- Tool box talk to be conducted at least once a week for the specific work.

## 9.3 TRAINING ON HEIGHT WORK

Training on height work shall be imparted to all workers working at height by in-house/external faculty at least twice in a year. The training shall include following topics:

- Use of PPEs
- Use of fall arrester, retractable fall arrester, life line, safety nets etc.
- Safe climbing through monkey ladders.
- Inspection of PPEs.
- Medical fitness requirements.
- Mock drill on rescue at height.
- Dos & Don'ts during height work.

## 9.4 HSE TRAINING DURING PROJECT EXECUTION

- Other HSE training shall be arranged by BHEL/ subcontractor as per the need of the project execution and recommendation of HSE committee of site.
- The topics of the HSE training shall be as follows but not limited to:
  - Hazards identification and risk analysis (HIRA)
  - Work Permit System
  - Incident investigation and reporting
  - Fire fighting
  - First aid
  - Fire-warden training
  - EMS and OHSMS
  - T & Ps fitness and operation



**HEALTH, SAFETY AND ENVIRONMENT  
PLAN FOR  
SITE OPERATION by SUBCONTRACTORS**

Doc no.: HSEP: 14

REV: 01

Date: 20.01.2020

POWER SECTOR

Page: 18 of 43

- Electrical safety
- Welding, NDE & Radiological safety
- Storage, preservation & material handling.
- A matrix shall be maintained to keep an up-to-date record of attendance of training sessions carried out.

## 9.5 HSE PROMOTION-SIGNAGE, POSTERS, COMPETITION, AWARDS ETC

### 9.5.1 Display of HSE posters and banners

- Site shall arrange appropriate posters, banners, slogans in local/Hindi/English languages at work place

### 9.5.2 Display of HSE signage

- Appropriate HSE signage shall be displayed at the work area to aware workmen and passersby about the work going on and do's and don'ts to be followed

### 9.5.3 Competition on HSE and award

- Site will arrange different competition (slogan, poster, essay etc.) on HSE time to time (Safety day, BHEL day, World Environment Day etc.) and winners will be suitably awarded.

### 9.5.4 HSE awareness programme

- Subcontractor shall arrange HSE awareness programme periodically on different topics including medical awareness for all personnel working at site

## 10.0 HSE COMMUNICATION

### 10.1 INCIDENT REPORTING

- The subcontractor shall submit report of all incidents, fires and property damage etc to the Engineer immediately after such occurrence, but in any case not later than 24 hours of the occurrence. Such reports shall be furnished in the manner prescribed by BHEL. ( Refer HSE procedure for incident investigation, analysis and reporting for details)
- In addition, periodic reports on safety shall also be submitted by the subcontractor to BHEL from time to time as prescribed by the Engineer. Compiled monthly reports of all kinds of incidents, fire and property damage to be submitted to BHEL safety officer as per prescribed formats.
- HSE incidents of site shall be reported to BHEL site Management as per Procedure for Incident Investigation and Reporting in format no. HSEP:14-F15. Corrective action shall be immediately implemented at the work place and compliance shall be verified by BHEL HSE officer and until then, work shall be put on hold by Construction Manager.

### 10.2 HSE EVENT REPORTING

- Important HSE events like HSE training, Medical camp etc. organized at site shall be reported to BHEL site management in detail with photographs for publication in different in-house magazines
- Celebration of important days like National Safety Day, World Environment Day etc. shall also be reported as mentioned above.

### 10.3 DAILY HSE ACTIVITY REPORTING

Daily HSE activities shall be reported by subcontractor to BHEL as per Format No. HSEP:14-F31A



**HEALTH, SAFETY AND ENVIRONMENT  
PLAN FOR  
SITE OPERATION by SUBCONTRACTORS**

Doc no.: HSEP: 14

REV: 01

POWER SECTOR

Date: 20.01.2020

Page: 19 of 43

**11.0 OPERATIONAL CONTROL**

All applicable OCPs (Operational control procedures) will be followed by subcontractor as per BHEL instructions. This will be done as part of normal scope of work. List of such OCPs is given below. In case any other OCP is found to be applicable during the execution of work at site, then subcontractor will follow this as well, within quoted rate. These OCPs (applicable ones) will be made available to subcontractor during work execution at site. However for reference purpose, these are kept with Safety Officer of BHEL at the Power Sector Regional HQ, or available in downloadable format in the website, which may be referred by subcontractor, if they so desire.

**LIST OF OCPs**

Safe handling of chemicals	Safety in use of cranes	Hydraulic test
Electrical safety	Storage and handling of gas cylinders	Spray insulation
Energy conservation	Manual arc welding	Trial run of rotary equipment
Safe welding and gas cutting operation	Safe use of helmets	Stress relieving
Fire safety	Good house keeping	Material preservation
Safety in use of hand tools	Working at height	Cable laying/tray work
First aid	Safe excavation	Transformer charging
Food safety at canteen	Safe filling of hydrogen in cylinder	Electrical maintenance
Illumination	Vehicle maintenance	Safe handling of battery system
Handling and erection of heavy metals	Safe radiography	Computer operation
Safe acid cleaning	Waste disposal	Storage in open yard
Safe alkali boil out	Working at night	For sanitary maintenance
Safe oil flushing	Blasting	Batching
Steam blowing	DG set	Piling rig operation
Safe working in confined area	Handling & storage of mineral wool	Gas distribution test
Safe operation of passenger lift, material hoists & cages	Drilling, reaming and grinding(machining)	Cleaning of hotwell / deaerator
Electro-resistance heating	Compressor operation	O&M of control of AC plant & system
Air compressor	Passivation	Safe Loading of Unit
Safe EDTA Cleaning	Safe Chemical cleaning of Pre boiler system	Safe Boiler Light up
Safe Rolling and Synchronization		

**11.1 HSE ACTIVITIES**

HSE activities shall be conducted at site based on the HSEMSM developed by Power Sector and issued to site by Regions.

While planning for any activity the following documents shall be referred for infrastructural requirements to establish control measures:

- 1) HSE Procedure for Register of OHS Hazards and Risks
- 2) HSE Procedure for Register of Environmental Aspects and Impacts
- 3) HSE Procedure for Register of Regulations



**HEALTH, SAFETY AND ENVIRONMENT  
PLAN FOR  
SITE OPERATION by SUBCONTRACTORS**

Doc no.: HSEP: 14

REV: 01

Date: 20.01.2020

POWER SECTOR

Page: 20 of 43

- 4) Operational Control Procedures
- 5) HSE Procedure for Emergency Preparedness and Response Plan
- 6) Contract documents

### 11.2 WORK PERMIT SYSTEM

- The following activities shall come under Work Permit System
  - a. Height working above 2 metres
  - b. Hot working at height
  - c. Confined space
  - d. Radiography
  - e. Excavation more than 4 meter depth
  - f. Heavy lifting above 50 tonRefer Annexure 05 for Work permit formats.
- "HSE Procedure for Work Permit System" shall be followed while implementing permit system. Where customer is having separate Work Permit System the same shall be followed.
- Permit applicant shall apply for work permit of particular work activity at particular location before starting of the work with Job Hazard Analysis.
- Permit signatory shall check that all the control measures necessary for the activity are in place and issue the permit to the permit holder.
- Permit holder shall implement and maintain all control measures during the period of permit .He will close the permit after completion of the work. The closed permit shall be archived in HSE Department of site.

### 11.3 SAFETY DURING WORK EXECUTION

Respective OCPS are to be followed and adherence to the same would be contractually binding

#### 11.3.1 WELDING SAFETY

All safety precautions shall be taken for welding and cutting operations as per IS-818. All safety precautions shall be taken for foundation and other excavation marks as per IS-3764.

#### 11.3.2 RIGGING

Rigging equipment shall not be loaded in excess of its recommended safe working load. Rigging equipment, when not in use, shall be removed from the original work area so as not to present a hazard to employees.

#### 11.3.3 CYLINDERS STORAGE AND MOVEMENT

All gas cylinders shall be stored in upright position. Suitable trolley shall be used. There shall be flash-back arrestors conforming to IS-11006 at both cylinder and burner ends. Damaged tube and regulators must be immediately replaced. No of cylinders shall not exceed the specified quantity as per OCP

Cylinders shall be moved by tilting and rolling them on their bottom edges. They shall not be intentionally dragged, struck or permitted to strike each other violently.



**HEALTH, SAFETY AND ENVIRONMENT  
PLAN FOR  
SITE OPERATION by SUBCONTRACTORS**

Doc no.: HSEP: 14

REV: 01

POWER SECTOR

Date: 20.01.2020

Page: 21 of 43

When cylinders are transported by powered vehicle they shall be secured in a vertical position.

#### 11.3.4 DEMOLITION WORK

Before any demolition work is commenced and also during the process of the work the following shall be ensured:

- All roads and open areas adjacent to the work site shall either be closed or suitably protected.
- No electric cable or apparatus which is liable to be a source of danger nor a cable or an apparatus used by the operator shall remain electrically charged.
- All practical steps shall be taken to prevent danger to persons employed from the risks of fire or explosion or flooding. No floor, roof or other part of the building shall be so overloaded with debris or materials as to render them unsafe.

#### 11.3.5 T&Ps

All T&Ps/ MMEs should be of reputed brand/appropriate quality & must have valid test/calibration certificates bearing endorsement from competent authority of BHEL..Subcontractor to also submit monthly reports of T&Ps deployed and validity test certificates to BHEL safety Officer as per the format/procedure of BHEL.

#### 11.3.6 CHEMICAL HANDLING

Displaying safe handling procedures for all chemicals such as lube oil, acid, alkali, sealing compounds etc , at work place. Where it is necessary to provide and/or store petroleum products or petroleum mixture & explosives, the subcontractor shall be responsible for carrying out such provision / storage in accordance with the rules & regulations laid down in the relevant petroleum act, explosive act and petroleum and carbide of calcium manual, published by the chief inspector of explosives of India. All such storage shall have prior approval if necessary from the chief inspector of explosives or any other statutory authority. The subcontractor shall be responsible for obtaining the same.

#### 11.3.7 ELECTRICAL SAFETY

- Providing adequate no. of 24 V sources and ensure that no hand lamps are operating at voltage level above 24 Volts.
- Fulfilling safety requirements at all power tapping points.
- High/ Low pressure welders to be identified with separate colour clothings. No welders will be deployed without passing appropriate tests and holding valid welding certificates. Approved welding procedure should be displayed at work place.
- The subcontractor shall not use any hand lamp energized by Electric power with supply voltage of more than 24 volts in confined spaces like inside water boxes, turbine casings, condensers etc.
- All portable electric tools used by the subcontractor shall have safe plugging system to source of power and be appropriately earthed. Only electricians licensed by appropriate statutory authority shall be employed by the subcontractor to carry out all types of electrical works. Details of earth resource and their test date to be given to BHEL safety officer as per the prescribed formats of BHEL
- The subcontractor shall use only properly insulated and armored cables which conform to the requirement of Indian Electricity Act and Rules for all wiring, electrical applications at site.



**HEALTH, SAFETY AND ENVIRONMENT  
PLAN FOR  
SITE OPERATION by SUBCONTRACTORS**

Doc no.: HSEP: 14

REV: 01

Date: 20.01.2020

POWER SECTOR

Page: 22 of 43

- BHEL reserves the right to replace any unsafe electrical installations, wiring, cabling etc. at the cost of the subcontractor.
- All electrical appliances used in the work shall be in good working condition and shall be properly earthed.
- No maintenance work shall be carried out on live equipment.
- The subcontractor shall maintain adequate number of qualified electricians to maintain his temporary electrical installations.
- Area wise Electrical safety inspection is to be carried out on monthly basis as per "Electrical Safety Inspection checklist" and the report is to be submitted to BHEL safety officer
- Adequate precautions shall be taken to prevent danger for electrical equipment. No materials on any of the sites of work shall be so stacked or placed as to cause danger or inconvenience to any person or the public
- The subcontractor shall carefully follow the safety requirement of BHEL/ the purchaser with the regard to voltages used in critical areas.

#### 11.3.8 FIRE SAFETY

- Providing appropriate fire fighting equipment at designated work place and nominate a fire officer/warden adequately trained for his job.
- Subcontractor shall provide enough fire protecting equipment of the types and numbers at his office, stores, temporary structure in labor colony etc. Such fire protection equipment shall be easy and kept open at all times.
- The fire extinguishers shall be properly refilled and kept ready which should be certified at periodic intervals. The date of changing should be marked on the Cylinders.
- All other fire safety measures as laid down in the "codes for fire safety at construction site" issued by safety coordinator of BHEL shall be followed.
- Non-compliance of the above requirement under fire protection shall in no way relieve the subcontractor of any of his responsibility and liabilities to fire incident occurring either to his materials or equipment or those of others.
- Emergency contacts nos must be displayed at prominent locations
- Tarpaulin being inflammable should not be used (instead, only non-infusible covering materials shall be used) as protective cover while preheating, welding, stress relieving etc. at site.

#### 11.3.9 SCAFFOLDING

- Suitable scaffolds shall be provided for workman for all works that cannot safely be done from the ground, or from solid construction except in the case of short duration of work which can be done safely from ladders.
- When a ladder is used, it shall be of rigid construction made of steel. The steps shall have a minimum width of 45 cm and a maximum rise of 30 cm. Suitable handholds of good quality wood or steel shall be provided and the ladder shall be given an inclination not steeper than ¼ horizontal and 1 vertical.
- Scaffolding or staging more than 3.6 m above the ground floor, swung or suspended from an overhead support or erected with stationery support shall have a guard rail properly bolted, braced or otherwise secured, at least 90 cm above the floor or platform of such scaffolding or staging and extending along the entire length of the outside and ends thereof with only such openings as may be necessary for the delivery of materials. Such scaffolding or staging shall be so fastened as to prevent it from savor, from swaying, from the building or structure.

#### 11.3.10 WORK AT HEIGHT:

- Guardrails and toe-board/barricades and sound platform conforming to IS:4912-1978 should be provided.



**HEALTH, SAFETY AND ENVIRONMENT  
PLAN FOR  
SITE OPERATION by SUBCONTRACTORS**

Doc no.: HSEP: 14

REV: 01

Date: 20.01.2020

POWER SECTOR

Page: 23 of 43

- Wherever necessary, life-line (pp or metallic) and fall arrestor along with Polyamide rope or Retractable lifeline should be provided.
- Safety Net as per IS:11057:1984 should be used extensively for prevention/ arrest of men and materials falling from height. The safety nets shall be fire resistant, duly tested and shall be of ISI marked and the nets shall be located as per site requirements to arrest or to reduce the consequences of a possible fall of persons working at different heights.
- Reaching beyond barricaded area without lifeline support, moving with support of bracings, walking on beams without support, jumping from one level to another, throwing objects and taking shortcut must be discouraged.
- Use of Rebar steel for making Jhoola and monkey-ladder (Rods welded to vertical or inclined structural members), temporary platform etc. must be avoided.
- Monkey Ladder should be properly made and fitted with cages.
- Jhoola should be made with angles and flats and tested like any lifting tools before use.
- Lanyard must be anchored always and in case of double lanyard, each should be anchored separately.
- In case of pipe-rack, persons should not walk on pipes and walk on platforms only.
- In case of roof work, walking ladder/ platform should be provided along with lifeline and/ or fall arrestor.
- Empty drums must not be used.
- For chimney or structure painting, both hanging platform and men should be anchored separately to a firm structure along with separate fall arrestor. Rope ladder should be discouraged.

#### 11.3.11 WORKING PLATFORM

Working platforms, gangways and stairways shall be so constructed that they do not sag unduly or unequally and if the height of the platform gangways provided is more than 3.6 m above ground level or floor level, they shall be closely boarded and shall have adequate width which shall not be less than 750 mm and be suitably fenced as described above. Every opening in the floor or a building or in a working platform shall be provided with suitable means to prevent the fall of persons or materials by providing suitable fencing or railing whose minimum height shall be 90 cm.

#### 11.3.12 EXCAVATION

Wherever there are open excavation in ground, they shall be fenced off by suitable railing and danger signals installed at night so as to prevent persons slipping into the excavations.

#### 11.3.13 LADDER SAFETY

Safe means of access shall be provided to all working places. Every ladder shall be securely fixed. No portable single ladder shall be over 9 m in the length while the width between side rails in rung ladder shall in no case be less than app. 29.2 cm for ladder upto and including 3 m in length. For longer ladders this width shall be increased at least ¼" for each additional foot of length.

A sketch of the ladders and scaffolds proposed to be used shall be prepared and approval of the Engineer obtained prior to Construction.

#### 11.3.14 LIFTING SAFETY

- It will be the responsibility of the subcontractor to ensure safe lifting of the equipment, taking due precaution to avoid any incident and damage to other equipment and personnel.



**HEALTH, SAFETY AND ENVIRONMENT  
PLAN FOR  
SITE OPERATION by SUBCONTRACTORS**

Doc no.: HSEP: 14

REV: 01

Date: 20.01.2020

Page: 24 of 43

**POWER SECTOR**

- All requisite tests and inspection of handling equipment, tools & tackle shall be periodically done by the subcontractor by engaging only the Competent Persons as per law.
- Defective equipment or uncertified shall be removed from service.
- Any equipment shall not be loaded in excess of its recommended safe working load.

**11.3.15 HOISTING APPLIANCE**

- Motors, gearing, transmission, electric wiring and other dangerous parts of hoisting appliances should be provided with efficient safe guards.
- Hoisting appliance should be provided with such means as will reduce to the minimum the risk of any part of a suspended load becoming incidentally displaced.
- When workers employed on electrical installations which are already energized, insulating mats, wearing apparel, such as gloves, sleeves and boots as may be necessary should be provided.
- The worker should not wear any rings, watches and carry keys or other materials which are good conductor of electricity.

**11.4 ENVIRONMENTAL CONTROL**

Environment protection has always been given prime importance by BHEL. Environmental damage is a major concern of the principal subcontractor and every effort shall be made, to have effective control measures in place to avoid pollution of Air, Water and Land and associated life. Chlorofluorocarbons such as carbon tetrachloride and trichloroethylene shall not be used. Waste disposal shall be done in accordance with the guidelines laid down in the project specification.

Any chemical including solvents and paints, required for construction shall be stored in designated bonded areas around the site as per Material Safety Data Sheet (MSDS).

In the event of any spillage, the principle is to recover as much material as possible before it enters drainage system and to take all possible action to prevent spilled materials from running off the site. The subcontractor shall use appropriate MSDS for clean-up technique

All subcontractors shall be responsible for the cleanliness of their own areas.

The subcontractors shall ensure that noise levels generated by plant or machinery are as low as reasonably practicable. Where the subcontractor anticipates the generation of excessive noise levels from his operations the subcontractor shall inform to Construction Manager of BHEL accordingly so that reasonable & practicable precautions can be taken to protect other persons who may be affected.

It is imperative on the part of the subcontractor to join and effectively contribute in joint measures such as tree plantation, environment protection, contributing towards social upliftment, conversion of packing woods to school furniture, keeping good relation with local populace etc.

The subcontractor shall carry out periodic air and water quality check and illumination level checking in his area of work place and take suitable control measure.

**11.5 HOUSEKEEPING**

- Keeping the work area clean/ free from debris, removed scaffoldings, scraps, insulation/sheeting wastage /cut pieces, temporary structures, packing woods etc. will be in the scope of the subcontractor. Such cleanings has to be done by



**HEALTH, SAFETY AND ENVIRONMENT  
PLAN FOR  
SITE OPERATION by SUBCONTRACTORS**

Doc no.: HSEP: 14

REV: 01

Date: 20.01.2020

POWER SECTOR

Page: 25 of 43

subcontractor within quoted rate, on daily basis by an identified group. If such activity is not carried out by subcontractor / BHEL is not satisfied, then BHEL may get it done by other agency and actual cost along with BHEL overheads will be deducted from contractor's bill. Such decisions of BHEL shall be binding on the subcontractor

- Proper housekeeping to be maintained at work place and the following are to be taken care of on daily basis.
- All surplus earth and debris are removed/disposed off from the working areas to identified locations.
- Unused/Surplus cables, steel items and steel scrap lying scattered at different places/elevation within the working areas are removed to identified locations.
- All wooden scrap, empty wooden cable drums and other combustible packing materials, shall be removed from workplace to identified locations. Sufficient waste bins shall be provided at
- Different work places for easy collection of scrap/waste. Scrap chute shall be installed to remove scrap from high location.
- Access and egress (stair case, gangways, ladders etc.) path should be free from all scrap and other hindrances.
- Workmen shall be educated through tool box talk about the importance of housekeeping and encourage not to litter.
- Labour camp area shall be kept clear and materials like pipes, steel, sand, concrete, chips and bricks, etc. shall not be allowed in the camp to obstruct free movement of men and machineries.
- Fabricated steel structures, pipes & piping materials shall be stacked properly.
- No parking of trucks/trolleys, cranes and trailers etc. shall be allowed in the camp, which may obstruct the traffic movement as well as below LT/HT power line.
- Utmost care shall be taken to ensure over all cleanliness and proper upkeep of the working areas

#### 11.6 WASTE MANAGEMENT

Take suitable measures for waste management and environment related laws/legislation as a part of normal construction activities. Compliance with the legal requirements on storage/ disposal of paint drums (including the empty ones), Lubricant containers, Chemical Containers, and transportation and storage of hazardous chemicals will be strictly maintained.

##### 11.6.1 BINS AT WORK PLACE

- Sufficient rubbish bins shall be provided close to workplaces.
- Bins should be painted yellow and numbered.
- Sufficient nos. of drip trays shall be provided to collect oil and grease.
- Sufficient qty. of broomsticks with handle shall be provided.
- Adequate strength of employees should be deployed to ensure daily monitoring and service for waste management.

##### 11.6.2 STORAGE AND COLLECTION

- Different types of rubbish/waste should be collected and stored separately.
- Paper, oily rags, smoking material, flammable, metal pieces should be collected in separate bins with close fitting lids.
- Rubbish should not be left or allowed to accumulate on construction and other work places.
- Do not burn construction rubbish near working site.



**HEALTH, SAFETY AND ENVIRONMENT  
PLAN FOR  
SITE OPERATION by SUBCONTRACTORS**

Doc no.: HSEP: 14

REV: 01

Date: 20.01.2020

POWER SECTOR

Page: 26 of 43

### 11.6.3 SEGREGATION

- Earmark the scrap area for different types of waste.
- Store wastes away from building.
- Oil spill absorbed by non-combustible absorbent should be kept in separate bin.
- Clinical and first aid waste stored and incinerated separately.

### 11.6.4 DISPOSAL

- Sufficient containers and scrap disposal area should be allocated.
- All scrap bin and containers should be conveniently located.
- Provide self-closing containers for flammable/spontaneously combustible material.
- Keep drainage channels free from choking.
- Make schedule for collection and disposal of waste.

### 11.6.5 WARNING AND SIGNS

- Appropriate sign to be displayed at scrap storage area
- No toxic, corrosive or flammable substance to be discarded into public sewage system.
- Waste disposal shall be in accordance with best practice.
- Comply with all the requirements of Pollution Control Board (PCB) for storage and disposal of hazardous waste.

## 11.7 TRAFFIC MANAGEMENT SYSTEM

### 11.7.1 SAFE WORKPLACE TRANSPORT SYSTEM

- Traffic routes in a work place shall be suitable for the persons or vehicles using them. This shall be sufficient in number and of sufficient size. This shall reflect the suitability of traffic routes for vehicles and pedestrians.
- Where vehicles and pedestrians use the same traffic routes there shall be sufficient space between them. Where necessary all traffic routes must be suitably indicated. Pedestrians or vehicles must be able to use traffic routes without endangering those at work. There must be sufficient separation of traffic routes from doors, gates and pedestrian traffic routes.
- For internal traffic, lines marked on roads / access routes and between buildings shall clearly indicate where vehicles are to pass.
- Temporary obstacles shall be brought to the attention of drivers by warning signs or hazard cones.
- Speed limits shall be clearly displayed. Speed ramps preceded by a warning signs or marker are necessary.
- The traffic route should be wide enough to allow vehicles to pass and re-pass oncoming or parked traffic and it may be advisable to introduce on-way system or parking restrictions.
- Safest route shall be provided between places where vehicles have to call or deliver.
- Avoid vulnerable areas/items such as fuel or chemicals tanks or pipes, open or unprotected edges and structures likely to collapse



**HEALTH, SAFETY AND ENVIRONMENT  
PLAN FOR  
SITE OPERATION by SUBCONTRACTORS**

Doc no.: HSEP: 14

REV: 01

Date: 20.01.2020

POWER SECTOR

Page: 27 of 43

- Safe areas shall be provided for loading and unloading.
- Avoid sharp or blind bends. If this is not possible hazards should be indicated e.g. blind corner.
- Ensure road crossings are minimum and clearly signed.
- Entrance and gateways shall be wide enough to accommodate a second vehicle without causing obstruction.
- Set sensible speed limits which are clearly sign posted.
- Where necessary ramps should be used to retard speed. This shall be preceded by a warning sign or mark on the road.
- Forklift trucks shall not pass over road hump unless of a type capable of doing so.
- Overhead electric cable, pipes containing flammable hazardous chemical shall be shielded by using goal posts height gauge posts or barriers.
- Road traffic signs shall be provided on prominent locations for prevention of incidents and hazards and for quick guidance and warning to employees and public. Safety signs shall be displayed as per the project working requirement and guideline of the state in which project is done. Vehicles hired or used shall not be parked within the 15m radius of any working area. Any vehicle, that is required to be at the immediate/near the vicinity, shall be approved by the person in-charge of the site.

#### 11.7.2 TRAFFIC ROUTE FOR PEDESTRIANS

- Where traffic routes are used by both pedestrians and vehicles road shall be wide enough to allow vehicles and pedestrians safely.
- Separate routes shall be provided for pedestrians to keep them away from vehicles. Provide suitable barriers/guard at entrances/exit and the corners or buildings.
- Where pedestrian and vehicle routes cross, appropriate crossing shall be provided.
- Where crowd is likely to use roadway e.g. at the end of shift, stop vehicles from using them at such times.
- Provide high visibility clothing for people permitted in delivery area.

#### 11.7.3 WORK VEHICLE

Work vehicle shall be as safe stable efficient and roadworthy as private vehicles on public roads. Site management shall ensure that drivers are suitably trained. All vehicle e.g. heavy motor vehicle forklift trucks dump trucks mobile cranes shall ensure that the work equipment conforms to the following:

- A high level of stability.
- A safe means of access/egress.
- Suitable and effective service and parking brakes.
- Windscreens with wipers and external mirrors giving optimum all round visibility.
- Provision of horn, vehicle lights, reflectors, reversing lights, reversing alarms.
- Provision of seat belts.
- Guards on dangerous parts.
- Driver protection - to prevent injury from overturning and from falling objects/materials.
- Driver protection from adverse weather.
- No vehicle shall be parked below HT/LT power lines.
- Valid Pollution Under Control certification for all vehicles



**HEALTH, SAFETY AND ENVIRONMENT  
PLAN FOR  
SITE OPERATION by SUBCONTRACTORS**

Doc no.: HSEP: 14

REV: 01

POWER SECTOR

Date: 20.01.2020

Page: 28 of 43

#### 11.7.4 DAILY CHECK BY DRIVER

- There should also be daily safety checks containing below mentioned points by the driver before the vehicle is used.
  - Brakes.
  - Tires.
  - Steering.
  - Mirrors.
  - Windscreen waters.
  - Wipers.
  - Warning signals.
  - Specific safety system i.e. control interlocks
- Management should ensure that drivers carry out these checks.

#### 11.7.5 TRANSPORTATION OF PERSONNEL AND MATERIALS BY VEHICLES

- All drivers shall hold a valid driving License for the class of vehicle to be driven and be registered as an authorized BHEL driver with the Administration Department.
- Securing of the load shall be by established and approved methods, i.e. chains with patented tightening equipment for steel/heavy loads. Sharp corners on loads shall be avoided when employing ropes for securing.
- All overhangs shall be made clearly visible and restricted to acceptable limits
- Load shall be checked before moving off and after traveling a suitable distance.
- On no account is construction site to be blocked by parked vehicles Drivers of vehicles shall only stop or park in the areas designate by the stringing foreman.
- Warning signs shall be displayed during transportation of material.  
All vehicles used by BHEL shall be in worthy condition and in conformance to the Land Transport requirement.

#### 11.7.6 MAINTENANCE

All Vehicles used for transportation of man and material shall undergo scheduled inspections on frequent intervals to secure safe operation. Such inspections shall be conducted in particular for steering, brakes, lights, horn, doors etc. Site management shall ensure that work equipment is maintained in an efficient, working order and in good repair. Inspections and services carried out at regular intervals of time and or mileage. No maintenance shall be carried below HT/LT power lines.

#### 11.8 EMERGENCY PREPAREDNESS AND RESPONSE

- Emergency preparedness and response capability of site shall be developed as per Emergency Preparedness and Response plan issued by Regional HQ
- Availability of adequate number of first aiders and fire warden shall be ensured with BHEL and its subcontractors
- All the subcontractor's supervisory personnel and sufficient number of workers shall be trained for fire protection systems. Enough number of such trained personnel must be available during the tenure of contract. Subcontractor should nominate his supervisor to coordinate and implement the safety measures.
- Assembly point shall be earmarked and access to the same from different location shall be shown
- Fire exit shall be identified and pathway shall be clear for emergency escape.



**HEALTH, SAFETY AND ENVIRONMENT  
PLAN FOR  
SITE OPERATION by SUBCONTRACTORS**

Doc no.: HSEP: 14

REV: 01

POWER SECTOR

Date: 20.01.2020

Page: 29 of 43

- Appropriate type and number of fire extinguisher shall be deployed as per Fire extinguisher deployment plan and validity shall be ensured periodically through inspection
- Adequate number of first aid boxes shall be strategically placed at different work places to cater emergency need. Holder of the first aid box shall be identified on the box itself who will have the responsibility to maintain the same.
- First aid center shall be developed at site with trained medical personnel and ambulance
- Emergency contact numbers (format given in EPRP) of the site shall be displayed at prominent locations.
- Tie up with fire brigade shall be done in case customer is not having fire station.
- Tie up with hospital shall be done in case customer is not having hospital.
- Disaster Management group shall be formed at site
- Mock drill shall be arranged at regular intervals. Monthly report of the above to be given to BHEL safety Officer as per prescribed BHEL formats
- Mock drill shall be conducted on different emergencies periodically to find out gaps in emergency preparedness and taking necessary corrective action

## 12.0 HSE INSPECTION

Inspection on HSE for different activities being carried out at site shall be done to ensure compliance to HSEMS requirements. The subcontractor shall maintain and ensure necessary safety measures as required for inspection and tests HV test, Pneumatic test, Hydraulic test, Spring test, Bend test etc. as applicable, to enable inspection agency for performing Inspection. If any test equipment is found not complying with proper safety requirements then the Inspection Agency may withhold inspection, till such time the desired safety requirements are met.

### 12.1 DAILY HSE CHECKS

Both the Site Supervisors and safety officer of Subcontractor are to conduct daily site Safety inspection around work activities and premises to ensure that work methods and the sites are maintained to an acceptable standard. The following are to form the common subjects of a daily safety inspection:

- Personal Safety wears & gear compliance.
- Complying with site safety rules and permit-to-work (PTW).
- Positions and postures of workers.
- Use of tools and equipment etc. by the workers.

The inspection should be carried out just when work starts in beginning of the day, during peak activities period of the day and just before the day's work ends.

### 12.2 INSPECTION OF PPE

- PPEs shall be inspected by HSE officer at random once in a week as per format no. HSEP:14-F06 for its compliance to standard and compliance to use and any adverse observation shall be recorded in the PPE register.
- The applicable PPEs for carrying out particular activities are listed below.



**HEALTH, SAFETY AND ENVIRONMENT  
PLAN FOR  
SITE OPERATION by SUBCONTRACTORS**

Doc no.: HSEP: 14

REV: 01

Date: 20.01.2020

POWER SECTOR

Page: 30 of 43

### 12.3 INSPECTION OF T&Ps

- A master list of T&Ps shall be maintained by each subcontractor.
- All T&Ps being used at site shall be inspected by HSE officer once in a month as per format no. HSEP:14-F07 for its healthiness and maintenance.
- The T&Ps which require third party inspection shall be checked for its validity during inspection. The third party test certificate should be accompanied with a copy of the concerned competent person's valid qualification record.
- The validity of T&P shall be monitored as per "Status of T&Ps" format no. HSEP:14-F08

### 12.4 INSPECTION OF CRANES AND WINCHES

- Cranes and winches shall be inspected by the operator through a daily checklist for its safe condition (as provided by the equipment manufacturer) before first use of the day.
- Cranes and Winches shall be inspected by HSE officer once in a month as per format no. HSEP:14-F09 for healthiness, maintenance and validity of third party inspection.
- The date of third party inspection and next due date shall be painted on cranes and winches.
- The operators/drivers shall be authorized by sub-contractor based on their competency and experience and shall carry the I-card.
- The operator should be above 18 years of age and should be in possession of driving license of HMV man & goods), vision test certificate and should have minimum qualification so that he can read the instructions and check list.

### 12.5 INSPECTION ON HEIGHT WORKING

- Inspection on height working shall be conducted daily by supervisors before start of work to ensure safe working condition including provision of
  - Fall arrestor
  - Lifelines
  - Safety nets
  - Fencing and barricading
  - Warning signage
  - Covering of opening
  - Proper scaffolding with access and egress.
  - Illumination
- Inspection on height working shall be conducted once in a week by HSE officer as per format no. HSEP:14-F10.
- Medical fitness of height worker shall be ensured.
- Height working shall not be allowed during adverse weather.

### 12.6 INSPECTION ON WELDING AND GAS CUTTING OPERATION

- Supervisor shall ensure that no flammable items are available in near vicinity during welding and gas cutting activity.
- Gas cylinders shall be kept upright.
- Use of Flash back arrestor shall be ensured at both ends.



**HEALTH, SAFETY AND ENVIRONMENT  
PLAN FOR  
SITE OPERATION by SUBCONTRACTORS**

Doc no.: HSEP: 14

REV: 01

Date: 20.01.2020

POWER SECTOR

Page: 31 of 43

- Inspection during welding and gas cutting operations shall be carried out by HSE officer once a month as per format no. HSEP:14-F11.
- Use of fire blanket to be ensured to avoid falling of splatters during welding or gas cutting operation at height.
- Availability of fire extinguisher at vicinity shall be ensured.

**12.7 INSPECTION ON ELECTRICAL INSTALLATION / APPLIANCES**

- Ensure proper earthing in electrical installation
- Use ELCB at electrical booth
- Electrical installation shall be properly covered at top where required
- Use appropriate PPEs while working
- Use portable electrical light < 24 V in confined space and potentially wet area.
- Monthly inspection shall be carried out as per format no. HSEP:14-F12.

**12.8 INSPECTION OF ELEVATOR**

- Elevators shall be inspected by concerned supervisors once in a week as per format no. HSEP:14-F13.
- All elevators shall be inspected by competent person and validity shall be ensured.
- The date of third party inspection and next due date shall be painted on elevator.

**12.9 INSPECTION OF EXCAVATION**

Excavation activities shall be inspected as per Format HSEP:14-F13A

**13.0 HSE PERFORMANCE**

- Contractor shall be assessed on monthly basis for HSE Compliance by BHEL Safety In-charge at site. The HSE compliance shall be based on Online HSE Evaluation System of BHEL as per Format No. HSEP:14-F33.
- BHEL shall reserve the right to use this assessment for evaluating bidder's capacity for future tenders
- Suitable HSE reward system shall be developed at site level to promote HSE compliance amongst workmen by the subcontractor.  
To decide HSE reward, performance towards HSE shall be evaluated for workmen and it shall be awarded regularly in public gathering.
- If safety record of the subcontractor in execution of the awarded job is to the satisfaction of safety department of BHEL, issue of an appropriate certificate to recognize the safety performance of the subcontractor may be considered by BHEL after completion of the job.



**HEALTH, SAFETY AND ENVIRONMENT  
PLAN FOR  
SITE OPERATION by SUBCONTRACTORS**

Doc no.: HSEP: 14

REV: 01

Date: 20.01.2020

POWER SECTOR

Page: 32 of 43

#### 14.0 HSE PENALTIES

- As per contractual provision HSE penalties shall be imposed on subcontractors for non-compliance on HSE requirement as per format no. HSEP:14-F14. The list in the format is only indicative. For any other violation, not listed in the format, the minimum penalty amount is to be decided as per BOCW act.
- If principal customer/statutory and regulatory bodies impose some penalty on HSE due to the non-compliance of the subcontractor the same shall be passed on to them.
- The penalty amount shall be recovered by Site Finance department from subcontractors from the RA/Final bill.

#### 15.0 OTHER REQUIREMENTS

- In case of any delay in completion of a job due to mishaps attributable to lapses by the subcontractor, BHEL shall have the right to recover cost of such delay from the payments due to the subcontractor, after notifying the subcontractor suitably.
- If the subcontractor fails to improve the standards of safety in its operation to the satisfaction of BHEL after being given reasonable opportunity to do so and/or if the subcontractor fails to take appropriate safety precautions or to provide necessary safety devices and equipment or to carry out instruction regarding safety issued by BHEL, BHEL shall have the right to take corrective steps at the risk and cost of the subcontractor after giving a notice of not less than 7 days indicating the steps that would be taken by BHEL.
- If the subcontractor succeeds in carrying out its job in time without any fatal or disabling injury incident and without any damage to property BHEL may, at its sole discretion, favorably consider to reward the subcontractor suitably for the performance.
- In case of any damage to property due to lapses by the subcontractor, BHEL shall have the right to recover the cost of such damages from the subcontractor after holding an appropriate enquiry.
- The subcontractor shall take all measures at the sites of the work to protect all persons from incidents and shall be bound to bear the expenses of defense of every suit, action or other proceeding of law that may be brought by any persons for injury sustained or death owing to neglect of the above precautions and to pay any such persons such compensation or which may with the consent of the subcontractor be paid to compromise any claim by any such person, should such claim proceeding be filed against BHEL, the subcontractor hereby agrees to indemnify BHEL against the same.
- The subcontractor shall not employ men below the age of 18 years and women on the work of painting with products containing lead in any form. Wherever men above the age of 18 are employed on the work of lead painting, overalls shall be supplied by the subcontractor to the workmen and adequate facilities shall be provided to enable the working painters to wash during the cessation of work.
- The subcontractor shall notify BHEL of his intention to bring to site any equipment or material which may create hazard.
- BHEL shall have the right to prescribe the conditions under which such equipment or materials may be handled and the subcontractor shall adhere to such instructions.



**HEALTH, SAFETY AND ENVIRONMENT  
PLAN FOR  
SITE OPERATION by SUBCONTRACTORS**

Doc no.: HSEP: 14

REV: 01

POWER SECTOR

Date: 20.01.2020

Page: 33 of 43

- BHEL may prohibit the use of any construction machinery, which according to the organization is unsafe. No claim for compensation due to such prohibition will be entertained by BHEL.

#### 16. NON COMPLIANCE

NONCONFORMITY OF SAFETY RULES AND SAFETY APPLIANCES WILL BE VIEWED SERIOUSLY AND BHEL HAS RIGHT TO IMPOSE FINES ON THE SUBCONTRACTOR AS UNDER FOR EVERY INSTANCE OF VIOLATION NOTICED:

SN	Violation of Safety Norms	Fine (in Rs)
01	Not Wearing Safety Helmet	200/- *
02.	Not wearing Safety Belt or not anchoring life line	500/-*
03	Not wearing safety shoe	200/-*
04	Not keeping gas cylinders vertically	200/-
05	Not using flash back arrestors	100/-
06	Not wearing gloves	50/- *
07.	Grinding Without Goggles	50/- *
08.	Not using 24 V Supply For Internal Work	500/-
09.	Electrical Plugs Not used for hand Machine	100/-
10.	Not Slings properly	200/-
11.	Using Damaged Sling	200/-
12.	Lifting Cylinders Without Cage	500/-
13.	Not Using Proper Welding Cable With Lot of Joints And Not Insulated Property.	200/-
14.	Not Removing Small Scrap From Platforms	500/-
15.	Gas Cutting Without Taking Proper Precaution or Not Using Sheet Below Gas Cutting	500/-
16.	Not Maintaining Electric Winches Which are Operated Dangerously	500/-
17.	Improper Earthing Of Electrical T&P	500/-
18	No or improper barricading	500/-
19.	Activity carried out without Safety work permit (Height work, Lifting activity, Hot work-each person/case)	1000/-
20.	Incident Resulting in Partial Loss in Earning Capacity	25,000/- per victim
21.	Fatal Incident Resulting in total loss in Earning Capacity	1,00,000/- per victim for first instance #

- Legend:-

\*: per head. For repeated violation by the same person, the penalty would be double of the previous penalty. Date of "Repeated violation" will be counted from subsequent days.

#: or as deducted by customer, whichever is higher. For repeated fatal incident in the same Unit incremental penalty to be imposed. The subcontractor will pay 2 times the penalty compared to previously paid in case there are repeated cases of fatal incidents under the same subcontractor for the same package in the same unit.

Any other non-conformity noticed not listed above will also be fined as deemed fit by BHEL. The decision of BHEL engineer is final on the above. The amount will be deducted from running bills of the subcontractor. The amount collected above will be utilized for giving award to the employees who could avoid incident by following safety rules. Also the amount will be spent for purchasing the safety appliances and supporting the safety activity at site.



**HEALTH, SAFETY AND ENVIRONMENT  
PLAN FOR  
SITE OPERATION by SUBCONTRACTORS**

Doc no.: HSEP: 14

REV: 01

Date: 20.01.2020

POWER SECTOR

Page: 34 of 43

#### 17.0 HSE AUDIT/INSPECTION

- Regular HSE Audit/inspection shall be carried out by Subcontractor as per Site HSE audit calendar.
- HSE checklist (**Annexure 02**) shall be used for carrying out audit/inspection and report shall be submitted to BHEL site management
- All non-conformities and observations on HSE identified during internal or external HSE audit shall be disposed off by site in a time bound manner and reported back the implementation status
- Corrective action and Preventive action on HSE issues raised by certification body issued by Regional HQs shall be implemented by site and reported to Site management.

#### 18.0 MONTHLY HSE REVIEW MEETING

- Site shall hold HSE review meeting every month to discuss and resolve HSE issues of site and improve HSE performance. It will also discuss the incidents occurred since previous meeting, its root cause and Corrective action and Preventive action. The agenda is given below:
  - Implementation of earlier MOM
  - HSE performance
  - HSE inspection
  - HSE audit and CAPA
  - HSE training
  - Health check-up camp
  - HSE planning for the erection and commissioning and installation activities in the coming month
  - HSE reward and promotional activities
- The meeting shall be chaired by Construction Manager, convened by HSE coordinator and attended by all HOS, Site Incharge of Subcontractors and HSE officer of Subcontractors.
- MOM on the discussion will be circulated to the concerned for implementation.

#### 19.0 FORMATS USED (Details available in Annexure-04)

SL. No.	Format Name	Format No.	Rev No.
01	Inspection of First Aid Box	HSEP:14-F01	00
02	Health Check Up	HSEP:14-F02	00
03	HSE Induction Training	HSEP:14-F03	00
04	Tool Box Talk	HSEP:14-F04	00
05	Monthly Site HSE Report	As specified by BHEL	00
06	Inspection of PPE	HSEP:14-F06	00



**HEALTH, SAFETY AND ENVIRONMENT  
PLAN FOR  
SITE OPERATION by SUBCONTRACTORS**

Doc no.: HSEP: 14

REV: 01

Date: 20.01.2020

Page: 35 of 43

POWER SECTOR

07	Inspection of T&Ps	HSEP:14-F07	00
08	Status of T&Ps	HSEP:14-F08	00
09	Inspection of Cranes and Winches	HSEP:14-F09	00
10	Inspection on Height Working	HSEP:14-F10	00
11	Inspection on Welding & Gas Cutting	HSEP:14-F11	00
12	Inspection on Electrical Installation	HSEP:14-F12	00
13	Inspection on Elevator	HSEP:14-F13	00
14	HSE Penalty	HSEP:14-F14	00
15	Accident /incident / property damage /fire incident report	HSEP:14-F15	00



**HEALTH, SAFETY AND ENVIRONMENT  
PLAN FOR  
SITE OPERATION by SUBCONTRACTORS**

Doc no.: HSEP: 14

REV: 01

Date: 20.01.2020

POWER SECTOR

Page: 36 of 43

**20.0 ANNEXURES**

**ANNEXURE 01**

**As per Contract Labour (Regulation & Abolition Act), Central Rules, 1971,**

- (1) The first-aid box shall be distinctively marked with a Red Cross on a white background and shall contain the following items, namely:

**(a) For establishments in which the number of contract labour employed does not exceed fifty, each first aid box shall contain the following equipment:**

(i)	6 small sterilized dressings
(ii)	3 medium size sterilized dressings
(iii)	3 large size sterilized dressings
(iv)	6 pieces of sterilized eye pads in separate sealed packets.
(v)	6 roller bandages 10 cm wide.
(vi)	6 roller bandages 5 cm wide.
(vii)	One tourniquet
(viii)	A supply of suitable splints
(ix)	Three packets of safety pins.
(x)	Kidney tray.
(xi)	3 large sterilized burn dressings.
(xii)	1 (30ml) bottle containing a two percent alcoholic solution of iodine
(xiii)	1 (30 ml) bottle containing Sal volatile having the dose and mode of administration indicated on the label
(xiv)	1 snake bite lancet
(xv)	1 (30gms) bottle of potassium permanganate crystals.
(xvi)	1 pair scissors
(xvii)	1 copy of the First-Aid leaflet issued by the Director General, Factory Advice Service and Labour Institutes, Government of India.
(xviii)	A bottle containing 100 tablets (each of 5 grains) of aspirin
(xix)	Ointment for burns
(xx)	A bottle of suitable surgical anti-septic solution

**(b) For establishment in which the number of contract labour exceeds fifty each first-aid box shall contain the following equipment:**

(i)	12 small sterilized dressings
(ii)	6 medium size sterilized dressings
(iii)	6 large size sterilized dressings.
(iv)	6 large size sterilized burn dressings
(v)	6 (15 grams) packets sterilized cotton wool
(vi)	12 pieces of sterilized eye pads in separate sealed packets.



**HEALTH, SAFETY AND ENVIRONMENT  
PLAN FOR  
SITE OPERATION by SUBCONTRACTORS**

Doc no.: HSEP: 14

REV: 01

Date: 20.01.2020

POWER SECTOR

Page: 37 of 43

(vii)	12 roller bandages 10 cm wide.
(viii)	12 roller bandages 5 cm wide.
(ix)	One tourniquet.
(x)	A supply of suitable splints.
(xi)	Three packets of safety pins.
(xii)	Kidney tray.
(xiii)	Sufficient number of eye washes bottles filled with distilled water or suitable liquid clearly indicated by a distinctive sign which shall be visible at all times.
(xiv)	4 per cent Xylocaine eye drops, and boric acid eye drops and soda by carbonate eye drops.
(xv)	1 (60ml) bottle containing a two percent alcoholic solution of iodine
(xvi)	One (two hundred ml) bottle of mercurochrome (2 per cent) solution in water.
(xvii)	1 (120ml) bottle containing Sal volatile having the dose and mode of administration indicated on the label.
(xviii)	1 roll of adhesive plaster (6 cmX1 meter)
(xix)	2 rolls of adhesive plaster (2 cmX1 meter)
(xx)	A snake bite lancet.
(xxi)	1 (30 grams) bottle of potassium permanganate crystals.
(xxii)	1 pair scissors
(xxiii)	1 copy of the First-Aid leaflet issued by the Director-General, Factory Advice service and labour Institutes, Government of India.
(xxiv)	a bottle containing 100 tablets (each of 5 grains) of aspirin
(xxv)	Ointment for burns
(xxvi)	A bottle of a suitable surgical anti septic solution.

(2) Adequate arrangement shall be made for immediate recoupment of the equipment when necessary.



**HEALTH, SAFETY AND ENVIRONMENT  
PLAN FOR  
SITE OPERATION by SUBCONTRACTORS**

Doc no.: HSEP: 14

REV: 01

Date: 20.01.2020

POWER SECTOR

Page: 38 of 43

**ANNEXURE 02**

**HSE AUDIT/INSPECTION CHECKLIST CUM COMPLIANCE REPORT**

PROJECT: \_\_\_\_\_

SUBCONTRACTOR: \_\_\_\_\_

DATE : \_\_\_\_\_

OWNER : \_\_\_\_\_

INSPECTION BY: \_\_\_\_\_

Note : write 'NA' wherever the items is not applicable

Item	Y e s	N o	Remarks	Action
<b>HOUSEKEEPING</b>				
Waste containers provided and used				
Passageways and walkways clear				
General neatness of working area				
Other				
<b>PERSONNEL PROTECTIVE EQUIPMENTS</b>				
Goggles; shields				
Face protection				
Hearing protection				
Respiratory masks etc.				
Safety belts				
Other				
<b>EXCAVATIONS / OPENINGS</b>				
Openings properly covered or barricaded				
Excavations shored				
Excavations barricaded				
Overnight lighting provided				
Other				
<b>WELDING, CUTTING</b>				
Gas cylinders chained upright				
Cable and hoses not obstructing				
Fire extinguisher (s) accessible				
Others				
<b>SCAFFOLDING</b>				
Fully decked platforms				
Guard and intermediate rails in place				
Toe boards in place				
Adequate shoring				
Adequate access				
Others				
<b>LADDER</b>				
Extension side rails 1 m above				
Top of landing				
Properly secured				



**HEALTH, SAFETY AND ENVIRONMENT  
PLAN FOR  
SITE OPERATION by SUBCONTRACTORS**

Doc no.: HSEP: 14

REV: 01

Date: 20.01.2020

POWER SECTOR

Page: 39 of 43

Angle + 70° from horizontal				
Other				
<b>HOISTS, CRANES AND DERRICKS</b>				
Condition of cables and sheaf OK				
Condition of slings, chains, hooks OK				
Inspection & maintenance log maintained				
Outriggers used				
Signals observed and understood				
Qualified operators				
Others				
<b>MACHINERY, TOOLS &amp; EQUIPMENT</b>				
Proper instruction				
Safety devices				
Proper cords				
Inspection and maintenance				
Other				
<b>VEHICLE AND TRAFFIC</b>				
Rules and regulations observed				
Inspection and maintenance				
Licensed drivers				
Other				
<b>TEMPORARY FACILITIES</b>				
Emergency instructions posted				
Fire extinguishers provided				
Fire-aid equipment available				
General neatness				
Others				
<b>FIRE PREVENTION</b>				
Personnel instructed				
Fire extinguishers checked				
No smoking in prohibited areas.				
Hydrants				
Clearance				
Others				
<b>ELECTRICAL</b>				
Proper wiring				
ELCB's provided				
Ground fault circuit interrupters				
Protection against damage				
Prevention of tripping hazards				
Other				
<b>HANDLING &amp; STORAGE OF MATERIALS</b>				
Properly stored or stacked				
Passageways clear				
Other				
<b>FLAMMABLE GASES AND LIQUIDS</b>				
Containers clearly identified				
Proper storage				
Fire extinguisher nearby				



**HEALTH, SAFETY AND ENVIRONMENT  
PLAN FOR  
SITE OPERATION by SUBCONTRACTORS**

Doc no.: HSEP: 14

REV: 01

Date: 20.01.2020

Page: **40 of 43**

POWER SECTOR

Other				
<b>WORKING AT HEIGHT</b>				
Safety nets				
Safety belts				
Safety helmets				
Anchoring of safety belt to the life line rope				
<b>ENVIRONMENT</b>				
Lubricant waste/engine oils properly dispose.				
Waste from Canteen, offices, sanitation etc. disposed properly.				
Disposal of surplus earth, stripping materials, expired batteries, oily rags and combustible materials done properly.				
<b>HEALTH CHECKS</b>				
Hygienic conditions at labor camps O.K.				
Availability of first-aid facilities				
Proper sanitation at site, office & labor camps.				
Arrangement of medical facilities.				
Measures for dealing with illness.				
Availability of potable drinking water for workmen & staff.				
Provision of crèches for children.				



**HEALTH, SAFETY AND ENVIRONMENT  
PLAN FOR  
SITE OPERATION by SUBCONTRACTORS**

Doc no.: HSEP: 14

REV: 01

POWER SECTOR

Date: 20.01.2020

Page: 41 of 43

**ANNEXURE 03**

**REFERENCES**

- Contract documents
- Relevant legislations
- HSEMSM
- Relevant Indian standards as listed below (illustrative only):

SL NO	CODE NAME	TITLE
(1)	IS : 818-1888 (Reaffirmed 2003)	Code of Practice for safety and health requirements in Electric and Gas Welding and Cutting operations.
(2)	IS: 1179-1967 (Reaffirmed 2003)	Specification for Equipment for Eye & Face protection during welding.
(3)	IS : 1989 (Part 2):1986 (Reaffirmed 1997)	Specification for Leather Safety Boots & Shoes
(4)	IS:2925 – 1984 (Reaffirmed 2010)	Specification for Industrial Safety Helmets
(5)	IS:3521 : 1999 (Reaffirmed 2002)	Industrial Safety Belts & Harnesses-Specification
(6)	IS:3646(Part II) – 1966 (Reaffirmed 2003)	Code of Practice for Interior Illumination
(7)	IS:3696 (Part I) – 1987 (Reaffirmed 2002)	Safety Code for Scaffolds and Ladders
(8)	IS: 3696(Part 2) : 1991 (Reaffirmed 2002 )	Scaffolds and Ladders-Code of Safety
(9)	IS:3786 – 1983 (Reaffirmed 2002)	Method for Computation of Frequency and Severity Rates for Industrial Injuries and Classification of Industrial Incidents
(10)	IS:4770 : 1991 (Reaffirmed 2006)	Rubber Gloves – Electricals purposes-Specification
(11)	IS:4912 : 1978 (Reaffirmed 2002)	Safety Requirements for Floor and Wall Openings, Railings and Toe Boards
(12)	IS: 5983 – 1980 (Reaffirmed 2002)	Specification for Eye-Protectors
(13)	IS:6519 – 1971 (Reaffirmed 1997)	Code of Practice for Selection, Care and Repair of Safety Footwear
(14)	IS:9167:1979	Specification for Ear-Protectors
(15)	IS:6994(Part I)-1973 (Re affirmed 1996)	Specification for Industrial Safety Gloves Leather and Cotton Gloves
(16)	IS:8519 – 1977 (Reaffirmed 1983)	Guide for Selection of Industrial Safety Equipment for Body Protection.
(17)	IS 11006 : 2011	Flash Back(Flame Arrestor) Specification



**HEALTH, SAFETY AND ENVIRONMENT  
PLAN FOR  
SITE OPERATION by SUBCONTRACTORS**

Doc no.: HSEP: 14

REV: 01

Date: 20.01.2020

POWER SECTOR

Page: **42 of 43**

(18)	IS:8520 – 1977 (Reaffirmed 2002)	Guide for Selection of Industrial Safety Equipment for Eye, Face and Ear Protection.
(19)	IS:9473:2002	Respiratory Protective Devices-Filtering Half Masks to protect against Particles-Specification.
(20)	IS:9944:1992 (Reaffirmed 2003)	Natural and Man-made Fiber Rope Slings-Recommendations on Safe working loads.
(21)	IS:11057 – 1884 (Reaffirmed 2001)	Specification for Industrial Safety Nets
(22)	IS:12254:1993 (Reaffirmed 2002)	Polyvinyl Chloride (PVC) Industrial Boots-Specification
(23)	IS:13367(Part 1):1992 (Reaffirmed 20030)	Safe Use of Cranes-Code of Practice
(24)	IS:14166:1994 (Reaffirmed 2002)	Respiratory Protective Devices-Full Face Masks Specification
(25)	IS:14746 : 1999 (Reaffirmed 2003)	Respiratory Protective Devices-Half Masks and Quarter Masks - Specification
(26)	IS : 15397 :2003 (Reaffirmed 2008)	Portable Extinguisher Mechanical Foam Type(Stored Pressure)-Specification
(27)	IS: 19011:2002	Guidelines for Quality and/or Environmental Management Systems Auditing



**HEALTH, SAFETY AND ENVIRONMENT  
PLAN FOR  
SITE OPERATION by SUBCONTRACTORS**

Doc no.: HSEP: 14

REV: 01

Date: 20.01.2020

POWER SECTOR

Page: **43 of 43**

**ANNEXURE 04 : SAFETY FORMATS  
&  
ANNEXURE 05 : WORK PERMIT FORMATS**

**POWER SECTOR****INSPECTION OF FIRST AID BOX**

FORMAT NO: HSEP:14-F01

REV NO.: 00

PAGE NO. 01 OF 02

<b>Name of Site :</b>	
<b>Name of Sub-Contractor :</b>	
<b>Inspected by :</b>	
<b>Date of Inspection :</b>	

Number of employees on the site: - \_\_\_\_\_

Sl.No.	Item	No. Available	Remarks
1	No. of small sterilized dressings		
2	No of medium sized sterilized dressings		
3	No of large sized sterilized dressings.		
4	No of large sized sterilized burn dressings		
5	No of (15 grams) packets sterilized cotton wool		
6	No of pieces of sterilized eye pads in separate sealed packets.		
7	No of roller bandages 10 cm wide.		
8	No of roller bandages 5 cm wide.		
9	Whether tourniquet available		
10	Whether supply of Suitable splints available.		
11	No of packets of safety pins.		
12	Whether kidney tray available		
13	Whether sufficient number of eye wash bottles, filled with distilled water or suitable liquid, clearly indicated by a distinctive sign which shall be visible at all times, available.		
14	Whether 4%-xylocaine eye drops, and boric acid eye drops and soda by carbonate eye drops available.		
15	Whether (60ml) bottle containing a two percent alcoholic solution of iodine available		
16	Whether (two hundred ml) bottle of mercurochrome (2 per cent) solution in water available.		

**POWER SECTOR****INSPECTION OF FIRST AID BOX**

FORMAT NO: HSEP:14-F01

REV NO.: 00

PAGE NO. 02 OF 02

Sl.No.	Item	No. Available	Remarks
17	Whether 120ml bottle containing Sal volatile having the dose and mode of administration indicated on the label, available.		
18	Whether roll of adhesive plaster (6 cmX1 meter) available		
19	No of rolls of adhesive plaster (2 cmX1 meter)		
20	Whether snake bite lancet available.		
21	Whether (30 grams) bottle of potassium permanganate crystals available.		
22	Whether a pair scissors available		
23	Whether copy of the First-Aid leaflet issued by the Director-General, Factory Advice service and labour Institutes, Government of India available.		
24	Whether bottle containing 100 tablets (each of 5 grains) of aspirin available		
25	Whether Ointment for burns available		
26	Whether bottle of a suitable surgical anti-septic solution available		

Signature of Subcontractor's Site I/C:

**POWER SECTOR****HEALTH CHECK UP**

FORMAT NO: HSEP:14-F02

REV NO.: 00

PAGE NO. 1 OF 02

<b>Name of Site :</b>	
<b>Name of Sub-Contractor :</b>	
<b>Name of Employee :</b>	

**NAME:**

History Of Past Illness	H/O Epilepsy
	H/O Drug Allergy
	H/O Diabetics/ Hypertension
	H/O Unconsciousness

Personal History

<b>EXAMINATION</b>		<b>OBSERVATION</b>	
<b><u>General Physical Examination</u></b>			
Height	:		
Weight	:		
BMI	:		
Built And nourishment	:		
Pallor	:		
Temperature	:		
Chest Expansion	:	Inspiration	Expansion
Lymph Node Enlargement	:		
<b><u>Ear, Nose, Throat</u></b>	:		
Ear	:		
Nose	:		
Throat	:		

**POWER SECTOR****HEALTH CHECK UP**

FORMAT NO: HSEP:14-F02

REV NO.: 00

PAGE NO. 2 OF 02

EXAMINATION	OBSERVATION
<b><u>Cardiovascular System Examination</u></b> :	
Inspection :	
Palpation :	Pulse BP
Auscultation (Heart Sounds) :	
<b><u>Respiratory System</u></b> :	
Inspection :	Respiratory Rate
Palpation:	
Percussion :	
Auscultation (Breath Sounds) :	
<b><u>Examination of Abdomen</u></b> :	
Inspection :	
Palpation :	
Auscultation (Bowel Sounds) :	
<b>Any Other</b> :	
<b>Clinical Impression</b>	

Signature of the examining doctor





**POWER SECTOR****PERSONAL PROTECTIVE EQUIPMENTS**

FORMAT NO: HSEP:14-F06

REV NO.: 00

PAGE NO. 01 OF 01

<b>Name of Site :</b>	
<b>Name of Sub-Contractor :</b>	
<b>Inspected by :</b>	
<b>Date of Inspection :</b>	

<b>Item</b>	<b>Issued this Month</b>	<b>Nos. Issued up to the Month</b>	<b>Percentage of usage at site</b>
Safety Helmet			
Safety Shoes			
Full Body Harness			
Fall Arrestor			
Safety Nets			
Other PPEs.			

Signature of Site I/C of Subcontractor :

**POWER SECTOR****INSPECTION OF T&Ps**

FORMAT NO: HSEP:14-F07

REV NO.: 00

PAGE NO. 01 OF 01

<b>Name of Site :</b>	
<b>Name of Sub-Contractor :</b>	
<b>Date of Inspection :</b>	

Sl.No.	Description	Remarks
1.0	Name of equipment	
2.0	Basic Information of equipment	
2.1	Specification	
2.2	Sr. No. of equipment	
2.3	Make	
2.4	Year of manufacture	
3.0	Major repairs / overhauls(Furnish details of work carried out)	Date(s) of major repair/overhaul
3.1		
3.2		
3.3	Repairs carried out at site	
4.0	Any performance test conducted	Yes/No
5.0	Document Submitted	Yes/No
6.0	Manufacturer's test / guarantee certificate	Available/ Not available
7.0	Performance test	Done/ Not Done
8.0	Acceptance Norms	
9.0	Committee Observations	
10.0	Date of next review (if accepted)	

Signature-Site Safety Officer ( BHEL)

Signature-Subcontractor/ Subcontractor's  
Safety Officer

**POWER SECTOR****STATUS OF T&Ps**

FORMAT NO: HSEP:14-F08

REV NO.: 00

PAGE NO. 01 OF 01

Name of Site	
Name of Sub-Contractor	
Date of Inspection	

Item	Nos. Deployed	Identification No.	Nos. Tested by competent person	Validity of Test Certificate
Winches				
Chain Blocks				
Wire Rope Slings				
Man Cages				
D-Shackles				
Air Compressors				
Crawler Cranes				
Mobile Cranes				
Hydra Cranes				
Others				

Signature of Site I/C of subcontractor:

**POWER SECTOR****INSPECTION OF CRANES AND WINCHES**

FORMAT NO: HSEP:14-F09

REV NO.: 00

PAGE NO. 01 OF 03

<b>Name of Site :</b>	
<b>Name of Sub-Contractor :</b>	
<b>Inspected by :</b>	
<b>Date of Inspection:</b>	

**Crane Reg. No (Make/Model)** \_\_\_\_\_**Name of Driver/Operator** \_\_\_\_\_

Sl.no.	Description	Observation	Measures
1	Valid Driving license		
2	Hook & Hook Latch		
3	Over Hoist limit switch		
4	Boom limit switch		
5	Boom Angle Indicator		
6	Boom limit cutoff switch		
7	Condition of Boom		
8	Condition of ropes		
9	Number of load lines		
10	Size and condition of the slings		
11	Stability of the cranes		
12	Soil Condition		
13	Swing Break And Lock		
14	Proper Break And Lock		
15	Hoist Break And Lock		
16	Boom Break And Lock		
17	Main Clutch		
18	Leakage in Hydraulic Cylinders		
19	Out riggers fully extendable		
20	Tyre pressure		
21	Condition of Battery And Lamps		

**POWER SECTOR****INSPECTION OF CRANES AND WINCHES**

FORMAT NO: HSEP:14-F09

REV NO.: 00

PAGE NO. 2 OF 03

Sl.no.	Description	Observation	Measures
22	Guards of moving and rotating parts		
23	Load chart provided		
24	Number and position of pedant ropes		
25	Reverse Horn		
26	Load Test Details		
27	Operator's fitness		
28	Pollution under control certificate		
29	Fire extinguisher of appropriate type.		
30	Training of the operator		

**WINCH**

Sl. No.	Description	YES	NO	NA	Remarks
1	Has the copy of Third Party Inspection certificate been provided in winch machine shed?				
2	Is winch machine operator experienced enough to operate the winch machine?				
3	Is the winch machine operated by someone other than the winch machine operator?				
4	Is there guard provided in all moving parts like wheel and motor's shaft?				
5	Will it protect against unforeseen operational contingencies?				
6	Are brakes, clutch and locking arrangement working properly?				
7	Has it been ensured that the guard does not constitute a hazard by itself?				
8	Are the cranks and the connecting rods protected by guardrails?				
9	Is there provision for fully covered shed with wooden plank roof?				

**POWER SECTOR****INSPECTION OF CRANES AND WINCHES**

FORMAT NO: HSEP:14-F09

REV NO.: 00

PAGE NO. 3 OF 03

Sl. No.	Description	YES	NO	NA	Remarks
10	Is wire rope free from any kind of damage or wear and tear?				
11	Is split pin provided for the protection of clutch and brake locking arrangement?				
12	Is pulley inspected by competent person and certified before use?				
13	Is pulley free from any wear and tear visually?				
14	Is winch rope barricaded with clipsheet for the protection of rope and person?				
15	Is the wire rope lubricated by cardium oil?				
16	Is there any friction in wire rope which may damage the wire rope rather than the rolling parts?				
17	Is there any oil leakage in the hydraulic system of the winch machine?				
18	Has it been ensured that the guard will not cause discomfort or inconvenience to operator?				
	<b>Total Number of NO:</b>				
	<b>Total Number of NA:</b>				
	<b>% Compliance :</b>				

Signature of Site I/C of subcontractor :

**POWER SECTOR****INSPECTION OF HEIGHT WORKING**

FORMAT NO: HSEP:14-F10

REV NO.: 00

PAGE NO. 01 OF 02

<b>Name of Site :</b>	
<b>Name of Sub-Contractor :</b>	
<b>Inspected by :</b>	
<b>Date of Inspection:</b>	

Sl. No.	Descriptions	Observation (Yes/No)	Remarks
1	All the workers have been explained safe work method?		
2	An established communication system has been established and explained to the workers.		
3	Adequate illumination has been ensured.		
4	Work area inspected prior to the start of the work.		
5	Area below the work place barricaded, particularly below hot work.		
6	Workers provided with bags /box to carry bolts, nuts and hand tools		
7	Arrangement for fastening hand tools made.		
8	All work platforms ensured to be of adequate strength and ergonomically suitable.		
9	Fabricated makeshift arrangements are checked for quality and type of material welding, anchoring etc.		
10.	Work at more than one elevation at the same segment is restricted.		
	<b>ACCESS/EGRESS</b>		
1	Walkways provided with handrail, mid-rail and toe guard?		
2	All checkered plates, gratings properly welded/ bolted?		
3	Are ladders inspected and they are in good condition?		
4	Are ladders spliced?		
5	Are ladders properly secured to prevent slipping, sliding or falling?		
6	Do side rails extend 36" above top landing?		
7	Are built up ladders constructed of sound materials?		

**POWER SECTOR****INSPECTION OF HEIGHT WORKING**

FORMAT NO: HSEP:14-F10

REV NO.: 00

PAGE NO. 02 OF 02

Sl. No.	Descriptions	Observation (Yes/No)	Remarks
8	Are rugs and cleats not over 12" on center?		
9	Metal ladders not used around electrical hazards.		
10	Proper maintenance and storage.		
11	Ladders placed at right slope.		
12	Ladders / staircases welded/ bolted properly.		
13	Any obstruction in the stairs.		
14	Are landing provided with handrails, knee rails, toe boards etc.?		
15	Whether ramp is provided with proper slope.		
16	Proper hand rails / guards provided in ramps.		
	<b>Housekeeping</b>		
1	Walkways, aisles & all overhead workplaces cleared of loose material.		
2	Flammable materials, if any, are cleared.		
3	All the de shuttering materials are removed after de shuttering is done.		
4	Platforms and walkways free from oil/grease or other slippery material.		
5	Collected scrap are brought down or lowered down and not dropped from height.		
	<b>PPE And Safety Devices</b>		
1	Use of safety helmet, safety belts ensured for all workers		
2	Anchoring points provided at all places of work.		
3	Common lifeline provided wherever linear movement at height is required.		
4	Safety nets are use wherever required.		
5	Proper fall arrest system is deployed at critical workplaces.		
6	Crawler boards/Safety system or works on fragile roof are used.		

Signature of Site I/C of subcontractor :

**POWER SECTOR****INSPECTION OF WELDING AND GAS  
CUTTING**

FORMAT NO: HSEP:14-F11

REV NO.: 00

PAGE NO. 1 OF 02

<b>Name of Site</b>	
<b>Name of Sub-Contractor</b>	
<b>Inspected by</b>	
<b>Date of Inspection</b>	

<b>Welding</b>				
Sl.no.	Description	Y e s	N o	Remarks
1	Is electric connection given through 30 mA ELCB/RCCB to welding m/c?			
2	Is electric cable fitted properly in junction box on m/c?			
3	Is electrical cable free from joints?			
4	Are the joints attached firmly & insulated with tape?			
5	Is double earthing given to body of m/c?			
6	Is the physical condition of the m/c good?			
7	Is ON/OFF switch connected to the m/c is working and in good condition?			
8	Are indication lamps on m/c working?			
9	Is the electrode holder in good condition?			
10	Are the cables of the welding m/c lugged & tight properly?			
11	Are return lead connected properly (Rod, Angle, Channels shall not be used)			
	Total No of NO			
	Total No of YES			

**POWER SECTOR****INSPECTION OF WELDING AND GAS  
CUTTING**

FORMAT NO: HSEP:14-F11

REV NO.: 00

PAGE NO. 2 OF 02

Gas Cutting				
Sl. no	Description	Yes	No	Remarks
1	Are Cylinders kept on trolleys?			
2	Physical condition of Gas cylinders Good?			
3	Is there Oil/Grease on valve of the cylinder?			
4	Are pressure regulators in good condition?			
5	Condition of hose pipe OK?			
6	Are hose pipe clamped with hose clip?			
7	Is flash back arrestor & NRV fitted on torch both for O2 and LPG cylinder?			
8	Is nozzle of the torch cleaned?			
	Total Number of NO			
	Total No of YES			
	<b>% Compliance</b>			

Signature of Site I/C of subcontractor :

	<b>POWER SECTOR</b>	FORMAT NO: HSEP:14-F12 REV NO.: 00 PAGE NO. 01 OF 02
	<b>INSPECTION OF ELECTRICAL INSTALLATION</b>	

<b>Name of Site</b>	
<b>Name of Sub-Contractor</b>	
<b>Inspected by</b>	
<b>Date of Inspection:</b>	

Sr. No.	Contents	Yes/No	Remarks
<b>A</b>	<b>Cable</b>		
1.	Whether the condition of cable is checked?		
2.	Are cables received from other sites checked for insulation resistance before putting them into use?		
3.	Are all main cables taken either underground / overhead?		
4.	Are welding cables routed properly above the ground?		
5.	Are welding and electrical cables overlapping?		
6.	Is any improper joining of cables/wires prevailing at site?		
<b>B</b>	<b>DBs/SDBs</b>		
1.	Is earth conductor continued up to DB / SDB?		
2.	Whether DBs and extension boards are protected from rain / water?		
3.	Is there any overloading of DBs / SDBs?		
4.	Are correct / proper fuses & CBs provided at main boards and sub-boards?		
5.	Is energized wiring in junction boxes, CB panels & similar places covered all times?		
<b>C</b>	<b>ELCB</b>		
1.	Whether the connections are routed through ELCB?		
2.	Is ELCB sensitivity maintained at 30 mA?		

**POWER SECTOR****INSPECTION OF ELECTRICAL INSTALLATION**

FORMAT NO: HSEP:14-F12

REV NO.: 00

PAGE NO. 02 OF 02

Sr. No.	Contents	Yes/No	Remarks
3.	Are the ELCB numbered and tested periodically & test results recorded in a logbook countersigned by a competent person?		
<b>D</b>	<b>Grounding</b>		
1.	Is natural earthing ensured at the source of power (main DB at Generator or Transformer)?		
2.	Whether the continuity and tightness of the earth conductor are checked?		
3.	Mention the gauge of the earth conductor used at the site.		
4.	Mention the value of Earth Resistance.		
<b>E</b>	<b>Electrically operated Machines or Accessories.</b>		
1.	Whether the plug top is provided everywhere.		
2.	Are all metal parts of electrical equipment and light fittings / accessories grounded?		
3.	Is there any shed or cover for welding machines?		
4.	Are halogen lamps fixed at proper places?		
5.	Are portable power tools maintained as per norms?		
6.	Any other information:		

Signature of Site I/C of subcontractor :



**POWER SECTOR**

**INSPECTION OF ELEVATOR**

FORMAT NO: HSEP:14-F13  
REV NO.: 00  
PAGE NO. 01 OF 01

<b>Name of Site</b>	
<b>Name of Sub-Contractor</b>	
<b>Inspected by</b>	
<b>Date of Inspection</b>	

Sr. No.	Description	Remarks
1.0	Name of equipment	
2.0	Basic Information of equipment	
2.1	Specification	
2.2	Sr. No. of equipment	
2.3	Make	
2.4	Year of manufacture	
3.0	Major repairs/overhauls(Furnish details of work carried out)	Date(s) of major repair/overhaul
3.1		
3.2		
3.3	Repairs carried out at site	
4.0	Any performance test conducted	Yes/No
5.0	Document Submitted	Yes/No
6.0	Manufacturer's test / guarantee certificate	Available/ Not available
7.0	Performance test	Done/ Not Done
8.0	Acceptance Norms	
9.0	Committee Observations	
10.0	Date of next review (if accepted)	

<b>Signature-Subcontractor/ Subcontractor's Safety Officer</b>	<b>Signature-Site Safety Officer ( BHEL)</b>
--	--

**POWER SECTOR****Inspection of Excavation**

FORMAT NO: HSEP:14-F13E

REV NO.: 00

PAGE NO. 01 OF 01

<b>Name of Site :</b>	
<b>Name of Sub-Contractor :</b>	
<b>Inspected by :</b>	
<b>Date of Inspection :</b>	

Sl.no.	Description	Yes	No	Remarks
1	Precautions taken for Underground Electrical Cable			
2	Precautions taken for Under / Above ground sewer/ Drinking Water Line			
3	Precautions taken for Underground Telecommunication Line			
4	Precautions taken for Underground Product/Utility Line			
5	Precautions taken for Underground Fire Water Line			
6	Shoring / Shuttering / Sheet piling done to prevent collapse of excavation walls. Strength of Excavation wall ensured at all times			
7	Slope Cutting / Angle Maintained			
8	Hard Barricading & Edge Protection provided			
9	Separate Safe Access for Man and Vehicle			
10	Lighting arrangement			
11	Banksman Provided			
12	Required basic PPEs provided			
13	Excavated soil / Construction Material / equipment kept away from the edge.			
14	First aid in attendance.			
15	Other:			
	Total No of YES			

Signature-Subcontractor/ Subcontractor's Safety Officer

Signature-Site Safety Officer ( BHEL)

**POWER SECTOR****HSE PENALTY**

FORMAT NO: HSEP:14-F14

REV NO.: 00

PAGE NO. 1 OF 02

**Sub: MEMO for Penalty for non-compliances in Safety**

Following lapse (tick marked) was observed and penalty is imposed as stated at the bottom of this memo. It is requested that such occurrences be please avoided in future.

**Safety Area**

SN	Violation of Safety Norms	Fine (in Rs)
01	Not Wearing Safety Helmet	200/- *
02.	Not wearing Safety Belt or not anchoring life line	500/-*
03	Not wearing safety shoe	200/-*
04	Not keeping gas cylinders vertically	200/-
05	Not using flash back arrestors	100/-
06	Not wearing gloves	50/- *
07.	Grinding Without Goggles	50/- *
08.	Not using 24 V Supply For Internal Work	500/-
09.	Electrical Plugs Not used for hand Machine	100/-
10.	Not Slinging properly	200/-
11.	Using Damaged Sling	200/-
12.	Lifting Cylinders Without Cage	500/-
13.	Not Using Proper Welding Cable With Lot of Joints And Not Insulated Property.	200/-
14.	Not Removing Small Scrap From Platforms	500/-
15.	Gas Cutting Without Taking Proper Precaution or Not Using Sheet Below Gas Cutting	500/-
16.	Not Maintaining Electric Winches Which are Operated Dangerously	500/-
17.	Improper Earthing Of Electrical T&P	500/-
18	No or improper barricading	500/-
19.	Activity carried out without Safety work permit (Height work, Lifting activity, Hot work-each person/case)	1000/-
20.	Incident Resulting in Partial Loss in Earning Capacity	25,000/- per victim
21.	Fatal Incident Resulting in total loss in Earning Capacity	1,00,000/- per victim for first instance #

**Legend: -**

\*: per head. For repeated violation by the same person, the penalty would be double of the previous penalty. Date of "Repeated violation" will be counted from subsequent days.

#: or as deducted by customer, whichever is higher. For repeated fatal incident in the same Unit incremental penalty to be imposed. The subcontractor will pay 2 times the penalty compared to previously paid in case there are repeated cases of fatal incidents under the same subcontractor for the same package in the same unit.



**POWER SECTOR**

**HSE PENALTY**

FORMAT NO: HSEP:14-F14

REV NO.: 00

PAGE NO. 2 OF 02

Details (if any) related to non- compliance (Name of persons, Nature of deficiency, etc.)

\_\_\_\_\_

Penalty imposed:

1, Rate as per above chart \_\_\_\_\_

2. No. of Persons/ machine/ event/ labour \_\_\_\_\_

3. Total Penalty= 1. X 2. = \_\_\_\_\_

Signature:

Witnessed by: (Sub- Contractor representative) (BHEL Personnel)

Name \_\_\_\_\_

Name \_\_\_\_\_

Distribution: 1 Copy: to Sub- contractor,  
1 Copy to Site Construction Manager (BHEL)



**POWER SECTOR- HQ**

**Incident Report**

(To be submitted within 24 hours of time of incident)

FORMAT NO: HSEP:14-F15

REV NO.: 00

PAGE NO. 01 OF 01

**Type of incident: Fatal/Major/ Minor/Fire/Property Damage/Near-miss**

1	NAME OF SITE		3	ACTIVITY AREA	
2	SCOPE OF WORK		4	NAME OF CONTRACTOR	
			5	NAME & DESIGNATION OF BHEL ACTIVITY I/C	
6	DATE & TIME OF ACCIDENT		7	DATE RESUMED	
8	NO. OF WORK-DAYS LOST BY VICTIM (If duty not resumed, give estimated figure)				
9	NO. OF MANHOURS LOST BY OTHERS				
10	PERSONAL DETAILS OF INJURED AND / OR DETAILS OF MATERIALS / EQUIPMENT / PROPERTY DAMAGED				
NAME			NAME OF MATERIAL / EQUIPMENT / PROPERTY		
PERIOD OF EMPLOYMENT					
AGE	YRS	SEX	MALE/ FEMALE	ESTIMATED COST	ACTUAL COST
MARITAL STATUS		SINGLE / MARRIED			
OCCUPATION			NATURE OF DAMAGE		
PART OF BODY INJURED					
NATURE OF INJURY					
AGENCY ( OBJECT / EQUIPMENT / SUBSTANCE ) MOST RESPONSIBLE FOR CAUSING ACCIDENT / INJURY / DAMAGE					
12	PERSON (NAME & DESIGNATION) WITH MOST CONTROL OVER AGENCY (OBJECT / EQUIPMENT / SUBSTANCE ) CAUSING ACCIDENT INJURY / DAMAGE				
13	DESCRIBE CLEARLY HOW THE ACCIDENT OCCURRED (USE ADDITIONAL SHEET, IF REQUIRED)				
<b>ANALYSIS</b>					
14	WHAT ACTS AND / OR CONDITIONS CONTRIBUTED MOST DIRECTLY TO THIS ACCIDENT				
15	WHAT ARE THE BASIC REASON FOR THE EXISTENCE OF THESE ACTS AND / OR CONDITION ?				
16	WHAT CORRECTIVE ACTIONS HAVE BEEN TAKEN TO PREVENT ACCIDENT RECURRENCE ?				
	DATE :		SIGNATURE OF SITE HSE COORDINATOR		
17	COMMENTS OF HEAD / SOX				
	DATE:		SIGNATURE OF HEAD/SOX		



## POWER SECTOR

### Format for Monthly HSE Planning & Review

FORMAT NO: HSEP:14-F30

REV NO.: 00

PAGE NO. 01 OF 3

**Note: This is a template and can be modified in consultation with BHEL**

Name of the Site		Name of the Subcontractor	
Scope of Work		Date	
<b>PART- A: PLAN OF HSE ACTIVITIES FOR THE MONTH OF.....</b>			<b>PART-B: REVIEW ON .....</b>
SN.	Description of HSE Activity & Formats	Plan & Targets for the month	Review
1	Availability of First Aid Box at Required Places and Inspection thereof as per Format: Fo1	Areas 1. ... ...	
2	Health check-up as per Format: Fo2	Health check-up for Nos 1. New inductees 2. Drivers & Operators 3. Workers in following high risk areas: a. ...	
3	Induction training of newly joined workers as per Format: Fo3	Minimum No. of workers:	
4	Toolbox talks (TBT) conducted before start of work as per Format: Fo4	Locations of TBTs & No. of workers <b>1.</b> ...	
5	PPE usage and issue as per Format: Fo6		
6	Inspection of T&Ps as per Format: Fo7	List of T&Ps to be inspected 1.	
7	Identification & Inspection Status of T&Ps as per Format: Fo8		
8	Inspection of Cranes & Winches as per Format: Fo9	List of Cranes & Winches & Nos. 1. ...	
9	Inspection of Height Working as per Format: F10	Areas: 1. ...	
10	Inspection of Welding & Gas Cutting operations as per Format: F11	Areas: 1. ...	
11	Inspection of Electrical Installations as per Format: F12	Locations: 1. ...	
12	Inspection of Elevators (as applicable) as per Format: F13	Locations: 1. ...	
13	Inspection of Excavation as per Format: F13E	<b>Locations:</b> <b>1.</b> ...	



## POWER SECTOR

### Format for Monthly HSE Planning & Review

FORMAT NO: HSEP:14-F30

REV NO.: 00

PAGE NO. 02 OF 3

SN.	Description of HSE Activity & Formats	Plan & Targets for the month	Review
14	Job Safety Analysis as per Format F32B	<b>Activities:</b> 1. ...	
15	Regular Job Specific Training (Re-training) for workers involved in hazardous activities	Topics/ Hazards & No. of workers 1. ...	
16	Mass housekeeping (HK) drive in work areas	Areas 1. ...	
17	Vertigo Test of Height workers	Minimum No. of workers:	
18	Deployment of qualified HSE Officers as per contract	Location(s) & Nos. 1. ...	
19	Deployment of qualified HSE Stewards as per contract	Location(s) & Nos. 1. ...	
20	Deployment of Safety tools & Equipment (Safety Nets, Lifelines, Fall arrestors, Man-cages, flashback arrestors, scaffolding etc.)	Tool/ Equipment & Location 1. ...	
21	Safety Walks by site in charge of agency (4 -Weekly once)	Dates:	
22	Safety walks by departmental head (8-Weekly twice)	Dates:	
23	Availability/ deployment of Safety posters/ placards/ signage at strategic locations	Locations: Nos. 1. ...	
24	Provision of clean drinking water sources for workers	Locations: Nos. 1. ...	
25	Provision of toilets for workers (separate for male & female workers)	Locations: Nos. 1. ...	
26	Rest sheds for workers during lunchtime, rain, dust storm etc.	Locations: Nos. 1. ...	
27	Availability of following in Labor colony	1. Clean drinking water 2. Toilets 3. Cleanliness & Hygiene 4. Grass cutting, 5. Fogging 6. Electrical Inspection ...	



**POWER SECTOR**

**Format for Monthly HSE Planning & Review**

FORMAT NO: HSEP:14-F30

REV NO.: 00

PAGE NO. 03 OF 3

SN.	Description of HSE Activity & Formats	Plan & Targets for the month	Review
28	Availability of dust/ waste bins at various locations	Locations: <b>1.</b> ...	
29	Availability of Ambulance (individual/ joint) in each shift	Ambulance No.	
30	Availability of emergency vehicle in each shift	Emergency vehicle	
31	Deployment/ Availability of tested Fire Extinguishers	Locations & Nos. <b>1.</b> ...	
32	Tree plantation	Locations & Nos. <b>1.</b> ...	
33	Waste disposal & Scrap Bins	Locations <b>1.</b> ...	
34	Illumination checks	Locations <b>1.</b> ...	
35	Safety award function: 1. Display of good practices Award presentation	Minimum 1 per month	
36	<b>Submission of Daily Reports as per Format No.F31A</b>	<b>Daily Reports (Night &amp; Day Shifts)</b>	

<b>PLAN</b>		<b>REVIEW</b>	
<b>Agency</b> Name:	<b>BHEL</b> Name:	<b>Agency</b> Name:	<b>BHEL</b> Name:
Sign:	Sign:	Sign:	Sign:
Date:	Date:	Date:	Date:





**POWER SECTOR**

**Job Safety Analysis Format**

FORMAT NO: HSEP:14-F32B

REV NO.: 00

PAGE NO. 01 OF 1

<b>Name of the Site</b>	
<b>Name of the Subcontractor</b>	
<b>Activity, Area</b>	

HAZARDS		PRECAUTIONS

(Name)	Submitted By (Agency HSE)		Reviewed By (BHEL Execution)		Approved By (BHEL HSE)	
(Sign)						
(Date)						

**POWER SECTOR- HQ**

FORMAT NO: HSEP:14-F33

REV NO.: 00

PAGE NO. 01 OF 3

**Checklist for Evaluation of HSE Performance**

SL	Parameter for Measurement	M/O	Wt	Supporting Documents
1a	Induction training for new workers conducted through audio-visual medium & documented ?	M	1	Induction Training Records
1b	Tool box talk conducted regularly as per plan, and documented?	M	1	Toolbox Talk Records
1c	Contractor in charge and safety in charge attended safety meetings?	M	2	Minutes of Meeting
1d	Whether observations in safety meetings are complied before next meeting?	M	2	-do-
1e	Preparation and submission of Monthly HSE report within stipulated time	M	1	Report submission date
1f	Preparation and submission of Incident/near-miss report and RCA Report (as applicable) within stipulated time	M	1	Incident/ Near Miss Records
1g	Carrying out Inspections and submission of Inspection reports within stipulated time	M	1	Inspection Records
1h	Regular Job Specific Training ensured for High Risk Workers (through audio-visual medium) as per plan	M	1	Training & Attendance Records
2a	Whether the contractor is registered under BOCW	M	2	BOCW Registration Certificate
2b	Availability of Qualified safety officer (1 for every 500 labour)	M	2	Safety Officer qualification & experience records
2c	Availability of Qualified safety supervisor (1 for every 100 labour )	M	2	Safety Officer qualification & experience records
2d	All the workers are provided and using safety helmets and safety shoes/gum boots	M	2	PPE Issue Records, Inspection/ non-conformity records
2e	Housekeeping done on regular basis and scrap removal at site	M	1	Housekeeping records, Inspection/ non-conformity records
2f	Usage of Goggles/Face shields and Hand gloves for gas cutter and grinders		1	PPE Issue Records, Inspection/ non-conformity records
2g	Wall openings & floor openings are guarded?		1	Inspection/ non-conformity records
2h	Adequate illumination provided in all working area?		1	Inspection/ non-conformity records
2i	Safety posters, sign boards and emergency contact numbers in all prominent location are displayed?		1	Inspection/ non-conformity records
2j	Availability of automatic reverse horns, Main horn, hook latches for Vehicles, mobile cranes, Hydras		1	Inspection/ non-conformity records
2k	Ban of carrying mobile phones to work place is implemented for workers		1	Inspection/ non-conformity records
2l	Availability of Tags & Inspection Certificates for Cranes of all capacities		1	Master T&P List with internal & external test details
2l.2	Availability of Tags & Inspection Certificates for Winches of all capacities		1	Master T&P List with internal & external test details
2l.3	Availability of Tags & Inspection Certificates, color coding for Chain pulley blocks		1	Master T&P List with internal & external test details
2l.4	Availability of Tags & Inspection Certificates for Vehicles - Trailers, Dozers, Dumpers, Excavators. Mixers etc.		1	Master T&P List with internal & external test details
2l.5	Availability of Tags & Inspection Certificates for Welding machines, grinders, Drilling machines, etc.		1	Master T&P List with internal & external test details
2l.6	Availability of Tags & Inspection Certificates, colour coding for Wire rope slings etc.		1	Master T&P List with internal & external test details
2l.7	Availability of Tags & Inspection Certificates for Batching plants		1	Master T&P List with internal & external test details

**Checklist for Evaluation of HSE Performance**

SL	Parameter for Measurement	M/O	Wt	Supporting Documents
2m.1	Use of Lifting Permit as per requirement		1	Permit Records
2m.2	Use of Height Permit as per requirement		1	Permit Records
2m.3	Use of Hot Work Permit as per requirement		1	Permit Records
2m.4	Use of Excavation permit as per requirement		1	Permit Records
2m.5	Use of Confined space work permit as per requirement		1	Permit Records
2m.6	Use of Grating removal and safety net removal permit as per requirement		1	Permit Records
2m.7	Use of Lockout-Tag out permit as per requirement		1	Permit Records
2m.8	Use of Radiography permit as per requirement		1	Permit Records
2m.9	Use of Night/ Holiday Work Permit as per requirement		1	Permit Records
2m.10	Use of Any other Applicable Permit as per requirement		1	Permit Records
3a	Material safety data sheet(MSDS) available for all chemicals and displayed in usage and storage area?		1	Inspection/ non-conformity records
3b	Spillages of oil/concrete and other chemical is controlled and cleaned by proper method in case of spill?		1	Inspection/ non-conformity records
3c	Availability of adequate number of urinals in workplace and in elevations and maintained	M	1	
3d	Availability of rest rooms for workers at site	M	1	
3e	Availability of Drinking water facility at work spot		1	
3f	Hygienic Labour colony is provided for workers.		1	
4a	Is heavy/complex critical lifting permit obtained for heavy, complex materials before handling/erection activity?		1	Work Permit records
4b	Whether area below lifting activities barricaded		1	Inspection/ non-conformity records
4c	Availability of experienced rigging foreman		1	Experience details of rigging foreman
4d	Is agency is following proper storage and handling procedure as per manufacturer standard for all hazardous material?		1	Procedure for storage & handling
4e	Are oxygen and acetylene cylinders are transported to work place from storage area in trolleys		1	
5a	Whether all deep excavation has been protected by barrier		1	Inspection/ non-conformity records
5b	Sloping/benching & shoring provided for excavation as per requirement?		1	-do-
5c	Proper access and egress provided for excavations?		1	-do-
5d	Blasting is done in controlled manner?		2	-do-
6a	Whether Electrical booth is equipped with Co <sub>2</sub> fire extinguishers and fire buckets filled with sand?		2	Inspection/ non-conformity records
6b	Availability of Illumination lamp in electric booth?		1	-do-
6c	whether Caution Boards have been displayed?		1	-do-
6d	Usage of Metal Plug top for all hand power tools ?		1	-do-
6e	Usage of Insulated welding cables.		1	-do-
6f	Electrical Booth/Distribution Board to be covered by proper Canopy.		1	-do-
6g	Availability of functional & individual 3oma ELCB / RCCB and MCB for protection and conducting periodical check-up?		1	-do-
6h	Double earthing for panel boards and all machinery & proper earth pit with regular inspection available?		1	-do-
6i	Whether Electrician is qualified and experienced		1	Qualification & Experience records of electrician
6j	Availability and usage of Rubber hand gloves by electrician?		1	Inspection/ non-conformity records

**POWER SECTOR- HQ**

FORMAT NO: HSEP:14-F33

REV NO.: 00

PAGE NO. 03 OF 3

**Checklist for Evaluation of HSE Performance**

SL	Parameter for Measurement	M/O	Wt	Supporting Documents
7a	Whether Scaffolding pipes made with steel or aluminum, are being used and checked periodically by experienced/ certified scaffolder?		2	Inspection/ non-conformity records
7b	8mm Stainless Steel wire rope with plastic cladding is provided for life line (Vertical / Horizontal) during height work?		2	-do-
7c	Availability of emergency lighting in case of power failure		1	-do-
7d	Whether all the openings are covered with Safety Nets made of fire proof Nylon?		1	-do-
7e	Whether MS pipe rails around staircases & platforms in usage are provided with top, middle rails and toe guard ?		1	-do-
7f	Whether Ladder with vertical life line /Fall arrestor is available to climb?		1	-do-
7g	Whether all workers deployed for working at height have been issued height pass after undergoing vertigo test?		1	Height Pass records
7h	Whether all workers deployed for height work / climbing ladder are provided and using Double lanyard safety belt?		1	PPE Issue records, inspection/ non-conformity reports
7i	Is all hand tools/Small material used by height workers is tied firmly to prevent fall?		1	-do-
8a	Flash back arrestors for all gas cutting sets is available on Torch side and cylinder side		1	Inspection/ non-conformity records
8b	Oxygen/Acetylene/LPG cylinders not in use have caps in place and stored separately?		1	-do-
8c	Availability of Face screen, Hand gloves, and Apron, for welders		1	-do-
8d	Protection from falling hot molten metal during metal cutting / welding at height by providing GI sheet below the cutting area especially in fire prone areas		1	-do-
9a	Pre-employment medical check-up done for all workers and submitted?		1	Medical check records
9b	Availability of first aid center, with MBBS doctor(Own or Sharing basis)	M	2	Attendance records
9c	Availability of Ambulance facility 24 hours (Own or sharing basis)	M	2	-do-
9d	Is First aid trained personnel's are available and their names are displayed at site?	M	1	-do-
9e	Availability of Emergency vehicle at site		1	
9f	Periodical medical check-up is conducted for all the workers and submitted?		1	Medical check records
9g	Availability of sufficient number of first aid box as per standard list and maintaining record		1	Inspection records
10a	Availability of Fire extinguishers, buckets at all vulnerable points		2	Fire extinguisher records
10b	Periodic fire mock drill conducted?		1	Fire, Mock drill records
10c	Are all flammable materials are stored separately?		1	
10d	Periodic grass cutting is done in material storage area?		1	
10e	Availability of 24V DC lighting in confined space work area		1	
10f	Availability of exhaust fan in confined space work area		1	

**Note:**

- **M: Mandatory; O: Optional.** Points other than mandatory can be excluded with appropriate justification (scope etc.) by BHEL
- Additionally: 30 Marks for each Fatal Accident and 10 mark for each major accident shall be deducted.



# SAFETY WORK CLEARANCE

Permit no. \_\_\_\_\_

Project: \_\_\_\_\_

Emergency Contact Nos: \_\_\_\_\_

Subcontractor: \_\_\_\_\_

## BURNING/WELDING /HOT WORK PERMIT

Area : \_\_\_\_\_ Date: \_\_\_\_\_ Time: \_\_\_\_\_

Name of Site Engineer (Permit Requesting Authority): \_\_\_\_\_ Sign: \_\_\_\_\_

Name of Work Performing Contractor: \_\_\_\_\_

Name of Package In charge: \_\_\_\_\_ Sign: \_\_\_\_\_ Date: \_\_\_\_\_

Description of Work: \_\_\_\_\_

Work Execution Date: \_\_\_\_\_ Time Valid from: \_\_\_\_\_ to \_\_\_\_\_

The above signing person(s) will be responsible to ensure that the above described work will be done under all the safety precautions mentioned on the permit to work.

The following precautions are to be taken:

No.	Item	Yes	Not required
1.	Proper Access/Exit available		
2.	Proper ventilation and /or lighting provided.		
3.	Proper and safe scaffolding, platform, ladder provided.		
4.	Welding machine located in a clean and dry area.		
5.	Welding machine grounded at the equipment and proper leakage current protection device (ELCB) provided for welding machine.		
6.	Emergency STOP buttons are in working condition. Welder /Helper knows how to operate it.		
7.	Welding machine input/output cables, welding holder and weld return clamp (Holder) are insulated and in good condition.		
8.	Welder & Fitter trained to connect ground/work return clamps (Holder) to work place prior to energization of welding machine.		
9.	Gas cylinders are stacked vertically and not below the welding / cutting area. Regulator key is available with cylinder.		
10.	Pressure gauges/Flash back arrestor provided and in working condition.		
11.	Personal Protective equipment Minimum applicable: safety helmet, safety goggles, welding helmet, safety shoes, leather gloves, long sleeve and nose mask -provided		
12.	In case of pits, water removed from the pit and wood/rubber insulation provided.		
13.	Safety signboards are in place.		
14.	Adequate and Suitable nos. of fire fighting extinguisher provided.		
15.	Nearby combustible material removed. Housekeeping done.		
16.	Other		

Name of Contractor Safety Officer: \_\_\_\_\_ Sign: \_\_\_\_\_ Date: \_\_\_\_\_ Time: \_\_\_\_\_

**Reviewed and approved by BHEL Site Engineer (Permit Issuing Authority):**

Name: \_\_\_\_\_ Sign: \_\_\_\_\_ Date: \_\_\_\_\_ Time: \_\_\_\_\_

Name of BHEL Safety Representative: \_\_\_\_\_ Sign: \_\_\_\_\_

I understand the precaution to be taken as described above and as per project requirement and hereby confirm that work will be executed under my supervision by following all precaution and Safety Rules.

Name of Work Performing Authority: \_\_\_\_\_ Sign: \_\_\_\_\_ Date: \_\_\_\_\_ Time: \_\_\_\_\_

**Permit Cancellation:**

I hereby declare that the work is complete, all workers under my control have been withdrawn and the site restored to safe tidy condition.

Name of Work performing Authority: \_\_\_\_\_ Sign: \_\_\_\_\_ Date: \_\_\_\_\_ Time: \_\_\_\_\_

Name of Site Engr. (Permit Requesting Authority): \_\_\_\_\_ Sign: \_\_\_\_\_ Date: \_\_\_\_\_ Time: \_\_\_\_\_

Name of BHEL Site Engr. (Permit Issuing Authority): \_\_\_\_\_ Sign: \_\_\_\_\_ Date: \_\_\_\_\_ Time: \_\_\_\_\_

(This permit is valid only for the date it is issued)

Original at BHEL site

Second Copy – BHEL SAFETY

Third Copy : Contractor



# SAFETY WORK CLEARANCE

Permit no. \_\_\_\_\_

Project: \_\_\_\_\_

Emergency Contact Nos: \_\_\_\_\_

Subcontractor: \_\_\_\_\_

## LIFTING ACTIVITY PERMIT

Area : \_\_\_\_\_ Date: \_\_\_\_\_ Time: \_\_\_\_\_

Name of Site Engineer (Permit Requesting Authority): \_\_\_\_\_ Sign: \_\_\_\_\_ Name of Work

Performing Contractor: \_\_\_\_\_

Name of Package In charge: \_\_\_\_\_ Sign: \_\_\_\_\_ Date: \_\_\_\_\_

Description of Work: \_\_\_\_\_

Work Execution Date: \_\_\_\_\_ Time Valid from: \_\_\_\_\_ to \_\_\_\_\_

*The above signing person(s) will be responsible to ensure that the above described work will be done under all the safety precautions mentioned on the permit to work.*

The following precautions are to be taken:

No.	Item	Yes	Not required
1.	Crane used for lifting activity tested, certified and approved for rated lifting		
2.	All lifting tackles, gears/appliances are tested and certified for lifting works.		
3.	Crane operator is trained and competent for lifting operation.		
4.	Lifting sling/ belt is protected against sharp edge of the jobs to be lifted.		
5.	Access and exit marked and without obstruction.		
6.	Lifting arrangement adequate.		
7.	Unwanted rubbish material removed from work platform.		
8.	Minimum 2 guidelines have been provided for balancing and guiding jobs to be lifted.		
9.	Periphery area of crane booms as well as lifting job is barricaded and unauthorized/no-entry sign board posted.		
10.	Rigger and signal man is trained and competent for lifting work.		
11.	No lifting activity to be carried out during lightening, heavy wind/rain.		
12.	If scaffolding to be used during lift, scaffolding with valid tag available for use.		
13.	Double lanyards safety harness/belt checked and in working condition.		
14.	Safety shoes (non-slip), helmet with chin strap available with employees.		
15.	Others.		

Name of Contractor Safety Officer: \_\_\_\_\_ Sign: \_\_\_\_\_ Date: \_\_\_\_\_ Time: \_\_\_\_\_

**Reviewed and approved by BHEL Site Engineer (Permit Issuing Authority):**

Name: \_\_\_\_\_ Sign: \_\_\_\_\_ Date: \_\_\_\_\_ Time: \_\_\_\_\_

Name of BHEL Safety Representative: \_\_\_\_\_ Sign: \_\_\_\_\_

*I understand the precaution to be taken as described above and as per project requirement and hereby confirm that work will be executed under my supervision by following all precaution and Safety Rules.*

Name of Work Performing Authority: \_\_\_\_\_ Sign: \_\_\_\_\_ Date: \_\_\_\_\_ Time: \_\_\_\_\_

**Permit Cancellation:**

*I hereby declare that the work is complete, all workers under my control have been withdrawn and the site restored to safe tidy condition.*

Name of Work performing Authority: \_\_\_\_\_ Sign: \_\_\_\_\_ Date: \_\_\_\_\_ Time: \_\_\_\_\_

Name of Site Engr. (Permit Requesting Authority): \_\_\_\_\_ Sign: \_\_\_\_\_ Date: \_\_\_\_\_ Time: \_\_\_\_\_

Name of BHEL Site Engr. (Permit Issuing Authority): \_\_\_\_\_ Sign: \_\_\_\_\_ Date: \_\_\_\_\_ Time: \_\_\_\_\_

(This permit is valid only for the date it is issued)

**Original at BHEL site****Second Copy – BHEL SAFETY****Third Copy : Contractor**



# SAFETY WORK CLEARANCE

Permit no. \_\_\_\_\_

Project: \_\_\_\_\_

Emergency Contact Nos: \_\_\_\_\_

Subcontractor: \_\_\_\_\_

## WORKING AT HEIGHT PERMIT

Area : \_\_\_\_\_ Date: \_\_\_\_\_ Time: \_\_\_\_\_

Name of Site Engineer (Permit Requesting Authority): \_\_\_\_\_ Sign: \_\_\_\_\_ Name of Work

Performing Contractor: \_\_\_\_\_

Name of Package In charge: \_\_\_\_\_ Sign: \_\_\_\_\_ Date: \_\_\_\_\_

Description of Work: \_\_\_\_\_

Work Execution Date: \_\_\_\_\_ Time Valid from: \_\_\_\_\_ to \_\_\_\_\_

*The above signing person(s) will be responsible to ensure that the above described work will be done under all the safety precautions mentioned on the permit to work.*

The following precautions are to be taken:

No.	Item	Yes	Not required
1.	All workers on job are medically fit for working at height (Person should not have vertigo)		
2.	Scaffolding with valid tag available for use		
3.	Safety harness with life line support/ fall arrester are checked and in working condition		
4.	Safety shoes ( non-slip), Helmet with chin strip available with employees		
5.	Safety nets are provided as per design and provided 25 ft. below working area & extending 8 ft beyond.		
6.	Horizontal life lines are provided to cater to design specification of 2300kg per person.		
7.	Ladders have been inspected and provided as per BHEL standard/contract.		
8.	All lifting / tightening tools, hand tools/equipment checked and in good condition		
9.	Access and exit marked and without obstruction.		
10.	Lighting arrangement adequate.		
11.	Unwanted and rubbish material removed from working platform.		
12.	Electrical cable, welding Hose/Compressed air hose properly secured and lay down without obstruction.		
13.	Signboards provided on working platforms		
14.	Hazards in the vicinity are identified and communicated to the worker.		
15.	Other		

Name of Contractor Safety Officer: \_\_\_\_\_ Sign: \_\_\_\_\_ Date: \_\_\_\_\_ Time: \_\_\_\_\_

**Reviewed and approved by BHEL Site Engineer (Permit Issuing Authority):**

Name: \_\_\_\_\_ Sign: \_\_\_\_\_ Date: \_\_\_\_\_ Time: \_\_\_\_\_

Name of BHEL Safety Representative: \_\_\_\_\_ Sign: \_\_\_\_\_

*I understand the precaution to be taken as described above and as per project requirement and hereby confirm that work will be executed under my supervision by following all precaution and Safety Rules.*

**Name of Work Performing Authority:** \_\_\_\_\_ **Sign:** \_\_\_\_\_ **Date:** \_\_\_\_\_ **Time:** \_\_\_\_\_**Permit Cancellation:**

*I hereby declare that the work is complete, all workers under my control have been withdrawn and the site restored to safe tidy condition.*

Name of Work performing Authority: \_\_\_\_\_ Sign: \_\_\_\_\_ Date: \_\_\_\_\_ Time: \_\_\_\_\_

Name of Site Engr. (Permit Requesting Authority): \_\_\_\_\_ Sign: \_\_\_\_\_ Date: \_\_\_\_\_ Time: \_\_\_\_\_

Name of BHEL Site Engr. (Permit Issuing Authority): \_\_\_\_\_ Sign: \_\_\_\_\_ Date: \_\_\_\_\_ Time: \_\_\_\_\_

(This permit is valid only for the date it is issued)

**Original at BHEL site****Second Copy – BHEL SAFETY****Third Copy : Contractor**





PSSR

## MONTHLY PLAN &amp; REVIEW WITH CONTRACTOR

Page 1 of 6

Name of Project		Contract No.	
Name of Work		Name of Contractor	

**PART- A: PLAN/ REVIEW OF WORK FOR THE MONTH OF .....**

Date of Plan/ Review.....

SN.	Description of Work	Unit of Measurement	Unit Rate	Planned		Cumulative Shortfall attributable to contractor upto last month (Refer Note 1)		Achieved		Shortfall attributable to BHEL w.r.t Plan (as per Col. 3 of Part-D)		Cumulative Shortfall attributable to Contractor upto & including this month		REMARKS (Reasons for Shortfall attributable to Contractor. Supporting documents to be kept as record.)
				(QTY Planned for the month as per Part -C of last month)										
(a)	(b)	(c)	(d)	A		B		C		D		E=A+B-C-D		
				Phy.	Financial	Phy.	Financial	Phy.	Financial	Phy.	Financial	Phy.	Financial	
	Value of Other Items not mentioned above but planned to be executed in this month													
Total					ΣA		ΣB		ΣC		ΣD		ΣE	

BHEL  
(Sign with name, designation and date)

CONTRACTOR  
(Sign with name, designation and date)



PSSR

## MONTHLY PLAN &amp; REVIEW WITH CONTRACTOR

Page 2 of 6

Name of Project		Contract No.	
Name of Work		Name of Contractor	

**PART- A: Contd.....**

Note 1: In addition to the work planned as per Col. 'A', Contractor shall also make full efforts to minimize the 'Cumulative shortfall attributable to contractor upto the month' as mentioned in Col. 'B' by enhancing its resources, so as to achieve the completion of activities as per agreed schedule. In case contractor is not able to execute the entire shortfall, then BHEL 'Engineer in-charge', shall decide the priority of work to be executed and it shall be binding on the contractor.

Note 2: Percentage Shortfall attributable to contractor w.r.t. "Plan - Shortfall attributable to BHEL" for the month =  $[(\Sigma E - \Sigma B) / (\Sigma A - \Sigma D)] \times 100$   
In case,  $(\Sigma E - \Sigma B)$  is negative, then it shall be treated as zero percent."

Note 3: Form 14 should include all items being planned in the current month, and all items against which shortfall was attributable to contractor till previous month. However, for practical reason, if it is not possible to mention some of the items in Form-14 being planned to be executed in this month, then also value of such items shall necessarily be included in calculation of Total Value.

Note 4: In case reason for shortfall attributable to contractor is w.r.t. T&P and Manpower, it should be in conformity with Part B1 and B2.

BHEL  
(Sign with name, designation and date)

CONTRACTOR  
(Sign with name, designation and date)



PSSR

## MONTHLY PLAN &amp; REVIEW WITH CONTRACTOR

Page 3 of 6

Name of Project		Contract No.	
Name of Work		Name of Contractor	

**PART – B-1: PLAN/REVIEW OF DEPLOYMENT OF MAJOR T&Ps FOR THE MONTH OF .....**

Date of Plan/ Review.....

**CONTRACTOR'S SCOPE: -**

SN.	PLAN				DEPLOYMENT STATUS			REMARKS (Works affected due to non-deployment of T&Ps)
	Major T&P to be deployed as per work planned for the month	QTY	Deployment Period (in days)	Weightage assigned to planned T&P (in fraction such that $\Sigma C = 1$ )	Actual Deployed Quantity	Actual Deployment Period (in days)	Weighted T&P Deployed	
		A	B	C	D	E	$F = (C \times D \times E) / (A \times B)$	

Note: In case,  $E > B$ , it shall be considered as  $E = B$ . Similarly, in case  $D > A$ , it shall be considered as  $D = A$ .Percentage of T&P Deployed =  $\Sigma F \times 100$ **BHEL SCOPE: -**

SN.	PLAN			DEPLOYMENT STATUS			REMARKS (Works affected due to non-deployment of T&Ps)
	Major T&P to be deployed as per work planned for the month	QTY	Deployment Period (in days)	Actual Deployed Quantity	Actual Deployment Period (in days)		

BHEL  
(Sign with name, designation and date)

CONTRACTOR  
(Sign with name, designation and date)



PSSR

## MONTHLY PLAN &amp; REVIEW WITH CONTRACTOR

Page 4 of 6

Name of Project		Contract No.	
Name of Work		Name of Contractor	

PART – B-2: PLAN/ REVIEW OF DEPLOYMENT OF MANPOWER FOR THE MONTH OF .....

Date of Plan/ Review.....

## CONTRACTOR'S SCOPE: -

SN.	Area of Work	Category of Labour	No. of Labour required as per category	Deployment Period (in days)	No. of Labour actually deployed	Actual Deployment Period (in days)	REMARKS (Works affected due to non-availability of labour)
			A	B	C	D	

$$\text{Percentage of Manpower Deployed} = 100 \times \frac{\sum(C \times D)}{\sum(A \times B)}$$

BHEL  
(Sign with name, designation and date)

CONTRACTOR  
(Sign with name, designation and date)



PSSR

## MONTHLY PLAN &amp; REVIEW WITH CONTRACTOR

Page 5 of 6

Name of Project		Contract No.	
Name of Work		Name of Contractor	

**PART – C: PLAN(PHYSICAL) FOR THE NEXT MONTH i.e. ....**

Date of Plan .....

SN.	Description of work	Original Planned Quantity	Planned Quantity (excluding shortfalls attributable to contractor till date)	Unit of Measurement	T&Ps Required				Manpower Required		REMARKS (Reasons for difference in Original Planned Quantity w.r.t. Planned quantity to be given)
					Contractor Scope		BHEL Scope		Category of Labour	No. of Labour required as per Category	
					Major T&P to be deployed as per work planned for the month	Quantity	Major T&P to be deployed as per work planned for the month	Quantity			

Note 1: Planned quantity should be based on available/ expected fronts/ inputs in the next month

Note 2: "Original Planned Quantity" shall be as per latest jointly agreed programme between BHEL and Contractor before commencement of work or at the time of latest Time Extension, as the case may be.

BHEL  
(Sign with name, designation and date)

CONTRACTOR  
(Sign with name, designation and date)



PSSR

## MONTHLY PLAN &amp; REVIEW WITH CONTRACTOR

Page 6 of 6

Name of Project		Contract No.	
Name of Work		Name of Contractor	

**PART – D: REASONS FOR SHORTFALL ATTRIBUTABLE TO BHEL IN RESPECT OF PLAN FOR THE MONTH.....**

SN.	Description of Work (from Part-A)	Quantities Affected		Reasons for Shortfall attributable to BHEL	Agency responsible for reasons for Shortfall	Remarks (Supporting Documents in respect of agency responsible)
		(Physical Quantity)	Unit of Measu- rement			
1	2	3	4	5	6	7

Note1: Reasons for shortfall shall include non-availability of fronts/ drawings/ materials/ T&P (BHEL Scope)/ clearances etc. and other hindrances for which contractor is not responsible.

Note2: Agency responsible may be BHEL Site/ MUs/ Design Centre/ BHEL Customer/ other Contractors etc.

BHEL

(Sign with name, designation and date)

PROFORMA OF BANK GUARANTEE (in lieu of SECURITY DEPOSIT)  
(On non-Judicial paper of appropriate value)  
(Para 4.7.6 of Works Accounts Manual)

Bank Guarantee No.....  
Date.....

To  
(Employer’s Name and Address)  
.....

In consideration of Bharat Heavy Electricals Limited (hereinafter referred to as the 'Employer' which expression shall unless repugnant to the context or meaning thereof, include its successors and permitted assigns) incorporated under the Companies Act, 1956 and having its registered office at *BHEL House, Siri Fort, Asiad, New Delhi – 110049* through its unit at *Bharat Heavy Electricals Limited, Power Sector Southern Region, Tek Towers, No.11, Old Mahabalipuram Road, Okkiyam Thoraipakkam, Chennai - 600097* having agreed to exempt \_\_\_\_\_<sup>1</sup> (Name of the Vendor / Contractor / Supplier) with its registered office at \_\_\_\_\_<sup>2</sup> (hereinafter called the said “Contractor” which term includes supplier), from demand under the terms and conditions of the Contract arising vide Letter of Intent (LOI) reference No. \_\_\_\_\_ dated \_\_\_\_\_<sup>3</sup> valued at Rs. \_\_\_\_\_<sup>4</sup> (Rupees \_\_\_\_\_ only)<sup>4</sup> (hereinafter called the said Contract), of Security Deposit for the due fulfilment by the said Contractor of the terms and conditions contained in the said Contract, on production of a Bank Guarantee for Rs. \_\_\_\_\_<sup>5</sup> (Rupees \_\_\_\_\_ only),

We, the .....(Name & address of the Bank)  
..... having our Head Office at  
.....(hereinafter referred to as the Bank), at the request of  
\_\_\_\_\_ [Contractor(s)], being the Guarantor under this Guarantee, do hereby irrevocably and unconditionally undertake to forthwith and immediately pay to the Employer, an amount not exceeding Rs. \_\_\_\_\_ without any demur, immediately on demand from the Employer and without any reservation, protest, and recourse and without the Employer needing to prove or demonstrate reasons for its such demand

Any such demand made on the bank, shall be conclusive as regards the amount due and payable by the Bank under this guarantee. However, our liability under this guarantee shall be restricted to an amount not exceeding Rs. \_\_\_\_\_<sup>5</sup>.

We undertake to pay to the Employer any money so demanded notwithstanding any dispute or disputes raised by the Contractor(s) in any suit or proceeding pending before any Court or Tribunal or Arbitrator or any other authority, our liability under this present being absolute and unequivocal.

The payment so made by us under this guarantee shall be a valid discharge of our liability for payment hereunder and the Contractor(s) shall have no claim against us for making such payment.

We, further agree that the guarantee herein contained shall remain in full force and effect during the period that would be taken for the performance of the said Contract and that it shall continue to be enforceable till all the dues of the Employer under or by virtue of the said Contract have been fully paid and its claims satisfied & the Employer certifies that the terms and conditions of the said Contract have been fully and properly carried out by the said contractor(s) or acceptance of the final bill or discharge of this guarantee by the Employer, whichever is earlier. This guarantee shall initially remain in force upto and including \_\_\_\_\_<sup>6</sup> and shall be extended from time to time for such period as may

be desired by the Employer. Unless a demand or claim under this guarantee is made on us in writing on or before the \_\_\_\_\_<sup>7</sup>, we shall be discharged from all the liability under this guarantee thereafter.

We, \_\_\_\_\_(indicate the name of the Bank) further agree with the Employer that the Employer shall have the fullest liberty without our consent and without affecting in any manner our obligations hereunder to vary any of the terms and conditions of the said Contract or to extend time of performance by the said contractor(s) from time to time or to postpone for any time or from time to time any of the powers exercisable by the Employer against the said contractor(s) and to forbear or enforce any of the terms and conditions relating to the said Contract and we shall not be relieved from our liability by any reason of any such variation or extension being granted to the said contractor(s) or for any forbearance, act or omission on the part of the Employer or any indulgence by the Employer to the said contractor(s) or by any such matter or thing whatsoever which under the law relating to sureties would but for this provision have effect of so relieving us.

The Bank also agrees that the Employer at its option shall be entitled to enforce this Guarantee against the Bank as a principal debtor, in the first instance without proceeding against the Contractor and notwithstanding any security or other guarantee that the Employer may have in relation to the Contractor's liabilities.

This Guarantee shall not be determined or affected by liquidation or winding up, dissolution or change of constitution or insolvency of the Contractor but shall in all respects and for all purposes be binding and operative until payment of all money payable to the Employer in terms thereof. This guarantee will not be discharged due to the change in the constitution of the Bank or the Contractor(s).

We, ..... BANK lastly undertake not to revoke this guarantee during its currency except with the previous consent of the Employer in writing.  
Notwithstanding anything to the contrary contained hereinabove:

- a) The liability of the Bank under this Guarantee shall not exceed.....<sup>5</sup>
- b) This Guarantee shall be valid up to .....<sup>6</sup>
- c) Unless the Bank is served a written claim or demand on or before \_\_\_\_\_<sup>7</sup> all rights under this guarantee shall be forfeited and the Bank shall be relieved and discharged from all liabilities under this guarantee irrespective of whether or not the original bank guarantee is returned to the Bank.

We, \_\_\_\_\_ Bank, have power to issue this Guarantee under law and the undersigned as a duly authorized person has full powers to sign this Guarantee on behalf of the Bank.

Date \_\_\_\_\_ Day of \_\_\_\_\_  
for \_\_\_\_\_ (indicate the name of the Bank)

(Signature of Authorised signatory)

<sup>1</sup> NAME OF VENDOR /CONTRACTOR / SUPPLIER  
<sup>2</sup> REGISTERED OFFICE ADDRESS OF THE VENDOR /CONTRACTOR / SUPPLIER.  
<sup>3</sup> LETTER OF INTENT(LOI) REFERENCE NO. WITH DATE  
<sup>4</sup> CONTRACT VALUE (AS MENTIONED IN LOI)  
<sup>5</sup> BG AMOUNT IN FIGURES AND WORDS  
<sup>6</sup> VALIDITY DATE  
<sup>7</sup> DATE OF EXPIRY OF CLAIM PERIOD (CLAIM PERIOD SHALL BE MINIMUM OF 3 MONTHS AFTER VALIDITY DATE)

Note:

1. The BG should be on Non-Judicial Stamp paper/e-stamp paper of appropriate value as per Stamp Act prevailing in the State(s) where the BG is submitted or is to be acted upon or the rate prevailing in the State where the BG was executed, whichever is higher. The Stamp Paper/e-stamp paper shall be purchased in the name of Vendor/Contractor/Supplier /Bank issuing the guarantee.
2. In Case of Bank Guarantees submitted by Foreign Vendors-
  - a. From Nationalized/Public Sector / Private Sector/ Foreign Banks (BG issued by Branches in India) can be accepted subject to the condition that the Bank Guarantee should be enforceable in the town/city or at nearest branch where the Unit is located i.e. Demand can be presented at the Branch located in the town/city or at nearest branch where the Unit is located.
  - b. From Foreign Banks (wherein Foreign Vendors intend to provide BG from local branch of the Vendor Country's Bank)
    - b.1 In such cases, in the Tender Enquiry/ Contract itself, it may be clearly specified that Bank Guarantee issued by any of the Consortium Banks only will be accepted by BHEL. As such, Foreign Vendor needs to make necessary arrangements for issuance of Counter- Guarantee by Foreign Bank in favour of the Indian Bank's (BHEL's Consortium Bank) branch in India. It is advisable that all charges for issuance of Bank Guarantee/ counter- Guarantee should be borne by the Foreign Vendor. The tender stipulation should clearly specify these requirements.
    - b.2 In case, Foreign Vendors intend to provide BG from Overseas Branch of our Consortium Bank (e.g. if a BG is to be issued by SBI Frankfurt), the same is acceptable. However, the procedure at sl.no. b.1 will required to be followed.
    - b.3 The BG issued may preferably be subject to Uniform Rules for Demand Guarantees (URDG) 758 (as amended from time to time).

**PROCEDURE FOR CONDUCT OF CONCILIATION PROCEEDINGS**

1. The proceedings of Conciliation shall broadly be governed by Part-III of the Arbitration and Conciliation Act 1996 or any statutory modification thereof and as provided herein:
2. The party desirous of resorting to Conciliation shall send an invitation/notice in writing to the other party to conciliate specifying all points of Disputes with details of the amount claimed. The party concerned shall not raise any new issue thereafter. Parties shall also not claim any interest on claims/counter-claims from the date of notice invoking Conciliation till the conclusion of the Conciliation proceedings. If BHEL is to initiate Conciliation, then, the invitation to Conciliate shall be extended to the concerned Stakeholder in **Format 7** hereto. Where the stakeholder is to initiate the Conciliation, the notice for initiation of Conciliation shall be sent in **Format-8** hereto.
3. The party receiving the invitation/notice for Conciliation shall within 30 days of receipt of the notice of Conciliation intimate its consent for Conciliation along with its counter-claims, if any.
4. The Conciliation in a matter involving claim or counter-claim (whichever is higher) up to Rs 5 crores shall be carried out by sole Conciliator nominated by BHEL while in a matter involving claim or counter-claim (whichever is higher) of more than Rs 5 crores Conciliation shall be carried out by 3 Conciliators nominated by BHEL. The appointment of Conciliator(s) shall be completed and communicated by the concerned Department/Group of BHEL Unit/Division/Region/Business Group to the other party and the Conciliator(s) within 30 days from the date of acceptance of the invitation to conciliate by the concerned party in the **Format-9**. The details of the Claim, and counter-claim, if any, shall be intimated to the Conciliator(s) simultaneously in **Format-5**.
5. The Parties shall be represented by only their duly authorized in-house executives/officers and neither Party shall be represented by a Lawyer.
6. The first meeting of the IEC shall be convened by the IEC by sending appropriate communication/notice to both the parties as soon as possible but not later than 30 days from the date of his/their appointment. The hearings in the Conciliation proceeding shall ordinarily be concluded within two (2) months and, in exceptional cases where parties have expressed willingness to settle the matter or there exists possibility of settlement in the matter, the proceedings may be extended by the IEC by a maximum of further 2 months with the consent of the Parties subject to cogent reasons being recorded in writing.

- 7.** The IEC shall thereafter formulate recommendations for settlement of the Disputes supported by reasons at the earliest but in any case within 15 days from the date of conclusion of the last hearing. The recommendations so formulated along with the reasons shall be furnished by the IEC to both the Parties at the earliest but in any case within 1 month from the date of conclusion of the last hearing.
- 8.** Response/modifications/suggestions of the Parties on the recommendations of the IEC are to be submitted to the IEC within time limit stipulated by the IEC but not more than 15 days from the date of receipt of the recommendations from the IEC.
- 9.** In the event, upon consideration, further review of the recommendations is considered necessary, whether by BHEL or by the other Party, then, the matter can be remitted back to the IEC with request to reconsider the same in light of the issues projected by either/both the Parties and to submit its recommendations thereon within the following 15 days from the date of remitting of the case by either of the Parties.
- 10.** Upon the recommendations by the Parties, with or without modifications, as considered necessary, the IEC shall be called upon to draw up the Draft Settlement Agreement in terms of the recommendations.
- 11.** When a consensus can be arrived at between the parties only in regard to any one or some of the issues referred for Conciliation the draft Settlement Agreement shall be accordingly formulated in regard to the said Issue(s), and the said Settlement Agreement, if signed, by the parties, shall be valid only for the said issues. As regards the balance issues not settled, the parties may seek to resolve them further as per terms and conditions provided in the contract.
- 12.** In case no settlement can be reached between the parties, the IEC shall by a written declaration, pronounce that the Conciliation between the parties has failed and is accordingly terminated.
- 13.** Unless the Conciliation proceedings are terminated in terms of para 22 (b), (c) & (d) herein below, the IEC shall forward his/its recommendations as to possible terms of settlement within one (1) month from the date of last hearing. The date of first hearing of Conciliation shall be the starting date for calculating the period of 2 months.
- 14.** In case of 3 members IEC, 2 members of IEC present will constitute a valid quorum for IEC and meeting can take place to proceed in the matter after

seeking consent from the member who is not available. If necessary, videoconferencing may be arranged for facilitating participation of the members. However, the IEC recommendations will be signed by all members. Where there is more than one (1) Conciliator, as a general rule they shall act jointly. In the event of differences between the Members of IEC, the decision/recommendations of the majority of the Members of IEC shall prevail and be construed as the recommendation of the IEC.

- 15.** The Draft Settlement Agreement prepared by the IEC in terms of the consensus arrived at during the Conciliation proceedings between the Parties shall be given by the IEC to both the parties for putting up for approval of their respective Competent Authority.
- 16.** Before submitting the draft settlement agreement to BHEL's Competent Authority viz. the Board Level Committee on Alternative Dispute Resolution (BLCADR) for approval, concurrence of the other party's Competent Authority to the draft settlement agreement shall be obtained by the other party and informed to BHEL within 15 days of receipt of the final draft settlement agreement by it. Upon approval by the Competent Authority, the Settlement Agreement would thereafter be signed by the authorized representatives of both the Parties and authenticated by the members of the IEC.
- 17.** In case the Draft Settlement Agreement is rejected by the Competent Authority of BHEL or the other Party, the Conciliation proceedings would stand terminated.
- 18.** A Settlement Agreement shall contain a statement to the effect that each of the person(s) signing thereto (i) is fully authorized by the respective Party(ies) he/she represents, (ii) has fully understood the contents of the same and (iii) is signing on the same out of complete freewill and consent, without any pressure, undue influence.
- 19.** The Settlement Agreement shall thereafter have the same legal status and effect as an arbitration award on agreed terms on the substance of the dispute rendered by an arbitral tribunal passed under section 30 of the Arbitration and Conciliation Act, 1996.
- 20.** Acceptance of the Draft Settlement Agreement/recommendations of the Conciliator and/or signing of the Settlement Agreement by BHEL shall however, be subject to withdrawal/closure of any arbitral and/or judicial proceedings initiated by the concerned Party in regard to such settled issues.
- 21.** Unless otherwise provided for in the agreement, contract or the Memorandum of Understanding, as the case may be, in the event of likelihood of prolonged

absence of the Conciliator or any member of IEC, for any reason/incapacity, the Competent Authority/Head of Unit/Division/Region/Business Group of BHEL may substitute the Conciliator or such member at any stage of the proceedings. Upon appointment of the substitute Conciliator(s), such reconstituted IEC may, with the consent of the Parties, proceed with further Conciliation into the matter either de-novo or from the stage already reached by the previous IEC before the substitution.

**22.** The proceedings of Conciliation under this Scheme may be terminated as follows:

- a. On the date of signing of the Settlement agreement by the Parties; or,
- b. By a written declaration of the IEC, after consultation with the parties, to the effect that further efforts at conciliation are no longer justified, on the date of the declaration; or,
- c. By a written declaration of the Parties addressed to the IEC to the effect that the Conciliation proceedings are terminated, on the date of the declaration; or,
- d. By a written declaration of a Party to the other Party and the IEC, if appointed, to the effect that the Conciliation proceedings are terminated, on the date of the declaration; or,
- e. On rejection of the Draft Settlement Agreement by the Competent Authority of BHEL or the other Party.

**23.** The Conciliator(s) shall be entitled to following fees and facilities:

<b>Sl No</b>	<b>Particulars</b>	<b>Amount</b>
1	Sitting fees	Each Member shall be paid a Lump Sum fee of Rs 75,000/- for the whole case payable in terms of paragraph No. 27 herein below.
2	Towards drafting of settlement agreement	In cases involving claim and/or counter-claim of up to Rs 5crores. Rs 50,000/- (Sole Conciliator) In cases involving claim and/or counter-claim of exceeding Rs 5 crores but less than Rs 10 crores. Rs 75,000 (per Conciliator)

Sl No	Particulars	Amount
		<p>In cases involving claim and/or counter-claim of more than Rs 10 crores.</p> <p>Rs 1,00,000/- (per Conciliator)</p> <p>Note: The aforesaid fees for the drafting of the Settlement Agreement shall be paid on the,</p> <p>Signing of the Settlement Agreement after approval of the Competent Authority</p> <p>or</p> <p>Rejection of the proposed Settlement Agreement by the Competent Authority of BHEL.</p>
<b>3</b>	Secretarial expenses	<p>Rs 10,000/- (one time) for the whole case for Conciliation by a Sole Member IEC.</p> <p>Where Conciliation is by multi member Conciliators –Rs 30,000/- (one time)- to be paid to the IEC</p>
<b>4</b>	<p>Travel and transportation and stay at outstation Retired Senior Officials of other Public Sector Undertakings (pay scale wise equivalent to or more than E-8 level of BHEL)</p> <p>Others</p>	<p>As per entitlement of the equivalent officer (pay scale wise) in BHEL.</p> <p>As per the extant entitlement of whole time Functional Directors in BHEL.</p> <p>Ordinarily, the IEC Member(s) would be entitled to travel by air Economy Class.</p>
<b>5</b>	Venue for meeting	<p>Unless otherwise agreed in the agreement, contract or the Memorandum of Understanding, as the case may be, the venue/seat of proceedings shall be the location of the concerned Unit / Division / Region /</p>

Sl No	Particulars	Amount
		Business Group of BHEL. Without prejudice to the seat/venue of the Conciliation being at the location of concerned BHEL Unit / Division / Region / Business Group, the IEC after consulting the Parties may decide to hold the proceedings at any other place/venue to facilitate the proceedings. Unless, Parties agree to conduct Conciliation at BHEL premises, the venue is to be arranged by either Party alternately.

- 24.** The parties will bear their own costs including cost of presenting their cases/evidence/witness(es)/expert(s) on their behalf. The parties agree to rely upon documentary evidence in support of their claims and not to bring any oral evidence in IEC proceedings.
- 25.** If any witness(es) or expert(s) is/are, with the consent of the parties, called upon to appear at the instance of the IEC in connection with the matter, then, the costs towards such witness(es)/expert(s) shall be determined by the IEC with the consent of the Parties and the cost so determined shall be borne equally by the Parties.
- 26.** The other expenditures/costs in connection with the Conciliation proceedings as well as the IEC's fees and expenses shall be shared by the Parties equally.
- 27.** Out of the lump sum fees of Rs 75,000/- for Sitting Fees, 50% shall be payable after the first meeting of the IEC and the remaining 50% of the Sitting Fees shall be payable only after termination of the conciliation proceedings in terms of para 22 hereinabove.
- 28.** The travelling, transportation and stay at outstation shall be arranged by concerned Unit as per entitlements as per Serial No. 4 of the Table at para 23 above, and in case such arrangements are not made by the BHEL Unit, the same shall be reimbursed to the IEC on actuals limited to their entitlement as per Serial No. 4 of the Table at Para 23 above against supporting documents. The IEC Member(s) shall submit necessary invoice for claiming the fees/reimbursements.
- 29.** The Parties shall keep confidential all matters relating to the conciliation proceedings. Confidentiality shall extend also to the settlement agreement,

except where its disclosure is necessary for purposes of its implementation and enforcement or as required by or under a law or as per directions of a Court/Governmental authority/ regulatory body, as the case may be.

- 30.** The Parties shall not rely upon or introduce as evidence in any further arbitral or judicial proceedings, whether or not such proceedings relate to the Disputes that is the subject of the Conciliation proceedings:
  - a.** Views expressed or suggestions made by the other party in respect of a possible settlement of the Disputes;
  - b.** admissions made by the other party in the course of the Conciliator proceedings;
  - c.** proposals made by the Conciliator;
  - d.** The fact that the other Party had indicated his willingness to accept a proposal for settlement made by the Conciliator.
- 31.** The Parties shall not present the Conciliator(s) as witness in any Alternative Dispute Resolution or Judicial proceedings in respect of a Disputes that is/was the subject of that particular Conciliation proceeding.
- 32.** None of the Conciliators shall act as an arbitrator or as a representative or counsel of a Party in any arbitral or judicial proceeding in respect of a Disputes that is/was the subject of that particular Conciliation proceeding.
- 33.** The Parties shall not initiate, during the Conciliation proceedings, any arbitral or judicial proceedings in respect of a Disputes that is the subject matter of the Conciliation proceedings except that a Party may initiate arbitral or judicial proceedings where, in his opinion, such proceedings are necessary for preserving his rights including for preventing expiry of period of limitation. Unless terminated as per the provisions of this Scheme, the Conciliation proceedings shall continue notwithstanding the commencement of the arbitral or judicial proceedings and the arbitral or judicial proceedings shall be primarily for the purpose of preserving rights including preventing expiry of period of limitation.
- 34.** The official language of Conciliation proceedings under this Scheme shall be English unless the Parties agree to some other language.

**STATEMENT OF CLAIMS/COUNTER CLAIMS TO BE SUBMITTED TO THE  
IEC BY BOTH THE PARTIES**

1. Chronology of the Disputes
2. Brief of the Contract/MoU/Agreement/LOI/LOA
3. Brief history of the Disputes:
4. Issues:
5. Details of Clam(s)/Counter Claim(s):

<b>SI. No.</b>	<b>Description of claim(s)/Counter Claim</b>	<b>Amount (in INR)Or currency applicable in the contract</b>	<b>Relevant contract clause</b>

6. Basis/Ground of claim(s)/counter claim(s) (along with relevant clause of contract)

**Note**– *The Statement of Claims/ Counter Claims may ideally be restricted to maximum limit of 20 pages. Relevant documents may be compiled and submitted along with the statement of Claims/ Counter Claims. The statement of Claims/ Counter Claims is to be submitted to all IEC members and to the other party by post as well as by email.*

**FORMAT FOR NOTICE INVOKING CONCILIATION CLAUSE BY BHEL FOR REFERRING THE DISPUTES TO CONCILIATION THROUGH IEC**

To,

M/s. (Stakeholder's name)

Subject: **NOTICE FOR INVOCATION OF THE CONCILIATION CLAUSE OF THE CONTRACT BY BHEL**

Ref: Contract No/MoU/Agreement/LOI/LOA& date \_\_\_\_\_.

Dear Sir/Madam,

As you are aware, with reference to above referred Contract/MoU/Agreement/LOI/LOA, certain disputes have arisen, which, in spite of several rounds of mutual discussions and various correspondences have remained unresolved. The brief particulars of our claims which arise out of the above- referred Contract/MoU/Agreement/LOI/LOA are reproduced hereunder:

Sl. No.	Claim description	Amount involved

As you are aware, there is a provision in the captioned Contract/MoU/Agreement/LOI/ LOA for referring disputes to conciliation.

In terms of Clause -----of Procedure i.e., Annexure ----- to the Contract/MoU /Agreement / LOI / LOA, we hereby seek your consent to refer the matter to Conciliation by Independent Experts Committee to be appointed by BHEL. You are invited to provide your consent in writing to proceed with conciliation into the above mentioned disputes within a period of 30 days from the date of this letter along with details of counter-claims, if any, which you might have with regard to the subject Contract/ MoU/ Agreement/ LOI/ LOA.

Please note that upon receipt of your consent in writing within 30 days of the date of receipt of this letter by you, BHEL shall appoint suitable person(s) from the BHEL Panel of Conciliators.

This letter is being issued without prejudice to our rights and contentions available under the contract and law.

Thanking you  
Yours faithfully

**Representative of BHEL**

**Note:** The Format may be suitably modified, as required, based on facts and circumstances of the case.

**FORMAT FOR NOTICE INVOKING CONCILIATION CLAUSE BY A  
STAKEHOLDER FOR REFERRING THE DISPUTES TO CONCILIATION  
THROUGH IEC**

To,

BHEL (Head of the Unit/Division/Region/Business Group)

Subject: **NOTICE FOR INVOCATION OF THE CONCILIATION CLAUSE OF THE  
CONTRACT BY A STAKEHOLDER**

Ref: Contract No/MoU/Agreement/LOI/LOA& date \_\_\_\_\_.

Dear Sir/Madam,

As you are aware, with reference to above referred Contract/MoU/Agreement/LOI/LOA, certain disputes have arisen, which, in spite of several rounds of mutual discussions and various correspondences have remained unresolved. The brief particulars of our claims which have arisen out of the above-referred Contract/MoU/Agreement/LOI/LOA are enumerated hereunder:

Sl. No.	Claim description	Amount involved

As you are aware, there is a provision in the captioned Contract/MoU/Agreement/LOI/ LOA for referring inter-se disputes of the Parties to conciliation.

We wish to refer the above-said disputes to Conciliation as per the said Clause of the captioned Contract/MoU/Agreement/LOI/ LOA. In terms of Clause -----of Procedure i.e., Annexure ----- to the Contract/MoU /Agreement / LOI / LOA, we hereby invite BHEL to provide its consent in writing to proceed with conciliation into the above mentioned disputes within a period of 30 days from the date of this letter along with details of counter-claims, if any, which it might have with regard to the subject Contract/ MoU/ Agreement/ LOI/ LOA and to appoint suitable person(s) as Conciliator(s) from the BHEL Panel of Conciliators.

This letter is being issued without prejudice to our rights and contentions available under the contract and law.

Thanking you  
Yours faithfully

**Representative of the Stakeholder**

**Note:** The Format may be suitably modified, as required, based on facts and circumstances of the case.

**FORMAT FOR INTIMATION TO THE STAKEHOLDER ABOUT APPOINTMENT OF CONCILIATOR/IEC**

To,

M/s. (Stakeholder's name)

Subject: **INTIMATION BY BHEL TO THE STAKEHOLDER AND CONCILIATOR(S) ABOUT APPOINTMENT OF CONCILIATOR/IEC**

Ref: Contract No/MoU/Agreement/LOI/LOA& date \_\_\_\_\_.

Sir,

This is with reference to letter dated ----- regarding reference of the disputes arising in connection with the subject Contract No /MoU/Agreement/LOI/LOA to conciliation and appointment of Conciliator(s).

In pursuance of the said letter, the said disputes are assigned to conciliation and the following persons are nominated as Conciliator(s) for conciliating and assisting the Parties to amicably resolve the disputes in terms of the Arbitration & Conciliation Act, 1996 and the Procedure ---- to the subject Contract ...../MoU/Agreement/LOI/LOA, if possible.

Name and contact details of Conciliator(s)

a) .....

b) .....

c) .....

You are requested to submit the Statement of Claims or Counter-Claims (strike off whichever is inapplicable) before the Conciliator(s) in Format 5 (enclosed herewith) as per the time limit as prescribed by the Conciliator(s).

Yours faithfully,

**Representative of BHEL**

CC: To Conciliator(s)... for Kind Information please.

Encl: As above

**Note:** The Format may be suitably modified, as required, based on facts and circumstances of the case.