

SCHEDULE 1

Steel/Cast Roll - SRM 300/R15

Steel Roll-SRM 300/R15

DRAWING NO.: 20-ST-115-02-160/11

SL.NO.: 4

RADIUS, R: 15

TDC NO.: TDC/TE/MFG-06 REV.NO.: 04/ DATE: 26.08.2010

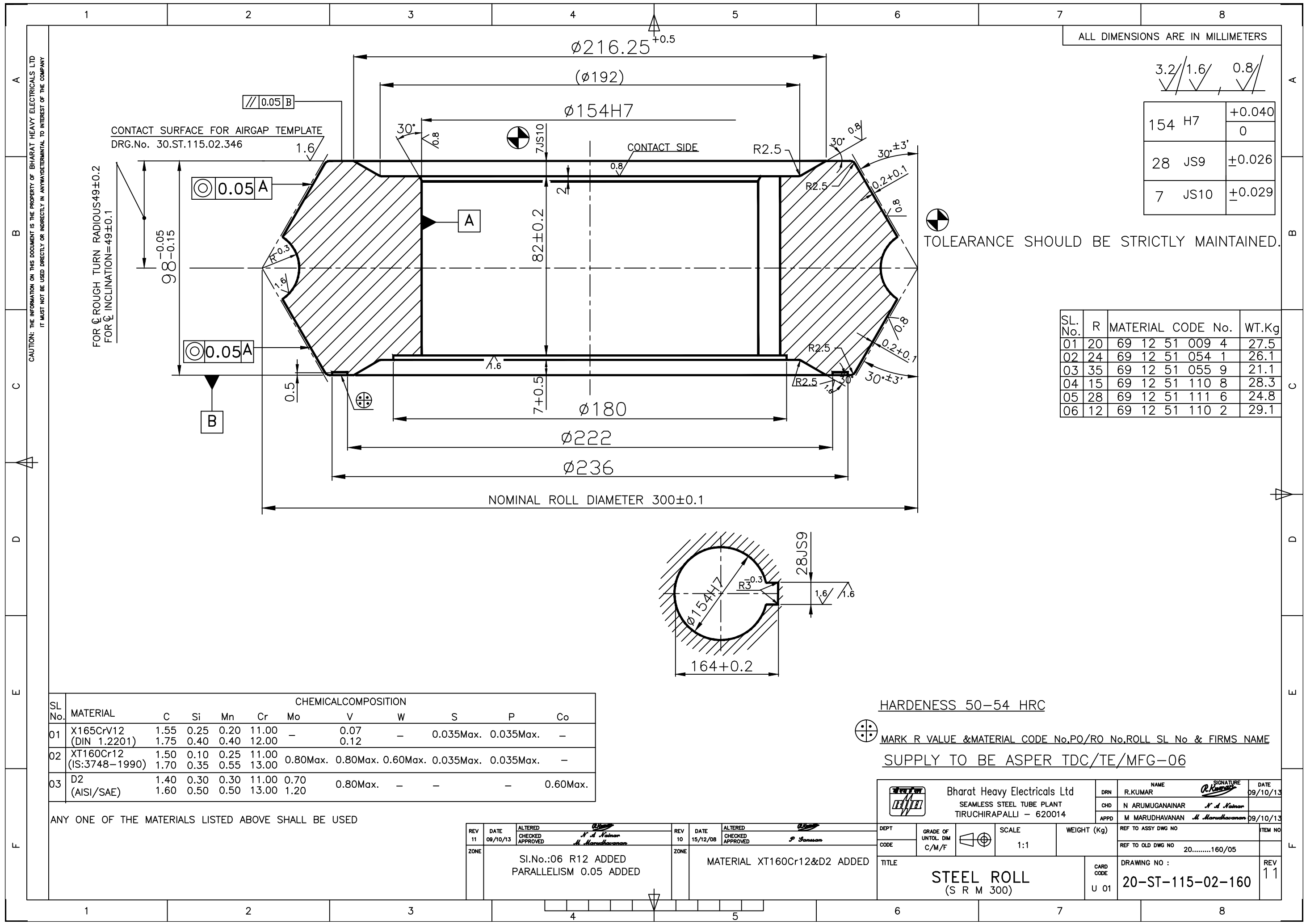

ALL DIMENSIONS ARE IN MILLIMETERS

	3.2/1.6/0.8
154 H7	+0.040 0
28 JS9	±0.026
7 JS10	±0.029

TOLEARANCE SHOULD BE STRICTLY MAINTAINED.

SL. No.	R	MATERIAL CODE No.	WT.Kg
01	20	69 12 51 009 4	27.5
02	24	69 12 51 054 1	26.1
03	35	69 12 51 055 9	21.1
04	15	69 12 51 110 8	28.3
05	28	69 12 51 111 6	24.8
06	12	69 12 51 110 2	29.1

CAUTION: THE INFORMATION ON THIS DOCUMENT IS THE PROPERTY OF BHARAT HEAVY ELECTRICALS LTD IT MUST NOT BE USED DIRECTLY OR INDIRECTLY IN ANYWAY DETERMINAL TO INTEREST OF THE COMPANY

SL No.	MATERIAL	CHEMICAL COMPOSITION									
		C	Si	Mn	Cr	Mo	V	W	S	P	Co
01	X165CrV12 (DIN 1.2201)	1.55 1.75	0.25 0.40	0.20 0.40	11.00 12.00	-	0.07 0.12	-	0.035Max.	0.035Max.	-
02	XT160Cr12 (IS:3748-1990)	1.50 1.70	0.10 0.35	0.25 0.55	11.00 13.00	0.80Max.	0.80Max.	0.60Max.	0.035Max.	0.035Max.	-
03	D2 (AISI/SAE)	1.40 1.60	0.30 0.50	0.30 0.50	11.00 13.00	0.70 1.20	0.80Max.	-	-	-	0.60Max.

ANY ONE OF THE MATERIALS LISTED ABOVE SHALL BE USED

HARDENESS 50-54 HRC

MARK R VALUE & MATERIAL CODE No, PO/RO No, ROLL SL No & FIRMS NAME

SUPPLY TO BE ASPER TDC/TE/MFG-06

REV 11	DATE 09/10/13	ALTERED CHECKED APPROVED	<i>N. A. Nairan</i>	REV 10	DATE 15/12/08	ALTERED CHECKED APPROVED	<i>P. Suresan</i>
SI.No.:06 R12 ADDED PARALLELISM 0.05 ADDED				MATERIAL XT160Cr12&D2 ADDED			

	Bharat Heavy Electricals Ltd		DRN	R.KUMAR	NAME	<i>R. Kumar</i>	DATE	09/10/13
	SEAMLESS STEEL TUBE PLANT		CHD	N ARUMUGANAINAR	NAME	<i>N. Arumuganainar</i>		
	TIRUCHIRAPALLI - 620014		APPD	M. MARUDHAVANAN	NAME	<i>M. Marudhavanan</i>	DATE	09/10/13
DEPT	GRADE OF UNTO. DIM	SCALE	WEIGHT (Kg)	REF TO ASSY DWG NO		ITEM NO		
CODE	C/M/F	1:1		REF TO OLD DWG NO		20.....160/05		
TITLE			CARD CODE	DRAWING NO :		REV		
STEEL ROLL (S R M 300)			U 01	20-ST-115-02-160		11		

Product : **SRM ROLLS**

Document No.	Revision No.	Effective Date	Page No.
TDC/TE/MFG- 06	04	26.08.2010	1 of 2
Revision Record	04 – Clause 3.4 : modified Clause 7.1 : liquid penetrant test details added Clauses 6.0 – 11.0 rearranged & renumbered to 6.0 – 10.0 Clause 8.0 : modified		

1.0 PRODUCT:

Sl.No.	Equipment / Product	Drg. No.	Drg. Rev. No.
1.	Steel Roll SRM 300	20.ST.115.02.160	AS PER LATEST ENQUIRY / PURCHASE ORDER
2.	Steel Roll SRM 380	20.ST.115.01.157	

2.0 APPLICATION:

Used in Stretch Reducing Mill Stands - for Hot Rolling of Seamless Steel Tubes in Temperature 850 - 900 Deg.C

3.0 MATERIAL:

- DIN 1.2201 – X165Cr.V12 (OR) SAE J438(70) D2 (OR) IS:3748-1990 XT160Cr12**
- Conduct Ultrasonic Test on Raw Material after proof machining in accordance with SA 388.
- Acceptance Standard in accordance with AM 203.2(c), ASME Sec VIII Div.2.
- Chemistry : As per drawing
Original mill test certificate shall be provided. Otherwise copy of original mill test certificate and test report from **NABL accredited lab** for chemical check on sample from the procured material shall be provided.

4.0 DIMENSIONS AND TOLERANCE:

Shall be as per Drawing

5.0 HEAT TREATMENT:

Sl.No.	Process	Detail
1.	Stress Relieving	650-705 Deg.C 2 Hours / 25mm Soaking Slow cooling to 500 Deg.C Air Cool
2.	Hardening	980-1025 Deg.C 1 Hour / 25mm Soaking
3.	Oil Quenching	80 Deg.C (Servo Quench 11)
4.	Tempering – I	470-580 Deg.C 3-4 Hrs. Soaking Air Cool to Hand-warm Temperature (about 50 Deg.C)
5.	Tempering – II	530-550 Deg.C 1 Hour / 25mm Soaking

6.0 INSPECTION & TESTING:**6.1 DIMENSIONAL INSPECTION :**

Dimensional inspection shall be carried out by the supplier and report for the same shall be sent along with the supplies – Acceptance as per drawing.
Air gap to be checked using template and the same shall be given by SSTP/BHEL on placement of order

BHEL, Tiruchirapalli-620014	SSTP / Tool Engineering	Technical Delivery Conditions	
Product : SRM ROLLS			
Document No.	Revision No.	Effective Date	Page No.
TDC/TE/MFG - 06	04	26.08.2010	2 of 2

6.2 MECHANICAL TESTING:

1. Hardness Test as per **DIN EN ISO 6508-1** FOR X165CrV12 - Acceptance as per Drawing.
2. Hardness Test as per **SAE J438(70)** for D2 - Acceptance as per Drawing.
3. Hardness Test as per **IS:3748-1990** for XT160Cr12 - Acceptance as per Drawing.

7.0 NON-DESTRUCTIVE TEST :

7.1. Liquid Penetrat Test :

To be conducted on entire surface after finish machining as per **ASTM E165** and shall be certified by **NDT Level II qualified personnel as per SNT-TC-1A.**

Acceptance standards : All surfaces to be examined shall be free of,

1. Relevant linear indications,
2. Relevant rounded indications greater than 3/16 inch (5 mm)
3. Four or more relevant rounded indications in a line separated by 1/16 inch (1.5 mm) or less, edge to edge.

8.0 TEST CERTIFICATE/REPORT :

Following test certificates shall be sent with Materials.

PO No., component name, TDC NO. and drawing no. shall be mentioned where ever applicable.

Traceability data like Heat / Melt No. & job Sl. No. shall be provided in all the reports.



1. Raw Material Chemistry (**Clause 3.4**)
2. Hardness (**Clause 6.2**)
3. Temperature-Time-Recorder Graph for the Heat Treatment Cycle followed
4. Ultrasonic Test Report for Raw Material (**Clause 3.2 & 3.3**)
5. Liquid Penetrant Test (**Clause 7.1**)
6. Dimension Report (**Clause 6.1**)

9.0 MARKING:

The marking shall be done on the job as shown in the Drawing.

10.0 PRESERVATION & PACKING :

1. Supply with rust preventive coating which shall be dry after application and removable by common solvents.
2. Pack suitably to avoid transit & handling damages

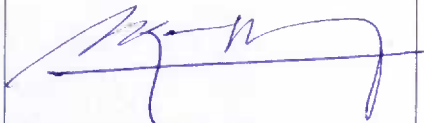
Prepared By	Reviewed By	Approved By
 DM / TE	 DGM / QA&C	 AGM / TE

Pre-Qualifying Criteria

1.The vendor should be a manufacturer/trader and should have completed supply of similar rolls to any of steel rolling mills in Central/State/Govt organisation/PSU Company/ Public Listed company. Documental evidence of both Purchase Order copy & Supply Completion of the same order like Delivery Challan/Tax Invoice/Payment Proof /Performance certificate to be furnished.	Submit Documental evidence
2.The Vendor should have the required machining, grinding facilities for carrying out the job and document for the same shall be attached with their offer. In case of a trader, documental evidence of valid technical tie up with the manufacturer and required machining, grinding facilities available with the manufacturer for carrying out the job shall be attached with their offer.	Submit Documental evidence

Without submission of Documental Evidence of the above, vendor offer shall be liable to rejection.

Abhighna
a D



Digitally signed
by Abhighna D
Date: 2023.11.30
12:28:26 +05'30'