

SCHEDULE 1

MANDREL HEAD-FOR MANDREL ASSY (20.228)

MANDREL HEAD-FOR MANDREL ASSY.

CPE DRAWING NO: 20. ST.123.02.228/01

SERIAL NO: 2

3.2/ 1.6/

DEVIATIONS OF UNTOLERANCED DIMENSIONS TO BE AS PER IS:2102-1969 MEDIUM

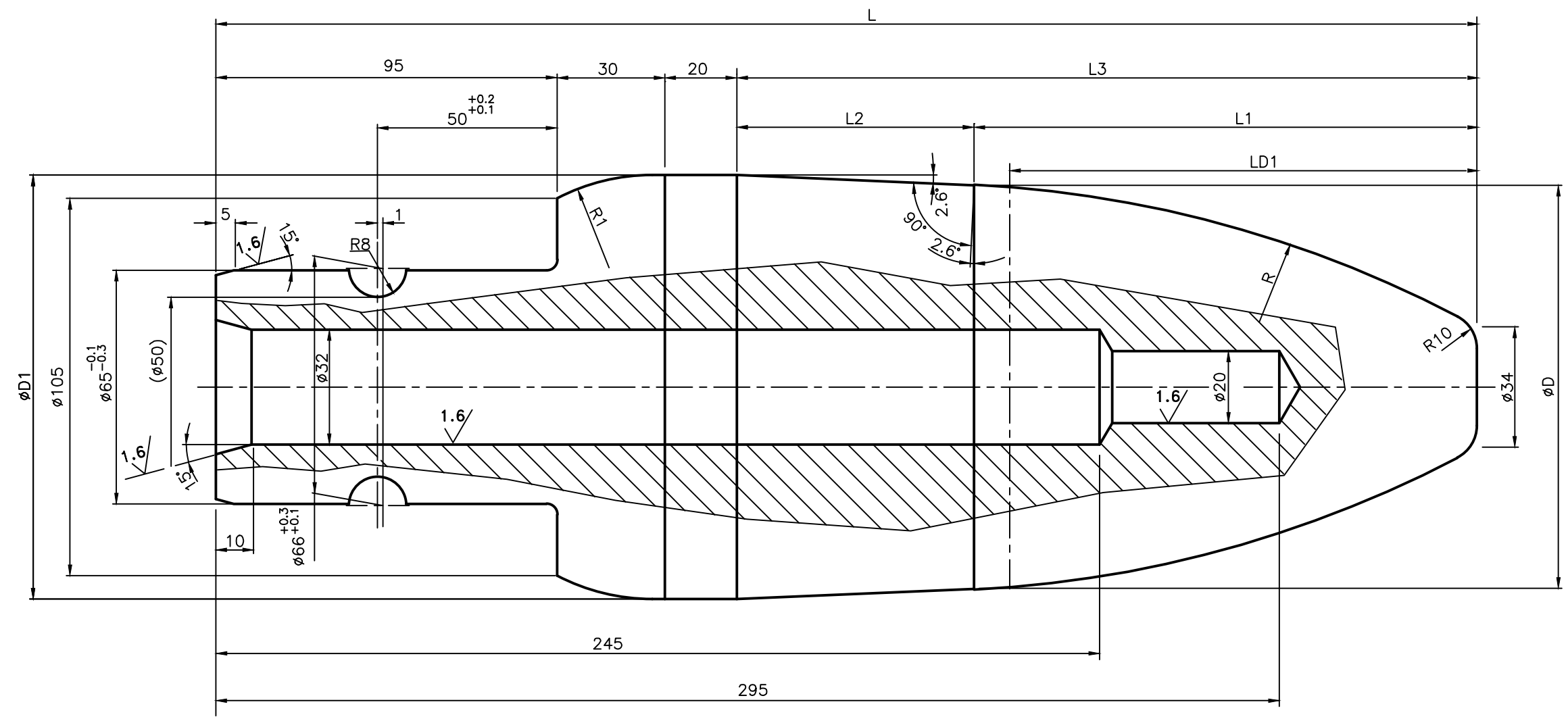

CHEMICAL COMPOSITION FOR G17CrMo9-10(1.7379)

C	Si	Mn	Ni	P	S	Cr	Mo	V	Cu
0.13	MAX.0.6	0.5	MAX.0.4	MAX.0.02	MAX.0.02	2.0	0.9	MAX.0.05	MAX.0.3
0.20		0.9				2.5	1.2		

HARDNESS 28-32 HRC

SL No.	ØD	ØD1	L	L1	L2	L3	R	R1	Wt(Kg)	MATERIAL CODE No.
01	112.01	118	351.19	140.19	66	206.19	324.73	114.50	16.8	6905123201
02	109.55	115	355.89	150.89	60	210.89	391.58	181.25	16.1	6905123202
03	109.55	112	371.72	166.72	60	226.72	507.64	46.41	15.9	6905123203

REV	DATE	ALTERED
01	11.12.12	APPROVED N. A. Nainan
Ø32HOLE LENGTH 245ADDED		
Ø20HOLE LENGTH50(295)ADDED		

CAUTION: THE INFORMATION ON THIS DOCUMENT IS THE PROPERTY OF BHARAT HEAVY ELECTRICALS LIMITED. IT MUST NOT BE USED DIRECTLY OR INDIRECTLY IN ANY WAY DETRIMENTAL TO THE INTEREST OF THE COMPANY.	(DIN 1.7379) G17CrMo9-10		MATL CODE UNIT WT	
	MATL SPEC QTY		EQPT:	
	DEPT: SSTE GRADE OF UNTOL. DIM: $\phi/M/f$ CODE: 456 IS: 2102		SCALE: 1:1 WEIGHT (Kg): 15.9 TO 16.8	
	TITLE: MANDREL HEAD		DRAWING NO: 20-ST-123-02-228 REV: 01	

BHARAT HEAVY ELECTRICALS LTD SEAMLESS STEEL TUBE PLANT TIRUCHIRAPALLI - 620014	DRN	R. KUMAR	SIGNATURE	DATE
	CHD	N. ARUMUGANAINAR	N. A. Nainan	24.09.11
	APPD	S. KARUPPASAMY	S. Karuppasamy	