

SCHEDULE 1

TIRE-FOR ROLL HOLDER ASSY (20.231/00)

TIRE-FOR ROLL HOLDER ASSY.

CPE DRAWING NO: 20. ST.123.03.231/01

DRAWING NO: 20-ST-123-03-231

ALL DIMENSIONS ARE IN MILLIMETERS

1.6/ 0.8/

DEVIATIONS OF UNTOLERANCED DIMENSIONS TO BE AS PER IS:2102-1969 MEDIUM

1400 H7 +0.125
0

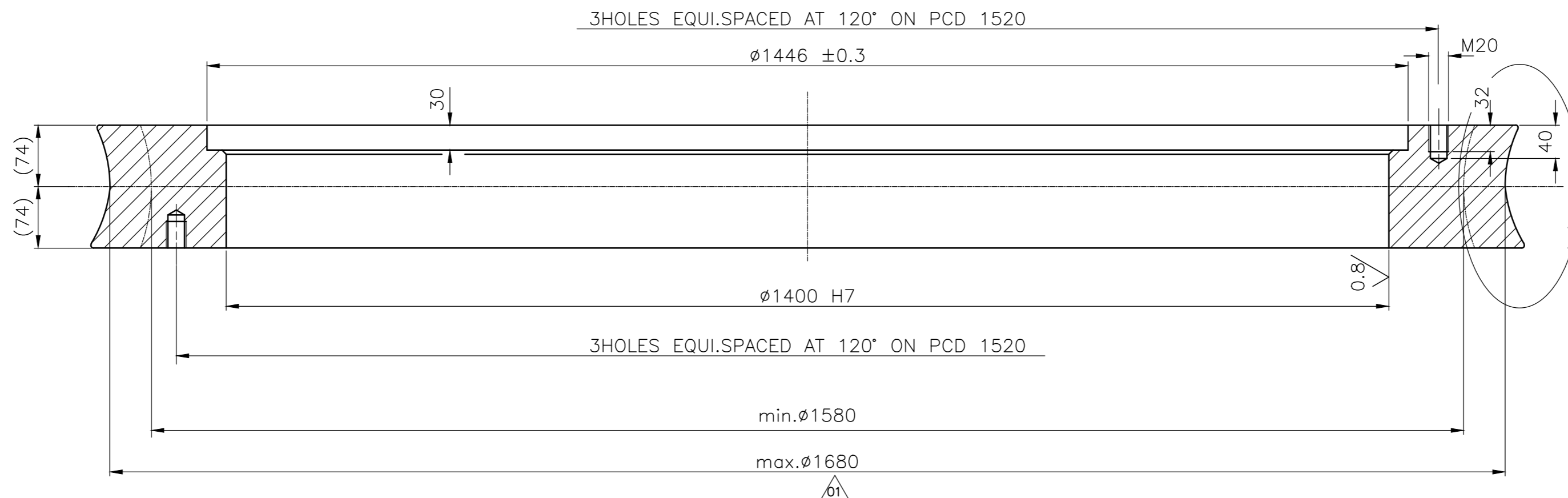

DETAIL-X

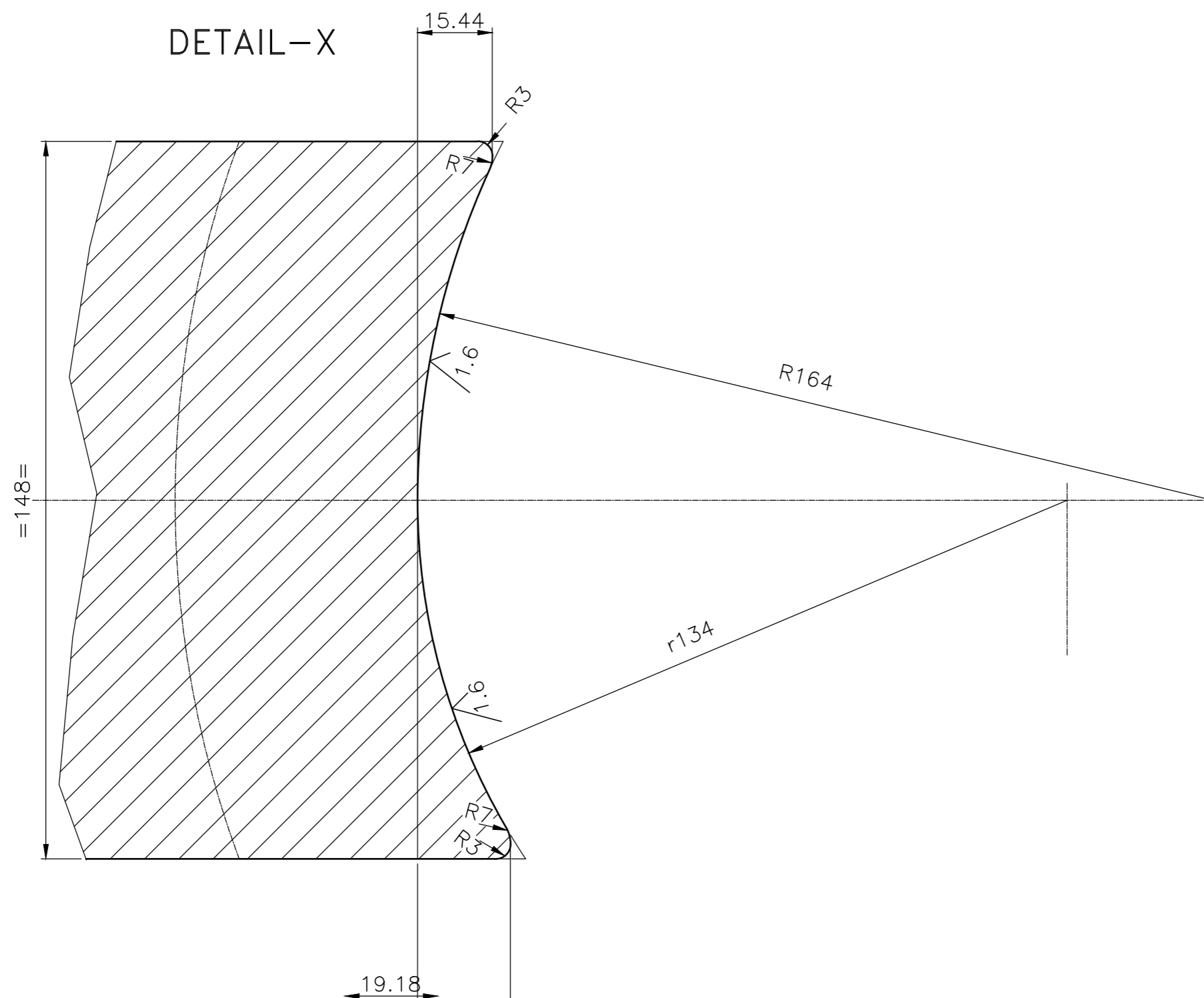

MATERIAL: SPHEROIDAL GRAPHITE CAST IRON
 CHEMICAL COMPOSITION:-

C	Si	Mn	Cr	Ni	Mo	P	S
3.0	1.4	0.3	0.3	1.0	max.0.2	max.0.1	max.0.015
3.5	2.2	0.8	0.8	2.0			

SURFACE HARDNESS 340-380 HV
 TENSILE STRENGTH 400-500 N/mm²

MATERIAL CODE No.:6905123305

ITEM NO	DESCRIPTION	DRAWING NO	S G IRON		
			MATL CODE	UNIT WT	
			MATL SPEC	QTY	
EQPT:					
Bharat Heavy Electricals Ltd SEAMLESS STEEL TUBE PLANT TIRUCHIRAPALLI - 620014		DRN	R.KUMAR	SIGNATURE <i>R.Kumar</i>	DATE 24.10.11
		CHD	N ARUMUGANAINAR	SIGNATURE <i>N. Arumuganainar</i>	
		APPD	S KARUPPASAMY	SIGNATURE <i>S. Karuppasamy</i>	
DEPT SSTP	GRADE OF UNTOL. DIM G/M/F IS:2102	SCALE 1:5 1:1	WEIGHT (Kg) 796.3	REF TO ASSY DWG NO (10.....172&173)	ITEM 05
max.Ø1980 REVISED TO max.Ø1680 AS INDICATED.		REF TO OLD DWG NO 0101056-06.801		DRAWING NO : 20-ST-123-03-231	
TITLE TIRE		CARD CODE U 01	REV 01		

CAUTION: THE INFORMATION ON THIS DOCUMENT IS THE PROPERTY OF BHARAT HEAVY ELECTRICALS LIMITED. IT MUST NOT BE USED DIRECTLY OR INDIRECTLY IN ANY WAY DETRIMENTAL TO THE INTEREST OF THE COMPANY.