



**BHARAT HEAVY ELECTRICALS LIMITED
SOLAR BUSINESS DIVISION, BENGALURU
TENDER DOCUMENT**

**Name: Premnaraian Srivas
Designation: Engineer
BHEL SBD Bangalore**



NOTICE INVITING TENDER

1. BHEL/ SBD (A Govt. of India Enterprise) invites Tender for engaging a Contractor for **“Works contract for construction of foundation for calciner chimney at BHEL-SBD Bengaluru.**
2. The Enquiry/Tender has been floated through e-procurement and offers shall be accepted through e-procurement only. BHEL shall neither entertain offers through hard copy nor provide any due date extension on account of the same. Interested bidders who do not have login ID and password are requested to register themselves on <https://eprocurebhel.co.in> through “Online Bidder Enrolment” link available on the portal.
3. Class-III, SHA2 2048 BIT – Signing & Encryption, Digital Signature Certificate (DSC) is required for bidders for authentication purpose (log in and bid submission). Vendors, who do not possess the DSC, are requested to obtain the same. The procedure for obtaining DSCs is detailed in the “Seller Manual” available on the above mentioned website.

Tender Ref No. 191184

Date: 11.02.2022

For all clarifications/ issues related to the tender, please contact:

(i) Commercial:

Mr. Premnaraian Srivas Engineer /Works Contracts cell, BHEL-SBD,
Prof CNR Rao Circle, IISc Post, Malleswaram, Bangalore- 560 012

E-MAIL: pnsrivias@bhel.in

Ph. No. +91-080-22182344 Or

Mr. Pradipchandra Baro SDGM / Works Contract Cell, BHEL-SBD,
Prof CNR Rao Circle, IISc Post, Malleswaram, Bangalore- 560 012

E-MAIL: pradipcbaro@bhel.in

Ph. No. +91-080-22182142

(ii) Technical:

Mr. **Preetam Kumar Singh**, Dy.Engineer / WEX BHEL-SBD

BHEL-SBD, Prof CNR Rao Circle, IISc Post, Malleswaram, Bangalore- 560 012

E-MAIL: preetam@bhel.in

Ph. No. +91-080-22182216



BHARAT HEAVY ELECTRICALS LIMITED
Solar Business Division, Malleswaram,
Bengaluru - 560 012

TENDER DOCUMENT
(PART – A)

TENDER DOCUMENT
PART – A
VOLUME - I

1.	GENERAL INFORMATION
2.	SCOPE OF WORK
3.	ELIGIBILITY CRITERIA
4.	PAYMENT TERMS
5.	ANNEXURES



BHARAT HEAVY ELECTRICALS LIMITED
Solar Business Division, Malleswaram,
Bengaluru - 560 012

TENDER DOCUMENT
(PART – A)

1.		General Information
1.1.	Tender Reference Number :	191184 Date: 11.02.2022
1.2.	Tender Name:	Works contract for construction of foundation for calciner chimney at BHEL-SBD Bengaluru.
1.3.	Tender System	Single Stage, Two Part Bid Part – A: Techno-Commercial & PQR Part – B: Price Bid
1.4.	Tender Type	Open Tender- Works contract for construction of foundation for calciner chimney / Works contract
1.5.	Estimated Value of Contract	Rs.1,98,576.00 Plus applicable GST
1.6.	Duration of Contract	01 Month (from Work Order placed/Handover of site)
1.7.	Qualifying Requirement	As per PQC of NIT
1.8.	Earnest Money Deposit to accompany Tender	Rs.4000.00 (Mandatory for MSME also) for works contract
1.9.	Security Deposit	(03% of Work Order value)
1.10.	Cost of Tender documents	NIL
1.11.	Issue of tender documents	As per Enquiry / RFQ / Notification on www.bhel.com & https://eprocurebhel.co.in
1.12.	Pre- BID Meeting	As per Enquiry / RFQ / Notification on www.bhel.com & https://eprocurebhel.co.in
1.13.	Last date for Issue of tender documents	As per Enquiry / RFQ / Notification on www.bhel.com & https://eprocurebhel.co.in
1.14.	Last date for submission of tender doc	As per Enquiry / RFQ / Notification on www.bhel.com & https://eprocurebhel.co.in
1.15.	Date and time of opening of Tender (Part-A)	As per Enquiry / RFQ / Notification on www.bhel.com & https://eprocurebhel.co.in
1.16.	Tender Submission Place	Online at https://eprocurebhel.co.in
1.17.	Tender Opening Place	Online at https://eprocurebhel.co.in
1.18.	Dealing Officer (For any Clarifications)	Mr. Premnaraian Srivas Engineer /Works Contracts cell, BHEL-SBD, Prof CNR Rao Circle, IISc Post, Malleswaram, Bangalore- 560 012 E-MAIL: pnsrivas@bhel.in Ph. No. +91-080-22182216 Or Mr. Pradipchandra Baro SDGM / WEX & Works Contract Cell, BHEL-SBD, Prof CNR Rao Circle, IISc Post, Malleswaram, Bangalore- 560 012 E-MAIL: pradipcbaro@bhel.in Ph. No. +91-080-22182142
1.19.	Revers Auction	"BHEL shall be resorting to Reverse Auction (RA) (Guidelines as available on www.bhel.com) for this tender. RA shall be conducted among the Techno-commercially qualified bidders in line with new RA guideline-2021. Price bids of all techno-commercially qualified bidders shall be opened and same shall be considered as initial bids of bidders in RA. In case any bidder(s) do(es) not participate in online Reverse Auction, their sealed envelope price bid along with applicable loading, if any, shall be Considered for ranking."
2.	SCOPE OF WORK: Construction of RCC foundation for chimney of SCR calciner as per drawing provided.	
2.1.	Details as per Annexure- I.	



3.	ELIGIBILITY CRITERIA
3.1.	1. Pre-Qualification requirement: Bidders should have Experience “Civil work” executed during last Seven years. Start-ups registered with DIPP are exempted to fulfill the criteria of minimum turnover and minimum years of experience after providing prescribed certificate issued by the govt. of India.
3.2.	<u>Average Annual Financial turnover</u> during the last 3 financial year ending 31st March., should be at least Rs.70,300/- which is 30% of (NIT displayed value + applicable GST 18%). Audited Balance sheet and profit& Loss account OR Turn over Certificate from Chartered Accountant to be enclosed for the last 3 financial year ending 31st March.
3.3.	Bidders who wish to participate should have executed works of similar nature during last three years as per Given below, as on the date of opening of Technical Bid. i. Three similar completed work - “Civil work” each costing not less than an amount equal to Rs.93,800/- which is 40% of (NIT displayed value + applicable GST 18%). (OR) ii. Two similar completed work - “Civil work” each costing not less than an amount equal to Rs.1,17,200/- which is 50% of (NIT displayed value + applicable GST 18%). (OR) iii. One similar completed work - “Civil work” each costing not less than an amount equal to Rs.1,87,500/- which is 80% of (NIT displayed value + applicable GST 18%). Bidder to submit relevant documents as proof of completion or execution of work like PO/WO/bills/work completion certificate to establish that amount of work is completed. a. The term ‘executed’ means the bidder should have achieved the criteria specified in the PQR even if the total contract has not been completed or closed. b. Bidder should not have been banned by “any BHEL unit” or “Government of India” or “Government of Karnataka” or Government of other states in India. BHEL reserves the right for independent verification of Documents.
3.4.	The bidder shall also mention the PAN Number issued by Income Tax Department, copy of the PAN card or PAN number allotment letter shall be submitted along with the tender documents.
3.5.	There should be no litigation or charge under investigation / enquiry / trial against the Tenderer, or conviction in a court of law or suspension or blacklisting by any organization on any ground. During the course of work, if any such information comes to light, the contract may be terminated.
3.6.	The opinion / decision of BHEL regarding the bid shall be final and conclusive. BHEL reserves the right to reject any or all the bids at any time without assigning any reason.
3.7.	In case the bidder has a relative employed in BHEL, the authority inviting tender shall be informed of this fact in writing at the time of submission of tender, failing which the tender may be disqualified, or if such fact comes to light subsequently, the contract may be terminated.
3.8.	If the bidder gives wrong information in his tender or creates conditions favorable for the acceptance of his tender, BHEL reserves the right to reject such tender at any stage.
3.9.	BHEL reserves the right to cancel the contract at the initial stage or during the contract period without assigning any reason to the tenderer.
4.	PAYMENT TERMS
4.1.	100% On completion of all work. The contractor shall raise the bill for payment as per the contractual terms & conditions mentioned in the contract, which should be duly certified by the BHEL official in charge of the contracted work.
4.2.	GST will be reimbursed to the contractor after the contractor pays GST, files return and submits a proof of the same to BHEL.
4.3.	As this is a works contract, Income tax deduction at source (TDS) at the applicable rate (prevailing rates as applicable at the time of clearance of bills) shall be recovered and remitted to Govt. of India. Income tax deduction certificate shall be issued for the amount of Income Tax deducted. Income Tax TDS as applicable and GST TDS @ 2% will be done.



BHARAT HEAVY ELECTRICALS LIMITED
Solar Business Division, Malleswaram,
Bengaluru - 560 012

TENDER DOCUMENT
(PART – A)

5	Annexures
5.1	Detailed Scope of Work – Annexure I
5.2	Techno-commercial Bid Application – Annexure II
5.3	Bidder Information – Annexure III
5.4	Qualification Requirement – Annexure IV
5.5	Declaration by Bidder-I – Annexure V
5.6	Declaration by Bidder-II – Annexure VI
5.7	Deviations Sheet- Annexure VII
5.8	Unpriced BID and HSN / SAC Codes - Annexure -VIII
5.9	PPP-MII Format- Annexure- IX
5.10	Border Sharing- X



BHARAT HEAVY ELECTRICALS LIMITED
Solar Business Division, Malleswaram,
Bengaluru - 560 012

TENDER DOCUMENT
(PART - A)

5.1 ANNEXURE - I

SCOPE OF WORK: Construction of RCC foundation for chimney of SCR calciner as per drawing provided.



BHARAT HEAVY ELECTRICALS LIMITED
Solar Business Division, Malleswaram,
Bengaluru - 560 012

TENDER DOCUMENT
(PART – A)

5.2 ANNEXURE – II TECHNO-COMMERCIAL BID APPLICATION

To,

Engineer / WC
Bharat Heavy Electricals Limited
Solar Business Division,
IISc Post, Malleswaram,
Bengaluru – 560 012

Dear Sir,

I / We hereby offer to carry out the work “**Works contract for construction of foundation for calciner chimney.**”

I /We have carefully perused the all the clauses mentioned in NIT and agree to abide with the same.

1. Notice Inviting Tender – Part A Volume 1
2. Notice Inviting Tender – Part A Volume 2
3. Price Bid Format - Part – B

I/ We further agree to execute all the works referred to in the said documents.

I declare that, there was never / is no litigation or charge under investigation / enquiry / trial against me / us, nor conviction in a court of law or suspended or blacklisted by any organization on any grounds.

Signature of Tenderer

Date:



5.3 ANNEXURE – III: BIDDER INFORMATION

Sl. No.	DETAILS REQUIRED	Requirement fulfilled (Yes / No / NA/ Value)
1	Name of the Company	
2	Constitution of Firm	Individual / Sole Proprietorship Concern / Partnership Firm / Public Ltd. Company/ Private Ltd. Company.
3	Name of Authorized Signatory	
4	Name of Contact person for this tender	
5	Email-id of contact person	
6	Contact number	
7	Bank Account Details (Name of Bank, Branch and Account Number). Cancelled Cheque to be enclosed	
8	Details of Relatives employed in BHEL, Name Designation and Unit - Clause 3.7	
	Relative 1	
	Relative 2	
	Relative 3	



5.4 ANNEXURE – IV: QUALIFICATION REQUIREMENTS

S. No.	DETAILS REQUIRED	Requirement fulfilled (Yes / No / NA/ Value)	Whether proof / document enclosed (YES / NO)
1	Compliance to Clause 3.1		
2	Average turnover of last 3 years - Clause 3.2		
3	Relevant Work Experience as per Clause 3.3 –1		
	Relevant Work Experience – 2		
	Relevant Work Experience – 3		
4	PAN No. - Clause 3.2 (copy to submitted)		
5	GST Registration Number (copy to submit)		
6	ESI Registration Number (copy to submit)		
7	PF Registration Number (copy to submit)		
8	MSEs / NSIC-UDYAM Certificate to be enclosed (if applicable)		
9	Start-Ups Certificate to be enclosed (if applicable)		
10	The bidder should encourage to use local labor that has the necessary skills as per the Requirement of work.		



5.5 ANNEXURE – V: BIDDER DECLARATION - I

S. No.	DETAILS REQUIRED	Requirement fulfilled (Yes / No / NA/ Value)
1	I have completely understood the scope of work and submit my agreement to carry out the work as per mentioned in Tender document.	
2	I have quoted rates for the total scope of work mentioned in the tender document	
3	I agree to participate in the Reverse Auction as per Tender Terms and Conditions	
4	I have understood and accepted the payment terms of BHEL as per Cl.4	
5	I am responsible for the safety of workmen deployed and agree to fulfil the requirements as per tender terms	
6	I have understood the LD clause mentioned in this tender and submit my agreement for the same.	
7	I agree to participate in the tender and carry out the work (if awarded) ethically and submit my agreement to various requirements in this contract.	
8	I have carefully read the Tender Terms and Conditions and I submit my agreement for the same.	
9	Signed and submitted the deviations sheet	

Signature with Name & seal of the Tenderer]



5.6 ANNEXURE – VI, BIDDER DECLARATION - II

I, -----, aged-----Yrs., S/o -----,

Residing at -----

Hereby declare as follows:

- (i) That my nationality is _____.
- (ii) That I am a major and eligible to enter into contract / my firm / my company is competent to enter into an agreement.
- (iii) I shall employ only such personnel who have not been found unfit for employment in Organizations such as Central / state / Public undertaking by the Police Authorities.
- (iv) I shall not employ persons against whom Criminal cases are pending or under investigation.
- (v) I shall also not employ persons found guilty of offences involving moral turpitude for executing work in BHEL contracts.
- (vi) That there are no Criminal cases/Civil/Labor pending or under investigation against me or my firm or company.
- (vii) I have not been found guilty of offences involving moral turpitude nor any of the company directors / partners of my firm have been found guilty of offences involving moral turpitude.
- (viii) Neither I nor my firm nor my company has been declared insolvent in the past.
- (ix) I have taken due care and efforts to furnish only information which are true in the tender document.
- (x) I shall employ labor who is more than 18 years of age and less than 58 years and having sound physical and mental health.
- (xi) I shall keep Photograph / identity proof / residential proof of the laborers to be employed against this tender and arrange for police verification.
- (xii) I shall employ and deploy suitable qualified personnel for supervision of the work in each shift and additionally as required for monitoring compliance to process requirements and compliance to contract terms & conditions.

[Signature with Name & seal of the Tenderer]

Date :

Place :



BHARAT HEAVY ELECTRICALS LIMITED
Solar Business Division, Malleswaram,
Bengaluru - 560 012

TENDER DOCUMENT
(PART – A)

5.7 ANNEXURE VII: DEVIATION SHEET

Sl. No.	Volume	Part/Clause Sl no.	NIT requirement	Bidder's Deviation

Total No. of deviations proposed by the Bidder- _____ nos. /Nil.

BIDDER'S SIGN & SEAL

Note: The Offers should be in full conformity with the terms and conditions of this tender. Incorrect and incomplete tenders are liable to be rejected. Deviations, if any, should only be mentioned in DEVIATION SHEET only for Non-Technical Deviations (i.e. General Terms & Conditions, Commercial Terms etc.) & Technical Deviations (i.e. Scope of Work, Modalities of Contract etc.). BHEL at its discretion whether to give any further chance to a bidder in case of any deviation or reject the same offer.



5.8 Annexure-VIII– Unpriced Bid

Validate		Print		Help		Percentage BoQ	
Tender Inviting Authority: B.M.Hiremani (AGM-BHEL SBD)							
Name of Work: Works contract for construction of foundation for calciner chimney at BHEL-SBD Bengaluru.							
Contract No: 187960							
Name of the Bidder/ Bidding Firm / Company :							
PRICE SCHEDULE							
<small>(This BOQ template must not be modified/replaced by the bidder and the same should be uploaded after filling the relevant columns, else the bidder is liable to be rejected for this tender. Bidders are allowed to enter the Bidder Name and Values only)</small>							
NUMBER #	TEXT #	NUMBER #	TEXT #	NUMBER	NUMBER #	TEXT #	
Sl. No.	Item Description	Quantity	Units	Estimated Rate in Rs. P	TOTAL AMOUNT Without Taxes in Rs. P	TOTAL AMOUNT In Words	
1	2	4	5	6	53	55	
1	Construction of foundation for calciner chimney						
1.01	Demolishing R.C.C. work manually/ by mechanical means including stacking of steel bars and disposal of unserviceable material within 50 metres lead as per direction of Engineer - in-charge.	27.490	Cum	2481.510	68216.710	INR Sixty Eight Thousand Two Hundred & Sixteen and Paise Seventy One Only	
1.02	Dismantling steel work in built up sections in angles, tees, flats and channels including all gusset plates, bolts, nuts, cutting rivets, welding etc. including dismembering and stacking within 50 metres lead.	300.000	KG	3.940	1182.000	INR One Thousand One Hundred & Eighty Two Only	
1.03	Earth work in excavation by mechanical means (Hydraulic excavator)/ manual means over areas (exceeding 30 cm in depth, 1.5 m in width as well as 10 sqm on plan) including getting out and disposal of excavated earth lead upto 50 m and lift upto 1.5 m, as directed by Engineer-in-charge. Ordinary rock	25.960	Cum	349.970	9085.221	INR Nine Thousand & Eighty Five and Paise Twenty Two Only	
1.04	Supplying and filling in plinth with sand under floors, including watering, ramming, consolidating and dressing complete.	0.960	Cum	1831.525	1758.264	INR One Thousand Seven Hundred & Fifty Eight and Paise Twenty Six Only	
1.05	Providing and laying in position cement concrete of specified grade excluding the cost of centering and shuttering - All work up to plinth level : 1:4:8 (1 Cement : 4 coarse sand (zone-III) derived from natural sources : 8 graded stone aggregate 40 mm nominal size derived from natural sources)	1.440	Cum	5361.059	7719.925	INR Seven Thousand Seven Hundred & Nineteen and Paise Ninety Three Only	
1.06	Providing and laying in position specified grade of reinforced cement concrete, excluding the cost of centering, shuttering, finishing and reinforcement - All work up to plinth level : 1:1.5:3 (1 cement : 1.5 coarse sand (zone-III) derived from natural sources : 3 graded stone aggregate 20 mm nominal size derived from natural sources)	8.710	Cum	7088.306	61739.145	INR Sixty One Thousand Seven Hundred & Thirty Nine and Paise Fourteen Only	
1.07	Centering and shuttering including strutting, propping etc. and removal of form for Foundations, footings, bases of columns, etc. for mass concrete	9.800	Sqm	260.975	2557.555	INR Two Thousand Five Hundred & Fifty Seven and Paise Fifty Five Only	
1.08	Steel reinforcement for R.C.C. work including straightening, cutting, bending, placing in position and binding all complete upto plinth level. Thermo-Mechanically Treated bars of grade Fe-500D or more.	609.650	KG	75.974	46317.549	INR Forty Six Thousand Three Hundred & Seventeen and Paise Fifty Five Only	
Total in Figures					198576.369	INR One Lakh Ninety Eight Thousand Five Hundred & Seventy Six and Paise Thirty Seven Only	
Quoted Rate in Figures			Select		0.000	INR Zero Only	
Quoted Rate in Words					INR Zero Only		

Note: Bidder to quote only percentage in cells for column E-Rows 18 (Select + or -), and for column F-Rows 18 (quote percentage in numbers example- 5, 10, 10.5 etc.) only in the prescribed Price bid format uploaded as a PART-B through [e-procurement portal](#).

Step to quote- 1) Write name of the bidder, 2(Select + or -), 3) quote percentage in numbers, 4)Validate top left corner, 5)protect excel sheet with your password, 6)Save and close the excel sheet and upload the price bid in [e-procurement portal](#).

Note:- Quote applicable GST here in percentage:-

BIDDER'S SIGN & SEAL

LOCAL CONTENT UNDER PREFERENCE TO MAKE IN INDIA ORDER
Tender Ref No. 191184
Part-A



(To be submitted with the offer)

[Applicable for procurement value from Rs.5.00 Lac to Rs.10.00 Crore]

Self-certification giving the percentage of local content, in line with PPP-MII order, if applicable [to be submitted on the letter head of the issuer.]

Item Name: _____

Tender Enquiry No. :

Project: _____

Applicable percentage of Local Content.....

(Bidder to indicate local content in percentage)

We have read and understood the provisions of “Public Procurement (Preference to Make in India) Order, 2017” dated 15/06/2017, its revision dated 28/05/2018 and any subsequent modifications/Amendments, if any [hereinafter, “PPP-MII Order”] issued by Department of Industrial Policy and Promotion (DIPP), Ministry of Commerce and Industry, Government of India.

In line with the provisions of the PPP-MII Order,

We, M/s. [Enter the name of the Bidder] [Hereinafter, “Local Supplier”] submits self-certification to M/s. Bharat Heavy Electricals Limited [hereinafter, BHEL] regarding Local Content in Goods/Services/Works to be supplied by the Local Supplier _____

(Enter the name of the Equipment/Item for Project), wherein we have agreed to abide by the terms and conditions of the PPP-MII Order.

Details of location at which local value addition will be made is as follows:

Place of service (Name of work)

We also understand, false declarations will be in breach of the Code of Integrity under Rule 175(1)(i)(h) of the General Financial Rules for which a bidder or its successors can be debarred for up to two years as per Rule 151 (iii) of the General Financial Rules along with such other actions as may be permissible under law.

For and on behalf of,

Authorized Signatory

(With Company Seal & Signature)

Date:

Note: This is a guiding format. In case the bidder submits the certificate in a format different from the above, the same may be considered provided it meets the intent and purpose, as may be ascertained by BHEL.

TENDER DOCUMENT



PART – A
VOLUME - II

1.	INSTRUCTION TO BIDDER
2.	EARNEST MONEY DEPOSIT (EMD):
3.	SECURITY DEPOSIT (SD) :
4.	NON DISCLOSURE AGREEMENT
5.	CONFIDENTIALITY
6.	STATUTORY REQUIREMENTS
7.	MANPOWER
8.	PERIOD OF CONTRACT
9.	FAILURE TO COMPLY WITH CONTRACT
10.	SUB-CONTRACTING
11.	LAWS GOVERNING THE CONTRACT
12.	LEGAL JURISDICTION:
13.	DUTIES AND RESPONSIBILITIES OF THE CONTRACTOR:
14.	ARBITRATION & CONCILIATION:
15.	COMPENSATION:
16.	REVERSE AUCTION TERMS & CONDITIONS
17.	PENALTY/ LD FOR DELAYED DELIVERY
18.	CONCILIATION CLAUSE – Annexure IA
19.	MAKE IN INDIA CLAUSE
20.	FORMATS



1.1.	Tender is a two part bid system. The tender documents consist of Part - A and Part - B as detailed below: a. Part 'A': Techno-commercial Bid duly sealed and signed to be uploaded at the web-portal (bhel.eprocure.com) on or before the due date. b. Part 'B': Price Bid to be quoted in prescribed format available on web portal (bhel.eprocure.com) on or before the due date.
1.2.	Envelope 1: Tender Document, EMD and MSEs certificate a. Documents to be uploaded in Envelope 1: i. Earnest Money Deposit (EMD) either in the form of DD or UTR/NEFT/RTGS Number (if paid through EFT) at the space provided. Note: Original DD to be sent to the Dealing Officer mentioned NIT-page-4 b. Part 'A' Vol. I: Pre-Qualification Requirement (PQR) Duly completed tender documents volume 1 sign and Sealed. i. Each and every page of tender documents should be sealed signed. ii. Documents satisfying PQR/Eligibility Criteria as per relevant clause of NIT. iii. Any other documents as per Tender requirements. Note- The tenderer shall not indicate the price or rate in the PART-A: Volume I, PQR. c. Part 'A' Vol. II: Techno-commercial Bid. i. Duly completed tender documents volume II sign and Sealed. ii. Each and every page of tender documents should be sealed & signed by the tenderer iii. Any other documents as per Tender requirements. Note- The tenderer shall not indicate the price or rate in the PART-A Volume II: Techno-commercial bid. Envelope 2: Part 'B': Online Price-Bid. i. TO be submitted online.
1.3.	The tenderer shall expressly accept all the terms and conditions of the Tender. The tender which does not comply with the BHEL's Terms & Conditions may be rejected as Non-responsive/non-conforming and non-acceptable.
1.4.	The techno-commercial offer will be opened on the due date. The tenders meeting our techno-commercial requirements will be considered for online initial sealed bid auction at a later date for which eligible vendors will be intimated in due course.
1.5.	Bidders have to submit 'Process compliance form' (to the designated service provider) in the Reverse Auction. Non-submission of 'Process compliance form' by the agreed bidder(s) will be considered as tampering of the tender process and will invite action by BHEL as per extant guidelines for suspension of business dealings with suppliers/contractors (as available on www.bhel.com). However, if the same bidder again defaults on this count in any subsequent tender in the unit, it will be considered as fraud and will invite action by BHEL as per extant guidelines for suspension of business dealings with suppliers/contractors (as available on www.bhel.com)." Start price in the REVERSE AUCTION shall be as per Cl. No. 16.3. Business rule and event of auction will be furnished by our service provider. The terms and conditions specified herein are to be strictly adhered to for all the activities.
1.6.	The tender forms duly filled in all respects shall be signed on each page by the tenderer. Any alteration, erasing will render the tender invalid. Corrections, over writing, cutting(s) etc. are not permitted. All entries in the tender document should be in one ink. All the columns in the tender form should be filled without leaving any column blank in any page of the tender. In case any of the relevant columns are left blank, the tender can be rejected. However, alteration neatly carried out and duly attested over with the full signature of the tenderer is permitted.
1.7.	The tenderer should submit the tender documents intact without detaching any page or pages
1.8.	Before making the offer, the bidders are advised to carefully go through the NIT-terms and conditions and BHEL-GCC, which form part of the Agreement.
1.9.	Tender documents consisting of Part 'A' Volume I & II duly sealed and signed and Part 'B' shall be uploaded duly on or before the said due Date and Time.



BHARAT HEAVY ELECTRICALS LIMITED
Solar Business Division, Malleswaram,
Bengaluru - 560 012

TENDER DOCUMENT
(PART – A)

	Part 'A' Volume I & II of tender form i.e. PQR and Techno-commercial Bid will be opened on specified Tender Due Date and Time. Bidders who qualify the PQR & Techno-commercial Bid will be intimated to participate in R.A.
1.10.	BHEL reserves the right to assess the capacity and capability of the parties for pre-qualification. The company also reserves the right to accept or reject any or all the tenders or any part thereof at any stage of process without assigning any reason whatsoever. The company has no obligation to accept the lowest tender. Offer of the Tenderer if prima-facie found not comparable with the quantum of work envisaged and the bid is a desperate effort to be L1, then the offer is liable to be rejected. BHEL's decision in this regard shall be final and binding.
1.11.	PRICE BID – Price bid to be submitted as per required format available on web-portal https://eprocarebhel.co.in
1.12.	Contractor to ensure payment of Minimum Wages payable as per statutory provisions of the Appropriate Govt.,
1.13.	VALIDITY OF RATES: The rates quoted should be valid for <u>90 days</u> initially from the date of opening of the Techno-Commercial bid. (Part-A)
1.14.	The rates shall include the payments on account of Employee contribution to PF, PF Admin. Charges, EDLI, Employer contribution to ESI, Gratuity, Bonus as per statutory requirement, applicable taxes, as per the directives issued by BHEL from time to time.
1.15.	Rates should be quoted in Indian Rupees and Paisa only.
1.16.	BHEL reserves the right to reject any bid, which is technically unacceptable and unworkable. Further BHEL also reserves the right to reject any or all tenders without assigning any reasons thereof.
1.17.	BHEL reserves the right to cancel the contract at the initial stage or during the contract period without assigning any reason to the tenderer.
1.18.	Wherever prescribed formats are specified for the tenderers use, he shall use the same for making his Claims.
1.19.	Tender document should be complete in all respects.
1.20.	Successful tenderers shall enter into an Agreement on a non-judicial stamp paper of Rs.100/- as a token of having accepted the rates, terms and conditions of the contract as per the Proforma given by BHEL.
1.21.	The Offers should be in full conformity with the terms and conditions of this tender. No contradictions are acceptable. Incorrect and incomplete tenders are liable for rejection.
1.22.	Tenders not submitted in the prescribed forms are liable for rejection.
1.23.	BHEL reserves the right to accept or reject any tender in part or full at their discretion without assigning any reason.
1.24.	Eligible tenderers will be informed of reverse auction as per procedure as stated in the document.
1.25.	If a tenderer deliberately gives wrong information in his tender or creates conditions favorable for the acceptance of his tender, then BHEL reserves the right to reject such tender at any stage.
1.26.	If the tenderer indulges in any unethical practice for securing the contract, the offer of such tenderer shall be rejected.
1.27.	Any written communication required to be sent to the contractor in writing shall be sent at the address mentioned on the tender form or to any other address subsequently intimated by contractor in writing to BHEL SBD for the contract purposes.
1.28.	Benefit for MSEs bidders not available in this works contract. Micro & Small Enterprises (MSE) can avail the intended benefits only if they submit along with the offer, attested copies of either Udhyan Certificate or valid NSIC certificate along with attested copy of a CA certificate (where the Certificate is either expired or more than 5 years old) applicable for the relevant financial year (latest audited). Date to be reckoned for determining the deemed validity will be the date of bid opening (Part 1 in case of two part bid). Non-submission of such documents will lead to consideration of their bid at par with other bidders. No benefit shall be applicable for this enquiry if any deficiency is observed in the above required documents or all required documents are not submitted before price bid opening. If the tender is to be submitted through e-procurement portal, then the above required documents are to be uploaded on the portal. Documents should be notarized or attested by a Gazetted Officer.
1.29.	Evaluation of Bids



1.30.	Techno-Commercial Bid & PQR: The techno-commercial bid & PQR will be evaluated based on the eligibility criteria and on acceptance of NIT terms and conditions of BHEL. Only qualified bids will be eligible for price-bid opening / Reverse Auction.
1.31.	Evaluation of Price-Bids: i. Evaluation of the L-1 offer shall be computed on overall lowest cost to BHEL basis (Grand Total Price for all the items indicated in Price Bid minus tax credit, if, any) ii. In the event of two or more tenderers becoming L1, the said tenderers would be called for negotiation and will be instructed to submit fresh price bid offers. Further, in the event of two or more tenderers becoming L1, the selection of the tenderer for the purpose of awarding contract will be on the basis of LOTTERY to be held in presence of representatives of L1 tenderer
2.	EARNEST MONEY DEPOSIT (EMD):
2.1.	Earnest Money Deposit (EMD) is to be paid by tenderers for securing fulfilment of any obligations in terms of the NIT. Earnest Money Deposit as indicated in the NIT (Ref. General Information) is to be submitted along with tender documents Part – A.
2.2.	Modes of deposit The EMD may be accepted only in the following forms: (i) Cash deposit as permissible under the extant Income Tax Act (before tender opening) (ii) Electronic Fund Transfer/RTGS/NEFT/QR Code credited in BHEL account (before tender opening) (iii) Banker's cheque/ Pay order/ Demand draft, in favor of BHEL (Submitted originally before tender due date and time) Note:- In case total EMD amount is more than Rs.2.00 Lakh, the amount in excess of Rs.2.00 lakh may be accepted in the form of Bank Guarantee from scheduled bank. The Bank Guarantee in such cases shall be valid for at least six months.
2.3.	Forfeiture of EMD EMD by the Tenderer will be forfeited as per NIT conditions, if: i) After opening the tender and within the offer validity period, the tenderer revokes his tender or makes any modification in his tender which is not acceptable to BHEL. ii) The Contractor fails to deposit the required Security deposit or commence the work within the period as per LOI/ Contract EMD by the tenderer shall be withheld in case any action on the tenderer is envisaged under the provisions of extant "Guidelines on Suspension of business dealings with suppliers/ contractors" and forfeited/ released based on the action as determined under these guidelines.
2.4.	EMD given by all unsuccessful tenderers shall be refunded after awarding the work to successful bidder.
2.5.	EMD shall not carry any interest.
2.6.	EMD of successful tenderer will be retained as part of Security Deposit.
3.	SECURITY DEPOSIT (SD) :
3.1.	Security Deposit means the security provided by the Contractor towards fulfilment of any obligations in terms of the provisions of the contract. The total amount of Security Deposit will be <u>03% of the contract value</u> . EMD of the successful tenderer shall be converted and adjusted towards the required amount of Security Deposit.
3.2.	Bidder agrees to submit performance security required for execution of the contract within the time period mentioned. In case of delay in submission of performance security, enhanced performance security which would include interest (SB/ rate + 6%) for the delayed period, shall be submitted by the bidder. Further, if performance security is not submitted till such time the first bill becomes due, the amount of performance security due shall be recovered as per terms defined in NIT , from the bills along with due interest.
3.3.	Modes of deposit:



	<p>The amount to make up the required Security Deposit of 03% of the contract value may be accepted in the following forms:</p> <p>Cash (as permissible under the extant Income Tax Act)</p> <p>Local cheque of Scheduled Banks (subject to realization)/ Pay Order/ Demand Draft/ Electronic Fund Transfer in favor of BHEL</p> <p>Bank Guarantee from Scheduled Banks/ Public Financial Institutions as defined in the Companies Act. The Bank Guarantee format should have the approval of BHEL</p> <p>Fixed Deposit Receipt issued by Scheduled Banks/ Public Financial Institutions as defined in the Companies Act (FDR should be in the name of the Contractor, a/c BHEL)</p> <p>Securities available from Indian Post offices such as National Savings Certificates, Kisan Vikas Patras etc. (held in the name of Contractor furnishing the security and duly endorsed/ hypothecated/ pledged, as applicable, in favour of BHEL)</p> <p>(Note: <u>Timely submission of performance security deposit</u> "Bidder agrees to submit performance security required for execution of the contract within the time period mentioned. In case of delay in submission of performance security, enhanced <u>performance security</u> which would include interest (SB/ rate + 6%) for the delayed period, shall be submitted by the bidder. Further, if performance security is not submitted till such time the first bill becomes due, the amount of performance security due shall be recovered as per terms defined in NIT I contract, from the bills along with due interest"</p> <p>BHEL will not be liable or responsible in any manner for the collection of interest or renewal of the documents or in any other matter connected therewith)</p>
3.4.	<p>Collection of Security:</p> <p>At least 50% of the required Security Deposit, including the EMD, should be collected before start of the work. Balance of the Security Deposit can be collected by deducting 10% of the gross amount progressively from each of the running bills of the Contractor till the total amount of the required Security Deposit is collected.</p> <p>If the value of work done at any time exceeds the contract value, the amount of Security Deposit shall be correspondingly enhanced and the additional Security Deposit shall be immediately deposited by the Contractor or recovered from payment/s due to the Contractor.</p> <p>The recoveries made from running bills (cash deduction towards balance SD amount) can be released against submission of equivalent Bank Guarantee in acceptable form, but only once, before completion of work, with the approval of the authority competent to award the work.</p>
3.5.	<p>Security Deposit shall be released to the Contractor upon fulfilment of contractual obligations as per terms of the contract.</p>
3.6.	<p>The Security Deposit shall not carry any interest.</p>
4.	<p>NON DISCLOSURE AGREEMENT. The contractor shall sign a Non-Disclosure Agreement (NDA) as per BHEL format (Copy enclosed as per Format 20.3) in compliance to Information Security Management System.</p>
5.	<p>CONFIDENTIALITY: The contractor and his representatives shall, at all times, undertake to maintain and ensure complete confidentiality and integrity of all data, information, software, drawings & documents, etc. belonging to BHEL and also of the systems, procedures, reports, input documents, results and any other company documents discussed and/or finalized during the course of execution of the order/contract.</p>
6.	<p>STATUTORY REQUIREMENTS:</p>
6.1.	<p>While quoting the rate, the tenderers are advised to take note of minimum wages payable to workmen.</p>
6.2.	<p>The tenderer will be required to comply with all the statutory provisions such as Minimum Wages prevailing at the time of payment or arrears thereof Bonus, PF, EDLI, ESI, Applicable Tax, declared Holidays, leave, etc. The contractor shall submit the documentary evidence of payment on account of submission of statutory payments made to the concerned agencies before clearance of bill of next month.</p>
6.3.	<p>The Contractor shall comply with the provisions of the Factories Act 1948, Contract Labour (Regulation and Abolition) Act 1970, ESI Act, Employees Provident Fund and Miscellaneous Act 1952, Minimum Wages Act 1948,</p>



	Payment of Gratuity Act 1972, Industrial Disputes Act, 1947, Employers Liability Act 1938, Inter State Migrants Workmen (Regulation of employment and conditions of Service) Act 1979, Employees Compensation Act (...), Maternity Benefit Act 1961, and or any other Laws and Rules that may be applicable from time to time to the workers engaged by him. The contractor, when required by the Company shall produce the registers and records for verification and comply with other directions issued by the company for compliance of the statutory provisions.
6.4.	The contractor shall fully indemnify the loss if any caused to BHEL due to any default or non-observance of any of the laws, or any omission or commission or inability on the part of the contractor or his representative.
6.5.	The contractor shall, keep and produce for inspection at all times, forms, registers and other records required to be maintained under various statutes in order to enable scrutiny by the Company whenever required.
6.6.	The contractor shall produce to the Company, the documentary proof of payment of the said statutory dues. Non-observance of the provisions will be construed as default by the Tenderer in making such payment, and payment of his bill will be deferred.
6.7.	The Income tax as applicable will be deducted from the bill of the contractor. GST – TDS will be done @ 2% for all contracts with value above 2.5 Lakhs (excluding taxes).
6.8.	Each contractor will be required to maintain the daily attendance of his labors in the prescribed Performa for accounting payment of minimum wages, deduction towards ESI & PF Contributions, payment of Bonus, leave etc.
6.9.	The contractor will have to follow the provisions of Payment of Bonus Act 1965 and Rules 1975, and is liable to pay Bonus to his workers. However, the quantum of Bonus payable by the contractor to his workmen will be borne by BHEL. While quoting for the contract, the tenderer is required to quote bonus amount at minimum of @8.33%. Form C / D has to be submitted to BHEL for having disbursed the bonus.
6.10.	The contractor will have to extend paid National Holidays and Festival Holidays to their workmen as per the provisions of the relevant Act and the Rules thereof. However, if due to exigencies of work the contractor engages his workmen on National Holidays or Festival Holidays contractor shall pay additional wages as prescribed under the provisions of the Act.
6.11.	COMPLAINE WITH BOCW ACT: The contractor shall get registered and comply with the provisions of BOCW Act along with the allied rules and pay cess as per Cess Act along with allied rules. As applicable. The contractor shall also indemnify BHEL from all consequences/liabilities / penalties in case of non-compliance of the provisions of BOCW Act along with the allied rules and cess act.
7.	Manpower:
7.1.	The Contractor shall provide the minimum manpower required for executing the contracted work as per the scope of work. The contractor shall not engage a person who is less than 18 years of age and more than 58 years of age.
7.2.	Regarding Uniform, Washing Allowance and Safety shoes: The contractor at his own cost shall provide proper uniform and safety shoe including washing cost to their workmen. BHEL will not provide uniform, safety shoe and washing allowance to contractor. Contractor has to manage the same from the margin.
7.3.	The contractor shall be responsible for safety of his laborers while they are engaged for work connected with the Contract. The Contractor shall be responsible for the appropriate usage of the said safety appliances. In the event of violation of applicable safety, health & environment related norms, a penalty of Rs.500/- per occasion shall be imposed on the contractor.
7.4.	The contractor, as the employer of his workmen, shall manage them. In the event of any dispute arising between the contractor and his employees, the contractor alone is solely responsible for resolving the dispute between them and BHEL will in no way be responsible for settling the dispute either statutory or otherwise.
7.5.	The contractor will be solely responsible for executing the agreed work and the employees of BHEL will only oversee the proper execution of work. The contractor or his representatives shall be available in the factory to control and supervise his workers and take down instructions from the designated officials of BHEL. The cost of deployment of Supervisor has to be borne by the Contractor.



7.6.	The contractor shall have full control over his employees including w.r.t determining service conditions, discharge, dismiss, or otherwise terminate their services at any time. However, the contractor shall not engage any person who has completed 58 years of age. The contractor shall be solely responsible for any claim arising out of employment or termination of employment of his employees and for statutory payments.
7.7.	The contractor shall employ only such personnel who are medically fit. The company has right to direct the contractor to remove from the premises such of his personnel who may be physically, hygienically, clinically or medically unfit.
7.8.	The contractor shall employ only such personnel who have not been found unfit for employment in Organizations such as Central/State/Public Undertakings by the Police authorities. For this purpose, contractor is required to submit the police verification report before engaging the contract labor. Persons against whom criminal cases are pending or under investigation and persons found guilty of offences involving moral turpitude shall not be engaged for executing work.
7.9.	The Contractor shall comply with all the operational rules and regulations, including safety and security rules framed by the company from time to time wherein the Contractor or his workmen happen to be operating/ working. In the event of any of the workmen of the contractor violating any of the said rules and regulations, the Contractor would be required to remove forthwith such workmen from the company's premises.
8.	<u>PERIOD OF CONTRACT</u>
8.1.	Duration of contract is as mentioned in the General Information of NIT
8.2.	The contract shall be, initially, for the period as mentioned in NIT – General Information from the date of award of contract. The parties, if mutually agreed upon, may extend the period of contract for a further period on the same terms and conditions.
8.3.	The parties are at liberty to terminate the Agreement by giving three calendar months' notice in writing and the loss if any caused to the other party due to termination of contract shall be compensated by the party terminating it.
9.	<u>FAILURE TO COMPLY WITH CONTRACT</u>
9.1.	Notwithstanding anything contained in any other clause, BHEL reserves the right to terminate the contract due to any failure on the part of the Tenderer in discharging his obligations under the contract or in the event of his becoming insolvent or going into liquidation. The decision of the BHEL about the failure on the part of the Tenderer shall be final and binding on the tenderer.
9.2.	In case of any damage to the existing building, structures, materials, tools, furniture and fixtures, machines etc., caused from contractor's end, the cost of its repairs or replacement will be recovered from the contractor. If there is any work stoppage in any area of the Plant due to the fault of the tenderer, the tenderer is liable to compensate the same.
9.3.	In the event of any failure on the part of the tenderer, BHEL shall have the right without prejudice to any other right or remedies, to get the work done through any other agency and the Tenderer shall be liable to compensate BHEL for any losses on this account. The additional cost, loss, if any incurred by BHEL will be recovered from the bills, security deposits, other dues as well as directly from the Tenderer.
10.	<u>SUB-CONTRACTING</u>
10.1.	The contractor shall not sub-contract or transfer or assign the contract in full or any part thereof to any other person or firm or company without the previous express written approval of BHEL.
11.	<u>LAWS GOVERNING THE CONTRACT</u>
11.1.	The contract will be governed by the Laws of India for the time being in force and as amended or made from time to time.
11.2.	All disputes shall be settled in accordance with the Laws of India for the time being in force and as amended from time to time.
11.3.	All disputes arising out of or in relation to this contract or Agreement shall be settled by mutual discussions and in the event of failure such disputes shall be referred to the Arbitrator.



12.	LEGAL JURISDICTION:
12.1.	In respect of all matters arising out of or pertaining to the contract, the cause of action thereof shall be deemed to have arisen only at Bengaluru, where BHEL - SBD is situated. All legal proceedings pertaining to the above matters or dispute shall be instituted only in courts having territorial jurisdiction over the place where BHEL-SBD is situated and no other court shall have the jurisdiction.
13.	DUTIES AND RESPONSIBILITIES OF THE CONTRACTOR:
13.1.	The duties and responsibilities and obligation of the contractor including statutory responsibilities mentioned in this document are indicative and not exhaustive. Contractors are required to confirm with the concerned authorities for proper and complete compliance.
13.2.	The contractor will abide by the provisions of Child Labor (Prohibition & Regulation) Rules 1988. He should issue appropriate Appointment Letter to his Workmen.
13.3.	The following documents / forms under Contract Labor (Regulation & Abolition) Act 1970 and relevant rules therein shall be maintained by the contractor: (i) A notice showing the wage period and the place and time of disbursement of wages to be displayed at the place of work and a copy sent by the contractor to the HR Department (Rule 75). (ii) A register of workman From XIII (Rule 75) (iii) Employment card From XIV (Rule 76) (iv) Service Certificate From XV (Rule 77) (v) Muster Roll, Wage Register, Deductions Register, overtime Register, leave register etc. (vi) Half yearly return to be sent (In duplicate) by the contractor to the licensing officer. From – XXIV (Rule 82 (I) with a copy to HRM Department regularly. (vii) All statutory registers and records shall be preserved in original for a period of Ten years and should be made available even after the contract is over for verification.
13.4.	The contractor shall comply with the provisions of Contract Labor (R & A) Act including provisions relating to welfare and Health facilities as provided under the Contract Labor (R& A) Act 1970 and relevant rules.
13.5.	All the registered contractors shall submit the returns required under contract Labor (Regulation & Abolition) Act 1970 and forward a copy to HR Department of BHEL-SBD
13.6.	SBD – Bengaluru is a Notified Area under the provisions for ESI Act 1948. The contractor shall comply with the provision of ESI Act, and will be responsible for any liability arising during the tenure of the work contract under the Act, The contractor should ensure ESI coverage and facilities to his workers (i.e. ESI code no. and ESI card etc.) as per ESI Scheme from ESI authorities including Medical Benefit etc., The contractor shall arrange for filing of family declaration forms in respect of their contract labors and deposit the same in ESI office for issue of Identity card by ESI authorities. The contractor may deduct required ESI contribution from the wages of their employees as per law and deposit the same (Employees share) along with his contribution to the ESI authorities.
13.7.	Workmen insured under ESI Act only shall be deployed in contract work.
13.8.	The contractor shall submit bi-annual return in Form 6 along with monthly Challans to the appropriate authority under the provisions of Employee's State Insurance Act 1948, and send an intimation to HR Department of BHEL-SBD.
13.9.	Not with standing anything contrary to this, in the event of accident the contractor shall be required to submit injury report to the concerned authorities with a copy of the same to the designated BHEL Executive immediately and ensure the compliance of the ESI Act and rules made therein.
13.10.	The contractor shall submit the following returns to the appropriate authority under the provisions of Employee's Provident Fund and Misc. Provisions Act 1952, Employees' Pension Scheme 1995 under intimation to HR Dept. (i) Monthly return in Form 12 A along with form 5 & 10 (addition and deletion) and monthly Challan. (ii) Annual Return in Form 6A along with Form 3A.



13.11.	<p>The Contractor shall maintain the following records as required under the Employees Provident Fund and Miscellaneous Provisions Act 1952, Employee's Pension Scheme 1995</p> <ul style="list-style-type: none">▪ Declaration of Nomination, Form No.2 Para 33 and 61 (1).▪ Pass Book.▪ Cash Book.▪ Attendance.▪ Wage Register.
13.12.	<p>The contractor shall regularly pay the amount of contribution (employer's contribution as well as the employee's contribution) as per the Employee's Provident Fund and Miscellaneous Provisions Act 1952, Employees' Pension Scheme 1995 and Employee's State Insurance Act 1948.</p> <p>(i) The contractor may recover from his workmen, the employee's contribution in accordance with the provision of the said act and the Scheme but shall not recover the employer's contribution or the other charges from his employees in any manner.</p> <p>(ii) The contractor shall submit along with monthly bills to BHEL, statement showing the recoveries of contributions in respect of employees employed by or through him along with the proof of Deposit of such contribution with the Concerned Authority and shall also furnish to BHEL such information, in the capacity of principal Employer, as required to furnish under the provisions of the schemes under the Employees P.F. and Misc. Provisions Act 1952 and ESI Act, 1948 to the authorities under the said acts.</p> <p>(iii) The Contractor shall arrange for his own P.F. and ESI Code No. from the PF and ESI authorities respectively. The contractor will be reimbursed by BHEL the expenditure incurred by the contractor towards payment of the Employers Contribution and PF Administrative charges.</p>
13.13.	<p>Any failure to comply with the statutory requirements on the part of contractor shall disqualify such contractor from all contracts awarded to him and his name shall be black listed for further tenders / contracts. In addition, the contractor's security deposit shall be forfeited apart from consequential legal action against him.</p>
13.14.	<p>The contractor shall maintain Form D as per Rule 5 of the Payment of Bonus Act, 1965. The contractor is further liable to pay bonus to his employees in accordance with the payment of Bonus Act 1965 and to keep all the records in Form C as per the said Act.</p>
13.15.	<p>In case the contractor employs women, he will discharge his obligation under law in respect of such women workers such as prohibition of engaging them during night hours, prohibition of employing them more than 9 hours per day, provision of crèche facility, grant of maternity leave as per rules etc.</p>
13.16.	<p>The Wage period for the Workmen of Contractors shall be Calendar Month and the contractor shall be responsible for making payment of wages within 7 days of the closure of the wage month. The disbursement shall be preponed to the 6th day, if the 7th day happens to be a holiday. Similarly, in case of Overtime wages, the contractor shall make the OT payment to his workmen along with the salary within 7 days of the closure of the wage month The Contractor would be required to open an Account for Electronic Fund Transfer (EFT) of his Bills/Claims from BHEL as well as EFT of wages/OT/other payments of his workmen from his Account to the Accounts of his workmen so that risks associated with cash transactions can be avoided.</p>
13.17.	<p>The Contractor shall be required to issue monthly Wage /OT Slips to their workmen. Further, the Contractors claims are to be accompanied by a Certificate from BHEL Official certifying that "the Wage /OT Slips for the previous month/current month have been issued by the contractor to all their workmen". Further, the contractor would be required to issue Annual PF Statement from the PF Authorities for all his workmen engaged in BHEL Malleswaram Complex before submitting Claim for refund of Security Deposit for the respective years.</p>
13.18.	<p>In case contractor fails to make payment of wages to his employees or remittance of contribution to the concerned authorities, the Security deposit / other dues payable under the contract can be utilized by BHEL to discharge the liability of the contractor.</p>
13.19.	<p>The workmen of the contractors shall wear uniform while attending duty in BHEL campus which must be different in color from the color of uniform of regular employees. The Contractor/his authorized representative shall ensure wearing of the Uniform and Safety Shoe by his workmen in the BHEL premises. The name of the contractor for</p>



	which the worker is working should be made available on the uniform. The cost of the uniform and Safety Shoe will be borne by contractor. The contractor should ensure and provide masks and gloves to the workmen engaged by him in view of the pandemic COVID-19, till such time it exists. The cost of the same will be borne by contractor.
13.20.	The liability for compensation on account of injury sustained by an employee of the contractor will be exclusively that of the contractor.
13.21.	NATIONAL & FESTIVAL HOLIDAYS (as declared by BHEL): The contractor will give paid National Holidays and Festival Holidays to the workers as per Section 5 of National and Festival Holidays Act. However, if due to the exigency of work if any of his workmen is required to work on National Holiday or Festival Holiday, the contractor has to pay wages as per Section 5, sub section 2 and 3 of the said Act.
13.22.	Besides the three national holidays 15 th February, 26 th January and 2 nd October, if Govt. declares any other day as a national holiday same will be treated as paid holiday for the purpose of this contract. Accordingly, the contractor shall be required to provide paid holiday to its workers for the same. If any of the contract workmen works on such additional declared national holiday, he will be entitled to additional wage for the said day.
13.23.	GENERAL ELECTIONS: If the general elections are held for State Assembly / Parliament and Government declares a public holiday for exercising the franchise, the contractor shall give their workmen half day leave in "First" shift only. The contractor's workmen working in "Second" and "Night" shifts will be required to exercise their franchise during their own time.
13.24.	The Contractor shall maintain the following Documents, Registers, Forms as required under the FACTORIES Act 1948 and Rules 1969. (I) Leave Book Form No. 15 (Rule 121) (II) Nomination Form No. 25 (Rule 127)
13.25.	The contractor will extend leave with wage to his workers who have worked for a period of 240 days or more during a calendar year. To facilitate the proper execution of the Factories Act, these leaves shall be allowed during the same calendar year, at the rate of one day for every 20 working days. A worker commencing service on a day other than the 1st day of the January shall be entitled to leave with wages at the above rate (one day for every 20 days of work) only if he has worked for 2/3 of total no. of days in the remaining year. The contractor will pay the un-availed portion of leave in cash every Six month from the start of the contract.
13.26.	Contractor has to ensure that all his workmen are granted one day weekly off after every 48 hrs. of working. The workmen working for more than 48 hours in any week shall be paid wages twice the ordinary rate of wage in accordance with the provisions of Section 59 of the Factories Act, 1948 read with the Karnataka Factories Rules.
13.27.	The contractor shall follow safety rules and regulations as per provisions of Factories Act 1948, and Rules at his own expense and arrange for the safety provisions as appended to these conditions or rules framed by the government from time to time.
13.28.	Refund of Security Deposit: Security Deposit of contractor will be refunded only after the expiry of the contract period and based on the certification of successful completion of the contract by the concerned Officials and submission of an Indemnity Bond from the contractor, that in case of Claims from any of the statutory authorities, the same would be indemnified by the Contractor. In case of completion of the contract before payment of bonus to the workers, Security Deposit, as deemed appropriate, will be withheld by BHEL. The same would be released to the Contractor after submission of proof of bonus payment to his workmen.
13.29.	The Contractor shall be required to deposit Tax as applicable, if same is applicable as per rules in force from time to time. The amount so spent can be claimed from BHEL after submitting the proof of the same. The contractor has to obtain GST registration wherever required. The Contractor must quote the Service Account Code (SAC) number at the time of raising invoice.
13.30.	Contractor shall inform his PAN to BHEL. Income tax as applicable will be deducted at source by BHEL from the bill of contractor.



13.31.	All the Registers and Records, forms, Notices maintained under the relevant Acts and Rules should be produced on demand before the Inspector or any other authority under the Act, failing which the contract may be terminated without any notice.
13.32.	Contractor shall be required to submit a list of his workers to be deployed for the works contract giving details regarding Name of contract worker, Fathers Name, permanent and Present Address, Date of Birth, Qualification, Caste-SC/ST/OBC, ESI No, PF No. and the family details.
13.33.	The contractor shall abide by all the labor legislations and other laws including the provisions of Contract Labor (Regulation & Abolition) Act, 1970, the Factories Act, 1948, the Payment of Wages Act, 1936, the Minimum Wages Act, 1948, ESI Act, Employee Provident Fund Act and other relevant Acts applicable to his workmen under this Contract.
13.34.	BHEL shall be indemnified against all losses, Claims, prosecutions etc. under any law.
13.35.	The contractor shall promptly furnish all information and document required by BHEL authorities for the purpose of complying with the responsibilities of Occupier of the factory and shall render all the necessary assistance for the same.
13.36.	The contractor will maintain proper discipline of his workmen and will ensure that his workers do not cause any loss or theft or damage to any company's property. The contractor will also be responsible for the good conduct of his workmen.
13.37.	The contractor shall ensure and maintain uninterrupted progress of the work in accordance with instructions given to him on behalf of BHEL from time to time.
13.38.	In case the contractor makes default in commencing the work within the time specified by BHEL without any reasonable cause, disputes any of the terms and conditions of the contract or refuses to execute the contract or any part thereof at any stage, the contract shall, without prejudice to any other right or remedies available to BHEL, be liable to be cancelled / terminated in part or in whole. In the event of such cancellation / termination of contract, the contractor shall be liable; to compensate BHEL for all losses incurred by BHEL including the loss suffered on account of having the work executed through any other contractor or department as may be convenient to BHEL, in accordance with the exigencies of the work. In case only a part of the contract is cancelled, the remaining portion of contract may be allowed be executed by the contractor.
13.39.	The Contractor, shall, without fail, give up-to-date information in writing of the attendance of the workers engaged by him. The Contractor will also submit the required documents and certificates as prescribed from time to time for the clearance and the payment of the Bill.
13.40.	Whenever any sum of money is found to be recoverable from or payable by the contractor, the same will be deducted from any sum that may due or which at any time there after becomes due to the contractor under this contract or under any other contract or from his security deposit. In case the recoveries are not complete even after such deduction, the contractor shall pay the same or the balance thereof from the security deposit. The contractor shall immediately thereafter pay such further sums as may be required to replenish the shortage caused by such recoveries in the amount of security deposit.
13.41.	During the currency of contract, if the contractor is awarded any other work contract in BHEL, the contractor will have to inform the designated BHEL official before accepting the other work.
13.42.	In case of failure on the part of the contractor to execute the work awarded to him within the stipulated time, the sum equivalent to the EMD as per BHEL Works Policy shall be forfeited as per the Undertaking provided by tenderers, after a week's notice issued by the awarding officer and BHEL may in its discretion award the contract to any other party.
13.43.	In case of any extra work executed by the contractor, the contractor will be paid on pro-rata basis
13.44.	All the Terms and Conditions as mentioned in Work Order will also form a part of the Agreement.



13.45.	BHEL shall have the right to deduct any sum from the bill of the contractor for making good the loss suffered by a worker or workers by reason of non-fulfillment of the conditions of the contract, Non- payment of wages or of deduction made from his or their wages which are not justified by the terms of the contract or non-observance of the said contract Labor regulations.
13.46.	The contractor shall be responsible for observance of local laws, employment of personnel, payment of taxes etc. As far as possible, workers shall be engaged from the local areas in which the work is being executed.
13.47.	The contractor shall be wholly responsible for the behavior of the workmen at the work place and outside, in the BHEL premises.
13.48.	The contractor shall be responsible for safe custody of BHEL's property like materials, tools etc., entrusted to him and if necessary arrange insurance at his own expense.
13.49.	The contractor shall be responsible to make good and rectify at his own expense any defect, which may develop or may be noticed within the period of the contract.
13.50.	BHEL shall be entitled to recover any payment made on behalf of the contractor under any law or otherwise.
13.51.	BHEL Officer In-charge shall have the right to stop the work at any stage or at any time by giving the contractor seven days' notice in writing.
13.52.	CARTEL FORMATION: The Bidder declares that they will not enter into any illegal or undisclosed agreement or understanding, whether Formal or informal with other Bidder(s). This applies in particular to prices, specifications, certifications, subsidiary contracts, submission or non-submission of bids or any other actions to restrict competitiveness or to introduce cartelization in the bidding process. In case, the Bidder is found having indulged in above activities, suitable action shall be taken by BHEL as per Extant policies/ guidelines.
14.	ARBITRATION & CONCILIATION:
14.1.	Except as provided elsewhere in this Contract, in case amicable settlement is not reached between the Parties, in respect of any dispute or difference; arising out of the formation, breach, termination, validity or execution of the Contract; or, the respective rights and liabilities of the Parties; or, in relation to interpretation of any provision of the Contract; or, in any manner touching upon the Contract, then, either Party may, by a notice in writing to the other Party refer such dispute or difference to the sole arbitration of an arbitrator appointed by Head of the BHEL Electric & Photovoltaic Division.
14.2.	The Arbitrator shall pass a reasoned award and the award of the Arbitrator shall be final and binding upon the Parties
14.3.	Subject as aforesaid, the provisions of Arbitration and Conciliation Act 1996 (India) or statutory modifications or re-enactments thereof and the rules made thereunder and for the time being in force shall apply to the arbitration proceedings under this clause. The seat of arbitration shall be Bengaluru.
14.4.	The cost of arbitration shall be borne as per the award of the Arbitrator.
14.5.	Subject to the arbitration in terms of 11.3, the Courts at Bengaluru shall have exclusive jurisdiction over any matter arising out of or in connection with this Contract.
14.6.	Notwithstanding the existence or any dispute or differences and/or reference for the arbitration, the Contractor shall proceed with and continue without hindrance the performance of its obligations under this Contract with due diligence and expedition in a professional manner except where the Contract has been terminated by either Party in terms of this Contract.
15.	COMPENSATION:
15.1.	"BHEL shall recover the amount of compensation paid to victim(s) by BHEL towards loss of life / permanent disability due to an accident which is attributable to the negligence of contractor, agency or firm or any of its employees as detailed below.



	<p>a) Victim: Any person who suffers permanent disablement or dies in an accident as defined below.</p> <p>b) Accident: Any death or permanent disability resulting solely and directly from any unintended and unforeseen injurious occurrence caused during the manufacturing/ operation and works incidental thereto at BHEL factories/ offices and precincts thereof, project execution, erection and commissioning, services, repairs and maintenance, trouble shooting, serving, overhaul, renovation and retrofitting, trial operation, performance guarantee testing undertaken by the company or during any works / during working at BHEL Units/ Offices/ townships and premises/ Project Sites.</p> <p>c) Compensation in respect of each of the victims:</p> <p>(i) In the event of death or permanent disability resulting from Loss of both limbs: ₹10,00,000/- (Rupees Ten Lakhs)</p> <p>(ii) In the event of other permanent disability: ₹7,00,000/- (Rupees Seven Lakhs)</p> <p>d) Permanent Disablement: A disablement that is classified as a permanent total disablement under the proviso to Section 2 (I) of the Employee's Compensation Act, 1923."</p>
16.	REVERSE AUCTION TERMS & CONDITIONS
16.1.	LOG IN NAME & PASSWORD: Each Bidder is assigned a Unique User Name & Password by Service Provider. Bidders are requested to change the Password and edit the information in the Registration Page after the receipt of initial Password from Service Provider All bids made from the Login ID given to the bidder will be deemed to have been made by the bidder.
16.2.	BIDS PLACED BY BIDDER: The bid of the bidder will be taken to be an offer to sell. Bids once made by the bidder cannot be cancelled. The bidder is bound to sell the material as mentioned above at the price that they bid. Should any bidder back out and not make the supplies as per the rates quoted, BHEL and / or Service Provider shall take action as appropriate.
16.3.	Auction Start price & decremented Value: The Start Price shall be lower of estimate or L1 of sealed envelope price bid & Decrement value applicable in the on line reverse auction will be decided by BHEL after evaluating the bids received from the vendors in the sealed envelope price bid and will be available to the vendors on the bidding screen of the online reverse auction.
16.4.	LOWEST BID OF A BIDDER: In case the bidder submits more than one bid, the lowest bid will be considered as the bidder's final offer to sell. The bidders to note that the first appreciable bid that comes in the system must be equal to or less than the auction start price which the bidder can view at the start of reverse auction and subsequent bids shall conform to minimum decremented value or multiples of the decremented value.
16.5.	AUCTION TYPE: English No Ties Reverse (Refer Bidder Manual)
16.6.	VISIBILITY TO BIDDER: The Bidder shall be able to view the following on his screen along with the necessary fields: <ul style="list-style-type: none">• Rank of the bidder• Lowest bid in the reverse auction• Bid Placed by him
16.7.	AUCTION WINNER: At the end of the Reverse Auction, BHEL will evaluate all the bids submitted and will decide upon the winner.
16.8.	GENERAL TERMS & CONDITIONS: Bidders are required to read the "Terms and Conditions" section of the auctions site ----- using the Login ID and passwords given to them.
16.9.	The Supplier / Bidder shall not involve himself or any of his representatives in Price manipulation of any kind directly or indirectly by communicating with other suppliers / bidders.
16.10.	The Bidder shall not divulge either his Bids or any other exclusive details of BHEL to any other party.
16.11.	BHEL's decision on award of Contract shall be final and binding on all the Bidders.
16.12.	BHEL along with Service Provider can decide to extend, reschedule or cancel any Auction. Any changes made by BHEL and / or Service Provider after the first posting will have to be accepted if the Bidder continues to access the site after that time.



16.13.	BHEL/Service Provider shall not have any liability to Bidders for any interruption or delay in access to the site for the reasons which include Power supply interruption, System failure, non-availability of WEB/Screen etc.
16.14.	BHEL/Service Provider is not responsible for any damages, including damages that result from, but are not limited to negligence. BHEL / Service Provider will not be held responsible for consequential damages, including but not limited to systems problems, inability to use the system, loss of electronic information etc.
16.15.	All the Bidders are required to submit the Agreement Form duly signed to Service Provider. After the receipt of the Agreement Form, Log in ID & Password shall be allotted to the suppliers (bidders).
16.16.	After the completion of the Auction event, all the Bidders have to submit the Price Breakup immediately to Service Provider for further proceedings.
17.	PENALTY/ LD FOR DELAYED DELIVERY: BHEL RESERVES THE RIGHT TO RECOVER FROM THE CONTRACTOR, AS AGREED LIQUIDATED DAMAGES AND NOT BY WAY OF PENALTY, A SUM EQUIVALENT TO HALF (½) PERCENT OF THE TOTAL CONTRACT PRICE PER WEEK OR PART THEREOF, SUBJECT TO A MAXIMUM OF TEN (10) PERCENT OF THE TOTAL CONTRACT PRICE EXCLUDING ELEMENTS OF TAXES, IF THE CONTRACTOR FAILS TO DELIVER THE REQUIRED SERVICES WITHIN THE STIPULATED CONTRACT TIME / PERIOD.
18.	CONCILIATION CLAUSE – Annexure IA
19.	MAKE IN INDIA CLAUSE
19.1.	i. For this procurement, Public Procurement (Preference to MAKE IN INDIA) Order 2017 Dated 15.06.2017, 28.05.2018, 29.05.2019, 04.06.2020 and subsequent orders issued by the respective Nodal Ministry shall be applicable. Even if issued after issue of this NIT but before finalization of contract WO against this NIT. ii. In the event of any Nodal Ministry prescribing higher or lower percentage of purchase preference and/ or local content in respect of this procurement same shall be applicable.
20.	FORMATS
20.1.	Reverse Auction Forms
20.2.	Agreement Format between BHEL & Contractor
20.3.	Third Party Non-Disclosure Agreement (NDA) format
20.4.	EFT Format

Note:-

1. Part-I&II to be submitted as per instruction on <https://eprocurebhel.co.in> & www.bhel.com .

Tender Ref No. 191184

Part-A



2. Earnest Money Deposit shall be submitted as per NIT page No. 4 of this tender document.
3. Tenders will be liable for rejection if the above mentioned EMD is not submitted along with the tender.
4. ~~Only those bidders who have entered into Integrity Pact with BHEL would be competent to participate in the bidding. In other words, entering into integrity Pact shall be preliminary qualification. Details of Independent External Monitors (IEM) for this tender is in page No. 1, Sl. No. 11.~~
5. In view of present pandemic situation, it is advised to all bidders to mandatorily ensure all precautionary measures as per guidelines issued by State/Central government/District administration to prevent spread of COVID-19 like usage of Personal Protective Equipment's and other norms like wearing masks, maintaining social distance and other instructions issued from time to time.
6. Firms banned by BHEL are not eligible to participate in the tender. The tender submitted by such a firms will not be opened for evaluation and no communication in this regard will be entertained.
7. Bidders under Notice period/issued show clause notice is not qualified to participate in the tender
8. Please ensure submission of offer before the due date and time on <https://eprocurebhel.co.in> only. No other mode of submission is permitted. Late offers will be rejected.
9. Bidders are advised to quote their best prices (% above/below the total estimate +/- (or) at par) as no further price bids will be accepted in case BHEL decides to open price bids instead of reverse auction. The rate/ Percentage quoted by the bidder shall be including all taxes but excluding GST which shall be shown separately in price bid.
10. Site progress will be reviewed periodically from the date of issue of work order and based upon the progress of work by contractor if contractor is unable to meet the target after repetitive notices/warnings, BHEL reserves the right to get any part of the work done through other agency or deploy BHEL's own/hired/otherwise arranged resources, at the risk and cost of the contractor after due notice of a period of one week.
11. Bidder agrees to submit performance security required for execution of the contract within the time period mentioned. In case of delay in submission of performance security, enhanced performance security which would include interest (SB/ rate + 6%) for the delayed period, shall be submitted by the bidder. Further, if performance security is not submitted till such time the first bill becomes due, the amount of performance security due shall be recovered as per terms defined in NIT , from the bills along with due interest.
12. The Bidder declares that they will not enter into any illegal or undisclosed agreement or understanding, whether formal or informal with other Bidder(s). This applies in particular to prices, specifications, certifications, and subsidiary contracts, submission or non-submission of bids or any other actions to restrict competitiveness or to introduce cartelization in the bidding process. In case, the Bidder is found having indulged in above activities, suitable action shall be taken by BHEL as per extant policies/ guidelines.
13. Start-ups registered with DIPP are exempted to fulfill the criteria of minimum turnover and minimum years of experience.
14. In view of the necessity to complete the works as per the schedule and for stringent quality control it is required that works awarded to contractor shall not be sublet by the contractor to any other agency in partial or full, without prior approval of BHEL. All works shall be carried out under the supervision of contractor by placing their regular employees at site.

Documents required to be submitted

1. Registration Certificate with ESI and PF Authority/Declaration.
2. Income Tax Returns for last Three years
3. Balance Sheet and Profit & Loss Account for the last 03 years certified by auditor.
4. Availability of Technical personnel in letter head.
5. Registration with BHEL/CPWD/other Govt. organization/PSU if any.
6. Declaration for full filling the BOCW requirements.
7. List of equipment to be mobilized at site.

Tender Ref No. 191184

Part-A



8. GST Registration details or Declaration.

9. Declaration/Certificate of MSE/Qualify for PPP MII order 2017 (Udhyam).

All the supporting documents to be signed and sealed by the bidder (BHEL have the rights to verify the original documents if required)

INFORMATION TO THE TENDERER:

- (i) Successful Bidder should establish their Site office at Construction site, including common facilities such as toilet, water, electricity etc. in consultation with BHEL. Contractor has to arrange water and power as required for completing the job in the stipulated time frame at their own cost.
- (ii) Contractors shall take at most care on their manpower deployed, considering the current outbreak due to COVID-19, contractor shall take all precautionary measures and follow guideline issued by state and central government to contain and spreading of CORONA VIRUS.
- (iii) Contractor shall issue face mask and gloves to the labours and maintain social distancing while carrying out the work. WEARING OF FACE MASK AND GLOVES IS MANDATORY AT THE WORK PLACE.
- (iv) The bidders should furnish "Site Inspection Certificate" in Annexure-III enclosed herewith.
- (v) Bidders should study the prevailing Market trend of Construction materials/laborers/other relevant requirement before quote and submit the competitive price.
- (vi) The bidder should encourage to use local labor that has the necessary skills as per the requirement of work.
- (vii) Before engaging the labour in to work, Contractor should get the NOC from labours' native police station as well as NOC from local police station (If applicable).
- (viii) The bidders should carry out preliminary survey at proposed construction site before submission of offer to ensure that the rate quoted for the relevant schedule of items are correct.
- (ix) Contractor to note BHEL reserves the right to get any part of the work done through other agency or deploy BHEL's own/hired/otherwise arranged resources, at the risk and cost of the contractor after due notice of a period of two weeks by BHEL, in the event of:-
 - a) Contractors continued poor progress
 - b) Withdrawal from or abandonment of the work before completion of the work.
 - c) Contractor's inability to progress the work for completion as stipulated in the contract
 - d) Poor quality of work
 - e) Corrupt act of Contractor
 - f) Insolvency of the contractor
 - g) Persistent disregard to the instructions of BHEL
 - h) Assignment, transfer, sub-letting of contract without BHEL's written permission
 - i) Non fulfillment of any contractual obligations
 - j) In the opinion of BHEL, the contractor is overloaded and is not in a position to execute job as per required schedule.
- (x) The liquidated damages (LD)/penalties arising out of Risk and Cost as explained under Sl.no (ix). BHEL shall recover the amount from any money due from Contractor, or from any money due to the contractor including security deposit, or by forfeiting any T & P or material of the contractor under this contract or any other contract of BHEL or by any other means or any combination thereof.

(xi) Documents to be submitted on award of work (as applicable):

- a) Security deposit in the form of Cash/DD/ NSC's / Kisan Vikas Patra / FDR /NEFT/RTGS/Bank Guarantee in favor of BHEL

Tender Ref No. 191184

Part-A



- (b) Electronic Fund Transfer Form duly signed & sealed by banker along with cancelled cheque copy
- (c) Labour license of the workmen engaged valid for contract period (If applicable)
- (d) Workmen Compensation Insurance Policy for the workmen engaged valid for contract period (as applicable)
- (e) Deduction of statutory taxes (as applicable) at source would be enforced from the running bills at the rates prescribed unless exemption certificate is produced from the concerned authorities.

The following documents are to be submitted along with the Running Account Bills for process of payment

- a) Tax Invoice with details of GST number of BHEL and contractor.
- b) Measurement books duly filled and signed by officials of BHEL and contractor
- c) Provident PF Remittance challan for the bill duration.
- d) ESI Remittance challan for the bill duration.
- e) Invoice submitted along with running bills to indicate the GST amount charged and bear GST NUMBER etc. as per prevailing taxes. Bill submitted subsequently to be accompanied with a declaration that GST liability on the earlier bill has been discharged.
- f) by paying money to the Government (along with Tax paid Challan Copy)
- g) by utilization of Input GST Credit
- h) BOCW Registration and payment proof.
- i) Field quality assurance documents (as applicable) as per instruction of Engineer In-charge.
- j) List of supplier/supplier's (material and manpower).
- k) After completion of work, bidders should mandatorily furnish NOC from all declared suppliers along with the running /Final Bill.

Mobilization at site:

- 1) Requisite Material (all construction materials like cement, sand, coarse aggregate, reinforcement steel, etc.), men (mason, carpenter, bar binder, fabricator, etc.) and machinery (DTH, Concrete mixer machine/RMC/AJAX with printing facility, Power chain saw, JCB/excavator/dozer, grader, tipper, etc., Total station & other equipment required for building works and levelling, grading works, and other associated works as listed in BOQ) should be arranged in order to complete the project within stipulated time period.
- 2) The contractor shall carry the work as per the approved Field Quality Plan issued by BHEL (Field quality plan enclosed with this tender for reference)
- 3) Calibration of equipment's should be done by NABL accredited laboratories.
- 4) Contractor shall submit the design mix report (from NABL/Govt. approved labs) and shall carry the work as per the approved design mix report, approved by BHEL.
- 5) Contractor shall conduct the pile load test (Initial and routine test) (OR) any test (as applicable) and shall submit the report (from NABL/Govt. approved labs) as approved by BHEL.
4. Tenders should be addressed to: Mr.B.M.Hiremani., AGM (Bharat Heavy Electricals Limited- Solar Business Division, Professor C.N.Rao Circle Opposite Indian Institute of Science Malleshwaram, Bangalore– 560 012. **Tenders should be submitted on <https://eprocurebhel.co.in>**. In two part bid. Part-1 "Technical cum Commercial Bid" and Part-2 Price Bid. DD for Tender document Cost (if applicable) & EMD duly submitted along with the tender documents (Original DD/BG for EMD to be sent to address of dealing Officer, BHEL-SBD Bangalore detail as per NIT-page 4).
5. The local address of the Contractors, the name of the person to whom all the Correspondence are to be addressed should be indicated, with telephone number (both office and residence).
6. All entries in tender documents should be in one ink (preferably blue ink). Erasing and overwriting is not permitted. All corrections should be duly signed by tenderer concerned.



7. Tenderers shall fill in all the required particular in the blank space provided for this purpose in the tender documents and also sign in each and every page of the tender document including the drawings attached there to before submitting tender.
8. Unit rate/percentage above or below estimate should be quoted in figures as well as in words in Indian Currency only i.e. Rupees and Paisa with reference to each item and for the items shown in the attached schedule. These rates shall be for the finished work at site. The rate shall include all taxes and duties payable on account of Octroi, Sales Tax, tax on work contract etc., (as applicable) and also expenses towards PF and ESI contributions (see clauses 8, 40 and Enclosure 'C') but excluding GST.
9. In case the rate quoted in figures differs from those quoted in words, the lower of the rates quoted will be taken as the tendered rate and shall be binding on the tenderer.
10. The rate to be quoted by the tenderer shall be firm and shall cover and include all statutory levies such as "BOCW, Octroi, sales tax, excise duty etc., arising from Act passed by Parliament or State Legislature and rules framed there under. The rates shall further be deemed to include statutory levies arising from such Acts, Central or State, which may come into force, subsequent to submission of tenders.
11. (a) The rate quoted in the tender shall remain valid for a period of 'THREE MONTHS' from the date of opening tender.
- (b) Tenderer shall not increase quoted rates, once the tenderer has submitted offers/quotation/price and during execution of contract in case tender is accepted.
- (c) Successful bidder should execute the work strictly in accordance with Tender schedule quoted rates as accepted by BHEL.
- (d) PRICE VARIATION clause not applicable.
12. The rates quoted should be inclusive of all taxes arising on the transaction. If BHEL is required to discharge the liability of any taxes on the transaction like TDS(IT), TDS(WCT), TDS(GST) (as applicable) under reverse charge mechanism or any other similar taxes, which is or becomes payable by BHEL, the same shall be deducted from the bills of the contractor. The rate/Percentage quoted by bidder shall be including all taxes but excluding GST which shall be shown separately in price bid.
13. Quantities shown in the schedule are only approximate and are liable to variation without entitling the Contractors to any compensation.
14. Before tendering, the tenderer are advised to inspect the site of work and its environments and be well acquainted with the actual working and other prevailing conditions, position of material and labour. They should be well versed with BHEL General Conditions of Contract instruction to the tenderers, drawing and specification and all other documents which form part of the agreement to be entered into subsequent to award of work. The tenderer should be specially note that it is tenderers responsibility to provide any items which is not specifically mentioned in the specifications and drawing, but which is necessary to complete the work.
15. Details and quantities of each item of work shown in the bill of quantities attached here to only approximate. They are given as a guide for the purpose of tendering only and are liable for variation and alteration at the discretion of the competent authority. The work under each item as executed shall be measured and price at the corresponding rates to be quoted by the Contractor in the bill of quantities attached hereto.
16. Should a tenderer find discrepancies or omission in the drawing attached to the tender documents or should be in doubt as to their meaning he should at once address to the authority inviting the tender for clarifications. Every endeavor is made to avoid any error which can materially affect the basis of the tender but successful tenderer shall take upon himself to provide for the risk of any error which may be subsequently discovered and shall make no subsequent claim on account thereof.
17. In the event of the tender being submitted by a firm the tender must be signed separately and legibly by each partner or member of the firm or in their absence, by the person holding the power of Attorney on behalf of firm



concerned. In the latter case, a copy of the power of Attorney duly attested by a Gazette Officer must accompany the tender.

18. If in any case, the date of Tender Opening falls on holiday, the Tender will be opened on the next working day.

19. Every tender must be accompanied by Earnest Money Deposit. This earnest money will be refunded to the unsuccessful tenderer after finalization of the award of work. In the case of successful tenderer, the earnest money will be retained as a part of Security Deposit for satisfactory completion of the work in accordance with Clause-16 of BHEL General Conditions of the Contract. Tenders without Earnest Money Deposit receipt are liable to reject. No interest will be paid on the earnest money deposit.

20. The Earnest money deposit may be furnished

a) Demand Draft in favor of BHEL SBD, Bangalore – 560012.

b) The Earnest money deposit may be furnished through online

c) Bank guarantee as per Sl. No. NIT page No. 1. As applicable

21. For reimbursement of Earnest Money Deposit, the tenderer should fill the enclosed EFT form, obtain the Banker's signature and also enclose a photocopy of cancelled cheque leaf.

22. EMD may be submitted in Bank guarantee as per Sl. No. 4 (b), page No. 1, in BHEL format in Non judicial stamp paper amounting Rs.200 (or) applicable rate at bidder's state, whichever is higher. Bank guarantee from any Co-operative banks are not acceptable in any circumstances.

23. Unless the bidder whose tender is accepted signs contract agreement (If applicable) within fifteen days (15 days) of the date of the order directing to do so, the amount of Earnest Money already deposited by bidder will be forfeited and acceptance of the tender withdrawn as per discretion of BHEL.

24. If after opening of tenders a tenderer revokes the tender or increase of earlier quoted rates or after acceptance of his tender does not commence the work in accordance with the instruction of Engineer-in-charge, the Earnest Money Deposited by bidder will be forfeited and acceptance of bidder's tender withdrawn. If only a part of work included in the tender had been awarded to the tenderer, the amount of Earnest Money to be retained will be based on value of the contract so awarded.

25. The BHARAT HEAVY ELECTRICALS LIMITED reserve the right to reject any or all the tenders received or accept any tender or part thereof without assigning reason thereof. In the case of acceptance of a part of tender, the time for completion may also be reduced to the extent considered necessary by the accepting authority.

26. Conditional and Unsigned tenders, tenders which are incomplete or otherwise considered defective, tenders which are not in accordance with the tender conditions laid down by the accepting officer and tenders not submitted in the prescribed forms are liable to be rejected.

27. Tenderer shall submit Solvency Certificate for the value specified from a Bank of standing regarding the tenderer's financial position (as applicable).

28. The tenderers should enclose relevant documents regarding constitution of firm i.e. Individual / Sole Proprietorship Concern / Partnership Firm / Public Limited Company / Private Limited.

29. The tenders should be enclosed with a list of contracts already held by the tenderer at the time of submitting the tender and giving the following particulars:

a) Name of the work, value and address.

b) The balance work remaining to be done on the same.

30. The Contractors responsibility under this contract shall commence from date of receipt of the order or acceptance of tender.

31. ~~Tenders submitted by speed post or courier service shall be posted with due consideration of any delay in postal delivery. Tenders received after the due date of opening tenders are liable to be rejected.~~

32. If proprietor or partner of a firm expires after the submission of tender or after the acceptance of tender, BHEL reserves the right to cancel the contract if the character of the firm undergoes a substantial change.



33. THE BHARAT HEAVY ELECTRICALS LIMITED will not be bound by any power of Attorney granted by the tenderer or changes in the composition of firm made subsequent to signing of the contract. They may however recognize such power of Attorney and changes after obtaining proper legal advice.
34. If the tenderer deliberately gives wrong information on tender regarding past unsatisfactory performance with BHEL sister units, BHEL reserves the right to reject such tender at any stage including contract execution period.
35. Words imparting the singular number shall also be deemed to include the plural number and vice versa where the context so require.
36. The General and Special Conditions are complementary to each other and where they are in conflict, the special condition shall prevail.
37. The expenses for completing the stamping agreement shall be paid by the contractor.
38. Unless or otherwise stated above tendered work includes men, material, machine and commissioning of equipment as agreed to in the contract.
39. After completing of the job, the contractor has to furnish actual drawings of work done in consultation with Engineer-in-charge.
40. Any covering letter and comments of the tenderer should be submitted along with the offer.
41. Cement and steel for carrying out Civil Works will have to be procured by the Contractor. Materials shall be accompanied with Test certificates and connected dispatch documents for proof of source from approved manufacturer's works or stockyard. The Contractor shall provide all the materials needed for trial run, testing including chemicals, consumables etc. In quoting their rates, the Contractors are advised to take into account the cost of the above materials. All the construction materials should be approved by BHEL before commencement of work.
42. Contractor are required to follow Field Quality Plan (FQP) for Civil construction as approved by BHEL/customer in respect of Tests to be carried out and reports and documents to be furnished. As applicable.
43. Should a tenderer or a contractor has a relative or in the case of firm or company, any of its shareholders relative is employed in Bharat Heavy Electricals Limited, the authority inviting tenders shall be informed of this fact at the time of submission of the tender, failing which tender may be disqualified or if such fact subsequently comes to light.
44. These 'INSTRUCTIONS TO TENDERER' & GENERAL CONDITIONS OF CONTRACT OF BHEL' shall be deemed to form an integral part of the Contract agreement for the work to be entered into. The Contractor has to scrutinize the same, and when submitting his tender, indicate his acceptance of both. In cases of variation between the two in any matter, the conditions in the 'THE INSTRUCTIONS TO TENDERER' shall prevail. (Extracts of important clauses of BHEL GCC are enclosed).
45. All operations to be carried out by the Contractor during the execution of the contract such as drilling, welding etc., shall be done with proper equipment to be brought by the tenderer. Contractor shall make his own power and water supply.
46. The Contractor shall comply with the provision of Employees Provident Fund's and miscellaneous Provisions Act 1952 and rules, regulations and other orders issued there under. He as an employer shall be liable to pay employer's contribution/deductions towards PF under the PF Act in respect of all labour employed by him for the execution of the contract in accordance with the provisions of the Employees' Provident Funds and Miscellaneous Provisions Act, 1952 as amended from time to time. For this purpose he shall indicate the code number obtained from the Regional Provident Fund Commissioner or he should obtain a code number if he has not and produce the Photostat copy of the challan receipt of monthly remittance of the contribution made by him to the Commissioner. He shall also furnish such returns such returns as are due, under the Act, to be sent to the appropriate authorities through the Principal Employer".
47. The Contractor should get himself registered with the E.S.I Authorities as an independent Employer, obtain a separate code number and remit the dues in respect of the Labour employed by him for the work and produce the challan/Receipts of remittance of the ESI contributions due under the E.S.I Act to the Company authorities. He shall also furnish such returns, as are due, under the Act, to be sent to the appropriate authorities' through the Principal



Employer. The contractor can remit their ESI & PF through a sub-agent who processes the ESI & PF code and agrees to enter an MOU with the contractor.

48. If any action is brought in by P.F. Commissioner/ESI authorities on BHEL for the work done by the Contractor for his labourers regarding PF/ESI amount due, short remittances, non-remittances etc., the Contractor shall defend the case on behalf of BHEL and / or reimburse BHEL the expenses so incurred.

49. The Contractor shall apply and obtain license under Contract labour (R&A) Act 1970 and comply the relevant provisions of this Act in respect of the labour employed by him for executing this contract. The contractor shall furnish necessary returns to the authority through the Principal Employer.

50. Contractor shall insure all his labourers and material. Any claim by his Employees for damages shall be settled by the Contractor even if action is against BHEL or to reimburse the legal expenses incurred by BHEL.

51. Any action brought in by anybody on BHEL regarding patent, right etc., used by Contractor in execution of work shall be defended by the Contractor and / or reimburse BHEL the cost of the same.

52. Contractor shall produce necessary records, documents; explanation whenever he is called upon to do by any Government Agencies.

53. Contractor should obtain "Workmen Compensation Policy" for their Employees.

54. LEAD, LIFT, DEWATERING ETC.,

a) Unless otherwise specified in the tender schedule, the rates for all items will be deemed to include all leads, lifts and descents involved in the work.

b) No separate payment will be made for dewatering (including seepage, surface drainage and monsoon water) desludging and allied operations at any stage of the work, and the cost of such operations will be deemed to be included in the contract rates.

c) No separate payment will be made for curing including pumping of curing water where ever necessary.

55. EXTRA ITEMS

No extra items of work shall be carried out by the contractor other than those authorized to do so in writing by the Engineer-in-charge. For any such items of work executed as per instructions of Engineer-in-charge, the rates will be fixed on the basis indicated under clause 50 of BHEL GCC/as per terms and conditions of BHEL. The schedule of rates to be followed in this case will be CPWD schedule of rates.

SPECIAL CONDITONS OF CONTRACT

1. GENERAL

Tender Ref No. 191184

Part-A



The special conditions of contract and other contract documents are complimentary to each other and shall be read in conjunction with each other. In case of any conflict of meanings between the special conditions of contract and the BHEL General Conditions of Contract the provisions of the special conditions of contract shall override the corresponding provisions of the BHEL General Conditions of Contract.

2. SCOPE OF WORK

The scope of work includes for the full, final and entire completion of **Works contract for construction of foundation for calciner chimney** as detailed in specifications and drawings, which forms part of this Contract. The scope of work also includes cleaning/removing all debris in line with bill of quantity as directed by Engineer In-charge. The scope of work under this contract shall cover supply of all materials, labour, tools, and plants etc., unless otherwise specified in the specifications, descriptions of items or in foregoing clauses.

3. SITE CONDITIONS

- a) Before tendering the Contractor shall get themselves acquainted with site conditions such as the nature of soil likely to be encountered during the course of the work etc.,. The rates quoted by the contractor shall be deemed to have been quoted after getting acquainted with the prevailing site conditions. Initial jungle clearance, stripping of top soil etc., shall also be included in the quoted rates. No claims on the pretext of ignorance of site conditions shall be entertained.
- b) The site of work is as mentioned in the Tender document.

4. SITE FACILITIES

A. LAND

The Employer will allot land as available free of cost to the contractor for his office stores. He must maintain the areas allotted to him in a neat and clean conditions as required by the Employer. The contractor shall provide adequate storage and office facilities with approval from the Engineer. The rate quoted by the contractor shall be deemed to include for these and no separate payment will be made towards these. On completion of work, the site shall be cleaned by the contractor of all materials, temporary debris, rubbish plants and equipment's, belonging to the contractor at no extra cost. The site and surroundings shall be handed over in a neat and clean condition. In case of any failure by the contractor, the employer will get inside cleared at risk and cost of the Contractor.

B. POWER AND WATER SUPPLY

Facilities for drawing Power and water required at site for execution of the works shall be arranged by the contractor at his expense and risk. The necessary source for power & water supply has to be organized by vendor. Necessary distribution box, extension board points duly earthed, and with armoured safe power cables to be laid across the field provided point shall be in the scope of the tenderer. Further, laying of water intake and distribution pipes across the Site to various points of work from Electricity source provided water source point shall be in the scope of the tenderer. If required D.G generation sets shall be provided for Power arrangement by the contractor at his own cost. The tenderer shall make provision for temporary storage of water at suitable locations with pump if required to reach the water supply to work areas. The contractor will have to make his own arrangements for the same, without claiming any extra charge for the power and water drawal and distribution equipment.

5. MACHINERY

The Contractor shall at his own expense, supply all tools, plant and equipment (hereinafter referred to as T & P) required for execution of contract, as specified in the tender documents. whole of the works shall be executed in perfect conformity with the specifications and drawings. If contractor perform any works in a manner contrary to the specifications and drawings and without reference to the Engineer-in-charge, he shall bear all the costs arising or ensuring there from.

- a) All technical documents regarding the construction of works are given in the metric system and work should be carried out according to metric system.
- b) The work shall be carried out as per detailed drawings supplied by the employer. The working drawings shall be emailed progressively to the contractor free of cost. The contractor shall keep one set of drawings (duly protected from

Tender Ref No. 191184

Part-A



dust and wear and tear) at his own expenses always available at site for reference of Engineer-in-charge and other representatives.

d) The works shall be carried out as per detailed specifications enclosed with the tender. For items for which there is no mention in the drawings, detailed specification relevant IS specification (latest edition) shall be followed.

e) The contractor shall submit to the Employer for their approval complete drawings, of all temporary works and staging which he may require for carrying out the works shown in the drawings.

He shall at the same time if so required by the Employer submit his calculations relating to strength and anticipated deflection in respect of any aforesaid temporary works. He shall also submit for the approval of Employer drawings showing the methods he proposes to adopt for the erection of the various parts of the temporary works. Any modification to the drawings that may be required by the Employer shall be made by the contractor at his own cost. However, notwithstanding the approval of modification required for temporary works, the contractor shall be fully responsible for their efficiency, security and maintenance and for all obligations and risks in regard to such works, specified or implied in this contract and he shall reinstate the same at his own cost, should any mishap or accident occur causing damage or injury there from, subject however, to such clauses of the General conditions as may be applicable in such cases.

6. BENCH MARKS AND REFERENCE POINTS

The contractor shall construct and maintain proper benchmarks and reference points of the inter section of all main walls, no separate payment shall be made for this and rates quoted deemed to include this cost. Surveying where ever required is in contractor scope.

7. SAFETY PRECAUTIONS

The contractor shall at times observe the safety code and make necessary action as required in the tender. In default thereof, the employer may get this done departmentally or through other agencies and recover the cost from the contractor.

The Contractors shall also abide by all the security regulations promulgated from time to time by employer.

8. RATES

The rates to be quoted are intended to provide for works duly and properly completed in accordance with the general and special conditions of contract and specifications and drawings together with such alteration and/or conditions as may be required / ordered without prejudice to the generality thereof shall include for detail of construction which are obviously and fairly intended and which may not have been specifically referred in these documents and working drawings and but are essential for execution and satisfactory completion of work including those of minor nature and shall be deemed to include and cover internal the followings.

a) Arrangements for obtaining the clearance wherever required from statutory bodies, regarding license for construction, permanent electricity, water supply, and sanitary connections including payment of necessary fees, inspection charges and obtaining financial certificates for using these services. The various items rates quoted in the schedule as applicable shall be deemed to include the above services and no separate payments shall be made towards these.

b) The cost of all superintendence and labour materials, tools, plants, equipment's, mobilizing and demobilizing equipment fuel lubricants, fixture, transport charges, temporary and permanent works and quarrying charges, testing, screening, washing, handling of materials, stacking and removal charges, of any rejected materials and water and power arrangements and satisfactory maintenance of the same satisfactory completion of the work intended.

c) All fees, duties, royalties, rent and compensation to owner for surface damage or taxes and impositions payable to local authorities, in respect of land an structure, for all materials supplied for the work or any other duties/expenses for which the contractor may become liable or may be put to under any provision of the law for the purpose of in connection with the execution of the contract including levies payable on the transactions.



- d) Settings out of works profiles etc., and of construction repair and up-keep of all centre lines, bench marks and levels and page there of including provisions of masonry/concrete pillars showing the centre line of structure/gridlines and levels and maintenance and protection of the some including providing fencing etc., throughout the period of contract.
- e) Breaking, maintenance and removal of temporary works and buildings.
- f) Supply of complete, Moulds, cost of testing of materials etc.
- g) Working in all conditions including in/under water liquid, conditions etc., and shall also include bailing or pumping out water from the foundations, basements or any other sources of whatsoever de-sludging and allied operation at any stage of work including all suspension period and delays whatsoever. Cost of curing including pumping and cost of water whatever necessary.
- h) In the interest of completion of work within the stipulated time, certain works are to be carried out during the monsoon period also. No separate payment will be made to the contractor for such works and it will be deemed to be included in the contract rates.
- i) Diversion and draining works, protection works, temporary facilities, bridges, gangway.
- j) Work at all depth in foundation below the ground level and in superstructure up to all height above ground level including all lifts and distances involved at any other place of work and disposed/barrow areas.
- k) Unless otherwise specified in the specification schedule cost of all leads/lifts etc.
- l) Provision of centering, scaffolding, strutting props etc.,
- m) All materials and labour required for fencing in a protection against risk of accidents and for providing necessary/planking strutting with hand rails, gumboots, helmets, safety belts etc., during the progress of work.
- n) Prevention on trespassing by providing barrier arrangements for the safety of the public or employees during the provision of works.
- o) Works in all shapes include and curved all sizes as shown are as required.
- p) Cleaning the site after the completion of work all debris, left out construction materials machine equipment's, temporary offices, stores, works shop etc., including dressing the area neat and clean shape.
- q) Such other incidental charges or contingencies as may have been provided for in the specifications.

9. LABOUR COLONIES

Labour camp will not permitted within the project premises.

10. ESCALATION

The rates to be quoted by the tenderer shall be firm and shall cover and include all statutory levies, arising from, acts passed by parliament or by state legislature, the rates shall further be deemed to include statutory levies arising from such Acts, Central or State, which may come in to force subsequent to submission of tenders. The tenderer shall note that no claim for enhancement of rates, on the ground that existing statutory levies have been increased, or that new statutory levies have come in to effect after tender, or on any other ground, will be entertained on any account.

11. QUANTITY

The probable quantities of the several items of work are furnished in the schedule of quantities. It must be clearly understood that neither the probable quantities nor the value of individual items nor the aggregate value of the entire work shall be binding on the Employer/Engineer does not in any way assure the contractor or Guarantee that the said probable quantities are correct or that the work will correspond to these. The Employer/Engineer reserve the right to omit, vary or add to the item/work described in the schedule, of quantities and no claim for compensation will be entertaining on this account.

12. VARIATION/DEVIATION IN QUANTITIES

The contractor shall not make any alteration in addition to or omission from the work as described in the tender document except in pursuance of the written instructions of the Engineer-in-charge. No such deviation from the work described in the tender documents shall be valid unless the same has been specifically confirmed and accepted by the accepting officer in writing and incorporated in the contract. The rates quoted are firm.

Tender Ref No. 191184

Part-A



13. MATERIALS

BHEL will not supply any materials unless otherwise specified.

14. SUPPLY OF CEMENT, STEEL, PAINT AND OTHER CONSTRUCTION MATERIALS, IS TO BE MADE BY CONTRACTOR, Makes / Source of supply of cement, steel, paint and other construction materials shall be as per approval of BHEL

15. SUPPLY BY CONTRACTOR

The work is for a completed job including labour and supply of all materials except those otherwise specified in the bid document.

The material and works shall be subject to inspection and test as per field quality plan (FQP) duly approved by BHEL. All materials supplied by the contractor according to the contract conditions shall be subject to inspection and passing by the Engineer-in-charge or his representatives from time to time, the contractor providing all facilities for such instruction free of cost.

BHEL officers connected with the contract shall have the power at any time to inspect and examine any stores or materials intended to be used in or on the work, whether on the site or at any factory or workshop or other place where such stores or materials are being fabricated or manufactured or at any place the same are lying and the contractor shall give necessary facilities for such inspection and examination.

The Engineer-in-charge shall be entitled to have tests made of any stores or materials supplied by the contractor shall provide at his own expense all facilities which the Engineer-in-charge may require for this purpose. If at the discretion of the Engineer-in-charge an independent expert is employed to make any such tests his charges shall be borne by the contractor only if the tests disclosed that the said stores or materials are not in accordance with the provision of the contract.

Should the Engineer-in-charge/Civil Engineer consider at any time during the construction or reconstruction on prior to the expiry of the Maintenance Period that the stores or materials provided by the contractor are unsound or of quality inferior to that contracted for, or otherwise not in accordance with the contract (in respect where the decision of the Engineer-in-charge/Civil Engineer shall be final and conclusive) the contractor shall on demand, in writing from the Engineer-in-charge specifying the stores or materials complained of, notwithstanding that the same may have been inadvertently passed, certified that and paid forth with remove the stores or materials so specified and provide other and suitable stores or materials at his own expense, to the entire satisfaction of the Engineer-in-charge/Civil Engineer and in the event of his failing to do so within a period to be specified by the Engineer-in-charge/Civil Engineer, in his demand aforesaid, the Engineer-in-charge/Civil Engineer may replace within the other stores or materials complained of at the risk and expense in all respect of the contractor.

The liability of the contractor under this conditions, shall not extend beyond the maintenance period aforesaid except as regards stores or materials which the Engineer-in-charge/Civil Engineer shall have previously given notice to the contractor to replace (Maintenance period for any work under this organization will be six months from the date of actual completion of the particular work and handing over to BHEL).

16. INTERRUPTION TO THE WORKS

While quoting the rates/prices the Contractor should take in to account the fact that due to the design or other stipulations at site, or the necessity to follow a particular sequence of overall construction operation, or non-supply of particular drawings, or the connected work or other reasons, interruptions are likely to be encountered in a work of this nature and magnitude. No claims for such interruptions will be entertained on any account.

17. EXTENSION OF TIME OR PENALTY/LIQUIDATED DAMAGES (**LD**)

Extension of time or penalty/liquidated damages as the case may be will be determined as stipulated in clause No. 2.7.9 of BHEL General Conditions of Contract 2019.

18. COMPLETION OF WORK AND MEASUREMENT

a) All work shall be carried out according to authorized dimensions and measurement will be restricted to those authorized dimension even though the Contractor may for convenience of this work exceed the authorized dimensions.

Tender Ref No. 191184

Part-A



- b) All work shall be measured in accordance with the applicable standard method of measurements prescribed by the Indian Standard Institution (1200 latest edition) unless otherwise specified.
- c) The Contractor shall admit for technical inspection, works which are likely to be embedded or covered by other works and have the necessary measurement books and certificates to this effect duly signed by the Engineer before the works are covered.
- d) On completion of the work, the Contractor must submit to the Engineer the following documents for passing of works.
- i) A copy of the working drawing showing there on all addition and alterations in the process of execution.
- ii) A certificate for embedded and covered up works as in sub-para (C) above
- e) The authorized Contractors representative and a representative of the Employer shall jointly sign a certificate of handing over any completed work and date of signature of that certificate will be that the date from which the maintenance period of that unit will reckoned.
- f) Notwithstanding the above, insurance cover has to be taken by the contractor for the full value of work as also for the duration of the contract period. 50% of the Security Deposit shall be released only on the total completion of the building and handing over to BHEL to their satisfaction. Remaining 50% of Security Deposit shall be released subject to the stipulation in BHEL's GCC after 6 months from the date of completion of the building.

19. MAINTENANCE OF WORK

The contractor will be responsible for the maintenance of works during the period of construction until the various items are taken over, and for a further period of six months, from the date of taking over. If the contractor fails to maintain the building satisfactorily, it will be got done by other agency and cost towards such maintenance together with departmental charges will be recovered from his bills/dues.

20. SECURITY DEPOSIT

Upon acceptance of the tender, the successful tenderer shall remit the security deposit with Bharat Heavy Electricals Ltd within the time as specified in the Letter of Intent. The rate of Security Deposit will be 03% of work order value. The contractor should submit the Security Deposit before the start of the work by

- i) Cash (as permissible under the income Tax Act).
- ii) Pay order, demand draft in favor of BHEL.
- iii) Local cheques of scheduled banks, subject to realization.
- iv) Securities available from Post Offices such as National Saving Certificates, Kisan Vikas Patras etc.,(Certificate should be held in the name of contractor furnishing the security and duly pledged in favour of BHEL and discharged on the back).
- v) Bank Guarantee from scheduled Banks/Public financial Institutions as defined in the companies Act subject to a maximum of 50% of the total security deposit value. The balance 50% has to be remitted either by cash or in the other form of security. The Bank Guarantee format should have the approval of BHEL.
- vi) Fixed Deposit Receipt issued by scheduled Banks/Public Financial Institutions as defined in the Companies Act. The FDR should be in the name of the contractor, A/C BHEL, duly discharged on the back.
- vii) Security Deposit can also be recovered at the rate of 10% from the running bills. However in such cases at least 50% of the Security Deposit should be collected before start of the work and balance 50% may be recovered from the running bills.
- viii) EMD of the successful tenderer shall be converted and adjusted against the Security Deposit. The Security Deposit shall not carry any interest.

NOTE: Accepting of Security Deposit against Sl. No. (iv) and (vi) above will be subject to hypothecation or endorsement on the documents in favour on BHEL. However, BHEL will not be liable or responsible in any manner for the collection of interest or renewal of the documents or in any other matter connected therewith.

For extra items of work and deviated quantities, security deposit will be recovered at 10% of the value of deviated amount. The security deposit will be released as stipulated under relevant clause of GCC 2019.

Tender Ref No. 191184

Part-A



21. RUNNING ACCOUNT PAYMENTS

During execution of work, after completion of the work payments of all works will be made on the basic measurements recorded in measurement sheet/ book in respect of items executed but no claim on the account will be entertained, if for any reason payments are not so made.

PRICE VARIATION clause not applicable.

22.1 MOBILIZATION ADVANCE/ADVANCE PAYMENT - NOT APPLICABLE

22.2 INTEREST & RECOVERY - NOT APPLICABLE

23. Statutory Deduction towards Income Tax will be made as per rules.

24. In respect of all labour directly or indirectly employed on the work by the Contractor, the Contractor shall comply with the provisions of the contract labour (Regulation and Abolition) Act 1970 or any amendment thereof and all legislations and rules of the State and or Central Government or other Authority (Whichever is higher), framed from time to time governing the protection of health, sanitary arrangements, wages, welfare and safety for labour employed on building and construction works. The rules and other statutory obligations with regard to fair wages, welfare and safety measures, maintenance of the register etc., will be deemed to be part of the contract.

25. The Contractor is required to take insurance for all workers employed on works towards payment for workmen compensation. The insurance has to be taken out within 15 days of the award of work and has to be produced at the time of signing agreement. Half (1/2%) shall be deducted for every bill if the contractor fails to produce a proof of having taken such an insurance to cover his workmen. However, the contractor shall be fully responsible for all the consequences arising out of such default. This may also be read with relevant clauses of BHEL GCC 2019.

25. TIME OF COMPLETION

The date of commencement of work shall be counted from the date of handing over the site to the contractor. It may be clearly understood that time is the essence of the contract and the entire work should be completed within the time imposed in the tender document letter of intent.

26. The Contractor has to pay the Works Contract Tax (Under relevant section of the State Government Act) of their own on Monthly basis.

27. The management of BHEL shall be at liberty to terminate the contract by issuing a month's notice to the contractor without assigning any reason what so ever. As regards unsatisfactory performance or noncompliance with any of the terms & conditions of the contract by the contractor. The management of BHEL shall have the right to terminate the contractor forthwith without notice & rearrange the balance work through other agencies at the risk & cost of the contractor & under such circumstances, the Earnest Money Deposit/Security Deposit paid by the contractor shall stand forfeited.

28. SPECIAL CONDITIONS OF TENDER

i) The successful bidder should open local office for Technical staff/Administrative group at Bangalore City for easy interactions/ monitoring of work at site. / Attend meetings at Bangalore city/site as and when instructed by BHEL. As applicable

ii) Tenderers should not disclose any price bid details/discounts in the technical bids.

iii) The successful bidder should construct site office / toilets for their workmen at site in consultation with Engineer-in-charge. As applicable

29. WORKMEN COMPENSATION POLICY

The contractor is required to take Insurance for all the workers employed on the works towards payments for workmen compensation. The Insurance has to be taken out within 15 days of the award of work and has to be provided at the time of signing the agreement. Half percent (0.5%) of the amount shall be deducted from every bill if the contractor fails to produce a proof of having taken such an insurance to cover his workmen. However, the contractor shall be fully responsible for the consequences arising out of such default.



BHARAT HEAVY ELECTRICALS LIMITED
Solar Business Division, Malleswaram,
Bengaluru - 560 012

TENDER DOCUMENT
(PART - A)

FORM OF TENDER

Having examined the invitation to bid, Instructions to Bidder, General conditions of contract, Special conditions, Specifications tender schedule, Contract drawings and other documents for the above work, we the undersigned, offer to construct, erect complete and maintain the whole of the said in conformity with the said bid documents on the terms and conditions and under the provisions set out or called for in the contract documents at the rates listed in the schedule of unit prices or elsewhere in the contract documents.

We undertake if our bid is accepted, to commence the works within 7 days from the date of issue of award and to complete and delivery the whole of the works comprised in the contract as per the time schedule agreed to the contract document.

We agree to abide by this bid for the period as per NIT terms from the date fixed for receiving the same and it shall remain binding upon us and may be accepted at any time before expiry of the period.

Until and unless a formal agreement is prepared and executed this bid, together with your award thereof shall constitute a binding contract between us.



ANNEXURE I A :

MODEL CONCILIATION CLAUSE FOR CONDUCT OF CONCILIATION UNDER THE BHEL CONCILIATION SCHEME, 2018.

BRIEF PROCEDURE FOR CONDUCT OF CONCILIATION PROCEEDINGS

The proceedings of Conciliation shall broadly be governed by Part-III of the Arbitration and Conciliation Act 1996 or any statutory modification thereof and as provided herein:

The party desirous of resorting to Conciliation shall send an invitation/notice in writing to the other party to conciliate specifying all points of Disputes with details of the amount claimed. The party concerned shall not raise any new issue thereafter. Parties shall also not claim any interest on claims/counter-claims from the date of notice invoking Conciliation till the conclusion of the Conciliation proceedings. If BHEL is to initiate Conciliation, then, the invitation to Conciliate shall be extended to the concerned Stakeholder in Format 7 hereto. Where the stakeholder is to initiate the Conciliation, the notice for initiation of Conciliation shall be sent in Format-8 hereto.

The party receiving the invitation/notice for Conciliation shall within 30 days of receipt of the notice of Conciliation intimate its consent for Conciliation along with its counter-claims, if any.

The Conciliation in a matter involving claim or counter-claim (whichever is higher) up to Rs 5 crores shall be carried out by sole Conciliator nominated by BHEL while in a matter involving claim or counter-claim (whichever is higher) of more than Rs 5 crores Conciliation shall be carried out by 3 Conciliators nominated by BHEL. The appointment of Conciliator(s) shall be completed and communicated by the concerned Department/Group of BHEL Unit/Division/Region/Business Group to the other party and the Conciliator(s) within 30 days from the date of acceptance of the invitation to conciliate by the concerned party in the Format-9. The details of the Claim, and counter-claim, if any, shall be intimated to the Conciliator(s) simultaneously in Format-5.

The Parties shall be represented by only their duly authorized in-house executives/officers and neither Party shall be represented by a Lawyer.

The first meeting of the IEC shall be convened by the IEC by sending appropriate communication/notice to both the parties as soon as possible but not later than 30 days from the date of his/their appointment. The hearings in the Conciliation proceeding shall ordinarily be concluded within two (2) months and, in exceptional cases where parties have expressed willingness to settle the matter or there exists possibility of settlement in the matter, the Proceedings may be extended by the IEC by a maximum of further 2 months with the consent of the Parties subject to cogent reasons being recorded in writing.

The IEC shall thereafter formulate recommendations for settlement of the Disputes supported by reasons at the earliest but in any case within 15 days from the date of conclusion of the last hearing. The recommendations so formulated along with the reasons shall be furnished by the IEC to both the Parties at the earliest but in any case within 1 month from the date of conclusion of the last hearing.

Response/modifications/suggestions of the Parties on the recommendations of the IEC are to be submitted to the IEC within time limit stipulated by the IEC but not more than 15 days from the date of receipt of the recommendations from the IEC.

In the event, upon consideration, further review of the recommendations is considered necessary, whether by BHEL or by the other Party, then, the matter can be remitted back to the IEC with request to reconsider the same in light of the issues projected by either/both the Parties and to submit its recommendations thereon within the following 15 days from the date of remitting of the case by either of the Parties.

Upon the recommendations by the Parties, with or without modifications, as considered necessary, the IEC shall be called upon to draw up the Draft Settlement Agreement in terms of the recommendations.



When a consensus can be arrived at between the parties only in regard to any one or some of the issues referred for Conciliation the draft Settlement Agreement shall be accordingly formulated in regard to the said Issue(s), and the said Settlement Agreement, if signed, by the parties, shall be valid only for the said issues. As regards the balance issues not settled, the parties may seek to resolve them further as per terms and conditions provided in the contract.

In case no settlement can be reached between the parties, the IEC shall by a written declaration, pronounce that the Conciliation between the parties has failed and is accordingly terminated.

Unless the Conciliation proceedings are terminated in terms of para 22 (b), (c) & (d) herein below, the IEC shall forward his/its recommendations as to possible terms of settlement within one (1) month from the date of last hearing. The date of first hearing of Conciliation shall be the starting date for calculating the period of 2 months.

In case of 3 members IEC, 2 members of IEC present will constitute a valid quorum for IEC and meeting can take place to proceed in the matter after seeking consent from the member who is not available. If necessary, videoconferencing may be arranged for facilitating participation of the members. However, the IEC recommendations will be signed by all members. Where there is more than one (1) Conciliator, as a general rule they shall act jointly. In the event of differences between the Members of IEC, the decision/recommendations of the majority of the Members of IEC shall prevail and be construed as the recommendation of the IEC.

The Draft Settlement Agreement prepared by the IEC in terms of the consensus arrived at during the Conciliation proceedings between the Parties shall be given by the IEC to both the parties for putting up for approval of their respective Competent Authority.

Before submitting the draft settlement agreement to BHEL's Competent Authority viz. the Board Level Committee on Alternative Dispute Resolution (BLCADR) for approval, concurrence of the other party's Competent Authority to the draft settlement agreement shall be obtained by the other party and informed to BHEL within 15 days of receipt of the final draft settlement agreement by it. Upon approval by the Competent Authority, the Settlement Agreement would thereafter be signed by the authorized representatives of both the Parties and authenticated by the members of the IEC.

In case the Draft Settlement Agreement is rejected by the Competent Authority of BHEL or the other Party, the Conciliation proceedings would stand terminated.

A Settlement Agreement shall contain a statement to the effect that each of the person(s) signing thereto (i) is fully authorized by the respective Party(ies) he/she represents, (ii) has fully understood the contents of the same and (iii) is signing on the same out of complete freewill and consent, without any pressure, undue influence.

The Settlement Agreement shall thereafter have the same legal status and effect as an arbitration award on agreed terms on the substance of the dispute rendered by an arbitral tribunal passed under section 30 of the Arbitration and Conciliation Act, 1996.

Acceptance of the Draft Settlement Agreement/recommendations of the Conciliator and/or signing of the Settlement Agreement by BHEL shall however, be subject to withdrawal/closure of any arbitral and/or judicial proceedings initiated by the concerned Party in regard to such settled issues.

Unless otherwise provided for in the agreement, contract or the Memorandum of Understanding, as the case may be, in the event of likelihood of prolonged absence of the Conciliator or any member of IEC, for any reason/incapacity, the Competent Authority/Head of Unit/Division/Region/Business Group of BHEL may substitute the Conciliator or such member at any stage of the proceedings. Upon appointment of the substitute Conciliator(s), such reconstituted IEC may, with the consent of the Parties, proceed with further Conciliation into the matter either de-novo or from the stage already reached by the previous IEC before the substitution.

The proceedings of Conciliation under this Scheme may be terminated as follows:

On the date of signing of the Settlement agreement by the Parties; or,

By a written declaration of the IEC, after consultation with the parties, to the effect that further efforts at conciliation are no longer justified, on the date of the declaration; or,



By a written declaration of the Parties addressed to the IEC to the effect that the Conciliation proceedings are terminated, on the date of the declaration; or,
By a written declaration of a Party to the other Party and the IEC, if appointed, to the effect that the Conciliation proceedings are terminated, on the date of the declaration; or,
On rejection of the Draft Settlement Agreement by the Competent Authority of BHEL or the other Party.
The Conciliator(s) shall be entitled to following fees and facilities:

SI No	Particulars	Amount
1	Sitting fees	Each Member shall be paid a Lump Sum fee of Rs 75,000/- for the whole case payable in terms of paragraph No. 27 herein below.
2	Towards drafting of settlement agreement	In cases involving claim and/or counter-claim of up to Rs 5crores. Rs 50,000/- (Sole Conciliator) In cases involving claim and/or counter-claim of exceeding Rs 5 crores but less than Rs 10 crores. Rs 75,000 (per Conciliator) In cases involving claim and/or counter-claim of more than Rs 10 crores. Rs 1,00,000/- (per Conciliator) Note: The aforesaid fees for the drafting of the Settlement Agreement shall be paid on the,Signing of the Settlement Agreement after approval of the Competent Authority or Rejection of the proposed Settlement Agreement by the Competent Authority of BHEL.
3	Secretarial expenses	Rs 10,000/- (one time) for the whole case for Conciliation by a Sole Member IEC. Where Conciliation is by multi member Conciliators –Rs 30,000/- (one time)- to be paid to the IEC
4	Travel and transportation	As per entitlement of equivalent officer (pay scale wise) in BHEL
	Others	As per the extant entitlement of whole time Functional Directors in BHEL. Ordinarily, the IEC Member(s) would be entitled to travel by air Economy Class
5	Venue for meeting	Unless otherwise agreed in the agreement, contract or the Memorandum of Understanding, as the case may be, the venue/seat of proceedings shall be the location of the concerned Unit / Division / Region / Business Group of BHEL. Without prejudice to the seat/venue of the Conciliation being at the location of concerned BHEL Unit / Division / Region / Business Group, the IEC after consulting the Parties may decide to hold the proceedings at any other place/venue to facilitate the proceedings. Unless, Parties agree to conduct Conciliation at BHEL premises, the venue is to be arranged by either Party alternately.

1. The parties will bear their own costs including cost of presenting their cases/evidence/witness(es)/expert(s) on their behalf. The parties agree to rely upon documentary evidence in support of their claims and not to bring any oral evidence in IEC proceedings.
2. If any witness(es) or expert(s) is/are, with the consent of the parties, called upon to appear at the instance of the IEC in connection with the matter, then, the costs towards such witness(es)/expert(s) shall be determined by the IEC with the consent of the Parties and the cost so determined shall be borne equally by the Parties.



3. The other expenditures/costs in connection with the Conciliation proceedings as well as the IEC's fees and expenses shall be shared by the Parties equally.
4. Out of the lump sum fees of Rs 75,000/- for Sitting Fees, 50% shall be payable after the first meeting of the IEC and the remaining 50% of the Sitting Fees shall be payable only after termination of the conciliation proceedings in terms of para 22 hereinabove.
5. The travelling, transportation and stay at outstation shall be arranged by concerned Unit as per entitlements as per Serial No. 4 of the Table at para 23 above, and in case such arrangements are not made by the BHEL Unit, the same shall be reimbursed to the IEC on actuals limited to their entitlement as per Serial No. 4 of the Table at Para 23 above against supporting documents. The IEC Member(s) shall submit necessary invoice for claiming the fees/reimbursements.
6. The Parties shall keep confidential all matters relating to the conciliation proceedings. Confidentiality shall extend also to the settlement agreement, except where its disclosure is necessary for purposes of its implementation and enforcement or as required by or under a law or as per directions of a Court/Governmental authority/ regulatory body, as the case may be.
7. The Parties shall not rely upon or introduce as evidence in any further arbitral or judicial proceedings, whether or not such proceedings relate to the Disputes that is the subject of the Conciliation proceedings:
 - a. Views expressed or suggestions made by the other party in respect of a possible settlement of the Disputes;
 - b. admissions made by the other party in the course of the Conciliator proceedings;
 - c. proposals made by the Conciliator;
 - d. The fact that the other Party had indicated his willingness to accept a proposal for settlement made by the Conciliator.
8. The Parties shall not present the Conciliator(s) as witness in any Alternative Dispute Resolution or Judicial proceedings in respect of a Disputes that is/was the subject of that particular Conciliation proceeding.
9. None of the Conciliators shall act as an arbitrator or as a representative or counsel of a Party in any arbitral or judicial proceeding in respect of a Disputes that is/was the subject of that particular Conciliation proceeding.
10. The Parties shall not initiate, during the Conciliation proceedings, any arbitral or judicial proceedings in respect of a Disputes that is the subject matter of the Conciliation proceedings except that a Party may initiate arbitral or judicial proceedings where, in his opinion, such proceedings are necessary for preserving his rights including for preventing expiry of period of limitation. Unless terminated as per the provisions of this Scheme, the Conciliation proceedings shall continue notwithstanding the commencement of the arbitral or judicial proceedings and the arbitral or judicial proceedings shall be primarily for the purpose of preserving rights including preventing expiry of period of limitation.
11. The official language of Conciliation proceedings under this Scheme shall be English unless the Parties agree to some other language.



Format 5

BHEL Conciliation Scheme, 2018 STATEMENT OF CLAIMS/COUNTER CLAIMS TO BE SUBMITTED TO THE IEC BY BOTH THE PARTIES

1. Chronology of the Disputes
2. Brief of the Contract/MoU/Agreement/LOI/LOA
3. Brief history of the Disputes:
4. Issues:
5. Details of Claim(s)/Counter Claim(s):

SI. No.	Description of claim(s)/Counter Claim	Amount (in INR)Or currency applicable in the contract	Relevant contract clause

6. Basis/Ground of claim(s)/counter claim(s) (along with relevant clause of contract)

Note– The Statement of Claims/Counter Claims may ideally be restricted to maximum limit of 20 pages. Relevant documents may be compiled and submitted along with the statement of Claims/Counter Claims. The statement of Claims/Counter Claims is to be submitted to all IEC members and to the other party by post as well as by email.



FORMAT-7

FORMAT FOR NOTICE INVOKING CONCILIATION CLAUSE BY BHEL FOR REFERRING THE DISPUTES TO CONCILIATION THROUGH IEC

To,

M/s. (Stakeholder's name)

Subject: NOTICE FOR INVOCATION OF THE CONCILIATION CLAUSE OF THE CONTRACT BY BHEL

Ref: ContractNo/MoU/Agreement/LOI/LOA& date _____.

Dear Sir/Madam,

As you are aware, with reference to above referred Contract/MoU/Agreement/LOI/LOA, certain disputes have arisen, which, in spite of several rounds of mutual discussions and various correspondences have remained unresolved. The brief particulars of our claims which arise out of the above-referred Contract/MoU/Agreement/LOI/LOA are reproduced hereunder:

Sl. No.	Claim description	Amount involved

As you are aware, there is a provision in the captioned Contract/MoU/Agreement/LOI/ LOA for referring disputes to conciliation.

In terms of Clause -----of Procedure i.e., Annexure ----- to the Contract/MoU /Agreement / LOI / LOA, we hereby seek your consent to refer the matter to Conciliation by Independent Experts Committee to be appointed by BHEL. You are invited to provide your consent in writing to proceed with conciliation into the above mentioned disputes within a period of 30 days from the date of this letter along with details of counter-claims, if any, which you might have with regard to the subject Contract/ MoU/ Agreement/ LOI/ LOA.

Please note that upon receipt of your consent in writing within 30 days of the date of receipt of this letter by you, BHEL shall appoint suitable person(s) from the BHEL Panel of Conciliators.

This letter is being issued without prejudice to our rights and contentions available under the contract and law.

Thanking you Yours
faithfully
Representative of BHEL

Note: The Format may be suitably modified, as required, based on facts and circumstances of the case.



FORMAT-8

FORMAT FOR NOTICE INVOKING CONCILIATION CLAUSE BY A STAKEHOLDER FOR REFERRING THE DISPUTES TO CONCILIATION THROUGH IEC

To,
BHEL (Head of the Unit/Division/Region/Business Group)

Subject: NOTICE FOR INVOCATION OF THE CONCILIATION CLAUSE OF THE CONTRACT BY A STAKEHOLDER

Ref:ContractNo/MoU/Agreement/LOI/LOA& date_____.

Dear Sir/Madam,

As you are aware, with reference to above referred Contract/MoU/Agreement/LOI/LOA, certain disputes have arisen, which, in spite of several rounds of mutual discussions and various correspondences have remained unresolved. The brief particulars of our claims which have arisen out of the above- referred Contract/MoU/Agreement/LOI/LOA are enumerated hereunder:

Sl. No.	Claim description	Amount involved

As you are aware, there is a provision in the captioned Contract/MoU/Agreement/LOI/ LOA for referring inter-se disputes of the Parties to conciliation.

We wish to refer the above-said disputes to Conciliation as per the said Clause of the captioned Contract/MoU/Agreement/LOI/ LOA. In terms of Clause -----of Procedure i.e., Annexure ----- to the Contract/MoU /Agreement / LOI / LOA, we hereby invite BHEL to provide its consent in writing to proceed with conciliation into the above mentioned disputes within a period of 30 days from the date of this letter along with details of counter-claims, if any, which it might have with regard to the subject Contract/ MoU/ Agreement/ LOI/ LOA and to appoint suitable person(s) as Conciliator(s) from the BHEL Panel of Conciliators.

This letter is being issued without prejudice to our rights and contentions available under the contract and law.

Thanking you
Yours faithfully
Representative of the Stakeholder

Note: The Format may be suitably modified, as required, based on facts and circumstances of the case.



FORMAT-9

FORMAT FOR INTIMATION TO THE STAKEHOLDER ABOUT APPOINTMENT OF CONCILIATOR/IEC

To,

M/s. (Stakeholder's name)

Subject: INTIMATION BY BHEL TO THE STAKEHOLDER AND CONCILIATOR(S) ABOUT APPOINTMENT OF CONCILIATOR/IEC

Ref:ContractNo/MoU/Agreement/LOI/LOA& date_____. Sir,

This is with reference to letter dated ----- regarding reference of the disputes arising in connection with the subject Contract No /MoU/Agreement/LOI/LOA to conciliation and appointment of Conciliator(s).

In pursuance of the said letter, the said disputes are assigned to conciliation and the following persons are nominated as Conciliator(s) for conciliating and assisting the Parties to amicably resolve the disputes in terms of the Arbitration & Conciliation Act, 1996 and the Procedure ---- to the subject Contract/MoU/Agreement/LOI/LOA, if possible. Name and contact

details of Conciliator(s)

- a)
- b)
- c)

You are requested to submit the Statement of Claims or Counter-Claims (strike off whichever is inapplicable) before the Conciliator(s) in Format 5 (enclosed herewith) as per the time limit as prescribed by the Conciliator(s).

Yours faithfully,

Representative of BHEL

CC: To Conciliator(s)... for Kind Information please. Encl: As above

Note: The Format may be suitably modified, as required, based on facts and circumstances of the case.



Reverse Auction Form

Event Information

The "BHEL" has contracted to conduct this online bidding event. Service Provider shall answer all questions relating to the bidding process and conduct of the Reverse Auction Event.

1. Scheduled Date & Time of the event:
WILL BE INTIMATED BY

Any change in the scheduled time will be duly informed to you in advance.

2. Contact Information

"BHEL-SBD"

A. General Contract related Queries

Name:
Designation:
Tel Nos.
E-mail ID:
Mobile No:

"Service Provider"

Software Related Queries/ Process related Queries

Name:
Designation:
Tel Nos.
E-mail ID:

TO BE INTIMATED LATER



Process Compliance Form

To
Service Provider,

-----.

Sub: Agreement to the Process related Terms and Conditions

Dear Sir,

This has reference to the Terms & Conditions for the Reverse Auction mentioned in the bid document for ----- (Items) against BHEL Tender No. dated

This letter is to confirm that:

- 1) The undersigned is authorized official of the company.
- 2) We have studied the Reverse Auction Terms & Conditions and the Business rules governing the Reverse Auction as mentioned in your letter and confirm our agreement to them.
- 3) We also confirm that we have taken the training on the auction tool and have understood the functionality of the same thoroughly.

We, hereby confirm that we will honor the Bids placed by us during the auction process.

With regards

Signature with company seal -

Name -

Company / Organization -

Designation within Company / Organization -

Address of Company / Organization -



AGREEMENT BETWEEN CONTRACTOR AND BHEL- SBD

This Agreement made on this _____ day of _____ Two Thousand and Nine between M/s / Shri _____ aged about _____ years S/O of Shri _____, residing at _____, hereinafter called the "**Contractor**" (which expression shall unless repugnant to the context or meaning thereof be deemed to mean and include its successors and permitted assigns) of the First part.

AND

BHARAT HEAVY ELECTRICALS LIMITED, SOLAR BUSINESS DIVISION, Prof. CNR Circle, P.B.1245, IISc Post, Malleswaram, BENGALURU-560012, a Company incorporated under the Companies Act 1956 and having its registered office at BHEL House, Siri Fort New Delhi - 110049, **hereinafter called " BHEL-SBD "** (which expression shall unless repugnant to the context or meaning thereof be deemed to mean and include its successors and permitted assigns) of the second part.

Whereas

1. BHEL, SBD is desirous of entrusting to the said contractor to engage and carryout the contract job of more specifically mentioned in the Annexure (hereinafter called the Contract work) to this Agreement.
2. The Contractor who is a specialized agency in the type of contract work in different establishments has agreed to undertake the said contract work on job contract basis.

NOW THEREFORE IT IS AGREED BETWEEN THE PARTIES:

The Terms and conditions of this agreement are as stipulated in:

- (i) Notice Inviting Tender
- (ii) Scope of Work
- (iii) Proforma for Offering Techno-Commercial Bid
- (iv) Special Terms & Conditions of the Contract
- (v) General Terms and Conditions
- (vi) Duties and Responsibilities of Contractor
- (vii) Price Bid Format
- (viii) Declaration By Contractor
- (ix) Any minutes of the meeting & written understanding between BHEL & Contractor
- (x) Work Orders and Work Instructions issued to the Contractor
- (xi) Agreement between Contractor and BHEL-SBD

Shall form part and parcel of this agreement.

IN WITNESS WHEREOF THE PARTIES HERETO through their authorized Representatives have signed these presents on the day, month and year mentioned above.

For and on behalf of M/s-----



BHARAT HEAVY ELECTRICALS LIMITED
Solar Business Division, Malleswaram,
Bengaluru - 560 012

TENDER DOCUMENT
(PART - A)

[Authorized signatory]

Name & Designation

Witness : 1

Signature :

Designation :

Address :

For and on behalf of
Bharat Heavy Electricals Limited
Solar Business Division,
Bengaluru 560012.

[Authorized signatory]

Name & Designation

Witness : 2

Signature :

Designation :

Address :



THIRD PARTY NON-DISCLOSURE AGREEMENT

I, _____ on behalf of the _____ (Name of Company),

acknowledge that the information received or generated, directly or indirectly, while working with BHEL on contract is confidential and that the nature of the business of the BHEL is such that the following conditions are reasonable, and therefore:

I warrant and agree as follows:

I, or any other personnel employed or engaged by our company, agree not to disclose, directly or indirectly, any information related to the BHEL. Without restricting the generality of the foregoing, it is agreed that we will not disclose such information consisting but not necessarily limited to:

- Technical information: Methods, drawings, processes, formulae, compositions, systems, techniques, inventions, computer programs/data/configuration and research projects.
- Business information: Customer lists, project schedules, pricing data, estimates, financial or marketing data,

On conclusion of contract, I, or any other personnel employed or engaged by our company shall return to BHEL all documents and property of BHEL, including but not necessarily limited to: drawings, blueprints, reports, manuals, computer programs/data/configuration, and all other materials and all copies thereof relating in any way to BHEL's business, or in any way obtained by me during the course of contract. I further agree that I, or any others employed or engaged by our company shall not retain copies, notes or abstracts of the foregoing.

This obligation of confidence shall continue after the conclusion of the contract also.

I acknowledge that the aforesaid restrictions are necessary and fundamental to the business of the BHEL, and are reasonable given the nature of the business carried on by the BHEL. I agree that this agreement shall be governed by and construed in accordance with the laws of country.

I enter into this agreement totally voluntarily, with full knowledge of its meaning, and without duress.

Dated at _____, this _____ day of _____ 20 .

Name

Company

Signature



Format for E-payment (To be certified from the concerned Bank)

To:

AGM (Finance)

BHEL-SBD/ Bengaluru
Opp. Indian Institute of Science
Prof. CNR Rao Circle
Bengaluru – 560012

Subject: E-payments vide RTGS/NEFT.

I/ We request and authorize you to effect E-payment vide any two modes to my/ our bank account as per the details given below:

Vendor Name	:	
Title/ Name of Account in the bank	:	
Account Type (Saving/ Current)	:	
Bank Account Number	:	<input type="text"/>
Name and address of bank	:	
Bank/ Branch contact person name	:	
Bank. Branch phone numbers with STD code	:	
Bank Branch MICR code	:	<input type="text"/>
Bank Branch RTGS IFSC code	:	<input type="text"/>
Bank Branch NEFT IFSC code	:	<input type="text"/>
Your E-mail address	:	
Name of the Authorized Signatory	:	
Contact person Name	:	

I/ We confirm that information provided above is correct & any consequences due to any mistake in above will be borne by us.

Thanking you,

For

(Authorized Signatory)

We confirm that we are enabled for receiving RTGS/ NEFT credits and we further confirm that he account number of (please mention here the name of account holder) _____, the signature of the Authorized Signatory and MICR and IFSC codes of our branch mentioned above are correct.

Bank's Verification
(Manager's/ Officer's signature under bank stamp)
Note: Please attach cancelled original cheque leaf.



Bank Detail (For EMD submission as applicable):
Bharat Heavy Electricals Limited Solar Business Division Prof. CNR Rao Circle
Malleswaram Bengaluru-560012

1	Name of the Beneficiary:	Bharat Heavy Electricals Limited Ceramic Business Unit Prof. CNR Rao Circle Malleswaram Bengaluru-560012
2	Name of the Bank & Branch:	IDBI Bank Limited, Trade Finance
3	Address of the Branch:	Trade Finance IDBI House,58, 1 st Floor, Mission road, Bengaluru-560027
4	Bank Telephone No:	080-2227 9576
5	NEFT IFSC code	IBKL0000377
6	Account Type:	Current
7	Account No.	008103000003605
8	RTGS IFSC code:	IBKL0000377



BHARAT HEAVY ELECTRICALS LIMITED
Solar Business Division, Malleswaram,
Bengaluru - 560 012

TENDER DOCUMENT
(PART - A)

QR-CODE for EMD Submission

Powered by

IDBI BANK

BHIM BHARAT INTERFACE FOR MONEY

UPI UNIFIED PAYMENTS INTERFACE

SCAN & PAY

40112017000007870222480000000000

BHARAT HEAVY ELECTRICALS LIMITED

Payment Accepted from all UPI Apps.

सभी UPI Apps से
भुगतान स्वीकार किया जाता है।



Tender Enquiry No & Date:

Work Description:

SITE INSPECTION CERTIFICATE

This is to Certify that, I / We.....
..... had inspected the proposed
Construction site thoroughly and understood the scope of works to be carried out in
line with construction drawings/designs/data/Bill of quantities/schedule of items /
Specifications as brought out in the Tender as desired by BHEL.

Agreeable to all Terms & Conditions of Contract and assure to complete the work
Within the stipulation time frame.

Note: In case of bidder unable to visit the site due to any reason, bidder may kindly note that it is the responsibility of the bidder to ensure and understand the scope of work and site condition in line with NIT terms and condition.

Signature of the contractor

Name:
Seal



BHARAT HEAVY ELECTRICALS LIMITED
Solar Business Division, Malleswaram,
Bengaluru - 560 012

TENDER DOCUMENT
(PART - A)

Declaration in contractor's Letter head

Tender Enquiry No & Date:

Work Description:

Subject: Certification of MSE or Qualifying PPP-MII ,Order 2017

I/We hereby declare that,

I/We.....

Belong to MSE (or) qualifying PPP-MII, order2017 (relevant supporting documents attached). We also hereby declare that the information provided is correct to the best of my knowledge.

Seal & Signature of Authorized Representative /Bidder

Name:

Designation: Date:

Name of Bidder:

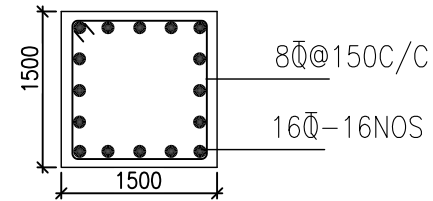

REINFORCEMENT DETAIL OF PEDESTAL

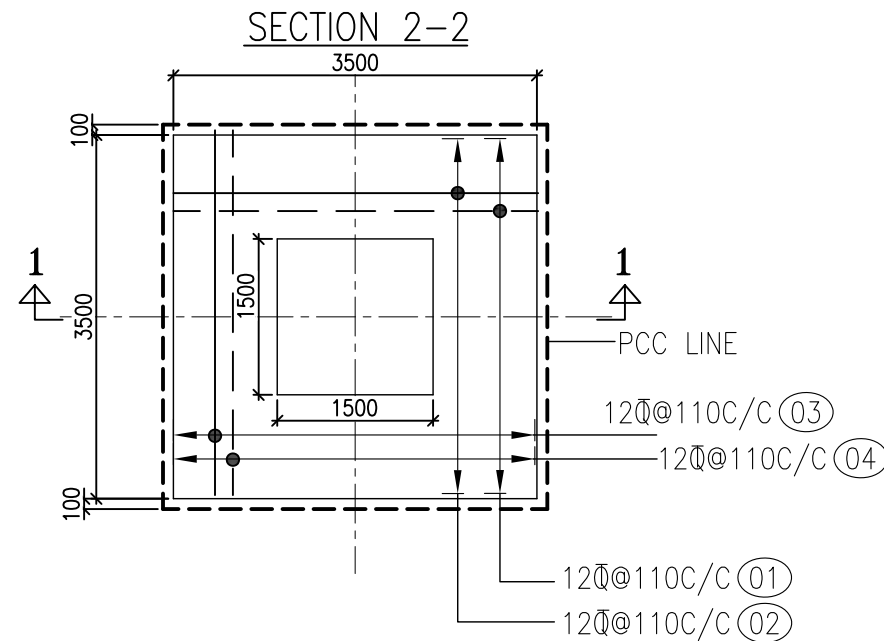

REINFORCEMENT DETAIL OF FOUNDATION PAD

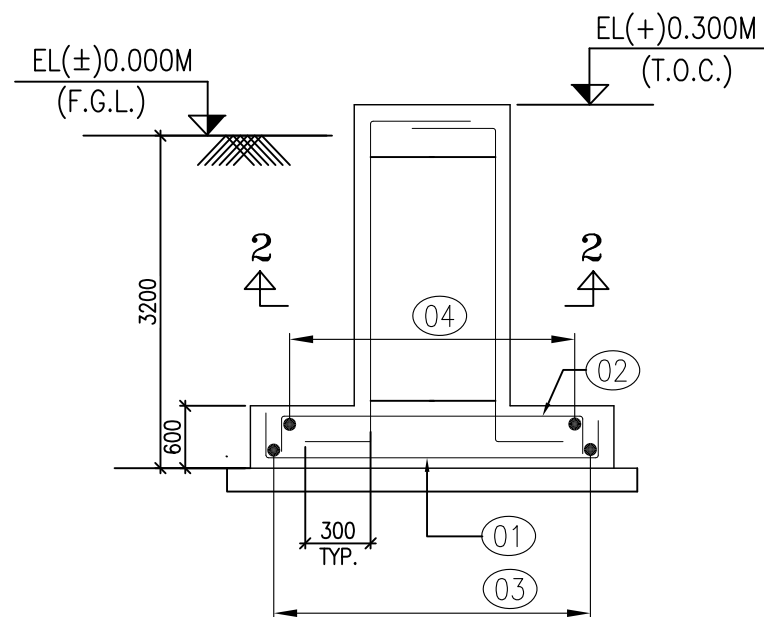

SECTION 1-1

PLAN AT FOUNDATION LVL.

NOTES:-

1. ALL DIMENSIONS ARE IN MM & LEVELS ARE IN METRES.
2. FIGURED DIMENSIONS ONLY SHALL BE FOLLOWED.
3. THIS DRAWING SHALL BE READ IN CONJUNCTION WITH RELEVANT MECH DWG.
4. ALL R.C.C. SHALL BE MIX M-25
5. REINFORCEMENT STEEL SHALL BE OF HIGH STRENGTH DEFORMED TMT STEEL BARS OF GRADE MINIMUM FE-500 AND SHALL CONFORM TO IS: 1786. DUCTILE DETAILING IN ACCORDANCE WITH IS: 13920 SHALL BE ADOPTED FOR SUBSTRUCTURE
6. CLEAR COVER TO REINF. INCLUDING LINKS FOR R.C.C MEMBERS SHALL BE AS UNDER:- FOOTING= 50mm, WALL= 40mm
7. STANDARD 'L' HOOKS SHALL BE PROVIDED AT THE ENDS OF ALL BARS.
8. PROVIDED LAP LENGTH/DEVELOPMENT LENGTH 'L' FOR BOTH COMPRESSION AND TENSION MAIN R/F BAR SHALL BE=50XDIA OF BAR
9. LAPS SHALL BE STAGGERED AND AVOIDED AT THE SECTIONS OF MAX. BENDING MOMENT
10. NET SAFE BEARING CAPACITY HAS BEEN TAKEN AS 15 T /SQM AT 1.5M BELOW F.G.L
11. BOTTOM BAR INDICATES :-
12. TOP BAR INDICATES :-

LEGEND:

- F.G.L. - FINISHED GROUND LEVEL
- F.F.L. - FINISHED FLOOR LEVEL
- T.O.C. - TOP OF CONCRETE
- THK. - THICKNESS
- TYP. - TYPICAL
- U.N.O. - UNLESS NOTED OTHERWISE
- CL - CENTER LINE
- B.O.B. - BOTTOM OF BEAM
- T.O.B. - TOP OF BEAM
- A.L.T. - ALTERNATE

REINFORCEMENT DETAILS OF CHIMNEY FOUNDATION

Guidelines for Reverse Auction – 2021

Doc. No. AA:SSP:RA:05
Dated: 08.03.2021

1.0 Scope

This document describes the guidelines to be followed by BHEL for conducting Reverse Auction (RA) for procurement of material/ works/ services. The RA shall follow the philosophy of English Reverse (No ties).

English Reverse (No ties) is a type of auction where the starting price and bid decrement are announced before start of online reverse auction. The interested bidders can thereupon start bidding in an iterative process wherein the lowest bidder at any given moment can be displaced by an even lower bid of a competing bidder, within a given time frame. The bidding is with reference to the current lowest bid in the reverse auction. All bidders will see the current lowest quoted price and their rank. The term 'No ties' is used since more than one bidder cannot give an identical price, at a given instant, during the reverse auction. In other words, there shall never be a tie in the bids.

3.0 Upfront declaration in NIT

Decision to go for RA would be taken before floating of the tender. In case it is decided to go for RA, same shall be declared upfront in NIT by inserting the following **clause**:

"BHEL shall be resorting to Reverse Auction (RA) (Guidelines as available on www.bhel.com) for this tender. RA shall be conducted among the techno-commercially qualified bidders.

Price bids of all techno-commercially qualified bidders shall be opened and same shall be considered for RA. In case any bidder(s) do(es) not participate in online Reverse Auction, their sealed envelope price bid along with applicable loading, if any, shall be considered for ranking."

6.0 Business rules for RA

Model Annexure-I is attached.

7.0 Role of Service Provider

- Acknowledge the receipt of mandate from BHEL.
- Contact the bidders, provide business rules and train them, as required.
- Get the process compliance form signed by all the participating bidders before RA event.

Guidelines for Reverse Auction – 2021

Doc. No. AA:SSP:RA:05
Dated: 08.03.2021

- Conduct the event as per the contract and business rules.
- Submit the Login Reports, Results, History sheet and authorized final bid from the bidders.
- To obtain price breakup from successful bidder and submit the same to BHEL.

10.0 Reverse Auction Process

10.1 Reverse Auction will be conducted if two or more bidders are techno-commercially qualified. In case of two or three qualified bidders, there shall be no elimination of H1 bidder (whose quote is highest in sealed envelope price bid). In case of four qualified bidders, the H1 bidder shall be eliminated whereas in case of five qualified bidders, H1 & H2 bidders shall be eliminated. However, in case of six or more qualified bidders are available, RA would be conducted amongst first 50% of the bidders arranged in the order of prices from lowest to highest. Number of bidders eligible for participating in RA would be rounded off to next higher integer value if number of qualified bidders is odd (e.g. if 7 bids are qualified, then RA will be conducted amongst lowest four bidders). However, there will be no elimination of qualified bidders who are MSE or qualifying under PPP-MII, Order 2017, irrespective of the number of bidders qualifying techno-commercially.

In case of multiple H1 bidders, all H1 bidders (excluding MSEs and bidders qualifying under PPP-MII, Order 2017) shall be removed provided minimum two bidders remain in fray, else no H1 removal.

10.2 During RA, all bidders will see their rank and current L1 price on the screen. Once the RA is done, the ranking status would be based on the last quoted price of the bidder(s) irrespective of the quote received in RA or sealed envelope price bid.

10.3 No bidder shall be allowed to lower its bid below the current L1 by more than 5 decrements at one go.

11.0 Processing of case after RA

11.2 In case of splitting requirement, bidders who were removed from participation in RA may also be considered for counter offer if the pre-stated (NIT) numbers of suppliers do not accept the counter offer.

Guidelines for Reverse Auction – 2021

Doc. No. AA:SSP:RA:05
Dated: 08.03.2021

13.0 Others

- 13.2 In case of enquiry through e-Procurement, the sealed electronic price bid (e-bid) is to be treated as sealed envelope price bid.
- 13.3 BHEL will inform bidders the details of service provider who will provide business rules, all necessary training and assistance before commencement of online bidding.
- 13.4 Bidders will be advised to read the 'Business Rules' indicating details of RA event carefully, before reverse auction event.

---XXX---

ABRIDGED VERSION

Guidelines for Reverse Auction – 2021

Doc. No. AA:SSP:RA:05

Dated: 08.03.2021

Business Rules for Reverse Auction

Annexure – I

This has reference to tender no **{tender number....date...}**. BHEL shall finalise the Rates for the supply of **{item name}** through Reverse Auction mode. BHEL has made arrangement with M/s. **{Service provider}**, who shall be BHEL's authorized service provider for the same. Bidders should go through the instructions given below and submit acceptance of the same.

The technical & commercial terms are as per (a) BHEL Tender Enq. No. {...} dated {...}, (b) Bidders' technical & commercial bid (in case of two part bid) and (c) subsequent correspondences between BHEL and the bidders, if any.

1. Procedure of Reverse Auctioning

- i. Price bids of all techno-commercially qualified bidders shall be opened.
- ii. **Reverse Auction:** The 'bid decrement' will be decided by BHEL.
- iv. Bidders by offering a minimum bid decrement or the multiples thereof can displace a standing lowest bid and become "L1" and this continues as an iterative process. However, no bidder shall be allowed to lower its bid below the current L1 by more than 5 decrements at one go.
- v. After the completion of the reverse auction, the Closing Price shall be available for further processing.
- vi. Wherever the evaluation is done on total cost basis, after Reverse Auction, prices of individual line items shall be reduced on pro-rata basis.

2. Schedule for reverse auction: The Reverse Auction is tentatively scheduled on **{date}**: **{start time}**: **{Close Time}**: **}**.

3. Auction extension time: If a bidder places a bid in the last {...} minutes of closing of the Reverse Auction and if that bid gets accepted, then the auction's duration shall get extended automatically for another {...} minutes, for the entire auction (i.e. for all the items in the auction), from the time that bid comes in. Please note that the auto-extension will take place only if a bid comes in those last {...} minutes and if that bid gets accepted as the lowest bid. If the bid does not get accepted as the lowest bid, the auto-extension will not take place even if that bid might have come in the last {...}

Guidelines for Reverse Auction – 2021

Doc. No. AA:SSP:RA:05

Dated: 08.03.2021

Business Rules for Reverse Auction

Annexure – I

minutes. In case, there is no bid in the last {...} minutes of closing of Reverse Auction, the auction shall get closed automatically without any extension. However, bidders are advised not to wait till the last minute or last few seconds to enter their bid during the auto-extension period to avoid complications related with internet connectivity, network problems, system crash down, power failure, etc.

The above process will continue till completion of Reverse Auction.

Complaints/ Grievances, if any, regarding denial of service or any related issue should be given in writing thru e-mail/ fax to M/s. {Service provider} with a copy to BHEL within 15 minutes prior to initial closing time of Reverse Auction.

4. **Bid price:** The Bidder has to quote the {...} Price inclusive of Packing & Forwarding charges, all the routine & type tests as per tender scope, taxes, duties, freight and insurance as specified in tender document, including loading (if indicated by BHEL due to deviations in technical/ commercial terms) for the Items specified. Details are as shown in Excel Sheet for calculation of total cost to BHEL (To be specified by Unit as per NIT conditions).
5. **Bidding currency and unit of measurement:** Bidding will be conducted in *Indian Rupees per Unit* of the material as per the specifications {...}

In case of foreign currency bids, exchange rate (TT selling rate of State Bank of India) as on scheduled date of tender opening (Part-I bid) shall be considered for conversion in Indian Rupees. If the relevant day happens to be a Bank holiday, then the forex rate as on the previous bank (SBI) working day shall be taken.
6. **Validity of bids:** Price shall be valid for {... days} from the date of reverse auction. These shall not be subjected to any change whatsoever.
7. **Lowest bid of a bidder:** In case the bidder submits more than one bid, the lowest bid at the end of Reverse Auction will be considered as the bidder's final offer to execute the work.
8. Unique user IDs shall be used by bidders during bidding process. All bids

Guidelines for Reverse Auction – 2021

Doc. No. AA:SSP:RA:05

Dated: 08.03.2021

Business Rules for Reverse Auction

Annexure – I

made from the Login ID given to the bidders will be deemed to have been made by the bidders/ bidders' company.

- 9. Post auction procedure:** BHEL will proceed with the Lowest Bid in the Reverse Auction for further processing.
- 11.** Reverse auction shall be conducted by BHEL (through M/s {Service Provider}), on pre-specified date, while the bidders shall be quoting from their own offices/ place of their choice. Internet connectivity shall have to be ensured by bidders themselves.

During the RA process if a bidder is not able to bid and requests for extension of time by FAX/ email/ phone then time extension of additional 15 minutes will be given by the service provider provided such requests come before 5 minutes of auction closing time. However, only one such request per bidder can be entertained.

In order to ward-off contingent situation of connectivity failure bidders are requested to make all the necessary arrangements/ alternatives whatever required so that they are able to circumvent such situation and still be able to participate in the reverse auction successfully. Failure of power or loss of connectivity at the premises of bidders during the Reverse auction cannot be the cause for not participating in the reverse auction. On account of this, the time for the auction cannot be extended and neither BHEL nor M/s. {Service provider} is responsible for such eventualities.

- 12.** Proxy bids: Proxy bidding feature is a pro-bidder feature to safe guard the bidder's interest of any internet failure or to avoid last minute rush. The proxy feature allows bidders to place an automated bid in the system directly in an auction and bid without having to enter a new amount each time a competing bidder submits a new offer. The bid amount that a bidder enters is the minimum that the bidder is willing to offer. Here the software bids on behalf of the bidder. This obviates the need for the bidder participating in the bidding process until the proxy bid amount is decrementally reached by other bidders. When proxy bid amount is reached, the bidder (who has submitted the proxy bid) has an option to start participating in the bidding process.

The proxy amount is the minimum amount that the bidder is willing to offer.

Guidelines for Reverse Auction – 2021

Doc. No. AA:SSP:RA:05

Dated: 08.03.2021

Business Rules for Reverse Auction

Annexure – I

During the course of bidding, the bidder cannot delete or change the amount of a proxy bid.

Bids are submitted in decrements (decreasing bid amounts). The application automates proxy bidding by processing proxy bids automatically, according to the decrement that the auction originator originally established when creating the auction, submitting offers to the next bid decrement each time a competing bidder bids, regardless of the fact whether the competing bids are submitted as proxy or standard bids. However, it may please be noted that if a manual bid and proxy bid are submitted at the same instant manual bid will be recognized as the L1 at that instant.

In case of more than one proxy bid, the system shall bid till it crosses the threshold value of 'each lowest proxy bid' and thereafter allow the competition to decide the final L1 price.

Proxy bids are fed into the system directly by the respective bidders. As such this information is privy only to the respective bidder(s).

13. Bidders are advised to get fully trained and clear all their doubts such as refreshing of Screen, quantity being auctioned, tender value being auctioned etc from M/s {Service provider}.
14. M/s. {Service provider}, shall arrange to demonstrate/ train the bidder or bidder's nominated person(s), without any cost to bidders. M/s. {Service provider}, shall also explain the bidders, all the business rules related to the Reverse Auction. Bidders are required to submit their acceptance to the terms/ conditions/ modalities before participating in the Reverse Auction in the process compliance form as enclosed. Without this, the bidder will not be eligible to participate in the event.
15. Successful bidder shall be required to submit the final prices (L1) in prescribed format (Annexure – VI) for price breakup, quoted during the Reverse Auction, duly signed and stamped as token of acceptance without any new condition (other than those already agreed to before start of auction), after the completion of auction to M/s. {Service provider} besides BHEL within two working days of Auction without fail.
16. Any variation between the final bid value and that in the confirmatory

Guidelines for Reverse Auction – 2021

Doc. No. AA:SSP:RA:05
Dated: 08.03.2021

Business Rules for Reverse Auction

Annexure – I

signed price breakup document will be considered as tampering the tender process and will invite action by BHEL as per extant guidelines for suspension of business dealings (as available on www.bhel.com).

17. Bidders' bid will be taken as an offer to execute the work/ supplies the item as per enquiry no. {...} dt. {...}. Bids once made by the bidder, cannot be cancelled/ withdrawn and bidder shall be bound to execute the work as mentioned above at bidder's final bid price. Should bidder back out and not execute the contract as per the rates quoted, BHEL shall take action as per extant guidelines for suspension of business dealings (as available on www.bhel.com).
18. Bidders shall be able to view the following on their screen along with the necessary fields during Reverse Auction:
 - a. Leading (Running Lowest) Bid in the Auction (only total price of package)
 - b. Bid Placed by the bidder
 - c. Start Price
 - d. Decrement value
 - e. Rank of their own bid during bidding as well as at the close of auction.
19. BHEL's decision on award of contract shall be final and binding on all the Bidders.
20. BHEL reserves the right to extend, reschedule or cancel the Reverse Auction process at any time, before ordering, without assigning any reason, with intimation to bidders.
21. BHEL shall not have any liability to bidders for any interruption or delay in access to the site irrespective of the cause. In such cases, the decision of BHEL shall be binding on the bidders.
22. Other terms and conditions shall be as per bidder's techno-commercial offers and other correspondences, if any, till date.
23. If there is any clash between this business document and the FAQ available, if any, in the website of M/s. {Service provider}, the terms & conditions given in this business document will supersede the information contained in the FAQs. Any changes made by BHEL/ service provider (due to unforeseen

Guidelines for Reverse Auction – 2021

Doc. No. AA:SSP:RA:05
Dated: 08.03.2021

Business Rules for Reverse Auction

Annexure – I

contingencies) after the first posting shall be deemed to have been accepted if the bidder continues to access the portal after that time.

- 24.** Bidder shall not divulge either his Bids or any other exclusive details of BHEL to any other party. If the Bidder or any of his representatives are found to be involved in Price manipulation/ cartel formation of any kind, directly or indirectly by communicating with other bidders, action as per extant BHEL guidelines for suspension of business dealings (as available on www.bhel.com), shall be initiated by BHEL.

ABRIDGED VERSION



GENERAL CONDITIONS OF CONTRACT

**SOLAR BUSINESS DIVISION
BHARAT HEAVY ELECTRICALS LIMITED**
(A Govt. of India Undertaking)
PROF. CNR RAO CIRCLE, IISc POST
MALLESHWARAM
BENGALURU - 560012



CONTENTS

Chapter-1

- 1. General Instructions to Tenderers*
 - 1.1. Dispatch Instructions*
 - 1.2. Submission of Tenders*
 - 1.3. Language*
 - 1.4. Price Discrepancy*
 - 1.5. Evaluation of Bids*
 - 1.6. Data to be enclosed*
 - 1.7. Authorisation and Attestation*
 - 1.8. Earnest Money Deposit*
 - 1.9. Security Deposit*
 - 1.10. Return of Security Deposit*
 - 1.11. Bank Guarantee*
 - 1.12. Validity of offer*
 - 1.13. Execution of Contract Agreement*
 - 1.14. Rejection of Tender and other Conditions*
 - 1.15. BHEL Fraud Prevention Policy*



2. Chapter-2

2.1. Definitions

2.2. Law Governing Contract and Court Jurisdiction

2.3. Issue of Notice

2.4. Use of land

2.5. Commencement of Work

2.6. Measurement of Work and Mode of Payment

2.7. Rights of BHEL

2.8. Responsibilities of Contractor in respect of Local Laws, Employment of Workers etc

2.9. Progress Monitoring, Monthly Review and Performance Evaluation

2.10. Time of Completion

2.11. Extension of Time for Completion

2.12. Over Run Compensation

2.13. Quantity Variation

2.14. Extra Works

2.15. Supplementary Items

2.16. Strikes & Lockout

2.17. Force Majeure

2.18. Arbitration and Reconciliation

2.19. Payments

2.20. Performance Guarantee for Workmanship

2.21. Closing of Contracts

2.22. Reverse Auction

2.23. Suspension of Business Dealings

2.24. Other Issues

CHAPTER -1

1. GENERAL INSTRUCTION TO TENDERERS

1.1. DESPATCH INSTRUCTION

i) The General Conditions of Contract form part of the Tender specifications. All pages of the tender documents shall be duly signed, stamped and submitted along with the offer in token of complete acceptance thereof. The information furnished shall be complete by itself. The tenderer is required to furnish all the details and other documents as required in the following pages

ii) Tenderers are advised to study all the tender documents carefully. Any submission of tender by the tenderer shall be deemed to have been done after careful study and examination of the tender documents and with the full understanding of the implications thereof. Should the tenderers have any doubt about the meaning of any portion of the Tender Specification or find discrepancies or omissions in the drawings or the tender documents issued are incomplete or shall require clarification on any aspects, the scope of work etc., he shall contact the authority inviting the tender well in time (so as not to affect last date of submission) for clarification before the submission of the tender. Tenderer's request for clarifications shall be with reference to Sections and Clause numbers given in the tender documents. The tender specifications and terms and conditions shall be deemed to have been accepted by the tenderer in the offer. Pre requirements and conditions shall be liable for rejection.

iii) Integrity pact (IP): If NIT calls for Integrity Pact, the same shall be duly signed & stamped by the authorised signatory & submitted along with tender document.

1.2. SUBMISSION OF TENDERS

1.2.1 The tenderers must submit their tenders as per instructions in the NIT

1.2.2 BHEL takes no responsibility for delay, loss or non-receipt of tenders sent by post/courier. The tenders received after the specified time of their submission are treated as 'Late Tenders' and shall not be considered under any circumstances. Offers received by Fax/Email/Internet shall be considered as per terms of NIT.

1.2.3 Tenders shall be opened by authorised Officer of BHEL at his office at the time and date as specified in the NIT, in the presence of such of those tenderers or their authorised representatives who may be present

1.2.4 Tenderers whose bids are found techno commercially qualified shall be informed the date and time of opening of the Price Bids and such Tenderers may depute their representatives to witness the opening of the price bids. BHEL's decision in this regard shall be final and binding.

1.2.5 Before submission of Offer, the tenderers are advised to inspect the site of work and the environments and be well acquainted with the actual working and other prevalent conditions, facilities available, position of material and labour, means of transport and access to Site, accommodation, etc. No claim will be entertained later on the grounds of lack of knowledge of any of these conditions.

1.3. **LANGUAGE**

1.3.1 The tenderer shall quote the rates in English language and international numerals. These rates shall be entered in figures as well as in words. For the purpose of the tenders, the metric system of units shall be used.

1.3.2 All entries in the tender shall either be typed or written legibly in ink. Erasing and overwriting is not permitted and may render such tenders liable for rejection. All cancellations and insertions shall be duly attested by the tenderer.

1.4 **PRICE DISCREPANCY:**

1.4.1 Conventional (Manual) Price Bid opening:

i) If, in the price structure quoted for the required goods/services/works, there is discrepancy between the unit price and the total price (which is obtained by multiplying the unit price by the quantity), the unit price shall prevail and the total price corrected accordingly, unless in the opinion of BHEL there is obvious misplacement of decimal point in the unit price, in which case the total price as quoted shall govern and the unit price corrected accordingly

ii) If there is an error in a total corresponding to the addition or subtraction of subtotals, the subtotals shall prevail and the total shall be corrected;

iii) If there is a discrepancy between words and figures, the amount in words shall prevail, unless the amount expressed in words is related to an arithmetic error, in which case the amount in figures shall prevail subject of (i) and (ii) above.

iv) If there is such discrepancy in an offer, the same shall be conveyed to the bidder with target date up to which the bidder has to send his acceptance on the above lines and if the bidder does not agree to the decision of BHEL, the bid is liable to be ignored.

v) In case of lump sum price, if there is any difference between the amount in figures and in words, the amount quoted by the bidder in words shall be taken as correct.



vi) *In case of omission in quoting any rate for one or more items, the evaluation shall be done considering the highest quoted rate obtained against the respective items by other tenderers for the subject tender. If the tenderer becomes L-1, the notional rates for the omission items shall be the lowest rates quoted for the respective items by the other tenderers against the respective omission items for the subject job and the 'Total quoted price (loaded for omissions)' shall be arrived at. However, the overall price remaining the same as quoted originally, the rates for all the items in the 'Total quoted price (loaded for omissions)' shall be reduced item wise in proportion to the ratio of 'Original' total price and the 'Total quoted price (loaded for omissions)'.*

1.4.2 Reverse Auction: In case of Reverse Auction, the successful bidder shall undertake to execute the work as per overall price offered by him during the Reverse Auction process. In case of omission of rates, the procedure shall be as per 'Guidelines for Reverse Auction' enclosed.

i) Offers from tenderers who are under suspension (banned) by any Unit/Region/Division of BHEL shall not be considered. ii) Offers from tenderers who do not comply with the latest guidelines of Ministry/ Commissions of Govt of India shall not be considered.

1.5. EVALUATION OF BIDS

i) Technical Bids submitted by the tenderer will be opened first and evaluated for fulfilling the Pre-Qualification criteria and other conditions in NIT/Tender documents, based on documentary evidences submitted along with the offer, BHEL reserves the right to ask for proofs/documents, clarification in relation to Technical/commercial data during tender evaluation

ii) Price Bids of shortlisted bidders shall only be opened either through the conventional price bid opening or through electronic Reverse Auction, at the discretion of BHEL

iii) Price Bids of unqualified bidders shall not be opened. Reasons for rejection shall be intimated to the vendor before the opening of Price bid.

1.6. DATA TO BE ENCLOSED

The following information in full shall be furnished by the tenderer. Non-submission of this information may lead to rejection of the offer.

i) INCOME TAX PERMANENT ACCOUNT NUMBER, GSTIN, SAC, HSN Certified copies of PAN, GSTIN shall be furnished along with tender. The names, addresses and contact information of the Directors/Partners shall be furnished along with the offer.

ii) An attested copy of the Power of Attorney, in case the tender is signed by an individual other than the sole proprietor.



iii) *IN CASE OF INDIVIDUAL TENDERER:*

His / her full name, address, PAN, GSTIN and place & nature of business to be furnished. iv)

IN CASE OF PARTNERSHIP FIRM

The names of all the partners and their addresses, a copy of the partnership deed/instrument of partnership shall be enclosed.

v) *IN CASE OF COMPANIES:*

Date and place of registration including date of commencement certificate in case of Public Companies (certified copies of Memorandum and articles of Association are also to be furnished). Nature of business carried on by the Company and the provisions of the Memorandum relating thereof.

1.7. AUTHORISATION AND ATTESTATION

Tenders shall be signed by a person duly authorised/empowered to do so. An attested copy of the Power of Attorney, in case the tender is signed by an individual other than the sole proprietor shall be submitted along with the tenders

1.8. EARNEST MONEY DEPOSIT

1.8.1 Every tender must be accompanied by the prescribed amount of Earnest Money Deposit (EMD) in the manner described herein.

The EMD may be accepted only in the following forms:

- (i) Electronic Fund Transfer credited in BHEL account (before tender opening)*
- (ii) Banker's cheque/ Pay order/ Demand draft, in favour of BHEL (along with offer) In case total EMD amount is more than Rs.20 Lakh, the amount in excess of Rs.20 lakh maybe accepted in the form of Bank Guarantee from scheduled bank. The Bank Guarantee in such cases shall be valid for at-least six months.*
- (iii) Through SBI collect/RTGS (before tender opening)*
- (iv) No other form of EMD remittance shall be acceptable to BHEL*

1.8.2 EMD by the bidder will be forfeited as per Tender Documents if

- i) After opening the tender and within the offer validity period, the tenderer revokes his/her tender or makes any modification in his tender which is not acceptable to BHEL.*
- ii) The Contractor fails to deposit the required Security deposit or commence the work within the period as per LOI/ Contract.*
- iii) EMD by the tenderer shall be withheld in case any action on the tenderer is envisaged in derailing the tender process by unlawful means.*

1.8.3 EMD shall not carry any interest.



1.8.4 In the case of unsuccessful bidders, the Earnest Money will be refunded to them within a reasonable time after acceptance of award by successful tenderer.

1.8.5 EMD of successful tenderer will be converted as part of Security Deposit

1.9. **SECURITY DEPOSIT**

"Bidder agrees to submit performance security required for execution of the contract within the time period mentioned. In case of delay in submission of performance security, enhanced performance security which would include interest (SB/ rate + 6%) for the delayed period, shall be submitted by the bidder. Further, if performance security is not submitted till such time the first bill becomes due, the amount of performance security due shall be recovered as per terms defined in NIT I contract, from the bills along with due interest "

The total amount of Security Deposit will be 5% of the contract value (including all applicable taxes) EMD of the successful tenderer shall be converted and adjusted towards the required amount of Security Deposit.

1.9.1 Modes of Security deposit:

The balance amount to make up the required Security Deposit of 5% of the contract value may be accepted in the following forms:

i) Cash (as permissible under the extant Income Tax Act) ii) Local cheques of Scheduled Banks (subject to realization)/ Pay Order/ Demand Draft/ Electronic Fund Transfer in favour of BHEL

iii) Bank Guarantee from Scheduled Banks/ Public Financial Institutions as defined in the Companies Act. The Bank Guarantee format should have the approval of BHEL iv) Fixed Deposit Receipt issued by Scheduled Banks/ Public Financial Institutions as defined in the Companies Act (FDR should be in the name of the Contractor, a/c BHEL)

v) Securities available from Indian Post offices such as National Savings Certificates, Kisan Vikas Patras etc. (held in the name of Contractor furnishing the security and duly endorsed/ hypothecated/ pledged, as applicable, in favour of BHEL) (Note: BHEL will not be liable or responsible in any manner for the collection of interest or renewal of the documents or in any other matter connected therewith) vi) 50% of the required Security Deposit, including the EMD, should be paid before start of the work. Balance of the Security Deposit can be collected by deducting 10% of the gross amount progressively from each of the running bills of the Contractor till the total amount of the required Security Deposit is collected. If the value of work done at any time exceeds the contract value, the amount of Security Deposit shall be correspondingly enhanced and the additional Security Deposit shall be immediately deposited by the Contractor or recovered from payment/s due to the Contractor. Security Deposit shall be released to the Contractor upon fulfilment of contractual obligations as per terms of the contract.

1.9.2 The Security Deposit shall not carry any interest.



1.9.3 The validity of Bank Guarantees towards Security Deposit shall be initially up to the completion period as stipulated in the Letter of Intent/Award (plus maintenance period if applicable), and 03 months claim period. The same shall be kept valid by proper renewal till the acceptance of Final Bills of the Contractor, by BHEL

1.9.4 BHEL reserves the right of forfeiture of Security Deposit in addition to other claims and penalties in the event of the Contractor's failure to fulfil any of the contractual obligations or in the event of termination of contract as per terms and conditions of contract. BHEL reserves the right to set off the Security Deposit against any claims of other contracts with BHEL.

1.10. **REFUND OF SECURITY DEPOSIT**

50% of the security deposit may be refunded on completion of the work after payment of the final bill and the balance 50% of the security deposit is refunded only after the expiry of the maintenance period from date of completion of work as stipulated in the contract concerned.

1.10.1 DEFECTS LIABILITY PERIOD:

The contractor shall be responsible to make good and remedy at his own expenses within such period as may be stipulated by the Engineer-in-charge, any defect which may develop or may be noticed before the expiry of the maintenance period of six months or as stipulated in NIT hereto from the certified date of completion and intimation of which has been sent to the contractor within seven days of the expiry of the said period by a letter sent by hand delivery or by registered post or Email. If contractor fails to attend to the above, defect will be rectified at contractor's risk & cost and same will be deducted from the security deposit/payable amounts available with BHEL.

1.11. **BANK GUARANTEES**

Where ever Bank Guarantees are to be furnished/submitted by the contractor, the following shall be complied with

i) Bank Guarantees shall be from Scheduled Banks / Public Financial Institutions as defined in the Companies Act. ii) The Bank Guarantees shall be as per prescribed BHEL formats.

iii) It is the responsibility of the bidder to get the Bank Guarantees revalidated/extended for the required period (subject to a minimum period of six months), as per the advice of BHEL. BHEL shall not be liable for issue of any reminders regarding expiry of the Bank Guarantees.

iv) In case extension/further extensions of any Bank Guarantees are not required, the bidders shall ensure that the same is explicitly endorsed by BHEL



- v) *In case the Bank Guarantees are not extended before the expiry date, BHEL reserves the right to invoke the same by informing the concerned Bank in writing, without any advance notice/communication to the concerned bidder.*
- vi) *Bidders to note that any corrections to Bank Guarantees shall be done by the issuing Bank, only through an amendment in an appropriate non judicial stamp paper.*
- vii) *The Original Bank Guarantee shall be sent directly by the Bank to BHEL under Registered Post (Acknowledgement Due).*

1.12. VALIDITY OF OFFER

The rates in the Tender shall be kept open for acceptance for a minimum period of Ninety (90) DAYS from latest due date of offer submission (including extension, if any). In case BHEL calls for negotiations, such negotiations shall not amount to cancellation or withdrawal of the original offer which shall be binding on the tenderers.

1.13 EXECUTION OF CONTRACT AGREEMENT

The successful tenderer's responsibility under this contract commences from the date of issue of the Letter of Intent by BHEL. The Tenderer shall submit an unqualified acceptance to the Letter of Intent/Award within the period stipulated therein.

The successful tenderer shall be required to execute an agreement in the prescribed form, with BHEL, within fifteen days (15 days) after the acceptance of the Letter of Intent/Award, and in any case before releasing the first running bill. The contract agreement shall be signed by a person duly authorized/empowered by the tenderer. The expenses for preparation of agreement document shall be borne by Tenderer.

1.14. REJECTION OF TENDER AND OTHER CONDITIONS

1.14.1 The acceptance of tender will rest with BHEL which does not bind itself to accept the lowest tender or any tender and reserves to itself full rights for the following without assigning any reasons whatsoever: -

- a. To reject any or all of the tenders.*
- b. To split up the work amongst two or more tenderers as per NIT*
- c. To award the work in part if specified in NIT*
- d. In case of either of the contingencies stated in (b) and (c) above, the time for completion as stipulated in the tender shall be applicable.*



1.14.2 Conditional tenders, unsolicited tenders, tenders which are incomplete or not in the form specified or defective or have been materially altered or not in accordance with the tender conditions, specifications etc., are liable to be rejected.

1.14.3 Tenders are liable to be rejected in case of unsatisfactory performance of the tenderer with BHEL, or tenderer under suspension (hold/banning /delisted) by any unit / region / division of BHEL or tenderers who do not comply with the latest guidelines of Ministry/Commissions of Govt of India. BHEL reserves the right to reject a bidder in case it is observed that they are overloaded and may not be in a position to execute this job. The decision of BHEL will be final in this regard.

1.14.4 If a tenderer who is a proprietor expires after the submission of his tender or after the acceptance of his tender, BHEL may at their discretion, cancel such tender. If a partner of a firm expires after the submission of tender or after the acceptance of the tender, BHEL may then cancel such tender at their discretion, unless the firm retains its character.

1.14.5 BHEL will not be bound by any Power of Attorney granted by changes in the composition of the firm made subsequent to the execution of the contract. They may, however, recognize such power of Attorney and changes after obtaining proper legal advice, the cost of which will be chargeable to the contractor concerned.

1.14.6 If the tenderer deliberately gives wrong information in his tender, BHEL reserves the right to reject such tender at any stage or to cancel the contract if awarded and forfeit the Earnest Money/Security Deposit/any other money due.

1.14.7 Canvassing in any form in connection with the tenders submitted by the Tenderer shall make his offer liable to rejection.

1.14.8 In case the Proprietor, Partner or Director of the Company/Firm submitting the Tender, has any relative or relation employed in BHEL, the authority inviting the Tender shall be informed, along with the Offer. Failing to do so, BHEL may, at its sole discretion, reject the tender or cancel the contract and forfeit the Earnest Money/Security Deposit.

1.14.9 The successful tenderer should not sub-contract part or complete work detailed in the tender specification undertaken by him without written permission of BHEL's Construction Manager/Site Incharge. The tenderer is solely responsible to BHEL for the work awarded to him.

1.14.10 The Tender submitted by a techno commercially qualified tenderer shall become the property of BHEL who shall be under no obligation to return the same to the bidder. However unopened price bids and late tenders shall be returned to the bidders after finalization of contract.

1.14.11 Unsolicited discount received after the due date and time of Bid Submission shall not be considered for evaluation. However, if the party who has submitted the unsolicited



discount/rebate becomes the L-I party, then the awarded price i.e contract value shall be worked out after considering the discount so offered.

1.14.12 BHEL shall not be liable for any expenses incurred by the bidder in the preparation of the tender irrespective of whether the tender is accepted or not.

1.15 BHEL Fraud Prevention Policy:

The bidder along with its associate/ collaborators/sub-contractors/ Sub-Vendors/ Consultants/service providers shall strictly adhere to BHEL Fraud Prevention Policy displayed on BHEL website <http://www.bhel.com> and shall immediately bring to the notice of BHEL Management about any fraud or suspected fraud as soon as it comes to their notice. Fraud prevention policy and list of Nodal officers shall be hosted on BHEL website, vendor portals of Units/Regions Internet.

CHAPTER-2

2.1 DEFINITION: The following terms shall have the meaning hereby assigned to them except where the context otherwise requires

- i) BHEL shall mean Bharat Heavy Electricals Limited, a company registered under Companies Act 1956, with its Registered Office at BHEL HOUSE, SIRI FORT, NEW DELHI – 110 049, or its Authorised Officers or its Site Engineers or other employees authorised to deal with any matters with which these persons are concerned on its behalf.
- ii) "EXECUTIVE DIRECTOR" or 'GROUP GENERAL MANAGER' or "GENERAL MANAGER (Incharge)" or "GENERAL MANAGER" shall mean the Officer in SOLAR BUSINESS DIVISION, Prof. CNR Rao Circle, IISc Post, Malleshwaram, BENGALURU - 560012
- iii) "COMPETENT AUTHORITY" shall mean Executive Director or Group General Manager or General Manager (In-charge) or General Manager or BHEL Officers who are empowered to act on behalf of the Executive Director or General Manager (In-charge) or General Manager of BHEL.
- iv) "ENGINEER" or "ENGINEER IN CHARGE" shall mean an Officer of BHEL as may be duly appointed and authorized by BHEL to act as "Engineer" on his behalf for the purpose of the Contract, to perform the duty set forth in this General Conditions of Contract and other Contract documents. The term also includes 'CONSTRUCTION MANAGER' or 'SITE INCHARGE' as well as Officers



- v) *"SITE" shall mean the places or place at which the plants/equipment are to be erected and services are to be performed as per the specification of this Tender.*
- vi) *"CLIENT OF BHEL" or "CUSTOMER" shall mean the project authorities with whom BHEL has entered into a contract for supply of equipment or provision of services.*
- vii) *"CONTRACTOR" shall mean the successful Bidder/Tenderer who is awarded the Contract and shall include the Contractor's successors, heirs, executors, administrators and permitted assigns.*
- viii) *"CONTRACT" or "CONTRACT DOCUMENT" shall mean and include the Work Order, Contract Agreement, the accepted appendices of Rates, Schedules, Quantities if any, General Conditions of Contract, Special Conditions of Contract, Instructions to the Tenderers, Drawings, Technical Specifications, the Special Specifications if any, the Tender documents, subsequent amendments mutually agreed upon and the Letter of Intent/Acceptance issued by BHEL. Any conditions or terms stipulated by the contractor in the tender documents or subsequent letters shall not form part of the contract unless, specifically accepted in writing by BHEL in the Letter of Intent/Award and incorporated in the agreement.*
- ix) *"GENERAL CONDITIONS OF CONTRACT" shall mean the 'Instructions to Tenderers' and 'General Conditions of Contract' pertaining to the work for which above tenders have been called for.*
- x) *"TENDER SPECIFICATION" or "TENDER" or "TENDER DOCUMENTS" shall mean General Conditions, Common Conditions, Special Conditions, Price Bid, Rate Schedule, Technical Specifications, Appendices, Annexures, Corrigendum's, Amendments, Forms, procedures, Site information, etc and drawings/documents pertaining to the work for which the tenderers are required to submit their offers. Individual specification number will be assigned to each Tender Specification.*
- xi) *"LETTER OF INTENT" shall mean the intimation by a Post/Fax/email to the tenderer that the tender has been accepted in accordance with provisions contained in the letter. The responsibility of the contractor commences from the date of issue of this letter and all terms and conditions of the contract are applicable from this date.*
- xii) *"COMPLETION TIME" shall mean the period by 'date/month' specified in the 'Letter of Intent/Award' or date mutually agreed upon for handing over of the intended scope of work, the erected equipment/plant which are found acceptable by the Engineer, being of required standard and conforming to the specifications of the Contract.*
- xiii) *"PLANT" shall mean and connote the entire assembly of the plant and equipment's covered by the contract.*



- xiv) *"EQUIPMENT" shall mean equipment, machineries, materials, structural, electrical and other components of the plant covered by the contract.*
- xv) *"TESTS" shall mean and include such test or tests to be carried out on the part of the contractor as are prescribed in the contract or considered necessary by BHEL, in order to ascertain the quality, workmanship, performance and efficiency of the contractor or part thereof.*
- xvi) *"APPROVED", "DIRECTED" or "INSTRUCTED" shall mean approved, directed or instructed by BHEL.*
- xvii) *"WORK or CONTRACT WORK" shall mean and include supply of all categories of labour, specified consumables, tools and tackles and Plants required for complete and satisfactory site transportation, handling, stacking, storing, erecting, testing and commissioning of the equipment's to the entire satisfaction of BHEL.*
- xviii) *"SINGULAR AND PLURALS ETC" words carrying singular number shall also include plural and vice versa, where the context so requires. Words imparting the masculine Gender shall be taken to include the feminine Gender and words imparting persons shall include any Company or Associations or Body of Individuals, whether incorporated or not.*
- xix) *"HEADING" – The heading in these General Conditions are solely for the purpose of facilitating reference and shall not be deemed to be part thereof or be taken as instructions thereof or of the contract.*
- xx) *"MONTH" shall mean calendar month unless otherwise specified in the Tender.*
- xxi) *Day' or 'Days' unless herein otherwise expressly defined shall mean calendar day or days of twenty-four (24) hours each. A week shall mean continuous period of seven (7) days.*
- xxii) *"COMMISSIONING" shall mean the synchronization testing and achieving functional operation of the Equipment with associated system after all initial adjustments, trials, cleaning, re-assembly required at site if any, have been completed and Equipment with associated system is ready for taking into service.*
- xxiii) *"WRITING" shall include any manuscript type written or hand written or printed statement or electronically transmitted messages, under the signature or seal or transmittal of BHEL.*
- xxiv) *"TEMPORARY WORK" shall mean all temporary works for every kind required in or for the execution, completion, maintenance of the work.*
- xxv) *'CONTRACT PRICE' or 'CONTRACT VALUE' shall mean the sum including applicable taxes mentioned in the LOI/LOA/Contract Agreement subject to such additions thereto or deductions there from as may be made under provisions hereinafter contained*



xxvi) "COMMENCEMENT DATE" or "START DATE" shall mean the commencement/start of work at Site as per terms defined in the Tender

xxvii) "SHORT CLOSING" or "FORE CLOSING" of Contract shall mean the premature closing of Contract, for reasons not attributable to the contractor and mutually agreed between BHEL and the contractor

xxviii) "TERMINATION" of Contract shall mean the premature closing of contract due to reasons as mentioned in the contract

2.2 LAW GOVERNING THE CONTRACT AND COURT JURISDICTION

The contract shall be governed by the Law for the time being in force in the Republic of India. The Civil Court having original Civil Jurisdiction at Bengaluru, shall alone have exclusive jurisdiction in regard to all claims in respect of the Contract. No other Civil Court shall have jurisdiction in case of any dispute, under this contract

2.3 ISSUE OF NOTICE

2.3.1 Service of notice on contractor: Any notice to be given to the Contractor under the terms of the contract shall be served by sending the same by Registered Post / Speed Post/ FAX / Email to or leaving the same at the Contractor's last known address of the principal place of business (or in the event of the contractor being a company, to or at its Registered Office). In case of change of address, the notice shall be served at changed address as notified in writing by the Contractor to BHEL. Such posting or leaving of the notice shall be deemed to be good service of such notice and the time mentioned to the condition for doing any act after notice shall be reckoned from the date so mentioned in such notice.

2.3.2 Service of notice on BHEL Any notice to be given to BHEL in-charge under the terms of the Contract shall be served by sending the same by post or Email or leaving the same at BHEL address or changed address as notified in writing by BHEL to the Contractor.

2.4 USE OF LAND

No land belonging to BHEL or their Customer under temporary possession of BHEL shall be occupied by the contractor without written permission of BHEL.

2.4.1 STORES AND MATERIALS:

The contractor shall, at his own expense, supply all stores and materials required for the contract, other than those which may be provided by BHEL at the rates detailed therein subject to their availability at the place of issue indicated therein. All stores and materials to be supplied by the Contractor shall be of the best kind as described in the Specifications and the Contractor shall, if required by the Engineer –in- charge furnish him with proof to his satisfaction that the store and materials so comply with the specifications.



The contractor shall, at his own expense and without delay, supply samples of stores and materials proposed to be used in the execution of the work for the approval of the Engineer-in charge, who may reject all stores and materials not corresponding either in quality or character to the approved samples.

In the case of stores provided by BHEL, the Contractor shall bear the cost of loading, transporting to site, unloading, storing under cover as required, assembling & jointing the several parts together as necessary and incorporating & fixing these stores & materials in the work, including all preparatory work of whatever description that may be required, and closing, preparing, loading and returning empty cases or containers to the place of issue without any extra charges.

Contractor is responsible for safe & secure storage of above material.

2.4.2 PATENT RIGHTS:

The contractor shall fully indemnify BHEL, or the agent, servant, or employee of BHEL, against any action, claim or proceeding relating to infringement or the use of any patent or design or any alleged patent or design rights, and shall pay any royalties which may be payable in respect of any article/ or part thereof included in the contract.

In the event of any claims being made or action brought against BHEL, or any agent, or servant or employee of BHEL., in respect of any of the matters aforesaid, the contractor shall not apply when such increment has taken place in complying with the specific directions issued by the BHEL but the contractor shall pay any royalties payable in respect of any such use.

2.4.3 WATER:

The contractor shall allow in his tender and provide at his cost all water required for the work or his employees on the work, together with all pipes and fittings or other means that may be necessary or required to ensure a proper and ample supply of water for all purpose connected with the work.

In the event of a provision existing in the Tender documents for supply of water on payment by BHEL, water will be supplied from the BHEL supply System, or other sources at any points fixed by the Site Engineer/ Engineer-in-charge on the site of work. The contractor shall make necessary arrangement for lifting, pumping, carrying or conveying the water as required at his own cost. The levy of water charges to be borne by the Contractor in such case shall be specifically mentioned in the Tender documents.



2.4.4 TEMPORARY WORKSHOPS, STORES ETC.:

The Contractor shall, during the progress of the work provide, erect and maintain at his own expense all necessary temporary workshops, store, offices, toilets etc., required for the proper and efficient execution of the work. The planning, siting and erection of these building shall have the approval of the Engineer-in-charge and the Contractor shall at all times keep them in a clean and sanitized condition to the entire satisfaction of the Engineer-in-charge.

On completion of the work all such temporary buildings shall be cleared and the site restored to its original state in a clean and tidy condition to the entire satisfaction of the Engineer-in-charge.

2.5 COMMENCEMENT OF WORK

2.5.1 Time is essence of contract and is specified in the tender document or in each individual work order.

2.5.2 The contractor shall commence the work within seven (07) days from LOI/work order or as intimated by BHEL and shall proceed with the same with due expedition without delay.

2.5.3 If the contractor fails to start the work within stipulated time as per LOI or as intimated by BHEL, then BHEL at its sole discretion will have the right to cancel the contract. The Earnest Money and/or Security Deposit with BHEL will stand forfeited without any further reference to him without prejudice to any and all of BHEL's other rights and remedies in this regard.

2.5.4 All the work shall be carried out under the direction and to the satisfaction of BHEL.

2.6 MEASUREMENT OF WORK AND MODE OF PAYMENT:

2.6.1 All payments due to the contractors shall be made by electronic mode only, unless otherwise found operationally difficult.

2.6.2 For progress running bill payments: - The Contractor shall present detailed measurement sheets in triplicate, duly indicating all relevant details based on technical documents and connected drawings for work done during the month/period under various categories in line with terms of payment as per contract. The basis of arriving at the quantities, weights shall be relevant documents and drawings released by BHEL. These measurement sheets shall be prepared jointly with BHEL Engineers and signed by both the parties.

2.6.3 These measurement sheets will be checked by BHEL Engineer and quantities and percentage eligible for payment under various groups shall be decided by BHEL Engineer.



The abstract of quantities and percentage so arrived at based on the terms of payment shall be entered in Measurement Book and signed by both the parties.

2.6.4 Based on the above quantities, contractor shall prepare the bills in prescribed format and work out the financial value. These will be entered in Measurement Book and signed by both the parties. Payment shall be made by BHEL after effecting the recoveries due from the contractor.

2.6.5 All recoveries due from the contractor for the month/period shall be effected in full from the corresponding running bills unless specific approval from the competent authorities is obtained to the contrary.

2.6.6 Measurement shall be restricted to that portion of work for which it is required to ascertain the financial liability of BHEL under this contract.

2.6.7 The measurement shall be taken jointly by persons duly authorized on the part of BHEL and by the Contractor.

2.6.8 The Contractor shall bear the expenditure involved if any, in making the measurements and testing of materials to be used/used in the work. The contractor shall, without extra charges, provide all the assistance with appliances and other things necessary for measurement.

2.6.9 If at any time due to any reason whatsoever, it becomes necessary to re-measure the work done in full or in part, the expenses towards such re measurements shall be borne by the contractor unless such re measurements are warranted solely for reasons not attributable to contractor.

2.6.10 Passing of bills covered by such measurements does not amount to acceptance of the completion of the work measured. Any left out work has to be completed, if pointed out at a later date by BHEL.

2.6.11 Final measurement bill shall be prepared in the final bill format prescribed for the purpose based on the certificate issued by BHEL Engineer that entire works as stipulated in tender specification has been completed in all respects to the entire satisfaction of BHEL. Contractor shall give unqualified "No Claim" Certificate. All the tools and tackles loaned to him should be returned in satisfactory condition to BHEL. The abstract of final quantities and financial values shall also be entered in the Measurement Books and signed by both parties to the contract. The Final Bill shall be prepared and paid within a reasonable time after completion of work.



2.7 RIGHTS OF BHEL

BHEL reserves the following rights in respect of this contract during the original contract period or its extensions if any, as per the provisions of the contract, without entitling the contractor for any compensation.

2.7.1 To withdraw any portion of work and/or to restrict/alter quantum of work as indicated in the contract during the progress of work and get it done through other agencies to suit BHEL's commitment to its customer or in case BHEL decides to advance the date of completion due to other emergent reasons/ BHEL's obligation to its customer.

2.7.2 To terminate the contract or get any part of the work done through other agency or deploy BHEL's own/hired/otherwise arranged resources, at the risk and cost of the contractor after due notice of a period of two weeks by BHEL, in the event of: -

i) Contractor's continued poor progress

ii) Withdrawal from or abandonment of the work before completion of the work iii)

Contractor's inability to progress the work for completion as stipulated in the contract

iv) Poor quality of work

v) Corrupt act of Contractor

vi) Insolvency of the Contractor

vii) Persistent disregard to the instructions of BHEL

viii) Assignment, transfer, sub-letting of contract without BHEL's written permission

ix) Non fulfilment of any contractual obligations / non-compliance of statutory requirements

x) In the opinion of BHEL, the contractor is overloaded and is not in a position to execute

the job as per required schedule

2.7.3 To meet the expenses including BHEL overheads of 35% & Liquidated damage/penalties arising out of "Risk & Cost" as explained above under SI.No. 2.7.2. BHEL shall recover the amount from any money due from Contractor, from any money due to the Contractor including Security Deposit or by forfeiting any T&P or material of the contractor under this contract or any other contract of BHEL or by any other means or any combination thereof

2.7.4 To terminate the contract or to restrict the quantum of work and pay for the portion of work executed in case BHEL's contract with their customer are terminated for any reason, as per mutual agreement.



2.7.5 To effect recovery from any amounts due to the contractor under this or any other contract or in any other form, the moneys BHEL is statutorily forced to pay to anybody, due to contractor's failure to fulfil any of his obligations. BHEL shall levy overheads of 35% on all such payments.

2.7.6 While every endeavour will be made by BHEL to this end, they cannot guarantee uninterrupted work due to conditions beyond their control. The Contractor will not be normally entitled for any compensation/extra payment on this account unless otherwise specified elsewhere in the contract.

2.7.7 In case the execution of works comes to a complete halt or reaches a stage wherein worthwhile works cannot be executed and there is no possibility of commencement of work for a period of not less than two months, due to reasons not attributable to the contractor and other than Force Majeure conditions, BHEL may consider permitting the contractor to de mobilize forthwith and re mobilize at an agreed future date. Cost of such demobilization/remobilization shall be mutually agreed. ORC (Over run Charges) in such cases shall not be applicable for the period between the period of demobilization and re mobilisation. The duration of contract/time extension shall accordingly get modified suitably. In case of any conflict, BHEL decision in this regard shall be final and binding on the contractor.

2.7.8 In the unforeseen event of inordinate delay in receipt of materials, drawings, fronts, etc, due to which inordinate discontinuity of work is anticipated, BHEL at its discretion may consider contractor's request to short close the contract, provided that the balance works are minor vis a vis the scope of work envisaged as per the contract. At the point of requesting for short closure, contractor shall establish that he has completed all works possible of completion and he is not able to proceed with the balance works due to constraints beyond his control. In such a case, the estimated value of the unexecuted portion of work as mutually agreed, shall however be reduced from the final contract value.

2.7.9 LIQUIDATED DAMAGES/PENALTY

COMPENSATION FOR DELAY:

If the contractor fails to maintain the required progress in terms of condition 2.10 or to complete the work and clear the site on or before the contracted or extended the period of completion, he shall, without prejudice to any other right or remedy of the BHEL on account of such breach, pay as agreed compensation an amount calculated as stipulated below

For unfinished anticipated value of work where finished portion is fit for use

Rate of compensation as follows:



- Completion period (as originally stipulated) not exceeding 6 months.@ 1 percent per week
- Completion period (as originally stipulated) Exceeding 6 months and not exceeding 2 years...@ 0.5 percent per week
- Completion period (as originally stipulated) exceeding 2 years..... @ 0.25 percent per week

Provided always that the total amount of compensation for delay to be paid under condition shall not exceed the under noted percentage of the anticipated contract value

- Completion period (as originally stipulated) not exceeding 6 months.@ 10 percent of anticipated value of work
- Completion period (as originally stipulated) Exceeding 6 months and not exceeding 2 years...@ 7.5 percent of anticipated value of work
- Completion period (as originally stipulated) Exceeding 2 years.....@ 5 percent of anticipated value of work

The amount of compensation may be adjusted or set off against any sum payable to the Contractor under this or any other contract with the BHEL.

2.7.10 POST TECHNICAL AUDIT OF WORK AND BILLS: BHEL reserve the right to carry out a post-payment audit and technical examination of the work and final bill including all supporting vouchers, abstract etc., and to enforce recovery of any sums becoming due as a result thereof in the manner provided in the proceeding sub-paragraph's provided however that no such recovery shall be enforced after three years of passing the final bill

2.8 RESPONSIBILITIES OF THE CONTRACTOR IN RESPECT OF LOCAL LAWS, EMPLOYMENT OF WORKERS ETC.

The following are the responsibilities of the contractor in respect of observance of local laws, employment of personnel, payment of taxes etc. The subcontractor shall fully indemnify BHEL against any claims of whatsoever nature arising due to the failure of the contractor in discharging any of his responsibilities hereunder:

2.8.1 *The contractor at all times during the continuance of this contract shall, in all his dealings with local labour for the time being employed on or in connection with the work, have due regard to all local festivals and religious and other customs.*

2.8.2 *The contractor shall comply with all applicable State and Central Laws, Statutory Rules, Maternity act, Regulations etc. such as contract labour(R&A) Act 1970, Minimum wage Act 1974, Payment of wages Act 1936,ESI Act 1948, EPF Act 1952, Employees' compensation Act 1923, Provision of Companies Act 1948 & rules thereof, The interstate Migrant Workmen 1979, The Karnataka Factories Rules 1969, Payment of Bonus Act 1965, Payment of Gratuity Act 1972. Child labour Prohibition act 1986, Karnataka Minimum Wage Act , Prevention of sexual harassment at work place Act 2013, Guidelines/notification related to Safai Karamchari Act , Equal Remuneration Act 1976, The company's instructions as*

issued from time to time in regard to working hours, wages, leaves, holidays etc. for labour as may be enacted by the Government during the tenure of the Contract and having force or jurisdiction at Site. The Contractor shall also give to the local Governing Body, Police and other relevant Authorities all such notices as may be required by the Law.

The contractor shall produce the following registers and forms:

- Form XIII- Register of work men employed by contractor(Rule 75)
- Form XIV- Employment Card issued by contractor(Rule 76)
- Form XVI- Muster Roll (Rule 78(1) (a)(i))
- Form XVII- Register of Wages (Rule 78(1) (a)(i))
- Form XVIII- Register of wages cum Muster Roll(in case of weekly payment)
- Form XIX- Wage slip (Rule 78(b))
- Form XX- Register of deduction for damages Or Loss Rule 78(1) (a)(ii))
- Form XXI- Register of files Rule 78(1) (a)(ii))
- Form XXII- Register of Advance Rule 78(1) (a)(ii)) x Form XXIII- Register of Overtime Rule 78(1) (a)(iii))
- Form XXIV- Return to be sent by the contractor to the Licensing officer (Rule 82(1))

2.8.3 The contractor shall obtain independent License under the Contract Labour (Regulations and Abolition Act) as required from the concerned Authorities based on the certificate (Form-V) issued by the Principal Employer/Customer

2.8.4 The contractor shall pay all taxes, fees, license charges, deposits, duties, tolls, royalties, commission or other charges which may be levied on account of his operations in executing the contract.

2.8.5 While BHEL would pay the inspection fees and Registration fees of Boiler & explosive/Electrical Inspectorate, all other arrangements for site visits periodically by the Inspectorate to site, Inspection certificate etc. will have to be made by contractor. However, BHEL will not make any payment to the Inspectorate in connection with contractor's Welders/Electricians qualification tests etc.

2.8.6 Contractor shall be responsible for provision of Health and Sanitary arrangements (more particularly described in Contract Labour Regulation & Abolition Act), Safety precautions etc. as may be required for safe and satisfactory execution of contract.

2.8.7 The contractor shall be responsible for proper accommodation including adequate medical facilities for personnel employed by him.

2.8.8 The contractor shall be responsible for the proper behavior and observance of all regulations by the staff employed by him.



2.8.9 The contractor shall ensure that no damage is caused to any person/property of other parties working at site. If any such damage is caused, it is responsibility of the contractor to make good the losses or compensate for the same.

2.8.10 All the properties/equipment/components of BHEL/their Client loaned with or without deposit to the contractor in connection with the contract shall remain properties of BHEL/their Client.

2.8.11 The contractor shall use such properties for the purpose of execution of this contract. All such properties/equipment/components shall be deemed to be in good condition when received by the contractor unless he notifies within 48 hours to the contrary. The contractor shall return them in good condition as and when required by BHEL/their Client. In case of non-return, loss, damage, repairs etc, the cost thereof as may be fixed by BHEL Engineer will be recovered from the contractor

2.8.12 Any delay in completion of works/or non-achievement of periodical targets due to the reasons attributable to the contractor, the same may have to be compensated by the contractor either by increasing manpower and resources or by working extra hours and/or by working more than one shift. All these are to be carried out by the contractor at no extra cost.

2.8.13 The contractor shall arrange, coordinate his work in such a manner as to cause no hindrance to other agencies working in the same premises.

2.8.14 All safety rules and codes applied by the Client/BHEL at site shall be observed by the contractor without exception. The contractor shall be responsible for the safety of the equipment/material and works to be performed by him and shall maintain all light, fencing guards, slings etc. or other protection necessary for the purpose. Contractor shall also take such additional precautions as may be indicated from time to time by the Engineer with a view to prevent pilferage, accidents, fire hazards. Due precautions shall be taken against fire hazards and atmospheric conditions. Suitable number of Clerical staff, watch and ward, store keepers to take care of equipment/materials and construction tools and tackles shall be posted at site by the contractor till the completion of work under this contract. The contractor shall arrange for such safety devices as are necessary for such type of work and carry out the requisite site tests of handling equipment, lifting tools, tackles etc. as per prescribed standards and practices. Contractor has to ensure the implementation of Health, Safety and Environment (HSE) requirements as per directions given by BHEL/Customer. The contractor has to assist in HSE audit by BHEL/Customer and submit compliance Report. The contractor has to generate and submit record/reports as per HSE plan/activities as per instruction of BHEL/Customer. All tools, plant and equipment brought to the site shall become the property of BHEL and shall not be removed from the site without the prior written approval from BHEL. When the work is finally completed or the Contractor is determined for reasons other than the defaults of the contract, he shall forthwith remove from the site all tools, plants, equipment etc., (other than those as may have been provided by BHEL) and upon such removal, the same shall revert in, and become the property of the contractor.

2.8.15 The contractor will be directly responsible for payment of wages to his workmen on specified date of respective month declared as per applicable Labour Act. A pay roll sheet giving all the payments given to the workers and duly signed by the contractor's representative should be furnished to BHEL site for record purpose.

2.8.16 In case of any class of work for which there is no such specification as laid down in the contract, such work shall be carried out in accordance with the instructions and requirements of the Engineer.

2.8.17 Also, no idle charges will be admissible in the event of any stoppage caused in the work resulting in contractor's labour and Tools & Plants being rendered idle due to any reason at any time.

2.8.18 The contractor shall take all reasonable care to protect the materials and work till such time the plant/equipment has been taken over by BHEL or their Client whichever is earlier.

2.8.19 The contractor shall not stop the work or abandon the site for whatsoever reason of dispute, excepting force majeure conditions. All such problems/disputes shall be separately discussed and settled without affecting the progress of work. Such stoppage or abandonment shall be treated as breach of contract and dealt with accordingly

2.8.20 The contractor shall keep the area of work clean and shall remove the debris etc. while executing day-to-day work. Upon completion of work, the contractor shall remove from the vicinity of work, all scrap, packing materials, rubbish, unused and other materials and deposit them in places specified by the Engineer. The contractor will also demolish all the hutments, sheds, offices, etc. constructed and used by him and shall clean the debris. In the event of his failure to do so, the same will be arranged to be done by the Engineer and the expenses recovered from the contractor. If the work is executed in Factory premises, no hutment will be allowed.

2.8.21 The contractor shall execute the work in the most substantial and workman like manner in the stipulated time. Accuracy of work and timely execution shall be the essence of this contract. The contractor shall be responsible to ensure that the quality, assembly and workmanship conform to the dimensions and clearance given in the drawings and/ or as per the instructions of the Engineer.

2.8.22 The Contractor to note that some of BHEL's T&Ps/MMDs may not be insured. The Contractor will take necessary precautions and due care to protect the same while in his custody from any damage/ loss till the same is handed over back to BHEL. In case the damage / loss is due to carelessness/ negligence on the part of the contractor, the Contractor is liable to get them repair/ replaced immediately and in case of his failure to do so within a reasonable time, BHEL will reserve the right to recover the loss from the contractor.



2.8.23 The contractor shall provide all watchmen necessary, for the protection of the site, the work, the materials, the tools, plant, equipment and anything else lying on the site during the progress of the work. He shall solely be responsible for and shall take all reasonable and proper steps for protecting, securing, lighting and watching all places on or about the work and the site which may be dangerous to any person whom so ever.

2.8.24 SITE DRAINAGE: All water that may accumulate on the site during the process of the work, or in trenches and excavations shall be removed to the entire satisfaction of the Engineering-charge and at Contractors expense.

2.8.25 INSPECTION OF THE WORK: BHEL Officers concerned with the Contract shall have power at any time to inspect and examine any part of the work and the contractor shall give such facilities as may be required to given for such inspection and examination.

2.8.26 In case the contractor is required to undertake any work outside the scope of this contract, the rates payable shall be those mutually agreed upon if the item rates are not mentioned in existing contract

- i. For any item of wok required to be carried out after the contract has been awarded and which is not covered by Contractors Schedule but is covered by C.P.W.D. schedule of rates the rate payable for such a fresh item will be derived from updated C.P.W.D. schedule of rates by the method of proportion as follows:
- ii. Rate as per estimated updated C.P.W.D DSR and loading tender excess (plus or minus) on pro-rata basis for nearest analogous items. For other items rate as per estimated C.P.W.D DSR and loading tender excess(plus or minus) iii. If rates are not available in C.P.W.D. DSR, deviated item rates will be derived from market rate with 15% profit and overheads.

2.9 PROGRESS MONITORING, MONTHLY/ WEEKLY REVIEW AND PERFORMANCE EVALUATION

2.9.1 A detailed plan/programme for completion of the contractual scope of work as per the time schedule given in the contract shall be jointly agreed between BHEL and Contractor, before commencement of work. The above programme shall be supported by month/ week wise deployment of resources viz Manpower, T&P, Consumables, etc. Progress will be reviewed periodically (Daily/Weekly/Monthly) vis a vis this jointly agreed programme. The Contractor shall submit periodical progress reports (Daily/Weekly/Monthly) and other reports/information including manpower, consumables, T&P mobilization etc as desired by BHEL.

2.9.2 Monthly/ weekly progress review between BHEL and Contractor shall be based on the agreed programme as above, availability of inputs/fronts etc, and constraints if any, as per prescribed formats. Manpower, T&P and consumable reports as per prescribed formats shall

be submitted by contractor every month. Release of RA Bills shall be contingent upon certification by BHEL Site Engineer of the availability of the above prescribed formats duly filled in and signed.

2.9.3 The burden of proof that the causes leading to any shortfall is not due to any reasons attributable to the contractor is on the contractor himself. The monthly progress review shall record shortfalls attributable to (i) Contractor, (ii) Force Majeure Conditions, and (iii) BHEL

2.10 TIME OF COMPLETION

2.10.1 Time is essence of the contract. The time schedule shall be as prescribed in the Contract. The time for completion shall be reckoned from the date of commencement of work at Site as certified by BHEL Engineers

2.10.2 The entire work shall be completed by the contractor within the time schedule or within such extended periods of time as may be allowed by BHEL under clause 2.11

2.11 EXTENSION OF TIME FOR COMPLETION

2.11.1 If the completion of work as detailed in the scope of work gets delayed beyond the contract period, the contractor shall request for an extension of the contract and BHEL at its discretion may extend the Contract.

2.11.2 Based on the monthly reviews jointly signed, the works balance at the end of original contract period less the backlog attributable to the contractor shall be quantified, and the number of months of 'Time extension' required for completion of the same shall be jointly worked out. Within this period of 'Time extension', the contractor is bound to complete the portion of backlog attributable to the contractor. Any further 'Time extension' or 'Time extensions' at the end of the previous extension shall be worked out similarly.

2.11.3 However if any 'Time extension' is granted to the contractor to facilitate continuation of work and completion of contract, due to backlog attributable to the contractor alone, then it shall be without prejudice to the rights of BHEL to impose penalty/LD for the delays attributable to the contractor, in addition to any other actions BHEL may wish to take at the risk and cost of contractor.

2.11.4 A joint programme shall be drawn for the balance amount of work to be completed during the period of 'Time Extension', along with matching resources (with weightages) to be deployed by the contractor as per specified format. Review of the programme and record of shortfall shall be done every month of the 'Time extension' period in the same manner as is done for the regular contract period.

2.11.5 During the period of 'Time extension', contractor shall maintain their resources as per mutually agreed program

2.11.6 At the end of total work completion as certified by BHEL Engineer, and upon analysis of the total delay, the portion of time extensions attributable to (i) Contractor, (ii) Force majeure conditions, and (iii) BHEL, shall be worked out and shall be considered to be exhausted in the same order. The total period of time extensions shall be the sum of (i), (ii) and (iii) above and shall be equal to period between the scheduled date of completion and the actual date of completion of contract. LD shall be imposed/levied for the portion of time extensions attributable to contractor and recoverable from the dues payable to the contractor.

2.12 OVERRUN COMPENSATION (THIS CLAUSE IS NOT APPLICABLE IN BHEL FACTORY & TOWNSHIP PREMISES)

2.12.1 Over Run Compensation (ORC) is payable by way of rate revisions for periods beyond original, contract period subject to the following terms and conditions.

2.12.2 Rates shall be increased by 10% for the first twelve months of one or more extensions beyond original contract period. For the next twelve months of further extensions if any, rates shall be increased as above by 10% over the previous twelve months, and similarly for each subsequent twelve months extension.

2.12.3 Should there be any 'Time extension' for reasons attributable only to the contractor, then the work shall be executed by the contractor at the rates applicable for the period the work was planned

2.12.4 Payment of ORC shall be regulated as follows:

i) Contractor is entitled to Over Run Compensation (ORC) only for the portion of backlog attributable to BHEL.

ii) 50% of the compensation is allocated for deployment of resources agreed as per the joint programme drawn vide 2.11.4. Payment shall however be based on the actual deployment of resources for the month as certified by BHEL, as per weightages assigned therein

iii) 50% of the compensation, is allocated for achieving of planned progress agreed as per the joint programme drawn vide 2.11.4. Payment shall be on pro rata basis for actual achieved quantities

iv) Total Over Run Compensation shall be limited to 10% of the executed contract value as certified in Final Bill. For this purpose, executed contract value excludes PVC, ORC, Supplementary/Additional Items and Extra Works done on Man-day rate basis

2.12.5 Contractor shall not be entitled for any Over Run Compensation (ORC) for the portion of backlog attributable to the contractor. Such works shall be executed at the rates applicable for the period the work was planned

2.13 **QUANTITY VARIATION**

2.13.1 *The quoted rates shall remain firm irrespective of any variations in the individual quantities.*

2.14 **EXTRA WORKS**

2.14.1 *All rectifications/modifications, revamping, and reworks required for any reasons not attributable to the contractor, or needed due to any change in deviation from drawings and design of equipment, operation/maintenance requirements, mismatching, or due to damages in transit, storage and erection/commissioning, and other allied works which are not very specifically indicated in the drawings, but are found essential for satisfactory completion of the work, will be considered as extra works.*

2.14.2 *Extra works arising on account of the contractor's fault, irrespective of time consumed in rectification of the damage/loss, will have to be carried out by the contractor free of cost. Under such circumstances, any material and consumable required for this purpose will also have to be arranged by the contractor at his cost.*

2.14.3 *All the extra work should be carried out by a separately identifiable gang, without affecting routine activities. Daily log sheets in the pro-forma prescribed by BHEL should be maintained and shall be signed by the contractor's representative and BHEL engineer. No claim for extra work will be considered/entertained in the absence of the said supporting documents i.e. daily log sheets. Signing of log sheets by BHEL engineer does not necessarily mean the acceptance of such works as extra works.*

2.14.4 *BHEL retains the right to award or not to award any of the major repair/rework/modification/rectification/fabrication works to the contractor, at their discretion without assigning any reason for the same*

2.14.5 *After eligibility of extra works is established and finally accepted by BHEL engineer/designer, payment will be released on competent authority's approval at the following rate.*

MAN-HOUR RATE FOR ELIGIBLE EXTRA WORKS: *Single composite average labour manhour rate, including overtime if any, supervision, use of tools and tackles and other site expenses and incidentals, consumables for carrying out any major rework/repairs/rectification/modification/fabrication as certified by site as may arise during the course of erection, testing, commissioning or extra works arising out of transit, storage and erection damages, payment, if found due will be as per applicable minimum wage act*

2.14.6 *The above composite labour man hour rate towards extra works shall remain firm and not subject to any variation during execution of the work. PVC will not be applicable for extra works. Rate revision, Over Run Charges/compensation etc will not be applicable due to extra works.*

2.14.7 Extra Works for Civil Packages shall be regulated as follows

i) Rates for Extra Works arising due to (1) non availability of BOQ (Rate Schedule), OR (2) change in Specifications of materials/works (3) rectification/modification/dismantling & re-erecting etc due to no fault of Contractor, shall be in the order of the following:

a) Item rates are to be derived from similar nature of items in the BOQ (Rate Schedule) with applicable escalation derived from All India Consumer Price Index for Whole Sale Commodities.

b) As per applicable updated CPWD-DSR (or latest edition) with applicable escalation derived, Notification issued by the office of CPWD for 'Cost Index' in that Region where the project is being executed,

c) Item rates are to be worked out on the basis of prevailing market rates mutually agreed between BHEL and Contractor, plus 15% towards Contractor's overheads and profit.

ii) PVC and ORC will not applicable be for (i) above.

2.15 **SUPPLEMENTARY ITEMS**

2.15.1 For NON Civil Works

Supplementary items are items/works required for completion of entire work but not specified in the scope of work. Subject to certification of such items/works as supplementary items by BHEL Engineer, rates shall be derived on the basis of any one of the following on mutual agreement:

i) Based on percentage breakup/rates indicated for similar/nearby items

ii) In case (i) above does not exist, then BHEL/site may derive the percentage breakup/rates to suit the type of work

2.15.2 For Civil Works

i) Rates for Supplementary Works/Additional Works arising out due to additions/alterations in the original scope of works as per contract subject to certification of BHEL Engineer shall be worked out as under:

a) Item rates which are available in existing BOQ (Rate Schedule) shall be operated with applicable escalation derived from All India Consumer Price Index for Whole Sale Commodities

b) Items of works which are not available in existing BOQ shall be operated as an 'Extra Works' and rate shall be derived as per clause no 2.14



ii) Execution of Supplementary Works/Additional Works through the Contractor shall be at the sole discretion of BHEL, and shall be considered as part of executed contract value for the purpose of Quantity Variation as per clause 2.13

iii) BHEL Engineer's decision regarding fixing the rate as above is final and binding on the contractor. iv) PVC and ORC will not be applicable for (i) above.

2.16 STRIKES & LOCKOUT

2.16.1 The contractor will be fully responsible for all disputes and other issues connected with his labour/employee. In the event of the contractor's labour/employee resorting to strike or the Contractor resorting to lockout and if the strike or lockout declared is not settled within a period of 15 days, BHEL shall have the right to get the work executed through any other agencies and the cost so incurred by BHEL along with Overhead charges of 35% shall be deducted from the Contractor's bills along with overhead of 35%

2.16.2 For all purposes whatsoever, the employees of the contractor shall not be deemed to be in the employment of BHEL

2.17 FORCE MAJEURE

The following shall amount to Force Majeure: -

2.17.1 Acts of God, act of any Government, War, Sabotage, Riots, Strike, Civil commotion, Police action, Revolution, Flood, Fire, Cyclones, Earth quake and Epidemic and other similar causes over which the contractor has no control.

2.17.2 If the contractor suffers delay in the due execution of the contractual obligation due to delays caused by force majeure as defined above, the agreed time of completion of the job covered by this contract or the obligations of the contractor shall be extended by a period of time equal to period of delay, provided that on the occurrence of any such contingency, the contractor immediately reports to BHEL in writing the causes of delay and the contractor shall not be eligible for any compensation.

2.18 ARBITRATION & RECONCILIATION

2.18.1 In case amicable settlement is not reached in the event of any dispute or difference arising out of the execution of the Contract or the respective rights and liabilities of the parties or in relation to interpretation of any provision by the Contractor in any manner touching upon the Contract, such dispute or difference shall (except as to any matters, the decision of which is specifically provided for therein) be referred to the sole arbitration of the arbitrator appointed by BHEL/In charge.

The award of the Arbitrator shall be binding upon the parties to the dispute Subject as aforesaid, the provisions of Arbitration and Reconciliation Act 1996 (India) or statutory

modifications or reenactments thereof and the rules made there under and for the time being in force shall apply to the arbitration proceedings under this clause. The venue of the arbitration shall be the place from which the contract is issued or such other place as the Arbitrator at his discretion may determine

2.18.2 In case of Contract with Public Sector Enterprise (PSE) or a Government Department, the following shall be applicable:

In the event of any dispute or difference relating to the interpretation and application of the provisions of the Contract, such dispute or difference shall be referred to by either party to the arbitration of one of the arbitrators in the department of public enterprises. The award of the arbitrator shall be binding upon the parties to the dispute, provided, however, any party aggrieved by such award may make further reference for setting aside or revision of the award to the Law Secretary, Department of Legal Affairs, Ministry of Law and Justice, Government of India. Upon such reference the dispute shall be decided by the Law Secretary or the Special Secretary or Additional Secretary when so authorized by the Law Secretary, whose decision shall bind the parties hereto finally and conclusively.

2.18.3 The cost of arbitration shall be borne equally by the parties.

2.18.4 Work under the contract shall be continued during the arbitration proceedings

2.19 **PAYMENTS**

Payments to Contractors are made in any one of the following forms

2.19.1 Running Account Bills (RA Bills)

- i) These are for interim payments when the contracts are in progress. The bills for such interim payments are to be prepared by Contractor in prescribed formats (RA Bill forms).
- ii) Payments shall be made according to the extent of work done as per measurements taken up to the end of the calendar month and in line with the terms of payments described in the Tender documents along with relevant statutory documents applicable for the work.
- iii) Recoveries on account of electricity, water, statutory deductions, etc are made as per terms of contract
- iv) Full rates for the work done shall be allowed only if the quantum of work has been done as per the specifications stipulated in the contract. If the work is not executed as per the stipulated specifications, BHEL may ask the contractor to re do the work according to the required specifications, without any extra cost. However, where this is not considered necessary 'OR' where the part work is done due to factors like non-availability of material to be supplied by BHEL 'OR' non availability of fronts 'OR' non availability of drawings, fraction payment against full rate, as is considered reasonable, may be allowed with due regard for



the work remaining to be done. BHEL decision in this regard will be final and binding on the contractor.

v) In order to facilitate part payment, BHEL Site Engineer at his discretion may further split the contracted rates/percentages to suit site conditions, cash flow requirements according to the progress of work

2.19.2 Final Bill

'Final Bill' is used for final payment on closing of Running Account for works or for single payment after completion of works. 'Final Bill' shall be submitted as per prescribed format after completion of works as per scope and upon material reconciliation, along with the following.

- i) 'No Claim Certificate' by contractor
- ii) Clearance certificates where ever applicable viz Clearance Certificates from Customer, various Statutory Authorities like Labour department, PF Authorities, Commercial Tax Department, etc
- iii) Indemnity bond as per prescribed format BHEL shall settle the final bills after deducting all liabilities of Contractor to BHEL

2.20 PERFORMANCE GUARANTEE FOR WORKMANSHIP

2.20.1 Even though the work will be carried out under the supervision of BHEL Engineers the Contractor will be responsible for the quality of the workmanship and shall guarantee the work done for a period of as mentioned in the contract/NIT from the date of commencement of guarantee period as defined in Technical Conditions of Contract, for good workmanship and shall rectify free of cost all defects due to faulty erection detected during the guarantee period. In the event of the Contractor failing to repair the defective works within the time specified by the Engineer, BHEL may proceed to undertake the repairs of such defective works at the Contractor's risk and cost, without prejudice to any other rights and recover the same from the balance security deposit.

2.20.2 BHEL shall release the balance security deposit subject to the following

- i) Contractor has submitted 'Final Bill'
- ii) Guarantee period as per contract has expired
- iii) Contractor has furnished 'No Claim Certificate' in specified format
- iv) BHEL Site Engineer/Construction Manager has furnished the 'No Demand Certificate' in specified format



v) Contractor has carried out the works required to be carried out by him during the period of Guarantee and all expenses incurred by BHEL on carrying out such works is included for adjustment from the Guarantee money refundable.

2.21 CLOSING OF CONTRACTS

The Contract shall be considered completed and closed upon completion of all contractual obligations and settlement of Final Bill or completion of Guarantee period whichever is later. Upon closing of Contract, BHEL shall issue a completion certificate as per standard format, based on specific request of Contractor.

2.22 REVERSE AUCTION/PRICE BID OPENING:

- BHEL reserves the right to go for reverse auction at any point of time before opening of Price Bid.
- Bids with non-acceptance of reverse auction will be liable for rejection.
- Opening of Price Bid at discretion of BHEL.
- BHEL shall be at liberty to cancel the tender at any time, before ordering, without assigning any reason.

2.23 SUSPENSION OF BUSINESS DEALINGS

BHEL reserves the right to take action against Contractors who either fail to perform or Tenderers/Contractor who indulge in malpractices, by suspending business dealings with them in line with BHEL guidelines issued from time to time.

2.24 OTHER ISSUES

2.24.1 Value of Non judicial Stamp Paper for Bank Guarantees and for Contract Agreement shall be not less than Rs 200/- unless otherwise required under relevant statutes.

2.24.2 In case of any conflict between the General Conditions of Contract and Special Conditions of Contract, provisions contained in the Special Conditions of Contract shall prevail.

2.24.3 Unless otherwise specified in NIT, offers from consortium/JVs shall not be considered.

2.24.4 BHEL may not insist for signing of Contract Agreements in respect of low value and short time period contracts