

BHARAT HEAVY ELECTRICALS LIMITED
Tiruchirapalli-620014

Pre-Qualification Requirement (To be submitted in Part-I bid)

Ref: ENBPS02346

1. Vendor to furnish records of previous supplies of same or similar category items to any Central / State Govt Organization / PSU / Public Listed Company: To fulfil this criteria vendor shall submit previous records not more than 5 years old from date of part 1 bid opening.

2. Vendor should manufacture the items as per BHEL specification. To fulfil this criteria vendor shall submit the specification duly sealed and signed.

Scope of Supply

Item No	Material Code	Material Description	Drawing/Rev No	Quantity (Nos)	Delivery Period (Weeks)
10	964528620000	MCN WASHER-D14.35 -EN42-5903	3V590306545/00	1000	16 Weeks
20	964528630000	MCN WASHER-D16.67 -EN42-5913	3V591306545/00	1000	16 Weeks
30	964528650000	MCN WASHER-D20.63 -EN42--5914	3V591406545/00	500	16 Weeks
40	964528660000	MCN WASHER-D22.30 -EN42-5906	3V590606545/00	300	10 Weeks
50	964528670000	MCN WASHER-D26.60 -EN42-5916	3V591606545/00	300	10 Weeks
60	964530030000	METAL. END COVER-W001	2VW00115483/03	200	10 Weeks
70	964530260000	METAL. END COVER-L121	2VL12115483/03	10	10 Weeks
80	964536450000	METTALIC ENDCOVER-N593	3VN59323461/02	20	10 Weeks
90	964536900000	METALIC END COVER-C520	3VC52023461/02	83	6 Weeks
100	964605550000	METAL END COVER 16/150-L943	3VL94322267/01	10	6 Weeks
110	964621530000	METAL END COVER-LC67	3VLC6722267/00	10	10 Weeks
120	964665520000	METTALIC ENDCOVER-G390	2VG39015483/01	50	6 Weeks
130	964665570000	METAL.END COVER-DIA 184 X 75-V711	2VV71115483/01	50	6 Weeks
140	964665580000	METAL.END COVER-DIA 254 X 60-V768	2VV76815483/01	10	6Weeks
150	964665590000	METAL.END COVER-DIA 222 X 80-V756	2VV75615483/00	10	6 Weeks
160	964665640000	METAL. END COVER-L442	2VL44215483/00	12	6 Weeks



BHARAT HEAVY ELECTRICALS LTD

VALVES PURCHASE

Trichy - 620 014. India

CONFIRMATION TO TERMS AND CONDITIONS

Enquiry Reference: ENBPS02346

<u>TERMS & CONDITION</u>	<u>VENDOR CONFIRMATION</u>
a. Vendor Quotation Ref. No. and Date	
b. Vendor should give confirmation to BHEL's Technical Specification. Any deviations from the specification are to be furnished separately as "Schedule of Deviation". If there is no deviation vendor should indicate "No Deviation" .	
c. The offer has to be submitted as a Two-part bid (Techno-commercial & Price bid)	
d. The tender will be finalized on item wise basis	
e. Terms of Payment: <u>Indigenous Supplier (Non-MSE):</u> 100% direct EFT Payment after 60 days from the date of receipt and acceptance of materials at BHEL stores / against site acknowledgement. <u>Indigenous Supplier (MSE):</u> Payment will be as per MSMED Act, 2006	
f. Liquidated Damage: Liquidated damages shall be 0.5% of the undelivered portion per week of the delay or part thereof subject to a maximum of 10% of the total order value.	
g. Delivery Terms: Prices shall be quoted on "FIRM PRICE" basis only. <u>For Indigenous Supplies:</u> FOR BHEL Trichy	
h. Validity of Offer: Prices should be valid for 60 days from the date of part-1 bid opening of this tender. The delay in responding to BHEL technical clarification beyond four days will be subsequently added to the validity period, Revised Price Bids will not be encouraged.	
i. Delivery period: Delivery period should be 6-16 weeks from the date of purchase order. If supplier offers more than the required delivery period BHEL will operate 0.5% loading factor for evaluation of their offer for every week delay subject to a maximum of 2%. Any other delivery period after loading to maximum will be rejected.	
j. Risk Purchase: Risk purchase penalties as per clause 5 of general terms and conditions is applicable for this enquiry. Non acceptance to risk purchase clause the offer is liable for rejection.	
k. Guarantee Clause: The vendor shall give a guarantee for the performance of his supplies for a period of eighteen months from the date of dispatch or twelve months from the date of commissioning whichever is earlier.	
l. Performance Bank Guarantee: Performance Bank Guarantee is not applicable for this enquiry	



BHARAT HEAVY ELECTRICALS LTD

VALVES PURCHASE

Trichy - 620 014. India

CONFIRMATION TO TERMS AND CONDITIONS

Enquiry Reference: ENBPS02346

<u>TERMS & CONDITION</u>	<u>VENDOR CONFIRMATION</u>
m. Counter-offering Counter-offering is not applicable for this enquiry	
n. Integrity Pact Integrity pact is not applicable for this enquiry	



Maharatna Company

BHARAT HEAVY ELECTRICALS LTD

VALVES PURCHASE

Trichy - 620 014, India

GENERAL TERMS AND CONDITIONS

Enquiry Reference: **ENBPS02346**

1. QUOTATIONS:

a. BID system:

- i. **Two part bid:** The offers are invited in Two part bid system (Part I will be Techno-commercial bid and part II will be Price Bid). Techno-commercially suitable vendors alone will be intimated for price bid opening.

b. Submission of offer:

Offer called through Non-e-Procurement mode: Each part of offer should be sent in a double cover separately and the same should be sealed and super scribed with details such as enquiry reference, name of the vendor, item of supply and due date of opening. Two or more quotations should not be sent in one cover. Price Bid should contain only "Price per unit" for each type. Offer should be sent to the below mentioned address:

The Tender Opening Cell / Valves
Room No. -26, Building -24
Bharat Heavy Electricals Limited
Tiruchirappalli - 620014, Tamil Nadu, India
Or

Email ID: tender_cell@bhel.in

- c. **Late offers:** Offer received after 2.00 pm on due date will be considered as Late offers. Late offers will not be considered under any circumstance.
- d. **Regulations:** Offers should be free from correction and erasures. Corrections if any must be attested. All amounts shall be indicated both in words as well as figures. In case of a difference between the amount quoted in words and figures, the amount quoted in words shall prevail.
- e. **PVC:** Price Variation clause not acceptable. Prices should be firm.
- f. **Catalogue:** Manufacturer's name, Trade Mark or Patent No. if any should be specified. Illustrative leaflets giving technical particulars are required along with quotation.
- g. **Samples:** Samples should be submitted separately, if specially requested in tender, before the due date of the enquiry. They should be clearly marked with the enquiry reference and date on the enclosing cover to facilitate identification.
- h. **GST Number:** GST registration number, HSN number (Item wise) with applicable taxes should be mentioned in the offer. If the vendor is not GST registered the offer is liable for rejection.
- i. **Deviation.** Any deviations from the specification are to be furnished separately as "Schedule of Deviation". If there is no deviation, vendor should indicate "No Deviation" in the offer.
- j. **Confirmation:** Confirmation for compliance is to be given in the offer for all the techno commercial conditions specified in the tender.

2. COMMERCIAL TERMS & CONDITIONS:

a. Terms of Payment:

For Indigenous Suppliers:

If the materials are receivable at BHEL Stores, Trichy:

Payment term is 100% direct Payment after 60 days from the date of receipt and acceptance of materials.

Any deviation in the above payment terms, any other conditions in payment terms or any other payment terms will not be accepted and offers will not be considered.

For New Suppliers: For new suppliers not registered with BHEL, Trichy for the product, payment shall be made 60 days after receipt and acceptance of materials.

- b. **Liquidated Damage:** Liquidated damages shall be 0.5% of the undelivered portion per week of the delay or part thereof subject to a maximum of 10% of the total order value.



BHARAT HEAVY ELECTRICALS LTD

VALVES PURCHASE

Trichy - 620 014, India

GENERAL TERMS AND CONDITIONS

Enquiry Reference: **ENBPS02346**

Any deviation from the above LD clause, loading will be applied to the extent to which it is not agreed by the bidder (at offered value)

Under GST regime, BHEL has to discharge GST liability on LD recovered from suppliers. Hence applicable GST shall also be recoverable from suppliers on LD amount. Debit note will be issued by BHEL for this amount, indicating the respective supply invoice number.

c. Delivery Terms:

For Indigenous Suppliers: FOR BHEL Trichy inclusive of freight and insurance

- d. Validity of Offer:** Prices should be fixed and should be valid for period as mentioned in the "Confirmation to the Terms and Conditions" attached.
- e. Delivery period:** Delivery schedule will be as mentioned in the "Confirmation to the Terms and Conditions" attached. If supplier offers more than the required delivery period BHEL will operate 0.5% loading factor for evaluation of their offer for every week delay.
- f. Guarantee period:** The vendor shall give a guarantee for the performance of his supplies for a period of **eighteen months** from the date of dispatch or **twelve months** from the date of commissioning whichever is earlier.
- g. Miscellaneous:** Any conditions which might have been quoted by the seller and are in contravention to the terms of PO and which have not been specifically accepted by Purchaser will not be applicable to the contract/PO.
- h. Performance Bank Guarantee:** If tender calls for Performance Bank Guarantee, vendor should provide a performance bank guarantee (PBG) in BHEL format for 10% of the total Purchase order value valid for warranty/guarantee period with an additional claim period of 2 months. PBG should be issued from list of consortium banks.
- i. Counter Offering:** If counter offering is applicable for the enquiry, the L1 rates will be counter-offered to other eligible vendors as per below points
- In case there are only two qualified offers for any item, the L1 rate will be counter-offered to the L2 vendor.
 - In case of more than two qualified offers for any item, the L1 rates will be counter-offered to maximum (n-1) vendors (where 'n' is the no. of techno-commercially qualified vendors) or the no. of vendors required (as mentioned in the "Confirmation to the Terms and Conditions" attached), whichever is lower.
 - In case a lower ranked vendor does not accept the counter-offered rates, the rates may be offered to next higher ranked vendor.
 - The manner of splitting of the enquiry quantity across L1 and counter-offer accepted vendors will be as per the ratios mentioned in the "Confirmation to the Terms and Conditions" attached.

3. COMPLIANCE / ACCEPTANCE REQUIRED FOR FOLLOWING POINTS TO ENSURE INPUT TAX CREDIT

- a.** Response to Tenders for Indigenous supplier/Vendor will be entertained only if the vendor has a valid GST registration No (GSTIN) which should be clearly mentioned in the offer. If the Vendor is exempted from GST registration, a declaration with due supporting documents need to be furnished for considering the offer. Vendor under composition scheme should declare that he is a composition Vendor supported by the screen shot taken from GST portal. The dealer has to submit necessary documents if there is any change in status under GST.
- b.** Supplier shall mention their GSTIN in all their invoices (incl. credit Notes, Debit Notes) and invoices shall be in the format as specified/prescribed under GST laws. Invoices shall necessarily contain Invoice number (in case of multiple numbering system is being followed for billing like SAP invoice no, commercial invoice no etc., then the Invoice No. which is linked/uploaded in GSTN network shall be clearly indicated), Billed to party (with GSTIN) & Shipped to party details, item description as per PO, Quantity, Rate, Value, applicable taxes with nomenclature (like IGST, SGST, CGST & UTGST) separately, HSN/ SAC Code, Place of Supply etc.
- c.** Invoices will be processed only upon completion of statutory requirement and further subject to following:
- i. Vendor declaring such invoice in Form GST ANX-1
 - ii. Receipt of Goods or Services and Tax invoice by BHEL
- d.** All invoices shall bear the HSN Code for each item separately (Harmonized System of Nomenclature)/ SAC code (Services Accounting Code).
- e.** As the continuous uploading of tax invoices in GSTN portal (in GST ANX-1) is available for all (i.e. both Small & Large) tax payers under proposed new GST Return System, all invoice raised on BHEL may be uploaded immediately in GST portal on despatch of material /rendering of services. The supplier shall ensure availability of Invoice in GST portal before submission of invoice to BHEL. Invoices will be admitted by BHEL only if the invoices are available in GSTN portal (in BHEL's GST ANX-2).



BHARAT HEAVY ELECTRICALS LTD

VALVES PURCHASE

Trichy - 620 014, India

GENERAL TERMS AND CONDITIONS

Enquiry Reference: **ENBPS02346**

- f. A declaration to the effect that all invoice particulars are/were uploaded in the GSTN network/ portal & all tax liability as per GST rules and regulations have been and will be discharged, shall be mentioned in the invoice. If not mentioned in the invoice, a separate declaration shall be submitted as per the requirement of BHEL.
- g. All documents like Test Certificate, LR copy, any other document mentioned in PO, shall be sent along with the vehicle/consignment. For all consignments received within the calendar month, input credit will be availed within that month in line with monthly returns filing cycle. In case of any discrepancy in the document or non-submission of documents mentioned in the PO, then BHEL will not be able to accept or account the material, in such case availing of tax credit will be deferred to next month or so.
- h. In case of discrepancy in the data uploaded by the supplier in the GSTN portal or in case of any shortages or rejection in the supply, then BHEL will not be able to avail the tax credit and will notify the supplier of the same. Supplier has to rectify the data discrepancy in the GSTN portal or issue credit note or debit note (details also to be uploaded in GSTN portal) for the shortages or rejections in the supplies or additional claims, within the calendar month informed by BHEL.
- i. In cases where invoice details have been uploaded by the vendor but failed to remit the GST amount to GST Department (Form PMT-08 or Form GST RET-01 to be submitted) within stipulated time, then GST paid on the invoices pertaining to the month for which GST return not filed by the vendor will be recovered from the vendor along with the applicable interest (currently 24% p.a) and all subsequent bills of the vendor will not be processed till filing of the GST return by the vendor.
- j. Under GST regime, BHEL has to discharge GST liability on LD recovered from suppliers/contractors. Hence applicable GST shall also be recoverable from suppliers/contractors on LD amount. For this, debit note will be issued by BHEL indicating the respective supply invoice number.
- k. In case any changes in taxes and duties as per Gov. Notification (including GST), the same shall be applicable from time to time.
- l. Duplicate copy of the Invoice meant for the transporter should accompany the material as stipulated under CE Rules 52A and 172C OR 57CE.
- m. TDS on GST shall be applicable as per the GST Act.
- n. In case GST credit is denied to BHEL due to non-receipt or delayed receipt of goods and/ or tax invoice or expiry of timeline prescribed in GST law for availing such ITC, or any other reasons not attributable to BHEL, GST amount claimed in the invoice shall be disallowed to the vendor.
- o. Where any GST liability arising on BHEL under Reverse Charge (RCM), the vendor has to submit the invoices to BHEL well within the timeline prescribed in GST Law, to enable BHEL to discharge the GST liability. If there is a delay in submission of invoice by the vendor resulting in delayed payment of GST by BHEL along with Interest, then such Interest payable or paid shall be recovered from the vendor.
- p. GST TDS will be deducted as per Section 51 of CGST Act 2017 and in line with Notification 50/2018 – Central Tax dated 13.09.2018. GST TDS certificate which will be generated in GST portal subsequent to vendor accepting the TDS deduction in the GST portal, will be issued to the vendor.

4. SPECIAL PROVISIONS FOR MICRO AND SMALL ENTERPRISES (MSE):

- a. 25% of the tendered quantity is earmarked for MSE suppliers in this tender.
- b. If L1 vendor (or) Counter offer accepted vendor/s is from a Micro / Small enterprise which put together covers 25% of the total tendered quantum, the 25% earmarking provision is not applicable.
- c. Out of the 25% tendered quantity reserved for MSE suppliers, 6.25% shall be earmarked for procurement from MSE owned by SC / ST entrepreneurs. In the event of failure of such Micro and Small enterprises to participate in the tender process or meet the tender requirements and the L1 price, the 6.25% sub-target for procurement ear-marked MSE owned by SC / ST entrepreneurs shall be met with other MSE enterprise/s.
- d. 3% reservation for women owned MSEs within the above mentioned 25% reservation. In the event of failure of such Micro and Small enterprises to participate in the tender process or meet the tender requirements and the L1 price, the 3% sub-target for procurement ear-marked MSE owned by women entrepreneurs shall be met with other MSE enterprise/s. The definition for MSEs owned by Women Entrepreneurs is clarified as:
 - i. In case of proprietary MSE, proprietor shall be woman.
 - ii. In case of partnership MSE, the women partners shall be holding at least 51% share in the unit.
 - iii. In case of private limited companies, at least 51% share shall be held by the women promoters.



Maharatna Company

BHARAT HEAVY ELECTRICALS LTD

VALVES PURCHASE

Trichy - 620 014, India

GENERAL TERMS AND CONDITIONS

Enquiry Reference: **ENBPS02346**

- e. In case MSE vendor participating in the tender quotes within the price band of L1 +15%, they will be allowed to supply the portion of the requirement subject to acceptance of L1 price by MSE vendor. In case of more than one such MSE, the supply shall be shared proportionately, provided the available quantum can be split.
- f. In a tender where both MSE and Non-MSE Vendors have participated and non-MSE Vendor has become the lowest bidder and the quantum envisaged in the tender cannot be split, then the MSE vendor will be given preference for ordering the available quantum provided the MSE vendor quoted price is within L1 + 15%, and if the MSE vendor accepts the L1 rate.
- g. MSE suppliers can avail the intended benefits only if,
The vendor submits along with offer, a copy of the Udhog Aadhar and a certificate, as per the format in Annexure-A, issued by a chartered accountant during the financial year of the date of part-1 bid opening, certifying that the quantum of investment in plant and machinery is within the permissible limit as per the act for relevant status (Micro or small).

(or)

The vendor has already submitted the above documents for the financial year of the date of part-1 bid opening and the MSE status has been updated in BHEL Trichy's records.

Non submission of such documents will lead to consideration of their bids at par with other bidders and MSE status of such suppliers shall be shifted to Non MSE supplier till the supplier submits these documents.

- h. Definitions of MSEs owned by SC/ST is under:
 - i. In case of proprietorship firm, proprietor must be SC/ST.
 - ii. In case of partnership firm, the SC/ST partners must be holding at least 51% shares in the unit.
 - iii. In case of private limited companies, at least 51% share must be held by SC/ST promoters.
 - iv. The caste/Tribe/Community certificate issued by the following authorities in the prescribed form for SCs/STs can be considered.
- i. Authorized to Issue SC/ST certificate:
 - i. District Magistrate/Additional District Magistrate/Collector/Deputy commissioner/Additional Deputy Commissioner/Deputy collector/1st class stipendiary magistrate/Sub divisional Magistrate/Taluka Magistrate/Executive magistrate/Extra Assistant commissioner.
 - ii. Chief Presidency magistrate/Additional chief presidency magistrate/Presidency magistrate.
 - iii. Revenue Officer not below the rank of tehsildar.
 - iv. Sub-Divisional officer of the area where the individual and / or his family normally resides.
- j. To avail the benefits of MSE under SC/ST category, the related documents as stated above should be submitted along with tender documents.
- k. Payment for MSE vendors will be as per MSMED Act, 2006.

5. RISK PURCHASE PENALTIES

- a. In case of delay in delivery beyond PO delivery /mutually agreed delivery, or vendor fails /refuses to complete the PO as per terms, or insufficient facilities at vendor's works to execute a PO, BHEL has the right to get the items ordered elsewhere at the risk and cost of the vendor with notice to the vendor and the additional expenditure / difference in cost, if any, including consequential cost shall be recovered from the defaulted vendor. Also, in such case of withdrawal of orders, BHEL shall recover the additional expenditure / difference from vendor by adjusting against amount due to vendor and/or by invoking the BG and/or by any other suitable means as decided by BHEL. In addition, BHEL may recover from the defaulter vendor any loss to BHEL arising due to withdrawal of orders in such case, and action shall be taken as per latest revision of BHEL Guidelines for Suspension of Business dealings with Suppliers / Contractors.
- b. BHEL has the right to divert/cancel the order if the vendor has not procured minimum 50% of the quantity of raw materials within 60 days from PO date. Purchase order placed on steel mills and with proper payment voucher/proof will be considered for not cancelling the PO by BHEL. The submission of data by vendor for DB clearance by BHEL/QC shall be the proof of procurement. This is to avoid delay in project schedule due to delay in raw material procurement by vendors. In case the vendor fails to procure at least 50% of the quantity of raw materials within 60 days from PO date, BHEL has the right to get the items ordered elsewhere at the risk and cost of the defaulting Vendor and the additional expenditure / difference in cost, if any, including consequential cost shall be recovered from the defaulting Vendor and action shall be taken as per latest revision of BHEL Guidelines for Suspension of Business dealings with Suppliers / Contractors and SEARP.



Maharatna Company

BHARAT HEAVY ELECTRICALS LTD

VALVES PURCHASE

Trichy - 620 014, India

GENERAL TERMS AND CONDITIONS

Enquiry Reference: **ENBPS02346**

- c. The defaulted vendor shall be liable for any loss, which BHEL may sustain by reason of such risk purchases in addition to liquidated damages as mentioned under LD clause.
- d. Vendors pending payments shall be withheld to cover the liabilities of BHEL towards risk purchase, if any.
- e. Reasons like power cut, labour issues, machine break down, etc. which are controllable by the sub-contractor shall not be accepted as reason for delay for delivery extension purposes.
- f. If PO delivery needs to be extended for reason attributable to BHEL, vendor may request BHEL in writing for delivery extension with justifications within 15 days from date of PO closure and before invoice.
- g. Process of calculating the risk and cost amount is as follows:

$$\text{Risk \& Cost Amount} = [(A-B) + (A \times H/100)]$$

Where,

A = Value of Balance scope of Work/ Supply (*) as per rates of new contract

B = Value of Balance scope of Work/ Supply (*) as per rates of old contract being paid to the contractor/ supplier at the time of termination of contract i.e. inclusive of PVC & ORC, if any.

H = Overhead Factor to be taken as 5

In case (A-B) is less than 0 (zero), value of (A-B) shall be taken as 0 (zero).

*(Balance scope of work/ supply)

Difference of Contract Quantities and Executed Quantities as on the date of issue of Letter for 'Termination of Contract', shall be taken as balance scope of Work/ Supply for calculating risk & cost amount. Contract quantities are the quantities as per original contract. If, Contract has been amended, quantities as per amended Contract shall be considered as Contract Quantities. Items for which total quantities to be executed have exceeded the Contract Quantities based on drawings issued to contractor from time to time till issue of Termination letter, then for these items total Quantities as per issued drawings would be deemed to be contract quantities. Substitute/ extra items whose rates have already been approved would form part of contract quantities for this purpose. Substitute/ extra items which have been executed but rates have not been approved, would also form part of contract quantities for this purpose and rates of such items shall be determined in line with contractual provisions. In-case portion of work is being withdrawn, contract quantities pertaining to portion of work withdrawn shall be considered as 'Balance scope of work/supply' for calculating Risk & Cost amount.

- h. Vendors are cautioned that, withdrawal after price bid opening or after contract signing or PO/LOI acceptance will be construed as tampering with BHEL's tender process. Suitable action for suspension of further business with the vendor may be taken as per BHEL corporate procedures.
- i. Abridged version of extant 'Guidelines for suspension of business dealings with suppliers/ contractors' has now been uploaded on www.bhel.com on "supplier registration page" at the following link: http://www.bhel.com/vender_registration/vender.php (Guidelines for suspension of business dealings with suppliers/ contractors).

6. GENERAL CONDITIONS

- a. The manner of finalization will be as mentioned in the "Confirmation to the Terms and Conditions" attached. Separate orders will be released for each project and documents should be supplied for each order separately.
- b. BHEL reserves the right to reduce the tender quantity and to NOT to order for some or all material based on the changes in project.
- c. BHEL shall have the right to visit vendor works during the execution of contract along with end customer for verifying status, inspection and testing of the material.
- d. BHEL reserves the right to negotiate or re-float the tender in case the quoted prices are not acceptable.
- e. Supplier shall arrange packing to avoid lose or damages during Road Transport, Site handling & Storage.
- f. BHEL reserves the right to reject the offer of a particular bidder due to unsatisfactory past performance in the execution of a contract at any of BHEL projects / units.
- g. The Drawings and Technical documents given in this enquiry are the sole property of BHEL. This should not be misused in any form.
- h. Purchase Order, PO Item serial number, Material code, Quantity should be clearly marked on the packing
- i. Confirmation for compliance is to be given in the offer for all the conditions specified above and to the respective Purchase Specification.



BHARAT HEAVY ELECTRICALS LTD

VALVES PURCHASE

Trichy - 620 014, India

GENERAL TERMS AND CONDITIONS

Enquiry Reference: **ENBPS02346**

- j. The bidder along with its associate/collaborators/sub-contractors/sub-vendors/consultants/service providers shall strictly adhere to BHEL fraud prevention policy (refer www.bhel.com) and shall immediately bring to the notice of the BHEL management about any fraud or suspected fraud as soon as it comes to their notice.
- k. For this procurement, Public Procurement (Preference to Make in India), Order 2017 dated 15.06.2017, 28.05.2018, 29.05.2019 and 04.06.2020, issued by DPIIT, Ministry of Commerce and Industry. If any subsequent Orders issued by the respective Nodal Ministry shall be applicable even if issued after issue of this NIT but before finalization of contract / PO / WO against this NIT. In the event of any Nodal Ministry prescribing higher or lower percentage of purchase and / or local content in respect of this procurement, same shall be applicable. Default purchase preference shall be 20% to local suppliers with default minimum local content of 50%.

7. DOCUMENTATION:

- a. **With Consignment:** Duplicate for transporter copy, Original Invoice, Packing List, Delivery Challan, O&M manual (if applicable) Material Test Certificate, Test Certificates, Compliance Certificate, Guarantee/Warranty Certificate and other documents mentioned in PO/TDC/Drawing.
- b. **To Purchase:**
 - i. FOR BHEL TRICHY case- Original Invoice, Duplicate for transporter copy, Packing list, LWB and Delivery challan, GST declaration as mentioned in point 3c.
 - ii. FOR Site case- Original Invoice, Original LWB, Original Packing List, Original IBR documents, Original despatch clearance Certificate and Inspection report, Test certificates as per PO, Original Site Acknowledgment etc.
- c. **Identification:** Material code, Purchase Order, PO item serial number, Unique serial number if any should be provided in all despatch documents, materials and packing clearly.

8. TENDER EVALUATION:

- a. **Techno-commercial Bid.**
 - i. All vendors should submit General arrangement drawing, datasheet and C&I diagram (if any) of the offered product
 - ii. Point by point technical confirmation of all pages of our technical specifications and commercial conditions are required with your sign and seal along with techno commercial offer.
 - iii. Offers from supplier not having technical capability or not agreed for commercial terms, will be rejected.
- b. **Price Bid.**
 - i. Bidders qualified for part I will be intimated for participating in priced bid opening.
 - ii. L1 bidder will be decided based on landed cost for the equipment to BHEL.

Indigenous Vendors

Total Landed cost/rate for each item = FOR Rate in INR (A) + Applicable Taxes (B) + Loading non-acceptance of commercial terms (C) – Applicable input tax credit (D)

A - Indigenous vendors submit offers on Free on Road (FOR), Stores, HPBP BHEL Trichy in INR.

B - Applicable GST and any other charges quoted by indigenous vendors will be added to the base price.

C - Loading for non-acceptance of payment terms, delivery schedule & liquidated damages (LD) will be added to the F.O.R. value for arriving the landed rate.

D - However, input tax credit shall be availed for GST, hence the same is excluded for arriving at the landed cost.

- iii. In case of tie for the L1 positions,
 - a. In the course of evaluation, if more than one bidder happens to occupy L1 status, effective L1 will be decided by soliciting discounts from respective L1 bidders.
 - b. In case more than one bidder happens to occupy the L1 status even after soliciting discounts, the L1 bidder shall be decided by a toss/draw of lots, in the presence of the respective L1 bidders(s) or their representative(s).
 - c. Ranking will be done accordingly, BHEL's decision in such situation shall be final and binding.



Maharatna Company

BHARAT HEAVY ELECTRICALS LTD

VALVES PURCHASE

Trichy - 620 014, India

GENERAL TERMS AND CONDITIONS

Enquiry Reference: **ENBPS02346**

Note:

All clarifications / issues shall be addressed directly to the tender issuing (procurement) department's officials whose contact details are provided below

(1)

S Suresh

Deputy Manager

Valves Purchase

24 Building, 3rd Floor,

BHEL, Trichy-620014

+91 431 2578668

suresh.s@bhel.in

(2)

Ajay Kumar Gupta

AGM

Valves Purchase

24 Building, 3rd Floor,

BHEL, Trichy-620014

+91 431 2578156

ajaykumar.gupta@bhel.in

2-V-0000-15483
DRAWING NO. ON REVERSE

ALL DIMENSIONS ARE IN MILLIMETRES. FOR TOLERANCES OF UNTOLERANCED DIMENSIONS DURING MANUFACTURE REFER RELEVANT QCP / QP

SL.No.	DRAWING No.	MATL. CODE	ØD ^{+2/0}	L ^{+4/0}	NET WT (Kg)	APPLICABLE VALVE SIZES
01	2-V-G041-15483/3	964530010000	92.5	30	0.24	65/1500 GL,RE
02	2-V-W049-15483/3	964530020000	98.5	30	0.27	65/1500 WG
03	2-V-W001-15483/3	964530030000	102.5	30	0.28	65/2500 WG,GL,RE,65/1500 NR
04	2-V-G004-15483/3	964530040000	106.5	40	0.35	65/3500 GL,80/1500 GL,RE
05	2-V-L161-15483/3	964530050000	112.5	40	0.38	80/1500 NR,65/2500 NR
06	2-V-G145-15483/3	964530060000	117.5	40	0.40	80/2500/ GL,80/1500 WG
07	2-V-W345-15483/3	964530070000	122.5	50	0.49	65/3500 RE,80/2500 WG
08	2-V-L025-15483/3	964530080000	127.5	40	0.45	80/3500 RE,80/2500 NR
09	2-V-G001-15483/3	964530090000	137.5	50	0.57	100/1500 RE,GL,WG,100/2500 RE,GL
10	2-V-L053-15483/3	964530100000	142.5	40	0.53	100/1500 NR
11	2-V-W369-15483/3	964530110000	147.5	40	0.56	80/3500 WG
12	2-V-W002-15483/3	964530120000	152.5	50	0.66	100/2500 WG,NR
13	2-V-W353-15483/3	964530130000	158	75	0.69	125/2500 WG
14	2-V-W441-15483/3	964530140000	163	50	0.73	125/1500 WG,RE
15	2-V-W065-15483/3	964530150000	188	75	1.13	150/2500 WG,NR
16	2-V-W057-15483/3	964530160000	193	75	1.17	150/1500 WG,NR
17	2-V-G002-15483/3	964530170000	205	75	1.28	150/2500 RE,GL
18	2-V-W113-15483/3	964530180000	238	75	1.58	200/1500 WG,NR
19	2-V-L002-15483/3	964530190000	243	100	1.93	200/2500 NR
20	2-V-W003-15483/3	964530200000	248	100	1.98	200/2500 WG
21	2-V-L177-15483/3	964530210000	287.5	100	2.43	250/2500 NR,WG,250/1500 WG
22	2-V-L129-15483/3	964530220000	293	100	2.50	250/1500 NR
23	2-V-W061-15483/3	964530230000	340	100	3.10	300/1500 WG,NR
24	2-V-W005-15483/3	964530240000	354.5	100	3.29	300/2500 WG,NR
25	2-V-W117-15483/3	964530250000	383	100	3.69	350/1500 WG
26	2-V-L121-15483/3	964530260000	393	100	3.84	350/1500 NR
27	2-V-W465-15483/3	964530270000	403	100	3.99	350/2000 WG
28	2-V-L029-15483/3	964530280000	418.5	100	4.22	300/2000 ELB,350/2500 NR
29	2-V-W006-15483/3	964530290000	423	150	5.33	350/2500 WG
30	2-V-L081-15483/3	964530300000	443	150	5.70	350/2500 SCH
31	2-V-L113-15483/3	964530310000	448	100	4.68	300/2000 ELB,350/2750 WG
32	2-V-W069-15483/3	964530320000	473	150	6.25	400/2500 WG
33	2-V-G137-15483/3	964530330000	482	150	6.43	400/2500 RE,18"/150C GV
34	2-V-W457-15483/3	964530340000	503	100	5.60	450/1500 WG
35	2-V-W073-15483/3	964530350000	533	175	8.10	450/2500 WG
36	2-V-W515-15483/3	964530360000	558	175	8.65	450/2000 WG
37	2-V-W417-15483/3	964530370000	613	150	9.17	600/1500 WG
38	2-V-W077-15483/2	964531150000	563	175	8.77	500/2750 WG
39	2-V-W505-15483/1	964531160000	197	75	1.21	150/2750 WG
40	2-V-L033-15483/3	964531740000	513	200	8.33	450/2500 SCH
41	2-V-L169-15483/2	964531750000	463	150	6.09	400/2500 SCH
42	2-V-W393-15483/2	964531760000	458	100	4.86	400/1500 WG
43	2-V-L089-15483/2	964531770000	168	80	1.02	125/1500 & 125/2500 SCH
44	2-V-W752-15483/2	964533550000	593	175	9.20	500/2850 SPL WG
45	2-V-W021-15483/2	964533590000	325	100	2.94	300/2500 WG (FOR P91)
46	2-V-K616-15483/4	964650090000	638	100	9.2	24"/150C GV
47	2-V-N589-15483/4	964650110000	372	100	3.4	14"/150C GV

SL.No.	DRAWING No.	MATL. CODE	ØD ^{+2/0}	L ^{+4/0}	NET WT (Kg)	APPLICABLE VALVE SIZES
48	2-V-N370-15483/4	964650100000	532	100	6.4	20"/150C GV
49	2-V-N594-15483/4	964650120000	440	100	4.4	16"/300C GV
50	2-V-3204-15483/2	964651370000	790	70	10.5	700MM/1500 RHID
51	2-V-P366-15483/2	964652090000	311	40	1.8	10"/C300-RV
52	2-V-WA81-15483/3	964660030000	685	200	12.6	550/3000 SPL GV
53	2-V-NG24-15483/2	964653650000	486	100	5.3	18/300-GV
54	2-V-3319-15483/2	964654100000	869	70	12.3	800/1500-RHID
55	2-V-P560-15483/2	964654140000	356	40	2.3	300/300-RV
56	2-V-3314-15483/2	964661000000	970	125	17.6	800/600-RHID
57	2-V-U482-15483/2	964661010000	882	110	14.6	700/1500-RHID
58	2-V-F999-15483/1	964655050000	1023	80	16.95	38"/600C GV,38"/300C SCV
59	2-V-L401-15483	964663610000	790	175	14.5	24"/C3000 NRV
60	2-V-V567-15483	964665240000	345	120	3.52	10"/C3500 GV
61	2-V-L420-15483	964665280000	179	45	0.82	4"/C3500 SCV
62	2-V-G371-15483	964665290000	212	40	0.71	6"/C3500 GLV
63	2-V-WD11-15483	964665300000	774	162	13.7	22"/C3500 GV
64	2-V-V396-15483	964665440000	519	200	8.5	450/C2500 GV
65	2-V-L435-15483/1	964665450000	638	190	11.01	22"/2500C NRV
66	2-V-G366-15483	964665470000	212	80	1.4	6"/3500C GNV
67	2-V-V730-15483	964665490000	695	185	12.4	22"/3500C GV
68	2-V-3394-15483	964665500000	902	125	12.78	32"/600C RHID
69	2-V-3311-15483/1	964658050000	812	150	14.20	30"/600C-RHID
70	2-V-G390-15483/1	964665520000	131	40	0.50	3"/3500C-GLV / GNV
71	2-V-NK44-15483	964659030000	760	45	8.89	28"/300C GV
72	2-V-U829-15483/1	964665530000	732	185	13.35	22"/3500C GV F92
73	2-V-3397-15483/1	964665540000	756	140	12.32	28"/900C RHID F92
74	2-V-V771-15483/1	964665560000	802	300	19.88	22"/C3750C GV
75	2-V-V711-15483/1	964665570000	184	75	1.12	6"/900C GV
76	2-V-3369-15483/1	964659160000	958	175	19.7	36"/600C RHID
77	2-V-V768-15483/1	964665580000	254	80	1.82	6"/1500C GV F92
78	2-V-V756-15483	964665590000	222	80	1.50	6"/3500C GV F92
79	2-V-NK85-15483	964659170000	812	100	12.2	28"/300C GV WCB
80	2-V-G402-15483	964665600000	229	80	1.57	6"/3750C GLV / GNV
81	2-V-V772-15483	964665610000	280	95	2.30	8"/3000C GV
82	2-V-V780-15483	964665620000	754	300	18.24	22"/C3650C GV
83	2-V-L442-15483	964665640000	368	100	3.51	12"/C2750C SCV

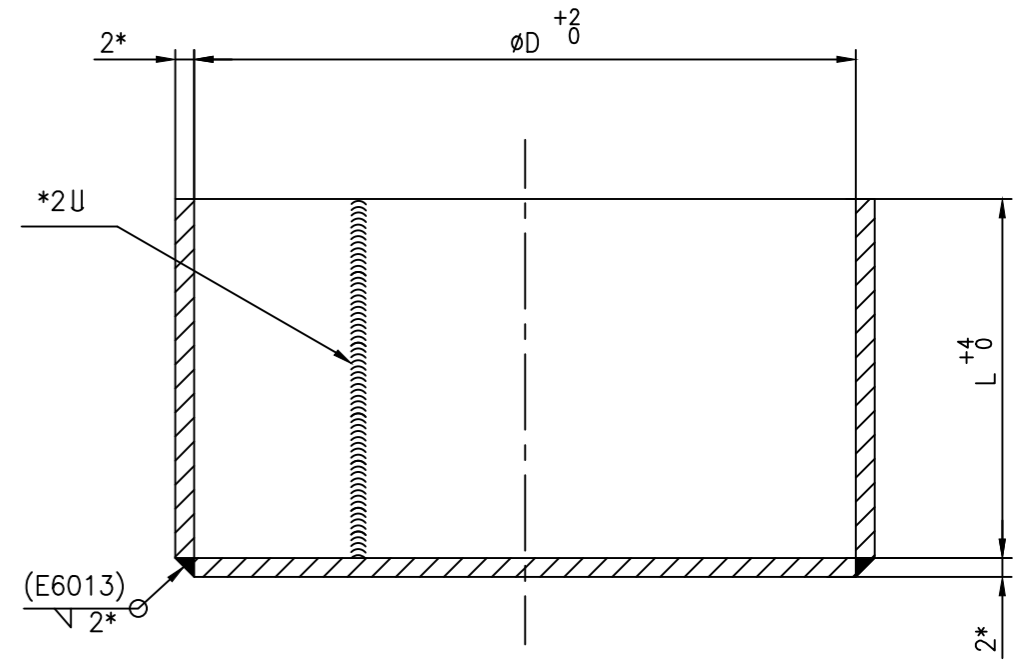

NOTE:
1. MATERIAL SPECIFICATION: IS 1079 HR1
2. *SHEET THICKNESS 1.6 ALSO ACCEPTABLE.

REV	DATE	ALTERED	R.P.SINGH	REV	DATE	ALTERED	R.P.SINGH
		CHD & APPD		43	29.12.20	CHD & APPD	SAMEER & SSK
							S.No. 83 INCLUDED.
42	12.10.20	CHD & APPD	SAMEER & SSK	41	04.09.20	CHD & APPD	SAMEER & SSK
							S.No. 82 INCLUDED.

CAUTION: The information on this document is the property of BHARAT HEAVY ELECTRICALS LTD. It must not be used directly or indirectly in any way detrimental to the interest of the company.

No OFF	DESCRIPTION	MATL CODE	MATL SPECN	HEAT TREATMENT	SCRAP SORT	NET WT (kg)	GROSS WT (kg)	DRAWING No	ITEM No	
TYPE OF PRODUCT OR NAME OF CUSTOMER/PROJECT										
BHARAT HEAVY ELECTRICALS LTD. UNIT: HIGH PRESSURE BOILER PLANT. TIRUCHIRAPALLI - 620014.						DRN	V.BAIRAVAN	SIGN	DATE 05.08.15	NO.OF VAR.
						CHD	S.SATHEES		05.08.15	
						APPD	K.RAJASEKARAN		05.08.15	
DEPT	VL	SCALE	WEIGHT (KG).	REFERENCE INFORMATIONS			NO. OF ITEMS			
CODE 320		NTS	REF. TABLE							
TITLE							CARD CODE	DRAWING NO.	REV	
METALLIC END COVERS (FABRICATED)							U 01	2-V-0000-15483	43	

3-V-0000-22267
DRAWING NO

ALL DIMENSIONS ARE IN MILLIMETERS FOR TOLERANCES OF UNTOLERANCED DIMENSIONS DURING MANUFACTURE REFER RELEVANT QCP/QP

SL. NO	DRAWING NO	MATL CODE	$\phi D \begin{smallmatrix} +2 \\ 0 \end{smallmatrix}$	$L \begin{smallmatrix} +4 \\ 0 \end{smallmatrix}$	WEIGHT	SIZE
01	3-V-L915-22267/1	964605530000	236	83	1.65	8"/300C
02	3-V-L929-22267/1	964605540000	343	83	2.5	12"/150C
03	3-V-L943-22267/1	964605550000	432	83	4.07	16"/150C
04	3-V-L957-22267/1	964605560000	646	83	7.78	24"/150C
05	3-V-L820-22267/1	964605570000	533	100	6.13	18"/600C
06	3-V-L825-22267/1	964605580000	187	53	0.92	6"/300C
07	3-V-L841-22267/1	964605590000	297	53	1.82	10"/300C
08	3-V-L857-22267/1	964605600000	352	53	2.44	12"/300C
09	3-V-L873-22267/1	964605610000	192	53	0.96	6"/600C
10	3-V-L889-22267/1	964605620000	397	53	2.98	14"/600C
11	3-V-L893-22267/1	964606420000	358	53	2.6	14"/150C(REDCER)
12	3-V-L805-22267/1	964606430000	459	100	5.9	18"/150REDUCER
13	3-V-L890-22267/1	964606520000	561	70	5.825	22"/18"REDUCER
14	3-V-L891-22267/1	964606530000	408	25	2.555	16"/18"REDUCER
15	3-V-L725-22267/1	964606540000	573	50	5.467	20"/300C
16	3-V-L751-22267/1	964606550000	713	70	8.737	28"/26"REDUCER
17	3-V-L752-22267/1	964606560000	702	75	8.681	24"/600C
18	3-V-L984-22267/1	964606570000	385	40	2.591	16"/300C
19	3-V-L783-22267/1	964606580000	430	85	4.09	16"/600C
20	3-V-L793-22267/1	964606980000	934	100	15.3	32"/600C
21	3-V-L789-22267/1	964606990000	854	100	13.1	32"/150C
22	3-V-L507-22267/1	964607450000	319	60	2.3	10"/600C
23	3-V-L508-22267/1	964607460000	221	30	1.0	8"X10"REDUCER
24	3-V-L794-22267/1	964607930000	944	150	19.5	32"/600C
25	3-V-L985-22267/1	964608140000	390	40	2.68	16"/300C
26	3-V-LA41-22267/1	964620310000	950	150	19	32"/900C
27	3-V-LB72-22267/1	964620710000	995	150	19.5	34"/600C
28	3-V-LC67-22267	964621530000	768	90	9.5	28"/150/300C

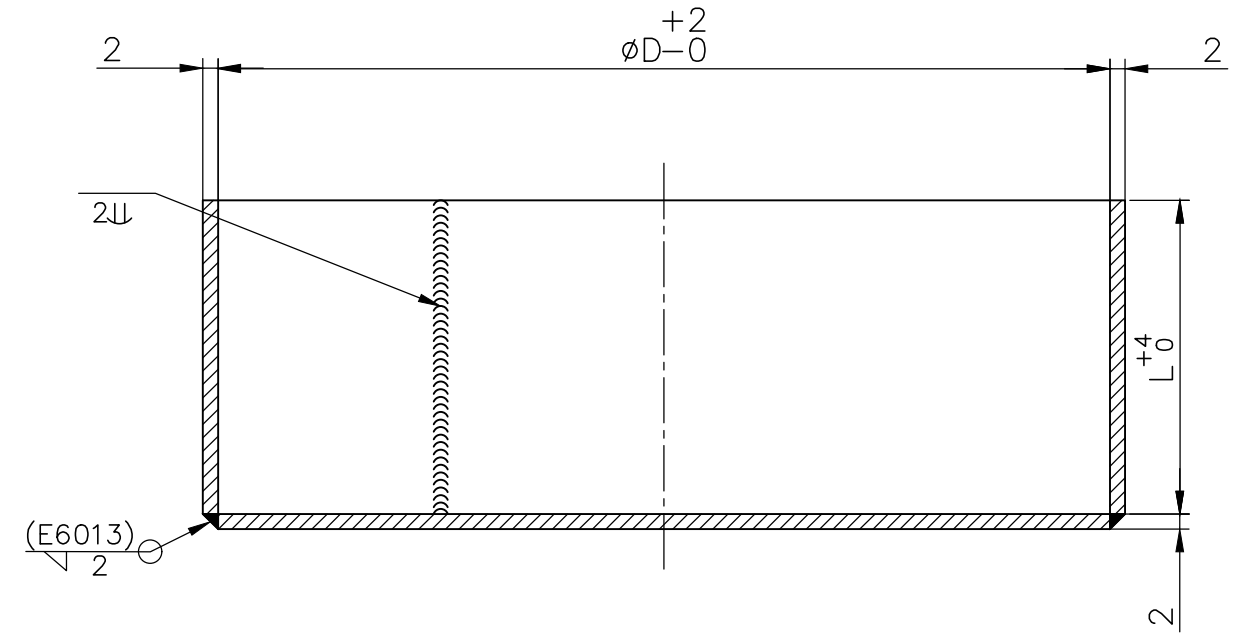

NOTE:

MATERIAL SPECIFICATION:- IS 1079 HR1

REV	DATE	ALTERED	JALAL	REV	DATE	ALTERED	M.S.SELVAM
11	21.06.19	CHD & APPD	KAVITHA	10	16.07.15	CHD & APPD	MS & SSK
S.No. 28 ADDED				MATERIAL IS 1079 HR1 WAS IS 1079 Gr. ST 34 DCP : 801963			

CAUTION: The information on this document is the property of BHARAT HEAVY ELECTRICALS LTD. It must not be used directly or indirectly in any way detrimental to the interest of the company.

NO OFF	DESCRIPTION	MATL CODE	MATL SPECN	HEAT TREATMENT	SCRAP SORT	NET WT (kg)	GROSS WT (kg)	DRAWING No	ITEM No	
TYPE OF PRODUCT OR NAME OF CUSTOMER/PROJECT										
BHARAT HEAVY ELECTRICALS LTD., UNIT: HIGH PRESSURE BOILER PLANT. TIRUCHIRAPALLI -620014.						DRN	NAME YUVA	SIGN YUVA	DATE 23.02.05	NO.OF VAR.
						CHD	PRK	PRK	23.02.05	
						APPD	SNR	SNR	23.02.05	
DEPT VL	SCALE NTS		WEIGHT (KG) ---		REFERENCE INFORMATIONS				NO. OF ITEMS	
CODE 320	TITLE METALLIC END COVERS (FABRICATED)		CARD CODE U 01	DRAWING NO. 3-V-0000-22267				REV 11		

3-V-0000-23461

DRAWING NO.



SL. NO.	DRAWING NO.	COMPONENT CODE	ϕD^0	L^0	WT (kg)	VALVE SIZE
01	3-V-N590-23461/2	964536440000	426	100	4.4	16"-150C
02	3-V-N593-23461/2	964536450000	387	90	3.6	14"-300C
03	3-V-N595-23461/2	964536460000	542	125	7.0	20"-300C
04	3-V-V137-23461/2	964535420000	359	100	4.0	300/1500C
05	3-V-V329-23461/2	964535430000	304	100	2.7	250/2500C
06	3-V-V465-23461/2	964535440000	545	200	5.4	500/3500C
07	3-V-C520-23461/2	964536900000	84	30	0.3	65/1500C
08	3-V-C524-23461/2	964536910000	184	75	1.1	150/1500C
09	3-V-C526-23461/2	964536920000	234	75	1.6	200/1500C
10	3-V-N826-23461/3	964650010000	850	90	12.4	32"/150C
11	3-V-W587-23461/2	964535770000	256	100	2.05	200/2750C
12	3-V-W551-23461/2	964535890000	408	50	3.06	500/2750C
13	3-V-V377-23461/2	964535910000	466	150	6.13	350/2500&400/2500
14	3-V-3318-23461/2	964653630000	827	80	11.6	700/1500
15	3-V-LA44-23461/1	964620330000	262	30	1.26	200/C900

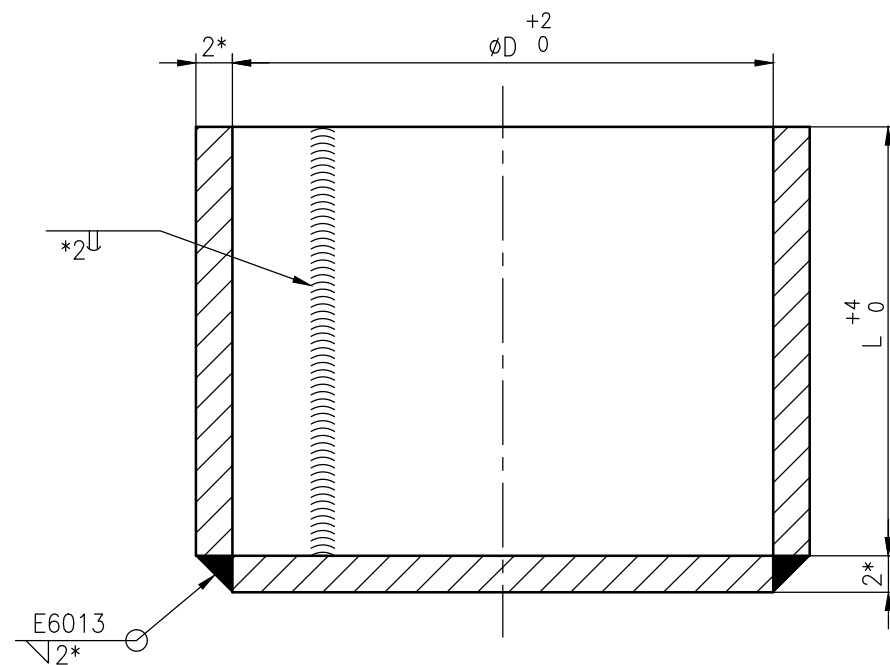

NOTE:-

- 1.MATERIAL SPECIFICATION :- IS1079 HR1
2. *SHEET THICKNESS 1.6 ALSO ACCEPTABLE.

REV	DATE	ALTERED	M.S.SELVAM	REV	DATE	ALTERED	JALAL
10	16.07.15	CHD & APPD	MS & SSK	9	16.07.13	CHD & APPD	ATHIANNAVI
MATERIAL IS 1079 HR1 WAS IS 1079 Gr. ST 34				SL. No.15 INCLUDED.			
DCP : 801963							

CAUTION: The information on this document is the property of BHARAT HEAVY ELECTRICALS LTD. It must not be used directly or indirectly in any way detrimental to the interest of the company.

SL No	DRAWING No	COMP CODE	MATL SPECN	HEATTREATMENT	SCRAP SORT	NET WT (kg)	GROSS WT (kg)
-	-	-	-	-	-	-	-
TYPE OF PRODUCT OR NAME OF CUSTOMER/PROJECT							
BHARAT HEAVY ELECTRICALS LTD., UNIT: HIGH PRESSURE BOILER PLANT. TIRUCHIRAPALLI-620014.				DRN	V.BAIRAVAN	SIGN	DATE 24.12.04
				CHD	K.RAJASEKARAN		DATE 24.12.04
				APPD	M.RAJAKUMAR		DATE 24.12.04
DEPT	VL	SCALE	WEIGHT (KG).	REFERENCE INFORMATION			NO. OF ITEMS
CODE	320	N T S	REF.TABLE	CAD REF:C323461			
TITLE				CARD CODE	DRAWING NO.		REV
METALLIC END COVERS (FABRICATED)				U 01	3-V-0000-23461		10

Sl. No.	DRAWING NUMBER	COMPONENT CODE	MATERIAL	HEAT TREATMENT	DIMENSIONS			WEIGHT IN KGS.
					φ D	φ D1		
01.	3-V-5903-06545	96 452 862	BS 970 EN 42	HEAT TREATED TO HARDNESS 50 HRC	22.2	14.35		0.01
02.	3-V-5913-06545	96 452 863			20.6	16.67		0.01
03.	3-V-5904-06545	96 452 864			26.6	17.55		0.01
04.	3-V-5914-06545	96 452 865			25.4	20.63		0.01
05.	3-V-5906-06545	96 452 866			39.7	22.30		0.01
06.	3-V-5916-06545	96 452 867			33.3	26.60		0.01
07.	3-V-5907-06545	96 452 868			44.5	25.48		0.01
08.	3-V-5917-06545	96 452 869			38.1	29.80		0.01

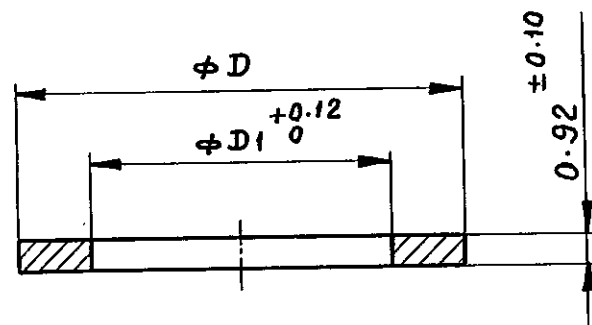

6.3 /

NOTES

1. BREAK ALL SHARP CORNERS.

NO. OF PIECES	DESCRIPTION	SEM PRO. SEQ. NO.	INT. MAT. / SEQ. NO.	FINAL MATERIAL	SCRAP SORT	NET WI (kg)	GROSS (wt) kg	DRAWING NO.	ITEM NO.
---------------	-------------	-------------------	----------------------	----------------	------------	-------------	---------------	-------------	----------

BHARAT HEAVY ELECTRICALS LTD.,
BOILER PLANT UNIT, TIRUCHIRAPALLI-14

FIRST ANGLE	SCALE	DRAWN	TOTAL NET WT. (kg)
	NTS		TYPE
ALL DIMENSIONS IN MILLIMETRES		DATE	NEW/OLD DRG. NO.
		05.07.88	

CAUTION
 THE INFORMATION CONTAINED IN THIS DRAWING IS THE PROPERTY OF BHARAT HEAVY ELECTRICALS LTD., BOILER PLANT UNIT, TIRUCHY-14 AND SHALL NOT BE USED WITHOUT THEIR EXPRESS WRITTEN PERMISSION IN ANY FORM OR PART THEREOF FOR ANY OTHER PURPOSE THAN FOR WHICH IT IS SENT TO YOU.

33-115

WASHER

DRAWING NO: **3-V-0000-06545**

REVISION

REV	DATE	ALTERED
		CHECKED SAPPD
ZONE		