

TECHNICAL QUALIFICATION REQUIREMENT

Name of Project: 400/220 kV GIS SUB STATION AT ERSAMA, PARADEEP, ODISHA

Name of Customer: ODISHA POWER TRANSMISSION CORPORATION LIMITED

Name of Item: 220V LEAD ACID PLANTE TYPE BATTERY BANK

TECHNICAL QUALIFICATION REQUIREMENT

The bidder should have designed, manufactured, tested and supplied at least (2) nos of Battery Banks which should be in successful operation as on scheduled date of bid opening.

SUPPORTING DOCUMENTS TO BE SUBMITTED BY BIDDER ALONG WITH TECHNICAL BID

Sr	Required Criteria	Supporting Documents
1	Manufacturing	Approved Drawings / GTP / Approved Quality Plan / Factory Inspection Test Report etc. stabilising bidder as manufacturer of offered item in line with TQR
2	Supply	PO / Dispatch clearance / LR / Material Receipt certificate at site / installation or commissioning certificate etc. stabilising bidder as proven supplier of offered item in line with TQR
3	Type Test	TTR approval from customer / Type Test Report etc. stabilising successful type tested design in line with TQR
4	Commissioning	Pre commissioning report / commissioning report / Site Visit report issued by employer/end-customer or main contractor (along with chain of document from employer/end-customer) stating supervision of commissioning or pre-commissioning by bidder etc.
5	Successful operation	Successful operation means certificate issued by employer/end-customer or main contractor (along with chain of document from employer/end-customer) stating successful operation without any adverse remark.

NOTES:

1. Bidder to please note that the submitted bid shall be liable to rejection in the absence of submission of valid Technical TQR documents along with technical bid.
2. Consideration of offer shall be subject to customer's approval of bidder's, if applicable.
3. Notwithstanding anything stated above, BHEL reserves the right to assess the capabilities and capacity of the bidder to perform the contract, should the circumstances warrant such assessment in the overall interest of BHEL.
4. After satisfactory fulfilment of all the above criteria / requirement, offer shall be considered for further evaluation as per NIT and all the other terms of the tender.

Abhi Desh
19/05/23
PREPARED BY

BHEL
19/05/2023
REVIEWED BY

BHEL
19/05/2023
APPROVED BY



BHARAT HEAVY ELECTRICALS LIMITED
TRANSMISSION BUSINESS ENGINEERING MANAGEMENT
NOIDA

<p align="center">Copyright & Confidential</p> <p align="center">The information in this document is the property of BHARAT HEAVY ELECTRICALS LIMITED This must not be used directly or indirectly in anyway detrimental to the interest of the company.</p>	DOCUMENT NO.	TB-420-316-025A	REV 00	Prepared	Checked	Approved
	TYPE OF DOC.	TECHNICAL SPECIFICATION	NAME	AK	DKS	VK
	Title: 220V, 645 AH, Plante Type Battery Bank along with accessories	SIGN				
		DATE	18.05.23	19.05.23	19.05.23	
		GROUP	TBEM			
WO No.	-					
CUSTOMER	ODISHA POWER TRANSMISSION CORPORATION LIMITED					
PROJECT	400/220 kV GIS SUB STATION AT ERSAMA, PARADEEP, ODISHA					
Contents						
Section No.	Description					No of Pages
Section-1	Scope, Project specific technical requirements & Bill of Quantities					06 + 03
Section-2	Equipment Specification under scope of supplies/ service					01 + 10
Section-3	Project details and general technical requirements (For all equipment under the Project)					46
Section-4	Annexures Annexure-A: Compliance Certificate to Technical Specification Annexure-B: Deviation(s) to Technical Specification Annexure-C: Guaranteed Technical Particulars Annexure-D: Technical Checklist					07
<p>Remarks: Bidder to note that data and details of Annexure-C (Guaranteed Technical Particulars) shall not be reviewed during technical evaluation/ scrutiny, hence compliance of guaranteed technical particulars in line with technical specification shall be bidder's responsibility.</p>						
Rev. No.	Date	Altered	Checked	Approved		
Distribution				To		
				Copies		

CHECKLIST FOR TECHNICAL EVALUATION

Along with the technical offer/ bids, the bidder should submit this checklist confirming the inclusion of the enclosures as listed below,

Sl. No.	Documents to be enclosed	Bidder to confirm (Please tick "Confirmed")
1.	Supporting documents for compliance of Technical Qualifying Requirement.	Confirmed
2.	Unpriced BOQ duly mentioning "Quoted" for all the items, signed and sealed.	Confirmed
3.	Annexure- A duly signed and sealed & Annexure- B duly filled, signed and sealed.	Confirmed

Note: Any bidder not meeting the above requirement shall be liable for non-evaluation. The above checklist is reviewed and verified for,

NIT Reference No.:

Name of Bidder:

Name of Project: 400/220 kV GIS SUB STATION AT ERSAMA, PARADEEP, ODISHA

Date:

Bidder's Stamp & Signature

Bharat Heavy Electricals Limited

Project: 400/220 kV GIS SUB STATION AT ERSAMA, PARADEEP, ODISHA

Technical Specification: 220V Lead Acid Plante type Battery Bank along with accessories

Doc No. TB-420-316-025A **Rev** 00

Contents

SECTION 1:	2
SCOPE, PROJECT SPECIFIC TECHNICAL REQUIREMENTS & BILL OF QUANTITIES	2
1. Scope	2
2. Specific Technical Requirements	2
3. Bill of Quantities	3
4. Drawings / Documents required for Technical Clearance for Manufacturing	5
5. Type Testing	5
6. Quality Plan	6
7. Inspection & Testing	6
8. Packing and Dispatch	6
9. List of Documents/ Drawings	6

Bharat Heavy Electricals Limited

Project: 400/220 kV GIS SUB STATION AT ERSAMA, PARADEEP, ODISHA

Technical Specification: 220V Lead Acid Plante type Battery Bank along with accessories

Doc No. TB-420-316-025A **Rev** 00

SECTION 1:

SCOPE, PROJECT SPECIFIC TECHNICAL REQUIREMENTS & BILL OF QUANTITIES

1. Scope

This technical specification covers the requirements of design, manufacturing, testing at works, packing and dispatch to site & supervision of Erection, testing & commissioning of 220V DC Lead acid Plante type Batteries complete with rack assembly and other accessories as required for trouble free operation of batteries.

This section covers the specific technical requirements of 220V Batteries. In case of any discrepancies between the requirements mentioned in this section and those specified in other sections of the specification, the specifications given herein shall prevail and shall be treated as binding requirements.

No deviation from the requirements specified in various clauses of this specification shall be allowed. A certificate to this effect shall have to be furnished along with the offer.

The equipment is required for the following project:

Name of the Customer : **ODISHA POWER TRANSMISSION CORPORATION LIMITED**
Name of Main Contractor : **Bharat Heavy Electricals Limited**
Name of the Project : **400/220 kV GIS SUB STATION AT ERSAMA, PARADEEP, ODISHA**

The scope of supplies shall be as per commercial terms and conditions enclosed separately with the notice inviting tender/ enquiry.

2. Specific Technical Requirements

1. The equipment (**220V Lead Acid Plante Storage Battery**) shall perform satisfactorily under various other electrical, electromechanical and meteorological conditions of the site of installation.
2. Equipment shall be able to withstand all external and internal mechanical, thermal and electromechanical forces due to various factors like wind load, temperature variation, ice & snow, (wherever applicable) short circuit etc. for the equipment.
3. In addition to this, the other specific technical requirements for the equipment (**220V Lead Acid Plante Storage Battery**) shall be as follows,

Parameter	220V DC
Nominal Voltage Rating	220V DC
Capacity	645 AH
Maximum Battery Bank Voltage	237.5
Minimum Battery Bank Voltage	198
Cell Float Voltage(Volt)	As per Manufacturer standard for float application
End Cell Voltage (ECV)	1.85V/ cell

Bharat Heavy Electricals Limited

Project: 400/220 kV GIS SUB STATION AT ERSAMA, PARADEEP, ODISHA

Technical Specification: 220V Lead Acid Plante type Battery Bank along with accessories

Doc No. TB-420-316-025A **Rev** 00

Electrolyte Specific gravity (at 27°C)	1.2
Cell designation	Stationary Lead Acid Plante Positive Plate High Discharge Type
Charging method	Float Charging during normal conditions and Boost charging of battery after emergency duty. The Battery shall float across charger through a suitable tap during Boost charging.
No. of Cells per battery	As per requirement to meet the technical Specification
Battery Room Size	Room Size as per enclosed Control Room Building drawing (Annexures of Section-1), bidder to confirm that offered battery banks can be suitably accommodated in room size with 1.0 meter clear space from inside wall surface.

3. Bill of Quantities

3.1 Main Items

Quantities for the equipment shall be as mentioned below. However, any item not appearing herein but required for completeness of the work and mentioned elsewhere is deemed to be included in bidder's scope.

Sl. No.	Description	Unit	Quantity
A.	Supply Item		
1	220V DC, 645 AH, Lead Acid Plante Type Battery Bank along with fittings & accessories complete in all respects. (Accessories are mentioned in clause no. 3.2 below)	Set	2
B.	Service		
1	Supervision of installation, testing & commissioning of 220V battery bank System	Set	2

Notes:

1. Though Battery Capacity is mentioned in the specification, however bidder shall submit Sizing calculations to finalise the no. of cells in battery bank. This calculation will be submitted to customer for approval and no price implication will be acceptable later.

3.2 Accessories

Each Battery Bank set comprises of following accessories listed below and will be furnished as part of each battery set. Price of the battery quoted in item Sl. No. A1 shall be inclusive of these items.

Bharat Heavy Electricals Limited

Project: 400/220 kV GIS SUB STATION AT ERSAMA, PARADEEP, ODISHA

Technical Specification: 220V Lead Acid Plante type Battery Bank along with accessories

Doc No. TB-420-316-025A **Rev** 00

Sl. No.	Description	Unit	Quantity (Per battery bank)
1	Teak wood racks with three coats of anti-acid paint and flame-proof coating.	Set	1
2	Stand insulators + 5% extra	Set	1
3	Cell insulators + 5% extra	Set	1
4	All Cell interconnectors and end take-offs	Set	1
5	Lead coated connection hardware such as bolts nuts etc + 5% extra or any other connector suitable for Battery	Set	1
6	Cell numbering tags with fixing arrangement	Set	1
7	Teakwood, cable clamps with hardware	Set	1
8	Diluted sulfuric acid of sufficient quantity and of specific gravity according to the relevant IS and 10% extra supplied in non-returnable, suitably packed, acid proof containers	Set	1
9	Cell testing center zero voltmeters 3-0-3 volts range. Accuracy class 05 or better and resistance not less than 1000 ohms	Nos.	2
10	Syringe type hydrometer complete with accessories and suitable for measuring SP gravity between 11 to 1 320 with graduation of 0.005 Sp. Gravity together with temperature correction charts	No.	1
11	Floating hydrometer	No.	1
12	Thermo-meters having range 0-100 deg C whose one division of the graduated scale shall represent at the most 1 degree centigrade with separate gravity correction chart. [Accuracy of calibration shall not be less than 0.5 degree C]	Nos.	2
14	Wall mounting teak-wood for hydrometers and thermo-meters	Set	1
15	Acid-resisting plastic jugs [2 litre capacity]	Nos.	2
16	Plastic funnels	Nos.	2
17	Rubber syphone	Nos.	2
18	Rubber aprons	Nos.	2
19	Rubber gloves	Pairs	2
20	Rubber boots - knee height	Pairs	2
21	Special tool's or tools required for connecting the terminals of the batteries	Set	2
22	The battery terminals shall be brought out in a junction box to be mounted on the battery stands	Set	1
23	Ampere-hour meter [10 hour discharge rate] of 600-1250 AH range	No.	1

Bharat Heavy Electricals Limited

Project: 400/220 kV GIS SUB STATION AT ERSAMA, PARADEEP, ODISHA

Technical Specification: 220V Lead Acid Plante type Battery Bank along with accessories

Doc No. TB-420-316-025A Rev 00

24	Any other accessories not specified but required for installation satisfactory operation and maintenance of batteries for a period of 5 [five] years	Set	1
----	--	-----	---

Notes:

1. Not Applicable/Not quoted as per bidder's design /confirmation. However, If found applicable later on, the same shall be deemed to be included in the scope of bidder and shall be supplied free of cost by bidder.

4. Drawings / Documents required for Technical Clearance for Manufacturing

The engineering drawings/ documents, shall be used for providing technical clearance for manufacturing of the equipment, which shall be used for delay analysis, if applicable.

1	220 V Battery Bank - Drawings & Guaranteed Technical Particulars
2	220 V Battery Bank - Type Test Reports
3	220 V Battery Bank - Quality Assurance Plan

Date of Submission of drawings/ documents shall be counted only from the date of submission of reasonably correct drawings/ documents. In case drawing/ document are not duly stamped in category-1/ category-2 by customer, BHEL stamp/ confirmation shall be treated final to proceed further.

The successful bidder shall have to extend all possible supports like timely submission/ re-submission of drawings, visit to end customer to facilitate documents approval without any commercial implications to BHEL. Acceptance of bidder's documents shall be subject to end customer/ OPTCL approval.

5. Type Testing

- 5.1 The 220V DC Lead acid plante type Batteries to be supplied shall be of type tested design. During detail engineering, the bidder shall submit for Owner's approval the reports of all the type tests as listed in this specification and carried out within last five years from the date of techno-commercial bid opening i.e. **11-Feb-2022**. These reports should be for the test conducted on the equipment similar to those proposed to be supplied under this contract and the test(s) should have been either conducted at an independent laboratory or should have been witnessed by a client.

Please refer clause no. A18.1 of Section-II for customer specific requirement of Type Test reports. Bidder to submit duly signed & stamped Annexure: IV-A & Annexure: V-A enclosed with Section-2

- 5.2 However, if the bidder is not able to submit reports of the type test(s) conducted within last five years from the date of techno-commercial bid opening, or in the case of type test report(s) are not found to be meeting the specification requirements, the bidder shall conduct all such tests under this contract at no additional cost to the BHEL either at third party lab or in presence of client/owners representative and submit the reports for approval.

Bharat Heavy Electricals Limited

Project: 400/220 kV GIS SUB STATION AT ERSAMA, PARADEEP, ODISHA

Technical Specification: 220V Lead Acid Plante type Battery Bank along with accessories

Doc No. TB-420-316-025A Rev 00

5.3 All acceptance and routine tests as per the specification and relevant standards shall be carried out. Charges for these shall be deemed to be included in the equipment price.

6. Quality Plan

The successful bidder shall submit Quality Assurance Plan including in-process inspection methods, tests, records, etc. for BHEL/ OPTCL approval. Customer hold points will also be included in the plan, which shall be mutually agreed by the BHEL/ OPTCL. In case bidder has reference Quality Assurance Plan agreed with BHEL/ OPTCL, same shall be submitted for specific project to BHEL/ OPTCL approval. There shall be no commercial implication to BHEL/ OPTCL on account of Quality Plan approval.

Bidder has to follow OPTCL approved Manufacturing Quality Plan, SAT/ FAT procedure at contract stage.

7. Inspection & Testing

1. Equipment shall be subject to inspection by BHEL/OPTCL or authorized representative at bidder/ manufacturers' works. Hence, Bidder shall furnish all necessary information concerning the supply to BHEL/ OPTCL.
2. Routine and acceptance tests as listed in relevant standard and section-2, technical specifications shall be complied.
3. Bidder shall also furnish factory acceptance test (FAT) from manufacturers for BHEL/ OPTCL approval in line with specific requirements mentioned in section-2, technical specification.

8. Packing and Dispatch

1. The equipment shall be properly packed for selected mode of transportation i.e. sea, rail and road in such a manner that it is protected against the climatic conditions and for any damage during transportation, transit and storage. Crates/ cases shall have skid bottoms for handling. Special notations such as 'Fragile', 'This side up', 'Weight', 'Owner's particulars\ 'PO nos.' etc., shall be clearly marked on the package together with other details as per purchase order.
2. The equipment may be stored outdoors for long periods before installation. The packing should also be suitable for outdoor storage areas with heavy rains/ high ambient temperature unless otherwise agreed and hence, Packing shall be suitable for long storage (minimum 1 year).

9. List of Documents/ Drawings

Following drawing/ documents are attached for information purpose,

1. TB-1-420-607-700/701/703: CONTROL ROOM BUILDING-FLOOR PLANS & SECTIONS

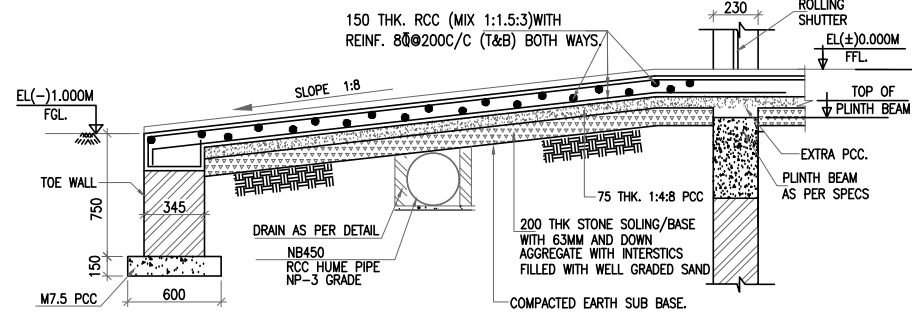

DETAIL OF RAMP

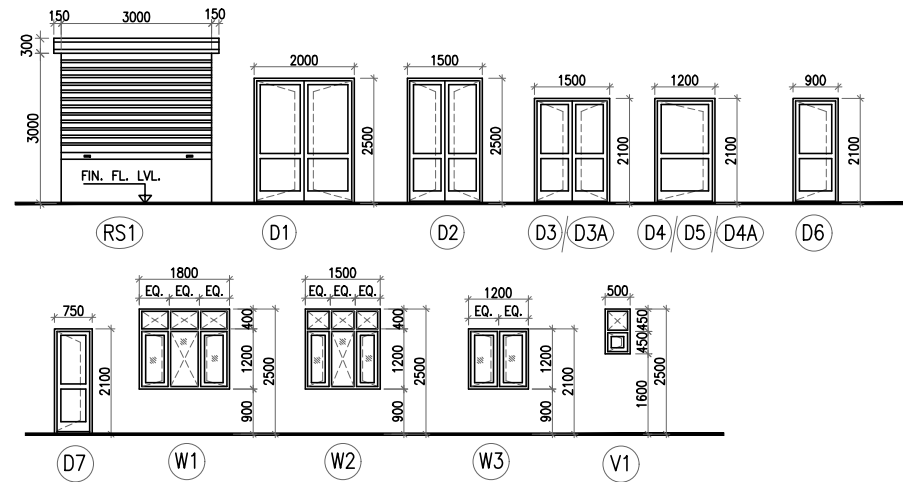

SCHEDULE OF DOORS & WINDOWS							
TYPE	OPENING SIZE	FRAME SIZE	ILL LEVEL	LINTEL LEVEL	NOS. (GR. FL.)	NOS. (FIRST+ TERRACE FL.)	DESCRIPTION
RS1	3000x3000	3000x3000	-	3000	1	-	
D1	2000x2500	1980x2490	-	2500	1	-	
D2	1500x2500	1480x2490	-	2500	2	1	
D3	1500x2100	1380x2090	-	2100	3	-	
D3A	1500x2100	1380x2090	-	2100	-	1	
D4	1200x2100	1180x2090	-	2100	-	6+1=7	
D4A	1200x2100	1180x2090	-	2100	-	1	
D5	1200x2100	1180x2090	-	2100	1	1	
D6	900x2100	880x2090	-	2100	4	4	
D7	750x2100	730x2090	-	2100	1	4	
W1	1800x1600	1780x1580	900	2500	11	6	
W2	1500x1600	1480x1580	900	2500	2	6	
W3	1200x1200	1180x1180	900	2100	-	2	
V1	500x900	480x880	1600	2500	4	7	
FG1	7400x1900	7380x1880	600	2500	-	1	
FG1	4900x1900	4880x1880	600	2500	-	1	
FG2	1590x1900	1570x1880	600	2500	-	1	

SEPARATE DRAWING SHALL BE REFERRED FOR DOOR/WINDOW DETAILS.

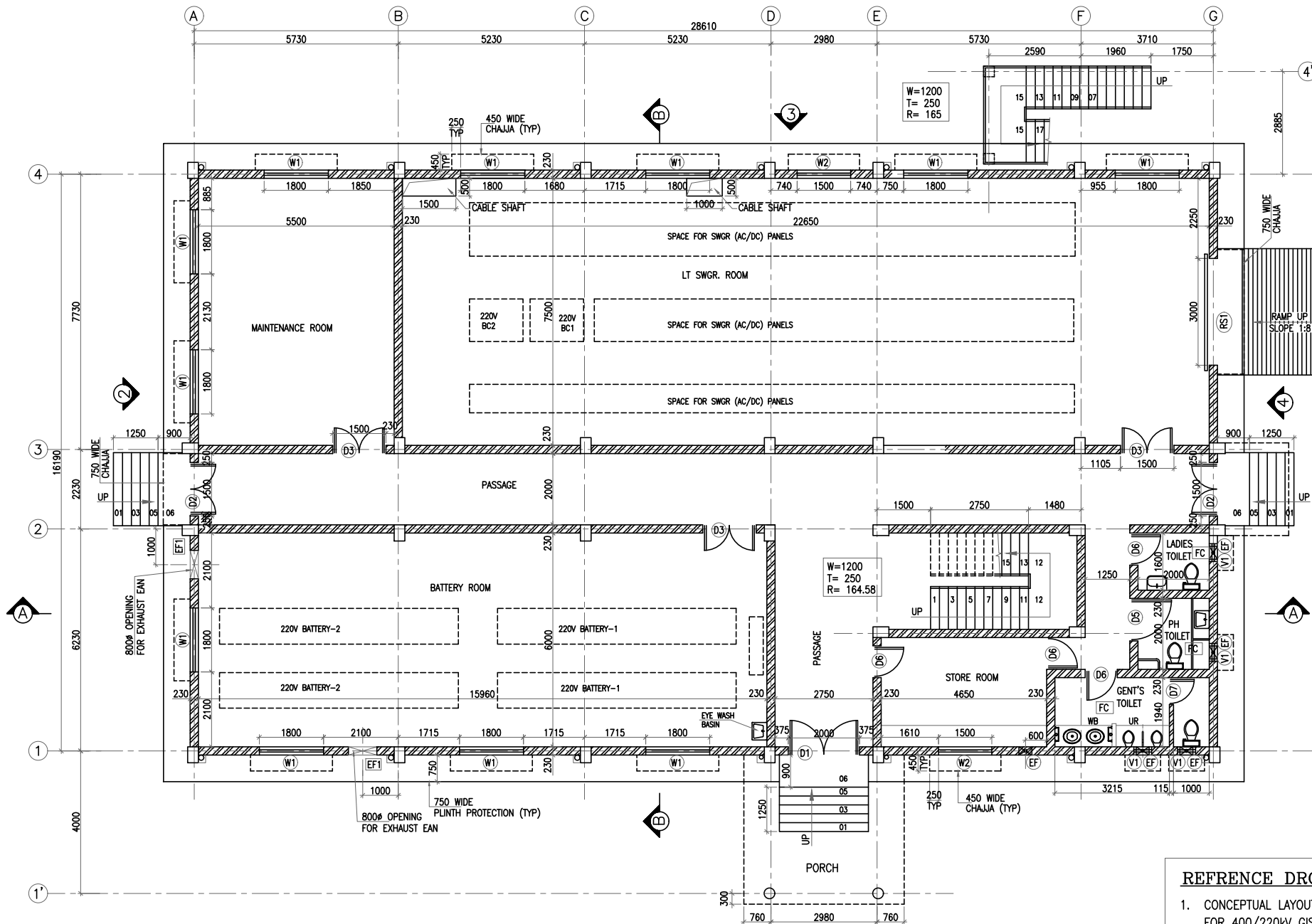

GROUND FLOOR PLAN

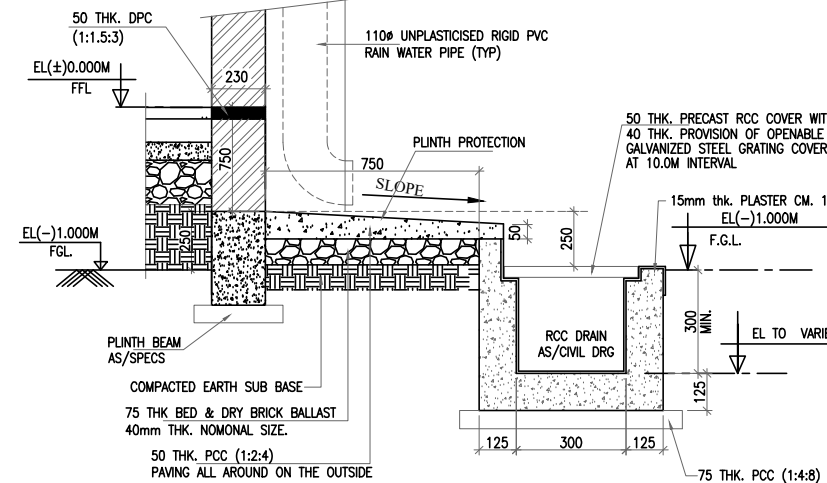

PLINTH PROTECTION ALONG BUILDING WITH DRAIN-TYPICAL

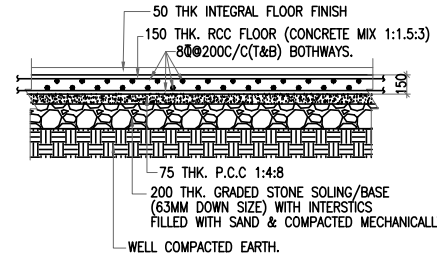

DETAIL OF GRADE SLAB

LEGEND:-

	SIDE HUNG OPENABLE PANEL
	FIXED GLASS PANEL
FFL	= FINISH FLOOR LEVEL
FGL	= FINISH GRADE LEVEL
H.P.	= HIGH POINT
L.P.	= LOWER POINT
E.F.	= EXHAUST FAN
E.L.	= ELEVATION LEVEL
T.O.C	= TOP OF CONCRETE
N.T.S	= NOT TO SCALE
TYP.	= TYPICAL
AC	= AIR CONDITIONED
FC	= FALSE CEILING
FF	= FALSE FLOOR

NOTES:-

- ALL DIMENSIONS ARE IN MILLIMETERS AND LEVELS ARE IN METERS UNLESS OTHERWISE SPECIFIED.
- ALL DOOR-WINDOW, ETC. HEIGHT SHALL BE CONSIDERED FROM FINISH FLOOR LEVEL.

REFERENCE DRGS.

- CONCEPTUAL LAYOUT OF CONTROL ROOM BUILDING FOR 400/220KV GIS SUB STATION AT ERSAMA DRG. NO.: TB-3-420-316-002

REV.	DATE	ALTERED	REV.	DATE	ALTERED	REV.	DATE	ALTERED	REV.	DATE	ALTERED
		CHD/APPD			CHD/APPD			CHD/APPD			CHD/APPD
ZONE			ZONE			ZONE			ZONE		REVISD AS PER REVISED MECHANICAL DRAWING

PROJECT:	400/220kV GIS SUBSTATION AT ERSAMA, ODISHA & 400kV AIS FEEDER BAY EXTENSION AT DUBURI, ODISHA		
OWNER:	ODISHA POWER TRANSMISSION CORPORATION LIMITED		
BHARAT HEAVY ELECTRICALS LTD. TRANSMISSION BUSINESS GROUP NOIDA	NAME	SIGN.	DATE
	DRN. RDA CIVIL	--sd--	01.05.2023
	CHD. SV/AK	--sd--	02.05.2023
APPD. PLK	--sd--	02.05.2023	NO. OF VAR.
DEPT. TBG CODE	UNTOL. DIMS. GR. 9/M/Y	SCALE N.T.S	WEIGHT (KG) N.A.
TITLE	REF. TO ASSY. DRG. N.A.	ITEM NO. N.A.	NO. OF ITEMS N.A.
CONTROL ROOM BUILDING-GROUND FLOOR PLAN	DRG. NO. TB-1-420-607-700	REV. 01	
	SHT. No 01	NO. OF SHT. 04	

THE INFORMATION ON THIS DOCUMENT IS THE PROPERTY OF BHARAT HEAVY ELECTRICALS LIMITED. IT MUST NOT BE USED DIRECTLY OR INDIRECTLY IN ANY WAY DETRIMENTAL TO THE INTEREST OF THE COMPANY

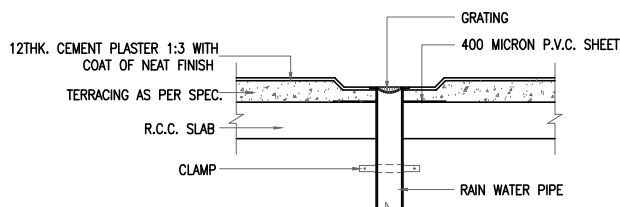

TYPICAL DETAIL OF KHURRA WITH RAIN WATER PIPE

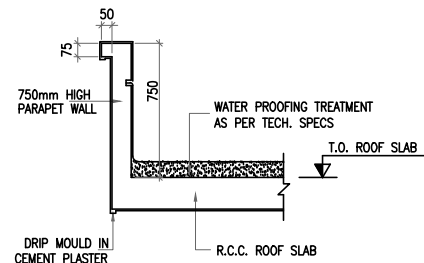

TYP. DETAIL OF PARAPET

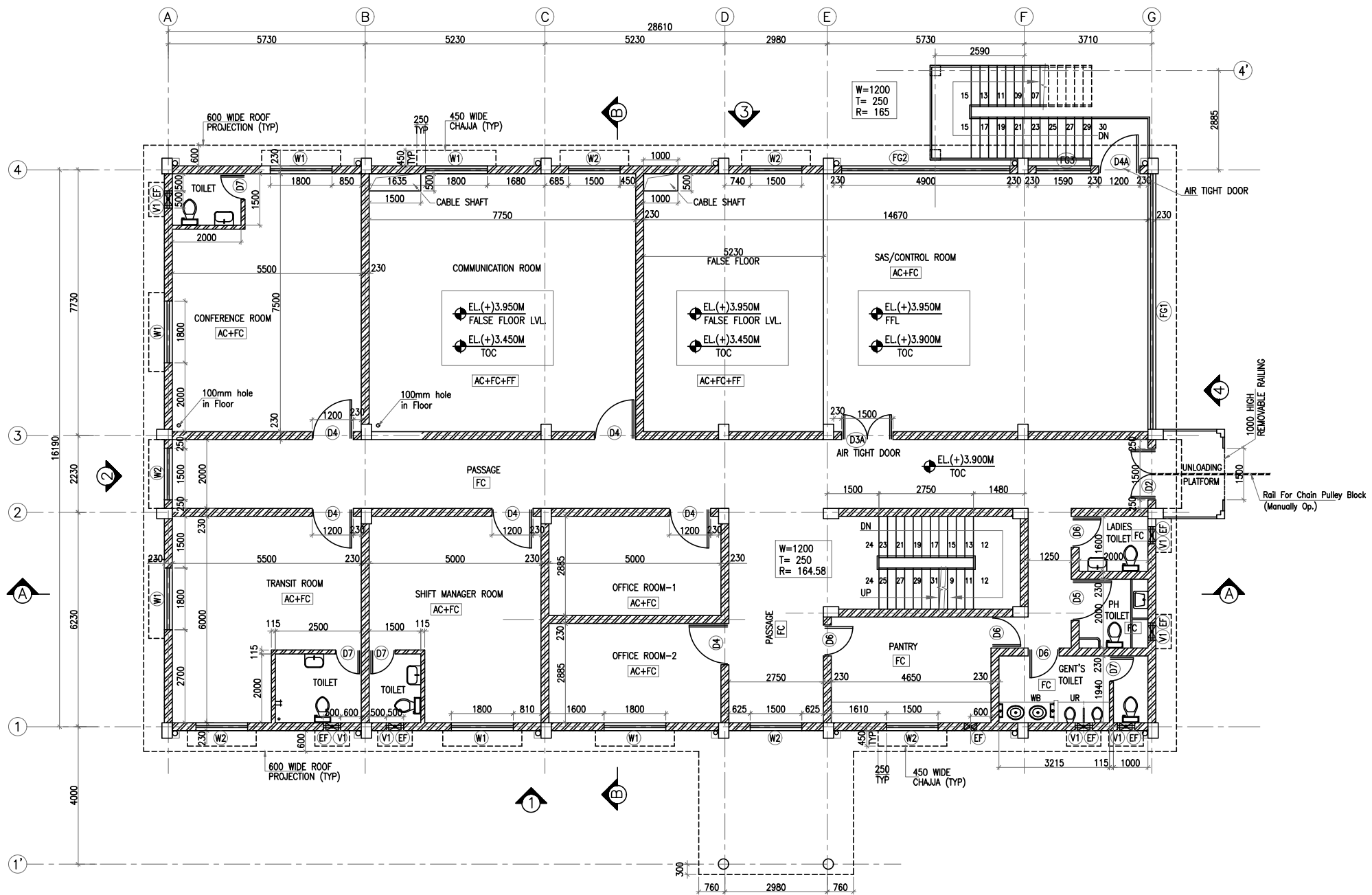

FIRST FLOOR PLAN

SCHEDULE OF FINISHES
(AS PER TECHNICAL SPECIFICATION)

- 1.0 BRICK WORK:
 - 1.1 230mm THK. BRICK MASONRY IN C.M. (1:5) USING FLY ASH BRICK AS PER OPTCL TS.
- 2.0 PLASTER:
 - 2.1 INTERNAL:
 - 12mm THK. PLASTER (1:6 CEMENT : SAND) MORTAR ON SMOOTH SIDE OF WALL.
 - 15mm THK. PLASTER (1:6 CEMENT : SAND) MORTAR ON ROUGH SIDE OF SINGLE OR HALF BRICK WALL.
 - 2.2 EXTERNAL:
 - 18mm THK. PLASTER IN TWO LAYER.
 - UNDER LAYER 12mm THK. (1:5 CEMENT : SAND) MORTAR AND TOP LAYER 6mm THK. (1:3 CEMENT : SAND) MORTAR
 - 2.3 CEILING EXCEPT FOR WHERE FALSE CEILING WILL BE PROVIDED. 6mm THK. PLASTER (1:3 CEMENT : SAND)
- 3.0 FLOORING:
 - 3.1 OFFICE, PASSAGE, TRANSIT ROOM, CONFERENCE RM, SAS ROOM:- GLAZED VITRIFIED TILE FLOORING AS PER OPTCL TS.
 - 3.2 BATTERY ROOM:- ACID AND ALKALI RESISTANT TILES FLOORING. ACID AND ALKALI RESISTANT TILES UPTO 2100 HEIGHT AND ACID PROOF PAINT FOR BALANCE HEIGHT.
 - 3.3 LT SWITCH GEAR ROOM, MAINTENANCE ROOM, STORE ROOM:- CEMENT CONCRETE WITH METALLIC HARDENER TOPPING.
 - 3.4 SHIFT MANAGER ROOM, CHARGER ROOM, STORE ROOM:- VITRIFIED TILE FLOORING.
 - 3.5 TOILET, PANTRY:- CERAMIC TILES FLOORING AND DADO UPTO FALSE CEILING CERAMIC TILES.
 - 3.6 SKIRTING:- 150 HIGH SKIRTING MATCHING WITH THE FLOOR SHALL BE PROVIDED.
- 5.0 PAINTING.
 - 5.1 INSIDE FACES OF BRICK WALL WILL HAVE PLASTIC EMULSION/ACRYLIC EMULSION PAINT IN ALL AC AREA, DISTEMPER IN ALL OTHER AREA AND IN TOILET WILL HAVE ABOVE DADO WHITE WASH.
 - 5.2 OUTSIDE FACES OF WALL BE ACRYLIC SMOOTH EXTERIOR PAINT OVER PLASTER SURFACE.
 - 5.3 CEILING TO HAVE PLASTIC EMULSION PAINT, IN BATTERY ROOM HAVE ACID PROOF PAINT. FALSE CEILING IN PASSAGE AT FIRST FLOOR, CHARGER ROOM, TRANSIT ROOM, SAS ROOM, OFFICE ROOM, CONFERENCE ROOM, CHARGER ROOM, TOILET & PANTRY.

WATER PROOFING ON ROOF:

- CEMENT BASED WATER PROOFING TREATMENT OF ROOFS BALCONIES, TERRACES ETC SHALL BE PROVIDED WITH AVERAGE THICKNESS OF 120MM AND MINIMUM THICKNESS AT KHURRA AS 65 MM AND LAID CONSISTING OF FOLLOWING OPERATIONS:
- (A) A SLURRY COAT OF NEAT CEMENT USING 2.75 KG/SQM OF CEMENT ADMIXED WITH PROPRIETARY WATER PROOFING COMPOUNDS CONFORMING TO IS: 2645 SHALL BE APPLIED AND GROUTED OVER THE RCC SLAB INCLUDING CLEANING THE SURFACE BEFORE TREATMENT.
 - (B) PLAIN CEMENT CONCRETE 1:5:10 (1: CEMENT: 5 FINE SAND: 10 BURNT BRICK AGGREGATE OF 40 MM NOMINAL SIZE) ADMIXED WITH PROPRIETARY WATER PROOFING COMPOUND CONFORMING TO IS 2645 OVER 20 MM THICK LAYER OF CEMENT MORTAR OF MIN :5 (CEMENT 5 COARSE SAND) ADMIXED WITH PROPRIETARY WATER PROOFING COMPOUND CONFORMING TO IS : 2645 AND FINALLY THE SURFACE SHALL BE FINISHED WITH TROWEL WITH NEAT CEMENT SLURRY AND MAKING OF 300 X 300 MM SQUARE
 - (C) AFTER TWO DAY OF PROPER CURING A SECOND COAT OF CEMENT SLURRY ADMIXED WITH PROPRIETARY WATER PROOFING COMPOUND CONFORMING TO IS 2645 SHALL BE APPLIED.
 - (D) THE SURFACE SHALL BE FINISHED WITH 20 MM THICK JOINT LESS CEMENT MORTAR OF MIX 1:4 (1 CEMENT :4 COURSE SAND) ADMIXED WITH PROPRIETARY WATER PROOFING COMPOUND CONFORMING TO IS : 2645 AND FINALLY THE SURFACE SHALL BE FINISHED WITH TROWEL WITH NEAT CEMENT SLURRY AND MAKING OF 300 X 300 MM SQUARE
 - (E) THE WHOLE TERRACE SO FINISHED SHALL BE FLOODED WITH WATER FOR A MINIMUM PERIOD OF TWO WEEKS FOR CURING AND FOR FINAL TEST. ALL ABOVE OPERATIONS SHALL BE DONE IN ORDER AN AS DIRECTED AND SPECIFIED BY THE ENGINEER-IN CHARGE.

NOTES:-

- 1 ALL DIMENSIONS ARE IN MILLIMETERS AND LEVELS ARE IN METERS UNLESS OTHERWISE SPECIFIED.
- 2 ALL DOOR-WINDOW, ETC. HEIGHT SHALL BE CONSIDERED FROM FINISH FLOOR LEVEL.

PROJECT:	400/220kVGS SUBSTION AT ERSAMA, ODISHA & 400kV AIS FEEDER BAY EXTENSION AT DUBURI, ODISHA
OWNER:	ODISHA POWER TRANSMISSION CORPORATION LIMITED

	BHARAT HEAVY ELECTRICALS LTD. TRANSMISSION BUSINESS GROUP NOIDA	NAME	SIGN.	DATE	NO.OF VAR.
		DRN. RDA CIVIL	--sd--	01.05.2023	N.A.
		CHD. SV/AK	--sd--	02.05.2023	N.A.
APPD. PLK	--sd--	02.05.2023	N.A.		

DEPT. TBG CODE	UNTOL. DIMS. GR. 9/M/Y	SCALE N.T.S	WEIGHT (KG) N.A.	REF. TO ASSY. DRG. N.A.	ITEM NO. N.A.	NO.OF ITEMS N.A.
----------------	------------------------	-------------	------------------	-------------------------	---------------	------------------

TITLE	CONTROL ROOM BUILDING-FIRST FLOOR PLAN	DRG.NO. TB-1-420-607-701	REV. 01
CARD CODE	NA	SHT. No 02	NO. OF SHT. 04

REV.	DATE	ALTERED	REV.	DATE	ALTERED	REV.	DATE	ALTERED	REV.	DATE	ALTERED
		CHD/APPD			CHD/APPD			CHD/APPD			CHD/APPD
ZONE			ZONE			ZONE			ZONE	01	05-06-23
											REVISD AS PER REVISED MECHANICAL DRAWING

THE INFORMATION ON THIS DOCUMENT IS THE PROPERTY OF BHARAT HEAVY ELECTRICALS LIMITED. IT MUST NOT BE USED DIRECTLY OR INDIRECTLY IN ANY WAY DETRIMENTAL TO THE INTEREST OF THE COMPANY

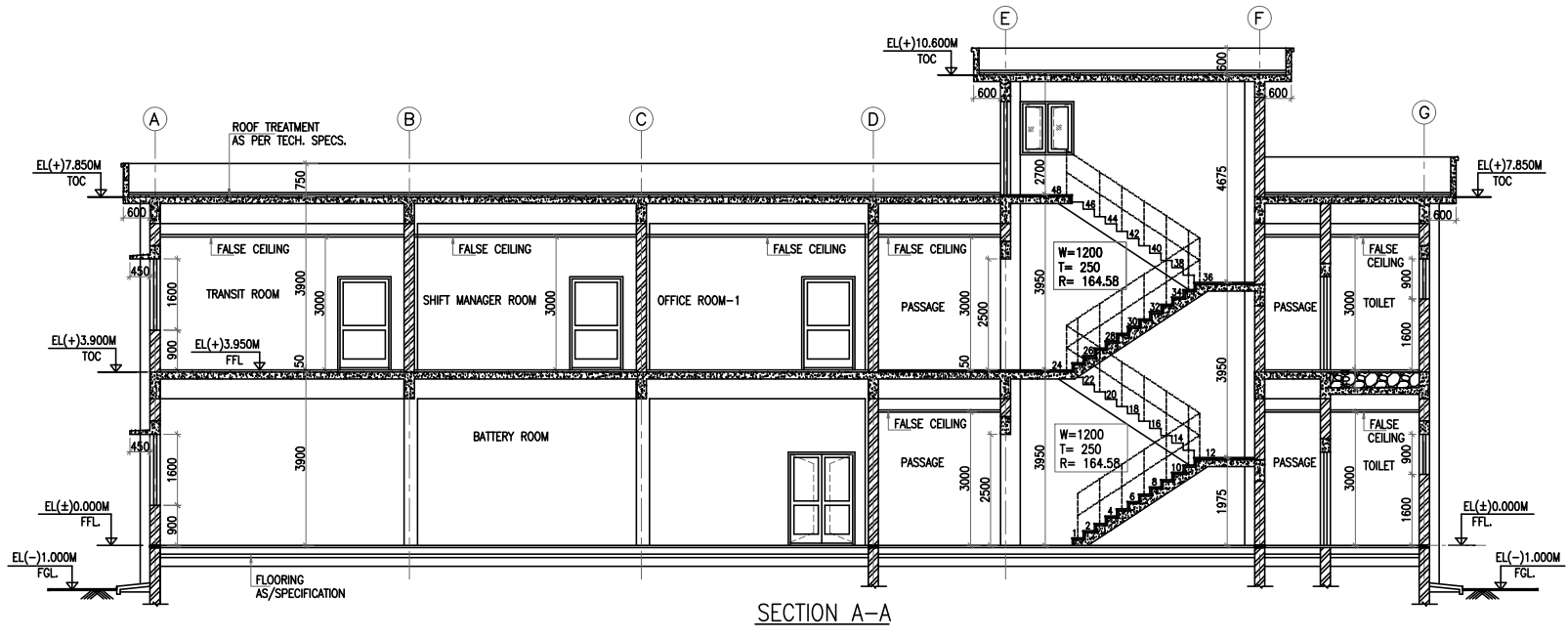

SECTION A-A

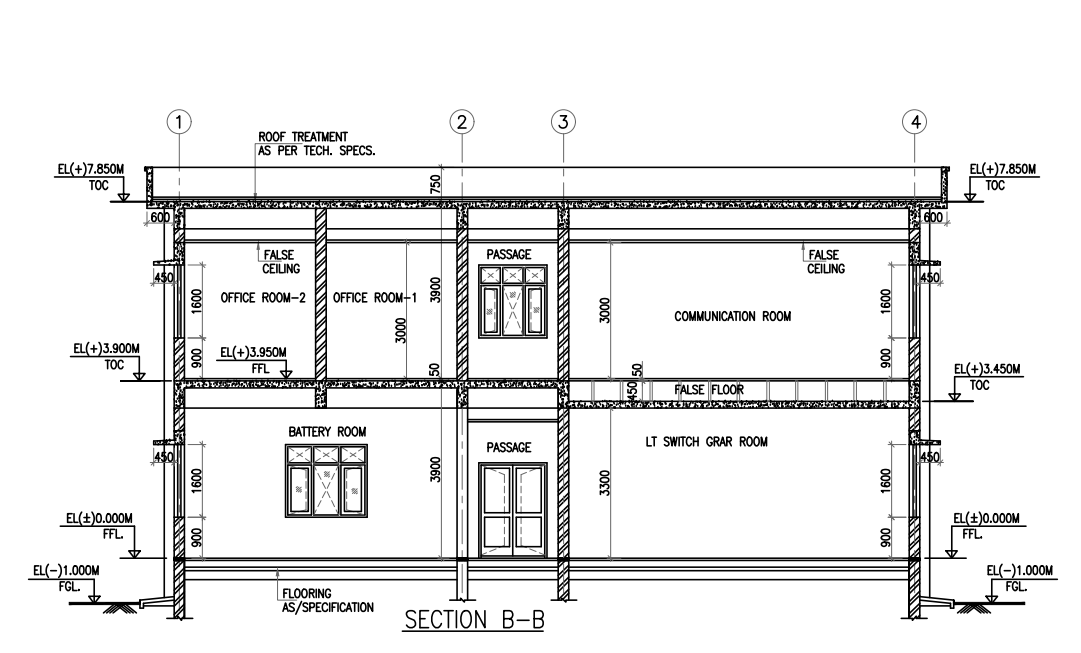

SECTION B-B

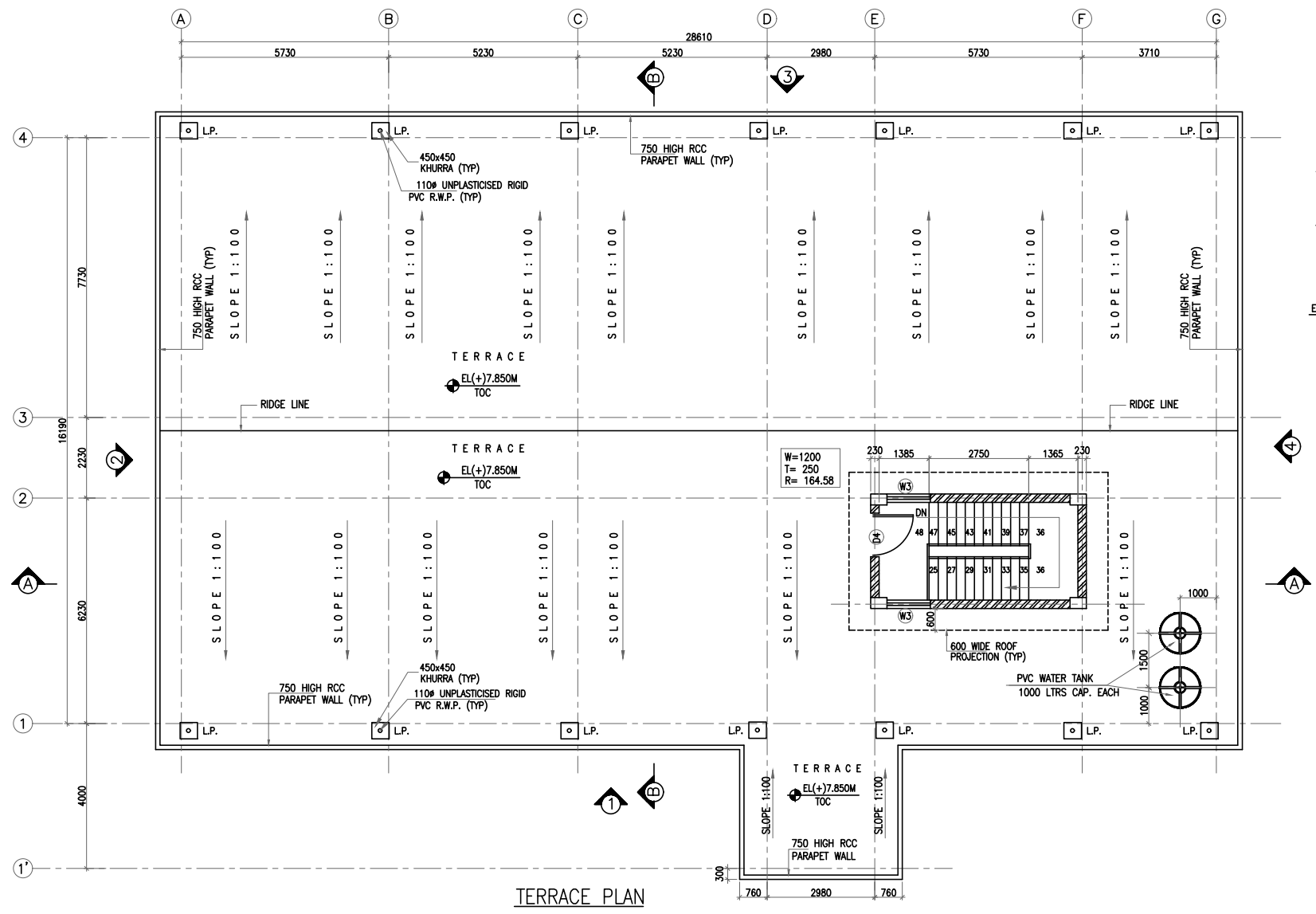

TERRACE PLAN

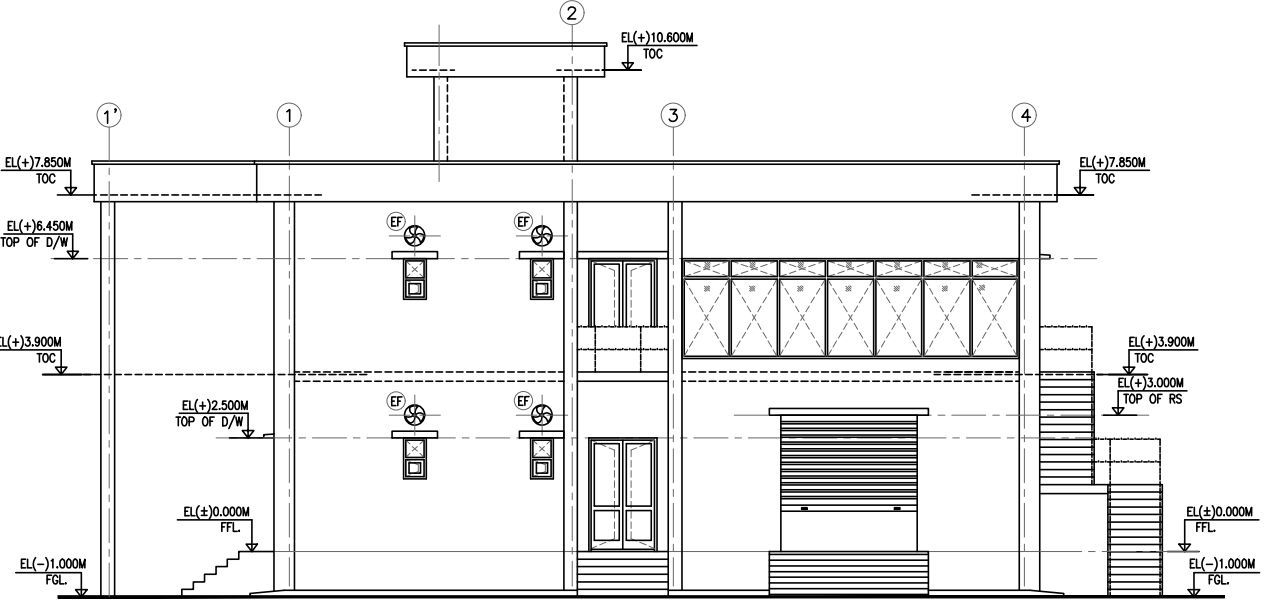

ELEVATION-4

- NOTES:-
- 1 ALL DIMENSIONS ARE IN MILLIMETERS AND LEVELS ARE IN METERS UNLESS OTHERWISE SPECIFIED.
 - 2 ALL DOOR-WINDOW, ETC. HEIGHT SHALL BE CONSIDERED FROM FINISH FLOOR LEVEL.

PROJECT: 400/220kV GIS SUBSTATION AT ERSAMA, ODISHA & 400kV AIS FEEDER BAY EXTENSION AT DUBURI, ODISHA

OWNER: ODISHA POWER TRANSMISSION CORPORATION LIMITED

	BHARAT HEAVY ELECTRICALS LTD.	NAME	DRN.	RDA CIVIL	SIGN.	--sd--	DATE	01.05.2023	NO. OF VAR.
	TRANSMISSION BUSINESS GROUP	CHD.	SV/AK			--sd--	02.05.2023	N.A.	
	NOIDA	APPD.	PLK			--sd--	02.05.2023	N.A.	

DEPT. TBG CODE	UNTOL. DIMS. GR. 9/M/Y	SCALE	WEIGHT (KG)	REF. TO ASSY. DRG.	ITEM NO.	NO. OF ITEMS
		N.T.S	N.A.	N.A.	N.A.	N.A.

TITLE	DRG. NO.	REV.
CONTROL ROOM BUILDING-TERRACE PLAN & SECTIONS	TB-1-420-607-702	01
	SHT. No 03	NO. OF SHT. 04

REV.	DATE	ALTERED	REV.	DATE	ALTERED	REV.	DATE	ALTERED	REV.	DATE	ALTERED
		CHD/APPD			CHD/APPD		01	05-06-23			RDA SV/AK
ZONE			ZONE			ZONE		REVISED AS PER	ZONE		REVISED MECHANICAL DRAWING

THE INFORMATION ON THIS DOCUMENT IS THE PROPERTY OF BHARAT HEAVY ELECTRICALS LIMITED. IT MUST NOT BE USED DIRECTLY OR INDIRECTLY IN ANY WAY DETRIMENTAL TO THE INTEREST OF THE COMPANY

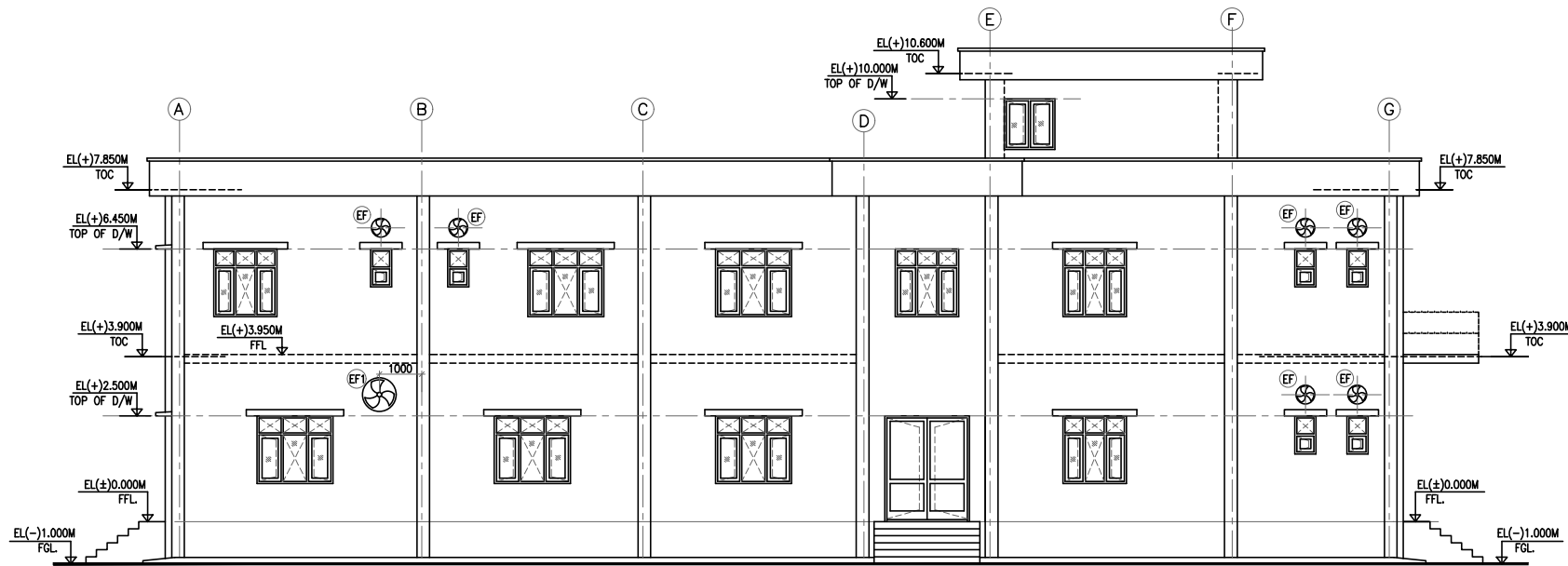

ELEVATION-1

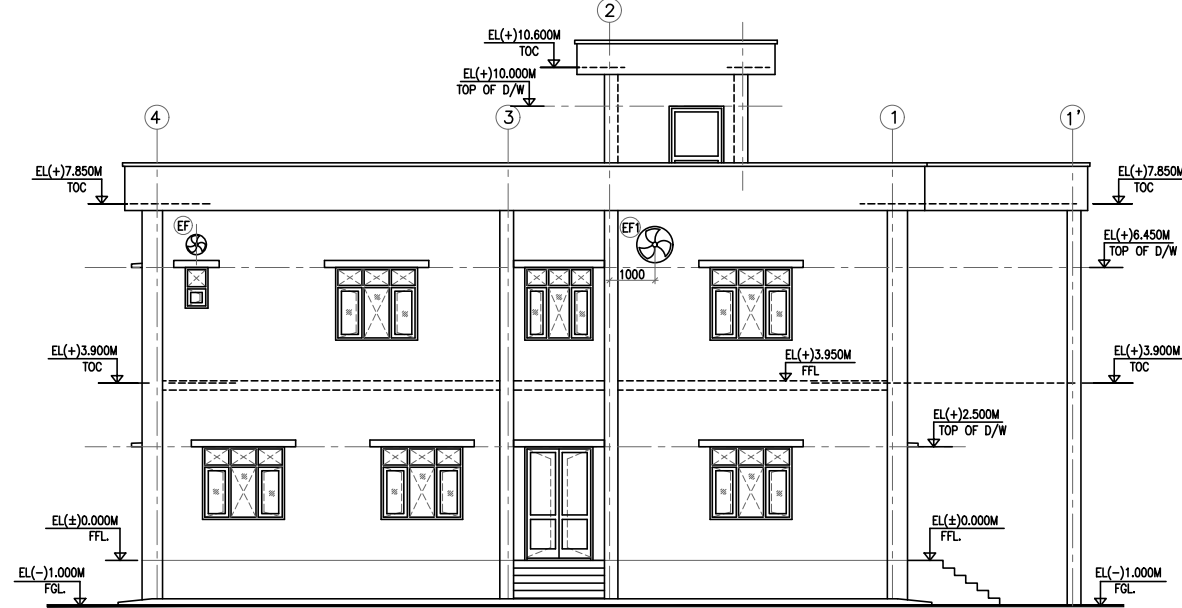

ELEVATION-2

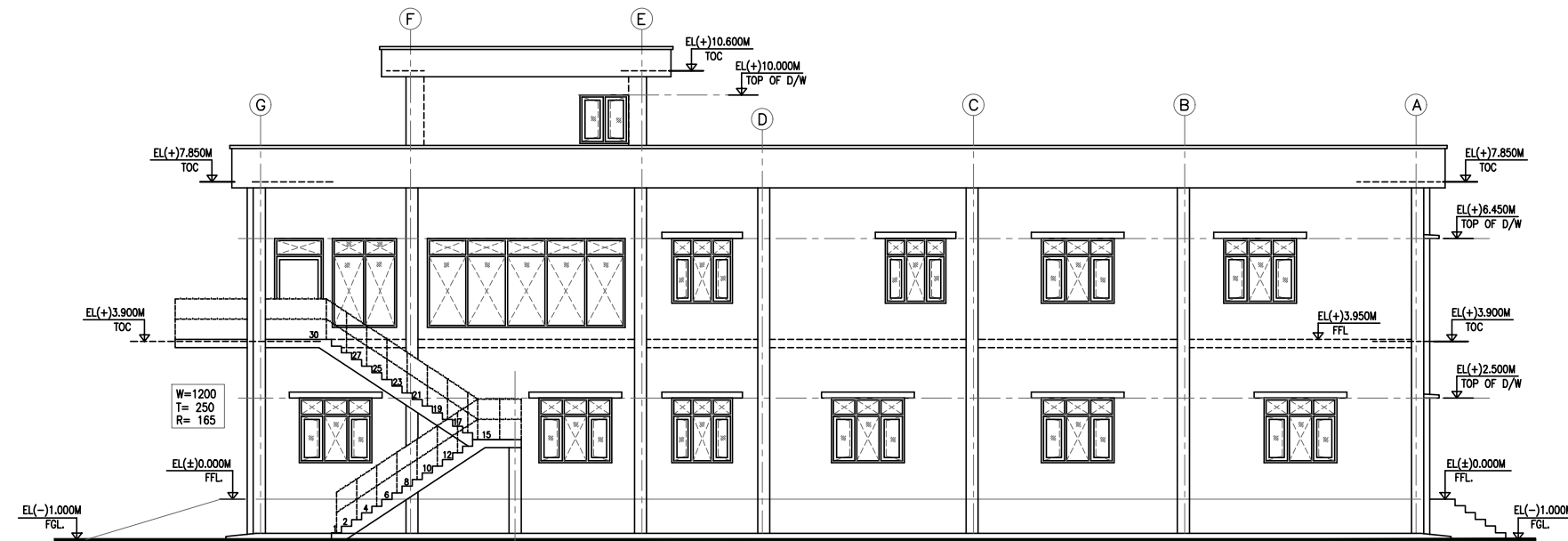

ELEVATION-3

NOTES:-

- 1 ALL DIMENSIONS ARE IN MILLIMETERS AND LEVELS ARE IN METERS UNLESS OTHERWISE SPECIFIED.
- 2 ALL DOOR-WINDOW, ETC. HEIGHT SHALL BE CONSIDERED FROM FINISH FLOOR LEVEL.

PROJECT: 400/220kV GIS SUBSTATION AT ERSAMA, ODISHA & 400kV AIS FEEDER BAY EXTENSION AT DUBURI, ODISHA

OWNER:  ODISHA POWER TRANSMISSION CORPORATION LIMITED

DRN.	NAME	SIGN.	DATE	NO. OF VAR.
CHD.	RDA CIVIL	--sd--	01.05.2023	N.A.
APPD.	SV/AK	--sd--	02.05.2023	N.A.
	PLK	--sd--	02.05.2023	N.A.

DEPT. TBG CODE	UNTOL. DIMS. GR. 9/M/Y	SCALE	WEIGHT (KG)	REF. TO ASSY. DRG.	ITEM NO.	NO. OF ITEMS
		N.T.S	N.A.	N.A.	N.A.	N.A.

TITLE: CONTROL ROOM BUILDING-ELEVATIONS

DRG. NO. TB-1-420-607-703

REV. 01

SHT. No 04 NO. OF SHT. 04

REV.	DATE	ALTERED	REV.	DATE	ALTERED	REV.	DATE	ALTERED	REV.	DATE	ALTERED
		CHD/APPD			CHD/APPD			CHD/APPD	01	05-06-23	CHD/APPD SV/AK
ZONE			ZONE			ZONE			ZONE	REVISED AS PER REVISED MECHANICAL DRAWING	

THE INFORMATION ON THIS DOCUMENT IS THE PROPERTY OF BHARAT HEAVY ELECTRICALS LIMITED. IT MUST NOT BE USED DIRECTLY OR INDIRECTLY IN ANY WAY DETRIMENTAL TO THE INTEREST OF THE COMPANY

Bharat Heavy Electricals Limited

Project: 400/220 kV GIS SUB STATION AT ERSAMA, PARADEEP, ODISHA

Technical Specification: 220V Lead Acid Plante type Battery Bank along with accessories

Doc No. TB-420-316-025A **Rev** 00

Contents

SECTION 2:

EQUIPMENT SPECIFICATION UNDER SCOPE OF SUPPLIES/
SERVICE

1. CUSTOMER TECHNICAL SPECIFICATION

PART – A
**TECHNICAL SPECIFICATION FOR 220 VOLTS LEAD ACID PLANTE STORAGE
 BATTERY**

A.1. SCOPE :

A.1.1 These specifications cover the design, manufacturer assembly shop testing at manufacturer's works before despatch, supply and delivery at SITE and erection testing and commissioning of 220 volt lead Acid Plante Storage battery

A.1.2. The scope of supply shall include all parts and accessories etc which are usual and necessary for erection operation and maintenance of the battery banks and the chargers. as specified, above though not individually and specifically stated or enumerated.

A.2.0. STANDARDS :

2.1 The equipments shall comply in all respects with the latest edition of relevant Indian Standard Specifications except for the modifications specified herein. The equipments manufactured according to any other authoritative national / international standard which ensure an equal or better quality than the provisions of these specifications shall also be acceptable. Where the equipment offered conform to any other standard, salient points of differences between the proposed standard and the provisions of these specifications shall be clearly brought out in the tender. A Xerox copy of such standards [in English shall be enclosed with the offer]

2.2. A LIST OF RELEVANT STANDARDS IS GIVEN BELOW :

- | | | |
|--------|---------------------|---|
| [i] | IS-1652-1991 - | Specification for stationery cells and batteries, lead Acid type with Plante Positive Plates |
| [ii] | IS 266-1993 - | Specification for Suphuric Acid. |
| [iii] | IS-6071-1986 - | Specification for synthetic separators for lead acid batteries. |
| [iv] | IS:1069-1993 - | Specification for quality tolerances water for storage batteries. |
| [v] | IS:1146-1981 | Specification for rubber and plastic containers for lead acid storage batteries |
| [vi] | IS:8320-2000 - | General requirements and methods of tests for lead-acid storage batteries |
| [vii] | IS:1885-Part-8/1996 | Electro technical vocabulary-stationary cells & batteries. |
| [viii] | IEEE-485/1983 - | IEEE recommended practice for sizing large lead storage batteries for generating stations and sub-stations. |

A3.0 INSTALLATIONS :

A3.1 Equipments covered under these specifications shall be suitable for indoor installation

A4.0 PARTICULARS OF THE SYSTEM:



A4.1 **Two sets** of 220 Volts ~~350AH~~ and 645 AH capacity battery alongwith equipments such as boost charger, trickle charger shall be sufficient to cater to the DC power requirements in the Sub-stations as proposed. The system offered should be suitable to OPTCL system

A.5.0 GENERAL REQUIREMENTS OF THE EQUIPMENTS :

General requirement of the different components of the Battery system are given below

A5.1 **Two sets** of 220V, ~~350~~ & 645 AH lead acid type plante storage battery set is required for meeting the D.C. load requirements of indicating lamps, emergency lighting, relays, alarms, circuits breakers etc. The battery shall be kept in healthy conditions with the help of the existing float charging unit. The existing boost charger unit shall supply quick charging current to bring back the battery to fully charged conditions after it has discharged to a considerable extent while meeting the emergency load. The battery shall meet practically all the heavy current demands, as required for operation [closing and / or operating of circuit breakers, emergency lighting load and field flashing load etc]. It should be noted that, the 220V batteries are to be accommodated in the Battery Room and should operate satisfactorily over the entire range of ambient temperature of 0^o C to 50^o C and relative humidity of 95%

A.6.0. DETAILS OF SPECIFICATIONS OF PLANTE BATTERIES Type Battery:

6.1 The batteries shall be made of closed type lead acid cells with 'plante' type plates manufactured to conform to IS. 1652-1991

6.2. CAPACITY :

6.3. The capacity of the batteries shall be as follows

- [i] Voltage. - 220V/~~48V~~
- [ii] Output at 27^o C - 645 AH at 10 hrs discharge rate.

The batteries shall normally remain under 'floating' condition with the 'trickle' charger supplying the continuous load. However, the batteries shall be capable of supplying the following loads under emergency conditions without any assistance from the chargers and without their terminal voltage falling below 200 V [90% of rated voltage]

~~350AH/645AH~~

- [I] I stage [continuous]- 35A for 10 hours, 65 A for 10 hours
- [ii] Stage emergency - 15A for 3 hours for lighting

6.4 The number of cells for the 220 V/48V batteries shall be so chosen that for the nominal floating voltage of the cells, the battery voltage shall be 237.5V/~~51.85V~~ and for the minimum [discharged condition] voltage of the cells, the voltage of the battery shall not be less than 198V/~~43.2V~~, while the assigned rating of the battery bank can not lowered below its rated voltage of 220/~~48V~~ volts.

A7.0 DESIGN AND CONSTRUCTION DETAILS : (For Plante Type)



7.1 **Containers** The containers for the cells shall be of impervious, moulded transparent, plastic/glass material having heat-resisting high strength, non-reacting and low inflammable properties conforming to IS-1146-1981. The containers shall be mounted on insulators blocks. The containers shall be of robust construction and free from flaws, bubbles or foreign matter. The surface of the containers shall have a finish substantially free from blisters, rough spots, scales, blow holes and other imperfections or deformations. The handle bars, if provided shall be of such that sufficient sediment space shall be available and the batteries will not have to be cleared out during their normal life. Battery containers shall be subjected to type, Routine and Acceptance Tests as per the requirements of IS-1146-1981. The containers of the label attached firmly to the containers shall be marked with the information as per requirements of cl No. 2.2 of the above standard. The supplier's manufacturer's test certificates shall be submitted by the tenderer for the scrutiny of the purchaser.

7.2 **Plates** The positive plates shall be of pure lead lamelle type with plate formation. The negative plates shall be pasted antimonial-lead Grid type so designed as to hold the active material securely in place and in firm contact with the grid during service. The plates shall be designed for maximum durability and shall not buckle during all service conditions including high rate of discharge and the fluctuation of load.

7.3 **Separators** The separators shall be of synthetic material conforming to the latest edition of IS-6071-1986. These shall permit free flow of electrolyte and would not be affected by the chemical reaction inside the cell and shall last for indefinite time. The internal resistance factor of the separators shall assure high discharge characteristics under all operating conditions. Proper arrangement to keep end plates in position shall be furnished by the bidder alongwith his offer.

7.4 **Electrolyte** The electrolyte shall be prepared from the battery grade sulphuric acid conforming to IS-266-1993 and shall have a specific gravity of 1.2 at 27°C. The sulphuric acid of battery grade shall be colourless liquid. The concentrated sulphuric acid on dilution with an equal volume of distilled water shall be free from suspended matter and other visible impurities. The sulphuric acid shall meet the requirements of columns – 4 and 5 Table –1 of IS-266-1993. The requisite quantity shall be despatched in non-returnable containers suitably packed and marked as per the requirements of the above Indian Standards. The container materials and packing shall be subject to approval of the purchaser.

Sufficient quantity of distilled water conforming to IS-1069-1993 shall be supplied in non-returnable containers to correct the level of electrolyte during initial testing and commissioning. The material of containers and packing shall be subject to the approval of the purchaser.

7.5 **Plate group bar with terminals** The plate group bar with terminals shall conform to IS-1652-1991. The positive and negative terminals shall be clearly marked for easy identification. The legs of the plates of like polarity shall be connected to the load turned to a horizontal group



bar having an upstanding terminal post adopted for connection to the external circuit. The group bars shall be sufficiently strong to hold the plates in position.

7.6. **Buffers/spring** Suitable buffers / springs shall be provided in the cells to keep the end plates in position. These shall have adequate length and strength.

7.7. **Cell lids** Lids used with sealed or closed type cells shall be of glass, plastic or ebonite and shall be provided with vent plugs. Terminal post shall be suitably sealed at the lid to prevent escape of acid spray by means of rubber grommets, sealing compound or other suitable device. The positive and negative terminal posts shall be clearly and indelibly marked for easy identification.

7.8. **Water** - Water used for preparation of electrolyte and also to bring the level of electrolyte to approximately correct height during operation / testing shall conform to relevant standards.

7.9. **Venting device** The venting device shall be anti splash type and shall allow gases to escape freely but shall effectively prevent acid particles or spray from coming out. There shall be two vent holes, one serving as a guide for acid level indicator for checking the electrolyte level and other to permit drawing of electrolyte samples, servicing, checking of specific gravity etc.

7.10. **Marking** Acid level line shall be permanently and indelibly marked around on all the containers.

The following information shall be indelibly marked on the outside surface of each cell:

- [i] Manufacturer's name, type and trade mark.
- [ii] Nominal voltage
- [iii] AH capacity at 10 hours rate with specified end cell voltage.
- [iv] Cell number
- [v] Upper and lower electrolyte level in case of transparent containers
- [vi] Type of positive plate
- [vii] Type of container
- [viii] Date of manufacture [month and year] or [week and year].

A8.0. INSTALLATION OF BATTERY :

8.1 The battery set shall be installed on wooden racks in a separate battery room non air – conditioned but ventilated. The tenderer shall offer racks and mounting insulators etc.

8.2 The cell shall be arranged on the racks in a two-tier arrangement with two rows of cells on each tier or with some other suitable arrangement depending upon the availability of space inside the battery room. The lay out shall be subject to the approval of the purchaser. The racks shall be constructed of best quality seasoned **teak wood** / with metallic stand with at least three [3] coats of anti-acid paint of approved shade and also flame proof coating. These racks shall be such that cells are located at convenient height to facilitate maintenance and they may be so constructed so as to promote free access to the floor directly beneath the rack to facilitate easy cleaning of the floor. These shall be designed and arranged in such a way that easy handling of the cells is possible while in operation. Numbering tags for each cell shall be attached on to the racks.

8.3. The tenderer shall indicate and include the proposed arrangement of the batteries and include arrangement for fixing and mounting of inter-bank inter-row, inter-cell and tap-off connectors etc.

A9.0. CONNECTORS:

Bars tinned copper lead connectors shall be employed for Inter-cell and inter-row, inter-tier connections. However, the tee-off connection from the battery unit shall be made with acid resisting cables of suitable size. A suitable terminal box alongwith acid-resisting cable shall be provided by the tenderer for this purpose. The connectors shall preferably be of bolted type and the bolts and nuts shall be of similar material as that of connectors and shall be provided with corrosion resisting lead coating

The connectors shall be of sufficient cross-section to withstand all the working conditions including one minute discharge rate as well as short circuit conditions.

A.10. ACCESSORIES :-

The equipments and accessories, listed below shall be furnished as part of each battery set and the price of the battery quoted shall be inclusive of these items.

- [a] Teak wood racks with three coats of anti-acid paint and flame-proof coating.
- [b] Stand insulators +5% extra.
- [c] Cell insulators +5% extra.
- [d] All Cell interconnectors and end take-offs.
- [e] Lead coated connection hardware such as bolts nuts etc.5% extra. Or any other connector suitable for Battery
- [f] Cell numbering tags with fixing arrangement.
- [g] Teakwood, cable clamps with hardware.
- [h] Diluted sulphuric acid of sufficient quantity and of specific gravity according to the relevant ISS and 10% extra shall be supplied in non-returnable acid proof containers, suitable packed
- [i] Two numbers cell testing centre-zero voltmeters 3-0-3 volts range, Accuracy class shall be 0.5 or better and resistance not less than 1000 ohms
- [j] One number syringe type hydrometer complete with accessories and suitable for measuring SP gravity between 1.1 to 1.320 with graduation of 0.005 Sp. Gravity together with temperature correction charts.
- [k] One number floating hydrometer
- [l] Two numbers thermo-meters having range 0-100 deg. C whose one division of the graduated scale shall represent at the most 1 degree centigrade with separate gravity correction chart.
[Accuracy of calibration shall not be less than 0.5°C]
- [m] One number wall mounting teak-wood for hydrometers and thermo-meters
- [n] Two numbers acid-resisting plastic jugs [2 litre capacity]



- [o] Two numbers plastic funnels.
- [p] Two numbers rubber syphone.
- [q] Two numbers rubber aprons
- [r] Two pairs of rubber gloves
- [s] Two pairs of rubber boots-knee height.
- [t] Two sets special tools or tools required for connecting the terminals of the batteries
- [u] The battery terminals shall be brought out in a junction box to be mounted on the battery stands.
- [v] Ampere-hour meter[10 hour discharge rate] of 600 –1250 AH range-1 no
- [w] Any other accessories not specified but required for installation satisfactory operation and maintenance of batteries for a period of 5 [five] years.

A.11.0 MAXIMUM SHORT CIRCUIT CURRENT :

The Bidder shall state the maximum short circuit current of each battery alongwith the safe duration in seconds which it can withstand. Methods, proposed to be adopted for protecting batteries from the short circuit conditions should also be stated to avoid damage to the battery and loss to the associated equipment.

A.12 VENTILATION :

The bidder shall indicate in his bid the requirements of ventilation in the battery room. The battery shall operate satisfactorily over the entire range of the temperature and humidity indicted in this specification without affecting its normal life. Bidder shall indicate the percentage reduction in battery capacity at the lowest temperature of 27 deg C. .If any special ventilation requirements are necessary, the same shall be indicated

A.13. CAPACITY :

The standard Ampere-hour capacity at ten hour rate shall be **645 AH** with an end cell voltage of 1.85 volts/cell.

A.14. CHARGING :

The bidders shall state whether an equalising charge is recommended for the battery. If so, the equalising charge voltage, current, duration and the interval between the equalising charging shall be specified in the Data sheet. Bidder shall also indicate the requirements for boost charging.

A.15. LIFE :

The bidder shall quote in his offer the Guaranteed life of the battery when operating under the conditions specified.

A.16. INSTRUCTION MANUALS :

Eight sets of instruction manuals for installation, commissioning, charging and maintenance instruction shall have to be furnished

A.17. TRANSPORT :

The batteries, accessories and racks etc shall be suitably packed and transported to site.

A.18. TESTS:

A.18.1 TYPE TESTS The bidder shall submit the test reports alongwith his offer for the following type tests, conducted on the offered samples as per relevant National Standard[s] within five years from the date of opening of the bid and test witnessed by any Government Department / Government undertaking, failing which the offer is liable for rejection

- [a] Verification of constructional requirements
- [b] Verification of dimensions
- [c] Test for capacity
- [d] Test for retention of charge
- [e] Endurance Test
- [f] Ampere-hour and watt-hour efficiency test.
- [g] Test for voltage during discharge

If the type test report [s] does/do not meet the requirements as per this specification, OPTCL at its discretion may ask the supplier to conduct the above type tests [s] at the supplier's cost in the presence of OPTCL's representative without any financial liability to OPTCL

A.18.2 ACCEPTANCE TESTS Following shall constitute the acceptance tests which shall be test witnessed by the purchaser's representative at the works of the manufacturer at the cost of supplier.

- [i] Verification of marking
- [ii] Verification of dimensions
- [iii] Test for capacity for 10 hours discharge rate along with the Test for voltage during discharge
- [iv] Ampere-hour and watt-hour efficiency test.

A18.3.1 The Purchaser may at his discretion undertake test for capacity and voltage during discharge after installation of the battery at site without any extra cost.

A.18.3.2. The supplier shall arrange for all necessary equipments including the variable resistor, tools, tackles and instruments. If a battery fails to meet the guaranteed requirement, OPTCL shall have the option of asking the supplier to replace the same within 15 [fifteen] days from the date of declaring the same to be insufficient/failed / not as per the specification [s].

A.19. DRAWINGS / DOCUMENTS :

The tenderer shall submit the following drawings / documents along with his offer failing which the offer is liable for rejection.

- [a] General battery arrangement, proposed size of individual and over all dimensions along with sectional views showing all connections etc
- [b] Pamphlets and technical literature giving detailed information of

the batteries offered.

The manufacturer shall submit the following drawings / documents in 7 [seven] copies within 15[fifteen] days from the date of issue of the purchase order for purchaser's approval. -

- [a] Lay out details of the batteries.
- [b] OGA and cross-sectional details for battery cells.
- [c] Instruction manuals for initial charging and subsequent charging
- [d] Technical data, curves etc.

A.20. GUARANTEED TECHNICAL PARTICULARS :

The Guaranteed technical particulars, as called for in the Annexure-C,Section -4 shall be furnished alongwith the tender. Any tender lacking complete information in this respect is likely to be rejected.

A.21. All deviations from the specification shall be separately listed, in the absence of which it will be presumed that the provisions of these specifications are complied with by the tenderer



ANNEXURE – IV-A
(For Testing of Battery)
(To be filled in by the bidder)

CALIBRATION STATUS OF TESTING EQUIPMENTS AND INSTRUMENTS/ METERS

Name of the Test	Meters & Equipments required for the test with range, accuracy, make & Sl. No.	Date of Calibration	Due date of Calibration	Name of the Calibrating Agency	Whether Calibrating Agency is approved Govt.	Whether documents relating to Govt. approval of the calibrating Agency furnished	Whether the meters/ equipments fulfill the accuracy class as per calibration report.	Whether the calibrating agency has put any limitation towards the use of the particular meter/ equipment. if yes, state the limitations	Whether the calibrating agency has put any limitation towards the use of the particular meter/ equipment/ meter/ State the colour of the affixed sticker	In spite of imposed limitations. Whether the particular meter / equipment can still be used? Justify its use for corresponding test(s)	Remarks
1	2	3	4	5	6	7	8	9	10	11	12

Signature of the tenderer with seal & date



ANNEXURE V – A
(To be filled in by the bidder)
CHECK LIST TOWARDS TYPE TEST REPORTS FOR BATTERY

Name of the Type Test	Date of Test	Name of the Laboratory where the Test has been conducted	Whether the Laboratory is Government approved	Whether the Test report is valid as per Spn.	Whether the Test report in complete shape alongwith drawings etc. furnished or not?	Whether the type tested Plant acid battery fulfills the technical requirements as per TS	If the type tested battery does not fulfill the technical requirements as per this specification, whether the bidder agrees to conduct the particular type test again at their own cost without any financial liability to OPTCL in the presence of OPTCL's representative within the specified delivery period	Remarks
1	2	3	4	5	6	7	8	9

Signature of the tenderer with seal & date



PROJECT: 2X500 MVA, 400/220 KV GIS S/S AT ERSAMA & ASSOCIATED 2 NOS 400 KV BAY EXTN AT DUBURI	
CUSTOMER: ODISHA POWER TRANSMISSION CORPORATION LIMITED (OPTCL)	
Technical Specification	TB-4-420-316-xxx Rev 00
Section-3: Project Details and General Specification	

SECTION- 3

PROJECT DETAILS AND GENERAL SPECIFICATIONS

3.0 GENERAL

This section stipulates the General Technical Requirements under the Contract and will form an integral part of the Technical Specification.

The provisions under this section are intended to supplement general requirements for the materials, equipment and services covered under other sections of tender documents and are not exclusive. However, in case of conflict between the requirements specified in this section and requirements specified under other sections, the requirements specified under respective sections shall prevail.

3.1 PROJECT DETAILS

	Particular	Details
a)	Customer	ODISHA POWER TRANSMISSION CORPORATION LIMITED (OPTCL)
b)	Engineer/Consultant/ Inspector	-
c)	Project Title	2X500 MVA, 400/220 KV GIS S/S AT ERSAMA & ASSOCIATED 2 NOS 400 KV BAY EXTN AT DUBURI
d)	Project Location	<u>400/220kV GIS S/S</u> Place: Erasama, Paradeep District: Jagatsingha State: Odisha <u>400kV AIS S/S Bay Extn.</u> Place: Duburi District: Jajpur State: Odisha
e)	Latitude & Longitude	<u>400/220kV GIS S/S</u> North: 20°12'32" and East: 86°21'44" <u>400kV AIS S/S Bay Extn.</u> North: 20°56'14" and East: 86°00'23"
f)	Nearest Railway Station	Erasama – At a distance of about 32 km from Paradeep station Duburi – At a distance of about 14 km from Jajpur Road station
g)	Distance of project location from the Railway station	Erasama – At a distance of about 32 km from Paradeep station Duburi – At a distance of about 14 km from Jajpur Road station
h)	Nearest Major Town	Bhubaneswar
i)	Distance of the town from the project site	86 Km from Erasama & 120 Km from Duburi
j)	Nearest commercial airport	Biju Patnaik International Airport, Bhubaneswar

PROJECT: 2X500 MVA, 400/220 KV GIS S/S AT ERSAMA & ASSOCIATED 2 NOS 400 KV BAY EXTN AT DUBURI	
CUSTOMER: ODISHA POWER TRANSMISSION CORPORATION LIMITED (OPTCL)	
Technical Specification	TB-4-420-316-xxx Rev 00
Section-3: Project Details and General Specification	

k)	Distance of airport from the project site	86 Km from Erasama & 120 Km from Duburi
SITE CONDITIONS (for design purposes)		
a)	Annual mean if maximum monthly average temperature	50°C
b)	Annual mean if minimum monthly temperature	5°C
c)	Design ambient temperature	50°C
d)	Average Rainfall in mm	1500 mm
e)	Average thunderstorm days per year	77 days
f)	Maximum Relative humidity	100 %
g)	Average Relative humidity	85 %
h)	Height above mean sea level	Less than 1000 meters
i)	Pollution Severity	Heavily polluted
j)	Criteria for Wind Resistant design of structures and equipment	Standard Applicable - IS 875 (Part 3)
k)	Basic Wind speed "Vb" at ten meters above the mean ground level.	55m/ sec for Erasama 50 m/ sec for Duburi
l)	Risk Coefficient "K1"	1
m)	Seismic Co-efficient	0.06g Horizontal 0.01g Vertical

3.1.1 SYSTEM PARAMETERS

Sl.No.	Parameters	400 kV	220 kV	33 kV
1	Highest system voltage	420 kV rms	245 kVrms	36
2	System Frequency	50 Hz		
3	Variation in Frequency	+ - 2.5 %		
5	Lightning Impulse voltage	±1425kVp	± 1050kVp	170
6	Switching impulse voltage	±1050kVp	-	
7	Power frequency withstand for 1 min (rms)	630 kV (rms)	460 kV (rms)	70 kV (rms)
8	Max. fault level (3/1 sec.)	63 kA	50kA	31.5kA
9	Minimum creepage distance	13020 mm (Erasama) 10500 mm (Duburi)	7595mm (Erasama) -	1116mm (Erasama) 900mm (Duburi)
10	System Neutral Earthing	Effectively Earthed		
11	Corona Extinction Voltage	320kV	156kV	-
12	Radio Interference Voltage	500µV at 266kV	500µV at 167kV	-

3.1.2 AUXILIARY POWER

Nominal Voltage V	Variation	Frequency Hz or DC	Phase	Wires	Neutral Connection
430	±10%	50±5%	3	4	Solidly earthed
240	±10%	50±5%	1	2	Solidly earthed
220	187V - 242V	DC	DC	2	Isolated 2 wires
50	45V - 55V	DC	DC	2	+ve earthed

PROJECT: 2X500 MVA, 400/220 KV GIS S/S AT ERSAMA & ASSOCIATED 2 NOS 400 KV BAY EXTN AT DUBURI	
CUSTOMER: ODISHA POWER TRANSMISSION CORPORATION LIMITED (OPTCL)	
Technical Specification	TB-4-420-316-xxx Rev 00
Section-3: Project Details and General Specification	

3.1.3 The minimum electrical clearances for 400/220/33kV switchyard shall be as given below:

	400kV	220kV	33kV
Phase to earth clearance	3400 mm	2160mm	320mm
Phase to phase clearance	3900 mm	2160mm	320mm
Section clearance	6500 mm	5000mm	3000mm
Ground Clearance	8000 mm	5500mm	4000mm

3.2 INSTRUCTION TO BIDDERS:

The bidders shall furnish technical data sheets, catalogues, engineering data, technical information, design documents, drawings etc. fully in conformity with the technical specification.

The supplier should be approved by Employer (OPTCL). If not, it is the responsibility of the vendor to be assessed and approved by Employer, before placement of order by BHEL. Any cost involved in vendor assessment/approval must be borne by the vendor himself.

The Bidder's proposal shall be based upon the use of equipment and material complying fully with the requirements specified herein. It is recognized that the Bidder may have standardized on the use of certain components, materials, processes or procedures different than those specified herein. Alternate proposals offering similar equipment based on the manufacturer's standard practice will also be considered, provided the base offer is in line with technical specifications and such proposals meet the specified design standards and performance requirement and are acceptable to the Purchaser. Sufficient amount of information for justifying such proposals shall be furnished to Purchaser along with the bid to enable the Purchaser to determine the acceptability of these proposals.

Wherever a material or article is specified or defined by the name of a particular brand, Manufacturer or Vendor, the specific name mentioned shall be understood to be indicative of the function and quality desired and not restrictive. Other manufacturer's products may be considered provided sufficient information is furnished to enable the Employer to determine that the products proposed are equivalent to those named.

Equipment furnished shall be complete in every respect with all mountings, fittings, fixtures and standard accessories normally provided with such equipment and/ or needed for erection, completion and safe operation of the equipment as required by applicable codes, though they may not have been specifically detailed in the Technical Specifications unless included in the list of exclusions. Materials and components not specifically stated in the specification but which are necessary for commissioning and satisfactory operation of the switchyard unless specifically excluded shall be deemed to be included in the scope of the specification and shall be supplied without any extra cost. All similar standard components/parts of similar standard equipment under supply shall be inter-changeable with one another.

The bidder shall supply type tested (including special tests as per tech. specification) equipment and materials. The test reports shall be furnished by the bidder along with equipment/ material drawings. In the event of any discrepancy in the test reports, (i.e., if any test report is not acceptable due to any design/ manufacturing changes or due to non-compliance with the Technical Specification and/ or applicable standard), the tests shall be carried out without any additional cost implication to the BHEL. BHEL reserves the right to get any or all type/tests conducted/repeated.

PROJECT: 2X500 MVA, 400/220 KV GIS S/S AT ERSAMA & ASSOCIATED 2 NOS 400 KV BAY EXTN AT DUBURI	
CUSTOMER: ODISHA POWER TRANSMISSION CORPORATION LIMITED (OPTCL)	
Technical Specification	TB-4-420-316-xxx Rev 00
Section-3: Project Details and General Specification	

3.3 CODES AND STANDARDS

In addition to the codes and standards specifically mentioned in the relevant technical specifications for the equipment / plant / system, all equipment parts, systems and works covered under this specification shall comply with all currently applicable statutory regulations and safety codes of the Republic of India as well as of the locality where they will be installed.

Except where otherwise specified or implied, the bidder shall comply with the latest edition of the relevant Indian Standards, International Electrotechnical Commission (IEC) standards and any other standards mentioned in this Specification. The Bidder may submit for approval, equipment or materials conforming to technically equivalent National Standards. In such cases copies of the relevant Standards or part thereof, in the English language shall be submitted with the Tender.

In case of conflict the order of precedence shall be (1) IEC, (2) IS and (3) other alternative standard.

Reference to a particular standard or recommendation in this Specification does not relieve the Bidder of the necessity of providing the Contract Works complying with other relevant standards or recommendations.

The list of standards provided in the schedules of this Specification is not to be considered exhaustive and the Bidder shall ensure that equipment supplied under this contract meets the requirements of the relevant standard whether or not it is mentioned therein.

Other International/ National standards such as DIN, VDI, BS, GOST etc. shall also be accepted for only material codes and manufacturing standards, subject to the Employer's approval, for which the Bidder shall furnish, adequate information to justify that these standards are equivalent or superior to the standards mentioned above. In all such cases the Bidder shall furnish specifically the variations and deviations from the standards mentioned elsewhere in the specification together with the complete word to word translation of the standard that is normally not published in English.

3.4 LANGUAGE AND SYSTEM OF UNITS

The English language shall be used in all written communications between the Employer, the BHEL/OPTCL and the Bidder with respect to the services to be rendered and with respect to all documents and drawings procured or prepared by the Bidder pertaining to the work, unless otherwise agreed by the Employer.

It is required that danger plates, equipment designation labels or plates, instruction notices on plant and general substation notices be written in English, Hindi and Oriya. Control switch and lamp labels, indicator lamp and annunciator inscriptions shall be in English only.

The Bidder must furnish a schedule giving the English, Hindi and Oriya version of all labels, notices, etc., for approval.

The design features of all equipment shall be based on the SI system of units.

3.5 SERVICES TO BE PERFORMED BY THE EQUIPMENT BEING FURNISHED

The 400 kV system is being designed to limit the power frequency over voltage of 1.5 p.u. and the switching surge over voltage to 2.5 p.u. In 400 kV system the initial value of temporary over voltage could be 2.0 p.u. for 1-2 cycles. All the equipment/materials covered in this specification shall perform all its function satisfactorily without undue strain, restrike etc. under such over voltage conditions.

PROJECT: 2X500 MVA, 400/220 KV GIS S/S AT ERSAMA & ASSOCIATED 2 NOS 400 KV BAY EXTN AT DUBURI	
CUSTOMER: ODISHA POWER TRANSMISSION CORPORATION LIMITED (OPTCL)	
Technical Specification	TB-4-420-316-xxx Rev 00
Section-3: Project Details and General Specification	

All equipment shall also perform satisfactorily under various other electrical, electromechanical and meteorological conditions of the site of installation. All equipment shall be able to withstand all external and internal mechanical, thermal and electromechanical forces due to various factors like wind load, temperature variation, ice & snow (not applicable for this project), short circuit etc for the equipment.

3.6 CORRESPONDENCE, DRAWINGS, APPROVAL PROCEDURE AND SAMPLES

3.6.1 Drawings & Document Submission

All drawings submitted by the supplier including those submitted at the time of bid shall be in sufficient detail to indicate the type, size, arrangement, material description, Bill of Materials, weight of each component, break-up for packing and shipment, the external connections, fixing arrangement required. The dimensions required for installation and interconnections with other equipment and materials, clearances and spaces required for installation and interconnections between various portions of equipment and any other information specifically requested in the specifications.

Each drawing submitted by the bidder (including those of sub-vendors) shall bear project specific title block at the right hand bottom corner with clear mention of the name of the Employer, the system designation, the specifications title, the specification number, the name of the Project, drawing number and revisions. If standard catalogue pages are submitted, the applicable items shall be indicated therein. All titles, noting, markings and writings on the drawing shall be in English. All the dimensions should be in metric units.

All dimensions marked on drawings shall be considered correct although measurement by scale may differ from general arrangement drawings. Detailed drawings shall be worked to where they differ from general arrangement drawings.

All drawings for approval shall have the OPTCL-LOGO and the name of the Employer.

For presentation of design drawings and circuit documents IEC Publication 617 or equivalent standards for graphical symbols are to be followed.

The review of these document/data/drawings by the purchaser will cover only general conformance of the document/data/drawings to the specification and contract, interfaces with the equipment provided under specification, external connections and of the dimensions which might affect plan layout. This review by the purchaser may not indicate a thorough review of the dimensions, quantities and details of the equipment, material, any devices or items indicated or the accuracy of the information submitted. The review and/or approval by the purchaser shall not be considered by the bidder, as limiting any of his responsibilities and liabilities for mistakes and deviations from the requirements, specified under these specifications and documents.

All manufacturing, fabrication and execution of work in connection with the equipment/system prior to the approval of the drawings shall be at the bidder's risk. The bidder is expected not to make any changes in the design of the equipment /system, once they are approved by the Purchaser. However, if some changes are necessitated in the design of the equipment/system at a later date, the bidder may do so, but such changes shall promptly be brought to the notice of the Purchaser indicating the reasons for the change and get the revised drawing approved again in strict conformance to the provisions of the Technical Specification. Approval of bidder's drawing or work by the Purchaser shall not relieve the bidder of any of his responsibilities and liabilities under the Contract.

3.6.2 Bidder's Drawing Submission and Approval Procedure

PROJECT: 2X500 MVA, 400/220 KV GIS S/S AT ERSAMA & ASSOCIATED 2 NOS 400 KV BAY EXTN AT DUBURI	
CUSTOMER: ODISHA POWER TRANSMISSION CORPORATION LIMITED (OPTCL)	
Technical Specification	TB-4-420-316-xxx Rev 00
Section-3: Project Details and General Specification	

The following procedure for submission and review/approval of the drawings, data reports, information, etc. shall be followed by the bidder:

- a. All data/information furnished by Vendor in the form of drawings, documents, Catalogues or in any other form for Employer's information/interface and/or review and approval are referred by the general term "drawings".
- b. The 'Master drawings list' indicating titles, Drawing Number, Date of submission and approval etc. shall be furnished by the bidder. This list shall be updated if required at suitable interval during detailed engineering.
- c. All drawings (including those of sub-vendor) shall bear at the right hand bottom corner the 'title plate' with all relevant information duly filled in. The bidder shall furnish this format to his sub-vendor along with his purchase order for sub-vendor's compliance.
- d. Three copies of all drawings shall be submitted for approval and three copies for any subsequent revision. Employer shall forward their comments within four (4) weeks of receipt of drawings.
- e. The OPTCL/BHEL reserves the right to request any additional information that may be considered necessary in order to fully review the drawings. Drawings for approval shall be submitted as paper prints and shall bear the approved contract references.
- f. Upon review of each drawings, depending on the correctness and completeness of the drawings, the same will be categorised and approval accorded in one of the following categories:

CATEGORY I	Approved
CATEGORY II	Approved, subject to incorporation of comments/modification as noted. Resubmit revised drawing incorporating the comments
CATEGORY III	Not approved. Resubmit revised drawings for Approval after incorporating comments/modifications as noted
CATEGORY IV	For information and records

- g. Bidder shall resubmit the drawings approved under Category II, III within one (1) week of receipt of comments on the drawings, incorporating all comments. Every revision of the drawing shall bear a revision index wherein such revisions shall be highlighted in the form of description or marked up in the drawing identifying the same with relevant revision number enclosed in a triangle (e.g 1.2.3. etc.).
- h. In case Bidder does not agree with any specific comment, he shall furnish the explanation for the same to Employer for consideration. In all such cases Bidder shall necessarily enclose explanations along with the revised drawing (taking care of balance comments) to avoid any delay and/or duplication in review work.
- i. It is the responsibility of the Bidder to get all the drawings approved in the Category I or IV (as the case may be) and complete engineering activities within the agreed schedule. Any delay arising out of submission and modification of drawings shall not alter the contract completion schedule.
- j. Bidder shall not make any changes in the portions of the drawing other than those commented. If changes are required to be made in the portions already approved, the Bidder shall resubmit the drawings identifying the changes (along with reasons for changes) for Employer's review and approval. **Drawings resubmitted shall show clearly the portions where the same are revised marking the relevant revision numbers and Employer shall review only such revised portion of documents.**

PROJECT: 2X500 MVA, 400/220 KV GIS S/S AT ERSAMA & ASSOCIATED 2 NOS 400 KV BAY EXTN AT DUBURI	
CUSTOMER: ODISHA POWER TRANSMISSION CORPORATION LIMITED (OPTCL)	
Technical Specification	TB-4-420-316-xxx Rev 00
Section-3: Project Details and General Specification	

3.6.3 As Built Drawings

After completion of work on site all drawings shall be revised where necessary to show the equipment as installed and three copies submitted duly signed by site-in-charge. Following approval, two reproducible transparencies and twenty prints shall then be provided as required by the OPTCL/BHEL and shall be of sufficient detail to enable all parts to be identified. The bidder shall also submit, where possible, digitally stored copies of all as-built drawings on disc or CD-ROM in a format compatible with the Employer's drawing system.

Approval of drawings will not in any way relieve the Bidder of his obligations of furnishing the equipment in accordance with the specification and shall not prevent subsequent rejection if such equipment is later found to be defective.

3.6.4 Operation and Maintenance Manual

- a. The Bidder shall submit to the Employer preliminary instruction manuals for all the equipment for review. The final instructions manuals incorporating Employer's comments and complete in all respect shall be submitted at least sixty (60) days before the first shipment of the equipment. The instruction manuals shall contain full details and drawings of all the equipment, the transportation, storage, installation, testing, commissioning, operation and maintenance procedures, etc. separately for each component/equipment along with log record format. After approval by the Engg. In charge the Bidder shall deliver ten (10) copies of the complete manual.
- b. If after commissioning and initial operation of the plant, the instruction manuals require any modifications/additions/changes, the same shall be incorporated and the updated final instruction manuals shall be submitted.
- c. The operating and maintenance instructions together with drawings (other than shop drawings) of the equipment, as completed, shall have sufficient details to enable the Employer to maintain, dismantle, reassemble and adjust all parts of the equipment. They shall give a step by step procedure for all operations likely to be carried out during the life of the plant/equipment, including erection, testing, commissioning, operation, maintenance dismantling and repair. Each manual shall also include a complete set of approved drawings together with performance/rating curves of the equipment and test certificates, wherever applicable. The contract shall not be considered completed for purpose of taking over until such instructions and drawings have been supplied to the Employer.
- d. A separate section of the manual shall be for each size/type of equipment and shall contain a detailed description of construction and operation, together with all relevant pamphlets.
- e. The manuals shall include the following
 - a) List of spare parts along with their drawing and catalogues and procedure for ordering spares.
 - b) Lubrication Schedule including charts showing lubrication checking, testing and replacement procedure to be carried daily, weekly, monthly & at longer intervals to ensure trouble free operation.

The Contract shall not be considered to be completed for purposes of taking over until the final Instructions manuals (both erection and O & M manuals) have been supplied to the Employer.

3.6.5 Final Submission of drawings and documents

The Bidder shall furnish the following after approval of all drawings /documents and test reports:

- a. List of drawings bearing the Employer's and Bidder's drawing number.

PROJECT: 2X500 MVA, 400/220 KV GIS S/S AT ERSAMA & ASSOCIATED 2 NOS 400 KV BAY EXTN AT DUBURI	
CUSTOMER: ODISHA POWER TRANSMISSION CORPORATION LIMITED (OPTCL)	
Technical Specification	TB-4-420-316-xxx Rev 00
Section-3: Project Details and General Specification	

- b. Six (6) bound sets along-with two (2) sets of CD-ROMs/ DVD/Portable hard disk of all final drawings/documents.
- c. Bidder shall also furnish six (6) bound sets of all as-built drawings including the list of all as-built drawings bearing drawing numbers. The Bidder shall also furnish two (2) sets of CD-ROMs/ DVD/Portable hard disk of all as-built drawings as decided by the Employer.
- d. The Bidder shall also furnish four (4) copies and two (2) sets of CD-ROMs/ DVD/Portable hard disk of instruction/ operations & maintenance manuals (after approval) for all the equipment.

3.6.6 Test Reports

Two (2) copies of all test reports shall be supplied for approval before shipment of Equipment. The report shall indicate clearly the standard value specified for each test to facilitate checking of the reports. After final approval six (6) bound copies and two (2) sets of CD-ROMs/ DVD/Portable hard disk of all type and routine test reports shall be submitted to Employer.

3.7 MATERIAL /WORKMANSHIP

Where the specification does not contain references to workmanship, equipment, materials and components of the covered equipment, it is essential that the same must be new, of highest grade of the best quality of their kind, conforming to best engineering practice and suitable for the purpose for which they are intended and shall ensure satisfactory performance throughout the service life.

In case where the equipment, materials or components are indicated in the specification as “similar” to any special standard the purchaser shall decide upon the question of similarity. When required by the specification or when required by the purchaser the bidder shall submit, for approval, all the information concerning the materials or components to be used in manufacture. Machinery, equipment, materials and components supplied, installed or used without such approval shall run the risk of subsequent rejection, it being understood that the cost as well as the time delay associated with the rejection shall be borne by the Bidder.

The design of the Works shall be such that installation, future expansions, replacements and general maintenance may be undertaken with a minimum of time and expenses. Each component shall be designed to be consistent with its duty and suitable factors of safety subject to mutual agreements. All joints and fastenings shall be devised, constructed and documented so that the component parts shall be accurately positioned and restrained to fulfill their required function. In general, screw threads shall be standard metric threads. The use of other thread forms will only be permitted when prior approval has been obtained from the Purchaser.

Whenever possible, all similar part of the works shall be made to gauge and shall also be made interchangeable with similar parts. All spare parts shall also be interchangeable and shall be made of the same materials and workmanship as the corresponding parts of the equipment supplied under the specification. Where feasible, common component units shall be employed in different pieces of equipment in order to minimize spare parts stocking requirements. All equipment of the same type and rating shall be physically and electrically interchangeable.

The equipment offered in the bid only shall be accepted for supply, with the minimum modifications as agreed/accepted.

3.8 PROVISIONS FOR EXPOSURE TO HOT AND HUMID CLIMATE

PROJECT: 2X500 MVA, 400/220 KV GIS S/S AT ERSAMA & ASSOCIATED 2 NOS 400 KV BAY EXTN AT DUBURI	
CUSTOMER: ODISHA POWER TRANSMISSION CORPORATION LIMITED (OPTCL)	
Technical Specification	TB-4-420-316-xxx Rev 00
Section-3: Project Details and General Specification	

Outdoor equipment supplied under the specification shall be suitable for service and storage under tropical conditions of high temperature, high humidity' heavy rainfall and environment favorable to the growth of fungi and mildew. The indoor equipment located in non-air-conditioned areas shall also be of same type.

3.8.1 Space Heaters

Space heaters where provided shall be suitable for continuous operation at 240V supply voltage. On-off switch and fuse shall be provided.

One or more adequately rated permanently or thermostatically connected heaters shall be supplied to prevent condensation in any compartment. The heaters shall be installed in the lower portion of the compartment and electrical connections shall be made from below the heaters to minimise deterioration of supply wire insulation. The heaters shall be suitable to maintain the compartment temperature at approximately 10C, above the outside air temperature to prevent condensation. This shall be demonstrated by tests.

3.8.2 Fungi Static Varnish

Besides the space heaters, special moisture and fungus resistance varnish shall be applied on parts which may be subjected or predisposed to the formation of fungi due to the presence or deposit of nutrient substances. The varnish shall not be applied to any surface of part where the treatment will interfere with the operation or performance of the equipment. Such surfaces or parts shall be protected against the application of the varnish.

3.8.3 Ventilation Openings

In order to ensure adequate ventilation, compartments shall have ventilation openings provided with fine wire mesh of brass to prevent the entry of insects and to reduce to a minimum the entry of dirt and dust. Outdoor compartment openings shall be provided with shutter type blinds.

3.9 CLEANING, PAINTING AND TROPICALASATION

3.9.2 General

All paints shall be applied in strict accordance with the paint manufacturer's instructions.

All painting shall be carried out on dry and clean surfaces and under suitable atmospheric and other conditions in accordance with the paint manufacturer's recommendations.

An alternative method of coating equipment such as with epoxy resin-based coating powders will be permitted, subject to the approval of the Engg. In charge (Divisional Engr.), and such powders shall comply with the requirements of IEC 455. The Bidder shall provide full details of the coating process to the Engg. In charge (Divisional Engr.) for approval.

It is the responsibility of the Bidder to ensure that the quality of paints used shall withstand the tropical heat and extremes of weather conditions specified in the schedules. The paint shall not peel off, wrinkle, be removed by wind, storm and handling on site and the surface finish shall neither rust nor fade during the service life of the equipment.

The colors of paints for external and internal surfaces shall be in accordance with the approved color schemes.

PROJECT: 2X500 MVA, 400/220 KV GIS S/S AT ERSAMA & ASSOCIATED 2 NOS 400 KV BAY EXTN AT DUBURI	
CUSTOMER: ODISHA POWER TRANSMISSION CORPORATION LIMITED (OPTCL)	
Technical Specification	TB-4-420-316-xxx Rev 00
Section-3: Project Details and General Specification	

3.9.3 Works Painting Process

All steelworks, plant supporting steelworks and metalwork, except galvanised surfaces or where otherwise specified, shall be shot blasted to BS 7079 or the equivalent ISO standard. All sheet steel work shall be degreased, pickled, phosphated in accordance with the IS 6005 "Code of Practice for phosphating iron and sheet steel". All surfaces shall then be painted with one coat of epoxy zinc rich primer, two pack type, to a film thickness of 50 microns. This primer shall be applied preferably by airless spray and within twenty minutes but not exceeding one hour of shot blasting.

All rough surfaces of coatings shall be filled with an approved two pack filler and rubbed down to a smooth surface.

The interior surfaces of all steel tanks and oil filled chambers shall be shot blasted in accordance with BS 7079 or the equivalent ISO, and painted within a period of preferably twenty minutes, but not exceeding one hour with an oil resisting coating of a type and make to the approval of the BHEL/OPTCL.

The interior surfaces of mechanism chambers, boxes and kiosks, after preparation, cleaning and priming as required above, shall be painted with one coat zinc chromate primer, one coat phenolic based undercoating, followed by one coat phenolic based finishing paint to a light or white colour. For equipment for outdoor use this shall be followed by a final coat of anti-condensation paint of a type and make to the approval of the BHEL/OPTCL, to a light or white colour. A minimum overall paint film thickness of 150 microns shall be maintained throughout.

All steelworks and metalwork, except where otherwise specified, after preparation and priming as required above shall be painted with one coat metallic zinc primer and two coats of micaceous iron oxide paint followed by two coats of either phenolic based or enamel hard gloss finished coloured paint to the approval to an overall minimum paint film thickness of 150 microns.

Galvanised surfaces shall not be painted in the works.

All nuts, bolts, washers etc., which may be fitted after fabrication of the plant shall be painted as described above after fabrication.

The painted metal works shall be subjected to paint qualification test as per draft ANSI/IEEE-Std 37.21 - 1985 clause 5.2.5.

3.9.4 Colour Schemes

The Bidder shall propose a colour scheme for the sub-station for the approval of BHEL/OPTCL. The decision of BHEL/OPTCL shall be final. The scheme shall include:

- Finishing colour of indoor equipment
- Finishing colour of outdoor equipment
- Finish colour of all cubicles
- Finishing colour of various auxiliary system equipment including piping.
- Finishing colour of various building items.

All steel structures, plates etc. shall be painted with non-corrosive paint on a suitable primer. It may be noted that normally all Employer's electrical equipment in Employer's switchyard are painted with shade 631 of IS: 5 and Employer will prefer to follow the same for this project also. All indoor cubicles shall be of same colour scheme and for other miscellaneous items colour scheme will be subject to the approval of the BHEL/OPTCL.

PROJECT: 2X500 MVA, 400/220 KV GIS S/S AT ERSAMA & ASSOCIATED 2 NOS 400 KV BAY EXTN AT DUBURI
CUSTOMER: ODISHA POWER TRANSMISSION CORPORATION LIMITED (OPTCL)
Technical Specification TB-4-420-316-xxx Rev 00
Section-3: Project Details and General Specification

Sl. No.	Equipment	Application Environment			
		Indoor		Outdoor	
		Colour	Code IS:5	Colour	Code IS:5
400kV/220kV/132kV Class Equipment					
1	Transformers	—	—	Light grey	631
2	Marshalling boxes, CTs, PT's, CVT's, surge counter casings, junction boxes etc.	Light Admiralty grey.	697	Light Admiralty grey.	697
3	Control and relay panels, PLCC cabinets etc.	Smoke grey	692	—	—
4	Porcelain parts i.e. insulators	Dark brown	412	Dark brown	412
5	All structures/ metallic parts exposed to atmosphere	Hot dip galvanised			
33kV Class equipment					
6	Switchgear cubicles	Smoke grey	692	Light grey	631
7	Control and relay panels	Smoke grey	692	—	—
	LT switchgear				
8	LT switchgear exterior	Smoke grey	692	Light grey	631
9	ACDB/ MCC	Smoke grey	692	Light grey	631
10	DCDB	Smoke grey	692	—	—
11	LT bus duct in side enclosure	Matt Paint		—	—
12	LT bus duct outside enclosure	Smoke grey	692	—	—
13	Motors	Smoke grey	692	Light grey	631
14	Diesel generator engine	Smoke grey	692	—	—
15	Diesel generator	Smoke grey	692	—	—
16	LT transformers	Smoke grey	692	Light grey	631
17	Battery charger	Smoke grey	692	—	—
18	Mimic diagram				
	400kV	Dark violet	796	—	—
	220kV	Golden yellow	356	—	—
	132kV	Sky blue	101	—	—
	33kV	Signal red	537	—	—
	11kV	Canary yellow	309	—	—
	415V	Middle brown	411	—	—
	Miscellaneous				
19	Control modules and console inserts	Smoke grey	692	Light grey	631
20	Lighting package equipment outside	Light grey	631	Light grey	631
21	Lighting package equipment inside	Glossy white		Glossy white	
22	Water pipes	sea green	217	sea green	217
23	Air pipes	Sky blue	101	Sky blue	101
24	Transformer oil pipes	Light brown	410	Light brown	410
25	Fire Installations	Fire red	536	Fire red	536
26	Insulating oil/ gas treatment plant	Gulf red	473	Gulf red	473

Table 10.3.4. Recommended color schemes

3.10 DEGREES OF PROTECTION

Degrees of protection shall be provided in accordance with IEC 144 and IEC 529 and be as follows:

- For outdoor applications, IP 55.
- For indoor applications where purpose built accommodation is provided, e.g. switch and control and relay rooms in auxiliary plant buildings, IP 41.
- Where dust can adversely affect equipment within the enclosure, this equipment should be separately housed with a degree of protection of IP 51.

PROJECT: 2X500 MVA, 400/220 KV GIS S/S AT ERSAMA & ASSOCIATED 2 NOS 400 KV BAY EXTN AT DUBURI	
CUSTOMER: ODISHA POWER TRANSMISSION CORPORATION LIMITED (OPTCL)	
Technical Specification	TB-4-420-316-xxx Rev 00
Section-3: Project Details and General Specification	

- For indoor applications where the equipment is housed in the same building as that enclosing water and steam operated equipment, the degrees of protection stated in the previous paragraph shall be up-rated to IP 44 and IP 54 respectively.

Where more severe environments exist, e.g. steam and oil vapour or other deleterious chemical environments, special measures will be necessary and the degree of protection required will be specified separately.

The Bidder shall submit a schedule for providing the degree protection to various control boxes, junction boxes etc. for the BHEL/OPTCL's approval.

3.11 RATING PLATES, NAME PLATES AND LABELS

- All apparatus shall be clearly labelled indicating, where necessary, its purpose and service positions. Each phase of alternating current and each pole of direct current equipment and connections shall be coloured in an approved manner to distinguish phase or polarity.
- The material of all labels and the dimensions, legend, and method of printing shall be to approval. The surface of indoor labels shall have a matt or satin finish to avoid dazzle from reflected light.
- Colours shall be permanent and free from fading. Labels mounted on black surfaces shall have white lettering. „Danger“ plates shall have red lettering on a white background.
- All labels and plates for outdoor use shall be of non-corroding material. Where the use of enamelled iron plates is approved, the whole surface including the back and edges, shall be properly covered and resistant to corrosion. Protective washers of suitable material shall be provided front and back on the securing screws.
- Labels shall be engraved in Hindi, English and Oriya. Name plates shall be white with black engraved lettering and shall carry all the applicable information specified in the applicable items of the Standards.
- Any other relevant information which may be required for groups of smaller items for which this is not possible e.g. switch bays etc. a common name plate in Oriya with the title and special instructions on it shall be provided.
- No scratching, corrections or changes will be allowed on name plates.
- All equipment mounted on front and rear sides as well as equipment mounted inside the panels shall be provided with individual name plates with equipment designation engraved.
- On the top of each panel on front as well as rear sides large name plates with bold size lettering shall be provided for circuit/ feeder/ cubicle box designation.
- All front mounted equipment shall be also provided, at the rear, with individual name plates engraved with tag numbers corresponding to the one shown in the panel internal wiring to facilitate tracing of the wiring. The name plates shall be mounted directly by the side of the respective equipment wiring.
- Name plates of cubicles and panels may be made of non rusting metal or 3 ply lamicaid. These name plates may be black with white engraved lettering.

PROJECT: 2X500 MVA, 400/220 KV GIS S/S AT ERSAMA & ASSOCIATED 2 NOS 400 KV BAY EXTN AT DUBURI	
CUSTOMER: ODISHA POWER TRANSMISSION CORPORATION LIMITED (OPTCL)	
Technical Specification	TB-4-420-316-xxx Rev 00
Section-3: Project Details and General Specification	

- l) The name plate inscription and size of name plates and letters shall be submitted to the BHEL/OPTCL/ Engineer for approval.
- m) The nameplates of the apparatus shall include, at least, the information listed below, together with any other relevant information specified in the applicable standards:
 - Concise descriptive title of the equipment
 - Rating and circuit diagrams
 - Manufacturer's name, trade-mark, model type, serial number
 - Instruction book number
 - Year of manufacture
 - Total weight (for capacitor racks indicate weight, for capacitors indicate quantity of liquid)
 - Special instructions, if any, about storage, transportation, handling etc.
- n) Each measuring instrument and meter shall be prominently marked with the quantity measured e.g. kV, A, MW etc. All relays and other devices shall be clearly marked with manufacturers name, manufacturer's type, serial number and electrical rating data.
- o) Danger plates and plates for phase colours shall be provided as per requirement. The Bidder shall devise a system to designate equipment and sub-systems. The nameplates/labels displaying these designations shall be installed at appropriate locations. Whenever motion or flow of fluids is involved, plates showing direction of motion or flow shall also be provided.

3.12 BOLTS AND NUTS

All bolts, studs, screw threads, pipe threads, bolt heads and nuts shall comply with the appropriate national standards for metric threads, or the technical equivalent.

Except for small wiring, current carrying terminal bolts or studs, for mechanical reasons, shall not be less than 6 mm in diameter.

All nuts and pins shall be adequately locked. Wherever possible bolts shall be fitted in such a manner that in the event of failure of locking resulting in the nuts working loose and falling off, the bolt will remain in position.

All bolts, nuts and washers placed in outdoor positions shall be treated to prevent corrosion, by hot dip galvanising or electro galvanising to service condition 4. Appropriate precautions shall be taken to prevent electrolytic action between dissimilar metals.

Where bolts are used on external horizontal surfaces where water can collect, methods of preventing the ingress of moisture to the threads shall be provided.

Each bolt or stud shall project at least one thread but not more than three threads through its nut, except when otherwise approved for terminal board studs or relay stems. If bolts and nuts are placed so that they are inaccessible by means of ordinary spanners, special spanners shall be provided.

The length of the screwed portion of the bolts shall be such that no screw thread may form part of a shear plane between members. Taper washers shall be provided where necessary.

Protective washers of suitable material shall be provided front and back on the securing screws.

PROJECT: 2X500 MVA, 400/220 KV GIS S/S AT ERSAMA & ASSOCIATED 2 NOS 400 KV BAY EXTN AT DUBURI	
CUSTOMER: ODISHA POWER TRANSMISSION CORPORATION LIMITED (OPTCL)	
Technical Specification	TB-4-420-316-xxx Rev 00
Section-3: Project Details and General Specification	

3.13 GALVANISING:

3.13.1 General

All machining, drilling, welding, engraving, scribing or other manufacturing activities which would damage the final surface treatment shall be completed before the specified surface treatment is carried out.

3.13.2 Galvanising

All metal surfaces shall be subjected to treatment for anti-corrosion protection. All ferrous surfaces for external use shall be hot dip galvanised. High tensile steel nuts, bolts and spring washers shall be electro galvanised to service condition 4. All steel conductors including those used for earthing and grounding (above ground level) shall also be galvanised according to IS 2629.

All galvanising shall be applied by the hot dip process and shall comply with IS 2629, IS 2633, IS 4759, IS 1367 or IS 6745.

All welds shall be de-scaled, all machining carried out and all parts shall be adequately cleaned prior to galvanising. The preparation for galvanising and the galvanising itself shall not adversely affect the mechanical properties of the coated material.

The threads of all galvanised bolts and screwed rods shall be cleared of spelter by spinning or brushing. A die shall not be used for cleaning the threads unless specially approved by the BHEL/OPTCL. All nuts shall be galvanised with the exception of the threads which shall be oiled. Surfaces which are in contact with oil shall not be galvanised or cadmium plated.

Partial immersion of the work will not be permitted and the galvanising tank must therefore be sufficiently large to permit galvanising to be carried out by one immersion.

Galvanising of wires shall be applied by the hot dip process and shall meet the requirements of IS 2141.

The minimum weight of the zinc coating and minimum thickness of coating for outdoor equipment shall be as follows:

a) For sections & plates above 5mm of thickness	910 gm/sq.m	127 microns
b) For sections & plates below 5mm of thickness	610 gm/sq.m	87 microns
c) For surfaces embedded in concrete	800 gm/sq.m.	

The galvanised surfaces shall consist of a continuous and uniform thick coating of zinc, firmly adhering to the surface of steel. The finished surface shall be clean and smooth and shall be free from defects such as discoloured patches, bare spots, unevenness of coating, spelter which is loosely attached to the steel globules, spiky deposits, blistered surface, flaking or peeling off, etc. The presence of any of these defects noticed on visual or microscopic inspection shall render the material liable to rejection.

After galvanising no drilling or welding shall be performed on the galvanised parts of the equipment excepting that nuts may be threaded after galvanising. Sodium dichromate treatment shall be provided to avoid formation of white rust after hot dip galvanisation.

The galvanised steel shall be subjected to six one minute dips in copper sulphate solution as per IS 2633.

PROJECT: 2X500 MVA, 400/220 KV GIS S/S AT ERSAMA & ASSOCIATED 2 NOS 400 KV BAY EXTN AT DUBURI	
CUSTOMER: ODISHA POWER TRANSMISSION CORPORATION LIMITED (OPTCL)	
Technical Specification	TB-4-420-316-xxx Rev 00
Section-3: Project Details and General Specification	

Sharp edges with radii less than 2.5 mm shall be able to withstand four immersions of the Standard Preece test. All other coatings shall withstand six immersions. The following galvanising tests should essentially be performed as per relevant Indian Standards.

- Coating thickness
- Uniformity of zinc
- Adhesion test
- Mass of zinc coating

Galvanised material must be transported properly to ensure that galvanised surfaces are not damaged during transit. Application of zinc rich paint at site shall not be allowed.

3.14 CLAMPS AND CONNECTORS INCLUDING TERMINAL CONNECTORS

The terminal connectors shall conform strictly to the requirements if the latest versions of following standards as amended up-to-date, except otherwise,

- | | | |
|------|----------|---|
| i) | IS: 5561 | Power Connectors |
| ii) | IS: 617 | Aluminium & Aluminium Alloy |
| iii) | IS: 2629 | Recommended Practice for HDG of iron & steel |
| iv) | IS: 2633 | Method of testing uniformity of coating of zinc coated articles |

The material of clamps and connectors shall be Aluminium alloy casting conforming to designation A6 of IS: 617 for connecting to equipment terminals and conductors of aluminium. In case the terminals are of copper, the same clamps/connectors shall be used with 4mm thick bimetallic liner.

The material of clamps and connectors shall be Galvanised mild steel for connecting to shield wire.

Bolts, nuts and plain washers shall be hot dip galvanised mild steel for sizes M12 and above. For sizes below M12, they shall be electro-galvanised mild steel. The spring washers shall be electro-galvanised mild steel.

All castings shall be free from blow holes, surface blisters, cracks and cavities. All sharp edges and corners shall be rounded off to meet specified corona and radio interference requirements.

They shall have same current rating as that of the connected equipment. All current carrying parts shall be at least 10 mm thick. The connectors shall be manufactured to have minimum contact resistance.

Flexible connectors, braids or laminated strips shall be made up of copper/aluminium.

Current rating and size of terminal/conductor for which connector is suitable shall be put on a suitable sticker on each component which should last at least till erection time.

3.15 CABLE GLANDS AND LUGS/FERRULES

Cable shall be terminated using double compression type cable glands. Testing requirements of Cable glands shall conform to BS:6121 and gland shall be of robust construction capable of clamping cable and cable armour (for armoured cables) firmly without injury to insulation. Cable glands shall be made of heavy duty brass machine finished and nickel chrome plated. Thickness of plating shall not be less than 10 micron. All washers and hardware shall also be made of brass with nickel chrome plating Rubber components shall be of neoprene or better synthetic material and of tested quality. Cable glands shall be suitable for the sizes of cable supplied/erected.

PROJECT: 2X500 MVA, 400/220 KV GIS S/S AT ERSAMA & ASSOCIATED 2 NOS 400 KV BAY EXTN AT DUBURI	
CUSTOMER: ODISHA POWER TRANSMISSION CORPORATION LIMITED (OPTCL)	
Technical Specification	TB-4-420-316-xxx Rev 00
Section-3: Project Details and General Specification	

When connections rated at 380 volt and above are taken through junction boxes they shall be adequately screened and "DANGER" notices shall be affixed to the outsides of junction boxes or marshalling kiosk. Where connections to other equipment and supervisory equipment are required the connections shall be grouped together.

3.16.2 LV power cabling

LVAC cable terminals shall be provided with adequately sized, hot pressed, cast or crimp type lugs. Where sweating sockets are provided they shall be without additional clamping or pinch bolts. Where crimp type lugs are provided they shall be applied with the correct tool and the crimping tool shall be checked regularly for correct calibration. Bi-metallic joints between the terminals and lugs shall be provided where necessary.

Terminals shall be marked with the phase colour in a clear and permanent manner.

A removable gland plate shall be provided by the Bidder. The Bidder shall be responsible for drilling the cable gland plate. ere

Armoured cables shall be provided with suitable glands for terminating the cable armour and shall be provided with an earthing ring and lug to facilitate connection of the gland to the earth bar.

3.17 PRODUCTION PROCESS REQUIREMENTS

3.17.1 CASTINGS

GENERAL

All castings shall be true to pattern, free from defects and of uniform quality and condition. The surfaces of castings which do not undergo machining, shall be free from foundry irregularities. The castings shall be subject to NDT, chemical, mechanical and metallographic tests. Details of the same shall be furnished to BHEL/OPTCL for review/approval. Magnetic particle inspection (MPI) test, wherever applicable, shall be carried out in longitudinal and transverse direction to detect radial and axial cracks.

IRON CASTINGS

Iron casting material shall be in accordance with ASTM A 126 Class B. A copy of the ladle analysis shall be sent to the BHEL/OPTCL. Each casting shall have a test bar from which tension test specimens may be taken. Test specimen shall be in accordance with ASTM A 370 and tested in accordance with ASTM E8. The Bidder shall submit his procedures for testing and acceptance for iron castings for approval by the BHEL/OPTCL.

STEEL CASTINGS

Steel castings shall be manufactured in accordance with ASTM A 27 and shall be subjected to appropriate tests and inspection as detailed herein.

Copies of mandatory documentation, such as ladle analyses and mechanical test results, shall be sent to the BHEL/OPTCL. (Non-ferrous casting material and castings shall be manufactured in accordance with the appropriate ASTM standards for the material concerned).

3.17.2 FORGINGS

When requested by the BHEL/OPTCL, forgings will be subjected to inspection in the regions of fillets and changes of section by suitable method. Magnetic particle, dye-penetration, radiographic or ultrasonic, or any combination of these methods may be used to suit material type and forging design.

The testing is to be carried out after the rough machining operation and is to be conducted according to the appropriate ASTM standards.

MPI test on forging shall be carried out to detect both radial and axial cracks. Ferrous forgings shall be demagnetised after such tests.

PROJECT: 2X500 MVA, 400/220 KV GIS S/S AT ERSAMA & ASSOCIATED 2 NOS 400 KV BAY EXTN AT DUBURI	
CUSTOMER: ODISHA POWER TRANSMISSION CORPORATION LIMITED (OPTCL)	
Technical Specification	TB-4-420-316-xxx Rev 00
Section-3: Project Details and General Specification	

Any indentations which prove to penetrate deeper than 2.5% of the finished thickness of the forging shall be reported to the BHEL/OPTCL giving location, length, width and depth. Any indentations which will not machine out during final machining shall be gouged out and repaired using an approved repair procedure. Repair of rotating elements by welding will only be accepted subject to detailed examination of the proposal by the BHEL/OPTCL prior to the repair being carried out. The forging shall be tested for mechanical and metallographic tests as per ASTM. The details shall be mutually discussed/agreed upon.

3.17.3 FABRICATED COMPONENTS

All components machined or fabricated from plate, sheet or bar stock shall meet the material requirements of ASTM or material specification approved by the BHEL/OPTCL.

Structural steel, rolled shapes, bars, etc. shall comply with the latest ASTM for A36.

Plate steel shall be of a designation and quality suitable for the function it is intended to perform. Insofar as it is compatible with its function, it shall comply with ASTM A283 structural quality.

All, or a representative number of such components, shall be subjected to one or more of the following tests: visual, dye penetration, magnetic particle (transverse and longitudinal), ultrasonic or radiographic. These tests shall be in accordance with the recommended practices of the ASTM. The terms of reference for acceptance shall be the applicable ASTM Specifications.

3.17.4 WELDING AND WELDERS QUALIFICATIONS

General

All welding shall be carried out by qualified welders only.

All welding shall be in accordance with the corresponding standards of the American Welding Society or the American Society of Mechanical Engineers.

Other standards to determine the quality of welding process and qualifications of welders may be considered, provided that sufficient information is first submitted for the approval of the BHEL/OPTCL.

Prior to the start of fabrication, the Bidder shall submit to the BHEL/OPTCL for approval, a description of each of the welding procedures which he proposes to adopt, together with certified copies of reports of the results from tests made in accordance with these procedures.

The Bidder shall be responsible for the quality of the work performed by his welding organisation. All welding operators, to be assigned work, including repair of casting, shall pass the required tests for qualification of welding procedures and operators. The BHEL/OPTCL reserves the right to witness the qualification tests for welding procedures and operators and the mechanical tests at the samples.

The Bidder shall bear all his own expenses in connection with the qualification tests. If the work of any operator at any time appears questionable, such operator will be required to pass appropriate prequalification tests as specified by the Inspector and at the expense of the Bidder.

Welding

All welding shall be performed in accordance with the appropriate standards. The design and construction of welded joints subject to hydraulic pressure shall conform to the applicable requirement of ASME "Boiler and Pressure Vessel Code" shall be qualified in accordance with Section IX of this Code. The design and construction of welded joints not subjected to hydraulic pressure shall, as a minimum, conform to the requirements of AWS "Specification for Welded Highway and Railway Bridge" D2.0. Except for minor parts and items specifically exempted from stress relieving, all shop welded joints shall be stress relieved in accordance with the requirements of the ASME "Boiler and Pressure Vessel Code" Section VIII.

In addition to satisfying the procedural and quality requirements set forth in the applicable code and/or these Specifications, all welding shall meet the following requirements for workmanship and visual quality:

- Butt welds shall be slightly convex, of uniform height and shall have full penetration.
- Fillet welds shall be of the specified size, with full throat and legs of equal length.

PROJECT: 2X500 MVA, 400/220 KV GIS S/S AT ERSAMA & ASSOCIATED 2 NOS 400 KV BAY EXTN AT DUBURI	
CUSTOMER: ODISHA POWER TRANSMISSION CORPORATION LIMITED (OPTCL)	
Technical Specification	TB-4-420-316-xxx Rev 00
Section-3: Project Details and General Specification	

- Repairing, chipping and grinding of welds shall be done in a manner which will not gouge, groove or reduce the thickness of the base metal.
- The edges of the member to be joined shall expose sound metal, free from laminations, surface defects caused by shearing or flame-cutting operations or other injurious defects.

Welded joints subject to critical working stress shall be tested by approved methods of non-destructive testing, such as radiographic and ultrasonic examination, magnetic particle and liquid penetration inspection. All expenses in connection with these tests shall be borne by the Bidder. The extent of testing shall be as stipulated by the ASME „Boiler and Pressure Vessel Code”, Section VIII, but without prejudice to the rights of the Inspector or the BHEL/OPTCL to ask for additional tests,

The arc-welding process to be used and the welding qualifications of the welders employed on the work shall be used in accordance with AWS requirements and Section VIII and IX of the ASME (American Society of Mechanical Engineers) Code, latest edition, as they may apply. All welding rods shall conform to the requirements of the latest issue of Section It, part C of the ASME Code.

Gas shielded welding (TIG or MIG) used as appropriate for aluminium, stainless steel or other material shall be carried out in accordance with the best commercial practice and the following standard specifications:

- Specifications for copper and copper-alloy welding rods (AWS A5.7, ASTM B259)
- Specification for corrosion-resisting chromium and chromium-nickel steel welding rods and bare electrodes (AWS A5.9, ASTM A371)
- Specifications for aluminium and aluminium alloy rods and bare electrodes (AWS A5.10, ASTM B285).
- Specifications for nickel and nickel-base alloy bare welding filler metal (AWS A5.14, ASTM B304).

Gas welding will not normally be used in the equipment. When a particular equipment manufacture requires the use of gas welding, the proposed process and the welder’s qualification shall be in accordance with AWS B3.0.

Welding of galvanised components will not be allowed in the equipment.

Strict measures of quality control shall be exercised throughout the Equipment/ Works. The BHEL/OPTCL may call for an adequate NDT test of the work of any operator, who in his opinion is not maintaining the standard of workmanship. Should this NDT test prove defective, all work done by that operator, since his last test shall be tested at the Bidder’s expense. If three or more of these tests prove defective, the operator shall be removed from the project.

A procedure for the repair of defects shall be submitted to the BHEL/OPTCL for his approval prior to any repairs being made.

Welding of pipes

Before welding, the ends shall be cleaned by wire brushing, filing or machine grinding. Each weld-run shall be cleaned of slag before the next run is deposited.

Welding at any joint shall be completed uninterrupted. If this cannot be followed for some reason, the weld shall be insulated for slow and uniform cooling.

Welding shall be done by manual oxy-acetylene or manual shielded metal arc process. Automatic or semi-automatic welding processes may be done only with the specific approval of BHEL/OPTCL.

As far as possible welding shall be carried out in flat position. If not possible, welding shall be done in a position as close to flat position as possible.

Downward technique is not allowed while welding pipes in horizontal position, unless permitted by the BHEL/OPTCL.

Combination of welding processes or usage of electrodes of different classes or makes in a particular joint shall be allowed only after the welding procedure has been duly qualified and approved by the BHEL/OPTCL.

No backing ring shall be used for circumferential butt welds.

Welding carried out in ambient temperature of 5C or below shall be heat treated.

PROJECT: 2X500 MVA, 400/220 KV GIS S/S AT ERSAMA & ASSOCIATED 2 NOS 400 KV BAY EXTN AT DUBURI	
CUSTOMER: ODISHA POWER TRANSMISSION CORPORATION LIMITED (OPTCL)	
Technical Specification	TB-4-420-316-xxx Rev 00
Section-3: Project Details and General Specification	

A spacer wire of proper diameter may be used for weld root opening but must be removed after tack welding and before applying root run.

Tack welding for the alignment of pipe joints shall be done only by qualified welders. Since tack welds form part of final welding, they shall be executed carefully and shall be free from defects. Defective welds shall be removed prior to the welding of joints.

Electrodes size for tack welding shall be selected depending upon the root opening.

Tack welds should be equally spaced.

Root run shall be made with respective electrodes/filler wires. The size of the electrodes shall not be greater than 3.25 mm (10 SWG) and should preferably be 2.3 mm (12 SWG). Welding shall be done with direct current values recommended by the electrode manufacturers.

Upward technique shall be adopted for welding pipes in horizontally fixed position. For pipes with wall thickness less than 3 mm, oxyacetylene welding is recommended.

The root run of butt joints shall be such as to achieve full penetration with the complete fusion of root edges. The weld projection shall not exceed 3 mm inside the pipe.

On completion of each run craters, weld irregularities, slag etc. shall be removed by grinding or chipping. During the process of welding, all movements, shocks, vibration or stresses shall be carefully avoided in order to prevent weld cracks.

Fillet welds shall be made by shielded metal arc process regardless of thickness and class of piping. Electrode size shall not exceed 10 SWG. (3.25 mm). At least two runs shall be made on socket weld joints.

3.18 QUALITY ASSURANCE

3.18.1 GENERAL

To ensure that the supply and services under the scope of this Contract, whether manufactured or performed within the Bidder's works or at his Sub-Bidder's premises or at Site or at any other place of work are in accordance with the Specification, with the Regulations and with relevant Indian or otherwise Authorized Standards the Bidder shall adopt suitable Quality Assurance Programs and Procedures to ensure that all activities are being controlled as necessary.

The quality assurance arrangements shall conform to the relevant requirements of ISO 9001 or ISO 9002 as appropriate.

Manufacturing Quality Plan will detail out for all the components and equipment, various tests/inspection, to be carried out as per the requirements of this specification and standards mentioned therein and quality practices and procedures followed by Bidder's/ Sub-bidder's/ sub-supplier's Quality Control Organisation, the relevant reference documents and standards, acceptance norms, inspection documents raised etc., during all stages of materials procurement, manufacture, assembly and final testing/performance testing. The Quality Plan shall be submitted on electronic media e.g. E-mail in addition to hard copy, for review. Once the same is finalised, hard copies shall be submitted for approval. After approval the same shall be submitted in compiled form on CD ROM.

The Bidder shall also furnish copies of the reference documents/plant standards/acceptance norms/tests and inspection procedure etc., as referred in Quality Plans along with Quality Plans. These Quality Plans and reference documents/standards etc. will be subject to Employer's approval without which manufacturer shall not proceed.

These approved documents shall form a part of the contract. In these approved Quality Plans, Employer shall identify customer hold points (CHP), i.e. test/checks which shall be carried out in presence of the Employer's Project Manager or his authorised representative and beyond which the work will not proceed without consent of Employer/Authorised representative in writing. All deviations to this specification,

PROJECT: 2X500 MVA, 400/220 KV GIS S/S AT ERSAMA & ASSOCIATED 2 NOS 400 KV BAY EXTN AT DUBURI	
CUSTOMER: ODISHA POWER TRANSMISSION CORPORATION LIMITED (OPTCL)	
Technical Specification	TB-4-420-316-xxx Rev 00
Section-3: Project Details and General Specification	

approved quality plans and applicable standards must be documented and referred to Employer along with technical justification for approval and dispositioning.

No material shall be despatched from the manufacturer's works before the same is accepted subsequent to pre-despatch final inspection including verification of records of all previous tests/inspections by Employer's Project Manager/Authorised representative and duly authorised for despatch by issuance of Material Dispatch Clearance Certificate (MDCC).

All material used for equipment manufacture including casting and forging etc. shall be of tested quality as per relevant codes/standards. Details of results of the tests conducted to determine the mechanical properties, chemical analysis and details of heat treatment procedure recommended and actually followed shall be recorded on certificates and time temperature chart. Tests shall be carried out as per applicable material standards and/or agreed details.

For all spares and replacement items, the quality requirements as agreed for the main equipment supply shall be applicable.

Repair/rectification procedures to be adopted to make the job acceptable shall be subject to the approval of the Employer/ authorised representative.

3.18.2 SUB-VENDOR

The Bidder shall ensure that the Quality Assurance requirements of this Specification are followed by any sub-vendor appointed by him under the Contract.

The Bidder shall assess the sub-vendor's Quality Assurance arrangements prior to his appointment to ensure its compliance with the appropriate ISO 9000 standard and the Specification.

Auditing of the sub-vendor's Quality Assurance arrangements shall be carried out by the Bidder and recorded in such a manner that demonstrates to the OPTCL/BHEL the extent of the audits and their effectiveness.

3.18.3 QUALITY ASSURANCE DOCUMENTS

The Bidder shall be required to submit two hard copies and two sets on CDROM of the following Quality Assurance Documents as identified in respective quality plan with tick (v) mark.

Each QA Documentation shall have a project specific Cover Sheet bearing name & identification number of equipment and including an index of its contents with page control on each document.

The QA Documentation file shall be progressively completed by the Supplier's sub-supplier to allow regular reviews by all parties during the manufacturing.

The final quality document will be compiled and issued at the final assembly place of equipment before dispatch. However CD-Rom may be issued not later than three weeks.

Typical contents of Quality Assurance Document are as below:-

- i) Quality Plan,
- ii) Material mill test reports on components as specified by the specification and approved Quality Plans.
- iii) Manufacturer / works test reports/results for testing required as per applicable codes and standard referred in the specification and approved Quality Plans.

PROJECT: 2X500 MVA, 400/220 KV GIS S/S AT ERSAMA & ASSOCIATED 2 NOS 400 KV BAY EXTN AT DUBURI	
CUSTOMER: ODISHA POWER TRANSMISSION CORPORATION LIMITED (OPTCL)	
Technical Specification	TB-4-420-316-xxx Rev 00
Section-3: Project Details and General Specification	

- iv) Non-destructive examination results /reports including radiography interpretation reports. Sketches/drawings used for indicating the method of traceability of the radiographs to the location on the equipment.
- v) Heat Treatment Certificate/Record (Time- temperature Chart)
- vi) All the accepted Non-conformance Reports (Major/Minor) / deviation, including complete technical details / repair procedure).
- vii) CHP / Inspection reports duly signed by the Inspector of the Employer and Bidder for the agreed Customer Hold Points.
- viii) Certificate of Conformance (COC) whoever applicable.
- ix) MDCC

Before dispatch/ commissioning of any equipment, the Supplier shall make sure that the corresponding quality document or in the case of protracted phased deliveries, the applicable section of the quality document file is completed. The supplier will then notify the Inspector regarding the readiness of the quality document (or applicable section) for review.

- i) If the result of the review carried out by the Inspector of the Quality document (or applicable section) is satisfactory, the Inspector shall stamp the quality document (or applicable section) for release.
- ii) If the quality document is unsatisfactory, the Supplier shall endeavour to correct the incompleteness, thus allowing to finalize the quality document (or applicable section) by time compatible with the requirements as per contract documents. When it is done, the quality document (or applicable section) is stamped by the Inspector.
- iii) If a decision is made for dispatch, whereas all outstanding actions cannot be readily cleared for the release of the quality document by that time, the supplier shall immediately, upon shipment of the equipment, send a copy of the quality document Review Status signed by the Supplier Representative to the Inspector and notify of the committed date for the completion of all outstanding actions & submission. The Inspector shall stamp the quality document for applicable section when it is effectively completed. The submission of QA documentation package shall not be later than 3 weeks after the dispatch of equipment.

3.18.4 TRANSMISSION OF QUALITY DOCUMENTS

As a general rule, two hard copies of the quality document and Two CD ROMs shall be issued to the Employer on release of QA Documentation by Inspector. One set of quality document shall be forwarded to Corporate Quality Assurance Department and other set to respective Site.

For the particular case of phased deliveries, the complete quality document to the Employer shall be issued not later than 3 weeks after the date of the last delivery similarly as stated above.

3.18.5 INSPECTION, TESTING & INSPECTION CERTIFICATE

- i. The word 'Inspector' shall mean the Project Manager and/or his authorised representative and/or an outside inspection agency acting on behalf of the Employer to inspect and examine the materials and workmanship of the works during its manufacture or erection.
- ii. The Project Manager or his duly authorised representative and/or an outside inspection agency acting on behalf of the Employer shall have access at all reasonable times to inspect and examine the materials and workmanship of the works during its manufacture or erection and if part of the works is being manufactured or assembled on other premises or works, the Bidder shall obtain for the Project Manager and for his duly authorised representative permission to inspect as if the works were manufactured or assembled on the Bidder's own premises or works.

PROJECT: 2X500 MVA, 400/220 KV GIS S/S AT ERSAMA & ASSOCIATED 2 NOS 400 KV BAY EXTN AT DUBURI	
CUSTOMER: ODISHA POWER TRANSMISSION CORPORATION LIMITED (OPTCL)	
Technical Specification	TB-4-420-316-xxx Rev 00
Section-3: Project Details and General Specification	

- iii. The Bidder shall give the Project Manager/Inspector fifteen (15) days written notice of any material being ready for testing. Such tests shall be to the Bidder's account except for the expenses of the Inspector's. The Project Manager/Inspector, unless the witnessing of the tests is virtually waived and confirmed in writing, will attend such tests within fifteen (15) days of the date on which the equipment is noticed as being ready for test/inspection failing which the Bidder may proceed with test which shall be deemed to have been made in the inspector's presence and he shall forthwith forward to the inspector duly certified copies of test reports in two (2) copies.
- iv. The Project Manager or Inspector shall within fifteen (15) days from the date of inspection as defined herein give notice in writing to the Bidder, or any objection to any drawings and all or any equipment and workmanship which is in his opinion not in accordance with the contract. The Bidder shall give due consideration to such objections and shall either make modifications that may be necessary to meet the said objections or shall inform in writing to the Project Manager/Inspector giving reasons therein, that no modifications are necessary to comply with the contract.
- v. When the factory tests have been completed at the Bidder's or sub-bidder's works, the Project Manager /Inspector shall issue a certificate to this effect fifteen (15) days after completion of tests but if the tests are not witnessed by the Project Manager /Inspectors, the certificate shall be issued within fifteen (15) days of the receipt of the Bidder's test certificate by the Project Manager /Inspector. Project Manager /Inspector to issue such a certificate shall not prevent the Bidder from proceeding with the works. The completion of these tests or the issue of the certificates shall not bind the Employer to accept the equipment should it, on further tests after erection be found not to comply with the contract.
- vi. In all cases where the contract provides for tests whether at the premises or works of the Bidder or any sub-bidder, the Bidder, except where otherwise specified shall provide free of charge such items as labour, material, electricity, fuel, water, stores, apparatus and instruments as may be reasonably demanded by the Project Manager /Inspector or his authorised representatives to carry out effectively such tests on the equipment in accordance with the Bidder and shall give facilities to the Project Manager/Inspector or to his authorised representative to accomplish testing.
- vii. The inspection by Project Manager / Inspector and issue of Inspection Certificate thereon shall in no way limit the liabilities and responsibilities of the Bidder in respect of the agreed Quality Assurance Programme forming a part of the contract.
- viii. To facilitate advance planning of inspection in addition to giving inspection notice, the Bidder shall furnish quarterly inspection programme indicating schedule dates of inspection at Customer Hold Point and final inspection stages. Updated quarterly inspection plans will be made for each three consecutive months and shall be furnished before beginning of each calendar month.
- ix. All inspection, measuring and test equipment used by bidder shall be calibrated periodically depending on its use and criticality of the test/measurement to be done. The Bidder shall maintain all the relevant records of periodic calibration and instrument identification, and shall produce the same for inspection by NTPC. Wherever asked specifically, the bidder shall re-calibrate the measuring/test equipment in the presence of Project Manager / Inspector.

3.19 TYPE, ROUTINE & ACCEPTANCE TESTS:

The Bidder shall carry out the tests stated in accordance with the conditions of this Specification, without extra charge for such additional tests as in the opinion of the BHEL/OPTCL are necessary to determine that the Contract Works comply with this Specification. The tests shall be carried out generally in accordance

PROJECT: 2X500 MVA, 400/220 KV GIS S/S AT ERSAMA & ASSOCIATED 2 NOS 400 KV BAY EXTN AT DUBURI	
CUSTOMER: ODISHA POWER TRANSMISSION CORPORATION LIMITED (OPTCL)	
Technical Specification	TB-4-420-316-xxx Rev 00
Section-3: Project Details and General Specification	

with the relevant IEC"s or IS or equivalent standards. The specific details of testing and inspection are given in the appropriate section of this Specification.

The Bidder shall submit Type Test Reports for all equipment being supplied by him for the BHEL/OPTCL"s approval. The BHEL/OPTCL may also give instruction to carry out Type Tests, routine tests or acceptance tests. Type Test Charges shall be paid as per the rates indicated in the Price Schedules.

All materials used shall be subjected to such routine tests as are customary in the manufacture of the types of plant included in the Contract Works. These materials shall withstand satisfactorily all such tests.

All tests shall be carried out to the satisfaction of the BHEL/OPTCL, in his presence, at such reasonable times as he may require, unless agreed otherwise. Not less than three weeks' notice of all tests shall be given to the BHEL/OPTCL in order that he may be represented if he so desires. As many tests as possible shall be arranged together. Six copies of the Bidder"s test reports and test sheets shall be supplied to the BHEL/OPTCL for approval.

Measuring apparatus shall be approved by the OPTCL/BHEL (Divisional Engr) and if required shall be calibrated at the expense of the Bidder at an approved laboratory.

The Bidder shall be responsible for the proper testing of the work completed or plant or materials supplied by a sub-bidder to the same extent as if the work, plant or materials were completed or supplied by the Bidder himself.

All apparatus, instruments and connections required for the above tests shall be provided by the Bidder, but the BHEL/OPTCL may permit the use for the tests on site, any instruments and apparatus which may be provided permanently on site as part of the contract works conditional upon the Bidder accepting liability for any damage which may be sustained by such equipment during the test.

The bidder shall supply suitable test pieces of all materials as required by the BHEL/OPTCL. If required by the BHEL/OPTCL, test specimens shall be prepared for check testing and forwarded at the expense of the Bidder to an independent testing authority selected by the BHEL/OPTCL.

Any costs incurred by the Employer in connection with inspection and re-testing as a result of a failure of the subject under test, or damage during transport, or erection on site before take-over by the Employer, shall be to the account of the Bidder.

No inspection or lack of inspection or passing by the BHEL/OPTCL of work, plant or materials, whether carried out or supplied by the Bidder or sub-bidder, shall relieve the Bidder from his liability to complete the Contract Works in accordance with the Contract or exonerate him from any of his guarantees.

3.20.1 TYPE TEST REQUIREMENTS FOR EQUIPMENTS OTHER THAN GIS

- a) All equipment to be supplied shall be of type tested design. During detail engineering, the bidder shall submit for Owner's approval the reports of all the type tests as listed in this specification and carried out not earlier than ten years prior to the date of techno-commercial bid opening (03-March-2017). These reports should be for the test conducted on the equipment similar to those proposed to be supplied under this contract and the test(s) should have been either conducted at an independent laboratory or should have been witnessed by a Client.
- b) However if bidder is not able to submit report of the type test(s) conducted not earlier than ten years prior to the date of techno-commercial bid opening (**11-February-2022**), or in the case of type test report(s) are not found to be meeting the specification requirements, the bidder shall conduct all such

PROJECT: 2X500 MVA, 400/220 KV GIS S/S AT ERSAMA & ASSOCIATED 2 NOS 400 KV BAY EXTN AT DUBURI	
CUSTOMER: ODISHA POWER TRANSMISSION CORPORATION LIMITED (OPTCL)	
Technical Specification	TB-4-420-316-xxx Rev 00
Section-3: Project Details and General Specification	

- tests under this contract at no additional cost to the owner either at third party lab or in presence of client/ owners representative and submit the reports for approval.
- c) All acceptance and routine tests as per the specification and relevant standards shall be carried out. Charges for these shall be deemed to be included in the equipment price.

3.20 PACKAGING & TRANSPORTATION

The Bidder shall be responsible for the packing, loading and transport of the plant and equipment from the place of manufacture, whether this is at his own works or those of any Bidder, to Site, and for off-loading at site.

All apparatus and equipment shall be carefully packed for transport by air, sea, rail and road as necessary and in such a manner that it is protected against tropical climate conditions and transport in rough terrain and cross country road conditions. The method of packing shall provide complete protection to all apparatus and equipment during transport and storage at site in heavy rain. The method of packing shall provide adequate protection to main items of plant and those parts contained within and attached without, for transportation.

Precautions shall be taken to protect parts containing electrical insulation against the ingress of moisture. All bright parts liable to rust shall receive a coat of anti-rusting composition and shall be suitably protected. The machined face of all flanges shall be protected by means of a blank disc bolted to each face.

Where appropriate all parts shall be boxed in substantial crates or containers to facilitate handling in a safe and secure manner. Each crate or container shall be marked clearly on the outside of the case to show "TOP" and "BOTTOM" positions with appropriate signs, and where the mass is bearing and the correct position for slings. Each crate or container shall also be marked with the notation of the part or parts contained therein, contract number and port of destination. It shall be the Bidder's responsibility to dispose of all such packing.

Any damage due to defective or insufficient packing shall be made good by the Bidder at his own expense and within reasonable time when called upon by the BHEL/OPTCL to do so. Four (4) copies of complete packing lists showing the number, size, marks, mass and contents of each package shall be delivered to the BHEL/OPTCL immediately the material is despatched.

The Bidder shall inform himself fully as to all relevant transport facilities and requirements and loading gauges and ensure that the equipment as packed for transport shall conform to these limitations. The Bidder shall also be responsible for verifying the access facilities specified.

The Bidder shall be responsible for all costs of repair or replacement of the equipment, including those incurred by the Employer, arising from damage during transport, off-loading or erection on site, until take-over by the Employer.

The Bidder shall be responsible for the transportation of all loads associated with the contract works and shall take all reasonable steps to prevent any highways or bridges from being damaged by his traffic and shall select routes, choose and use vehicles and restrict and distribute loads so that the risk of damage shall be avoided. The Bidder shall immediately report to the BHEL/OPTCL any claims made against the Bidder arising out of alleged damage to a highway or bridge.

3.21 ENCLOSURES:

1. ANNEXURE – A: SPECIFICATION FOR ELECTRICAL COMPONENTS

NOTE:

Contractor is to be replaced with subcontractor/vendor.

1. MOTORS

1.1 General

All motors shall comply with IEC 34 / IS 335 and dimensions with IEC 72, however they shall be capable of operating continuously under actual service conditions without exceeding the specified temperature rises, determined by resistance, at any frequency between 48 and 51.5 Hertz together with any voltage between ± 10 per cent of the nominal value.

All motors shall be totally enclosed, and if situated in the open they shall be weatherproof and suitable for outdoor working. They shall be provided with a suitable means of drainage to prevent accumulation of water due to condensation and with suitable means of breathing.

Motors operating in an ambient temperature not exceeding 40°C shall have insulation to at least Class B and preferably Class F standards. The temperature rise shall be restricted to that associated with Class B insulation. Where the motor may be appreciably affected by conducted heat the class of insulation shall be to approval.

All motors shall be suitable for direct starting at full voltage.

Motors shall have sealed ball or roller bearings.

The three line connections of AC motors shall be brought out to a terminal box. The terminal arrangement shall be suitable for the reception of aluminium cable. Terminal markings shall be made in a clear and permanent manner and shall comply with IEC 34. A permanently attached diagram or instruction sheet shall be provided giving the connections for the required direction of rotation. All terminal boxes shall be of the totally enclosed type designed to exclude the entry of dust and moisture and sealed from the internal air circuit of the motor. All joints shall be flanged with gaskets of neoprene or other approved material. Natural rubber insulation shall not be used.

Motors rated above 1 kW shall be three phase motors. Where single phase motors are employed the motors shall be grouped so as to form an approximately balanced three phase load.

1.2 Motor control gear

Control gear shall comply with the requirements of IEC 292, the control gear being rated according to the duty imposed by the particular application.

Motor contactors shall comply with IEC 158 class of intermittent duty 0-3 with type 52 enclosure protection. Apparatus shall be capable of switching the stalled current, and shall have a continuous current rating of at least 50 per cent greater than the full load current of the motors they control.

The operating currents of overload trips fitted to motor contactors shall be substantially independent of ambient temperature conditions, including the effect of direct sunlight on the enclosure in which the contactors are installed.

Where small motors are connected in groups, the group protection shall be arranged so that it will operate satisfactorily in the event of a fault occurring on a single motor. The control and protection equipment shall be accommodated in the control cabinet or marshalling kiosk.

Each motor or group of motors shall be provided with control gear for starting and stopping by hand and automatically. Overload and single-phasing protection shall be provided.

2.0 CABLE BOXES

Cable boxes shall be suitable for cables entering from above or below as may be required. They shall be weatherproof, rodent and insect-proof and be complete with all gaskets, compression glands, wiping glands and all associated fittings as may be required to make-off the cables.

Gland plates shall be insulated from the cable boxes and, in the case of single core cables, shall be of non-magnetic or insulating material. If metallic gland plates are used, single core cable glands shall be insulated from the gland plate. Gland plate insulation shall be capable of withstanding a dry high voltage test of 2000volts ac for one minute.

Where cable boxes are provided for three core cables, the sockets on the outer phases shall be inclined towards the centre to minimise opening of the cable cores. Cable sockets shall be supplied under this Contract.

Cable boxes for voltages up to and including 11kV shall be suitable for PVC or XLPE insulated steel wire-armoured PVC served cables. The boxes shall be air insulated and designed to accommodate all the fittings required by the cable manufacturer. Front covers and gland plates shall be removable and a 12mm diameter breathing hole covered with a wire gauze shall be provided.

Cable boxes shall be capable of withstanding on site the cable high voltage test level in accordance with IEC 502.

The drilling of gland plates, supply and fitting of compression glands and connecting up of power cables not included in the Contract scope of work shall be carried out under a separate contract.

Connection of the power cables included in the Contract scope of works shall be carried out under this Contract.

3.0 TERMINAL BOARDS AND TERMINAL BLOCKS

Terminal boards shall be of good quality non-flammable insulating material with a comparative tracking index (CTI) of not less than 500 to IEC112.

Terminal boards shall be spaced not less than 150 mm apart. For relay panels, they shall be mounted at the sides of the cubicle, and set obliquely towards the rear doors to give easy access to termination and to enable ferrule numbers to be read without difficulty.

Studs of stud type terminal boards shall be locked in the base to prevent turning and all connections shall be made on the front of the terminal board using lock nuts or lock washers. Where crimped type termination are provided at least two sets of crimping tools for each size of crimp must be supplied for each installation.

Terminals shall be of the insertion clamp type incorporating captive pressure screws which do not bear directly on the wire but on a serrated clamping plate. The pressure screws shall have an inherent locking feature.

Where connections are to be made between multi-core cables and telephone type multi-pair cables, the terminal blocks shall be of the insulation displacement type and shall have a withdrawable insulated link in order to facilitate isolation (or busy out in the case of the apparatus associated with the telephone system) of the individual circuits. These terminals shall also be provided with facilities for the insertion of test probes on both sides of the link.

All terminations shall be numbered for identification and grouped according to function. Engraved white on black labels shall be provided on the terminal blocks.

Terminals for connections which exceed 110 Volts shall be separated from those of other circuits and shall be fitted with insulating screens and "DANGER" notices.

The use of terminal blocks as junction points for wires which are not required in the associated cubicle shall be avoided wherever practicable.

All termination racks shall have a minimum of 20 per cent spare terminals blocks. At least 20% spare terminals shall be provided on each panel and these spare terminals shall be uniformly distributed on all terminal blocks.

All internal wiring to be connected to external equipments shall terminate on terminal blocks, preferably vertically mounted on the side of each panel. Terminal blocks shall be 650 V grade and have

10A continuous rating. Terminal blocks shall be moulded in one piece, complete with insulated barriers, stud type terminals, washers, nuts and lock nuts. Terminal blocks shall include a white fibre marking strip with clear plastic, slip-on/clip-on terminal covers. Markings on the terminal strips shall correspond to terminal numbers on the wiring diagrams.

Terminal blocks for current transformer and voltage transformer secondary leads shall be provided with test links and isolating facilities. Current transformer secondary leads shall be provided with short circuiting and earthing facilities.

All terminal blocks shall be suitable for terminating on each side, two by 2.5 mm² standard copper conductors.

Wherever duplication of a terminal block is necessary it shall be achieved by solid bonding links.

Unless otherwise specified, terminal blocks shall be suitable for connecting the following conductors on each side :

- All CT and VT circuits : Minimum of two 2.5 mm² copper stranded.
- AC/DC power supply circuits : One 16 mm² aluminium.
- All other circuits : Minimum of one of 2.5 mm² copper stranded

There shall be a minimum clearance of 250 mm between the first row of terminal blocks and the associated cable gland plate or panel side wall, as per the terminal block mounting arrangement adopted. Also the clearance between the edges of two rows of terminal blocks shall be minimum of 150 mm.

Arrangement of the terminal block assemblies and the wiring channel within the enclosure shall be such that a row of terminal blocks is run in parallel and close proximity along each side of the wiring duct to provide for convenient attachment of internal panel wiring. The side of the terminal blocks opposite the wiring duct shall be reserved for external cable connections. All adjacent terminal blocks shall also share this field wiring corridor. All wiring shall be provided with adequate support inside the panels to hold it firmly and to enable free and flexible termination without causing strain on terminals.

All necessary cable terminating accessories such as gland plates, supporting clamps and brackets, wiring troughs and gutters etc. including glands and lugs for cable shall be in bidders scope of supply.

4.0 FUSES AND LINKS

Carriers and bases for fuses and links shall be in accordance with IEC 269 and colour coded to permit identification of the circuit rating.

The fuses and links mounted in cubicles for tripping circuits and protective gear test links shall be mounted on the front of the panel. Other links and fuses shall be accommodated within the cubicle or above the cubicle doors. Fuses and links shall be grouped and spaced according to their function in order to facilitate identification.

All incoming circuits in which the voltage exceeds 125V shall be fed through insulated fuses and/or links, the supplies being connected to the bottom terminal. The contacts of the fixed portion of the fuse or link shall be shrouded so that accidental contact with live metal cannot be made when the moving portion is withdrawn.

Main supply fuse links shall be of the high rupturing capacity cartridge type.

Where fuse carriers are mounted vertically the incoming (supply) side shall be the bottom terminal.

Where either fuses or circuit breakers are used it should be ensured that proper discrimination between main and sub-circuits is maintained.

5.0 COMMUNICATIONS CABLES

All cables and wiring shall have copper conductors and PVC insulation and shall comply with IEC 227. Telephone type cables shall comply with IEC 96 and IEC 189.

Cabling and wiring installations shall be arranged to minimise the risk of fire and damage which may be caused in the event of fire.

For telephone type cables conductor wires with a cross sectional area of less than 0.2 mm² shall not be used. Where twin or quad make up is required in any cable the cores shall be uniformly twisted and the lays arranged such that crosstalk is reduced to a minimum.

No conductor smaller than 32/0.2mm (1mm²), or having less than three strands shall be used for interconnecting cabling except in the case of telephone cables. All cables shall have insulation which will withstand the highest temperature to be experienced in service.

Each conductor of a multi-core cable shall be readily identified by a numbered marker tape or, in the case of telephone type cables, colour coded insulation.

The Bidder shall submit full details of all loading on cables and in the case of interposing current transformer connections, the loop resistance of each circuit.

Apparatus cubicles, cabinets, racks and panels shall be provided with gland plates and all necessary equipment for the termination of cables. The Contract Works shall include for the checking, termination and ferruling of the cable cores and their lacing into cable forms and connection to the equipment terminal boards or tag blocks using claw washers. Crimping ferrules shall be used for each conductor.

6.0 MARSHALLING KIOSKS AND CONTROL CABINETS

The bidder shall provide within every bay of the switch yard a bay marshalling kiosk to which all incoming and outgoing connections to and from the associated bay equipment will be run. The terminal blocks within the kiosks shall be grouped together by function and shall be properly labelled and segregated. Transformer and circuit breaker control/marshalling kiosks will be provided under a separate contract, but it shall be the contractor's responsibility to cable up to the control/marshalling kiosks as provided by the transformer and circuit breaker suppliers. The Contractor shall provide a separate stand alone kiosk for busbar protection CT marshalling and the kiosk shall house the CT shorting and switching relays required for the correct function of the busbar protection scheme.

All outdoor cabinets and kiosks shall be protected in accordance with Class IP55 of IEC 947-1 and shall be insect and rodent proof. The minimum sheet steel thickness for all cubicles, kiosks and panels shall be not less than 2 mm cold rolled or 2.5 mm hot rolled sheet steel. The top of the outdoor boxes/kiosks shall be provided with Aluminium alloy sheets having 2 mm thick with proper sloping for easy discharge of water.

Anti-condensation heaters, 240V AC single phase, shall be provided and shall be controlled by a watertight switch mounted externally. Ventilation louvres shall be provided, suitably lined internally with a mesh screen, and divisions between compartments shall be perforated.

Control cabinets shall be illuminated with a switch operated and fused 240V CFL tube. Control cabinets shall be provided with a switch operated single phase 240V 15A power socket.

All cables shall enter cabinets and kiosks at the base.

Each compartment of all kiosks and cabinets shall be provided with access doors at the front and rear. Doors and access covers shall not be secured by nuts and bolts but shall be fastened with integral handles with provision for locking with a padlock.

Doors for kiosks shall be of the lift off and hinged type and shall be provided with glazed windows of adequate size to facilitate reading of indicators from outside the kiosk. Facilities shall be provided to permit removal of the temperature indicators without the need to pass the capillary tubing and bulb through the various compartments.

Doors and covers under 15kg mass may be of the slide on pattern, but above this mass hinged doors shall be used. Door shall be provided with padlocking facilities.

When three phase connections rated at 380V and above are taken through cabinets or kiosks, the terminal blocks shall be adequately screened, insulated and suitably marked with the phase colour; "DANGER" notices shall be affixed to the terminal blocks and a DANGER notice stating the voltage shall be fixed on the inside and outside of the kiosk or cabinet. Exterior DANGER notices shall be stove enamelled and shall be written in English and Oriya and shall be of an approved class/grade.

A durable copy of the circuit wiring diagram shall be affixed to the back of the kiosk door and labels shall be provided inside each kiosk or box to describe the functions of the various items of equipment.

When the marshalling kiosks are positioned in side the switchyard , flood water shall not ingress in to the marshalling kisok. The contractor/bidder may achieve the same either positioning the marshalling kiosk appropriately or providing adequate water proof arrangement.

CT, CVT & IVT outdoor kiosks shall be of Aluminium alloy sheets having 3mm thickness. It shall have proper slop canopy for easy drainage of water.

7.0 AUXILIARY SWITCHES

With each disconnecter, contactor and earthing device, there shall be supplied all necessary auxiliary switches and mechanisms for indication, protection, control, interlocking, supervisory and other services as specified. Not less than four spare auxiliary switches of each type shall be provided.

All auxiliary switches shall be wired up to a suitable terminal board on the fixed portion of the switchgear whether they are in use or not in the first instance, and shall be arranged in the same sequence on all similar items of equipment. Switches shall be provided to interrupt the supply of current to the tripping mechanism of the circuit breakers and latched contactors. All such switches and mechanisms shall be mounted in accessible positions clear of the operating mechanism, and shall be adequately protected.

The contacts of all auxiliary switches shall be strong and be capable of adjustment in relation to the movement of the circuit breaker or other item of equipment. Auxiliary switches and auxiliary circuits shall be capable of carrying a continuous current of 10 Amps.

8.0 MINIATURE OR MOULDED CASE CIRCUIT BREAKERS

Miniature or moulded case circuit breakers (MCB's or MCCB's) shall be designed and tested in accordance with IEC 157 and supplementary requirements of this specification. They shall be suitable for use over the full range of expected voltage variation as specified in the Schedules.

MCB's and MCCB's shall be suitably rated for both the continuous and short circuit loading of the circuits they are protecting under all service and atmospheric conditions stated in the specification. The bidder shall ensure that correct discrimination is maintained between main and sub-circuits.

For three phase circuits, the miniature circuit breakers shall be of the three pole type; for single phase circuits they shall be of the single pole type and for dc circuits they shall be of the double pole type.

Where miniature circuit breakers are used in circuits containing inductive loads, e.g. operating coils, it is essential that they are suitable for satisfactory operation in the circuit in which they are used, i.e. account is taken of the circuit time constant.

All miniature circuit breakers shall be provided with an auxiliary contact for remote indication of circuit breaker operation.

Means shall be provided to prevent the miniature circuit breakers being inadvertently switched to the „OFF“ position.

Miniature circuit breakers shall be mounted in such a manner so as to give easily visible indication of breaker position and shall be grouped and spaced according to their function in order to facilitate identification and easy replacement.

9.0 SPACE HEATERS

Heaters shall be suitably designed to prevent any contact between the heater wire and the air. They shall consist of coiled resistance wire centred in a metal sheath and completely encased in a highly compacted powder of magnesium oxide or other material having equal heat conducting and electrical insulation properties, or they shall consist of resistance wire wound on a ceramic and completely covered with a ceramic material to prevent any contact between the wire and the air.

Alternatively, they may consist of a resistance wire mounted into a tubular ceramic body built into an envelop of stainless steel or the resistance wire wound on a tubular ceramic body and embedded in vitreous glaze. The surface temperature of the heaters shall be restricted to a value which will not shorten the life of the heater sheaths or that of insulated wire or other component in the compartments.

10.0 LVAC CABLES (NOT APPLICABLE)

10.1 General

LVAC power cables shall have aluminium conductors with XLPE insulation, galvanised steel wire armour and PVC oversheath and shall comply with the requirements of IEC 227, 228 and 502 as applicable. Cables shall be sized to carry the highest anticipated load under the worst case ambient conditions. Where a three, three and a half or four core power cable is provided, the cores shall be coloured to distinguish the relevant phases.

All sheaths shall be free from defects and impervious to water.

10.2 1.1kV grade power and control cables

10.2.1 Codes and Standards

The design, manufacture, testing and performance of cables covered under this specification shall comply with latest edition of the standards including amendments as indicated in the relevant schedules attached to this specification.

10.2.2 Technical requirements

The cables shall be suitable for laying in racks, ducts, trenches, conduits and underground buried installation with uncontrolled backfill and chances of flooding by water.

They shall be designed to withstand all mechanical, electrical and thermal stresses under steady state and transient operating conditions. The XLPE insulated LV power cables shall withstand without damage a three phase fault current of at least 45 kA for a minimum of 0.12 seconds, with an initial peak of 105 kA in one of the phases. The armour for XLPE insulated power cables shall be capable of carrying 45 kA for at least 0.12 seconds without exceeding the maximum allowable temperature of PVC outer sheath.

Progressive sequential marking of the length of cable in metres at every one metre shall be provided on the outer sheath of all cables.

Strip wire armouring following method (a) of the relevant IS shall not be accepted for any of the cables. For control cables round wire armouring only shall be used.

Cables shall have outer sheath of a material with an oxygen index of not less than 29 and a temperature index of not less than 250°C.

All the cables shall pass fire resistance test as per IS 1554 (Part-I)

The normal current rating of all PVC insulated cables shall be as per IS 3961.

Repaired cables shall not be accepted.

10.3 LV XLPE power cables

XLPE insulated cables shall conform to IS 7098 (Part-I) and its amendments read along with this Specification. The conductor shall be stranded aluminium circular/sector shaped and compacted. In multi-core cables, the core shall be identified by red, yellow, blue and black coloured strips or colouring of insulation. A distinct inner sheath shall be provided in all multi-core cables even if they are unarmoured. For armoured or unarmoured cables, the inner sheath shall be of extruded PVC to type ST-2 of IS 5831. When armouring is specified for single core cables, the same shall consist of aluminium wires/strips.

10.4 LV XLPE power cables

PVC (70C) insulated 1100V grade power cables shall conform to IS 1554 (Part-I) and its amendments, read along with this Specification and shall be suitable for a steady conductor temperature of 70°C. The conductor shall be stranded aluminium. Insulation shall be extruded PVC to type-A of IS 5831. A distinct inner sheath shall be provided in all multi-core cables. For multi-core armoured cables, the inner sheath shall be of extruded PVC. The outer sheath shall be extruded PVC to Type ST-1 of IS 5831 for all cables.

10.5 LV PVC control cables

The 1100V grade control cables shall conform to IS 1554 (Part-1) and its amendments, read along with this specification. The conductor shall be stranded copper. The insulation shall be extruded PVC to type A of IS 5831. A distinct inner sheath shall be provided in all cables whether armoured or not. The oversheath shall be extruded PVC to type ST-1 of IS 5831 and shall be grey in colour except where specifically advised by the Project Manager to be black.

Cores shall be identified as per IS 1554 (Part-1) for cables up to five cores and for cables with more than five cores the identification of cores shall additionally be done by printing legible alphabets on all cores. The alphabets shall be white and shall be printed at approximately 100 mm intervals along the cable length. Cables without such core identifications will not be accepted.

10.6 Cable drums

Cables shall be supplied non-returnable wooden or steel drums of heavy construction. Wooden drums shall be properly seasoned sound and free from defects. Wood preservative shall be applied to the entire drum.

Standard lengths for each size of power and control cables shall be 500/1000 meters. The cable length per drum shall be subject to a tolerance of plus or minus 5% of the standard drum length. The Project Manager shall have the option of rejecting cable drums with shorter lengths. However, the total quantity of cables after taking into consideration of all cable drums for each size shall be within the tolerance of $\pm 2\%$.

A layer of water proof paper shall be applied to the surface of the drums and over the outer most cable layer.

10.7 Tests

All cables shall conform to all type, routine and acceptance tests listed in the relevant IS.

The temperature index tests shall be carried out as per ASTM-D-2863.

All cables shall meet the fire-resistance test as per IS 1554 (Part-I)

10.8 Cable sizes

Following standard sizes of cables shall be considered by Bidder for various power distribution and protection, control and metering purposes in the system:

- XLPE power cables: 1c 630 mm², 1c 300 mm², 3 1/2c 300 mm². (armoured)
- LV XLPE power cables: (armoured) 1c 150 mm², 3 1/2c 70 mm², 3 1/2c 35 mm², 4c 16 mm², 4c 6 mm², 2c 6 mm².
- PVC control cables: 2c 2.5 mm², 3c 2.5 mm², 5c 2.5 mm², 7c 2.5 mm², 10c 2.5 mm², 14c 2.5 mm², 19c 2.5 mm², 27c 2.5 mm²

11.0 BUSHINGS

All bushings shall comply with the requirements of IEC 137 and the associated barrel porcelains shall comply with IEC 233 together with the requirements of this Specification. Provision shall be made for the fitting of arcing horns.

Transformer bushings rated at 66 kV and above shall be either of the oil impregnated paper or resin impregnated type. When filled with transformer oil there shall be no connection with the oil in the transformer and an oil gauge shall be provided. The visible oil levels in the gauge shall correspond to the range of average oil temperatures, from the minimum ambient stated in the Schedules to plus 70C. The oil level at 15C shall be marked. Connections from the main windings to bushings shall be flexible and shall be such that undue mechanical stresses are not imposed on them during assembly on site.

Terminal clamps shall be supplied with each bushing for flexible or rigid busbars as may be required. The material of the clamps shall be as stated in the Schedules.

12.0 BUSHINGS, HOLLOW COLUMN INSULATORS, SUPPORT INSULATORS

Bushings shall be manufactured and tested in accordance with IS 2099 and IEC 137 while hollow column insulators shall be manufactured and tested in accordance with IEC 233/IS 5621. The support insulators shall be manufactured and tested as per IS 2544/IEC 168 and IS 2099/IEC 273. The insulators shall also conform to IEC 815 as applicable.

The bidder may also offer composite silicon insulators conforming to IEC 36.

Support insulators, bushings and hollow column insulators shall be manufactured from high quality porcelain. Porcelain used shall be homogeneous, free from laminations, cavities and other flaws or imperfections that might affect the mechanical or dielectric quality and shall be thoroughly vitrified tough and impervious to moisture.

Glazing of the porcelain shall be uniform brown in colour, free from blisters, burrs and other similar defects.

Support insulators, bushings and hollow column insulators shall be designed to have ample insulation, mechanical strength and rigidity for the conditions under which they will be used.

When operating at normal rated voltage there shall be no electric discharge between the conductors and bushing which would cause corrosion or injury to conductors, insulators or supports by the formation of substances produced by chemical action. No radio interference shall be caused by the insulators or bushings when operating at the normal rated voltage.

Bushing porcelain shall be robust and capable of withstanding the internal pressures likely to occur in service. The design and location of clamps and the shape and the strength of the porcelain flange securing the bushing to the tank shall be such that there is no risk of fracture. All portions of the assembled porcelain enclosures and supports other than gaskets, which may in any way be exposed to the atmosphere shall be composed of completely non hygroscopic material such as metal or glazed porcelain.

All iron parts shall be hot dip galvanised and all joints shall be air tight. Surface of joints shall be trued up, porcelain parts by grinding and metal parts by machining. Insulator and bushing design shall be such as to ensure a uniform compressive pressure on the joints.

12.1 Tests

In accordance with the requirements stipulated above bushing, hollow column insulators and support insulators shall conform to type tests and shall be subjected to routine tests in accordance with IS 2099 and IS 2544.

All routine tests shall be conducted on hollow column insulators as per IEC 233. In addition the following tests shall also be conducted

1. Ultrasonic test as a routine test.
2. Pressure test as a routine test.
3. Bending load test in four directions at 50% specified bending load, as a routine test.
4. Bending load test in four directions at 100% specified bending load, as a sample test on each lot.
5. Burst pressure test as a sample test on each lot.
6. Hollow porcelain insulators should be in one integral piece in green and fired stage. No jointed porcelain will be acceptable.

12.2 Technical parameters of bushings, hollow column insulators and support insulators:

Parameter	420kV	245kV	145kV	36kV
Rated voltage kV	420	245	145	36
Impulse withstand (wet and dry) kVp	±1425	±1050	±650	±170
Switching surge withstand (wet and dry) kVp	±1050			
Power frequency withstand (wet and dry) kVrms	630	460	275	70
Total creepage distance mm	10500	6125	3625	900

Pollution level shall be Class III Heavy as per IEC 71, and as specified in Schedules for all classes of equipment.

Insulators shall also meet the requirements of IEC 815 for 420kV, 245kV and 145kV systems as applicable having alternate long and short sheds.

13.0 CIRCUIT BREAKERS

13.1 General

Circuit breakers shall be of three pole air break design, horizontal draw out type in accordance with IEC 947-2. In particular, evidence shall be provided of the performance when switching currents in the critical current range. They shall be capable of the ratings specified in the Schedules, when mounted in the switchboard.

Circuit breakers shall be fitted with trip-free, spring-operated mechanisms of the independent manually operated type and be provided with making and over current release facilities. A push-button shall be provided to trip the breaker electrically.

The breaker shall be provided with '**OPEN**', '**CLOSE**', '**SERVICE**', '**TEST**' and '**SPRING CHARGED**' position indicators and shall be provided with the necessary number of auxiliary contacts for interlocking, indication and tripping purposes plus two spare.

Each incoming circuit shall be provided with thermal overload relays and short circuit protection relays; they shall also be provided with an undervoltage relay to trip breaker in the event of a supply failure.

There shall be 'SERVICE', 'TEST' and fully withdrawn positions for the breakers. It shall be possible to close the door in „TEST' position.

Movement of a circuit breaker between „SERVICE' and „TEST' positions shall not be possible unless it is in „OPEN' position. Attempted withdrawal of a closed circuit breaker shall not trip the circuit breaker.

Closing of a circuit breaker shall not be possible unless it is in „SERVICE', „TEST' or fully withdrawn positions.

A breaker of particular rating shall be prevented from insertion in a cubicle of a different rating.

Circuit breakers shall be provided with electrical anti-pumping and trip free feature.

Means shall be provided to slowly close the circuit breaker in withdrawn position if required for inspection and setting of contacts. In service position slow closing shall not be possible.

Circuit breakers shall be provided with the following mechanism as specified in the Bill of Material.

13.2 Power operated mechanism

Power operated mechanism shall be provided with a universal motor suitable for operation 220V DC control supply with voltage variation from 90% to 110% rated voltage. Motor insulation shall be class 'E' or better.

The motor shall be such that it requires not more than 30 seconds for fully charging the closing spring.

Once the closing springs are discharged, after the one closing operation of circuit breaker, it shall automatically initiate, recharging of the spring.

The mechanism shall be such that as long as power is available to the motor, a continuous sequence of closing and opening operations shall be possible. After failure of power supply at least one open-close-open operation shall be possible.

Provision shall be made for emergency manual charging and as soon as this manual charging handle is coupled, the motor shall automatically be mechanically decoupled.

All circuit breakers shall be provided with closing and tripping coils. The closing coils shall operate correctly at all values of voltage between 85% to 110% at rated control voltage. Tripping coils shall operate satisfactorily under all values of supply voltage between 70% to 110% of rated control voltage.

Provision for mechanical closing of the breaker only in 'TEST' and withdrawn positions shall be made.

14.0 RELAYS

All relays and timers in protective circuits shall be flush mounted on panel front with connections from the inside. They shall have transparent dust tight covers removable from the front. All protective relays shall have a drawout construction for easy replacement from the front. They shall either have built-in test facilities, or shall be provided with necessary test blocks and test switches located immediately below each relay. Auxiliary relays and timers may be furnished in non-drawout cases.

All AC relays shall be suitable for operation at 50 Hz with 110 volts VT secondary and 1A or 5A CT secondary.

All protective relays and timers shall have at least two potential free output contacts. Relays shall have contacts as required for protection schemes. Contacts of relays and timers shall be silver faced and shall have a spring action. Adequate numbers of terminals shall be available on the relay cases for applicable relaying schemes.

All protective relays, auxiliary relays and timers shall be provided with hand reset operation indicators (flags) for analysing the cause of operation.

All relays shall withstand a test voltage of 2kV (rms) for one minute.

Motor starters shall be provided with three element, ambient temperature compensated, time lagged, hand reset type terminal overload relays with adjustable settings. The setting ranges shall be properly selected to suit the motor ratings. These relays shall have a separate black coloured hand reset push button mounted on compartment door and shall have at least one changeover contact.

All fuse protected, contactor controlled motors shall have single phasing protection, either as a distinct feature in the overload relays (by differential movement of bi-metallic strips), or as a separate device. The single phasing protection shall operate with 80% of the set current flowing in two of the phases.

15.0 CONTACTORS

Motor starter contactors shall be of air break, electromagnetic type rated for uninterrupted duty as per IS 2959.

Contactors shall be double break, non-gravity type and their main contacts shall be silver faced.

Direct line starter contactors shall be of utilisation category AC2. These contactors shall be as per IS 1822.

Each contactor shall be provided with two normally open (NO) and two normally close (NC) auxiliary contacts.

Operating coils of contactors shall be of 240V AC unless otherwise specified elsewhere. The Contactors shall operate satisfactorily between 85% to 110% of the rated voltage. Contactors shall drop out at 70% of the rated voltage.

16.0 INSTRUMENT TRANSFORMERS

All current and voltage transformers shall be completely encapsulated cast resin insulated type suitable for continuous operation at the temperature prevailing inside the switchgear enclosure, when the switchboard is operating at its rated condition and the outside ambient temperature is 50°C.

All instrument transformers shall be able to withstand the thermal and mechanical stresses resulting from the maximum short circuit and momentary current ratings of the associated switchgear.

All instrument transformer shall have clear indelible polarity markings. All secondary terminals shall be wired to a separate terminal on an accessible terminal block where star-point formation and earthing shall be done.

Current transformers may be multi or single core type. All voltage transformers shall be single phase type. Busbar VT's shall be housed in a separate compartment.

All VT's shall have readily accessible HRC current limiting fuses on both primary and secondary sides.

17.0 INDICATING INSTRUMENTS

All indicating and integrating meters shall be flush mounted on panel front. The instruments shall be of at least 96 mm square size with 90 degree scales, and shall have an accuracy class of 2.5 or better. The covers and cases of instruments and meters shall provide a dust and vermin proof construction.

All instruments shall be compensated for temperature errors and factory calibrated to directly read the primary quantities. Means shall be provided for zero adjustment without removing or dismantling the instruments.

All instruments shall have white dials with black numerals and lettering. Black knife edge pointer with parallax free dials will be preferred.

Ammeters provided on motor feeders shall have a compressed scale at the upper current region to cover the starting current.

Watt-hour meters shall be of three phase, three element type. Maximum demand indicators need not be provided.

18.0 CONTROL AND SELECTOR SWITCHES

Control and instrument switches shall be rotary operated type with escutcheon plates clearly marked to show the function and positions. Switches shall be suitable for flush mounting with only switch front plate and operating handle projecting from the panel front. Switches shall be of sturdy construction suitable for mounting on panel front. Switches with shrouding of live parts and sealing of contacts against dust ingress shall be preferred. Handles of different shapes along with suitable inscriptions on switches shall be provided as an aid to switch identification. The selection of operating handles for the different types of switches shall be as follows :

Switch Type	Application	Specification
Switchgear control switches	For closing and opening of breakers and isolators.	Pistol grip, black, three position type.
Synchronising switches	For synchronising check bypass facilities	Oval, black, keyed (common removable handle, or with locking facility and common key).
Selector switches	Auto, manual, local, remote and test facilities	Oval or knob, black
Instrument switches	Phase or meter selection	Round, knurled, black
Protection transfer switch	Transfer of protection.	Pistol grip, lockable and black.

TABLE 18.1 Switch operating handles

The control switches of breakers and isolators shall be of spring return to neutral type. The control springs shall be strong and robust enough to prevent inadvertent operation due to light touch. The spring return type switch shall have spring return from close and trip positions to “after close” and “after trip” positions respectively. They shall have at least two (2) contacts closing in close positions, and two (2) contacts closing in Trip positions unless specified otherwise.

Circuit breaker selector switches for breaker controlled motors shall have three stay put positions marked „**AUTO**’, „**MANUAL**’ and „**TEST**’ respectively. They shall have two contacts each of three positions and shall have black, pistol grip handles.

Instrument selection switches shall be of maintained contact stayput type. Ammeter selection switches shall have make-before-break type contacts so as to prevent open circuiting of CT secondaries when changing the position of the switch. Voltmeter transfer switches for AC shall be suitable for reading all line-to-line and line-to-neutral voltages for non effectively earthed systems, and for reading all line to line voltages for effectively earthed systems. Ammeter and voltmeter selector switches shall have four stayput positions with an adequate number of contacts for three phase four wire systems. These shall have black oval handles

Synchronising switches shall be of maintained contact stayput type having a common removable handle for a group of switches. The handle shall be removable only in the „**OFF**’ position and it shall be co-ordinated to fit in to all the synchronising switches. These switches shall be arranged to connect the synchronising equipment when turned to the „**ON**” position. One contact of each switch shall be connected in the closing circuit of the respective breaker so that the breaker cannot be closed until the switch is turned to the „**ON**” position.

Lockable type switches which can be locked in particular positions shall be provided when specified. The key locks shall be fitted on the operating handles.

The contacts of all switches shall preferably open and close with snap action to minimise arcing. Contacts of switches shall be spring assisted and contact faces shall be with rivets of pure silver or silver alloy. Springs shall not be used as current carrying parts.

The contact combination and their operation shall be such as to give completeness to the interlocking and function of the scheme. The contact rating of the switches shall be as follows :

Description	Contact rating in Amps		
	220V DC	50V DC	240V AC
Make and carry continuously	10A	10A	10A
Make and carry Make and carry for 0.5 sec.	30A	30A	30A
Break			
Resistive load	3A	20A	7A
Inductive Load with L/R=40ms	0.2A	—	—

TABLE 18.2 Contact ratings of switches

19.0 AIR BREAK SWITCHES

Air breaker switches shall be of the heavy duty, single throw group operated, load break, fault make type complying with IS 4064.

The Bidder shall ensure that all switches are adequately rated so as to be fully protected by the associated fuses during all abnormal operating conditions such as overload, locked motor, short circuit etc.

Switch operating handles shall be provided with padlocking facilities to lock them in 'OFF' position.

Interlocks shall be provided such that it is possible to open the cubicle door only when the switch is in 'OFF' position and to close the switch only when the door is closed. However suitable means shall be provided to intentionally defeat the interlocks explained above.

Switches and fuses for AC/DC control supply and heater supply wherever required shall be mounted inside and cubicles.

20.0 PUSH BUTTONS

Push-buttons shall be of spring return, push to actuate type. Their contacts shall be rated to make, continuously carry and break 10A at 240V and 0.5A (inductive) at 220V DC.

All push-buttons shall have one normally open and one normally closed contact, unless specified otherwise. The contact faces shall be of silver or silver alloy.

All push-buttons shall be provided with integral escutcheon plates marked with the appropriate function.

The colour of the button shall be as follows :

- GREEN** : For motor **START**, breaker **CLOSE**, valve /damper **OPEN**
- RED** : For motor **TRIP**, breaker **OPEN**, valve /damper **CLOSE**
- BLACK** : For overload reset, all annunciator and miscellaneous functions.

All push-buttons on panels shall be located in such a way that red push buttons shall always be to the left of green push buttons.

21.0 INDICATING LAMPS

Indicating lamps shall be of the panel mounting filament type and low watt consumption. Lamps shall be provided with series resistors, preferably built-in the lamps assembly. The lamps shall have

escutcheon plates marked with its function, wherever necessary. Lamps shall have translucent lamp covers of colours appropriate to the application as indicated in Table 21.1

Colour	Indication
RED	For motor ON , breaker/isolator CLOSED , valve/damper OPEN
GREEN	For motor OFF , breaker /isolator OPEN , valve/damper CLOSE
WHITE	For motor Auto-Trip
BLUE	For all healthy conditions (e.g. control supply) and also for ' SPRING CHARGED '
AMBER	For all alarm conditions (e.g. overload) Also for ' SERVICE ' and ' TEST ' positions indicators.

TABLE 21.1 Indicating lamp colours

Indication lamps should be located just above the associated push buttons/control switches. Red lamps shall invariably be located to the right of green lamps. In case a white lamp is also provided, it shall be placed between the red and green lamps along with the centre line of control switch/push button pair. Blue and amber lamps should normally be located above the red and green lamps.

When associated with push-buttons, red lamps shall be directly above the green push button, and green lamps shall be directly above the red push-button.

The wattage and resistance of the lamps shall be as follows:

- 220/250V 5 - 10W 4000 - 8000 ohms
- 110V 5 - 10W 1000 - 2000 ohms

Neon indicating lamps or LED's shall be provided when specified. The wattage of the neon lamp shall be 0.25 to 0.5W.

Bulbs and lenses shall be interchangeable and easily replaceable from the front of the panel. Tools, if required for replacing the bulbs and lenses shall also be included in the scope of supply.

All indicating lamps shall be suitable for continuous operation at 90 to 110% of their rated voltage.

22.0 FUSES

All fuses shall be of HRC cartridge fuse link type. Screw type fuses shall not be accepted. Fuses for AC circuits shall be of Class 2 type, 20kA (RMS) breaking current at 415V AC, and for DC circuits Class 1 type 4kA breaking current.

Fuses shall have visible operation indicators.

Fuses shall be mounted on fuse carriers, which are mounted on fuse bases. Wherever it is not possible to mount fuses on carriers, they shall be directly mounted on plug in type bases. In such cases one set of insulated fuse pulling handles shall be supplied with each switchgear.

Fuse ratings shall be chosen by the bidder depending upon the circuit requirements and these shall be subject to approval of Project Manager.

23.0 NAME PLATES AND LABELS

All switchgears and ACDC distribution boards etc. shall be provided with prominent, engraved identification plates. The module identification plate shall clearly give the feeder number and feeder designation. For single front switchboards, similar panel and board identification labels shall be provided at the rear also. Language shall conform to the requirements stipulated elsewhere in the technical specification..

All name plates shall be of non-rusting metal or 3-ply lamincoid with white engraved lettering on black back ground. Inscriptions and lettering sizes shall be subject to Project Manager's approval.

Suitable plastic sticker labels shall be provided for easy identification of all equipment, located inside the panel or module. These labels shall be positioned so as to be clearly visible and shall give the device number as mentioned in the module wiring drawings.

24.0 ELECTRIC MOTORS (LV)

24.1 Codes and Standards

All motors shall conform to the latest revisions of the relevant IEC, Indian Standards, British Standards given in the schedules, except where modified or supplemented by this Specification.

The design, manufacture, installation and performance of motors shall conform to the provisions of latest Indian Electricity Act and Indian Electricity Rules. Nothing in these specifications shall be construed to relieve the bidder of his responsibility in this regard.

In case of contradiction between this specification and IS or BS or IEC, the stipulations on this specification shall prevail.

National Electrical Code for Hazardous locations and relevant NEMA standard shall also be applicable for motors located in hazardous location.

24.2 Service conditions and temperature rise

Unless otherwise specified, machines shall be designed for a maximum ambient air temperature of 50C. Accordingly the temperature rise of the stator winding by resistance method over the ambient air temperature shall not exceed 70C.

For applications where the motor temperatures may be appreciably affected by conducted or radiated heat, the amount of heat must be specified by the bidder and the appropriate temperature rises agreed.

24.3 AC Motors

24.3.1 General

All AC motors shall be of squirrel cage type, unless otherwise specified and shall be suitable for direct on line starting.

Each motor shall be assigned a maximum continuous rating (MCR) corresponding to 70C temperature. Maximum continuous motor rating shall be at least ten percent above the maximum load demand of the driven equipment at designed capacity.

Rated voltage for AC motors shall be as given below for various MCR's of the motor, unless specified otherwise:

- From 0.2 kW to 220 kW 415 V, three phase, 50 Hz
- Below 0.2 kW 240 V, single phase, 50 Hz

Voltage and frequency variations shall be as per clause 3.3 of IS 325.

The lowest voltage at the motor terminals throughout the starting period, with which the driven equipment shall satisfactorily start up even under the most arduous conditions specified, shall be 85% for motors rated up to 110 kW, and 80% for motors rated above.

The accelerating torque at any speed with the lowest starting voltage shall be at least ten (10) percent of rated full load torque of the motor.

The motors shall be suitable for two starts in succession under the specified conditions of load, torque and inertia, with the motor initially at its normal running temperature.

The ratio of locked rotor kVA at rated voltage to rated kW (MCR corresponding to 70C temperature rises) shall not exceed the following (without any further tolerance):

Motor MCR kW	Start kVA/Rated kW
Up to 110kW	1.0
Above 110kW	10.0

When tests to determine the breakaway starting current of cage induction motors are taken at reduced voltage, due allowance shall be made for the effect of saturation. The estimated value of breakaway starting current at rated voltage shall be given on all test certificates.

All motors shall be so designed that the maximum inrush currents and locked rotor and pull out torque, developed by them at 110% of the rated voltage, do not endanger the motor or the driven equipment.

The pull out torque at rated voltage shall not be less than 200 percent of the full load torque.

Motors for reciprocating compressors etc. shall be specially designed/rated to withstand the torque pulsation produced by the driven equipment.

24.3.2 Transient recovery

The motors shall be capable of resuming normal operation after a system disturbance causing temporary loss of supply voltage for periods of up to 0.2 second (fault clearance time), followed by sudden restoration to 70 percent rated voltage. From this voltage the motors shall be capable of acceleration and ultimate recovery under the most arduous load conditions.

24.4 DC Motors

DC motors shall comply with IS 4722 and shall be shunt wound type rated for 220V. Motor MCR kW rating at 50C ambient shall be at least ten percent higher than the power requirement of the driven equipment under the most onerous operating conditions foreseen during the plant's life.

DC motors which are to operate from batteries shall be capable of operating continuously under actual service conditions at any voltage between 190V and 240V.

DC motors supplied from rectifier equipment connected to AC power supplies shall meet the voltage and frequency variations specified for AC motors.

Rectifier equipment shall be capable of meeting the condition of transient recovery given above for AC motors and shall be provided with the necessary current limiting devices.

The pull-out torque of DC motors at the rated voltage shall not be less than 200 percent of the full load torque.

24.5 Enclosure and method of cooling

The following types of enclosure may be supplied:

- Totally enclosed, fan ventilated.
- Totally enclosed, closed air circuit, integral heat exchanger.
- Totally enclosed, closed air circuit, machine mounted heat exchanger.

In all cases protective enclosure and method of cooling of motors shall be IP 54 and IC 0141 in accordance with IS 4691 and IS 6362 respectively.

Cooling fans shall be directly driven from the motor shaft.

Motors situated outdoors or exposed to the weather shall be weather protected (IPW-55).

All totally enclosed type of motors shall have a dust tight construction with suitable means of breathing and of drainage to prevent accumulation of water from condensation. Drain holes shall exclude bodies greater than 6 mm diameter.

24.6 Constructional features

All components shall be of adequate mechanical strength and robustness and shall be constructed of metal unless otherwise approved. Glass fibre or plastic components, where employed, shall be of adequate design and robustness taking into account the conditions of service required and the effects of operating temperatures, ageing and thermal stability of the material. The material shall be resistant to flame propagation.

Rotors shall be so designed as to keep the combined critical speeds with the driven equipment away from the running speed by at least 20%.

Motors and their major components such as stators, rotors, terminal boxes, bearings and heat exchangers shall be designed to be readily interchangeable as integral units.

All motor rotors shall be dynamically balanced.

The enclosures shall be designed to provide an effective sealing between the primary and secondary air circuits.

The radial air gap between stator and rotor shall have an adequate margin to minimise the possibility of rubbing between the stator and rotor due to eccentric positioning, play and wear, shaft deflection due to rotor weight and unbalanced magnetic pull etc. The minimum radial air gap for all motors shall be in accordance with Clause 5.1.5 of IS 6381.

All requirements of clause 5.1.4 of IS 6381 shall also be complied with.

All the induction motors shall be capable of running at 75% of rated voltage for a period of 5 minutes.

Induction motors shall be designed to be capable of withstanding the voltage and torque stresses developed due to the difference between motor residual voltage and incoming supply voltage equal to 150% of the rated motor voltage during fast changeover of buses. The necessary features incorporated in the design to comply with this requirement shall be clearly indicated in this proposal.

24.7 Variable speed motors

Variable speed motors shall be such that the speed can be continuously adjusted over the required range. The speed control gear shall be provided with an interlock to ensure that the motor can only be started when its control sequence is at the correct setting. When the motor is switched off, the speed control sequence shall automatically return to this position.

24.8 Brush gear, commutators and slip-rings

Brush gear, commutators and slip-rings shall be designed to operate without injurious sparking and to run for at least three months without the need for adjustment or replacement of brushes.

Brushes shall be of electro graphite or metal graphite type. Adequate precautions shall be taken to protect the windings, commutators, slip-rings and brush gear against deposits of entrained carbon dust.

Removable covers shall be fitted to provide access to the brush gear, commutators and slip-rings. For totally enclosed type motors, windows shall be provided to permit observation of the brush gear whilst the motor is running.

Brush holders shall be of non-ferrous materials and located securely to accurately position the brushes on the commutator. Means for adjusting brush pressure and brush assembly shall be provided.

24.9 Internal electric heaters

Internal electric heaters shall be provided on motors rated above 30 kW, to maintain the windings in a dry condition during periods of standstill. The heater shall be suitable for use on a 240V, 50 Hz, AC supply.

24.10 Lifting facilities

All heavy parts of the motors shall be provided with adequate arrangements for lifting or handling during erection or overhaul.

All material used for equipment construction including castings and forging etc. shall be of tested quality as per relevant codes and standards. No welding shall be carried out on cast iron components for repair or any other purpose.

24.11 Winding and insulation

Winding insulation shall be of class B or better and of proven high quality and reliability.

All winding insulation shall be non-hygroscopic, oil resistant and of materials resistant to flame propagation. All windings shall be impregnated and suitably processed to effectively seal them to prevent deterioration from adverse environmental conditions at site during the installation period and also during normal operation.

All winding overhangs and leads shall be adequately supported, braced and blocked to provide sufficient rigidity during all normal conditions of service.

Cage windings and all joints shall be designed to give an adequate safety factor on fatigue due to thermal and mechanical stresses, taking into account the specified starting and running conditions. The short-circuiting and rings shall be of joint less construction. All electrical joints and connections shall be of brazed or welded construction.

Motors shall be designed to give a life endurance of at least 18000 starts.

24.12 Bearings

Bearings shall be of rolling type. Vertical motors shall normally have rolling type guide and thrust bearings.

Bearings shall be designed to prevent ingress of dust and water and shall be sealed against leakage of lubricant along the shaft.

When the motor shaft is not located axially by its own bearings, it shall be permanently marked to indicate its normal running position and the extent of float in either direction.

Bearings shall comply with the relevant Indian or International Standards. The bearing housing shall be correctly packed with lithium based grease at the time of assembly. Construction shall be such that the bearings can be dismantled without risk of damage.

For direct drives, bearings shall have an expected life of at least 40,000 running hours. For motors with significant external radial or axial loads, e.g. belt drives, bearing shall have a life of at least 15000 running hours. The bearing assembly shall be provided with a grease relief device to eject any surplus grease in to a separate container.

Lubrication shall be possible without removal of the guarding. All grease nipples, oil cups and dip sticks shall be readily accessible.

24.13 Heat exchangers

An adequate margin shall be included in the design of heat exchangers to allow for fouling of cooling tubes or ducts under service conditions. Provision shall be made for the easy cleaning of the cooling tubes or ducts, preferably on load.

The cooling tubes or ducts shall be adequately braced and supported to prevent vibration and premature fatigue or fracture.

24.14 Noise level

Noise levels shall comply with BS 4999, Part-51.

24.15 Vibration level

The double amplitude of vibrations as measured at motor bearings shall be within the limits specified in IS 4729, and the limits specified for the driven equipment.

24.16 Earthing terminals

Two independent earthing points shall be provided in accordance with IS 3043(1966), on opposite sides of the motor for bolted connection of Employer's earthing conductor.

24.17 Terminal boxes and associated fittings

Terminal boxes for motors rated above 110 kW shall be capable of withstanding a system fault level of 31 MVA for 0.12 seconds.

Unless otherwise approved, the terminal box shall be capable of being turned through 360 degrees in steps of 90 degrees.

415 volt terminals shall be suitable for receiving 1.1 kV grade PVC or XLPE, unarmoured or armoured power cables.

Only three line terminals need be brought out from each three phase primary winding. All inter phase connections whether star or delta shall be made inside the machine.

Marking of all terminals shall be in accordance with IS 4728.

Leads from terminals to the windings shall be adequately sized and braced to withstand heating and forces produced by maximum fault current.

Cable boxes and terminations shall be designed to enable easy disconnection and replacement of cables.

All joints other than those on cable glands shall be gasketed with neoprene, neoprene bonded cork or other approved material.

For single core cables, gland plates shall be effectively non-magnetic.

The following shall be supplied along with each motor :

1. Crimping type tinned copper lugs for power cables, with all necessary hardware.
2. Compression type tinned brass cable glands for power cables (to be supplied loose).
3. Removable type undrilled gland plate.
4. Terminal boxes shall be of weather proof construction with a degree of protection of IP-55. At least one motor of each batch shall be type tested to comply with the following : the terminal boxes shall be subject to an internal air pressure of 0.207 bar g for 12 hours. After this period the pressure shall not be less than 0.104 bar g (after correcting for any change in temperature).

24.18 Rating plate

In addition to the requirements as called for in General Technical Clauses and relevant IS, the rating plate shall indicate the following:

- Maximum continuous rating in kW for 70C temperature rise.
- Bearing identification numbers (in case of ball or roller bearings) and recommended lubricant.

24.19 Paint and finish

All external parts shall be finished and painted to produce a neat and durable surface which would prevent rusting and corrosion. The equipment shall be thoroughly degreased, and sharp edges and scales removed and treated with one coat of primer and two coats of grey enamel paint. Motor colour codes shall comply with the requirements indicated elsewhere in this Specification.

All fasteners used in the construction of the equipment shall be either of corrosion resistant material or electro galvanised to service condition 4. Current carrying fasteners shall be either of stainless steel or high tensile brass or copper.

24.20 Tests

Induction motors shall be subjected to the following routine and type tests.

24.20.1 Routine Tests

Visual Checks of the following:

- Marking on rating plates
- Appearance and painting
- Location and details of terminal boxes and accessories.
- In order to observe compliance to degree of protection, following test will be performed. It shall not be possible to insert a feeler gauge of 1 mm thick in the enclosure or flange faces.

Dimensional checks

Measurement of Insulation Resistance (IR) of windings, and space heaters.

Measurement of winding resistance, and space heater resistance at ambient temperature.

High voltage test on main windings, and space heaters.

IR measurement after HV test in main windings, and space heaters.

No load running test (reading of current, voltage input and speed measurement).

Measurement of bearing temperature during steady state conditions.

Vibration measurement at rated speed and rated voltage, also measurement of vibration during coasting down.

Reduced voltage running test at no load

Locked rotor test.

Phase sequence polarity check and check for terminal markings.

Over speed test

Measurement of air gap

Functional check on auxiliaries

24.20.2 Type Tests

All tests as listed under routine tests

Measurement of noise at no load

Locked rotor test - measurement of VA power input

Momentary overload test

Temperature rise test at rated conditions as well as at maximum input conditions (during heat run test, measurement of bearing temperature, winding temperature, core temperature, coolant flow and coolant temperature). In case the temperature rise test is carried at other load than rated load, specified approval for the test method and procedure shall be obtained from the Project Manager.

Degree of protection test for the enclosure followed by IR, HV and no load run test.

Terminal box - fault level withstand test and pressure test.

Pull out torque measurement

Measurement of no-load starting time.

24.20.3 DC motors

DC motors shall be subjected to all routine and type tests as per IS 4722. In addition, following tests shall be carried out:

- Noise level measurement as type test.
- Vibration measurement as routine test
- Degree of protection test as per IS 4691 as type test.

24.21 Junction boxes and cables

Design and selection of all the components shall be made with a good margin of safety factor.

The equipment shall be installed indoor.

The reference ambient temperature outside the equipment shall be taken as 50C and relative humidity as 100%.

25.0 JUNCTION BOXES

25.1 Construction

Bidder shall supply and install junction boxes complete with terminals as required.

Junction boxes shall be suitable for mounting on walls, columns, structures etc. The brackets, bolts, nuts, cable-glands, screws and all other accessories required for the erection shall be included in the Bidders scope.

Junction boxes shall be of square or rectangular type of 2.0 mm CRCA sheet steel and shall have bolted cover with good quality gasket lining.

Junction box and covers shall be hot dip galvanised.

All the terminals blocks of ESSEN make or equivalent shall be rated for 1100V and shall be of stud type. Each terminal shall be suitable for connecting two 2.5 mm² copper conductor.

All terminals shall be complete with insulated barriers, terminals studs, washers, nuts, locknuts, identification strips etc.

Junction boxes located inside shall have IP-54 protection as per IS 2147. Junction boxes located outside shall have IP-55 protection as per IS 2147.

Junction boxes shall be provided with one earthing terminal suitable for galvanised steel conductor.

The general arrangement, cross sectional details and other technical details are to be submitted in the form of drawing for Project Manager's approval.

25.2 Interconnecting cables

All cables between junction box and field devices shall be stranded copper conductor, PVC insulated, extruded PVC inner sheathed, single galvanised steel wire armoured and overall PVC sheathed 1.1 kV grade and shall conform to IS 1554. The minimum size of cable used shall be 2.5 mm² copper conductor. All cables shall be supplied by the Contractor.

26.0 CONDUIT AND CONDUIT ACCESSORIES

The bidder shall supply and install all rigid steel conduit, flexible conduits, Hume pipes etc. complete with accessories such as tees, bends, adaptors and couplings as required for cabling work between various field devices to junction boxes.

Bharat Heavy Electricals Limited

Project: 400/220 kV GIS SUB STATION AT ERSAMA, PARADEEP, ODISHA

Technical Specification: 220V Lead Acid Plante type Battery Bank along with accessories

Doc No. TB-420-316-025A Rev 00

Contents

SECTION 4: ANNEXURES

ANNEXURE-A: Compliance Certificate of Technical Specification 2
ANNEXURE-B: Deviation/ Change Request of Technical Specification 3
ANNEXURE-C: Guaranteed Technical Particulars 4
ANNEXURE-D: Technical Checklist..... 7

Bharat Heavy Electricals Limited

Project: 400/220 kV GIS SUB STATION AT ERSAMA, PARADEEP, ODISHA

Technical Specification: 220V Lead Acid Plante type Battery Bank along with accessories

Doc No. TB-420-316-025A Rev 00

ANNEXURE-A: Compliance Certificate of Technical Specification

The bidder shall confirm compliance to the following by signing and stamping this compliance certificate and furnishing same with the offer.

1. The scope of supply, technical details, construction features, design parameters etc. shall be as per technical specification & there are no exclusion/ deviation with regard to same.
2. There are no deviation(s) with respect to specification other than those furnished in the schedule of deviations.
3. Only those technical submittals which are specifically asked for in Notice Inviting Tender (NIT) to be submitted at tender stage shall be considered as part of offer. Any other submission, even if made, shall not be considered as part of technical offer.
4. Any comments/ clarifications on technical/ inspection requirements furnished as part of bidder's covering letter shall not be considered by BHEL, and bidder's offer shall be construed to be in conformance with the specification.
5. Any changes made by the bidder in the price schedule with respect to the description/ quantities from those given in 'BOQ' of the specification shall not be considered (i.e., technical description & quantities as per the specification shall prevail).

Date:
Signature

Bidder's Stamp &

Bharat Heavy Electricals Limited

Project: 400/220 kV GIS SUB STATION AT ERSAMA, PARADEEP, ODISHA

Technical Specification: 220V Lead Acid Plante type Battery Bank along with accessories

Doc No. TB-420-316-025A Rev 00

ANNEXURE-B: Deviation/ Change Request of Technical Specification

Bidder shall list out all technical potential deviation/ change request (s) along with clause with respect to technical specifications.

Sl. No.	Page No.	Clause No.	Deviation	Reason/ Justification(s)
---------	----------	------------	-----------	--------------------------

Any deviation not specifically brought out in this section shall not be admissible for any commercial implication at later stage. Except to the technical deviations listed in this schedule, bidder's offer shall be considered in full compliance to the tender specifications irrespective of any such deviation indicated / taken elsewhere in the submitted offer.

Date:

Bidder's Stamp & Signature

Bharat Heavy Electricals Limited

Project: 400/220 kV GIS SUB STATION AT ERSAMA, PARADEEP, ODISHA

Technical Specification: 220V Lead Acid Plante type Battery Bank along with accessories

Doc No. TB-420-316-025A Rev 00

ANNEXURE-C: Guaranteed Technical Particulars

SCHEDULE OF GUARANTEED TECHNICAL PARTICULARS FOR 220 VOLT 645 AH LEAD ACID STORAGE BATTERY

1	Manufacturer's name and address :			
2	Conforming to standards.			
3	Type and designation as per IS.			
4	Manufacturer's type and designation			
5	Capacity of battery bank at the following discharge rates at 27°C	Cap. AH	Rate of Disch. Current	End Cell voltage
	a. 15 minutes. b. 30 minutes. c. 45 minutes. d. 1 hour e. 2 hours f. 3 hours. g. 4 hours. h. 5 hours. i. 6 hours. j. 7 hours. k. 8 hours. l. 9 hours. m. 10 hours.			
6	Number of cells in the battery.			
7	Method of interconnection between cells.			
8	Maximum short circuit current of battery when short circuit is at the end of terminals			
9	Recommended float-charging voltage across the battery terminals (volts).			
10	Recommended boost charging voltage across battery terminals (volts).			
11	Time required for boost charging from discharged conditions (in hours).			
12	Recommended trickle / float charging rate			
13	Recommended boost charging rate.			
14	Trickle charging current range / cell.			
15	Shelf life of charged battery bank.			
16	Open circuit voltage of battery bank when fully charged.			
17	AH capacity at 10 hours rate at room temperatures of:-			
	a. 15°C. b. 27°C c. 50°C			
18	Cell Particulars:-			
	a. Material of container. b. Overall dimensions of each cell. c. Weight of cell complete with acid.			
19	Voltage:-			

Bharat Heavy Electricals Limited

Project: 400/220 kV GIS SUB STATION AT ERSAMA, PARADEEP, ODISHA

Technical Specification: 220V Lead Acid Plante type Battery Bank along with accessories

Doc No. TB-420-316-025A Rev 00

	a. Open circuit voltage of cells. b. Float charging voltage. c. Boost charging voltage.
20	Type of material / thickness / dimension of positive plates.
21	Type of material / thickness / dimension of negative plates.
22	Separators:-
	a. Type. b. Materials. c. Thickness of separator.
23	Type of valve provided.
24	Internal resistance of each cell at
25	Clearance in mm between.
	a. Top of plates and top of container. b. Bottom of plates and bottom of container. c. Edges of plates and inner surface of container.
26	Maximum ambient temperature that the cells can withstand. Without injurious effect.
	a. Continuously. b. Short periods (duration to be stated along with temperature).
27	Maximum number of charge / discharge cycles that the cell can withstand.
28	Ampere-hour efficiency at ten-hour discharge rate.
29	Watt-hour efficiency at ten hour discharge rage
30	Estimated life of cell under normal operating conditions (in years) % change in life of battery for change in ambient temperature 27 degree centigrade.
31	a. Maximum short circuit current per battery. b. Allowable duration of short circuit.
32	Short circuit current for a dead short across the Battery terminals when.
	a. Float at 2.1V per cell b. Boost charge to 2.75 V per cell.
33	Recommended floating voltage per cell and the Minimum variation.
34	Recommended interval at which battery should be Discharged at 10-hour rate and quick charged.
35	Recommended storage period of a fully charged battery.
36	Inter cell connector.
	a. Inter-cell connector furnished? (Yes/No). b. Type of inter-cell connector (bolted or others)? c. Materials of inter cell connector.
37	Inter-row, inter tier connectors and end take- off furnished? Description. Size current rating type and material
38	Battery stack / rack.

Bharat Heavy Electricals Limited

Project: 400/220 kV GIS SUB STATION AT ERSAMA, PARADEEP, ODISHA

Technical Specification: 220V Lead Acid Plante type Battery Bank along with accessories

Doc No. TB-420-316-025A Rev 00

	<ul style="list-style-type: none">a. Outline dimensions.b. Type and material.c. Anti-acid coating type.d. Number of trays.e. Height of bottom tier from ground level.f. No. of cells which can be stacked in tray.g. Dimensions of each tray.
39	Total shipping weight of battery units.
40	A dimensional layout drawing of the battery stock / rack along with battery attached with the tender (yes /No)
41	The following characteristic curves to be furnished along with the tender (yes/No).
	<ul style="list-style-type: none">a. Battery discharge curves at various rates between 1 minute and 10-hour rate.b. Curves showing the relation between the cell voltage and charging current, when charged at:<ul style="list-style-type: none">(i) Finishing rate.(ii) High starting rate.(iii) Two step charging by starting and finishing rate.

Bharat Heavy Electricals Limited

Project: 400/220 kV GIS SUB STATION AT ERSAMA, PARADEEP, ODISHA

Technical Specification: 220V Lead Acid Plante type Battery Bank along with accessories

Doc No. TB-420-316-025A Rev 00

ANNEXURE-D: Technical Checklist

Sl. No.	Parameters	Required value 220V BATTERY	Bidder's Confirmation	Reasons for non-compliance
1.	Battery Type	Lead Acid plante	YES	
2.	Battery Voltage	220V	YES	
3.	Capacity	645 AH	YES	
4.	Design Ambient Temperature	50deg. C	YES	
5.	Max. Battery Bank Voltage	237.5V	YES	
6.	Min Battery Bank Voltage	198V	YES	
7.	Nominal Discharge Voltage per cell	2V	YES	
8.	Design & Construction details	As per clause A7.0 of Section-2	YES	
9.	Battery Racks	As per clause A8.0 of Section-2	YES/NO	
10.	Connectors and Fasteners	As per clause A9.0 of Section-2	YES/NO	
11.	Accessories of Battery Bank included in the scope of supplies	As per clause 3.2 of Section-1	YES/NO	
12.	Supervision of ETC of Battery quoted in line with Section-1	Item no. B.1, Bill of Quantities, Section-1	YES/NO	
13.	Supply of electrolyte for first filling plus 10% extra with the battery bank	As per clause A10 h) of Section-2	YES/NO	
14.	Arrangement for connection for cell tapping provided for continuity during boost charging?	YES	YES	

2. Confirmation regarding sizing calculation for deciding no. of battery cells (to be submitted during detailed engineering) as per requirement specified in Section-1 Clause-2.

YES

3. TYPE TESTS

3.1. Whether the offered equipment has been type tested within Five years from the date of bid opening (Date of bid opening is 11.02.2022) and valid reports are available.

YES /NO

3.2. If case, the reports are not found complete / valid at contract stage, such type tests shall be carried out without any cost / delivery implication.

YES