

# JOB STANDARD SPECIFICATION FOR ANALYSER SHELTER

Rev. No	Date	Purpose	Prepared by	Checked by	Approved by
0	18.06.2009	Issued as Job Standard Specification	AR	AA	RG

**Abbreviations:**

AARH	Arithmetic Average Root Height
CMRI	Central Mining Research Institute
DCS	Distributed Control System
DPDT	Double Pole Double Throw
Deg C	degree centigrade
ERTL	Electronics Regional Testing Laboratory
NPT	National Pipe Threads

---

CONTENTS

1.0	GENERAL
2.0	DESIGN AND CONSTRUCTION
3.0	NAME PLATE
4.0	INSPECTION AND TESTING
5.0	SHIPPING
6.0	REJECTION

## 1.0 GENERAL

### 1.1 Scope

1.1.1 This specification, together with the data sheets covers the requirements for the design, materials, nameplate marking, inspection, testing and shipping of analyser shelter complete with accessories, which are required for housing industrial process analysers and their associated piping, wiring and auxiliary instruments.

1.1.2 The related standards referred to herein and mentioned below shall be of the latest editions prior to the date of the purchaser's enquiry:

ANSI/ASME American National Standards Institute/American Society of Mechanical Engineers.

B 1.20.1 Pipe Threads General Purpose (Inch)

B 16.5 Pipe Flanges and Flanged Fittings NPS½ through NPS24

B 16.20 Metallic Gaskets for Pipe Flanges, Ring Joint, Spiral wound and Jacketed.

EN 10204 Inspection Documents For Metallic Products.

IEC-60079 Electrical Apparatus for Explosive Gas Atmosphere.

IEC-60529 Degree of Protection Provided by Enclosures (IP Code).

IEC-61000-4-X Electromagnetic Compatibility for Industrial Process Measurement and Control Equipment.

IS-13947 Specification for Low Voltage Switch gears and Control gears.

IS-2148 Electrical Apparatus for Explosive Gas Atmospheres-Flame proof Enclosures d'.

IS-5780 Intrinsically safe electrical apparatus and circuit electrical equipment with type of protection 'i'.

NFPA 496 National Fire Protection Association

1.1.3 In the event of any conflict between this specification, data sheets, statutory regulations, related standards, codes etc., the following order of priority shall govern:

- a) Statutory Regulations
- b) Data Sheets
- c) Standard Specification
- d) Codes and Standards

1.1.4 In addition to compliance to purchaser's specification in totality, contractors extent of responsibility shall include the following:

- a) Purchaser's data sheets specify the minimum acceptable materials. Alternate superior material of construction shall also be acceptable provided contractor assumes complete responsibility for the selected materials for their compatibility with the specified operating conditions.

## 1.2 Bids

- 1.2.1 Contractor's quotation shall be strictly as per the bidding instructions to contractor attached with the material requisition.
- 1.2.2 Whenever a detailed technical offer is required, contractor's quotation shall include the following:
- a) Compliance to the specifications.
  - b) Whenever the requirement of detailed specification sheet for analyser shelter is specifically indicated, a detailed specification sheet for each analyser shelter shall be furnished, which shall provide all the details regarding type, material of construction as applicable. The material specifications and the units of measurement for various parts in contractor's specification sheet shall be to the same standards as those indicated in purchaser's data sheet.
  - c) Proven references for each offered analyser shelter inline with clause 1.2.3 of this specification.
  - d) Contractor must furnish the pressurization / purging details clearly indicating the following information and the standard to which the pressurisation of shelter is complied to:
    - i) No. of volumes of air changes for which shelter have been designed
    - ii) Pressure maintained within the Analyser Shelter
    - iii) Design code to which shelters pressurization are being complied
  - e) A copy of approval from local statutory authority, as applicable, such as Chief Controller of Explosives (CCE), Nagpur or Director General of Mines Safety (DGMS) in India, for the electronic instruments including HVAC installed in electrically hazardous area inside and outside the shelter along with:
    - i) Test certificate from recognised test house like CMRI/ERTL etc. for flameproof enclosure/intrinsic safety, as specified in the data sheet, as per relevant standard for all Indian manufactured equipments or for items requiring DGMS approval.
    - ii) Certificate of conformity from agencies like LCIE, BASEEFA, PTB, CSA, FM, UL etc. for compliance to ATEX directives or other equivalent standards for all equipments manufactured outside India.
  - f) Deviations on technical requirements will not be entertained. In case contractor has any valid technical reason, they must include a list of deviations tag number wise, summing up all the deviations from the purchaser's data sheets and other technical specifications along with the technical reasons for each of these deviations.
  - g) Catalogues giving detailed technical specifications, model decoding details and other related information for each type of analyser shelter covered in the bid.

- 1.2.3 All items, as offered, shall be field proven and should have been operating satisfactorily individually for a period of minimum 4000 hours on the bid due date in the process conditions similar to those as specified in the purchaser's data sheets. Items with proto-type design or items not meeting proveness criteria specified above shall not be offered.
- 1.2.4 All documentation submitted by contractor including their quotation, catalogues, drawings, installation, operation and maintenance manual etc. shall be in English language only.
- 1.2.5 Contractor shall also quote for the following:
- a) Unit rate of any special items.
  - b) Any special tools and tackles needed for maintenance work. In case no special tools are necessary for maintenance for the offered shelter, contractor must certify the same in their offer.

### 1.3 Drawings and Data

- 1.3.1 Detailed drawings, data, catalogues and manuals required from the contractor are indicated by the purchaser in vendor data requirement sheets. The required number of reproducible, prints and soft copies shall be dispatched to the address mentioned, adhering to the time limits indicated.
- 1.3.2 Final documentation consisting of design data, installation manual, operation and maintenance manual etc. submitted by contractor after placement of purchase order shall include the following, as a minimum:
- a) Specification sheet for analyser shelter and its accessories.
  - b) Certified drawing for each analyser shelter, which shall provide following details;
    - i) Overall / Mounting Details of the complete shelter in millimetres
    - ii) Clearance space required for maintenance work.
    - iii) Schematic diagram for the complete assembly including utilities required for the shelter.
  - c) Copy of type test certificates
  - d) Copy of the test certificates for all tests indicated in clause 4.0 of this specification.
  - e) Installation procedure for analyser shelter.

## 2.0 DESIGN AND CONSTRUCTION

### 2.1 General requirements

- 2.1.1 The analyzer shelters for housing industrial process analyzers and their associated piping, wiring and auxiliary instruments. Analyzer shelter are:
- a) To create a space within a hazardous area (Zone-1) in which under normal operating conditions a non hazardous atmosphere exists, so that testing or calibration of analyzers and maintenance can be performed with opened casings and electrical circuits alive.
  - b) To create a controlled environment in which analyzers and their associated equipment are adequately protected against adverse weather conditions.

- 2.1.2 The analyzer shelter shall be fully prefabricated, assembled, tested and shall be supplied as ready-to-install at project site with all items including analyzers and their accessories duly mounted, wired, tubed and tested before shipment
- 2.1.3 The arrangement of equipments shall be such that it provides enough access to front/back/sides of the equipments as necessary during normal operation as well as during start up and maintenance. Sufficient space shall be provided for workbench, signal and power cables entries and routing, power sockets, utility, supplies, auxiliary and control equipments. Suitable arrangements shall also be made for locating devices like recorder, portable printers etc. near each equipment.
- 2.1.4 The housing shall be provided with fluorescent lamps to provide an illumination of 300 ~ 400 lux or more at the floor level, convenient for reading & carrying out maintenance and adjustments on the instruments/ equipments. Fluorescent lamps shall also be provided outside of the analyser shelter for carrying out the repair / adjustments on the equipments mounted on outside the analyser shelters. eg. Sample conditioning systems etc.
- 2.1.5 Shelters shall be equipped with all safety measures like panic bar at the doors, Emergency alarm push buttons, LEL gas (hydrocarbon) detectors, Fire detection system, warning panels, Fire extinguishers, wash basin etc.
- 2.1.6 In addition to warning panel alarms, an alarm annunciator system shall also be provided in the shelter. This annunciator system shall be provided in each analyser shelter and shall provide the following alarms for each analyser and shelter;
- Analysers failure alarm
  - Analysers low flow alarm
  - Analysers under calibration
  - Analysers shelter temperature high
  - Analysers shelter humidity high
  - Component concentration high (Provide 3 Alarms for NO<sub>x</sub>, SO<sub>x</sub> and CO)
- These alarms shall also be available in control room in both analyser console and DCS.
- 2.1.7 Shelter shall be provided with ventilation and air-conditioning to maintain the temperature and humidity suitable for the analyzers stable performance and human comfort.
- 2.1.8 All electrical equipments, fittings, fixtures shall be Flame proof suitable for hazardous area classification.
- 2.1.9 Minimum shelter size shall be as given in job specification. Contractor to note analyzer shelter shall be sized considering 25 % additional spare space for future. Contractor to consider all other factors within the Analyzer shelter like A.C . System load, power load etc. considering analysers to be installed in future within the 25% additional space.
- 2.1.10 The design shall be in compliance with the electromagnetic compatibility requirements as per IEC 61000-4.

**2.1.11 End Connection**

2.1.11.1 End Connections shall be as specified in purchaser's data sheet.

2.1.11.2 In case end connection of manufacturer's standard instrument is different than that specified in the purchaser's data sheet, contractor should include the required expander/reducer assembly in their scope of supply.

2.1.11.3 Unless otherwise specified, end connection details shall be as below:

- a) Threaded end connections shall be NPT as per ANSI/ASME B 1.20.1.
- b) Flanged end connections shall be as per ANSI/ASME B 16.5
- c) Grooves of ring type joint flanges shall be octagonal as per ANSI 16.20.
- d) Flange face finish shall be as per clauses 6.4.4.1, 6.4.4.2 and 6.4.4.3 of ANSI/ASME B 16.5. The face finish as specified in the data sheets, shall be follows:

125 AARH : 125 to 200 AARH

63 AARH : 32 to 63 AARH

**2.1.12 Power Supply**

- a) Unless otherwise specified, the following power supplies shall be provided for each shelter at one point near the shelter by owner. Further distribution step down etc. as per requirement shall be done by the bidder:
  - i) 415V 50Hz 3 phase with neutral or 230 V 50 Hz for the Air conditioning system (To be decided by contractor based on actual load requirement). 230V 50Hz Single phase required for lighting (internal and external) system of the shelter shall be derived from 415 V by contractor.
  - ii) 110VAC 50Hz Single phase for analyser, alarm system, horn and other related accessories.
- b) The supply voltage fluctuation of  $\pm 10\%$  and supply frequency fluctuation of  $\pm 3\text{Hz}$  from the specified value, shall not affect the instrument performance.
- c) Main switches for all three-power supply shall be mounted outside the analyser house, which shall be weather proof to IP66 and explosion proof suitable to the hazardous area classification. The three power supply cables will be terminated after the main switches inside the shelter in different junction boxes with terminals and switch fuse unit for power distribution to the relevant equipments/items. Individual switches shall be provided for each instrument for independent de-energisation of the items.  
 'Power Supply on' indication shall be provided on the main power supply line to each analyser on PDB.
- c) Two power sockets of 110V 50Hz and 230V 50Hz supply for electrical tools or test equipments shall be provided at two opposite corners of each shelter.

- d) Electrical area classification shall be as indicated in the job specification for outside and inside the shelter considering pressurisation failure condition. All equipments inside the analyser shelter shall be suitable for operation in area classification under pressurisation failure condition.

2.1.13 Lighting

2.1.12.1 Power supply for lighting inside and outside the shelter shall be 230 V 50 Hz.

2.1.12.2 Internal lighting shall be provided by fluorescent tube lamps to provide illumination of 200 lux minimum at all places on the floor.

2.1.12.3 External lighting shall be under overhangs to provide illumination sufficient for maintenance / repair work.

2.1.12.4 Lighting fixtures inside and outside the shelter shall be suitable to the electrical area classification given above.

2.1.12.5 Lighting switch shall be provided outside the shelter near to the main door.

2.1.14 Other Utilities

Owner shall provide following at one point near each shelter. Further necessary distribution shall be by shelter manufacturer as per the requirement.

2.1.13.1 Steam

a) Pressure : 2.5 – 5.5 Kg/sqcmg

b) Temperature : Saturated

c) Line size connection : 1.0" NBNPT (M) with valve

2.1.13.2 Instrument Air

a) Pressure : 4.0 - 6.0 Kg/sqcmg

b) Dew Point : (-) 40 DEG C at atmospheric pressure

c) Line size connection: 1.0" NBNPT (M) with valve

2.1.13.3 Cooling water

a) Pressure : 3.5 - 5.0 kg/sqcmg

b) Temperature: 33 DEG C

c) Connection size: 1.0" NBNPT (M) with valve

2.1.13.4 Nitrogen

a) Temperature : Amb

b) Pressure : 5 - 8 Kg/sqcmg

2.1.15 Terminal Housing

- a) The terminal housing shall be suitable for the area classification indicated in the purchaser's data sheets. Unless otherwise specified, the enclosure shall comply with the following requirements as a minimum:

Weather proof housing: IP-65 as per IEC-60529/IS-13947

Flameproof housing: Flameproof/Explosion proof i.e., Ex (d) as per IEC 60079 / IS-2148 for explosion proof construction

Flameproof housing shall also be made weather proof.

- b) All cables shall terminate on the terminal blocks in all contractor-supplied equipments. Separate terminal blocks shall be provided for power and signal cables. Unless otherwise specified, terminals shall be suitable for terminating following conductor sizes, as a minimum:

Signal cables : 1.5 / 2.5 sq. mm

Power cables : 6 sq. mm

Separate terminal box shall be provided in case instrument terminals available as standard are not suitable to accommodate the specified conductor sizes.

## 2.2 Construction

- 2.2.1 The shelter shall be constructed using materials capable of satisfying all the functional requirements and shall not be cause of any safety hazards at any point of time.
- 2.2.2 The design and construction of the shelter shall be self-supporting type and shall be sized to house required analyzers, their sample conditioning system and other accessories. Shelters shall also be provided with suitable transportation arrangement.
- 2.2.3 The base structure of the shelter shall be constructed using suitable size 'I' beams, channels, and angles, welded properly and adequately. All structural members shall be sized to ensure structural rigidity and to prevent deformation during dragging, lifting, loading and unloading operations of the shelter.
- 2.2.4 The floor shall be fabricated from anti slip and non- corrosive Aluminium plates as a minimum, strong enough to withstand load of all equipments and at least 10-maintenance personal. It shall also be unaffected during transportation and various other obvious forces and shall be sealed to prevent any loss of ventilation pressure.
- 2.2.5 External sidewalls shall be ribbed interlocking stainless steel sheet of thickness 2mm and internal walls shall be stainless steel sheet of thickness 2mm. The walls of the shelter shall be strong enough to take load of the rack mounted analyzers, related sample conditioning system and associated accessories.
- 2.2.6 The shelter roof shall be capable of supporting the combined weight of at least 4 men without permanent deformation and shall be sealed properly to prevent loss of ventilation pressure and entry of rain and jet water.
- 2.2.7 Lifting of the complete shelter along with all analyzers, sample conditioning systems and associated accessories mounted in it shall be assured by means of suitably designed lifting lugs.
- 2.2.8 The walls and roof shall be insulated by using glass wool of high density and low thermal coefficient, of thickness approximately 100mm commensurate with the HVAC design. Contractor, if necessary, shall provide higher insulation thickness.

- 2.2.9 The shelter shall be provided with a main door and an emergency door opposite to main door. Both the doors shall be opening outwards, provided with wire reinforced safety glass window automatic spring door closer opening by simple push, fitted with panic hardware for use in case of emergency. The main door shall be provided with outside pad lock holes. Warning light shall be provided at both the Main door and the emergency door indicating the Hydro Carbon presence within the shelter.
- 2.2.10 Extension roof (overhang) made of stainless steel sheet shall be provided all along the walls of the shelter and over the sampling system for protection of the sampling system and maintenance personal from the direct weather conditions. The extension roof shall be overhung at least 1000 mm outside the analyzer shelter.
- 2.2.11 A nameplate with the analyzer shelter number shall be fixed near the main door and emergency door. Tag numbers of the analyzers shall be fixed near the main door. Tag Numbers of each analyzers and all sampling system shall be fixed near the respective items. All inlet & outlet tube/ pipes shall be provided with tag number & proper identification numbers engraved in the stainless steel plate. All electrical wires/ leads shall be identified inside the junction box/ equipment by proper plastic ferrules. All cables shall be identified with stainless steel plate engraved tag nos./ identification numbers.
- 2.2.12 Provision shall be made for keeping all fast loop devices, distribution devices outside the shelter. A suitable restriction orifice shall be provided in each sample line to limit the sample flow not exceeding thrice the normal flow in the event of tube rupture/opening of the tube down the line.

**2.3 Painting**

- 2.3.1 Analyzer shelter shall be treated and painted as follows:
  - a) All surfaces including structures shall be sand blasted and grinding done and they are smooth and free of scale, rust etc.
  - b) Chemical treatment shall be done to remove rust, oil, entrapped impurities and other foreign materials
  - c) Exterior and inside colour of shelter shall be finalised during detailed engineering.

**2.4 Tubing / Wiring**

- 2.4.1 All safety valve outlets shall be terminated in a common header of 2" NB schedule 80S Stainless Steel 304 pipe and single outlet shall be provided out side the shelter with one non-return valve and lock open type 2" ball valve. Similarly all vents to atmosphere shall be terminated in a similar 2" NB Sch 80 S SS 304 pipe and single outlet shall be provided with non-return valve and Lock open type 2" ball valve.
- 2.4.2 All atmospheric gas outlet line shall be equipped with protection from climatic condition.
- 2.4.3 All tubing work shall be done by using 1/4" OD or 1/8" OD SS tube and swagelok/ Parker/ Sandwik flareless, double compression type fittings.
- 2.4.4 All wiring/ tubing and all other erection work shall be done in accordance to API RP 550.

- 2.4.5 All cable entries/outlets in the junction boxes/ distribution boxes etc and to the analyzer shall be provided with double compression type certified flameproof cables glands suitable for the indicated hazardous area. The material of the same shall be Nickel-plated brass.
- 2.4.6 All cabling/wiring works inside the shelter shall be in accordance with the international standard/ practice being practiced in industry for similar application. However the cables shall be armoured as minimum.
- 2.4.7 Dimensions and layout of each shelter shall be provided by contractor for Purchaser / EIL review before taking up for fabrication.
- 2.5 HVAC System**
- 2.5.1 Heating ventilation and air conditioning system shall be designed sufficiently to create safe area inside the analyser shelter by supplying fresh air and a good environment by controlling the climatic condition through air conditioner or heater as required.
- 2.5.2 Air conditioning system shall be designed and provided as per " HVAC system for Analyser shelter/ room 6987-00-YA-SP-6010 Rev A".
- 2.5.3 Heating and Air Conditioning System**
- 2.5.3.1 Each Analyser shelter shall be equipped with heating and air conditioning system to keep the inside atmosphere of the shelter at a comparatively constant temperature of 26°C +/- 2 °C with humidity between 35% to 70% to obtain repeatability and reliability of the analysers and also a comfortable working environment for workmen.
- 2.5.3.2 Heating shall be done by properly designed steam coil heater placed in ventilation duct itself. Steam circuit shall be provided with thermal regulating valve for automatic control of steam flow with respect of temperature of analyser shelter if available.
- 2.5.3.3 The analyser shelter manufacturer shall submit a certificate from the statutory authority in the country of manufacture that the housing design and construction meet in general the requirements of NFPA 496.
- 2.5.3.4 The shelter manufacturer shall ensure that all electrical items used for each shelter are suitable for electrical area classification. Certificate from statutory authority shall be furnished showing the suitability of every electrical items used.
- 2.5.3.5 For Analyser shelters in safe area contractor shall provide industrial type split AC unit (1unit working + unit stand by). Contractor shall calculate the capacity of the split type air conditioner considering 25% spare heat load over and above the heat load calculated by contractor.
- 3.0 NAMEPLATE**
- 3.1 Each analyser shelter shall have a stainless steel nameplate attached firmly to it at a visible place near the main and Emergency doors, furnishing the following information:
- Tag number as per purchaser's data sheet.
  - Manufacturer's serial number (If any).
  - Manufacturer's name/trade mark.

- d) Area classification in which the shelter can be used.
- e) Size of shelter.

#### 4.0 INSPECTION AND TESTING

4.1 Unless otherwise specified, purchaser reserves the right to test and inspect all the items at the manufacturer's works.

4.2 Contractor shall submit the following test certificates and test reports for purchaser's review:

- a) Material test certificate as per clause 3.1B of EN 10204 for flanges, fittings and sheet steel.
- b) Certificate of radiography/ X-ray for header welded joints. Dye penetration test certificate shall be provided for joints where radiography/ X-ray is not possible.
- c) Dimensional verification certificate as per clause 4.3 of this specification.
- d) Hydrostatic testing of all headers.
- e) Leakage and continuity testing.
- f) Power distribution and wiring scheme check.
- g) Functional check for HVAC.
- h) Type test certificates.

#### 4.3 Dimensional Verification

4.3.1 End connection dimensional details shall be verified for all instruments and their accessories in accordance with approved drawings. In any case, the variation shall not exceed  $\pm 2.0\text{mm}$ .

#### 4.4 Hydrostatic Testing

All headers shall undergo hydrostatic testing at 1.5 times the header design pressure with water at ambient temperature. These shall not be any visible leakage during the testing.

#### 4.5 Continuity Testing

- a) All power cables shall be megger tested at minimum 600V. The insulation shall be as per IS-1554 Part I.
- b) All signal cables / wires shall be checked for continuity, termination and identification using multi-meter.

#### 4.6 Leakage Testing

All tubing and piping shall undergo leakage testing when pressurised with nitrogen at 100PsiG. No bubbles shall appear when testing with soap solution.

#### 4.7 Witness Inspection

4.7.1 Contractor shall offer all analyser shelters for pre-dispatch inspection at their works.

Following tests/checks shall be carried out, as a minimum.

- a) Physical dimensional verification and workmanship as per clause 4.3 of this specification.
- b) Leakage testing & Hydrostatic testing of tubes and headers as per clause 4.5 and 4.6 of this specification.
- c) Power distribution and wiring scheme check.

- d) Insulation resistance check.
- e) Functional check for HVAC.
- f) Review of all certificates and test reports as indicated in clause 4.2 of this specification.

4.7.2 In the event when the witness inspection is not carried out by purchaser, the tests shall anyway be completed by the contractor and documents for the same shall be submitted to purchaser for scrutiny.

#### 5.0 SHIPPING

- 5.1 All threaded and flanged openings shall be suitably covered to prevent entry of foreign material.
- 5.2 Glass windows shall be covered with thermo-coal sheet of appropriate thickness to avoid damage during transport.
- 5.3 Shipping breaks shall be provided in all equipment which are supplied in installed condition inside the analyser shelter. Equipment which are likely to damage during shipment shall be packed separately for shipment.

#### 6.0 REJECTION

- 6.1 Contractor shall prepare their offer strictly as per clause 1.2 of this specification and shall attach only those documents, which are specifically indicated in the material requisition.
- 6.2 Any offer not conforming to the above requirements, shall be summarily rejected.

## 1.0 SCOPE OF WORK

The intent of this specification is to outline the Purchaser's requirements under which the Contractor shall design, engineer, procure, manufacture, inspect & test at works, shop-paint, pack & forward, transport, supply install, test and commission of the HVAC System for Analyser Shelter/ room complete with all auxiliaries and features required for efficient & satisfactory operation. Contractor shall carry out Performance Guarantee (PG) test at site to prove the Guaranteed Parameters.

## 2.0 HVAC SYSTEM FOR ANALYSER SHELTER/ ROOM (HAZARDOUS AREA)

2.1 Analyser Shelters/ rooms shall be air conditioned and pressurised to prevent the entry of flammable gases & vapours and combustible dusts.

2.2 Air Conditioning and pressurisation shall be achieved by providing packaged type air-conditioners as per manufacturer's standard practice.

### 2.3 Codes & Standards

Following codes and standards shall be followed besides HVAC codes & standards.

- i. Electrical apparatus for Explosive gas atmosphere, IEC 60079-16.
- ii. National fire codes, NFPA-496.

2.4 Pressurisation system shall be provided for Analyser Shelter/ room. Fresh air shall be taken from safe area. Fresh air intake arrangement comprising of fresh air blower with drive (1 working + 1 standby) & back draft dampers, cleanable type filters (95%, 5 micron) and bird screen etc shall be provided. Relief dampers shall be used to exhaust room air at 5 mm WG over pressure. Shelter/ room internal positive pressure shall be maintained at 2.5 mm WG minimum. Fresh air stack with rain cap shall be of carbon steel, welded in construction of minimum 2 mm thick. Fresh air shall be taken from nearest safe area through fresh air stack in a guy wire style or through horizontal/ Vertical duct. The Ducts shall be completely leak proof while passing through hazardous area. Loss of pressurisation shall initiate an audio-visual alarm. Manual blower selector switch to alternate between the blowers shall be provided.

2.5 Fresh air make up requirements shall be calculated by the contractor based on the requirements as specified in Clause 8.3 of NFPA 496, (Latest Edition), i.e. where a release of flammable gas or vapour within an enclosure can occur either in normal operation or under abnormal conditions, protection shall be provided by diluting with air to maintain the concentration of flammable gas, vapour, or mixture to less than 25% of its lower flammable limit of any individual flammable gas or vapour entering the enclosure. However minimum 5 air changes shall be provided as per IEC 61285 for ventilation purpose. Inside temperature rise shall be limited to 5<sup>o</sup> C above ambient, by fresh air from pressurisation system, in case of failure of AC system.

Contractor shall submit the heat load calculation for review during post order stage.

2.6 Heat load on account of fresh air shall be considered while calculating the capacity of air conditioners.

2.7 All equipment shall be suitable for operation in their respective area classification.

For Analyser shelters/ rooms located in classified area (Zone - 2, Gr. IIA/IIB), HVAC unit is required to be explosion-proof in construction. All explosion-proof equipment shall be certified & approved from statutory bodies like CCE Nagpur, BIS, CMRS, DGMS for equipment sourced from India or from equivalent bodies of country of origin.

- 2.8 Chemical Filters shall be provided in the fresh air intake to protect the electronic equipment installed inside the analyser shelters/ rooms against corrosive gases like H<sub>2</sub>S, SO<sub>2</sub>, NO<sub>x</sub> etc.

### 3.0 HVAC SYSTEM FOR ANALYSER SHELTER/ ROOM (SAFE AREA)

- 3.1 Analyser shelters/ rooms are to be air conditioned and pressurised to prevent the entry of dust.
- 3.2 Air Conditioning and pressurisation shall be achieved by providing packaged type air-conditioners as per manufacturer's standard practice.
- 3.3 Pressurisation system shall be provided for Analyser Shelter/ room. Fresh air intake arrangement comprising of fresh air blower with drive (1 working + 1 standby) & back draft dampers, cleanable type filters (95%, 5 micron) and bird screen etc shall be provided. Minimum 5 air changes shall be provided as per IEC 61285 for ventilation purpose. Inside temperature rise shall be limited to 5<sup>0</sup> C above ambient, by fresh air from pressurisation system, in case of failure of AC system. Relief dampers shall be used to exhaust room air at 5 mm WG over pressure. Shelter/ room internal positive pressure shall be maintained at 2.5 mm WG minimum. Loss of pressurisation shall initiate an audio-visual alarm. Manual blower selector switch to alternate between the blowers shall be provided.
- 3.4 The above is valid in case, shelters/ rooms are safe even if gases are being taken for sampling and analysis.
- 3.5 Chemical Filters shall be provided in the fresh air intake to protect the electronic equipment installed inside the analyser shelters/ rooms against corrosive gases like H<sub>2</sub>S, SO<sub>2</sub>, NO<sub>x</sub> etc.

### 4.0 INSIDE CONDITIONS TO BE MAINTAINED

Following inside conditions are to be maintained and guaranteed by contractor throughout the year :

- Dry bulb temperature : 26°C ± 1°C
- Relative humidity : 35% to 70%

### 5.0 OUTDOOR DESIGN CONDITIONS

Outdoor design conditions, as mentioned elsewhere, shall be considered for heat load calculation.

## 6.0 SPARES

Spares for commissioning and start up as required shall be provided by contractor without any additional time & cost implication.

## 7.0 INSPECTION AND TESTING

Equipment shall be inspected at works and performance test for the inside conditions as specified shall be carried out at site by the contractor. Equipment shall be tested as part of integrated FAT. Contractor shall provide procedure for FAT/SAT. All instruments (with valid certified calibration) for measurement shall be bought by contractor at site.



MEMORANDUM OF UNDERSTANDING FOR SO2, NOx, CO & CO2 ANALYSER

MOU / TPFH / SO2, NOx, CO & CO2 ANALYSER  
REV: 00

Date : 10-11-2008  
Page: 1 of 9

**Memorandum of Understanding**

between

**M/s BHEL / FBC & HRSG**  
Trichy - 620 014

and

**M/s : ENVIRONNEMENT S.A.,**

Address:

**111, SD ROBESPIERRE 78300,  
POISSY, FRANCE**

(Vendor Code: 20525)

For supplying

**SO2, NOx, CO & CO2 GAS ANALYSER (DILUTION TYPE)**

MOU NO : MOU / TPFH / SO2,NOx, CO & CO2 ANALYSER, REV.00  
Date : 10-11-2008  
Valid upto : 10-11-2010

  
Signature  
Date  
Company  
**ENVIRONNEMENT S.A.**  
111, SD Robespierre,  
78300 POISSY  
Tel 01 39 22 38 00  
Fax 01 39 65 38 08

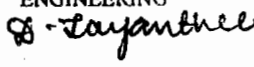
ENGINEERING  
  
**D. JAYANTHEE**  
**D. JAYANTHEE**  
E. C & Manager HRSG  
BHEL, C & I / FBC & HRSG 14,  
BHEL, Tiruchirappalli - 620 014.

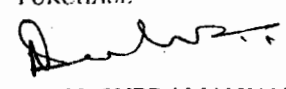
PURCHASE  
  
**N. SUBRAMANIAN**  
MANAGER  
PURCHASE / FBC & HRSG  
BHEL TIRUCHIRAPPALLI 620 014.



MEMORANDUM OF UNDERSTANDING FOR SO2, NOx, CO & CO2 ANALYSER

MOU / TPFH / SO2, NOx, CO & CO2 ANALYSER  
REV. 00

Date: 10-11-2008  
Page: 2 of 9

**SECTION 1.0: GENERAL**

- 1.1 This MOU is signed for supplying the **SO2, NOx, CO & CO2 analyser** as per the agreed standardized specification so that these details need not be discussed again and again for future supplies.
- 1.2 The various aspects covered in this MOU are as follows: -
  - 1.2.1 The general points are covered in **Section – 1.0 – General.**
  - 1.2.2 The specification requirements are covered in **Section – 2.0 – Specifications.**
  - 1.2.3 The Inspection / Testing and Packing requirements are covered in **Section – 3.0 Testing, Inspection and Packing.**
  - 1.2.4 The documents to be submitted along with the offer & after placement of Order / along with the panel are covered in **Section 4.0 - Data Sheet**
  - 1.2.5 The project specific details / data and if any customer specific requirements shall be covered in **Section 5.0 – Project Data Sheet. DEVIATION ON PROJECT RELATED INFORMATION WILL LEADS TO REJECTION OF OFFER.**
  - 1.2.6 If any differences are found between the details given in Section 5.0 and other sections, Section 5.0 shall be considered as final and the vendors shall meet this requirement for that particular project.
- 1.3 Sections 1.0, 2.0, 3.0 and 4.0 are standard and Section 5.0 alone will be furnished to the vendors for their acceptance.
- 1.4 It is agreed that no deviations will be taken standard MOU Specification by the vendors while submitting their offers against future enquiries.
- 1.5 Since the specifications are standardized and an understanding has been reached, the future enquiries will be floated on "SINGLE BID SYSTEM" only. Hence, if any offer is found with deviations, the same will be totally rejected and will not be considered for further evaluation.
- 1.6 The validity of this MOU is for TWO years from the date of signing. After the expiry of the period, the same can be extended further with or without any modifications. However, in case any improvements are required, the MOU may be amended before the expiry of the validity.

VENDOR  
 Signature :  
 Date : 28/11/08  
 Company seal :  
**ENVIRONNEMENT S A.**  
 111 Bd Robespierre,  
 78300 POISSY  
 Tel : 01 39 65 38 00  
 Fax : 01 39 65 38 00

ENGINEERING  
*D. Jayanthi*  
**D. JAYANTHEE**  
 Manager  
 E, C & I / FBC & HRSG  
 BHEL, Tiruchirappalli - 620 014.

PURCHASE  
*N. Subramanian*  
**N. SUBRAMANIAN**  
 MANAGER  
 PURCHASE / FBC & HRSG  
 BHEL TIRUCHIRAPPALLI 620 014.



MEMORANDUM OF UNDERSTANDING FOR SO<sub>2</sub>, NO<sub>x</sub>, CO & CO<sub>2</sub> ANALYSER

MOU / TPFH / SO<sub>2</sub>, NO<sub>x</sub>, CO & CO<sub>2</sub> ANALYSER  
REV: 00

Date : 10-11-2008  
Page: 3 of 9

- 1.7 Free commissioning spares (if applicable) with price break up as per the list (vide Section 5.0) shall be supplied along with SO<sub>2</sub>, NO<sub>x</sub>, CO & CO<sub>2</sub> analyser.
- 1.8 Two years recommended Spares list with price break up (vide Section 5.0) shall be enclosed along with vendors offer.
- 1.9 If any special or non-standard tools are required for installation, operation or maintenance, the same shall be supplied along with the Analyser. The same shall be as part of main supply.
- 1.10 The equipment shall be guaranteed for a period of 18 months from the date of commissioning or 24 months from the date of dispatch, whichever is earlier.
- 1.11 Vendor has to provide Bank Guarantee for 10% order value (as per BHEL format) valid for a period mentioned in point No.1.10.
- 1.12 Despatch clearance will be issued along with PGMA with DU Nos. for the ordered items to vendor after the receipt of acceptable Inspection Report. Vendor agreed to mark the PGMA with DU Nos. in the casing of the packing and in the Packing Slip.
- 1.13 Materials shall be dispatched on "Door Delivery with or without Consignee Copy attached basis to avoid damage at transporter's godown".
- 1.14 Since the vendors works alone is approved by BHEL, it is agreed the vendor will manufacture this item in their own works only and will not off-load the jobs to any other suppliers without the written approval by BHEL.
- 1.15 All components should be packed in such a way that it should not get damaged during transport.
- 1.16 BHEL and the Vendor shall have an involvement which will commence at bid stage and follow through the completion and acceptance, thus ensuring total conformity to Purchaser's requirements.

**SECTION 2.0 : SPECIFICATION FOR SO<sub>2</sub>, NO<sub>x</sub>, CO & CO<sub>2</sub> GAS ANALYSER SYSTEM**

SL.NO	SPECIFICATION	BHEL REQUIREMENT
2.1.0	<b>SITE CONDITIONS:</b>	
2.1.1	Ambient Temperature	Refer project data sheet (section 5)
2.1.2	Altitude	500 Mtr Above Mean Sea Level
2.1.3	Applicable Std	As per EPA USA requirement.
2.2.0	<b>CHIMNEY DIMENSION:</b>	
2.2.1	Tapping Detail	As per drg no: 4-97-400-81627 Rev:00

VENDOR  
 Signature :  
 Date : 28/11/08  
 Company seal :

ENGINEERING  
*D. Jayantree*

PURCHASE  
*[Signature]*

**ENVIRONNEMENT S A.**  
 111, Bd. Robert Schuman,  
 78000 BOISSY  
 Tel 01 39 22 38 00  
 Fax 01 39 65 38 08

**D. JAYANTREE**  
 Manager  
 E. C & I / FBC & HRSG  
 BHEL, Tiruchirappalli - 620 014.

**N. SUBRAMANIAN**  
 MANAGER  
 PURCHASE / FBC & HRSG  
 BHEL TIRUCHIRAPPALLI 620 014



**MEMORANDUM OF UNDERSTANDING FOR SO<sub>2</sub>, NO<sub>x</sub>, CO & CO<sub>2</sub> ANALYSER**

MOU / TPFH / SO<sub>2</sub>, NO<sub>x</sub>, CO & CO<sub>2</sub> ANALYSER  
REV: 00

Date: 10-11-2008  
Page: 4 of 9

<b>2.3.0</b>	<b>SCOPE OF VENDOR</b>	
2.3.1	Main Offer	Dilution type SO <sub>2</sub> , NO <sub>x</sub> , CO & CO <sub>2</sub> analyser
<b>2.4.0</b>	<b>SAMPLE PROBE:</b>	
2.4.1	Material	SS 316 suitable for Process & Temp. conditions.
2.4.2	Primary Filter	Required
2.4.3	Probe Length	1500 mm
2.4.4	Probe Mounting	Flanged mounting as per drg no: 4-97-400-81627 Rev.00. The counter flange with gasket to be supplied.
<b>2.5.0</b>	<b>Distance between Probe &amp; Analyser</b>	150 Mtr (approx.) (Unit price of Umbilical tubing to be furnished)
<b>2.6.0</b>	<b>SHS COMPONENTS of the DILUTION MODULE</b>	Shall be with the following minimum: Necessary sample probe, sample cooler, pressure reducing station, dryer, orifice (with standing temp. of 600°C), valves, filters, integral digital indicator, flow indicator etc. required to make the system complete. Tubings and fittings between analyser panel and calibration gas cylinders (10 metres). (Any other hardware, required for successful functioning of the total system, shall be included. Make and model of each component shall be subject to BHEL's approval after order placement).
2.6.1	Dilution ratio	100:1
2.6.2	Dilution accuracy	+/- 2%
2.7.0	Instrument air supply	3.5 to 6 kg/cm <sup>2</sup>
2.7.1	Instrument air requirement	Vendor to specify
<b>2.8.0</b>	<b>ANALYSER PANEL</b>	
2.8.1	Degree of protection	Analyser shall be housed in a free standing panel. The analyser panel shall be IP31.
2.8.2	Construction	The panel shall be with following minimum: Free standing with ISMC 100 base channel & 15mm anti-vibration pad. 2mm CRCA sheet steel fabricated. Double door (Back and Front) with car type lock and key. In addition pad locking facility with pad lock and key shall be provided. Glass window fitted with neoprene gasket. Anti corrosive epoxy based powder coated painting after adequate sand blasting, seven tank process and primer.

VENDOR  
Signature : \_\_\_\_\_  
Date : 28/11/08  
Company seal :

ENGINEERING  
*D. Jayanthee*

PURCHASE  
*N. Subramanian*

**D. JAYANTHIE**  
Manager  
E. C & I / FBC & HRSG  
BHEL, Tiruchirappalli - 620 014.

**ENVIRONNEMENT S A**  
111, Rue de la pierre,  
78300 FOISSY  
Tel 01 39 22 38 00  
Fax 01 39 65 38 08

**N. SUBRAMANIAN**  
MANAGER  
PURCHASE / FBC & HRSG  
BHEL TIRUCHIRAPPALLI 620 014.



MEMORANDUM OF UNDERSTANDING FOR SO<sub>2</sub>, NO<sub>x</sub>, CO & CO<sub>2</sub> ANALYSER

MOU / TPFH / SO<sub>2</sub>, NO<sub>x</sub>, CO & CO<sub>2</sub> ANALYSER  
REV: 00

Date: 10-11-2008  
Page: 5 of 9

2.8.3	Painting	Exterior: Siemens Grey RAL 7032 Interior: Brilliant White
2.8.4	Power Supply	110V AC $\pm 10\%$ , Ph, 50Hz $\pm 3\%$ , UPS Power supply at one point by BHEL. All other distribution within the panel shall be by the vendor. Battery back-up shall be provided for the volatile memory.
2.8.5	Cabling	Screened cable for signal connection. Power and signal cables bundled in separate cable ducts.
2.9.0	<b>APPLICATION:</b>	
2.9.1	SO <sub>2</sub> , NO <sub>x</sub> , CO & CO <sub>2</sub> Analyser (common probe with separate analyser)	To monitor SO <sub>2</sub> , NO <sub>x</sub> , CO & CO <sub>2</sub> in flue gas continuously using Dilution system method.
2.10.0	<b>PRINCIPLE OF ANALYSIS:</b>	
2.10.1	SO <sub>2</sub>	UV
2.10.2	NO <sub>x</sub>	Chemiluminescence
2.10.3	CO	Refer project data sheet (section 5)
2.10.4	CO <sub>2</sub>	Refer project data sheet (section 5)
2.11.0	<b>RANGE:</b>	
2.11.1	SO <sub>2</sub>	0-100 ppm Vol. Dry
2.11.2	NO <sub>x</sub>	0-100 ppm Vol. Dry
2.11.3	CO	0-50 ppm Vol. Dry
2.11.4	CO <sub>2</sub>	0-15% Vol. Dry
2.12.0	OUTPUT:	One separate isolated 4 - 20mA, 2 wire 24V DC corresponding to the selected range to be provided for external load (max 500 ohms) for each element.
2.13.0	Accuracy	Less than $\pm 2\%$ of Span
2.14.0	Sensitivity	$\pm 0.5\%$ of Span
2.15.0	Reproducibility	$\pm 1\%$ of Span
2.16.0	Response time including Dead band (90% value)	Better than 150 sec.
2.17.0	Zero drift	2% if full scale value / week
2.18.0	Linearity error	% of 2 % of the span
2.19.0	Temperature effect per 10 <sup>0</sup> C	$\leq \pm 2\%$ of span
2.20.0	Signal processing	With microprocessor electronic circuitry.
2.21.0	Alarm contact	Two set points one for high alarm and one for low alarm for each element. The relays shall have 2 SPCO contacts. Contact rating shall be 5A at 240V

VENDOR  
Signature :  
Date : 28/11/08  
Company seal :

**ENVIRONNEMENT S.A.**  
111 Bd Robespierre,  
~~Tel 01 39 22 38 00~~  
Tel 01 39 22 38 00  
Fax 01 39 65 38 00

ENGINEERING  
*D. Jayanthee*  
**D. JAYANTHEE**  
Manager  
E. C & I / FBC & HRSG  
BHEL, Tiruchirappalli - 620 014.

PURCHASE  
*N. Subramanian*  
**N. SUBRAMANIAN**  
MANAGER  
PURCHASE / FBC & HRSG  
BHEL TIRUCHIRAPPALLI 620 014.



**MEMORANDUM OF UNDERSTANDING FOR SO<sub>2</sub>, NO<sub>x</sub>, CO & CO<sub>2</sub> ANALYSER**

MOU / TPFH / SO<sub>2</sub>, NO<sub>x</sub>, CO & CO<sub>2</sub> ANALYSER  
REV: 00

Date: 10-11-2008  
Page: 6 of 9

		AC.
2.22.0	Span & Zero check	Manual by integral electronics for zero and span adjustment.
2.23.0	<b>Calibration:</b>	
2.23.1	Type	Auto calibration system shall be offered along with all hardware and software. A write-up on Auto calibration feature shall be elaborately furnished in the offer.
2.23.2	Gas cylinder	Aluminium Gas cylinders with industrial S. pressure regulator and pressure gauge for - Span gas (SO <sub>2</sub> , NO <sub>x</sub> , CO & CO <sub>2</sub> ) - Zero gas - Any other calibration gas cylinder if required for the system offer.
2.23.3	Scope of Supply	1. Scope of supply shall include carrier gas, calibration sample cylinders for zero as well as span calibration of each analyser for a period of one year after the system acceptance. For sample blends which deteriorates may have deferred delivery of the cylinder. 2. During calibration, the deviations of actual calibration from the calibration curve supplied by vendor shall be within $\pm 10\%$ of the specified value. If deviations within $\pm 10\%$ are not achieved at site, then necessary modification to the analyser system shall be done by vendor without any cost implication.
		3. All analysers shall be calibrated using a test sample showing 50% of scale reading for the component of interest. Deviation of actual calibration curve supplied by vendor shall be within $\pm 1\%$ of span. 4. Repeatability shall be demonstrated for a period of at least 8 hours continuously using a standard sample. For infra-red/ ultra-violet analysers, the preparation of components in the test sample shall be changed to confirm the absence of / interference from components other than components of interest.
2.24.0	Location of Analyser Panel	In Air Conditioned analyser room
2.25.0	<b>Commissioning</b>	
2.25.1	Vendor scope	Separate lump sum price for commissioning shall be

VENDOR  
Signature :  
Date : 28/11/08  
Company seal :

ENGINEERING  
*D. Jayanthi*

PURCHASE  
*[Signature]*

**ENVIRONNEMENT S A.**  
111 Bd Robespierre,  
93000 BOISSY  
Tel 01 39 22 38 00  
Fax 01 39 65 38 08

**D. JAYANTHIE**  
Manager  
E. C & I / FBC & HRSG  
BHEL, Tiruchirappalli - 620 014.

**N. SUBRAMANIAN**  
MANAGER  
PURCHASE / FBC & HRSG  
BHEL TIRUCHIRAPPALLI 620 014.



MEMORANDUM OF UNDERSTANDING FOR SO2, NOx, CO & CO2 ANALYSER

5/8

MOU / TPFH / SO2, NOx, CO & CO2 ANALYSER  
REV: 00

Date: 10-11-2008  
Page: 7 of 9

		furnished in the price bid.
2.25.2	Commissioning spares	Vendor shall bring the required commissioning spares during commissioning at site.
2.25.3	Commissioning Protocol	Vendor shall be responsible for establishing the successful performance of analysers up to one year from date of commissioning and making firm protocol with ultimate customer.
<b>2.26.0</b>	<b>Documents</b>	
2.26.1	Along with the offer	<p>Three copies of following documents shall be supplied by the vendor.</p> <ol style="list-style-type: none"> <li>1. Technical leaflets of the analyser</li> <li>2. BOM with unit price for all applicable accessories like purging unit, thermocouple, probe, calibration gas cell &amp; any other required accessories.</li> <li>3. Consumable like electric power and instrument air requirement.</li> <li>4. Heat dissipation from analyser system including SHS.</li> <li>5. Any special control &amp; interlock requirement with schematics.</li> <li>6. Sampling system P&amp;ID with auto-calibration configuration.</li> <li>7. Panel GA with overall dimension &amp; with BOM.</li> <li>8. Commissioning offer including commissioning spares.</li> <li>9. Split up prices for gas cylinders.</li> <li>10. O&amp;M spares / mandatory spares for two years trouble free operation.</li> <li>11. Total weight of the system with break-up.</li> </ol>
2.26.2	After ordering: (Within one month from the date of LOI):	<p>Six sets of the following for BHEL's approval before manufacturing is started</p> <ol style="list-style-type: none"> <li>1. P &amp; ID of Analyser system with scope and terminal point details.</li> <li>2. Pipe connection &amp; SHS</li> <li>3. GA with internal arrangement and foundation details for the panel.</li> <li>4. Panel wiring diagram.</li> <li>5. Specification and data sheet for SHS component and analyser proper, BOM.</li> <li>6. Interconnection wiring drg. with cabling details.</li> <li>7. List of despatchable components in line with the packing slip.</li> <li>8. Recommended storage and preservation</li> </ol>

VENDOR  
Signature :  
Date : 28/11/08  
Company seal :  
**ENVIRONNEMENT S.A.**  
111 Bd Robespierre,  
TIRUCHIRAPPALLI  
Tel 01 39 22 38 00  
Fax 01 39 65 38 08

ENGINEERING  
*D. Jayanthie*  
**D. JAYANTHIE**  
Manager  
E, C & I / FBC & HRSG  
BHEL, Tiruchirappalli - 620 014.

PURCHASE  
*[Signature]*  
**N. SUBRAMANIAN**  
MANAGER  
PURCHASE / FBC & HRSG  
BHEL TIRUCHIRAPPALLI 620 014.



MEMORANDUM OF UNDERSTANDING FOR SO<sub>2</sub>, NO<sub>x</sub>, CO & CO<sub>2</sub> ANALYSER

MOU / TPFH / SO<sub>2</sub>, NO<sub>x</sub>, CO & CO<sub>2</sub> ANALYSER  
REV: 00

Date: 10-11-2008  
Page: 8 of 9

2.76.3.	Before despatch	<p>procedure.</p> <p><b>5 sets of the following final documents :</b></p> <ol style="list-style-type: none"> <li>1. P &amp; ID of Analyser system with scope and terminal point details.</li> <li>2. Pipe connections &amp; sample handling system.</li> <li>3. GA with internal arrangement and foundation details for the analyser panel.</li> <li>4. Panel wiring diagram</li> <li>5. Specification and datasheet for each of the SHS component and analyser proper, BOM</li> <li>6. Interconnection wiring diag with cabling details.</li> <li>7. Calibration / Trouble shooting procedure.</li> <li>8. Method of grounding</li> <li>9. Test and calibration.</li> <li>10. Certificates of the analyser and SHS components.</li> <li>11. Type test certificates from National bodies (3 copies only).</li> <li>12. O&amp; M Manuals – 3 sets should contain detailed write up on the system operation and</li> </ol> <p>Instructions shall be made available for periodic and preventive maintenance. O&amp;M manual in electronic form (PDF Format) – 2 sets</p>
---------	-----------------	---

Section – 3.0 Testing, Inspection and Packing.

3.1.	Testing And Inspection	Vendor to submit their QP for BHEL's approval. The total system is subject to BHEL and ultimate customers inspection at vendors works.
3.2.	Packing	Analyser components shall be packed in a thermocole box. Such box shall be placed in a carton / metal case with adequate cushioning material to withstand sea / air transit risks. Mounted components shall be provided with additional support to take care of transit and handling risks.
3.3	Protocol	Vendor is responsible for establishing the successful performance of the analyser up to one year from the date of commissioning and making firm protocol with ultimate customer

VENDOR  
 Signature: \_\_\_\_\_  
 Date: 28/11/08  
 Company seal:  
**ENVIRONNEMENT S.A.**  
 111 Bd Robespierre,  
 12900 BRISSY  
 Tel 01 39 22 38 00  
 Fax 01 39 65 38 08

ENGINEERING  
*D. Jayanthee*  
**D. JAYANTHEE**  
 Manager  
 E. C & I / FBC & HRSG  
 BHEL, Tiruchirappalli - 620 014.

PURCHASE  
*N. Subramanian*  
**N. SUBRAMANIAN**  
 MANAGER  
 PURCHASE / FBC & HRSG  
 BHEL TIRUCHIRAPPALLI 620 014.



MEMORANDUM OF UNDERSTANDING FOR SO2, NOx, CO & CO2 ANALYSER

MOU / TPFH / SO2, NOx, CO & CO2 ANALYSER  
REV: 00

Date: 10-11-2008  
Page: 9 of 9

**SECTION 4.0 - DATA SHEET / Documents shall be submitted along with their offer.  
Offer will be rejected, if this details are not available with the offer.**

	BHEL Requirement for evaluation of Offer	Confirmation YES / NO
4.1	Confirmation for supplying materials as per the Section 5, Project Data Sheet	YES
4.2	Confirmation for supplying materials as per the MOU, ref: MOU / TPFH / SWAS	YES
4.3	Quality Plan enclosed along with the Offer	YES
4.4	Documents submitted along with the offer as per Cl. 2.26.1	YES
4.5	Acceptance for document submission as per Cl. 2.26.2	YES
4.6	Acceptance for document submission as per Cl. 2.26.3	YES
4.7	Confirmation for no deviation	CONFIRM
4.8	If deviation taken, list of deviation enclosed along with the Offer	NO DEVIATION

*[Signature]*  
 Signature :  
 Date :  
 Company :  
**ENVIRONNEMENT S.A.**  
 111 Bd Robespierre,  
 78300 POISSY  
 Tel 01 39 22 38 00  
 Fax 01 39 65 38 08

ENGINEERING  
*[Signature]*  
**D. JAYANTHEE**  
 Manager  
 E. C & I / FBC & HRSG  
 BHEL, Tiruchirappalli - 620 014.

PURCHASE  
*[Signature]*  
**N. SUBRAMANIAN**  
 MANAGER  
 PURCHASE / FBC & HRSG  
 BHEL TIRUCHIRAPPALLI 620 014.

**PROJECT DATA SHEET FOR SO<sub>2</sub>, NO<sub>x</sub>, CO ANALYSER**

SLNO	SPECIFICATION	BHEL REQUIREMENT	VENDOR CONFIRMATION YES / NO
<b>1.0</b>	<b>SITE CONDITIONS:</b>		
1.1	Ambient Temperature	5.6 to 47° C	
1.2	Altitude	7.1 Mtr Above Mean Sea Level	
<b>2.0</b>	<b>FLUE GAS PARAMETERS:</b>		
2.1	Pressure	30 mmwc	
2.2	Temperature	175° C	
2.3	Applicable Std	As per EPA USA requirement (or) TUV approved.	
<b>3.0</b>	<b>CHIMNEY DIMENSION:</b>		
3.1	Diameter	3500 mm	
3.2	Wall thickness	Will be furnished during ordering	
3.3	Height	80 Mtrs	
3.4	Location of Tapping	75 Mtrs from ground	
3.5	Tapping Detail	As per BHEL drg no: 4-97-400-82883	
<b>4.0</b>	<b>SCOPE OF VENDOR:</b>		
4.1	Main Offer	Dilution type SO <sub>2</sub> , NO <sub>x</sub> & CO Analyser Optical bench and Transmitter with Probe and Sample Handling System.	
<b>5.0</b>	<b>SAMPLE PROBE:</b>		
5.1	Probe Mounting	Flanged mounting as per drg no: 4-97 -400 -82883. The counter flange with gasket & fasteners are to be supplied by the vendor.	
6.0	Dilution ratio	100:1 (or) vendor to specify	
7.0	Instrument air requirement	<b>Vendor to specify</b>	
8.0	Distance between probe & Analyzer	180 Mtr for HRSG#1 and 3 150 Mtr for HRSG#2 and 4 (Unit price of Umbilical tubing to be furnished)	
<b>9.0</b>	<b>ANALYSER PANEL:</b>		
9.1	Degree of protection	Analyser shall be housed in a free standing panel. The analyser panel shall be IP54.	
9.2	Painting	Siemens Grey RAL 7035 (Both inside & Outside)	

**PROJECT DATA SHEET FOR SO<sub>2</sub>, NO<sub>x</sub>, CO ANALYSER**

SLNO	SPECIFICATION	BHEL REQUIREMENT	VENDOR CONFIRMATION YES / NO
9.3	Construction	The panel shall be with following minimum: Free standing with ISMC 100 base channel & 15mm anti-vibration pad. 3mm CRCA sheet steel fabricated. Double door (Back and Front) with car type lock and key. In addition to pad locking facility with pad lock and key shall be provided. Glass window fitted with neoprene gasket. Anti corrosive epoxy based powder coated painting after adequate sand blasting, seven tank process and primer.	
9.4	Power Supply	110V AC $\pm$ 10%, 1Ph, 50Hz $\pm$ 3%, UPS Power supply at one point by BHEL. All other distribution within the panel shall be by the vendor. Battery back-up shall be provided for the volatile memory.	
10.0 10.1	<b>APPLICATION :</b> SO <sub>2</sub> , NO <sub>x</sub> , CO Analyser (common probe with separate analyser)	To monitor SO <sub>2</sub> , NO <sub>x</sub> , CO in flue gas continuously using Dilution system method.	
11.0 11.1	<b>PRINCIPLE OF ANALYSIS:</b> SO <sub>2</sub> NO <sub>x</sub> CO	UV Chemiluminescence NDIR/ Gas filter correlation	
12.0 12.1	<b>RANGE:</b> SO <sub>2</sub>  NO <sub>x</sub>  CO	0-25, 0-50, 0-100 ppm Vol. wet (Selectable) 0-200, 0-500 ppm Vol. dry @ 15% O <sub>2</sub> (Selectable) 0-200, 0-500 ppm Vol. wet (Selectable)	
13.0	OUTPUT	One separate isolated 4 - 20mA, 2 wire 24V DC corresponding to the selected range to be provided for external load (max 500 ohms) for each element. RS485 modbus link to DCS.	

**PROJECT DATA SHEET FOR SO<sub>2</sub>, NO<sub>x</sub>, CO ANALYSER**

SLNO	SPECIFICATION	BHEL REQUIREMENT	VENDOR CONFIRMATION YES / NO
14.0	Span & Zero check	Automatic periodic with manual over ride using optical filters mounted inside. Test certificates for these filters shall be provided (or) <b>Source light switch off / modulate the intensity.</b>	
15.0	Gas cylinder	i) Aluminium Gas cylinders minimum 10 ltr with industrial SS pressure regulator and both inlet and outlet pressure gauge for - Span gas (SO <sub>2</sub> , NO <sub>x</sub> , CO) -Instrument air to be used instead of zero gas -Any other calibration gas cylinder if required for the system offered.  ii) Gas cylinders are to be despatched to site one week prior to system calibration and commissioning  iii) Explosive certificates for Calibration Gas Cylinders.	
16.0	Proven track record list	Proven track record for the system (with all its sub-systems) as being offered / supplied should have been installed and operating satisfactorily in a captive power plant application / hydrocarbon industry like Refinery, Petrochemical or Gas Processing Plant for at least 4000 hrs (as collaborated by user certificate).	
17.0	Training	Required. Min. 3 days at site	

**PROJECT DATA SHEET FOR SO<sub>2</sub>, NO<sub>x</sub>, CO ANALYSER**

SLNO	SPECIFICATION	BHEL REQUIREMENT	VENDOR CONFIRMATION YES / NO
18.0	<p><b>POST WARRANTY MAINTENANCE FOR SYSTEMS (min. 10 years)</b></p> <p>a) In the event of any malfunction of the system hardware/ system software, experienced service engineer shall be made available at site within 24 hours on the receipt of such information from owner.</p> <p>b) The contract shall include detailed proposal related to supply of maintenance spares, tools and tackles as required, travel, boarding and lodging of service engineer to site on short notice.</p> <p>c) Contractor after completion of warranty shall transfer the contract of system vendor to owner for direct interaction between owner and system vendor.</p> <p>d) The services under Post Warranty Maintenance Contract including supply of spare parts and services shall broadly encompass the following:</p> <ul style="list-style-type: none"> <li>- Preventive Maintenance Once in a year, involving complete overhaul of the system, inspection of hardware and software, fault prediction, inspection of power supply quality, environmental and operating condition checks, calibration checks, major repairs/replacements and detailed reporting.</li> <li>- Periodic Maintenance Site visits, minimum four-six times in a year, inspection of general healthiness of the system, study and advice on daily maintenance, inspection of hardware and software, if any problem is reported, running of test programmes, on-line servicing and solving reported problems. Checks shall be conducted on running system i.e (a) On-line subsystems, (b) Power supply checks, (c) TFT, (d) printer, (e) Any Other vendor recommended service. Complete scope of work involved under each category must be outlined by the system vendor.</li> <li>- Software maintenance Maintain existing software to improve and utilise existing application and improve performance of the system. Minor modification of the software shall also be covered under this scope.</li> <li>- Emergency Service Any failure shall be on system suppliers account. The Engineer must report at site within 24 hours of report of failure, with necessary spares. The system must be brought back within 24 hours after reporting at site.</li> <li>- Software Updates All future updates on system hardware/software provided shall be made available to owner as and when available. The installation charges as applicable shall be included.</li> </ul>		

**PREPARED**

*Ahmed S.*

**CHECKED**

*D. Kavitha*

**APPROVED**

*[Signature]*

**ANNEXURE- 1**

**LOGISTIC SUPPORT**

**Certificate For Logistics Support (by Principal)**

(To be signed by Principal's corporate level signatory on company's letterhead)

I, on behalf of M/s \_\_\_\_\_ confirm that the analyser quoted by M/s \_\_\_\_\_ for Steam and Power Generation Plant of OPaL Project shall continue to be supported by us. The quoted item shall not be withdrawn from Indian market as a matter of our corporate policy.

I further confirm that in case of placement of order by OPaL on M/s \_\_\_\_\_ we shall continue to support M/s \_\_\_\_\_ in providing back-up engineering, maintenance support and spare part to OPaL for a period of 10 years from the date of placement of order.

SIGNATURE WITH SEAL  
AUTHORIZED, SENIOR MANAGEMENT LEVEL

**Certificate For Logistics Support (by vendor)**

(To be signed by Vendor's corporate level signatory on company's letterhead)

I, on behalf of M/s \_\_\_\_\_ confirm that the analyser quoted by M/s \_\_\_\_\_ for Steam and Power Generation Plant of OPaL Project shall continue to be supported by us and our principal(s). The quoted item shall not be withdrawn from Indian market as a matter of our corporate policy as supported by attached certificate from our principal(s) M/s \_\_\_\_\_.

I further confirm that in case of placement of order by OPaL on us, we shall continue to support OPaL in providing back-up engineering, maintenance support and spare part to OPaL for a period of 10 years from the date of placement of order.

SIGNATURE WITH SEAL  
AUTHORIZED, SENIOR MANAGEMENT LEVEL  
SIGNATORY

CAUTION: THE INFORMATION ON THIS DOCUMENT IS THE PROPERTY OF BHEL  
IT MUST NOT BE USED DIRECTLY OR INDIRECTLY  
IN ANY WAY DEEMED TO BE IN THE INTEREST OF THE COMPANY

ANALYSER POCKET ARRANGEMENT

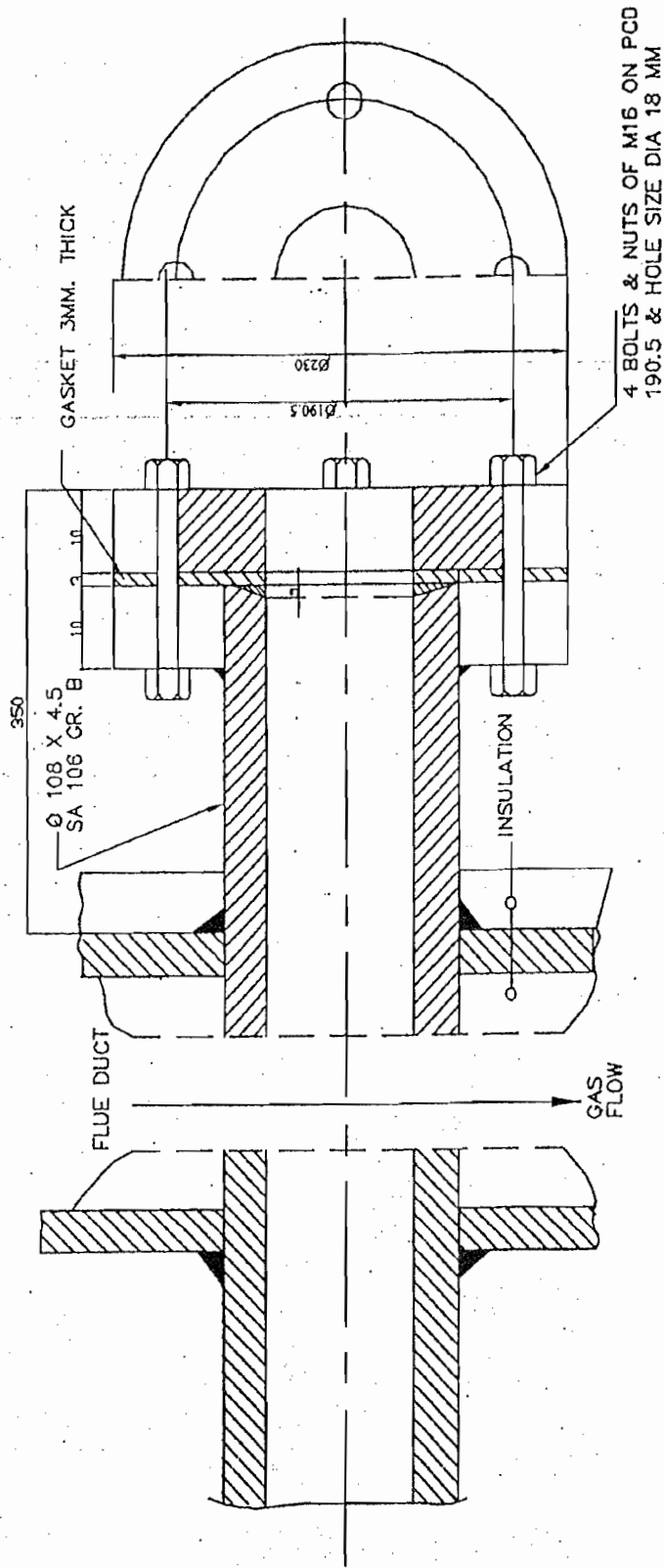

NAME P.V.KANTOR		SIGNATURE -S/-		DATE 23.12.2004		BHEL		CUST.NO	
CHD P.V.KANTOR		-S/-		23.12.2004		361 401		BHARAT HEAVY ELECTRICALS LIMITED	
APPD K.S.KANTOR		-S/-		23.12.2004		ELEC. C & I		FBC & HRSG	
FILE NAME 49782833.DWG		DCPT 361 401		CODE 3611		ELEC. C & I		TIRUCHIRAPPALLI - 620014	
FLOPPY NO		ELEC. C & I		DCPT 361 401		ELEC. C & I		PROJECT STANDARD	
TITLE TAPPING DETAILS FOR FLUE GAS ANALYSERS		ELEC. C & I		DCPT 361 401		ELEC. C & I		DRAWING NO : 4-97-400-82883	
CUSTOMER: CONSULTANT:		ELEC. C & I		DCPT 361 401		ELEC. C & I		SHEET NO	
DRAWING NO : 4-97-400-82883		ELEC. C & I		DCPT 361 401		ELEC. C & I		REV - 02	

**PROJECT: M/S OPAL  
ANNEXURE TO SPECIFICATION FOR GAS ANALYSER**

REF:FBC&HRSG:CI:OPAL:GASANAL  
REV:00

DATE:7-2-11

IN THE EVENT OF INCONSISTENCY OR AMBIGUITY BETWEEN THE TDC  
SPECIFICATION AND THIS ANNEXURE, THE LATTER WILL TAKE PRECEDENCE.

ORDER OF PRECEDENCE SR NO 1 -> SR NO 2-> SR NO-> 3

SL.NO.	REQUIREMENT	VENDOR COMPLIANCE
01	<p>i) ANALYSER SHELTER / ROOM The analyser system for flue gas analysis and other analysers shall be interfaced with DCS using dual redundant RS485 MODBUS link. Hardwired signals shall be considered for analysers providing 4~ 20 mA signals which shall be directly connected to the respective section of DCS.</p> <p>The location of Analyzer shelter for stack monitoring system and analyzer room for other analysers shall be in safe area and exact location shall be decided based on: -</p> <ul style="list-style-type: none"> <li>i) Allowable transportation time for each sample point.</li> <li>ii) Available space requirement for analyzer shelter/ room.</li> <li>iii) Accessibility with respect to approaches &amp; obstructions.</li> <li>iv) Space required for equipment maintenance and calibration</li> </ul> <p>In no case, the transportation time should exceed the recommended figures indicated in the Process package. In case no value is indicated the transportation time should be considered less than one minute. For the purpose of analyser shelter sizing Contractor shall consider the minimum width of 3000 mm and 2500 mm height .The length should be decided based on factors indicated above.</p> <p>g) All analyzers shall be micro-processor based in general and shall be capable of providing detail diagnostic alarms, messages to help maintenance personnel.</p> <p>An Analyser control system shall be provided in the unit, linking together by a network, all analyser systems and Gas Chromatographs. This network of analysers shall form the Analyser Data Management System for the unit. The network shall include an operator interface in the control room for the unit and an interface to DCS.</p>	

REF: FBC &amp; HRSG: CI: OPAL: GABANAL

REV: 00

	<p>The Analyser Data Management System shall also have interface with LIMS (Laboratory Information Management System) provided by others. LIMS is a separate control system which interfaces with DCS and a network of analysers gas chromatographs, mass spectrometers etc. in the plant and is designed to collect real time data and to produce an output in order to meet the business</p> <p>Flue gas monitoring system shall be used for continuous emission of stack and heaters. SOx, NOx, , and CO analysers are required for stack. SOx/NOx/CO: Dilution type to meet the required specification and performance unless otherwise specified in job specification.</p> <p>Probe shall be provided with necessary filter and material suitable for the temperature and process condition. The dilution shall take place near the probe where dilution type is specified.</p> <p>9.2.2 Sample tubing Minimum SS for dilution type. Teflon tube electrically heat traced and armoured for extraction type. Automatic temperature control shall be provided for the tubes.</p> <p>9.2.3 Sample conditioning Pressure reduction, heating/cooling flow meters etc along with other system components as per API and as recommended by vendor. Provision of first loop, condensate knock off shall be provided.</p> <p>9.2.4 Analyzers Analyzers shall be electronic microprocessor based with full diagnostic facility. The analysers shall be located in prefabricated shelter.</p> <p>9.2.5 Analyzer shelter</p> <ol style="list-style-type: none"> <li>i) The flue gas analyzers shall be located in a prefabricated analyser shelter, which shall be placed in safe area.</li> <li>ii) External side walls and internal side walls shall be adequately strong 2 mm SS sheet. The design and construction of the shelter shall be as per 6987-6-52-0053.</li> <li>iii) The shelter roof shall be adequately strong and sealed to prevent entry of rain and jet water.</li> <li>iv) The shelter shall be provided with main door and an emergency door opposite to main door. Both doors shall be opening outwards,</li> </ol>	
--	---	--

REF: FBC & HRSG : CI : OPAL : GAS ANAL

REV: 00

	<p>provided with safety glass window and automatic spring door closer.</p> <p>v) Extension roof provided along the two longer sides shall be hanged at least 1000 mm outside the analyser shelter.</p> <p>vi) The tag numbers of analysers shall be fixed near the main door. The tag number of each analyser shall be fixed near the respective items. Inlet/outlet pipes, electrical wires inside the junction box and cables shall be identified.</p> <p>vii) All sample handling system and the fast loop devices shall be kept outside the shelter.</p> <p>viii) Shelter shall be placed in a safe area. Shelter shall be provided with a HVAC System as per specification for Analyzer Shelter attached to keep the inside temperature at 24C +/- 2% with humidity less than 50% to obtain repeatability and reliability of the analysers.</p> <p>ix) LEL detectors shall be installed inside and outside / around shelter with interconnection to DCS.</p> <p>9.2.6 Auto and span control: Contractor shall provide all hardware and software required for auto zero and span calibration.</p> <p>9.2.7 Calibration Gas Cylinder/Consumables All calibration cylinders and other necessary items for analyser calibration shall be supplied by the Contractor, considering the requirement of start up / commissioning plus 1 year normal operation. The cylinders shall be located outside the cabinets and Contractor shall provide suitable mounting accessories for the same. Cylinders shall be supplied in two sets, one shall be used and the other for storage and filling.</p> <p>Flue gas analysers for emission monitoring (i.e. SOx, NOxCO ) shall be TUV approved or it shall be as per EPA, USA regulations. On line stack analyser point to be approachable location at lowest possible height.</p> <p>2. vendor to design &amp; supply common analyzer shelter along with supply of SO2 ,Nox,CO analyzer based on Dilution type. There will be a common panel housing not only SO2 ,Nox ,CO analyzer(one set per boiler) supplied by same shelter vendor but also 1 SPM insitu type electronics(per boiler), 2 NOs O2 insitu type electronics (per boiler)supplied as free items . Mounting the free supplied items are in vendors scope.</p>	
--	--	--

REF : FBC & HRSG : CI : OPAL : GASANAL  
REV : 00

3. Shelter shall be common for both boilers .It will house analysers of 2 boilers .

4. Vendor to supply their quality plan for buyer's approval .

5.Overall dimension of shelter to be indicated positively along with offer.vendor has to furnish GA of analyzer shelter and utility requirements.

**LOGISTIC SUPPORT**

20.1 Logistic support certificate as per format below from the supplier of DCS, PLC, Machine monitoring system, STG, BMS, CCTV, antisurge controllers, all types of analysers and chromatograph shall be provided on part of each purchase specification Certificate. The logistic support certificate shall be signed by a corporate level person of the vendor/  
vendor's principal.

20.2 a) Certificate For Logistics Support (by Principal)  
(To be signed by Principal's corporate level signatory on company's letterhead)

I, on behalf of M/s confirm that the \* quoted by M/s for Steam and Power Generation Plant of OPaL Project shall continue to be supported by us. The quoted item shall not be withdrawn from Indian market as a matter of our corporate policy.

I further confirm that in case of placement of order by OPaL on M/s we shall continue to support M/s in providing back-up engineering, maintenance support and spare part to OPaL for a period of 10 years from the date of placement of order.

SIGNATURE WITH SEAL  
AUTHORIZED, SENIOR MANAGEMENT LEVEL  
\* DCS/ PLC/ Machine monitoring system/ all types of analysers and chromatograph, Steam Turbine Control System, BMS, antisurge controllers, CCTV system and any other Control System provided by Contractor.

20.2 b) Certificate For Logistics Support (by vendor)  
(To be signed by Vendor's corporate level signatory on company's letterhead)

I, on behalf of M/s confirm that the \* quoted by M/s for Steam and Power Generation Plant of OPaL Project shall continue to be supported by us and our principal(s). The quoted item shall not be withdrawn from Indian market as a matter of our corporate policy as supported by attached certificate from our principal(s) M/s .

REF: FBC & HRSG : CI : OPAL : GASANAL

REV: 06

	<p>I further confirm that in case of placement of order by OPaL on us, we shall continue to support OPaL in providing back-up engineering, maintenance support and spare part to OPaL for a period of 10 years from the date of placement of order.  <b>SIGNATURE WITH SEAL</b>  <b>AUTHORIZED, SENIOR MANAGEMENT LEVEL</b>  <b>SIGNATORY</b>          * DCS/PLC/Machine monitoring system/all types of analysers and chromatograph,          Steam Turbine Control System, BMS, antisurge controllers, CCTV system and          any other Control System provided by CONTRACTOR.</p>	
<p>02</p>	<p>All online process analysers shall be supplied with built-in Auto calibration without operator intervention, complete with required calibration apparatus/ calibration gas cylinders etc. Each analyser shall be complete with fault and maintenance contacts to advise analyser status in the DCS. An Analyser control system shall be provided in an unit, linking together by a network, all analyser systems and Gas Chromatographs. This network of analysers shall form the Analyser Data Management System for the unit. The network shall include an operator interface in the Unit control room/ SRR for the unit and an interface to DCS.</p>	
<p>03</p>	<p><b>Standard spec 6987-6-52-0088 Rev.0</b></p>	

PREPARED: *V. Venkatesh*

CHECKED: *[Signature]*

APPROVED: *[Signature]*

**BHARAT HEAVY ELECTRICALS LIMITED  
TRICHY -14**

**FBC & HRSG**

**ELECTRICALS, CONTROLS & INSTRUMENTATION**

<b>MOU/TPFH/SO2, NOX, CO /6011</b>	<b>REV 00</b>	<b>PAGE: 01 OF 03</b>
------------------------------------	---------------	-----------------------

**SPECIFICATION FOR SO2, Nox, CO GAS ANALYSER SYSTEM**

<b>REV NO</b>	<b>DATE</b>	<b>DESCRIPTION</b>	<b>PREPARED</b>	<b>CHECKED</b>	<b>APPROVED</b>
00	7.2.2011	INITIAL ISSUE	VENGAT <i>Vengat</i>	NIKIN <i>Nikin</i>	S.JAYAPRAKASH <i>SJ</i>

**NOTE:**

Vendor to indicate 'YES', 'NO' or 'NOT APPLICABLE' in the confirmations column, duly sign, stamp all pages and furnish along with the offer.

SPECIFICATION FOR SO<sub>2</sub>, No<sub>x</sub>, CO GAS ANALYSER SYSTEM

SL.NO	SPECIFICATION	BHEL REQUIREMENT	VENDOR CONFIRMATION YES / NO
<b>1.0</b>	<b>SITE CONDITIONS</b>		
1.1	Ambient Temperature	46.1	
1.2	Altitude	203.4 Mtr Above Mean Sea Level	
<b>2.0</b>	<b>FLUE GAS PARAMETERS</b>		
2.1	Pressure	300 mmWC	
2.2	Temperature	275° C	
2.3	Applicable Std	As per EPA USA requirement (Or) TUV approved.	
<b>3.0</b>	<b>CHIMNEY DIMENSION</b>		
3.1	Diameter	3500 mm	
3.2	Wall thickness	25 mm	
3.3	Height	35 Mtrs	
3.4	Location of Tapping	19 Mtrs from ground.	
3.5	Tapping Detail	As per BHEL drg no: 4-97-400-82883, Rev:02	
<b>4.0</b>	<b>SCOPE OF VENDOR</b>		
4.1	Main Offer	SO <sub>2</sub> , NO <sub>x</sub> & CO Analyser optical bench and Transmitter with Probe and Sample Handling system.	
<b>5.0</b>	<b>SAMPLE PROBE</b>		
5.1	Probe Mounting	Flanged mounting as per drg no: 4-97-400-82883 Rev: 02. The counter flange with gasket to be supplied.	
<b>6.0</b>	<b>ANALYSER PANEL</b>		
6.1	Degree of protection	Analyser shall be housed in a free standing panel. The analyser panel shall be <b>IP 55</b> .	
6.2	Construction	The panel shall be with following minimum: Free standing with ISMC 100 base channel & 15mm anti-vibration pad. 3mm CRCA sheet steel fabricated. Double door (Back and Front) with car type lock and key. In addition to pad locking facility with pad lock and key shall be	

SPECIFICATION FOR SO2, NOx, CO GAS ANALYSER SYSTEM

		provided. Glass window fitted with neoprene gasket. Anti-corrossive epoxy based powder coated painting after adequate sand blasting, seven tack process and primer.	
<b>7.0</b>	<b>APPLICATION</b>		
7.1	SO <sub>2</sub> , NO <sub>x</sub> , CO Analyser (common probe with separate analyser)	To monitor SO <sub>2</sub> , NO <sub>x</sub> & CO in flue gas continuously using Dilution system method.	
<b>8.0</b>	<b>PRINCIPLE OF ANALYSIS</b>		
8.1	CO	NDIR /Gas filter correlation	
<b>9.0</b>	<b>RANGE</b>		
9.1	SO <sub>2</sub>	0-25,0-50,0-100 ppm ,0-500PPM Vol. Wet (selectable)	
9.2	NO <sub>x</sub>	0-200,0-500 ppm Vol.Dry @ 15% O <sub>2</sub> (selectable)	
9.3	CO	0-50 ppm,0-200PPM,0-500PPM selectable Vol. Dry	
<b>10.0</b>	<b>OUTPUT</b>	One separate isolated 4 - 20mA, 2 wire 24V DC corresponding to the selected range to be provided for external load (max 500 ohms) for each element. Dual redundant RS 485 modbus link to DCS.	
<b>11.0</b>	<b>Span &amp; Zero check</b>	Automatic periodic with manual over ride integral electronics.	
<b>12.0</b>	<b>Proven track record</b>	The system (with all its sub-system) as being offered/supplied should have been installed and operating satisfactorily in a captive power plant application/hydrocarbon industry like Refinery, Petrochemical or Gas Processing plant for atleast 4000 hrs (as collaborated by user certificate).	

