

SUB: Wrench, Key

NIT-Notice Inviting Tender

Salient Details of Notice Inviting Tender (NIT)		
Sl. No.	Issue	Description
1.	Item details	As per Enquiry Annexure <u>L/6431/2022/0554/D1</u>
2.	Issue of Tender Documents	From BHEL eProcurement website https://eprocurebhel.co.in/nicgep/app (Tender documents will be available for downloading from BHEL e-Procurement website till due date of submission)
3.	Due Date Of Offer Submission	Date: 16.07.2022 Time: 13:45 hrs https://eprocurebhel.co.in/nicgep/app Offer to be submitted in online only through e-procurement Portal. (Bidders are requested to visit website to view corrigendum/ addenda/ amendments/ extension/ modification etc. before submitting offer).
4.	Opening of Tender (Techno-Commercial Bid)	Date: 16.07.2022 Time: 14.00 Hrs Notes: <i>This tender being an e-tender, it shall be opened online only through the E-Procurement Portal. Participating bidders may witness the Opening online only.</i>
5.	Cost of Tender	Not applicable
6.	EMD (Earnest Money Deposit)	Nil
7.	Schedule Of Pre-Bid Discussion	Not Applicable
8.	Last Date of Seeking Clarification	Date: 15.07.2022 Time:17.00 Hrs Along with soft version also, addressing to undersigned & to others as per contact address given below. Bidders may consider to seek clarifications on the e-tender portal--- https://eprocurebhel.co.in/nicgep/app
9.	Integrity Pact & Details of Independent External Monitor (IEM)	Not Applicable
10.	Make in India	(i). For this procurement, Public procurement (preference to Make in India), Order 2017 dated 04.06.2020 shall not be applicable .
11.	Restrictions under rule 144 (xi) of General Financial Rule (GFRs) 2017	All provisions of order no F.No.6/18/2019-PPD of department of Expenditure(DoE) shall be applicable for this tender enquiry (Order copy is available at https://doe.gov.in/procurement-policy-divisions). Accordingly, any bidder from a country which

		<p>shares a land border with India (except the countries to which the Gol has extended lines of credit or in which the Gol is engaged in development projects for which list is available at https://www.mea.gov.in/) will be eligible to bid in this tender only if the bidder is registered with the Competent Authority as specified in Annex I of the said Order of DoE.</p> <p>Updated list of the countries to which lines of credit have been extended or in which development projects are undertaken are available on the Ministry of External affairs website (https://www.mea.gov.in/).</p> <p>For the purpose of this order, definition of Bidder from a country which shares a land border with India shall be same as defined in the Annex III of the said order.</p> <p>Registration with the competent authority as stipulated in the said order is responsibility of bidder.</p> <p><u>Bidder has to submit a certificate certifying following along with offer:</u></p> <p><i>“I have read the clause regarding restrictions on procurement from a bidder of a country which shares a land border with India; I certify that bidder (..... Name of Bidder) is not from such a country or, if from such a country, has been registered with the Competent Authority. I hereby certify that bidder (..... Name of bidder) fulfils all requirements in this regard and is eligible to be considered”</i></p> <p>If the bidder is from such country which shares a land border with India evidence of valid registration by the Competent Authority shall also be attached along with offer.</p>
12.	E-Invoice	<p>Vendor Contract clause regarding GST ITC and provision for E-invoices w.e.f. 01.04.2021</p> <p>E-invoicing under GST is being implemented w.e.f. 01.04.2021 for all the taxable persons having turnover more than Rs. 50 Cr. It has been specified by the Govt. that it is mandatory to mention a valid unique Invoice Reference No. (IRN) and QR code as generated from Govt. portal on a Tax Invoice. Based on such information, GST ITC as claimed by BHEL in GST Returns shall be matched with the corresponding details uploaded by supplier in E-invoicing System.</p> <p>In case the vendor /contractor delays or fails to provide all the documents as per the Purchase order / Work Order at the time of submitting Tax invoice to BHEL, any subsequent financial loss to BHEL on account of vendor/contractor shall be to vendor's / contractor's account. BHEL has further right to take necessary steps to protect its interest at the time of release of payment. This further requires inclusion of IRN and QR code on tax invoice as announced by Govt. of India w.e.f. 01.04.2021.</p>

13.	Reverse Auction	Not applicable
14.	Latest Updates	Latest updates on the important dates, Amendments, Correspondences, Corrigenda, Clarifications, Changes, Errata, Modifications, Revisions, etc to Tender Specifications will be hosted in BHEL e-tender portal https://eprocurebhel.co.in/nicgep/app and not in the newspapers. Bidders to keep themselves updated with all such information

Please submit your offer only for the above requirement subject to our **GENERAL INSTRUCTIONS AND STANDARD TERMS & CONDITIONS (GISTC: Version June-21, Rev: 06)**. Please visit our site www.hwr.bhel.com for General Instructions and Standard Terms & Conditions (GISTC) for Tender Enquiries. All the bidders/vendors must ensure compliance of these GISTC. GISTC can also be referred by login to B2B Portal for Registered Vendors.

Tender Fee & EMD –Not Applicable
E-Procurement Portal Inputs

Procedure for Submission of Offer for E – Tender-Procedure for Submission of Tender is available in the “Bidder Manual for BHEL Bidders” at E-tender portal <https://eprocurebhel.co.in/nicgep/app>. Terms and conditions mentioned therein shall form integral part of the NIT and bidders shall abide by the same.

1. Hardware and Software requirements for participating in e-tender

Please refer the website for the minimum system requirements and setting document for Bidders under the link: <https://eprocurebhel.co.in/nicgep/app>

2. Digital Signature

To know the procedure for obtaining Digital Signature Certificate (DSC), suppliers who are not having the DSC are advised to visit our website [http://www.bhel.com/home.php/TenderNotifications/Sample Checklist](http://www.bhel.com/home.php/TenderNotifications/SampleChecklist).

3. NIC portal Helpdesk Contacts

For any technical related queries please call at 24 x 7 Help Desk Number
0120-4001 002
0120-4200 462
0120-4001 005
0120-6277 787
International bidders are requested to prefix 91 as country code

Email Support

Address: A) For any Issues or Clarifications relating to the published tenders, bidders are requested to contact the respective Tender Inviting Authority Technical - support-eproc@nic.in

4. Note

Offers/tenders submitted in the E-tender portal shall only be considered for further evaluation. Offers sent by FAX / E-mail / any mode other than E-tender would not be entertained.

The Tenderers must submit their Tenders, as detailed below:

SPECIAL NOTE: All documents to be submitted should be uploaded in respective places in the E-Tender portal as per the list mentioned given in this NIT. BHEL shall not be responsible for incomplete documents.

For new vendors not registered with us **(Applicable only for open tender)**, kindly furnish copy of following documents:

- Company Name and Address Proof.
- GST Number (Scan Copy of Acknowledgement)
- PAN Copy
- MSME Certificate (UAN, Udyam if Any)

Commercial Term & Condition Compliance

Tender Reference No.	L/6431/2022/0554/D1 Due date: 16.07.2022		
Item Description	Wrench, Key		
Vendor Name			
Quotation Reference no.		Date	

Sl. No.	<u>Techno-Commercial terms</u>	<u>Vendor Confirmation</u>
1.	Please specify whether you are manufacturer or Trader of the item.	
2.	Material will be supplied as per BHEL Specification mentioned in enquiry. Manufacturing, Testing and Certification will be as per ordering specification, if not accepted, then mention deviation.	
3.	Delivery Terms (BHEL Standard term: FOR Destination means CPS/HEEP/ BHEL Haridwar)	
4.	Despatch mode(BHEL Standard term: Through BHEL approved transporter only)	
5.	Origin of Despatch	
6.	Freight Charges ➤ Loading shall be done as per extent rules of BHEL-Haridwar, if Freight is mentioned as 'To Pay'	
7.	Packing Charges ➤ Loading shall be done as per extent rules of BHEL-Haridwar, if Packing charges is 'Extra'	
8.	Forwarding Charges ➤ Loading shall be done as per extent rules of BHEL-Haridwar, if Forwarding charges is 'Extra'.	
9.	Delivery Period in weeks/months (Lead Time from PO date)	
10.	Payment term: "100% payment after receipt & acceptance of material at BHEL HEEP Haridwar".	

	<ul style="list-style-type: none"> ➤ If vendor deviates from BHEL's standard payment term, loading on account of deviation in standard payment term shall be done as per extent rules of BHEL-Haridwar (Refer GISTC) 	
11.	<p>Bank Charges</p> <ul style="list-style-type: none"> ➤ If BHEL's Standard Payment terms accepted then bank charges not applicable, otherwise please mention 	
12.	Rate of GST (CGST/SGST/IGST) extra in % (for Indian Bidder only)	
13.	Test certificate (if applicable) as per Specification shall be provided.	
14.	Guarantee Certificate (if applicable) shall be provided.	
15.	<p>Liquidated Damages (LD) for Late Deliveries shall be applicable @0.5% per week or part thereof on the value of respective delayed supplies subject to maximum of 10% of the value of respective delayed supplies. If vendor do not mention anything about LD clause in their offer, then it shall be presumed to be acceptable. No further clarification shall be asked in this regard after opening of techno-commercial bid part-1.</p> <p>If vendor don't accept this clause, then loading shall be done as per extent rules of BHEL-Haridwar.</p>	
16.	<p>Quotation Validity</p> <ul style="list-style-type: none"> ➤ As per NIT, Validity is 90 days from techno-commercial bid opening date. 	
17.	Currency	
18.	The evaluation currency for this tender shall be INR.	
19.	Are you registered under Micro Small Enterprises (MSE vendor)? if Yes then provide Udyam Certificate (for Indian Bidder only)	
20.	Any other comments (like any other charges, order to be placed on etc.)	
21.	BHEL reserve the right to change the quantity/ Part quantity at the time of ordering.	
22.	Vendor to ensure that their quoted rates are not more than those quoted for any other customer including other BHEL units.	
23.	<p>Vendor to declare that they will not enter into any illegal or undisclosed agreement or understanding, whether formal or informal with other Bidder(s). This applies in particular to prices, specifications, certifications, subsidiary contracts, submission or non-submission of bids or any other actions to restrict competitiveness or to introduce cartelization in the bidding process.</p> <p>In case, the Bidder is found having indulged in above activities, suitable action shall be taken by BHEL as per extant policies/ guidelines.</p>	
24.	Vendor to quote best possible delivery in the offer. Early Delivery acceptable.	
25.	Price bids shall be opened for only those bidders who qualifies PQR and technical specification & whose techno-commercial bid is acceptable to BHEL.	
26.	Remaining terms and conditions shall be as per General instruction and standard terms & conditions (GISTC) version June 21 rev: 06.	
27.	In case of any difference in conditions quoted above & elsewhere in the offer, terms quoted above shall be treated as final and binding on vendor.	

DUEDATE

16-07-2022

SL	MATERIAL CODE ITEM DESCRIPTION	QUANTITY	UNIT	LOTNO	LOT DELIVERY QTY SCHEDULE
1	AA6142100124 WRENCH (SPANNER), OPEN JAW, DOUBLE ENDED (FOR GENERAL PURPOSES) SIZE: 10X11 DIM.: A/F IN MM DIMENSIONS, MARKING AND OTHER REQUIREMENTS: TO CONFORM TO IS:2028-2004. WORKMANSHIP, FINISH, PRESERVATION AND PACKING: TO CONFORM TO IS:6131. MATERIAL: ALLOY STEEL- T50 Cr4 V2 as per IS:3748. HARDNESS: 382 HV (39 HRC),MIN.	15	NO	1	15 15/11/22
2	AA6145100052 KEY FOR HEXAGONAL SOCKET SCREW SIZE: 4.0 DIM.: A/F IN MM DIMENSIONS, TOLERANCES, MATERIAL , HARDNESS, MARKING, PACKING. AND OTHER GENERAL REQUIREMENTS TO CONFORM TO IS:3082-1988 (REAFFIRMED 1998)	35	NO	1	35 15/11/22
3	AA6145100087 KEY FOR HEXAGONAL SOCKET SCREW SIZE: 7.0 DIM.: A/F IN MM DIMENSIONS, TOLERANCES, MATERIAL , HARDNESS, MARKING, PACKING. AND OTHER GENERAL REQUIREMENTS TO CONFORM TO IS:3082-1988 (REAFFIRMED 1998)	20	NO	1	20 15/11/22
4	AA6145100109 KEY FOR HEXAGONAL SOCKET SCREW	20	NO	1	20 15/11/22

SL	MATERIAL CODE ITEM DESCRIPTION	QUANTITY	UNIT	LOTNO	LOT DELIVERY QTY SCHEDULE
----	-----------------------------------	----------	------	-------	------------------------------

SIZE: 10
 DIM.: A/F IN MM
 DIMENSIONS, TOLERANCES, MATERIAL
 , HARDNESS, MARKING, PACKING. AND
 OTHER GENERAL REQUIREMENTS TO
 CONFORM TO IS:3082-1988
 (REAFFIRMED 1998)

5	AA6145200022 ADJUSTABLE WRENCH, SINGLE ENDED OPEN-JAW SIZE: 300 DIM.: WORKING LN GT DIMENSIONS , TOLERANCES, MATERIAL, HARDNESS, MARKING, PACKING AND OTHER GENERAL REQUIREMENTS: TO CONFORM IS:6149-1984 /REAFFIRMED 2000.	10	NO	1	10 15/11/22
---	---	----	----	---	-------------

6	AA6160600028 PLIER-COMBINATION SIDE CUTTING INSULATED SIZE: 200 MM DIMENSIONS, TOLERANCES, MATERIAL HARDNESS, MARKING, PACKING AND OTHER GENERAL REQUIREMENTS : TO CONFORM TO IS:3650. THE HANDLE SHALL HAVE A DURABLE RUBBER OR PLASTIC INSULATION WHICH SHALL WITHSTAND TEST LAID DOWN IN CLAUSE 9.6 OF IS:2615.	25	NO	1	25 15/11/22
---	--	----	----	---	-------------

** IMPORTANT: This enquiry is 2 part tender. Techno-Commercial bid (Part-1) & Price Bids (Part-2) should be submitted in separate envelopes. These two envelopes should be submitted in a common sealed envelope. Techno-Commercial Bid shall contain detailed Technical Specification, Drawings Technical documents, Catalogues, taxes & duties, payment terms, delivery period, Validity of offer, Replica of Price Bid (Copy of price bid without price part) etc. The confirmation to the special terms & conditions must be submitted alongwith Techno-Commercial bid.

Special Instructions:

1. Vendor to quote best possible delivery. Early delivery acceptable.

SL	MATERIAL CODE	QUANTITY	UNIT	LOTNO	LOT DELIVERY QTY SCHEDULE
----	---------------	----------	------	-------	------------------------------

ITEM DESCRIPTION

2.For this procurement, Public procurement (preference to Make in India), Order 2017 dated 15.06.2017,28.05.2018 ,29.05.2019 & 04.06.2020 and subsequent orders issued by the respective nodal ministry shall not be applicable.

3.Rest terms and condition shall be as per latest General Instructions and Standard Terms & Conditions for bidding against Tender Enquiry (GISTC) For Indian Bidders (Version June-2021, Rev: 06).

4.Price bids shall be opened for only those bidders who qualifies PQR and whose techno-commercial bid is acceptable to BHEL.

5.Liquidated Damages (LD) for Late Deliveries shall be applicable @0.5% per week or part thereof on the value of respective delayed supplies subject to maximum of 10% of the value of respective delayed supplies.

If vendor do not mention anything about LD clause in their offer, then it shall be presumed to be acceptable. No further clarification shall be asked in this regard after opening of techno-commercial bid part-1.

SHANKAR TUDU

SR. ENGINEER (PPX-T)

PRE - QUALIFICATION REQUIREMENTS

INDENT 20220554			
01.00	PRE QUALIFYING CONDITIONS	REQUIRED	VENDOR'S OFFER
01.01	<p>For item no 1,5 : Only those vendors to quote who are Original Equipment Manufacturers of WRENCH</p> <p>For item no 2,3,4 : Only those vendors to quote who are Original Equipment Manufacturers of KEY FOR HEXAGONAL SOCKET SCREW</p> <p>For item no 6 : Only those vendors to quote who are Original Equipment Manufacturers of PLIERS</p> <p>Authorized dealer/distributor/stockist/channel partner of Original Equipment Manufacturers of CBN Grinding Wheel may quote, however, Valid Authorization certificate from Original Equipment Manufacturer to be furnished with the offer.</p>	Vendor to confirm & submit details	
01.02	Vendor of OEM to provide proof of supply of any supplied item as per 01.01 above. Contact details of customer like name, address, phone no., email id etc. to be provided.	Vendor to submit details	
01.03	Documentry proof to be provided from customer (referred in 1.02 above) by vendor of OEM mentioning satisfactory acceptance of supplied items.	Vendor to submit	
01.04	BHEL reserves the right to verify the information provided by vendor. BHEL may also visit vendor works. In case the information provided by vendor is found to be false/ incorrect/unsatisfactory, their offers shall be rejected.	Vendor to accept	



 (Harshit/EE-TR)
 हरषित आनन्द/Harshit Anand
 वरि. अभियन्ता-टूल रूम
 Sr. Engineer-Tool Room
 की.एच.ई.एल., हीप, हरिद्वार
 BHEL, HEER, HARIDWAR

	CORPORATE STANDARD		AA 614 21 00		
			Rev. No. 04		
			PAGE 1 OF 2		
WRENCH (SPANNER), OPEN JAW, DOUBLE ENDED (FOR GENERAL PURPOSES)					
1.0 SCOPE : This standard covers the dimensions and other requirements of Double ended Open jaw Wrenches (Spanner) for general purposes (Torque series C).					
2.0 DESIGNATION: A double ended open jaw wrench (spanner) for general purposes, torque series C, having nominal width across flats S1=22mm and S2=24mm shall be designated as:					
2.1 On indents: DE wrench (spanner), Open jaw, GP series C - 22 x 24: AA 614 21 00.					
2.2 For issuing enquiries and on purchase orders: Delete BHEL standard number from the above designation and add the following given information under CI 4.0.					
2.3 Abbreviated Description: DBL ENDED OPEN JAW WRENCH C- 22 X 24					
3.0 MATERIAL: Alloy steel - T 50 Cr4 V2 as per IS: 3748.					
4.0 COMPLIANCE WITH STANDARDS:					
4.1 Dimensions, Marking and other General requirements: To conform to IS: 2028 - 2004.					
4.2 Workmanship, Finish, Preservation and Packing: To conform to IS:6131.					
4.3 Material: Alloy steel - T 50 Cr4 V2 as per IS: 3748.					
4.4 Hardness: 382 HV (39 HRC), min.					
5.0 REFERRED STANDARDS (Latest Publications Including Amendments): 1) IS:2028 2) IS: 3748 3) IS:6131					
Revisions : Cl. 32.6.13 of MOM of WG-T00LS			APPROVED : INTERPLANT STANDARDIZATION COMMITTEE (WG-TOOLS)		
Rev. No. 04 Dt:15.12.2005	Amd.No. Dt :	Year :	Prepared TRICHY	Issued Corp. R&D	Dt. of 1st Issue FEB., 1982

COPYRIGHT AND CONFIDENTIAL
 The information on this document is the property of BEARAT HEAVY ELECTRICALS LIMITED
 It must not be used directly or indirectly in any way detrimental to the Interest of the company.

C. S. 605

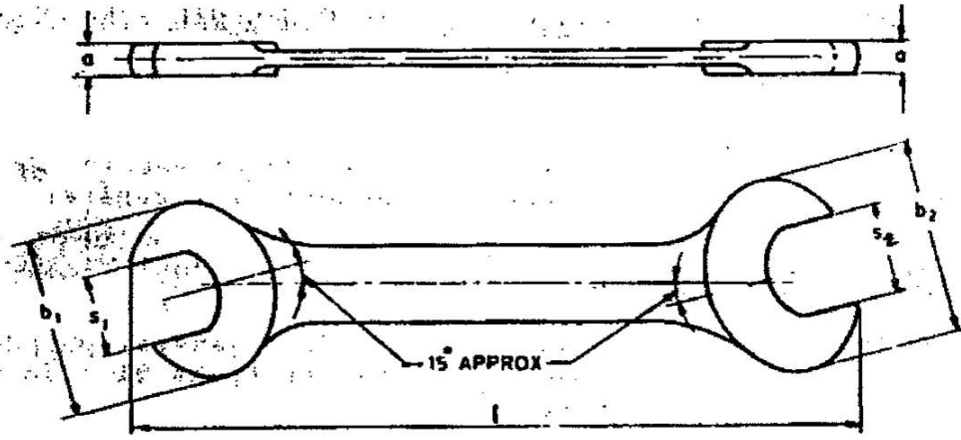
CORPORATE STANDARD



All dimensions in mm:

Nominal width across flats S1 X S2	a, max	b1, max	b2, max	l		Sub-code
				max.	min.	
6 x 7	3.5	15.5	17.5	100	90	108
8 x 9	4.0	20.5	22.5	110	100	116
10 x 11	5.5	24.5	26.5	130	115	124
12 x 13	5.5	28.0	30.0	145	130	132
14 x 15	6.0	34.0	36.0	160	140	140
16 x 17	7.0	37.0	39.0	165	150	159
16 x 18						
17 x 19						
18 x 19	7.5	41.0	43.0	180	165	167
21 x 23	9.5	47.0	50.0	230	210	175
22 x 24	9.5	49.0	53.0	230	210	060
24 x 26	10.0	53.0	56.0	255	230	183
24 x 27						
27 x 30	11.5	60.0	65.0	285	255	078
27 x 32	12.5	60.0	70.0	285	255	191
30 x 32	12.5	65.0	70.0	285	255	205
32 x 36	13.5	70.0	80.0	320	290	086
36 x 41	15.0	80.0	90.0	365	330	213
41 x 46	16.0	90.0	100.0	400	365	094
46 x 50	17.0	100.0	110.0	440	400	221

Note: Details of sizes standardized at Corporate level only are shown above. For details of sizes stocked at Plant level, refer, annexure.



CORPORATE STANDARD

AA 614 51 00

PAGE 1 OF 2

SUPERSEDES THE EARLIER CS UNDER THE SAME NO.

KEY FOR HEXAGON SOCKET SCREW

1. **SCOPE:**

This standard covers dimensions and other requirements of hexagon socket screw keys.

2. **DESIGNATION:**

A hexagon socket screw key of nominal width size $s = 6\text{mm}$ (width across flats) shall be designated as:

2.1 On Indents: Hexagonal socket screw key 6 - AA 614 51 00.

2.2 For issuing enquiries and purchase orders: Delete the Corporate standard No. from the above designation and add the information given under clause 5.

2.3 Abbreviated Description: HEX SOC SCRU KEY - 6

3. **MATERIAL:**

01 | Suitable steels such as T50 Cr4 V2 of IS:3748.

4. **HARDNESS:**

Upto and including 6mm - 52 HRC min.
 8mm - 50 HRC min.
 10 to 14mm - 48 HRC min.
 17 to 36mm - 45 HRC min.

5. **COMPLIANCE WITH STANDARDS:**

Dimensions, tolerances, material, hardness, marking, packing, and other general requirements to conform to IS:3082 - 1988

01 | (Reaffirmed 1998)

COPYRIGHT AND CONFIDENTIAL
 The information on this document is the property of BHARAT HEAVY ELECTRICALS LIMITED.
 It must not be used directly or indirectly in any way detrimental to the interest of the company.

Revisions:

Brought upto date

Approved:

INTERPLANT -WG (TOOLS)
 STANDARDIZATION COMMITTEE

Rev. No. 01	Amd. No 01	Reaffirmed	Prepared	Issued	Date
Dt. July '93	Dt. 15-03-2003	Year: 1998	TIRUCHY	CORP. R&D	4 Dec. '81

CS-536

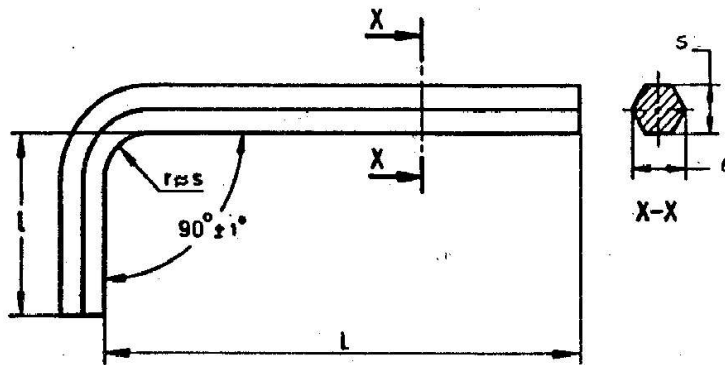

All Dimensions in mm.

Nominal size s	e		L	l	Sub-Code
	max.	min.			
1.5	1.68	1.63	45	14	176
2.0	2.25	2.18	50	16	184
2.5	2.82	2.75	56	18	036
3	3.39	3.31	63	20	044
4	4.53	4.44	70	25	052
5	5.67	5.58	80	28	060
6	6.81	6.71	90	32	079
8	9.09	8.97	100	36	095
10	11.37	11.23	112	40	109
12	13.65	13.44	125	45	117
14	15.93	15.70	140	56	125
17	19.35	19.09	160	63	133
19	21.83	21.32	180	70	141
22	25.05	24.71	200	80	150
24	27.33	26.97	224	90	168
27	30.75	30.36	250	100	192
32	36.45	35.98	315	125	206
36	41.01	40.50	355	140	214

NOTE: Details of sizes standardized at Corporate level only are shown above. For details of sizes stocked at plant level, refer annexure.

COPYRIGHT AND CONFIDENTIAL.
 The information on this document is the property of BHARAT HEAVY ELECTRICALS LIMITED.
 It must not be used directly or indirectly in any way detrimental to the interest of the company.



CORPORATE STANDARD

ADJUSTABLE WRENCH, SINGLE ENDED, OPEN JAW

1.0 SCOPE

This standard covers the dimensions and other requirements of single ended, open-jaw, adjustable wrenches, type-A, grade 1.

2.0 DESIGNATION

An adjustable wrench of type-A, grade 1 and nominal size 200 mm shall be designated as

2.1 On indents

Wrench A 200 grade 1 – AA6145200

2.2 For issuing enquiries and on purchase orders

Delete BHEL standard number from the above designation and add the information given under clause 5.0.

2.3 Abbreviated Description

WRENCH A – 200 GRADE - 1

3.0 MATERIAL

Steel conforming to IS: 963.

4.0 HARDNESS

Frame, handle & jaw	:	40 - 48 HRC
Worm	:	35 - 45 HRC
Worm pin	:	25 - 30 HRC

5.0 COMPLIANCE WITH STANDARDS

Dimensions, tolerances, material, hardness, marking, packing and other requirements:

To conform to IS: 6149-1984

6.0 REFERRED STANDARDS (Latest Publications including Amendments)

- 1) IS: 963

Revisions:
Clause 34.1 of MOM of MRC-Tools

APPROVED:
INTERPLANT MATERIAL RATIONALISATION
COMMITTEE – MRC(T)

Rev. No.02	Amd. No.	Reaffirmed	Prepared	Issued	Dt. of 1 st Issue
Dt:15-01-2005	Dt:	Year:2014	HPBP, Trichy	Corp. R&D	01-02-1982

CORPORATE STANDARD

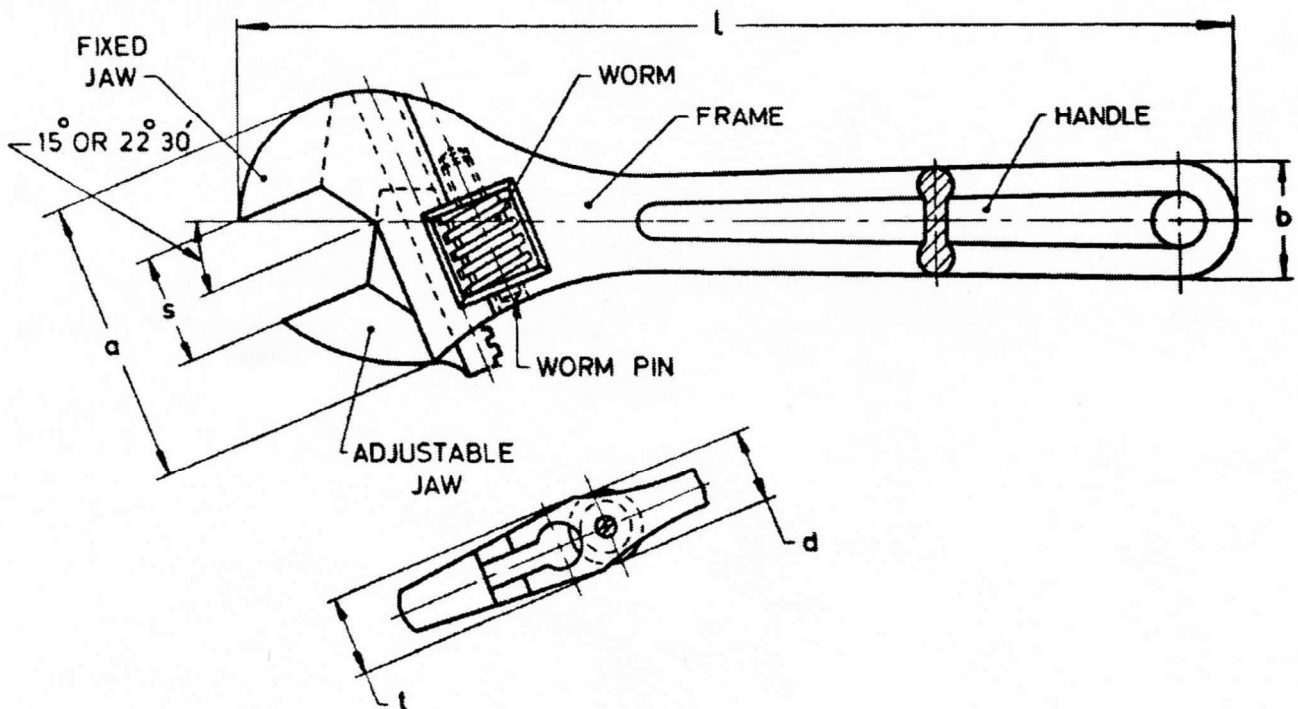

ALL DIMENSIONS ARE IN 'mm'

NOMINAL SIZE	l	TOLERANCE ON ' l '	$S \begin{smallmatrix} +3 \\ 0 \end{smallmatrix}$	a	b	t	Sub-Code
100	100	+ 10 0	13	32	15	8.5	030
150	150		18	45	18	11.5	049
200	200		24	58	22	14.0	014
250	250		27	65	25	17.0	057
300	300		34	80	30	20.0	022
450	450	+ 15 0	55	120	40	22.5	065

NOTE:

- 1) Details of sizes standardized at corporate level only are shown above.
- 2) For details of sizes stocked at plant level refer annexure issued by plant.

41/5/202
CS-50



CORPORATE STANDARD

AA 616 06 00

Rev. No. 02

PAGE 1 OF 2

PLIER - COMBINATION SIDE CUTTING INSULATED

1.0 SCOPE:

This standard covers the dimensions and other requirements of combination side cutting pliers, insulated.

2.0 DESIGNATION:

A combination side cutting plier insulated of nominal size 160 mm shall be designated as:

2.1 On indents: Combination Plier 160 – AA 616 06 00.

2.2 For issuing enquiries and on purchase orders:

Delete BHEL Standard Number from the above designation and add the information given under Clause 5.0.

2.3 Abbreviated Description: COMB SIDE CUTG PLIER – 160

3.0 MATERIAL:

Steel conforming to 65 T6, 70 T3 and 75 T6 of IS : 3749.

4.0 HARDNESS:

4.1 Nose and body : 350 to 550 HV (36 to 52 HRC)

4.2 Side Cutters : 550 to 750 HV (52 to 62 HRC)

5.0 COMPLIANCE WITH STANDARDS:

5.1 Dimensions, tolerances, material, hardness, packing and other requirements:

To conform to IS: 3650-1981.

5.2 The handle shall have a durable rubber or plastic insulation which shall withstand test laid down in cl.9.6 of IS : 2615.

6.0 REFERRED STANDARDS (Latest Publications Including Amendments):

1) 2615

2) IS:3650

3) IS:3749

Revisions :

CI 32.6.17 of MOM of WG-Tools

APPROVED :

INTERPLANT
STANDARDIZATION COMMITTEE (WG-TOOLS)

Rev. No. 02	Amd.No.		Prepared	Issued	Dt. of 1st Issue
Dt:15.12.2005	Dt :	Year :	TIRUCHY	Corp. R&D	February, 1982

CORPORATE STANDARD

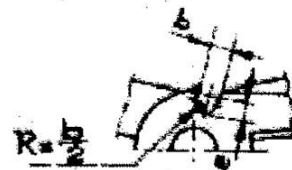
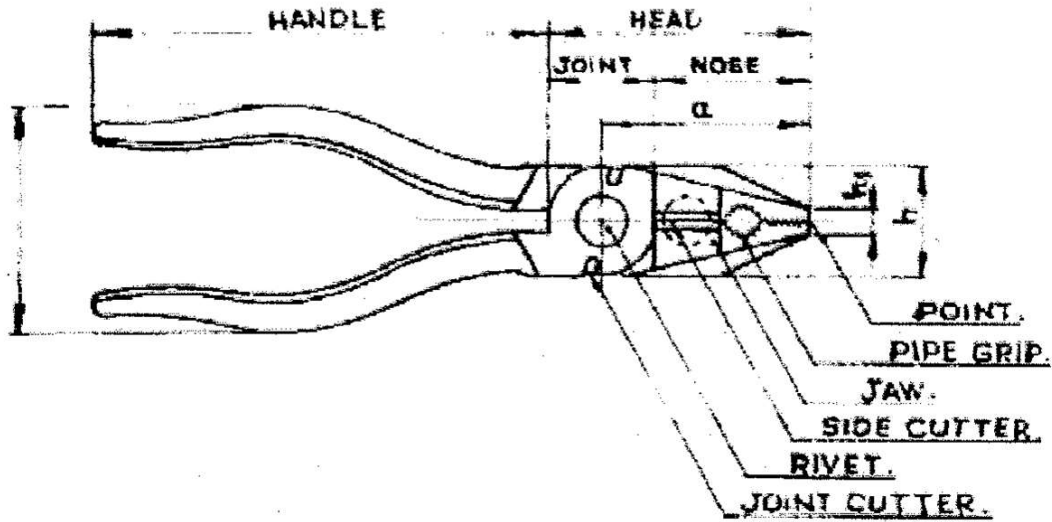

Details of joint cutter

All dimensions in 'mm'

Nominal Size	c ±10	a ±5	b min	d1 ±5	e min	h ±3	ht ±3	t ±1	Sub-Code
160	160	45	2.5	45	4	23	7	9.5	010
200	200	55	2.5	50	4	30	8	11.0	028
250	250	65	2.5	50	4	35	12	12.0	036

NOTE:

Details of sizes standardized at Corporate level only are shown above.

For details of sizes stocked at plant level refer annexure.