

TENDER ENQUIRY NO.: X/6620/RC0257

SUB:- TERMS & CONDITIONS FOR FABRICATION OF WATER BOXES

NIT-Notice Inviting Tender

Salient Details of Notice Inviting Tender (NIT)		
Sl. No.	Issue	Description
1.	Item details	As per Enquiry Annexure X/6620/RC0257
2.	Issue of Tender Documents	From BHEL eProcurement website https://eprocurebhel.co.in/nicgep/app (Tender documents will be available for downloading from BHEL e-Procurement website till due date of submission)
3.	Due Date Of Offer Submission	Date: 19-10-2023 Time: 13:45 hrs https://eprocurebhel.co.in/nicgep/app Offer to be submitted in online only through e-procurement Portal. (Bidders are requested to visit website to view corrigendum/ addenda/ amendments/ extension/ modification etc. before submitting offer).
4.	Opening of Tender (Techno-Commercial Bid)	Date: 19-10-2023 Time: 14.00 Hrs Notes: This tender being an e-tender, it shall be opened online only through the E-Procurement Portal. Participating bidders may witness the Opening online only.
5.	Cost of Tender	INR 2000/- (If hard copy of tender document is required from BHEL otherwise not applicable.)
6.	EMD (Earnest Money Deposit)	Rs. 2,00,000
7.	Schedule Of Pre-Bid Discussion	Not Applicable
8.	Integrity Pact & Details of Independent External Monitor (IEM)	Not Applicable
9.	Latest Updates	Latest updates on the important dates, Amendments, Correspondences, Corrigenda, Clarifications, Changes, Errata, Modifications, Revisions, etc to Tender Specifications will be hosted in BHEL e-tender portal https://eprocurebhel.co.in/nicgep/app and not in the newspapers. Bidders to keep themselves updated with all such information

Please submit your offer only for the above requirement subject to our **GENERAL INSTRUCTIONS AND STANDARD TERMS & CONDITIONS (Version: June-2021, Rev.06)**. Please visit our website www.hwr.bhel.com for General Instructions and Standard Terms & Conditions (GISTC) for Tender Enquiries. All the bidders/vendors must ensure compliance of these GISTC. GISTC can also be referred by login to B2B Portal for Registered Vendors.

Tender Fee & EMD (If Applicable) will be submitted in the form of Pay Order / Demand Draft (drawn in favor of 'BHEL HARIDWAR') only. It may be noted that if hard copy of any tender document is required, then the same may be collected against copy of Pay Order / Demand Draft of requisite tender fee (while original to be submitted with Part-I).

TENDER ENQUIRY NO.: X/6620/RC0257

If EMD is not submitted along with the offer, then the offer may not be considered.

For E-Payment, the RTGS details are mentioned as below:

Bank Details	SWIFT Details of bank
STATE BANK OF INDIA RANIPUR BRANCH, OPP: BHEL MAIN GATE, SECTOR-5, RANIPUR, HARIDWAR, UTTRAKHAND, INDIA PIN CODE : 249403	SWIFT NO.: SBININBB225 CC ACCOUNT NO.: 10667995458 IFSC CODE: SBIN0000586

As per notification reference no. NSIC/HO/GP/15(4)/2013-14 dated 07.07.2013 Micro & Small Enterprises (MSEs) are not required to submit Tender fees. A Valid MSE/MSME certificate such as Udyog Aadhar (UAN)/Udyam Certificate/NSIC/EM (Part-II) etc. issued from competent authority shall be submitted in support of Micro & Small Enterprises (MSEs).

“As per the OM No. F. No. 1(2)(1)/2016-MA dated. 09.02.2017 issued from the Office of Development Commissioner (Micro, Small & Medium Enterprises), “Traders and agents should not be allowed to avail the benefits extended under the PP Policy.”

Central / State – PSUs / Government departments are exempted from submission of EMD subject to approval by BHEL management.

BHEL will forfeit the EMD if, the successful bidder / vendor refuses to honor the order after award of the same on him and / or withdraws his bid and / or unilaterally changes the offer and / or any of its terms & conditions within the validity period.

INSTRUCTIONS TO BIDDERS FOR SUBMITTING OFFER

TECHNICAL QUALIFICATION: Technical Requirement, Pre-Qualifying Requirements/PQR to be submitted. It is the mandatory requirement. Offer of vendors not meeting these requirements may not be considered.

ESSENTIAL INSTRUCTIONS

The tender shall be **submitted in two parts** in separate cover as described below on or before the due date:

Part I (Cover-1) - Containing the following:

1. Techno -Commercial Bid
2. Tender Fee & EMD (Earnest Money Deposit) Or Valid certificate/Document towards exemption of Tender fee and/or EMD (applicable for Micro and small Enterprises, Central / State – PSUs / Government departments, PMD vendors etc.)

Part II (Cover-2) - Containing Price Bid in attached Format

Bidders against tender will necessarily have to obtain class – III DSCs. Procedure for application available on www.bhel.com.

E-Procurement Portal Inputs

TENDER ENQUIRY NO.: X/6620/RC0257

Procedure for Submission of Offer for E – Tender-Procedure for Submission of Tender is available in the “Bidder Manual for BHEL Bidders” at E-tender portal <https://eprocurebhel.co.in/nicgep/app> . Terms and conditions mentioned therein shall form integral part of the NIT and bidders shall abide by the same.

Hardware and Software requirements for participating in e-tender

Please refer the website for the minimum system requirements and setting document for Bidders under the link: <https://eprocurebhel.co.in/nicgep/app>

Digital Signature

To know the procedure for obtaining Digital Signature Certificate (DSC), suppliers who are not having the DSC are advised to visit our website [http://www.bhel.com/home.php/Tender Notifications/Sample Checklist](http://www.bhel.com/home.php/Tender%20Notifications/Sample%20Checklist).

NIC portal Helpdesk Contacts

For any technical related queries please call at 24 x 7 Help Desk Number
0120-4001 002
0120-4200 462
0120-4001 005
0120-6277 787
International bidders are requested to prefix 91 as country code

Email Support

Address: A) For any Issues or Clarifications relating to the published tenders, bidders are requested to contact the respective Tender Inviting Authority Technical - support-eproc@nic.in

Note

Offers/tenders submitted in the E-tender portal shall only be considered for further evaluation. Offers sent by FAX / E-mail / any mode other than E-tender would not be entertained.

The Tenderers must submit their Tenders, as detailed below:

SPECIAL NOTE: All documents to be submitted should be uploaded in respective places in the E-Tender portal as per the list mentioned given in this NIT. BHEL shall not be responsible for incomplete documents.

TERMS & CONDITIONS FOR RATE CONTRACT
(FABRICATION OF WATER BOXES)

1. SCOPE OF WORK :-

1.1 This Rate Contract is for complete fabrication of Water Boxes BHEL material 'or' combination of BHEL & Party material.

Expected Load during year = 1360 MT

1.2 Final stress relieving, shot blasting, final painting and final machining are excluded from the Party's scope of work.

1.3 Subcontractor can use following grades of materials up to sizes as specified against each grade, which are easily available of required quality in the market:

SL	MATERIAL CATEGORY	DESCRIPTION	REQUIRED SIZES
1	AA10108	<i>Structural steel standard quality (plates, sections, strips, flats,bars)</i>	<i>Upto 63mm</i>
2	AA10119	<i>Structural steel standard quality (plates, sections, strips, flats,bars)</i>	<i>Upto 63mm</i>
3	Rolled sections like angles, beams, channels etc		Any size
4	AA10208	<i>Hot rolled carbon steel bars, Grade ; 40C8-Normalised</i>	<i>Upto 63mm</i>
5	AA10109	<i>Hot rolled carbon steel bars</i>	<i>Upto 63mm</i>
6	AA10218	<i>Hot rolled carbon steel bars -H&T</i>	<i>Upto 63mm</i>
7	BQ-AA10401	<i>Carbon steel plates - Intermediate and high temperature</i>	<i>Upto 50mm</i>

8	AA10152	Steel Tubes – Electric Resistance Welded/ Submerged Arc welded	-
9	AA10147 (ERW pipe of any OD)	Carbon Steel Pipes– Electric Resistance Welded/ Submerged Arc welded	-
10	AA10111	Hot Rolled Carbon Steel Sheet (410N/mm2 Tensile)	2.5 to 4.0
11	AA10112	Bright Steel Bars and Sections (Standard Quality) I-Beam/ Equal Angles	Small Sections
12	AA10113	Hot Rolled Carbon Steel Sheet (330N/mm2 Tensile)	-
13	AA10114	Cold Rolled Carbon Steel Sheet -Ordinary	0.4 to 2.5
14	AA10115	Cold Rolled Carbon Steel Sheet -Annealed Drawing	0.4 to 3.15
15	AA10183	Steel Chequered Plates	-
16	AA10179	Expanded Metal Steel Sheets	-
17	AA10730	Austentic Stainless Steel Sheets, Plates and Strips – Solution Annealed (ASTM A240M, Type 316L)	2 mm

Sub-contracting of items for sizes beyond above mentioned grades, will be done with BHEL material. Other grades of material which are not covered above, sub-contracting will be done with BHEL material. However, extra wide plates (width more than 2500 mm) shall be supplied by BHEL. The SS Perforated pipe, MS drain pipe, SS 5 mm plate, SS boss material will be given by BHEL. However, some party material may be provided by BHEL as per BHEL requirements.

- 1.4 Cleaning of parts, removal of mill scale from components prior to assembly will also be in scope of sub-contractor.
- 1.5 The rate(s) should be quoted in Rupees/Kg in **Price bid**. The rates shall include all consumables as stipulated in Drawings /WPS/QP/MP including D. P. Test and UT/RT (if any).
- 1.6 Only BHEL/Lloyds approved qualified welders must be employed on the job.
- 1.7 Electrodes/consumables to be procured from BHEL/ customer approved vendors

- 1.8** Drg No., CBOM, Part drawing are attached of Front Water Box Drg No. 01603170062-00 are for reference only (ordering will be done based on actual requirement).
- a) Material OF IT NO-1,2,15-1,16,19-6, 19-7, 20-1, 22-1, 22-2, 25 & 27 WILL BE SUPPLIED BY BHEL.
 - b) Material OF TEM NO-19-11, 19-12, 19-13, 20-4, 20-5, 20-6, 22-5, 22-6, 22-7, 28 & 30 WILL BE ASSEMBLED AT BHEL & WILL NOT BE SUPPLIED TO VENDOR
 - c) ALL OTHER ITEMS WILL BE PARTY MATERIAL.

2. VALIDITY:-

The validity of offers by vendors should be at least for a period of **90 days for this enquiry from the date of enquiry opening.**

The rate contract shall be valid for a period of **ONE YEAR** for issue of orders from the date of award of final contract. However, BHEL reserve the right to extend the Rate Contract with same terms & conditions for additional one year with mutual agreement from both the side.

3. SUBMISSION OF OFFERS: -

Open tender is hoisted on the <https://eprocurebhel.co.in/nicgep/app> and no hard copy of document is provided by BHEL, no tender fee shall be insisted upon from the bidders.

The offer is to be submitted in **two parts** on NIC portal only on website:

<https://eprocurebhel.co.in/nicgep/app>

BHEL reserves the right to reject any or all the tenders either in full or part thereof without assigning any reasons thereof.

4. TRANSPORTATION:-

Transportation of PPMIV material (raw material) will be in scope of BHEL. However, the same will be loaded into the cost quoted by vendor in RA sheet.

Vendor to deliver fabricated/machined/formed items to BHEL Haridwar at their own cost.

5. DELIVERY: - F.O.R. HEEP, BHEL Hardwar.

6. DELIVERY SCHEDULE & LD CLAUSE:-

In case of BHEL material `or` Combined (BHEL & Party) material: within 90 days after receipt of material from BHEL. In case last material of more than one water boxes are sent together than delivery will be 90 days for 1st water box and 120 days for 2nd water box and 150 days for 3rd water box and so on.

7. LD CLAUSE: -

@ 0.5% per week subject to max 10% for the delayed portion of supply. The entry date mentioned by CISF on the challan at BHEL material gate will be taken as material receipt date.

8. INSPECTION: -

- a. The inspection will be carried out by BHEL/BHEL nominated inspection agency at party works strictly as per drawing/ standard and approved quality plan requirements. All facilities and equipment, calibrated instruments and standard gauges required for inspection shall be provided by the fabricator during inspection. In some cases, inspection by customer's representatives like NTPC/ RITES etc. may also be carried out at Party's works and CHP clearance may be obtained. No additional charges will be paid on this account.
- b. The party is to follow system for material control as per BHEL Quality Control system.
- c. Material Used should be procured from BHEL approved vendor only.
- d. Identification marks shall be punched on each item by the vendor i.e. Purchase Order No., Drawing No., IR No. & W.O. no. etc.
- e. Aesthetic look is to be maintained as per drawing requirement.
- f. Vendor to submit quality plan/mfg. plan, as applicable, in Microsoft word format with seal and signature of the vendor for review and approval of customer through BHEL, Haridwar prior to start of work.
- g. All the inspection calls are to be given to quality & AIX-F executive.
- h. Documents of dispatch, delivery challan, IR, all relevant quality documents (TC, dimensional reports, UT, RT, DPT reports etc) are to be submitted in three sets (one each to AIX –F executive, Finance and store).
- i. Firm quality requirement will be provided while placing the orders against this rate contract.

9. GUARANTEE CERTIFICATE:-

The vendor shall warrant that the supplied fabricated assemblies/items comply fully with the drawings and other technical conditions. If the fabrications/items are found defective owing to faulty workmanship/incomplete work within a period of eighteen (18) months from the date of dispatch, the vendor shall make good of it/replace the same free of cost. Alternatively, the rework/replacement charges will be recovered.

10. PAYMENT TERMS:-

90% after acceptance & final clearance of SRIV. 10% after FTS and final accountal of material.

No packing and forwarding charges will be paid extra.

In case of rejection, total cost of material will be recovered in case of BHEL Material and no labour cost will be paid.

For MSEs (covered under MSME Act) which are registered and periodically renewed with BHEL, the payment will be made within 45 days or as prescribed in the relevant act.

Detailed terms at clause 10.0 of GISTC Rev. 06, June 2021.

11. Bank Guarantee/Indemnity Bond: -

10 % Bank Guarantee and 90% Indemnity Bond for the value of materials to be given by vendor for free issue materials. Material value will be calculated on PPMIV/Challan value basis. On intimation from BHEL regarding BG & IB, the same shall be provided by the vendor (s) within 15 Days. If suitable BG and IB are not submitted to BHEL within 15 days of intimation, then the amount of days delayed beyond 15 days after intimation will be deducted from delivery days of that item and consequent PO amendment will be issued.

For Example: If intimation for requirement of BG & IB of an item of a PO is given to vendor on 01.04.2023 from BHEL, then vendor should mandatorily provide required BG and IB by 15.04. 2023. In case, the vendor provides the same by 30.04.2023, then the difference of 15 days (between 30.04.2023 & 15.04.2023) will be deducted from delivery days of that item and consequent PO amendment will be issued.

12. GST: -

As per clause 11.0 of GISTC (attached). it will be as applicable as per Govt. guidelines /circulars.

13. REJECTION:-

No rejection allowance is allowed. BHEL would recover full value of the material damaged. In case of defect observed on material supplied by BHEL at any stage of operations and material stands rejected, then BHEL will pay for the part operations performed by the sub-contractor and such payment shall be made after joint certification by the QC, Technology and Shop Planning Personnel.

14. SCRAP:-

- a. Generated scrap is to be retained by the sub-contractor. This scrap is chargeable. Scrap rate will be calculated based on the monthly market scrap price Published in MSTC Bulletin/any other document under category of scrap MELTING SCRAP. The date of receipt of material will be considered for calculating the scrap value as applicable for that month. For this purpose, MSTC rates of a particular month shall be applicable four months preceding these rates for example rates of June MSTC Bulletin/ any other document under category shall be applicable for the month September. The calculated monthly price for charging scrap will be rounded off to two decimal places of Rupee. The present monthly price applicable for September 2023 is Rs. 37.76 per Kg. TDS on scrap shall also be applicable.
- b. BHEL would recover the amount of GST and Trade Tax as applicable from the sub-contractor's account in lieu of scrap retained by them. The difference

between raw material weight and finalized weight shall be considered for the calculation of scrap generation.

- c. A 3% invisible cutting allowance shall be given on the finished weight.

15. RECTIFICATION: -

(A) Any rectification (noticed at Shop) arising out of the fabrication/wrong manufacturing done by the sub-contractor, will have to be rectified within 10 days by the sub-contractor at their own cost. Otherwise BHEL will be free to take necessary action as deemed fit and consequence/cost of the same will be to subcontractors-account.

(B) In case of material is not found suitable for use & finally rejected, the total cost of BHEL material shall be recovered from the vendor & no labour cost will be paid.

16. EXTRA RATES:-

In case, extra work is required due to change in Drawing / any deviation in fabricated weight at a later stage (duly verified by our Engineering Dept.), extra charges may be paid and purchase order will be amended.

In case extra work is required due to change in Drawing/ technology / extra joints (owing to non-availability of required size of raw material) / defects like laminations if any on BHEL supplied plates etc. / any deviation in fabricated weight (duly verified by WT), extra charges will be paid and purchase order may be amended accordingly.

17. SUB CONTRACTORS FABRICATION CAPACITY/DISTRIBUTION OF LOAD:-

The sub-contractor must indicate the fabrication capacity reserved for BHEL & specifically for this enquiry as per annexure-A considering the following points.

Enquiry has been issued with following terms & conditions :

- 1) In view of shop manufacturing capacity constraints & to cope up with the increased fabrication load, it is proposed to enter into rate contract with 5 BHEL approved subcontractors or the case may be. Load distribution among four evaluated subcontractors shall be, L-1= 35%, L-2= 25%, L-3= 18%, L-4= 12% and L-5=10% respectively out of BHEL load while placing the orders. Load distribution shall be done after counter offering L-1/lowest rate to L-2, L-3, L-4 and so on vendors.
- 2) If any of the vendor (L-2 to L-5) does not accept the c/offer rate, then subsequent vendors (L-6 to L-n, where n is the number of bidders) shall be approached.
- 3) This process will continue till we get 4 such vendors who accept the counter offered rates. Accordingly, they will be ranked as L2, L3, L4 & L5 taking into account their ranking before counter offer.

- 4) If none/any of the vendor (L-2 to Ln or participated in RA) accept the c/offer rate and L2/L3/L4/L5 vendors are not identified after counter offer, then L-1 vendor shall be approached for maximum discount. Further the ordering on all the vendors shall be done maintaining the initial load ratio to the possible extent.
- 5) The total allocated load to a particular vendor shall not exceed the declared capacity by the vendor. In case the declared capacity of any vendor is less than the allocated load, the remaining load shall be distributed among vendors in equal ratio within their declared capacity subject to acceptance of L1 counter offered rates. i.e. For example, if L-1 vendor will get the load of 535 MT, but in case the declared capacity of L-1 vendor is 500 MT, the remaining load of 35 MT shall be distributed among L-2 and so on vendors in equal ratio within their declared capacity and so on or the case may be.
 - a) Subsequent ordering shall be done based on performance and execution of orders in time as per PO. Delivery
 - b) Vendor must indicate their annual fabrication capacity and details as per Annexure –A enclosed for BHEL reference.

18. EVALUATION OF BIDS:

All vendors will be assessed on total cost to BHEL basis that includes freight, taxes, ITC etc.

L1 Vendor must provide break up of Basic BM & PM rate (in Rs. /Kg) post RA in price confirmation sheet.

In the course of evaluation, if more than one bidder happens to occupy L1/subsequent status, effective L1 /Subsequent rank will be decided by toss/draw of lots, in the presence of respective L1 bidder(s) or their representative(s). Ranking will be done accordingly. BHEL's decision in such situation shall be final and binding.

NOTIONAL L1, L2, L3 etc. Sub-contractor will be decided based on the weighted rates calculated as per formula given below:-

$$\text{Rate (Rs. Per Kg)} = (0.25 B_1 + 0.75 P_1)$$

Where,

- 0.25 within bracket indicates 25% load with BHEL material approx.
- 0.75 within bracket indicates 75% load with Party mat. approx.
- B₁ indicates labour rate per kg with BHEL Material.
- P₁ indicates rates of fabricated assy. per kg with Party material.

19. REVERSE AUCTION: -

"BHEL shall be resorting to Reverse Auction (RA) (Guidelines as available on www.bhel.com) for this tender. RA shall be conducted among the techno-commercially qualified bidders.

Price bids of all techno-commercially qualified bidders shall be opened and same shall be considered for RA. In case any bidder(s) do(es) not participate in online Reverse Auction, their sealed envelope price bid along with applicable loading, if any, shall be considered for ranking.”

For detailed terms and conditions of RA guidelines, kindly refer www.bhel.com.

20. PRICE VARIATION CLAUSE:-

No price variation clause is applicable on labour rates. However, the price variation in party material is applicable as below: -

The variation in fabrication cost will be calculated based on the average rates of following raw materials (commonly used in General fabrication items), of Quarterly Price list given by BHEL Trichy of their rate contract operated with steel vendors finalized through the bulk steel Tendering

- 8-10 mm IS 2062 Gr-B Unnormalised.
- >12-20 mm IS 2062 Gr-B Normalised.
- >20-40 mm IS 2062 Gr-B Normalised.
- Above 40 mm IS 2062 Gr-B Normalised.

The variations in fabrication rate will be calculated based on the average rate of above raw material of Quarterly Price list given by BHEL Trichy of their rate contract operated with steel vendors. This price variation clause will be applicable on the date of receipt of material as mentioned in CISF CHALLAN/c-note.

The Base rate for calculation of PVC will be taken of the quarter in which RC is finalized with L1 vendor (awarded to L1 vendor) i.e. if RC is finalized in May 2023 then base rate will be taken for the quarter of April – June 2023.

The Settled Party material rates shall be taken as reference for ordering purpose. For a particular purchase order the applicable rates will be of the month 90 days prior to the actual delivery if item is supplied within the scheduled delivery of 90 days after receipt of material from BHEL.

In case of late delivery i.e. beyond 90 days the rates lower of the two i.e. actual delivery and maximum scheduled delivery shall be applicable. The purchase order may be amended accordingly.

In case of BHEL/combined material if the vendor supplies the item early i.e. before scheduled delivery and date of delivery is less than 90 days from the date PO was placed, the PVC rate will be applicable of the quarter in which PO was placed.

If hold is put up on manufacturing of items by BHEL. PVC rate will be applicable as per new delivery schedule.

21. RISK PURCHASE: -

In case of abnormal delays (beyond the maximum late delivery period as per LD clause) in supplies / defective supplies or non-fulfillment of any other terms and conditions given in Purchase Order, BHEL may cancel the Purchase Order in full or part thereof, and may also make the purchase of such material from elsewhere / alternative source at the risk and cost of the supplier. BHEL will take all reasonable steps to get the material from alternate source at optimum cost. If bidder does not agree to the above Risk Purchase Clause, BHEL reserves the right to reject the offer. In case for compelling reasons BHEL accepts the offer without acceptance of

this clause by the bidder and in the eventuality of Risk Purchase, appropriate action will be taken as per BHEL extant rules. This will be without prejudice to any other right of BHEL under the contract or under General Law Action against Bidders / vendor / supplier / contractor in case of default:

In order to protect the commercial interests of BHEL, BHEL shall take action against supplies / contractors by way of suspension of business dealings, who either fail to perform or are in default without any reasonable cause, cause loss of business/ money/ reputation, indulge in malpractices, cheating, bribery, fraud or any other misconduct or formation of cartels so as to influence the bidding process or influence the price etc. Suspension of Business Dealings could be in the form of "Hold" or "Banning" a supplier/ contractor or a bidder and shall be as per "Guidelines for Suspension of Business Dealings with Suppliers/ Contractors" available at BHEL's website "<https://www.bhel.com/guidelines-suspension-business-dealings-suppliers-contractors>."

22. GENERAL INSTRUCTIONS: -

22.1 No further sub-contracting to third party or sister concern by the sub-contractor is allowed Without prior permission of BHEL. If found guilty, will be debarred.

22.2 BHEL reserves the right to suspend/cancel the PO/Enquiry unilaterally without any financial repercussions, if Sub-contractor's performance is not found to be satisfactory.

22.2.1 BHEL reserves the right to revise the drawing after placement of purchase order. The prices in the purchase order will be amended according to revised drawing.

22.3 Please refer general instructions and standard terms & conditions (GISTC) for bidding against tender enquiry (version June-2021, Rev:06) the bidder/vendor must ensure compliance of these GISTC (version June-2021, Rev:06). Please refer <https://hwr.bhel.com>.

22.4 MSE suppliers are exempted for submission of EMD & Tender Fee.

22.5 Central / State – PSUs / Government departments are exempted from submission of EMD subject to approval by BHEL management.

22.6 Documents submitted with the offer/bid by the bidder should be signed and stamped in each page by authorized representative of the bidder.

22.6.1 PQR required documents is to be submitted along with the Techno-Commercial offer (PART-I).

Note: - Offer shall be entertained only after submission of duly filled, signed and stamped PQR and relevant documents. Offers of the vendor(s) not submitting this may be ignored.

22.7 Vendor Contract clause regarding GST ITC and provision for E-invoices:

(i) E-invoicing under GST is being implemented w.e.f. 01.04.2022 for all the taxable persons having turnover more than Rs. 5 Cr. It has been specified by the Govt. that it is mandatory to mention a valid unique Invoice Reference No. (IRN) and QR code as generated from Govt. portal on a Tax Invoice. Based on such information, GST ITC as claimed by BHEL in GST Returns shall be matched with the corresponding details uploaded by supplier in E-invoicing System.

(ii) In case the vendor /contractor delays or fails to provide all the documents as per the Purchase order / Work Order at the time of submitting Tax invoice to BHEL, any

subsequent financial loss to BHEL on account of vendor/contractor shall be to vendor's / contractor's account. BHEL has further right to take necessary steps to protect its interest at the time of release of payment. This further requires inclusion of IRN and QR code on tax invoice as announced by Govt. of India w.e.f. 01.10.2020.

22.8 In case of ordering against the tender, vendor should submit their invoices against goods and services immediately after supply of goods & services but not later than 30 days from the invoice date. In case of delay, consequential losses like loss of input credit and non-availability of concessional forms etc. shall be to the vendor account.

22.9 The bidders against open tender will necessarily have to obtain class – III DSC (Digital signature). Procedure for application is available on hwr.bhel.com.

22.10 Following MSE conditions shall be followed: -

UDYAM Certificate. Detailed MSE conditions is at clause no. 23.0 of GISTC Rev. 06, June 2021.

* Govt. guidelines will supersede all clauses of this tender for MSE benefits to vendor(s). MSE Suppliers can avail the intended benefits only if they submit along with the offer, attested copies of UDYAM Certificate.

Detailed MSE conditions is at clause no. 23.0 of GISTC Rev. 06, June 2021. * Govt. guidelines will supersede all clauses of this tender for MSE benefits to vendor(s).

23. "A bidder shall not have conflict of interest with other bidders. Such conflict of interest can lead to anti-competitive practices to the detriment of Procuring Entity's interests. The bidder who found to have a conflict of interest shall be disqualified. A bidder may be considered to have a conflict of interest with one or more parties in this bidding process, if:

- a) they have controlling partner (s) in common; or
- b) they receive or have received any direct or indirect subsidy/ financial stake from any of them; or
- c) they have the same legal representative/agent for purposes of this bid; or
- d) they have relationship with each other, directly or through common third parties, that puts them in a position to have access to information about or influence on the bid of another Bidder, or
- e) Bidder participates in more than one bid in this bidding process.

Participation by a Bidder in more than one Bid will result in the disqualification of all bids in which the parties are involved. However, this does not limit the inclusion of the components/ sub-assembly/ Assemblies from. one bidding manufacturer in more than one bid; or

- f) In cases of agents quoting in offshore procurements, on behalf of their principal manufacturers, one agent cannot represent two manufacturers or quote on their behalf in a particular tender enquiry. One manufacturer can also authorize only one agent/dealer. There can be only one bid from the following:

1. The principal manufacturer directly or through one Indian agent on his behalf; and

2. Indian/foreign agent on behalf of only one principal,

or

- g) A Bidder or any of its affiliates participated as a consultant in the preparation of the design or technical specifications of the contract that is the subject of the Bid, or

h) In case of a holding company having more than one independently manufacturing units, or more than one unit having common business ownership/management, only one unit should quote. Similar restrictions would apply to closely related sister companies. Bidders must proactively declare such sister/ common business/ management units in same/ similar line of business. "

- **Against vendor's replies, BHEL reserves the right to ask for more information/ documents / clarifications. Vendor's offer shall not be considered if vendor fails to furnish the document / information / clarifications as mentioned above or doesn't meet the acceptance criteria. Time period for technical/commercial clarification is 3 days.**
- Amendments/Corrigendum, if any, will be hosted on designated web site/ GePNIC Portal only. Other terms and conditions will be as per tender documents. Any vendor who is under hold (for the item)/ delisted/ banned with BHEL on date of opening of Part – 1 will not be allowed to quote for this tender. In case their offer is received, it may be out rightly rejected.
- In view of Covid-19 and present situation, the Tender Documents, Drawings, P.O copy etc. shall be sent by e-mails and shall not be sent in hard copies. Vendors to kindly note that the details sent by e-mail shall be considered for delivery against the finalized contract(s)/ P. O's placed.
- ****OFFERS SHALL BE ADMITTED THROUGH GePNIC PORTAL**
<https://eprocarebhel.co.in/nicgep/app> ONLY

24. Vendor must indicate their `MSMED` status in their un-price bid for reference. Copy of MSMED certificate may also be enclosed for reference.

Annexure-A

DESCRIPTION OF ITEMS: WATER BOX

DESCRIPTION OF ITEMS	TOTAL QTY. MT	L1 TO L5 LOAD DISTRIBUTION MT	TOTAL FABRICATION CAPACITY (MT)	CAPACITY RESERVED FOR THIS ENQUIRY (MT)	RATE (Rs. Per Kg) Tick the correct
Water Box	1360	L1=35% L2=25% L3=18% L4=12% L5=10%			Quoted / Not quoted

DATE:-

**Authorized Signature:
Name of Supplier**

Annexure - B

MAKE IN INDIA CERTIFICATE

Certificate In line with Government Public Procurement Order No. P-45021/2/2017-BE-II dt. 15.06.2017 & P-45021/2/2017-PP (BE-II) dated 28.05.2018, we hereby certify that we M/s _____(supplier name) are local supplier meeting the requirement of minimum local content (50%) as defined in above orders for the material against Enquiry No. _____ Details of location at which local value addition will be made is as follows:

_____ We also understand, false declarations will be in breach of the Code of Integrity under Rule 175(1)(i)(h) of the General Financial Rules for which a bidder or its successors can be debarred for up to two years as per Rule 151 (iii) of the General Financial Rules along with such other actions as may be permissible under law.

Authorised Signature:
(with date & seal of company)
Name of Supplier: -

TERMS AND CONDITIONS FOR RATE CONTRACT

SL.	TERMS & CONDITION	VENDOR'S ACCEPTANCE/ REMARKS
1	<u>Scope of Work</u> : - Rate Contract for complete fabrication of Water Boxes with BHEL material 'or' combination of BHEL & Party material as per Drawing/Standard, QP and Technical requirements.	
2	<u>Validity</u> : As per Clause no 2 of Terms and Conditions	
3	<u>Submission of offers</u> : As per Clause no. 3 of Terms and Conditions of Rate Contract	
4	<u>Transportation</u> : As per Clause 4 of T & C of Rate Contract.	
5	<u>Delivery</u> : Quoted rates are on F.O.R. sub-contract store, HEEP, Haridwar basis.	
6	<u>Delivery Schedule</u> : Finished component shall be delivered within 90 days after receipt of material from BHEL and as per Clause 6 of T & C.	
7	<u>LD</u> : @ 0.5% per week subject to max 10% for the delayed portion of supply, as per Clause 7 of T & C	
8	<u>Inspection</u> : It shall be done as per clause no. 8 of Terms and Conditions of Rate Contract	
9	<u>Guarantee Certificate</u> : It shall be valid for 18 months from receipt of material in BHEL as per clause 8 of T & C	
10	<u>Payment</u> : As per Clause 10 of T & C of Rate Contract.	
11	<u>Bank Guarantee</u> : 10 % BG and 90 % IB as per clause 11 of T & C of Rate Contract	
12	<u>GST</u> : It shall be applicable against documentary proof. Input Tax Credit shall be applicable and BHEL can claim benefit	
13	<u>Rejection</u> : As per Clause 13 of T & C of Rate Contract	
14	<u>Scrap</u> : As per Clause 14 of T & C of Rate Contract	
15	<u>Rectification</u> : As per Clause 15 of T & C of Rate Contract	
16	<u>Load distribution</u> : as per clause no. 17 of T & C of Rate contract	
17	<u>Evaluation of Bid</u> : as per clause no. 18 of T & C of Rate contract	
18	<u>Reverse Auction(RA)</u> : AS per standard policy of BHEL.	
19	<u>Price Variation Clause</u> : As per Clause 20 of T & C of Rate Contract	
20	<u>Risk Purchase</u> : As per Clause 21 of T & C of Rate Contract	
21	We have read clause no. 22 of terms and conditions of Enquiry and confirm to abide the same.(Clause 22.1 to 22.10)	
22	<u>Conflict of Interest</u> : Confirm acceptance of Clause 23 of T & C of Enq.	
23	<u>Integrity Pact</u> : Signed and stamped Integrity pact is to be attached alongwith offer	
24	<u>GSTC</u> : We agree for GSTC Rev.06	
25	We have submitted Make in India certificate (duly filled and signed as per Annexure-B).	
26	Rates have been quoted in indian Rupees per Kg as per Evaluation formula as per clause no 18 of T&C	

Note: BHEL reserves the right to reject any or all the offers (on techno-commercial ground) without assigning any reason thereof.

(Vendor's signature with Stamp)

PQR

Item : All Items of Indent no: 20230416 {Condenser water box (Front/Rear etc.)}

PRE-QUALIFICATION REQUIREMENT

01.00	TECHNICAL REQUIREMENT	Required	Vendor's Offer
01.01	Vendors should have experience of fabricating (cutting/bending/assembly/welding/pre-fabrication machining) and supplying of atleast 1 no. Condenser Water Box (front/rear) or equivalent having size 4000X3500mmX2500mm (LXBXH) and above and weight 15 Tons and above in last 7 years from the date of enquiry.	Vendor to Comply & submit suitable evidence	
01.02	Facilities Required: i) Lifting facility and capacity at vendor works must be EOT crane 20 Tons and above. ii) Vendor must have levelled bed plate size : Length= 6,500mm and Breadth=5,000mm and above to fabricate the job (Note: Concrete floor not acceptable). (iii) Vendor must have suitable WPS/PQR and qualified welders for welding approved by Third Party and submit documentary evidence with offer. (iv) Vendor must have cutting facility to cut plate of thickness 110 mm and above. (v) Vendor must have rolling bending facility of plate thickness 40mm and above at width of 2500mm and above. (vi) Vendor must have suitable drilling facility to drill hole of size 63mm and above in plate thickness of 70mm and above	Vendor to Comply & submit suitable evidence including technical specifications, technical brochure, photographs etc. of the facilities.	
01.03	Vendor to furnish certificate against clause 01.01 from the customer / company or end user duly confirming that Condenser Water Box (front/rear) or equivalent having size 4000X3500mmX2500mm (LXBXH) and above and weight 15 Tons and above was supplied and used for Hydro Pump or turbine/power plant/capital goods/infrastructure application OR Vendor to submit documentary evidence as per clause 1.03.	Vendor to Comply & submit suitable documents	
01.04	Vendor to furnish name of customer/company with complete contact details and month /year of previous supply along with copy of PO, type of manufacturing facility used for fabrication (assembly/welding/pre-fabrication machining), supply documents, Payment details(invoice copy) and inspection documents of supplied Condenser Water Box (front/rear) or equivalent having size 4000X3500mmX2500mm (LXBXH) and above and weight 15 Tons and above.	Vendor to Comply & submit suitable documents	
01.05	All PQR documents are to be stamped and signed in original by Vendor. In case documents and official stamp is in language other than English, documents and details of official stamp are to be translated in English and duly certified by Government agency/approved agency of Government/Embassy.	Vendor to Comply & submit suitable documents	
01.06	BHEL reserves the right to verify the information provided by vendor. In case the information provided by vendor is found to be false/ incorrect, their offers shall be rejected.	Vendor to agree	

NOTE: PQR is not restrictive

31/08/2023
 (Ravi Deshpande
 Manager (WT))

Santosh
 31/08/23
 (Santosh Gonde)
 NYC/WT

Bse
 31-08-2023
 (B.S. Arney)
 AGC (FRONT WT)

INTEGRITY PACT**Between**

Bharat Heavy Electricals Ltd. (BHEL), a company registered under the Companies Act 1956 and having its registered office at "BHEL House", Siri Fort, New Delhi - 110049 (India) hereinafter referred to as "The Principal", which expression unless repugnant to the context or meaning hereof shall include its successors or assigns of the ONE PART

and

_____, (description of the party along with address), hereinafter referred to as "The Bidder/ Contractor" which expression unless repugnant to the context or meaning hereof shall include its successors or assigns of the OTHER PART

Preamble

The Principal intends to award, under laid-down organizational procedures, contract/s for _____

_____ (hereinafter referred to as "Contract"). The Principal values full compliance with all relevant laws of the land, rules and regulations, and the principles of economic use of resources, and of fairness and transparency in its relations with its Bidder(s)/ Contractor(s).

In order to achieve these goals, the Principal will appoint panel of Independent External Monitor(s) (IEMs), who will monitor the tender process and the execution of the contract for compliance with the principles mentioned above.

Section 1- Commitments of the Principal

- 1.1 The Principal commits itself to take all measures necessary to prevent corruption and to observe the following principles: -
 - 1.1.1 No employee of the Principal, personally or through family members, will in connection with the tender for, or the execution of a contract, demand, take a promise for or accept, for self or third person, any material or immaterial benefit which the person is not legally entitled to.
 - 1.1.2 The Principal will, during the tender process treat all Bidder(s) with equity and reason. The Principal will in particular, before and during the tender process, provide to all Bidder(s) the same information and will not provide to any Bidder(s) confidential/ additional information through which the Bidder(s) could obtain an advantage in relation to the tender process or the contract execution.
 - 1.1.3 The Principal will exclude from the process all known prejudiced persons.
- 1.2 If the Principal obtains information on the conduct of any of its employees which is a penal offence under the Indian Penal Code 1860 and Prevention of Corruption Act 1988 or any other statutory penal enactment, or if there be a substantive suspicion in this regard, the Principal will inform its Vigilance Office and in addition can initiate disciplinary actions.

Section 2 - Commitments of the Bidder(s)/ Contractor(s)

- 2.1 The Bidder(s)/ Contractor(s) commit himself to take all measures necessary to prevent corruption. The Bidder(s)/ Contractor(s) commits himself to observe the following principles during participation in the tender process and during the contract execution.

- 2.1.1 The Bidder(s)/ Contractor(s) will not, directly or through any other person or firm, offer, promise or give to the Principal or to any of the Principal's employees involved in the tender process or the execution of the contract or to any third person any material, immaterial or any other benefit which he/ she is not legally entitled to, in order to obtain in exchange any advantage of any kind whatsoever during the tender process or during the execution of the contract.
- 2.1.2 The Bidder(s)/ Contractor(s) will not enter with other Bidder(s) into any illegal or undisclosed agreement or understanding, whether formal or informal. This applies in particular to prices, specifications, certifications, subsidiary contracts, submission or non-submission of bids or any other actions to restrict competitiveness or to introduce cartelization in the bidding process.
- 2.1.3 The Bidder(s)/ Contractor(s) will not commit any penal offence under the relevant Indian Penal Code (IPC) and Prevention of Corruption Act; further the Bidder(s)/ Contractor(s) will not use improperly, for purposes of competition or personal gain, or pass on to others, any information or document provided by the Principal as part of the business relationship, regarding plans, technical proposals and business details, including information contained or transmitted electronically.
- 2.1.4 Foreign Bidder(s)/ Contractor(s) shall disclose the name and address of agents and representatives in India and Indian Bidder(s)/ Contractor(s) to disclose their foreign principals or associates. The Bidder(s)/ Contractor(s) will, when presenting his bid, disclose any and all payments he has made, and is committed to or intends to make to agents, brokers or any other intermediaries in connection with the award of the contract.
- 2.2 The Bidder(s)/ Contractor(s) will not instigate third persons to commit offences outlined above or be an accessory to such offences.
- 2.3 The Bidder(s)/ Contractor(s) shall not approach the Courts while representing the matters to IEMs and shall await their decision in the matter.

Section 3 - Disqualification from tender process and exclusion from future contracts

If the Bidder(s)/ Contractor(s), before award or during execution has committed a transgression through a violation of Section 2 above, or acts in any other manner such as to put his reliability or credibility in question, the Principal is entitled to disqualify the Bidder(s)/ Contractor(s) from the tender process, terminate the contract, if already awarded, exclude from future business dealings and/ or take action as per the separate "Guidelines on Banning of Business dealings with Suppliers/ Contractors", framed by the Principal.

Section 4 - Compensation for Damages

- 4.1 If the Principal has disqualified the Bidder (s) from the tender process before award / order acceptance according to Section 3, the Principal is entitled to demand and recover the damages equivalent to Earnest Money Deposit/ Bid Security.
- 4.2 If the Principal is entitled to terminate the Contract according to Section 3, or terminates the Contract in application of Section 3 above, the Bidder(s)/ Contractor (s) transgression through a violation of Section 2 above shall be construed breach of contract and the Principal shall be entitled to demand and recover from the Contractor an amount equal to 5% of the contract value or the amount equivalent to Security Deposit/ Performance Bank Guarantee, whichever is higher, as damages, in addition to and without prejudice to its right to demand and recover compensation for any other loss or damages specified elsewhere in the contract.

Section 5 - Previous Transgression

- 5.1 The Bidder declares that no previous transgressions occurred in the last 3 (three) years with any other company in any country conforming to the anti-corruption approach or with any other Public Sector Enterprise in India that could justify his exclusion from the tender process.
- 5.2 If the Bidder makes incorrect statement on this subject, he can be disqualified from the tender process or the contract, if already awarded, can be terminated for such reason or action can be taken as per the separate "Guidelines on Banning of Business dealings with Suppliers/ Contractors", framed by the Principal.

Section 6 - Equal treatment of all Bidder (s)/ Contractor (s) / Sub-contractor (s)

- 6.1 The Principal will enter into Integrity Pacts with identical conditions as this Integrity Pact with all Bidders and Contractors.
- 6.2 In case of Sub-contracting, the Principal Contractor shall take the responsibility of the adoption of Integrity Pact by the Sub-contractor(s) and ensure that all Sub-contractors also sign the Integrity Pact.
- 6.3 The Principal will disqualify from the tender process all Bidders who do not sign this Integrity Pact or violate its provisions.

Section 7 - Criminal Charges against violating Bidders/ Contractors /Subcontractors

If the Principal obtains knowledge of conduct of a Bidder, Contractor or Subcontractor, or of an employee or a representative or an associate of a Bidder, Contractor or Subcontractor which constitutes corruption, or if the Principal has substantive suspicion in this regard, the Principal will inform the Vigilance Office.

Section 8 -Independent External Monitor(s)

- 8.1 The Principal appoints competent and credible panel of Independent External Monitor (s) (IEMs) for this Integrity Pact. The task of the IEMs is to review independently and objectively, whether and to what extent the parties comply with the obligations under this Integrity Pact.
- 8.2 The IEMs are not subject to instructions by the representatives of the parties and performs his functions neutrally and independently. He reports to the CMD, BHEL.
- 8.3 The IEMs shall be provided access to all documents/ records pertaining to the Contract, for which a complaint or issue is raised before them as and when warranted. However, the documents/records/information having National Security implications and those documents which have been classified as Secret/Top Secret are not to be disclosed.
- 8.4 The Principal will provide to the IEMs sufficient information about all meetings among the parties related to the Contract provided such meetings could have an impact on the contractual relations between the Principal and the Contractor. The parties offer to the IEMs the option to participate in such meetings.

- 8.5 The advisory role of IEMs is envisaged as that of a friend, philosopher and guide. The advice of IEMs would not be legally binding and it is restricted to resolving issues raised by a Bidder regarding any aspect of the tender which allegedly restricts competition or bias towards some Bidders. At the same time, it must be understood that IEMs are not consultants to the Management. Their role is independent in nature and the advice once tendered would not be subject to review at the request of the organization.
- 8.6 For ensuring the desired transparency and objectivity in dealing with the complaints arising out of any tendering process or during execution of Contract, the matter should be examined by the full panel of IEMs jointly, who would look into the records, conduct an investigation, and submit their joint recommendations to the Management.
- 8.7 The IEMs would examine all complaints received by them and give their recommendations/ views to the CMD, BHEL at the earliest. They may also send their report directly to the CVO, in case of suspicion of serious irregularities requiring legal/ administrative action. Only in case of very serious issue having a specific, verifiable Vigilance angle, the matter should be reported directly to the Commission. IEMs will tender their advice on the complaints within 30 days.
- 8.8 The CMD, BHEL shall decide the compensation to be paid to the IEMs and its terms and conditions.
- 8.9 IEMs should examine the process integrity, they are not expected to concern themselves with fixing of responsibility of officers. Complaints alleging mala fide on the part of any officer of the Principal should be looked into by the CVO of the Principal.
- 8.10 If the IEMs have reported to the CMD, BHEL, a substantiated suspicion of an offence under relevant Indian Penal Code / Prevention of Corruption Act, and the CMD, BHEL has not, within reasonable time, taken visible action to proceed against such offence or reported it to the Vigilance Office, the IEMs may also transmit this information directly to the Central Vigilance Commissioner, Government of India.
- 8.11 After award of work, the IEMs shall look into any issue relating to execution of Contract, if specifically raised before them. As an illustrative example, if a Contractor who has been awarded the Contract, during the execution of Contract, raises issue of delayed payment etc. before the IEMs, the same shall be examined by the panel of IEMs. Issues like warranty/ guarantee etc. shall be outside the purview of IEMs.
- 8.12 However, the IEMs may suggest systemic improvements to the management of the Principal, if considered necessary, to bring about transparency, equity and fairness in the system of procurement.
- 8.13 The word 'Monitor' would include both singular and plural.

Section 9 - Pact Duration

- 9.1 This Integrity Pact shall be operative from the date this Integrity Pact is signed by both the parties till the final completion of contract for successful Bidder, and for all other Bidders 6 months after the Contract has been awarded. Any violation of the same would entail disqualification of the bidders and exclusion from future business dealings.
- 9.2 If any claim is made/ lodged during currency of this Integrity Pact, the same shall be binding and continue to be valid despite the lapse of this Pact as specified above, unless it is discharged/ determined by the CMD, BHEL.

Section 10 - Other Provisions

- 10.1 This Integrity Pact is subject to Indian Laws and exclusive jurisdiction shall be of the competent Courts as indicated in the Tender or Contract, as the case may be.
- 10.2 Changes and supplements as well as termination notices need to be made in writing.
- 10.3 If the Bidder(s)/ Contractor(s) is a partnership or a consortium or a joint venture, this Integrity Pact shall be signed by all partners of the partnership or joint venture or all consortium members.
- 10.4 Should one or several provisions of this Integrity Pact turn out to be invalid, the remainder of this Integrity Pact remains valid. In this case, the parties will strive to come to an agreement to their original intentions.
- 10.5 Only those bidders / contractors who have entered into this Integrity Pact with the Principal would be competent to participate in the bidding. In other words, entering into this Integrity Pact would be a preliminary qualification.
- 10.6 In the event of any dispute between the Principal and Bidder(s)/ Contractor(s) relating to the Contract, in case, both the parties are agreeable, they may try to settle dispute through Mediation before the panel of IEMs in a time bound manner. In case, the dispute remains unresolved even after mediation by the panel of IEMs, either party may take further action as the terms & conditions of the Contract. The fees/expenses on dispute resolution through mediation shall be shared by both the parties. Further, the mediation proceedings shall be confidential in nature and the parties shall keep confidential all matters relating to the mediation proceedings including any settlement agreement arrived at between the parties as outcome of mediation. Any views expressed, suggestions, admissions or proposals etc. made by either party in the course of mediation shall not be relied upon or introduced as evidence in any further arbitral or judicial proceedings, whether or not such proceedings relate to the dispute that is the subject of mediation proceedings. Neither of the parties shall present IEMs as witness in any Alternative Dispute Resolution or judicial proceedings in respect of the dispute that was subject of mediation.

 For & On behalf of the Principal
 (Office Seal)

 For & On behalf of the Bidder/ Contractor
 (Office Seal)

Place _____
 Date _____

Witness: _____
 (Name & Address) _____

Witness: _____
 (Name & Address) _____



BHARAT HEAVY ELECTRICALS LIMITED

HEEP-HARIDWAR, UTTARAKHAND (249403)

General Instructions and Standard Terms & Conditions for bidding against Tender Enquiry (GISTC)

For Indian Bidders (Version June-2021, Rev: 06)

Table of Contents

1. GENERAL	1
2. ORIGIN OF QUOTATION	1
3. SUBMISSION OF TENDER	1
4. TENDER OPENING	2
5. SPECIFICATION, DRAWINGS & STANDARD	2
6. PRICE SCHEDULE	3
7. REVERSE AUCTION	3
8. DELIVERY TERMS	3
9. LD FOR LATE DELIVERY	4
10. PAYMENT TERMS	4
11. TAXES & DUTIES	5
12. BANK GUARANTEE	6
13. GUARANTEE / WARRANTY AND CORRESPONDING REPAIRS / REPLACEMENT OF GOODS	6
14. QUALITY REQUIREMENT	6
15. VALIDITY	6
16. RIGHT OF ACCEPTANCE	6
17. TRANSIT INSURANCE	7
18. RISK PURCHASE	7
19. FORCE MAJEURE CLAUSE	7
20. NON-DISCLOSURE AGREEMENT	8
21. SETTLEMENT OF DISPUTES / ARBITRATION	8
22. WHARFAGE / DEMURRAGE RESPONSIBILITY	8
23. CONDITIONS FOR AVAILING MICRO & SMALL ENTERPRISES (MSE'S) BENEFITS	8
24. INFORMATION TO THE BIDDERS	10
25. MAKE IN INDIA (GOVT-NOTIFICATION)	10
26. RESTRICTIONS UNDER RULE 144(XI) OF THE GENERAL FINANCIAL RULES (GFRs), 2017	12

27. NOTE..... 12

1. GENERAL.

These general terms & conditions shall apply to all the Tender Enquiries, notice inviting tenders, request for quotations concerning the supply of goods and / or rendering of services to Bharat Heavy Electricals Ltd., HEEP, Haridwar (hereinafter referred to as BHEL or the Purchaser). In case of placement of order these conditions will become part of Purchase Order (P.O) until unless the deviations are specifically agreed by BHEL.

2. ORIGIN OF QUOTATION.

- a) The quotation should preferably be from the principal bidder. However tender specific authorized registered dealer/agent can also submit the bid on their behalf, failing which the quotation is liable to be ignored. BHEL prefers to deal directly with the principal manufacturers.
- b) An agent cannot quote on behalf of more than one principal in the same Tender Enquiry.

3. SUBMISSION OF TENDER.

- a) Bid / Quotation must be enclosed in sealed cover on which tender enquiry number and the due date MUST BE written and be invariably sent under REGISTERED POST / SPEED POST / COURIER / Dropped in the Tender Box: addressed as follows:

Quotation against Enquiry No. _____

Dated: _____

Due on: _____

To,

**THE HEAD OF MATERIALS MANAGEMENT,
Heavy Electrical Equipment Plant,
Bharat Heavy Electricals Limited,
HARIDWAR-249403 (Uttarakhand), INDIA.**

- b) TENDER ROOM is located at: Room No. - 415, 4th Floor, Main Admin. Building, BHEL-HEEP, Haridwar.

Quotations / Bids not in accordance with General Instructions and Standard Terms & Conditions are likely to be ignored.



BHARAT HEAVY ELECTRICALS LIMITED

HEEP-HARIDWAR, UTTARAKHAND (249403)

General Instructions and Standard Terms & Conditions for bidding against Tender Enquiry (GISTC)

For Indian Bidders (Version June-2021, Rev: 06)

- c) In case of Three / Two Part Bid, technical bid containing technical offer, duly signed and un-priced copy of the Price Bid should be kept in one envelope. Price Bid containing only the price should be kept in a separate envelope. All envelopes indicating Part-1 or Part-2 or Part-3 as the case may be to be put in a bigger envelope. Please note that un-priced bid should be the exact replica of price bid but without prices.
- d) The bid / quotation must be posted before due date, keeping allowance for postal transit time. Quotations sent by any mode but not received in time will be ignored. Tender received through authorized E-mail is also acceptable. However, in time submission of tender in tender box shall be the responsibility of the bidder, sent through any mode. Documents submitted with the offer / bid shall be signed and stamped in each page by authorized representative of the bidder.
- e) Any additional documents submitted by supplier / bidder, during processing of registration application / tender or after placement of order shall not be accepted unless it is submitted with forwarding letter and duly signed and stamped.
- f) The bids of the bidders who are on the banned list and also the bids of the bidders, who engage the services of the banned firms, shall be rejected. The cutting / overwriting in the bid / offer must be duly attested by the signatories to the bid. The list of firms banned by BHEL is available on BHEL web site www.bhel.com.
- g) Being PMD vendor, if you are not quoting against this tender enquiry, please send your regret letter positively for our reference with valid reasons for not participating in the tender enquiry. Repeated lack of response on the part of bidder may lead to deletion such PMD vendor from BHEL's approved vendor list.
- h) The bidders will submit Integrity Pact, duly signed by its authorized signatory, along with their bids wherever estimated tender value is Rs. 2 Crore or more.
- i) In case of open tender, technically qualified unregistered bidders may apply online for registration through <http://www.bhel.com/index.php/vender>.
- j) BHEL reserves the right to award tendered quantities among more than one bidder (after acceptance of L1 price by the other bidders). BHEL can also consider awarding of part of the tendered quantity to other than L-1 bidder at L1 counter offered rates, if the quantity offered by the L-1 bidder is less than the quantity tendered for.
- k) In case of e-Tendering (Online bidding through e-portal), offline bid submitted in hard copy or in any other form by the vendor / supplier will not be accepted and will be rejected out rightly. Only e-portal bid will be accepted.

4. TENDER OPENING.

Tender opening is scheduled to start in the Tender Room at 2:00 PM, on the due date. Therefore, bid / quotations must reach this office / tender Box latest by 1:45 PM on due date. Only participating bidders are allowed to attend tender opening. **TENDERS RECEIVED AFTER THE SPECIFIED TIME OF THEIR 'SUBMISSION' WILL BE TREATED AS LATE TENDERS AND SHALL NOT BE CONSIDERED UNDER ANY CIRCUMSTANCES.** The bidders or their authorized representatives may be allowed to attend tender opening if duly authorized by their principals, through a tender specific letter on that particular day. General authorization letter is not acceptable.

Note: - Foreign bidders willing to attend the bid opening has to provide the requisite documents to the concerned Purchase executives for arranging gate pass for them.

5. SPECIFICATION, DRAWINGS & STANDARD.

- a) Bidders must give their detailed specification in the quotation along with relevant technical literature / catalogue etc. against the tender enquiry.
- b) The Bid should be accompanied with relevant copies of catalogues, drawings or specification as per tender enquiry.

Quotations / Bids not in accordance with General Instructions and Standard Terms & Conditions are likely to be ignored.



BHARAT HEAVY ELECTRICALS LIMITED

HEEP-HARIDWAR, UTTARAKHAND (249403)

General Instructions and Standard Terms & Conditions for bidding against Tender Enquiry (GISTC)

For Indian Bidders (Version June-2021, Rev: 06)

If these documents are not furnished, the offer is liable to be rejected.

- c) Wherever national / international (N/IN) standards are referred, the latest N/IN standards are to be followed. Mention year & date of standard revision that shall be followed for the supply.
- d) All Drawings and Standards are proprietary of BHEL. It must not be used in anyway detrimental to the interest of BHEL or without permission of BHEL.

6. PRICE SCHEDULE.

- a) Kindly quote your prices in figures and words both. In case of any discrepancy in value, the prices quoted in words shall be considered for evaluation and establishing L1 status.
- b) Prices quoted should not be more than the prices quoted to any other BHEL units / offices / divisions. Vendor to submit copy of latest Purchase Order placed by any unit of BHEL for similar items in the technical bid. In case no order has been placed on such items, specific confirmation that no order has been placed on such items should be provided.
- c) Prices should be quoted on F.O.R. Destination basis. Transit insurance shall be arranged by BHEL and not to be included in the prices. The offers quoted on other than F.O.R destination basis may result in non-consideration of such bids.
- d) In case BHEL accepts the EX-Works prices, such offers will be loaded by 1.5% of EX-Works value towards freight or with actual freight charges as per BHEL freight rate contract whichever is higher.
- e) In case of Indigenous items covered by DGS & D Rate Contract, the bidders should submit latest valid copy of the rate contract along with bid / quotation
- f) Applicable **IGST / CGST / SGST** and any other statutory levy should be indicated separately and clearly in the bid / quotation.

- g) Bidders can dispatch goods through any Indian Bank Association approved transporters having their branch at HARIDWAR / destination. If material is dispatched through other than Indian Bank Association approved transporter, material to be delivered on door delivery BHEL Stores basis.
- h) In case of dispatch of material through any other unapproved transporter, payment shall be made only after receipt of material and any additional charges payable to the transporter shall be to the bidder's account.
- i) Any demurrage / godown rent payable to the transporter / or to godown's owner due to any delay attributed by the supplier shall be recovered from supplier's account.
- j) Currency of Evaluation shall be INR.

NB: Financial evaluation of L1, L2Status will be on the basis of Landed Cost to BHEL.

7. REVERSE AUCTION.

Wherever RA is declared in the special terms and conditions of tender enquiry, following shall be applicable and Bidders to confirm the same:

"BHEL shall be resorting to Reverse Auction (RA) (Guidelines as available on www.bhel.com) for this tender. RA shall be conducted among all the techno-commercially qualified bidders.

Price bids of all techno-commercially qualified bidders shall be opened and same shall be considered as initial bids of bidders in RA. In case any bidder(s) do(es) not participate in online Reverse Auction, their sealed envelope price bid along with applicable loading, if any, shall be considered for ranking."

8. DELIVERY TERMS.

- a) Goods shall be delivered on 'FOR Destination' basis to the named destination unless otherwise called for in the tender enquiry.
- b) Loading on account of 3rd party inspection charges in case of Indian bidders shall be 0.20%.



BHARAT HEAVY ELECTRICALS LIMITED

HEEP-HARIDWAR, UTTARAKHAND (249403)

General Instructions and Standard Terms & Conditions for bidding against Tender Enquiry (GISTC)

For Indian Bidders (Version June-2021, Rev: 06)

9. LIQUIDATED DAMAGES (LD) FOR LATE DELIVERY.

a) Where items of Purchase Order are independently usable.

Liquidated Damages (LD) for Late Deliveries shall be applicable @0.5% per week or part thereof on the value of respective delayed supplies subject to a maximum of 10% of the value of respective delayed supplies. Value of delayed supplies will mean the Gross Value payable to the vendor (Before LD) against such supplies excluding taxes and duties.

b) Where the total items are required for a main equipment and items are interdependent.

Liquidated Damages (LD) for Late Deliveries shall be applicable @0.5% per week or part thereof on total value of Purchase Order subject to maximum of 10% of the total value of Purchase Order. Purchase Order value for this purpose shall be the Total Gross Value payable to the vendor (Before LD) excluding taxes and duties.

c) Bidders are requested to quote the best delivery meeting the delivery requirements. BHEL reserves the right to reject the offers not meeting BHEL's delivery requirement.

d) Commencement of delivery period shall be reckoned from the date of PO / LOI or any other agreed milestone.

e) Bidder shall deliver the goods in the manner and schedule agreed under the terms and conditions of Purchase order.

f) DELIVERY IN CASE OF REJECTION: In case the material is rejected, then date of replacement will be considered as the actual date of delivery.

g) DELIVERY AGAINST BANK DOCUMENTS: In case payment terms quoted by bidder are documents through bank, and the delivery terms being "FOR Haridwar / FOR Transporter Go-down" then date of delivery will be date of intimation by transporter / bidder of delivery of material at Haridwar for the LD purpose.

h) Where the payments are through bank, the documents may be presented for negotiation to BHEL authorized / nominated bank.

i) Payment of Liquidated Damages (LD) shall not in any way relieve the vendor from any of its obligations & liabilities under the contract.

10. PAYMENT TERMS.

a) BHEL's standard payment term is Payment after receipt and acceptance of materials / items at HEEP, BHEL-Store or at desired destination unless otherwise specified in Special Terms attached to the tender enquiry.

b) BHEL reserves the right to accept or reject the offer of the bidder who quotes the payment term other than BHEL's standard payment term.

c) Loading on account of deviation in payment terms shall be done as per extant rules of BHEL-Haridwar.

d) 100% payment along with taxes, freight & insurance will be made after receipt and acceptance of material and within 75 days from the date of invoice subject to submission of non-discrepant documents within 15 days of supply as per terms and conditions of Purchase Order. In case any discrepancy found in the documents, BHEL will notify the same to vendor within 7 days of receipt. Vendor has to clear all the discrepancies in one go within 7 days thereafter else the payment of vendor may get delayed.

e) For MSEs (covered under MSME Act) which are registered and periodically renewed with BHEL, the payment will be made within 45 days or as prescribed in the relevant act.

f) Adherence to the above time schedule of payment is contingent upon Vendor complying with GST Rules w.r.t availment of Input Tax Credit by BHEL.

g) In case GST credit is delayed / denied to BHEL, due to non / delayed receipt of goods and / or tax invoice or expiry of the timeline prescribed in GST Law for availing such ITC, or any other reason not attributable to BHEL, GST amount shall be recoverable from Vendor along with interest levied / leviable on BHEL.

h) The taxes and duties that are reimbursed would be the ones applicable as on the contractual Purchase order delivery date or the amount actually paid whichever is less.

Quotations / Bids not in accordance with General Instructions and Standard Terms & Conditions are likely to be ignored.



BHARAT HEAVY ELECTRICALS LIMITED

HEEP-HARIDWAR, UTTARAKHAND (249403)

General Instructions and Standard Terms & Conditions for bidding against Tender Enquiry (GISTC)

For Indian Bidders (Version June-2021, Rev: 06)

i) **The loading criteria for the different payment terms shall be as under;**

Payment Terms	Days of Loading
After Receipt & Acceptance of material within 75 days of supply.	No Loading
Against Delivery at BHEL-Stores Haridwar.	45
Against documents through bank (CAD):	45
Letter of Credit (LC)	120
Usance LC	No Loading if usance period is > 120 Days.
	Loading of days' difference i.e. difference between 120 days and usance period if the usance period is < 75 days.
Advance	Delivery Period + 120 Days - Advance Payment Days.

11. TAXES & DUTIES.

- a) The bidder to specify in their offer (part 1 bid) the category of their registration under GST like Registered, Unregistered and composite dealer.
- b) The provisional GST registration number of Bharat Heavy Electrical Ltd, Heavy Electricals Equipment Plant, Ranipur, Haridwar is "05AAACB4146P1ZL" with state Code as "05" and State Name as "Uttarakhand".
- c) Please quote our provisional GST registration number in all invoices raised for supply of goods and services under GST regime and also ensure filing of timely return and payment of tax and compliance of other applicable provisions on supplier under GST regime.
- d) No GST will be reimbursed to unregistered or composite dealer. In the event, any GST is quoted by composite dealer, the same shall be added to the cost of supply in evaluating the bid.
- e) Since, input credit of GST will be available to BHEL-Haridwar only after correct filing of return and payment of applicable GST by supplier, reimbursement of GST shall be made by

BHEL-Haridwar on matching of vendor inputs at GST portal, ensuring availability of input credit to BHEL Haridwar. Payment of GST will be made to vendor after matching of input credit and vendor to ensure submission of their invoices along with consent to accept payment of tax after such matching in all cases where bills are submitted directly to BHEL-Haridwar or through bank or under LC or through any other mode.

- f) In the event of any disallowance of input credit or applicability of interest or any other financial liability arises on BHEL-Haridwar due to any default of supplier under GST, such implication shall be to supplier's account.
- g) In the event of any change in the status of the vendor after the submission of the bid but before the supply, GST applicable at the time of supply or in the bid, based on the registration status of the vendor, whichever is lower shall be payable.
- h) Where ever applicable If PAN (Permanent Account Number) of the recipient is not available, income tax is deductible either at the normal rate or at the rate of 20 percent, whichever is higher as per Section 206AA of Indian Income Tax Act 1961.
- i) The bidder shall clearly indicate HSN (*Harmonised System Nomenclature*) / SAC (*Service Accounting Code*), its description and applicable rate of GST for each item in his techno-commercial bid.
- j) Statutory Variation in Taxes & duties as applicable at the time of supply shall be payable. However, in the event of no change in law but bidder quoting certain tax structure in bid document which is lower than the applicable one, such amount shall be the maximum amount of tax that can be claimed by bidder.
- k) **IMPORTED GOODS OFFERED BY INDIAN BIDDERS AGAINST DEALER INVOICE:** Wherever the material being offered is imported, the bidder must quote the prices inclusive of IGST. The rate and value of IGST as included in the price must be indicated separately. In case quantum of IGST is not mentioned by the bidder the same will not be considered for



BHARAT HEAVY ELECTRICALS LIMITED

HEEP-HARIDWAR, UTTARAKHAND (249403)

General Instructions and Standard Terms & Conditions for bidding against Tender Enquiry (GISTC)

For Indian Bidders (Version June-2021, Rev: 06)

evaluation. However, bidder will have to pass on the benefit of IGST to BHEL at the time supply.

- l) In case of directly dispatchable items to Customer's Site, BHEL-Haridwar will inform the GST registration number of the respective customer which must be mentioned on the vendor's invoice. Vendor to ensure availability of such information from BHEL-Haridwar before dispatch of any material. However, while filing GSTN-1, BHEL Haridwar GSTN number to be quoted.

Note: - Vendors must ensure compliance of all the applicable rules and procedure as envisaged in the GST Regime. Any loss to BHEL-Haridwar due to fault / non-compliance by the vendor will be to the vendor's account.

12. BANK GUARANTEE.

In case the bank guarantees are required to be deposited towards security deposit/performance guarantee or for any other purpose as per the terms of this tender enquiry, such bank guarantees of the requisite value in the denominated currency of the purchase order should be from one of the Indian branch of BHEL consortium banks and the bank guarantee should be in the proforma as prescribed by BHEL. The proforma of bank guarantee and the list of consortium banks are displayed at BHEL website www.bhelhwr.co.in. However, in case the bank guarantee is not from BHEL consortium banks, then the bidder has to get the bank guarantee confirmed from one of the Indian branch of BHEL consortium banks and the bank charges for such confirmation will be borne by the bidder.

13. GUARANTEE / WARRANTY AND CORRESPONDING REPAIRS / REPLACEMENT OF GOODS.

Goods shall comply with the specifications for material, workmanship and performance. Unless otherwise specified, the warranty shall be for a period of 18 months from the date of receipt. If the delivery is found non-compliant during the warranty period, leading to rejection, the Seller shall arrange free replacement / repair of goods, within one month from the date of intimation or any mutually agreed period. The rejected goods shall be taken away by the Seller at his cost and

replaced on Delivered Duty Paid (DDP) (FOR - BHEL Stores / designated destination basis) within such period. In the event of the Seller's failure to comply, Purchaser may take action as appropriate, including Repair / Replenish rejected goods & disposal of rejections, at the risk & cost of the Seller. In case the defects attributable to Seller are detected during processing of the goods at BHEL or at our subcontractor's works, the Seller shall be responsible for free replacement / repair of the goods as required by BHEL.

- b) **RETURN OF REJECTED MATERIAL FOR REPLACEMENT:** The bidder shall have to pay 5% incidental charges while taking back supplied material if it is found rejected on receipt. The rejected material shall be sent back only after receipt of replacement / submission of BG / refund of amount paid.

14. QUALITY REQUIREMENT.

Your bid / quotation should have specific confirmation regarding meeting all our quality requirements such as. (i) Test Certificate (TC), (ii) Guarantee Certificate (GC) / Warranty Certificate (WC), (iii) Quality Plan (QP) (if applicable); and (iv) Pre-Dispatch Inspection at your works (if applicable).

15. VALIDITY.

The quotation should be valid for a minimum period of 90 days effective from the date of opening of tender, unless otherwise specified in the tender enquiry.

16. RIGHT OF ACCEPTANCE.

- a) **BHARAT HEAVY ELECTRICALS LIMITED HARIDWAR** reserves the right to reject any or all the bids / quotations without assigning any reason thereof. BHEL also reserves the right to increase or decrease the tendered quantities. Bidders should be prepared to accept order for reduced quantity without any extra charges.
- b) Any discount / revised offer / bids submitted by a bidder on its own shall be considered, provided it is received on or before the due date and time of offer / bid submission (Part-1). Conditional discounts shall not be considered for evaluation of tenders.



BHARAT HEAVY ELECTRICALS LIMITED

HEEP-HARIDWAR, UTTARAKHAND (249403)

General Instructions and Standard Terms & Conditions for bidding against Tender Enquiry (GISTC)

For Indian Bidders (Version June-2021, Rev: 06)

- c) Unsolicited discounts / revised offers / bids given after Part-1 bid opening shall not be accepted. No change in price will be permitted within the validity period asked for in the tender enquiry.
- d) In case of changes in scope and / or technical specification and / or commercial terms & conditions having price implication, techno-commercially acceptable bidders shall be asked by BHEL to submit the impact of such changes on their price bids. In case a bidder opts to submit revised price bid instead of impact called for then the latest price bid shall prevail. However, in both situations, original price bid will be necessarily opened.
- e) The bidder whose bid is technically not accepted will be informed & EMD wherever submitted shall be returned after finalization of contract. EMD shall be forfeited in the event of bidder opting out after tender opening.
- f) BHEL reserves the right to short close the existing Purchase Order / Rate Contract / Work Order or any extension thereof at any stage.

17. TRANSIT INSURANCE.

- a) Transit Insurance will be covered by BHEL under its open Insurance Policy. Seller shall inform dispatch particulars (Purchase Order, RR /GR, Invoice value etc.) to "Finance department (Store bill Section), BHEL Ranipur, Haridwar (Uttarakhand-India) with value of consignment to the Purchaser within 07 days of dispatch for BHEL to arrange insurance coverage in its policy. Failure on the part of seller to inform dispatch particulars will make him liable to pay for any transit damages / losses suffered by the Purchaser.
- b) If Quoted Prices are inclusive of transit insurance, no weightage shall be given while evaluating the bids for Cost of Insurance, being in BHEL Scope.

18. RISK PURCHASE.

In case of abnormal delays (beyond the maximum late delivery period as per LD clause) in supplies / defective supplies or non-fulfillment of any other terms and conditions given in Purchase Order, BHEL may cancel the Purchase Order in full or part thereof, and may also make the purchase of such material from elsewhere / alternative source at the risk and cost of the supplier. BHEL will take all reasonable steps to get the material from alternate source at optimum cost. If bidder does not agree to the above Risk Purchase Clause, BHEL reserves the right to reject the offer. In case for compelling reasons BHEL accepts the offer without acceptance of this clause by the bidder and in the eventuality of Risk Purchase, appropriate action will be taken as per BHEL extant rules. This will be without prejudice to any other right of BHEL under the contract or under General Law.

19. FORCE MAJEURE CLAUSE.

Notwithstanding any other thing contained anywhere else in the contract or PO (Purchase Order), In case the discharge of obligation under the contract by either party is impeded or made unreasonably onerous, neither party shall be considered in breach of the contract to the extent that performance of their respective obligation is prevented by an event of Force Majeure that arises after the effective date (PO date).

In the above clause, Force Majeure means an event beyond the control of the parties to the contract which prevents a party from complying with any obligation of the contract including but not limited to:

- Act of God (Such as but not limited to earthquake, drought, tidal waves, floods etc.).
- War (whether war be declared or not), Hostilities Invasion, Act of foreign enemy etc.
- Rebellion, revolution, insurrection, civil war etc.
- Contamination of Radio Activity from any nuclear fuel or from any other nuclear waste or any other hazardous materials.
- Riots, commotions, strike unless restricted to the employees of supplier.
- Acts of terrorism.



BHARAT HEAVY ELECTRICALS LIMITED

HEEP-HARIDWAR, UTTARAKHAND (249403)

General Instructions and Standard Terms & Conditions for bidding against Tender Enquiry (GISTIC)

For Indian Bidders (Version June-2021, Rev: 06)

- g) Other unforeseeable circumstances beyond the control of the parties and which the affected party cannot avoid even by using its best efforts.
- h) Cancellation of contract by customer.
- i) Change in law / government. Regulation making the performance impossible.
- j) Pandemic or Epidemic.

The party claiming to be affected by force majeure shall notify the other party in writing immediately without delay on the intervention and on the cessation of such circumstances.

Irrespective of any extension of time, if an event of force majeure occurs and its effect continues for more than 180 days the affected party shall have right to cancel the contract.

As soon as reasonably practicable following the date of commencement of a Force Majeure Event, and within a reasonable time following the date of termination of a Force Majeure Event, either Party invoking it shall submit to the other Party reasonable proof of the nature of the Force Majeure Event and of its effect upon the performance of the Party's obligations under this Agreement.

The party shall, and shall ensure that its Subcontractors shall, at all times take all reasonable steps within their respective powers and consistent with Good Operating Practices (but without incurring unreasonable additional costs) to:

- a) Prevent Force Majeure Events affecting the performance of the party's obligations under this Agreement.
- b) mitigate the effect of any Force Majeure Event and
- c) Comply with its obligations under this Agreement.

If the war like situation has developed in a country where a seller's works is located in this P.O. or there is political instability and Indian Embassy located in that country forbids or advises for not having any business dealing with the sellers located in such zone / region/ country, then BHEL reserves the right to cancel the order.

20. NON-DISCLOSURE AGREEMENT.

All Drawing and Technical Documents relating to the product or it's manufacture submitted by one party to the other, prior or

subsequent to the formation of contract, shall remain property of the submitting party. Drawing, technical documents or other technical information received by one party, shall not without the consent of the other party, be used for any other purpose than that, for which they were provided. Such technical information shall not without the consent of the submitting party, otherwise be used or copied, reproduced, transmitted or communicated to a third party. Patterns supplied by BHEL will remain BHEL's property which shall be returned by the bidder on demand to BHEL. Bidder shall in no way share or use such intellectual property of BHEL to promote his own business with others or to gain a commercial advantage. BHEL reserves the right to claim damages from the bidder, or take appropriate action as deemed fit against the bidder, for any infringement of the provisions contained herein as available under law or equity.

21. SETTLEMENT OF DISPUTES / ARBITRATION.

In case of any dispute arising out of as in connection with this contract, the same shall be referred to arbitration under Arbitration & Conciliation Act 1996 of a sole arbitrator who shall be appointed by mutual consent of the parties. The seat & venue of arbitration shall be Haridwar.

The proceedings shall be conducted in English. The Governing law of contract shall be the substantive law of India.

22. WHARFAGE / DEMURRAGE RESPONSIBILITY.

In the event of delay in receipt of documents by Manager (Stores-Shipping) BHEL-Haridwar and in case where dispatches are made through Unapproved Transporter the sole responsibility for wharfage / demurrage for such delay shall be that of supplier.

23. CONDITIONS FOR AVAILING MICRO & SMALL ENTERPRISES (MSE'S) BENEFITS.

- a) "MSE Suppliers can avail the intended benefits only if they submit along with the offer, attested copies of either EM II certificate having deemed validity (**five years** from the date of issue of acknowledgement in EM II) or valid NSIC certificate or EM II certificate along with attested copy of a CA certificate



BHARAT HEAVY ELECTRICALS LIMITED

HEEP-HARIDWAR, UTTARAKHAND (249403)

General Instructions and Standard Terms & Conditions for bidding against Tender Enquiry (GISTC)

For Indian Bidders (Version June-2021, Rev: 06)

(Format enclosed at annexure-1 where deemed validity of EM II certificate of five years has expired) applicable for the relevant financial year (latest audited). Date to be reckoned for determining the deemed validity will be the date of bid opening (Part 1 in case of two-part bid) or vendor has to give Udyog Adhar Memorandum (UAM). Non submission of such documents will lead to consideration of their bid at par with other bidders. No benefit shall be applicable for this enquiry if any deficiency in the above required documents is found or the requisite documents are not submitted before price bid opening. If the tender is to be submitted through e-procurement portal, then the above require document are to be uploaded on the portal. Documents should be notarized or attested by a Gazetted officer. **UAM need not required to be notarized or attested.**

b) Any new supplier will be eligible for registration with BHEL as MSE supplier provided at least any one of the following documents are submitted along with application for registration: -

1. Udyog Adhar Memorandum (UAM).
2. Valid National Small Industries Commission (NSIC) Certificate.
3. Entrepreneurs Memorandum part II (EM II) certificate (valid based on deemed validity of 5 years) or
4. EM II certificate along with attested copy of CA Certificate (as per prescribed format at annexure-A) applicable for the relevant financial year (latest audited), where the deemed validity of EM II is over.
5. However, credentials of all MSE suppliers will be verified before advancing the intended benefits.
6. MSE bidders claiming SC/ST status will have to submit SC/ST certificate of the Proprietor from competent authority. Attested (notarized or attested by Gazetted officer) copy to be submitted along with the offer.
7. In case techno-commercial accepted bidders include MSE source and their prices (based on landed cost – considering quoted prices) are within the price band of 15% w.r.t. L-1 bidder, then BHEL can offer **25%** of quantity of respective item (rounded off to nearest number) to MSE bidders at L-1 price and in case, more than one MSE bidder is in 15 % band and the same is accepted by more than one MSE bidders then **25%** quantities of respective items will be considered for ordering on proportionate basis amongst MSE bidders.

8. There will be minimum of **3%** reservation for women owned MSEs within the above mentioned 25% reservation.
9. The reservation for MSEs owned by SC/ST will be **6.25%** { 25% out of target of 25% - refer para 4 of Public Procurement Policy for the Micro and Small Enterprises(MSEs)}.
10. The definition of MSEs owned by Women Entrepreneurs is clarified as under:
 - a) In case of proprietary MSE, proprietor shall be Woman.
 - b) In case of partnership MSE, the Woman partners shall be holding at least 51% of share in the unit.
 - c) In case of Private Limited companies, at least 51% share shall be held by Women promoters.
11. The definition of MSEs owned by SC/ST is clarified as under:
 - a) In case of proprietary MSE, proprietor(s) shall be SC/ST.
 - b) In case of partnership MSE, the SC/ST partners shall be holding at least 51% of shares in the unit.
 - c) In case of Private Limited companies, at least 51% share shall be held by SC/ST promoters.
12. While distributing the **25%** quantity amongst MSE bidders the decimal points in quantity shall be ignored for all the bidders except the L-1 amongst MSE bidders. Balance quantity after allocating the quantity to other MSE bidders ignoring the quantities in decimal, shall be given to L-1 (amongst MSE) bidder. However, if there are more than one MSE bidder at the same price level than preference for additional quantities due to ignoring off the decimal (as mentioned above) shall be given to the bidder offering favorable terms to BHEL and if the conditions offered are also same then preference will be given to the bidder having high SPR rating.
13. In case there are more than one MSE bidders (with different landed cost to BHEL) within 15% price band of lowest bidder and quantity to be offered is 1 no. only, then preference shall be given to the MSE bidder with lowest landed cost.
14. In case there are more than one MSE bidders (with same landed cost to BHEL) within 15% price band of lowest bidder and quantity to be offered is 1 no. only, then preference shall be given first, based on the favorable terms in the bid and in case terms are also same, the bidder with high SPR rating shall be given preference.
15. If L1 bidder is MSE bidder, entire quantity will be given to such MSE bidder only.



BHARAT HEAVY ELECTRICALS LIMITED

HEEP-HARIDWAR, UTTARAKHAND (249403)

General Instructions and Standard Terms & Conditions for bidding against Tender Enquiry (GISTIC)

For Indian Bidders (Version June-2021, Rev: 06)

16. Note: It may however be noted that MSE guidelines as on date (Date of Technical Bid Opening Part-1) shall prevail.

17. "As per the OM No. F.No. 1(2)(1)/2016-MA dtd. 09.02.2017 issued from the Office of Development Commissioner (Micro, Small & Medium Enterprises), "Traders and agents should not be allowed to avail the benefits extended under the PP Policy."

In view of this, it is clarified that benefits of MSE (such as EMD Waiver, Tender fee exemption, Price preference, Payment preference etc.) will be given only to those MSE Vendors who are manufacturers of offered items against the NIT. No MSE benefits shall be provided to Agents / Stockists / Dealers / Traders etc. for the items offered but not manufactured by themselves."

24. INFORMATION TO THE BIDDERS.

a) Purchase related information is available at our Business-to-Business (B2B) Portal available on our website <https://hwr.bhel.com>. The user ID & password can be obtained by sending a request to concerned purchase executives.

b) Intimate your change in mail address or communication address or changes, if any, by email to AGM (SDX/MM) giving your bidder Code.

c) Please resolve your rejections and unexecuted overdue purchase order immediately which are posted at our B2B Portal, which can be visited through our site <https://hwr.bhel.com>

d) Copy of this Tender Enquiry is being sent through the post.

e) The Bidder declares that they will not enter into any illegal or undisclosed agreement or understanding, whether formal or informal with other bidder(s). This applies in particular to prices, specifications, certifications, subsidiary contracts, submission or non-submission of bids or any other actions to restrict competitiveness or to introduce cartelization in the bidding process.

In case, the bidder is found having indulged in above activities, suitable action shall be taken by BHEL as per extant policies/guidelines.

f) Supplier must upload digitally signed e-Invoice on B2B portal for processing of Bills.

In other cases, inked signed hard copy of Invoice to be submitted for processing of Bills.

25. MAKE IN INDIA (GOVT-NOTIFICATION).

A. This tender enquiry shall be governed by notification no. P-45021/2/2017-PP (BE-II) dated 04.06.2020 of government of INDIA and subsequent circulars issued afterwards. Accordingly, the minimum local content, the margin of purchase preference and the procedure for preference to make in INDIA shall be adhered.

B. The margin of purchase preference shall be 20%.

- 'Class-I local Supplier' means a supplier or service provider, whose goods, services or works offered for procurement, has local content equal to or more than 50%, as defined under this order.
- 'Class-II local Supplier' means a supplier or service provider, whose goods, services or works offered for procurement, has local content more than 20% but less than 50%, as defined under this order.
- 'Non- local Supplier' means a supplier or service provider, whose goods, services or works offered for procurement, has local content less than or equal to 20%, as defined under this order.

C. Vendor to specifically confirm if they are Class-I or Class-II local supplier or not as per above mentioned notification. Accordingly, the 'Class-I local supplier' / 'Class-II local Supplier' at the time of tender, bidding or solicitation shall be required to indicate percentage of local content and provide self-certification that the item offered meets the local content requirement for 'Class-I local supplier' / 'Class-II local Supplier', as the case may be. They shall also give details of the location(s) at which the local value addition is made.

D. In cases of Procurement for a Value in Excess of Rs. 10 Crores, the 'Class-I local supplier' / 'Class-II local Supplier' shall be required to provide a Certificate from the Statutory Auditor or Cost Auditor of the Company (in the case of companies) or from a practicing Cost Accountant or practicing Chartered Accountant (in respect of suppliers other than companies) giving the percentage of Local Content.



BHARAT HEAVY ELECTRICALS LIMITED

HEEP-HARIDWAR, UTTARAKHAND (249403)

General Instructions and Standard Terms & Conditions for bidding against Tender Enquiry (GISTC)

For Indian Bidders (Version June-2021, Rev: 06)

E. Requirement of Purchase Preference:

Purchase preference shall be given to 'Class-I local supplier' in procurements undertaken by procuring entities in the manner specified hereunder -

a. In the procurements of goods or works, which are covered by para 3(b) of mentioned Govt. circular and which are divisible in nature, the 'class-I local supplier' shall get purchase preference over 'Class-II supplier' as well as 'Non-local supplier', as per following procedure:

- i. Among All qualified bids, the lowest bid will be termed as L1. If L1 is 'Class-I local supplier', the contract for full quantity will be awarded to L1.
- ii. If L1 bid is not a 'Class-I local supplier', 50% of the order quantity shall be awarded to L1. Thereafter, the lowest bidder among the 'Class-I local supplier' will be invited to match the L1 price for the remaining 50% quantity subject to the class-I local supplier's quoted price falling within the margin of purchase preference, and contract for that quantity shall be awarded to such 'Class-I local supplier' subject to matching the L1 price. In case such lowest eligible 'Class-I local supplier' fails to match the L1 price or accepts less than the offered quantity, the next higher 'Class-I local supplier' within the margin of purchase preference shall be invited to match the L1 price for remaining quantity and so on, and contract shall be awarded accordingly. In case some quantity is still left uncovered on Class-I local supplier, then such balance quantity may also be ordered on the L1 bidder".

b. In the procurements of goods or works, which are covered by para 3(b) of mentioned Govt. circular and which are not divisible in nature, and in procurement of services where the bid is evaluated on price alone, the 'class-I local supplier' shall get purchase preference over 'Class-II supplier' as well as 'Non-local supplier', as per following procedure:

- i. Among all qualified bids, the lowest bid will be termed as L1. If L1 is 'Class-I local supplier', the contract will be awarded to L1.
- ii. If L1 is not 'Class-I local supplier', the lowest bidder among the 'Class-I local supplier', will be invited to match the L1 price subject to Class-I local supplier's quoted price falling

within the margin of purchase preference, and the contract shall be awarded to such 'Class-I local supplier' subject to matching the L1 price.

- iii. In case such lowest eligible 'Class-I local supplier', fails to match the L1 price, the 'Class-I local supplier' with the next higher bid within the margin of purchase preference shall be invited to match the L1 price and so on and contract shall be awarded accordingly. In case none of the 'Class-I local supplier' within the margin of purchase preference matches the L1 prices, the contract may be awarded to the L1 bidder.

c. 'Class-II local supplier' will not get purchase preference in any procurement, undertaken by procuring entities.

F. For this procurement, the local content to categorize a supplier as a Class-I local supplier/ Class-II local supplier/ Non-local supplier and purchase preference to Class-I local supplier, is as defined in Public Procurement (Preference to Make in India), Order 2017 dated 04.06.2020 issued by DPIIT. In case of subsequent orders issued by nodal ministry, changing the definition of local content for the items of the NIT, the same shall be applicable even if issued after issue of this NIT, but before opening of Part-II bids against this NIT.

G. Procurements where estimated value to be procured is less than Rs. 5 lakhs shall be exempted from GOI order No. P-45021/2/2017-PP (BE-II) dated 04.06.2020.

H. For procurement of Goods & Services which are divisible in nature, following shall be operated for **MSE bidders** under Public procurement Policy for the Micro and Small Enterprises (MSEs) Amendment Order, 2019, Ref. No. AA:SSP: MSE: Amndt, dtd. 30.11.2018, Circular No. 44 of 2018-19;-

a. If L1 bid is not from "Class-I local Supplier" and price quoted by MSE bidder falls within the margin of Purchase preference (L1+15% for MSEs), then 25 % of total order quantity of respective item (rounded off to nearest number) shall be awarded to MSE bidder, subject to MSE bidder matching the L1 Price. Out of Remaining 75% quantity, distribution shall be operated as per below sub-clause (2) –

b. If "Class- I Local Supplier" (Next to L1, other than MSE) quoted price falling within the Margin of Purchase Preference, and "Class-I local supplier" matches the L1 price,



BHARAT HEAVY ELECTRICALS LIMITED

HEEP-HARIDWAR, UTTARAKHAND (249403)

General Instructions and Standard Terms & Conditions for bidding against Tender Enquiry (GISTC)

For Indian Bidders (Version June-2021, Rev: 06)

then 50% of remaining Quantity (after allocation of 25% to MSE) i.e. 37.5% shall be awarded to local supplier and 37.5% shall be awarded to foreign bidder.

Note: L1 Price refers to lowest evaluated / landed cost to Company.

For Further details, please refer GOI order no. P-45021 / 2 / 2017 - PP (BE-II) dated 04.06.2020.

26. RESTRICTIONS UNDER RULE 144(XI) OF THE GENERAL FINANCIAL RULES (GFRs), 2017

All provisions of Order No. F.No.6/18/2019-PPD of Department of Expenditure (DoE) shall be applicable for this tender enquiry (Order copy is available at <https://doe.gov.in/procurement-policy-divisions>). Accordingly, any bidder from a country which shares a land border with India (except the countries to which the Govt. of India has extended lines of credit or in which the Govt. of India is engaged in development projects for which list is available at <https://www.mea.gov.in/>) will be eligible to bid in this tender only if the bidder is registered with the Competent Authority as specified in Annex I of the said Order of DoE.

Updated list of the countries to which lines of credit have been extended or in which development projects are undertaken are available on the Ministry of External affairs website (<https://www.mea.gov.in/>)

For the purpose of this order, definition of Bidder from a country which shares a land border with India shall be same as defined in the Annex III of the said order.

Registration with the competent authority as stipulated in the said order is responsibility of bidder. Bidder has to submit a certificate certifying following along with offer:

"I have read the clause regarding restrictions on procurement from a bidder of a country which shares a land border with India; I certify that bidder (.... Name of Bidder) is not from such a country or, if from such a country, has been registered with the Competent Authority. I hereby certify that bidder (.....Name of bidder) fulfils all requirements in this regard and is eligible to be considered"

If the bidder is from such country which shares a land border with India evidence of valid registration by the Competent Authority shall also be attached along with offer."

27. NOTE.

- a) Special conditions of enquiry, if enclosed by BHEL, will supersede the respective standard / general terms of enquiry.
- b) Any other Standard terms and Conditions of the bidder attached / referred against the tender enquiry will be treated as null and void ab initio.
- c) In order to protect the commercial interests of BHEL, it becomes necessary to take action against suppliers / contractors by way of suspension of business dealings, who either fail to perform or are in default without any reasonable cause, cause loss of business / money / reputation, indulged in malpractices, cheating, bribery, fraud or any other misconducts or formation of cartel so as to influence the bidding process or influence the price etc. Guide- lines for Suspension of Business Dealings with Suppliers / Contractors shall prevail over which is available at BHEL website <http://www.bhel.com>
- d) The bidder along with its associate / collaborators / sub-contractors / sub-vendors / consultants / service providers shall strictly adhere to BHEL Fraud Prevention Policy displayed on BHEL website <http://www.bhel.com> and shall immediately bring to the notice of BHEL-Management about any fraud or suspected fraud as soon as it comes to their notice.
- e) "BHEL shall recover the amount of compensation paid to victim(s) by BHEL towards loss of life / permanent disability due to an accident which is attributable to the negligence of contractor, agency or firm or any of its employees as detailed below;
 1. **Victim:** Any person who suffers permanent disablement or dies in an accident as defined below.
 2. **Accident:** Any death or permanent disability resulting solely and directly from any unintended and unforeseen injurious

Quotations / Bids not in accordance with General Instructions and Standard Terms & Conditions are likely to be ignored.



BHARAT HEAVY ELECTRICALS LIMITED

HEEP-HARIDWAR, UTTARAKHAND (249403)

General Instructions and Standard Terms & Conditions for bidding against Tender Enquiry (GISTC)

For Indian Bidders (Version June-2021, Rev: 06)

occurrence caused during the manufacturing / operation and works incidental thereto at BHEL factories/ **offices and precincts** thereof , project execution , erection and commissioning, services, repairs and maintenance, trouble shooting, serving , overhaul, renovation and retrofitting , trial operation, performance guarantee testing undertaken by the company or during any works / during working at BHEL Units/ Offices/ townships and premises/ project sites.

3. Compensation in respect of each of the victims:

- (i) In the event of death or **permanent disability** resulting from **Loss of both limbs**: Rs. 10,00,000/- (Rs. Ten Lakh).
- (ii) In the event of **other permanent disability**: Rs. 7,00,000/- (Rs. Seven Lakh).

4. Permanent Disablement: A disablement that is classified as a permanent total disablement under the proviso to Section 2(l) of the Employees Compensation Act, 1923.”

f) The bidder shall be in compliance with applicable laws, rules and regulations throughout the terms of the contract for conducting its business generally and to perform its obligations under this contract.



COMBINED BILL OF MATERIAL

Printed On:12.09.2023

Printed By:

CBOM No: 01603170062 CBOM Var: 00 Revno: 49 Rev Date: 24.07.2019
Description: FRONT WATER BOX (TUR.SIDE) Total weight: 18465.0

RECORD OF CHANGES

Drawing No	Var	Revno	Rev Date	Description
01603170062	00	1	12.10.2011	Auto Revision 21603470040/00 31603170017/00; 31603170202/00 31603470025/00; 31603470027/00 31603470067/00; 31603470068/00 41603170009/00; 41603170032/00
01603170062	00	2	12.10.2011	Auto Revision 21603470040/00 31603170017/00; 31603170202/00 31603470025/00; 31603470027/00 31603470067/00; 31603470068/00 41603170009/00; 41603170032/00
01603170062	00	3	20.12.2011	MAIN ASSY. Wt. UPDATED
01603170062	00	4	21.12.2011	Auto Revision 31603170242/00
01603170062	00	5	23.12.2011	Auto Revision 21603170149/00
01603170062	00	6	23.12.2011	Auto Revision 21603170149/00
01603170062	00	7	17.01.2012	Auto Revision 21603170149/00
01603170062	00	8	17.01.2012	Auto Revision 21603170149/00
01603170062	00	9	10.02.2012	ASSLY UNIT & FABRICATED .Wt. UPDATED.
01603170062	00	10	13.02.2012	Auto Revision 31603170242/00
01603170062	00	11	13.02.2012	Auto Revision 31603170242/00
01603170062	00	12	13.02.2012	Auto Revision 31603170242/00
01603170062	00	13	11.03.2012	ITEM 22 REPLACED.
01603170062	00	14	13.03.2012	Auto Revision 31603470108/00
01603170062	00	15	13.03.2012	Auto Revision 31603470108/00
01603170062	00	16	13.03.2012	Auto Revision 31603470108/00
01603170062	00	17	13.03.2012	Auto Revision 31603470108/00
01603170062	00	18	13.03.2012	Auto Revision 31603470108/00
01603170062	00	19	17.07.2012	QUANTITY OF ITEM No.24 (ANGLE) CHANGED.
01603170062	00	21	29.08.2012	Auto Revision 21603170149/00
01603170062	00	22	05.12.2012	ITEM No. 31 BLANK SIZE & WT. CHANGED. ITEM No. 32 AND 33 REPLACED.
01603170062	00	23	19.12.2013	Auto Revision 21603470040/00
01603170062	00	24	07.01.2014	Auto Revision 31603170017/00

ENGG

WTX

	Initial	Date	Initial	Date
Worked By	hxebns	17.08.2011	wtxjk	11.10.2011
Checked By	hxeddt	11.10.2011	wtxhpr	11.10.2011
Approved By	hxemkl	12.10.2011	wtxhpr	11.10.2011



COMBINED BILL OF MATERIAL

Printed On:12.09.2023

Printed By:

CBOM No: 01603170062 CBOM Var: 00
Description: FRONT WATER BOX (TUR.SIDE)

Revno: 49

Rev Date: 24.07.2019

Total weight: 18465.0

RECORD OF CHANGES

Drawing No	Var	Revno	Rev Date	Description
01603170062	00	25	01.11.2014	Auto Revision 31603470108/00
01603170062	00	26	01.11.2014	Auto Revision 31603470108/00
01603170062	00	27	18.06.2015	ITEM NO. 24(ANGLE) REPLACED.
01603170062	00	28	05.11.2015	Auto Revision 31603470067/00
01603170062	00	29	05.11.2015	Auto Revision 31603470108/00
01603170062	00	30	07.11.2015	Auto Revision 31603470108/00
01603170062	00	31	17.02.2016	Auto Revision 31603470108/00
01603170062	00	32	17.02.2016	Auto Revision 31603470108/00
01603170062	00	33	05.05.2016	variant of item no.27 updated.
01603170062	00	34	12.05.2016	Auto Revision 31603170017/01
01603170062	00	35	12.05.2016	Auto Revision 31603170017/01
01603170062	00	36	12.05.2016	Auto Revision 31603170017/01
01603170062	00	37	22.12.2017	Auto Revision 31603470108/00
01603170062	00	38	05.09.2018	Auto Revision 41603170009/00
01603170062	00	39	24.06.2019	Auto Revision 24.8322.033/00
01603170062	00	40	24.06.2019	Auto Revision 24.8322.033/00
01603170062	00	41	24.06.2019	Auto Revision 24.8322.033/00
01603170062	00	42	22.07.2019	Auto Revision 31603170017/01
01603170062	00	43	22.07.2019	Auto Revision 31603170017/01
01603170062	00	44	22.07.2019	Auto Revision 31603170017/01
01603170062	00	45	22.07.2019	Auto Revision 31603170017/01
01603170062	00	46	24.07.2019	Auto Revision 31603170017/01
01603170062	00	47	24.07.2019	Auto Revision 31603170017/01
01603170062	00	48	24.07.2019	Auto Revision 31603170017/01
01603170062	00	49	24.07.2019	Auto Revision 31603170017/01

ENGG

WTX

Worked By	Initial	Date	Initial	Date
Checked By	Initial	Date	Initial	Date
Approved By	Initial	Date	Initial	Date



COMBINED BILL OF MATERIAL

Printed On:12.09.2023

Printed By:

CBOM No: 01603170062 **CBOM Var:** 00
Description: FRONT WATER BOX (TUR.SIDE)

Revno: 49

Rev Date: 24.07.2019

Total weight: 18465.0

Item No	Drawingno Var Mvar	Mat Code	Mat Spec	Weight	Blank Sizes	Nos	Qty	Norm/pc	Extra Norm	Total Norm
Qty(Total)	Description		Assy. Remarks	Inclusion?	Mat Shape		Remarks			
Typ Cat Zone	Var/Matl. Description		ENGG SIZE/GRP	Fab Wt	Route				Spare Code	Unit
0	01603170062 00			18465.0						
1(1)	FRONT WATER BOX (TUR.SIDE)		L12	Y						
MF CD			Y	20010.0	0306-0317-0314-000D					
1	31603170242 00 00	AA1041801297	AA10401	436.0	4020.0X130.0	1	2	474.0	0.0	948.0
2(2)	HORIZONTAL FLANGE STRIP			Y	PL 110					
MF DR M13					0072-0301-0306					KG
2	31601870386 00 00	AA1011819295	AA10119	623.0	5640.0X130.0	1	2	665.38	0.0	1330.76
2(2)	VERTICAL FLANGE STRIP		BORROWED	Y	PL 110					
MF DR L12					0072-0301-0306					KG
3	21603170142 00 00	AA1011819198	AA10119	2805.0	6183.0X1680.0	1	1	3428.0	0.0	3428.0
1(1)	MIDDLE PLATE			Y	PL 40					
MF DR K12					0072-0301-0306					KG
4	21603170143 00 00	AA1011819198	AA10119	1165.0	2500.0X3750.0	1	1	1546.88	0.0	1546.88
1(1)	SIDE CURVE PLATE			Y	PL 40				it includes blank for item 5	
MF DR L12					0072-0301-0306					KG
5	21603170144 00 00	AA1011819198	AA10119	1165.0	2500.0X3750.0	1	1	1546.88	0.0	1546.88
1(1)	SIDE CURVE PLATE			Y	PL 40				blank included in item 4	
MF DR L16					0072-0301-0306					KG
6	21603170145 00 00	AA1011819198	AA10119	800.0	3720.0X2500.0	1	1	1534.5	0.0	1534.5
1(1)	SIDE CURVE PLATE			Y	PL 40				it included blank,21603170146	
MF DR J16					0072-0301-0306					KG
7	21603170146 00 00	AA1011819198	AA10119	800.0	3720.0X2500.0	1	1	1534.5	0.0	1534.5
1(1)	SIDE CURVE PLATE			Y	PL 40				Blank included in,21603170145	
MF DR J12					0072-0301-0306					KG
8	21603170147 00 00	AA1011819198	AA10119	1075.0	2500.0X3480.0	1	1	1435.5	0.0	1435.5
1(1)	END CURVE PLATE			Y	PL 40				it includes blank for item 9	
MF DR M14					0072-0301-0306					KG
9	21603170148 00 00	AA1011819198	AA10119	1075.0	2500.0X3480.0	1	1	1435.5	0.0	1435.5
1(1)	END CURVE PLATE			Y	PL 40				blank included in item 8	
MF DR M15					0072-0301-0306					KG

ENGG

WTX

	Initial	Date	Initial	Date
Worked By	hxbsn	17.08.2011	wtxjk	11.10.2011
Checked By	hxeddt	11.10.2011	wtxhpr	11.10.2011
Approved By	hxemkl	12.10.2011	wtxhpr	11.10.2011



COMBINED BILL OF MATERIAL

Printed On: 12.09.2023

Printed By:

CBOM No: 01603170062 **CBOM Var:** 00
Description: FRONT WATER BOX (TUR.SIDE)

Revno: 49

Rev Date: 24.07.2019

Total weight: 18465.0

Item No	Drawingno Var Mvar	Mat Code	Mat Spec	Weight	Blank Sizes	Nos	Qty	Norm/pc	Extra Norm	Total Norm
Qty(Total)	Description		Assy. Remarks	Inclusion?	Mat Shape		Remarks			
Typ Cat Zone	Var/Matl. Description		ENGG SIZE/GRP	Fab Wt	Route				Spare Code	Unit
10	21603170151 00 00	AA1011819198	AA10119	420.0	2500.0X3460.0	1	1	1427.25	0.0	1427.25
1(1)	END CURVE PLATE			Y	PL 40		It included blank,21603170152			
MF DR G14					0072-0301-0306					KG
11	21603170152 00 00	AA1011819198	AA10119	420.0	2500.0X3460.0	1	1	1427.25	0.0	1427.25
1(1)	END CURVE PLATE			Y	PL 40		Blank included in 21603170151			
MF DR G14					0072-0301-0306					KG
12	31603170244 00 00	AA1011819155	AA10119	117.0	1678.0X528.0	1	2	182.7	0.0	365.4
2(2)	PROFILING PLATE			Y	PL 25					
MF DR L12					0072-0301-0306					KG
13	31603170245 00 00	AA1011819155	AA10119	57.0	1320.0X326.0	1	2	88.75	0.0	177.5
2(2)	PROFILING PLATE			Y	PL 25					
MF DR H12					0072-0301-0306					KG
14	31603170246 00 00	AA1011819198	AA10119	184.0	1214.0X485.0	1	0	0.0	0.0	0.0
2(2)	PAD			Y	PL 40		use offcut from item 10 & 11			
MF DR K16					0072-0301-0306					KG
15	21603170149 00 00			6490.0						
1(1)	BRANCH PIPE ASSLY.			Y						
MF DR J10			N	6490.0	0390					
15-1	31603170243 00 00	AA1041801335	AA10401	3850.0	2500.0X2250.0	1	1	6182.0	0.0	6182.0
1(1)	FLANGE			Y	PL 140		cut in 4 segments			
MF DR					0072-0301-0306-0301-0306					KG
15-2	21603170150 00 00	AA1011819198	AA10119	2140.0	8908.0X1020.0	1	1	2998.0	0.0	2998.0
1(1)	PIPE			Y	PL 40					
MF DR					0072-0301-0306					KG
15-3		AA1011819139	AA10119	31.6	2682.0X75.0	1	2	33.2	0.0	66.4
2(2)	PLATE 20X75X2682			Y	PL 20					
RM DR	ST-FE410 WB-PLATE				0072-0301-0306					KG
15-4		AA1011819139	AA10119	29.8	75.0X2535.0	1	2	31.3	0.0	62.6
2(2)	PLATE 20X75X2535			Y	PL 20					
RM DR	ST-FE410 WB-PLATE				0072-0301-0306					KG

	ENGG		WTX
	Initial	Date	Initial
Worked By	hxebsn	17.08.2011	wtxjk
Checked By	hxeddt	11.10.2011	wtxhpr
Approved By	hxemkl	12.10.2011	wtxhpr



COMBINED BILL OF MATERIAL

Printed On: 12.09.2023

Printed By:

CBOM No: 01603170062 **CBOM Var:** 00
Description: FRONT WATER BOX (TUR.SIDE)

Revno: 49

Rev Date: 24.07.2019

Total weight: 18465.0

Item No	Drawingno Var Mvar	Mat Code	Mat Spec	Weight	Blank Sizes	Nos	Qty	Norm/pc	Extra Norm	Total Norm
Qty(Total)	Description		Assy. Remarks	Inclusion?	Mat Shape		Remarks			
Typ Cat Zone	Var/Matl. Description		ENGG SIZE/GRP	Fab Wt	Route				Spare Code	Unit
15-5		AA1011819139	AA10119	26.0	75.0X2210.0	1	2	28.0	0.0	56.0
2(2)	PLATE 20X75X2210			Y	PL 20					
RM DR	ST-FE410 WB-PLATE				0072-0301-0306					KG
15-6		AA1011819139	AA10119	18.9	75.0X1606.0	1	2	19.9	0.0	39.8
2(2)	PLATE 20X75X1606			Y	PL 20					
RM DR	ST-FE410 WB-PLATE				0072-0301-0306					KG
15-7		AA1011819139	AA10119	3.4	75.0X290.0	1	52	3.6	0.0	187.2
52(52)	PLATE 20X75X290			Y	PL 20					
RM DR	ST-FE410 WB-PLATE				0072-0301-0306					KG
15-8		AA1011819139	AA10119	2.0	75.0X172.0	1	4	2.2	0.0	8.8
4(4)	PLATE 20X75X172			Y	PL 20					
RM DR	ST-FE410 WB-PLATE				0072-0301-0306					KG
15-9		AA1011819139	AA10119	2.9	75.0X246.0	1	4	3.04	0.0	12.16
4(4)	PLATE 20X75X246			Y	PL 20					
RM DR	ST-FE410 WB-PLATE				0072-0301-0306					KG
16	41603170009 00 00	AA1041801246	AA10401	17.5	190.0X240.0	1	6	27.5	0.0	165.0
6(6)	LIFTING LUG		BORROWED	Y	PL 70					
MF DR L10					0072-0301-0317-0306					KG
19	21603470040 00 00			201.0						
1(1)	Man Hole Assembly		BORROWED,SUB ASSLY.	Y						
MF DR K10			N		0306					
19-1	31603470091 00 00	AA1011819074	AA10119	45.0	300.0X1884.0	1	1	46.6	0.0	46.6
1(1)	Pipe			Y	PL 10					
MF DR					0072-0301-0306					KG
19-3	41601570007 00 00	AA1011819198	AA10119	40.9	765.0X765.0	1	1	59.5	0.0	59.5
1(1)	Plate Flange			Y	PL 40			OD/ID=765/600		
MF DR					0072-0301-0317-0306					KG
19-4	41601570008 00 00	AA1011819171	AA10119	108.0	765.0X765.0	1	1	154.5	0.0	154.5
1(1)	BLANK FLANGE			Y	PL 32					
MF DR					0072-0301-0317-0306					KG

ENGG

WTX

	Initial	Date	Initial	Date
Worked By	hxbsn	17.08.2011	wtxjk	11.10.2011
Checked By	hxeddt	11.10.2011	wtxhpr	11.10.2011
Approved By	hxemkl	12.10.2011	wtxhpr	11.10.2011



COMBINED BILL OF MATERIAL

Printed On: 12.09.2023

Printed By:

CBOM No: 01603170062 **CBOM Var:** 00
Description: FRONT WATER BOX (TUR.SIDE)

Revno: 49

Rev Date: 24.07.2019

Total weight: 18465.0

Item No	Drawingno Var Mvar	Mat Code	Mat Spec	Weight	Blank Sizes	Nos	Qty	Norm/pc	Extra Norm	Total Norm
Qty(Total)	Description		Assy. Remarks	Inclusion?	Mat Shape			Remarks		
Typ Cat Zone	Var/Matl. Description		ENGG SIZE/GRP	Fab Wt	Route				Spare Code	Unit
19-5 1(1) MF DR	41604570004 00 00 HANDLE	AA1010209086	AA10109	0.44 Y	325.0 RND 16 0072-0315-0306	1	1	0.513 RND DIA 16,L=325	0.0	0.513 KG
19-6 2(2) SI DR	SCRU HEX SET F.D.P A-14H M10X45	AA7121130076	AA7121130	0.029 Y	0.0 0075-0306	0	0	0.0	0.0	2.0 NO
19-7 1(1) SI DR	WASHER PNCHD A-ST 22	AA7161005078	AA7161005	0.017 Y	0.0 0075-0306	0	0	0.0	0.0	1.0 NO
19-8 2(2) MF DR	41601570001 00 00 LUG	AA1011819139	AA10119	0.38 Y	53.0X110.0 PL 20 0072-0301-0317-0306	1	2	1.3	0.0	2.6 KG
19-9 2(2) MF DR	41601570002 00 00 LUG	AA1011819139	AA10119	0.38 Y	53.0X110.0 PL 20 0072-0301-0317-0306	1	2	1.3	0.0	2.6 KG
19-10 1(1) RM DR	ROUND BAR DIA 20,L=310 ST-C20-HR-RND	AA1010209108	AA10109	0.75 Y	310.0 RND 20 0072-0315-0306	1	1	0.8 RND BAR DIA 20,L=310	0.0	0.8 KG
19-11 1(1) RM DR	NEOPREN GASKET DIA 670/576,S=4 RUBBER-HEAT-REST-TYP B SHEET	HW5981797061	0503.206	0.7 Y	670.0X670.0 4 0072-0306	1	1	2.7 DIA 670/576	0.0	2.7 KG
19-12 20(20) SI DR	BOLT HEX A-8.8 M24X110	AA7111124146	AA7111124	0.049 Y	0.0 0075-0306	0	0	0.0	0.0	20.0 NO
19-13 20(20) SI DR	NUT HEX. B-6 M24	AA7151112025	AA7151112	0.11 Y	0.0 0075-0306	0	0	0.0	0.0	20.0 NO
20 1(1) MF DR J2	31603470067 00 00 DRAIN PIPE		BORROWED , SUB.ASSLY. N	14.9 Y	0315-0306					

	ENGG	WTX		
	Initial	Date	Initial	Date
Worked By	hxebns	17.08.2011	wtxjk	11.10.2011
Checked By	hxeddt	11.10.2011	wtxhpr	11.10.2011
Approved By	hxemkl	12.10.2011	wtxhpr	11.10.2011



COMBINED BILL OF MATERIAL

Printed On: 12.09.2023

Printed By:

CBOM No: 01603170062 **CBOM Var:** 00
Description: FRONT WATER BOX (TUR.SIDE)

Revno: 49

Rev Date: 24.07.2019

Total weight: 18465.0

Item No	Drawingno Var Mvar	Mat Code	Mat Spec	Weight	Blank Sizes	Nos	Qty	Norm/pc	Extra Norm	Total Norm
Qty(Total)	Description		Assy. Remarks	Inclusion?	Mat Shape			Remarks		
Typ Cat Zone	Var/Matl. Description		ENGG SIZE/GRP	Fab Wt	Route				Spare Code	Unit
20-1		AA1011052628	AA10152	4.2	275.0	1	1	0.275	0.0	0.275
1(1)	PIPE DIA 115X5.4,L=275			Y	PI 115.0X5.40			PIPE DIA 115X5.4,L=275		
MF DR	ST-ERW-TUBE		275.0		0072-0315					MR
20-2	31650170182 10 00	AA1011819171	AA10119	3.62	230.0X230.0	1	1	14.0	0.0	14.0
1(1)	PLT FLANGE			Y	PL 32			DIA 230/105		
MF DR					0072-0301-0317-000D					KG
20-3	31650170181 10 00	AA1011819171	AA10119	5.65	230.0X230.0	1	1	13.97	0.0	13.97
1(1)	BLANK FLANGE			Y	PL 32			DIA 230		
MF DR					0072-0301-0317-0315					KG
20-4		HW5981797061	0503.206	0.02	158.0X158.0	1	1	0.05	0.0	0.05
1(1)	NEOPRENE GASKT DIA 158/116,S=4			Y	4			CAF SH S=1.6,DIA 158/116		
MF DR	RUBBER-HEAT-REST-TYP B SHEET				0072-0315					KG
20-5		AA7151115059	AA7151115	0.034	0.0	0	0	0.0	0.0	8.0
8(8)	NUT HEX. A-8			Y						
MF DR	M16				0075-0315					NO
20-6		AA7121123568	AA7121123	0.132	0.0	0	0	0.0	0.0	8.0
8(8)	SCRU HEX A- 8.8			Y						
SI DR	M16X65				0075-0315					NO
21		AA1010208012	AA10108	0.04	160.0	1	4	0.037	0.0	0.148
4(4)	ROD DIA 6,L=160			Y	RND 6					
MF DR J2	ST-A(FE410 WA)				0072-0315-0306					KG
22	31603470108 00			24.2						
1(1)	PERFORATED PIPE ASSLY.		BORROWED,SUB-ASSLY.	Y						
MF DR			N		0315-0317-0306					
22-1	31603470109 00	HW1071055704	AA10755	6.06	320.0	1	1	0.32	0.0	0.32
1(1)	SS PERE.PIPE			Y	PI 168.3X5					
MF DR					0072-0315-0317-0306					MR
22-2		AA1071839012	AA10739	0.8	156.0X156.0	1	1	1.0	0.0	1.0
1(1)	PLATE DIA 156			Y	PL 5			Dia 156		
MF DR	ST STAINLESS STEEL				0072-0301-0306					KG

ENGG

WTX

	Initial	Date	Initial	Date
Worked By	hxbsn	17.08.2011	wtxjk	11.10.2011
Checked By	hxeddt	11.10.2011	wtxhpr	11.10.2011
Approved By	hxemkl	12.10.2011	wtxhpr	11.10.2011



COMBINED BILL OF MATERIAL

Printed On: 12.09.2023

Printed By:

CBOM No: 01603170062 **CBOM Var:** 00
Description: FRONT WATER BOX (TUR.SIDE)

Revno: 49

Rev Date: 24.07.2019

Total weight: 18465.0

Item No	Drawingno Var Mvar	Mat Code	Mat Spec	Weight	Blank Sizes	Nos	Qty	Norm/pc	Extra Norm	Total Norm
Qty(Total)	Description		Assy. Remarks	Inclusion?	Mat Shape		Remarks			
Typ Cat Zone	Var/Matl. Description		ENGG SIZE/GRP	Fab Wt	Route				Spare Code	Unit
22-3 1(1) MF DR	31650170182 12 PLT FLANGE	AA1011819171	AA10119	3.62 Y	295.0X295.0 PL 32	1	1	23.0	0.0	23.0
					0072-0301-0317-0314-000D					KG
22-4 1(1) MF DR	31650170181 12 BLANK FLANGE	AA1011819171	AA10119	10.4 Y	295.0X295.0 PL 32	1	1	23.0	0.0	23.0
					0072-0301-0317-0306					KG
22-5 1(1) MF DR	HW5981797061 0503.206 NEOPREN GASKET DIA 212/170,S=4 RUBBER-HEAT-REST-TYP B SHEET			0.04 Y	212.0X212.0 4	1	1	0.05	0.0	0.05
					0072-0306					KG
22-6 8(8) SI DR	AA7111124014 AA7111124 SCRU HEX A-8.8 BOLT HEX A-8.8			0.023 Y	0.0 M20X65	0	0	0.0	0.0	8.0
					0075-0306					NO
22-7 8(8) SI DR	AA7151112017 AA7151112 NUT HEX A-8 NUT HEX. B-6			0.064 Y	0.0 M20	0	0	0.0	0.0	8.0
					0075-0306					NO
23 27(27) MF DR B11	31603470027 00 00 LADDER ARM	AA1010209108	AA10109 BORROWED	1.65 Y	700.0 RND 20	1	27	2.0	0.0	54.0
					0072-0301-0306					KG
24 20(20) MF DR	41603470008 00 00 ANGLE	AA1011819074	AA10119 BORROWED	0.6 Y	50.0X155.0 PL 10	1	20	0.6	0.0	12.0
					0072-0301-0317-0306					KG
25 1(1) RM DR F7	AA1011052288 AA10152 PIPE DIA 21.8X2.65,L=100 ST-ERW-TUBE			0.15 Y	100.0 PI 21.8X2.65	1	1	0.1	0.0	0.1
					0072-0315-0306					MR
26 1(1) MF DR F5	AA1010112163 AA10112 ROD DIA 32,L=8 ST-CD-HEX			0.05 Y	8.0 HEX 32	1	1	0.05	0.0	0.05
					0072-0315-0306					KG
27 3(3) MF DR F4	31603170017 01 00 BOSS	AA1070225207	AA10725 BORROWED	0.9 Y	60.0 RND 63	1	3	1.5	0.0	4.5
					0072-0315-0317-0306					KG

ENGG

WTX

	Initial	Date	Initial	Date
Worked By	hxbsn	17.08.2011	wtxjk	11.10.2011
Checked By	hxeddt	11.10.2011	wtxhpr	11.10.2011
Approved By	hxemkl	12.10.2011	wtxhpr	11.10.2011



COMBINED BILL OF MATERIAL

Printed On:12.09.2023

Printed By:

CBOM No: 01603170062 CBOM Var: 00
Description: FRONT WATER BOX (TUR.SIDE)

Revno: 49

Rev Date: 24.07.2019

Total weight: 18465.0

Item No	Drawingno Var Mvar	Mat Code	Mat Spec	Weight	Blank Sizes	Nos	Qty	Norm/pc	Extra Norm	Total Norm
Qty(Total)	Description		Assy. Remarks	Inclusion?	Mat Shape		Remarks			
Typ Cat Zone	Var/Matl. Description		ENGG SIZE/GRP	Fab Wt	Route				Spare Code	Unit
28	17.8370.016 00 00	HW7240196038	18.8370	0.014	0.0	0	0	0.0	0.0	3.0
3(3)	SEALING RING D44/35			Y	35					
SI DR F4					0075-0306					NO
29	24.8322.033 00 00	AA1010112198	AA10112	0.424	52.0	1	3	0.5	0.0	1.5
3(3)	PLUG M33X2			Y	HEX 46					
MF DR F4					0072-0315-0317-0306					KG
30	31603170202 00 00	W90716031019	AA0401201	0.8	0.0	1	1	1.0	0.0	1.0
1(1)	IDENTIFICATION PLATE		BORROWED	Y						
BO DR H10					0074-0306					NO
31		AA1011819155	AA10119	15.3	175.0X450.0	1	4	16.2	0.0	64.8
4(4)	PLATE 25X175X450			Y	PL 25					
RM DR E15	ST-FE410 WB-PLATE				0072-0301-0306					KG
32		AA1012708063	AA10108	16.6	1025.0	0	0	17.65	0.0	70.6
4(4)	CH ISMC 150X75X1025			Y	CH ISMC 150X75					
RM DR E15	ST-A(FE410 WA)CHANEL				0072-0301-0306					KG
33		AA1012708063	AA10108	17.3	1100.0	0	0	19.0	0.0	76.0
4(4)	CH ISMC 150X75X1100			Y	CH ISMC 150X75					
RM DR E15	ST-A(FE410 WA)CHANEL				0072-0301-0306					KG

CBOM

	ENGG		WTX	
	Initial	Date	Initial	Date
Worked By	hxebns	17.08.2011	wtxjk	11.10.2011
Checked By	hxeddt	11.10.2011	wtxhpr	11.10.2011
Approved By	hxemkl	12.10.2011	wtxhpr	11.10.2011

COPYRIGHT AND CONFIDENTIAL
 THE INFORMATION ON THIS DOCUMENT IS THE PROPERTY OF BHARAT HEAVY ELECTRICALS LIMITED. IT MUST NOT BE USED DIRECTLY OR INDIRECTLY IN ANY WAY DETRIMENTAL TO THE INTEREST OF THE COMPANY.
 21603170142

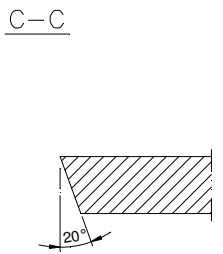
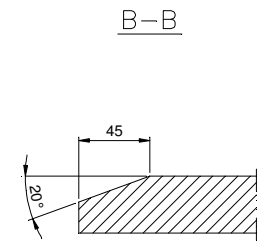
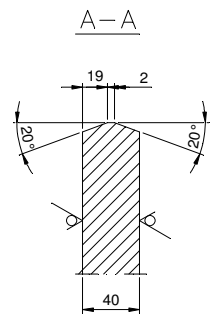
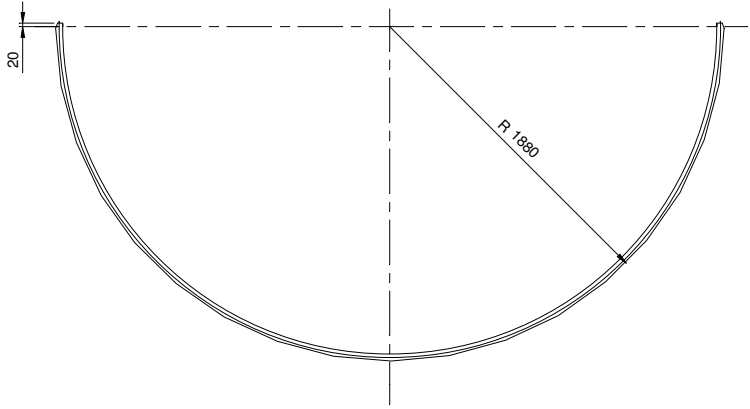
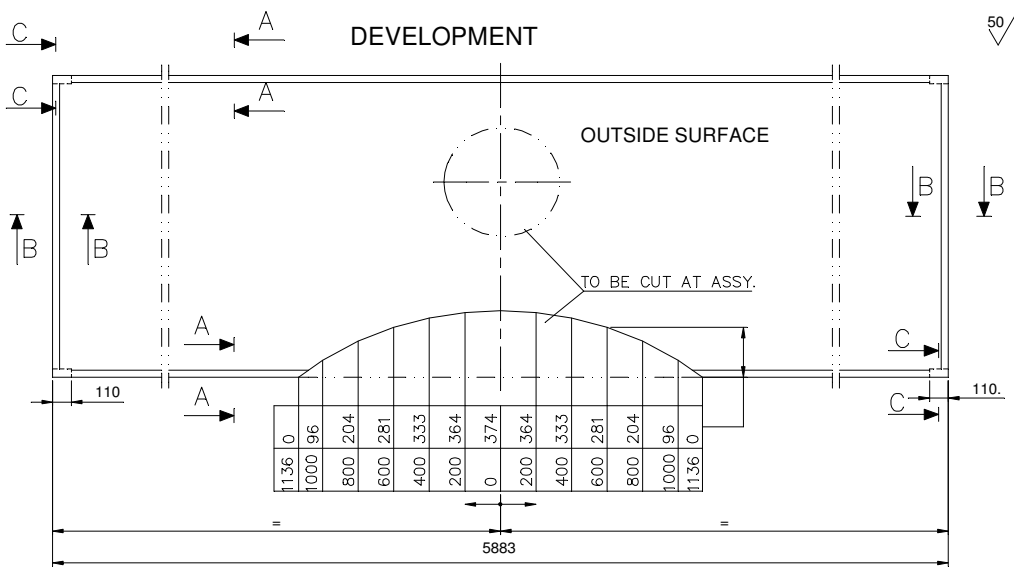
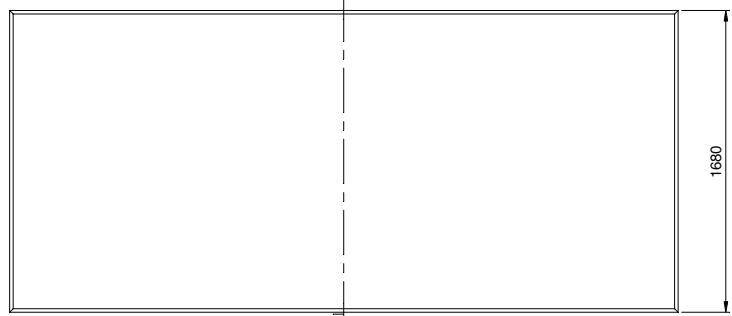

Asa*ya ivamaaeM ka vaga - GRADE OF UNTOLERANCED DIMENSION maSalinaMga ? ee0230208 ema MACHINING - AA0230208 m		sal*bal*Aao*ema*/C.B.O.M. 01603170062		Asa*ya ivamaaeM ka vaga - STATUS OF PRG. U		Paad ka p'kar yaa ga'ahkApiryaaajanaa ka naama TYPE OF PRODUCT OR NAME OF	
vaailDMMga ? ee0621104 ki EaoNal ba WELDING-CLASS 'B' OF AA0621104		WT JK sd/- 10.10.11		Bharat Heavy Electricals Limited RANIPUR, HARDWAR		naama/NAME hataxar/SIGN idnaMk/DATE S.N. NEGI sd/- 18.08.11	
gaUsa kiTMga ? ee0621101 ki saaNal		REV. DATE		REV. DATE		Asaombalal iBaklp ka saMBa- 2805	
REV. DATE		REV. DATE		REV. DATE		naga EmoaMk No. 23	
REV. DATE		REV. DATE		REV. DATE		naga EmoaMk No. 24	
REV. DATE		REV. DATE		REV. DATE		naga EmoaMk No. 25	
REV. DATE		REV. DATE		REV. DATE		naga EmoaMk No. 26	
REV. DATE		REV. DATE		REV. DATE		naga EmoaMk No. 27	
REV. DATE		REV. DATE		REV. DATE		naga EmoaMk No. 28	
REV. DATE		REV. DATE		REV. DATE		naga EmoaMk No. 29	
REV. DATE		REV. DATE		REV. DATE		naga EmoaMk No. 30	

MIDDLE PLATE

kaD-AiBaklp saM#yaa/DRAWING NO.
 21603170142
 kaad\ CARD CODE
 22 23 24
 A2 saqja/A2 SIZE

COPYRIGHT AND CONFIDENTIAL THE INFORMATION ON THIS DOCUMENT IS THE PROPERTY OF BHARAT HEAVY ELECTRICALS LIMITED. IT MUST NOT BE USED DIRECTLY OR INDIRECTLY IN ANY WAY DETERMINAL TO THE INTEREST OF THE COMPANY.

21603170143

2942	100
2779	260
2617	420
2455	576
2292	729
2130	878
1968	1020
1805	1155
1643	1283
1481	1403
1319	1513
1156	1613
994	1701
832	1776
669	1840
507	1890
345	1926
182	1949
110	1958
00	1940

DEVELOPMENT
SCALE 1: 10

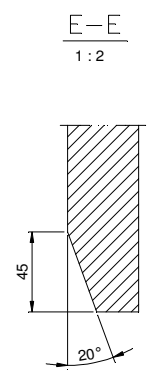
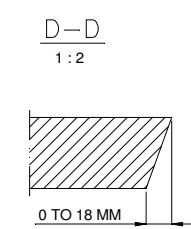
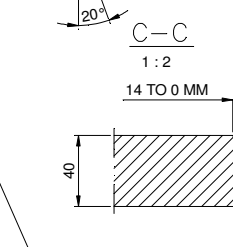
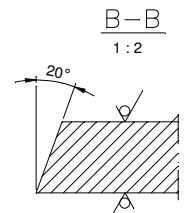
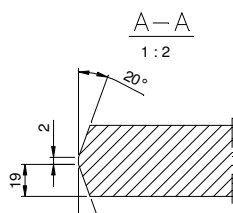
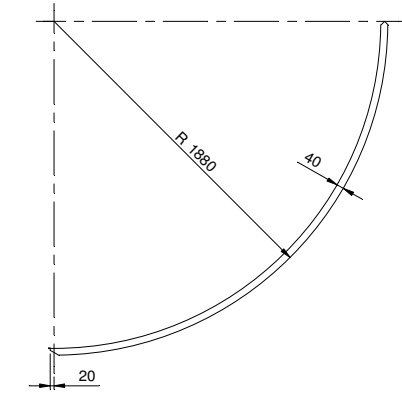
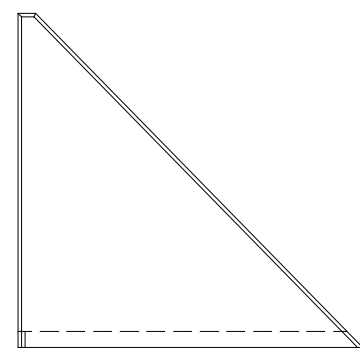
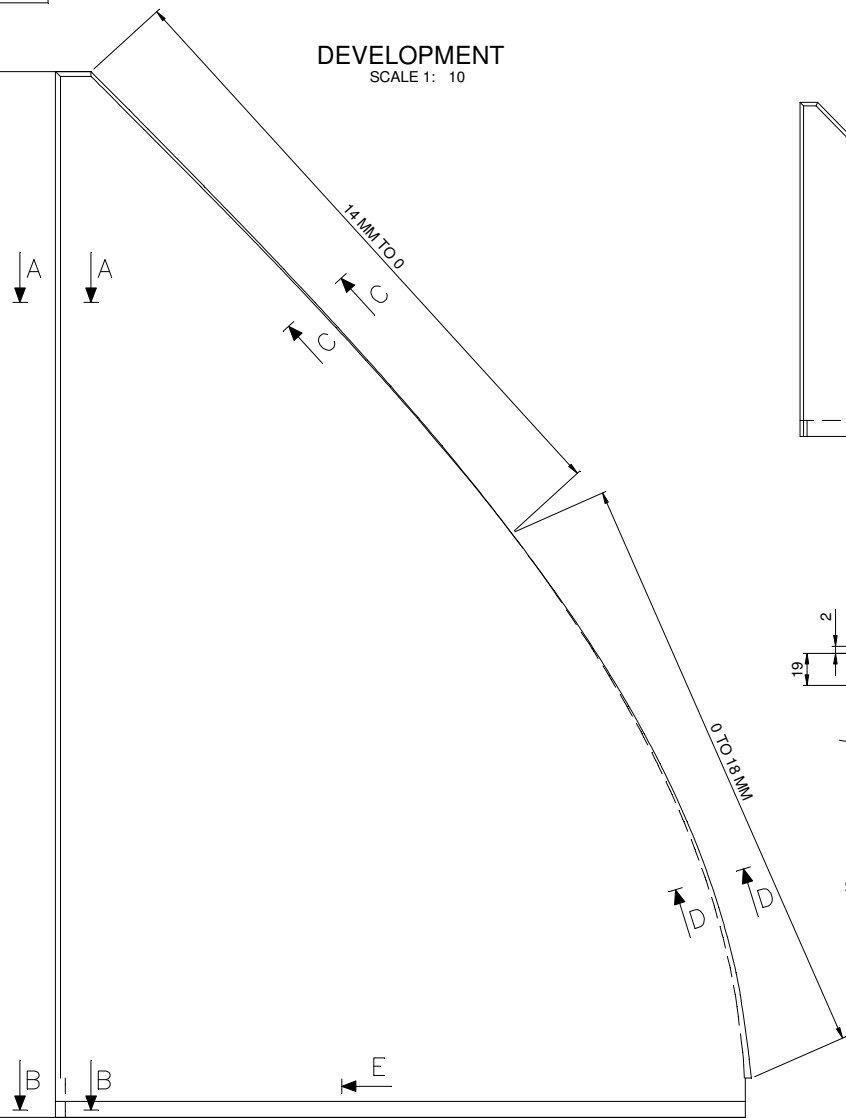

50 THE REST

Asa*ya ivamaaAaom ka vaga - GRADE OF UNTOLERANCED DIMENSION		sal*bal*Aao*emta*/C.B.O.M. 01603170062		AsaBa*ka de STATUS OF PRS.	
maSalinaMga ? ee0230208 ema MACHINING - AA0230208 m		saMala*vaMaga AGREED DEPT.		naama/NAME hastaxar/SIGN	
vaailMMga ? ee0621104 kl EaoNal ba WELDING-CLASS 'B' OF AA0621104		WT JK		sd/- 10.10.11	
gaUsa kiTMga ? ee0621101 kl saarNal					

SaYa-k/TITLE SIDE CURVE PLATE		Baar ik'ga'a WEIGHT (kg) 1165		Asaombalal iBaklp ka saMba- REPH 03170062DRG.		naga EmoaMk ITD 40.		naama/NAME hastaxar/SIGN EdnaMk/DATE		vaalMk/DATE No. of Vr.	
		1165		REPH 03170062DRG.		ITD 40.		D.D.T. sd/- 18.08.11		18.08.11	
				M.K.L. sd/- 10.10.11				sd/- 18.08.11		18.08.11	

REV. DATE		REV. DATE		REV. DATE		REV. DATE	

REV. DATE		REV. DATE		REV. DATE		REV. DATE	

COPYRIGHT AND CONFIDENTIAL
 THE INFORMATION ON THIS DOCUMENT IS THE PROPERTY OF BHARAT HEAVY ELECTRICALS LIMITED. IT MUST NOT BE USED DIRECTLY OR INDIRECTLY IN ANY WAY DETERMINAL TO THE INTEREST OF THE COMPANY.
 21603170144

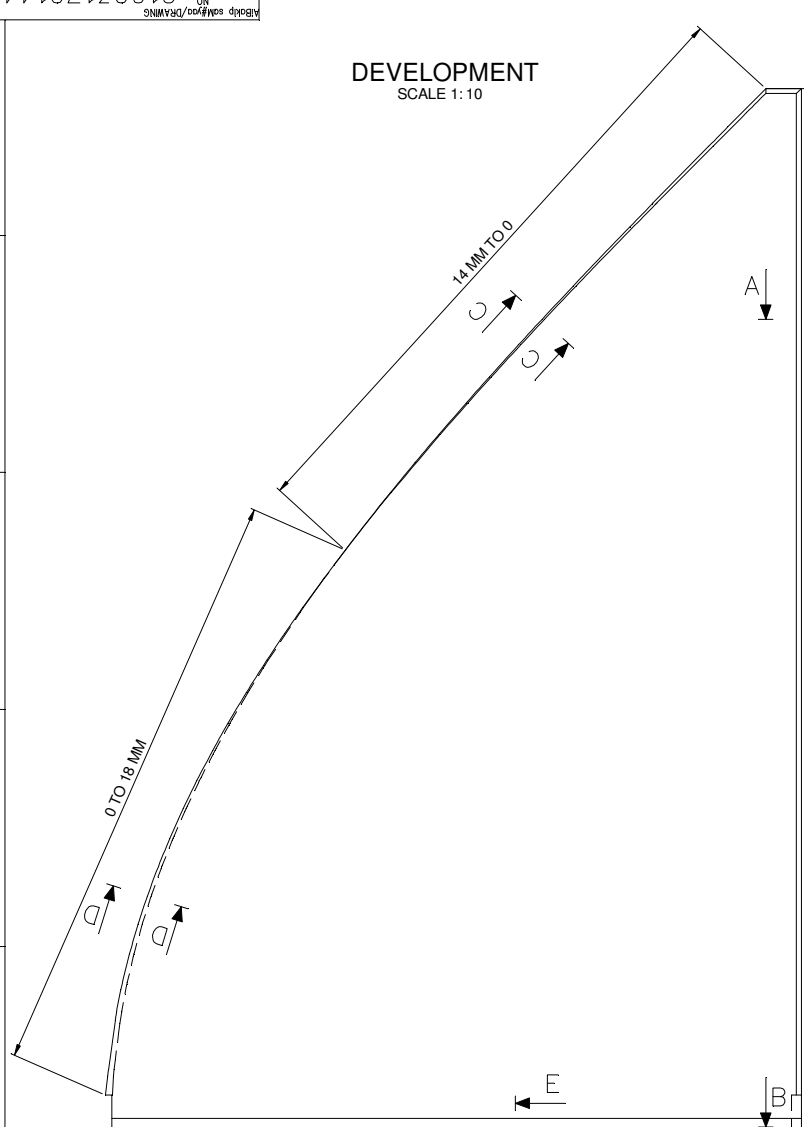

DEVELOPMENT
SCALE 1:10

100	2942
260	2779
420	2617
576	2455
729	2292
878	2130
1020	1968
1155	1805
1283	1643
1403	1481
1513	1319
1613	1156
1701	994
1776	832
1840	669
1890	507
1926	345
1949	182
1958	110
1940	00

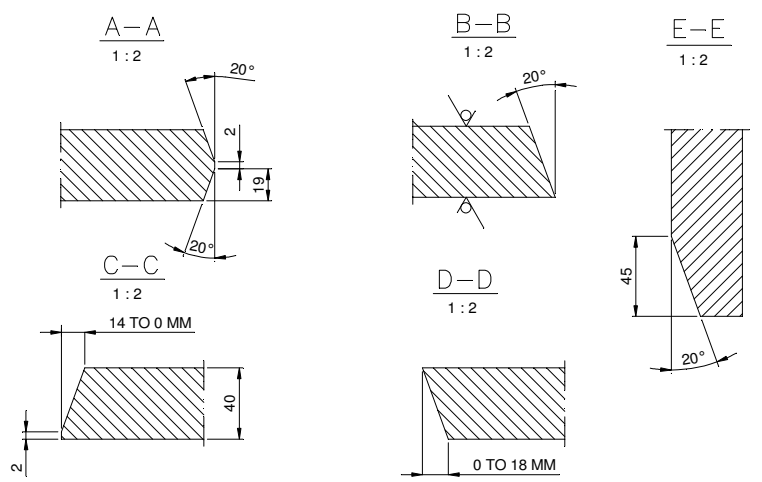
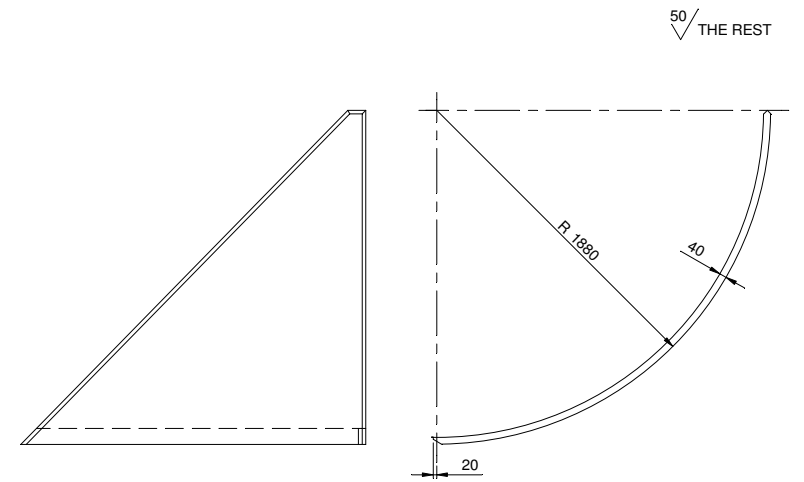

Asa*ya ivamaaAaom ka vaga - GRADE OF UNTOLERANCED DIMENSION		sal*bal*Aao*emta*/C.B.O.M. 01603170062		Asa*ya ivamaaAaom ka vaga - STATUS OF PRS.	
maSalinaMga ? ee0230208 ema		noama/NAME		iMmailamaTr maom hom.	
MACHINING - AA0230208 m		DATE		DATE	
vaolIMMga ? ee0621104 ki EaoNal ba		WT		JK	
WELDING-CLASS 'B' OF AA0621104		sd/-		10.10.11	
gaUsa kiTMga ? ee0621101 ki saaNal		REV.		DATE	
3		REV.		DATE	

Paad ka p'kar yaa
ga'ahkApiryaaajanaa ka naama
TYPE OF PRODUCT OR NAME OF

CUSTOMER/PROJECT
Bharat Heavy Electricals Limited
ranalpur? hirWar
Bharat Heavy Electricals Limited
RANIPUR, HARDWAR
Andapat/SCALE

noama/NAME
S. NEGI
D.D.T.
M.K.L.

hataxar/SIGN
sd/-
sd/-
sd/-

idnaMk/DATE
18.08.11
18.08.11
10.10.11

noagaMo ki saM#yaa No. of
1165

Asaombal iBaklp ka
saMba-
REPH 03170062 DRG.

kaod\ CARD CODE

saM#yaa/DRAWING NO.
21603170144

REV. 23 24

A2 saajya/A2 SIZE

SIDE CURVE PLATE

kaod\ CARD CODE
21603170144
REV. 23 24

COPYRIGHT AND CONFIDENTIAL THE INFORMATION ON THIS DOCUMENT IS THE PROPERTY OF BHARAT HEAVY ELECTRICALS LIMITED. IT MUST NOT BE USED DIRECTLY OR INDIRECTLY IN ANY WAY DETRIMENTAL TO THE INTEREST OF THE COMPANY.

121603170145

DEVELOPMENT
SCALE 1: 10

TO CUT AT ASSEMBLY

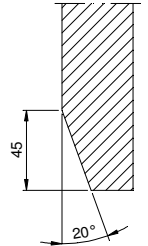
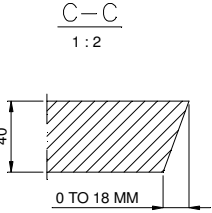
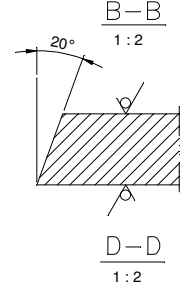
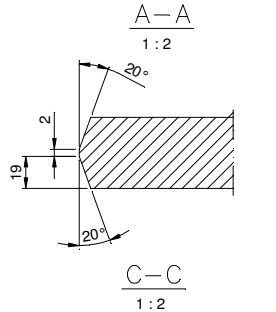
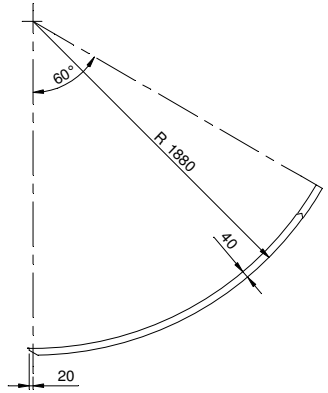
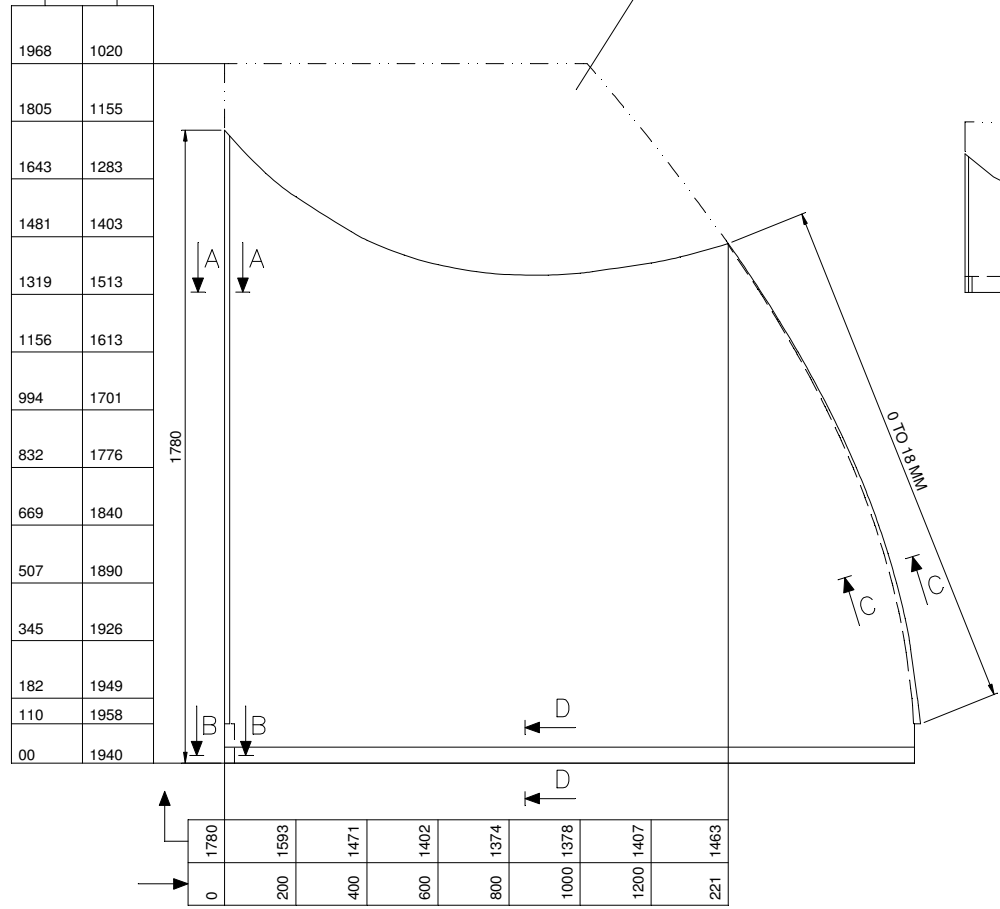

50 / THE REST

0	1780	1780	1593	1471	1402	1374	1378	1407	1463
110	1958	182	1949	345	1926	507	1890	669	1840
832	1776	994	1701	1156	1613	1319	1513	1481	1403
1643	1283	1805	1155	1968	1020				

Asa*ya ivamaaAaom ka vaga - GRADE OF UNTOLERANCED DIMENSION		saI*bal*Aao*enta*/C.B.O.M.		AsaBa ke de STATUS OF PRS.	
maSalinaMga ? ee0230208 ema		01603170062		U	
MACHINING - AA0230208 m		naama/NAME		ichaamk/DATE	
WT	JK	sd/-	10.10.11		
vaoliMMmga ? ee0621104 ki EaoNal ba		WELDING-CLASS 'B' OF AA0621104			
gaUsa kiTMga ? ee0621101 ki saarNal		3			

SaIYa-k/TITLE		SaBaM/PROJECT		naama/NAME		hataxar/SIGN		idnaMk/DATE		vaasht saM#yaa No. of Vrs.	
SIDE CURVE PLATE		BHARAT HEAVY ELECTRICALS LIMITED		D.D.T.		sd/-		18.08.11			
RANIPUR, HARDWAR		RANIPUR, HARDWAR		M.K.L.		sd/-		10.10.11			
CODE 4222		Baar ik'ga'a* WEIGHT (KG)		Asaombalal iBaBklp ka saMba- REPH 03170062 DRG.		naga EmaoMk (kg)		800		nagaMk ki saM#yaa No. OF VRS.	

REV.	DATE	ALTERED BY	REV.	DATE	ALTERED BY

C/S QUANTITY TABLE 3 OF AA0621101		REV.		DATE		ALTERED BY	

SaIYa-k/TITLE		SaBaM/PROJECT		naama/NAME		hataxar/SIGN		idnaMk/DATE		vaasht saM#yaa No. of Vrs.	
SIDE CURVE PLATE		BHARAT HEAVY ELECTRICALS LIMITED		D.D.T.		sd/-		18.08.11			
RANIPUR, HARDWAR		RANIPUR, HARDWAR		M.K.L.		sd/-		10.10.11			
CODE 4222		Baar ik'ga'a* WEIGHT (KG)		Asaombalal iBaBklp ka saMba- REPH 03170062 DRG.		naga EmaoMk (kg)		800		nagaMk ki saM#yaa No. OF VRS.	

kaod\ CARD CODE
saM#yaa/Sheets No. 21603170145
#Ryzaom ki saM#yaa/No. of Sheets 23 24
A2 saqja/A2 SIZE

COPYRIGHT AND CONFIDENTIAL THE INFORMATION ON THIS DOCUMENT IS THE PROPERTY OF BHARAT HEAVY ELECTRICALS LIMITED. IT MUST NOT BE USED DIRECTLY OR INDIRECTLY IN ANY WAY DETRIMENTAL TO THE INTEREST OF THE COMPANY.

121603170146

DEVELOPMENT
SCALE 1: 10

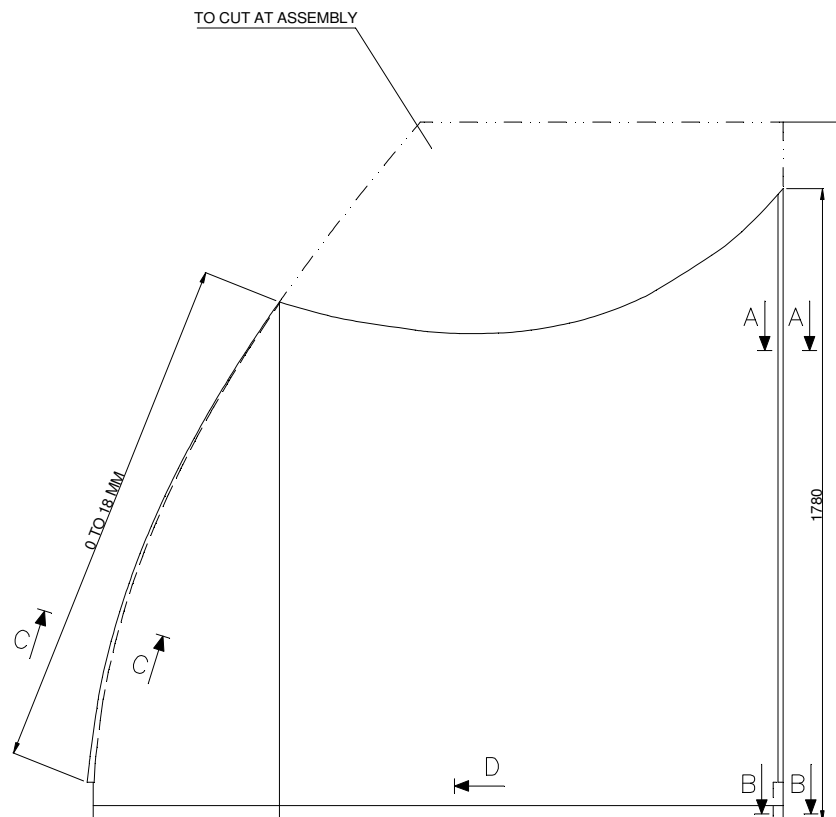

1020	1968
1155	1805
1283	1643
1403	1481
1513	1319
1613	1156
1701	994
1776	832
1840	669
1890	507
1926	345
1949	182
1958	110
1940	00

221	1463
1200	1407
1000	1378
800	1374
600	1402
400	1471
200	1583
0	1780

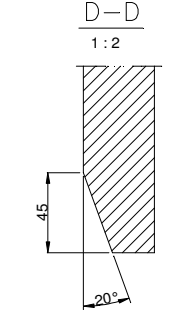
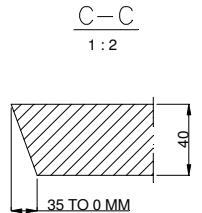
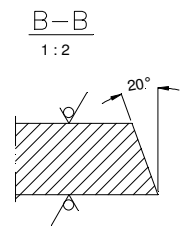
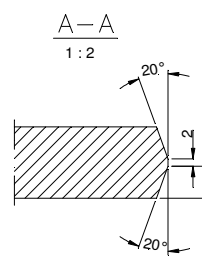
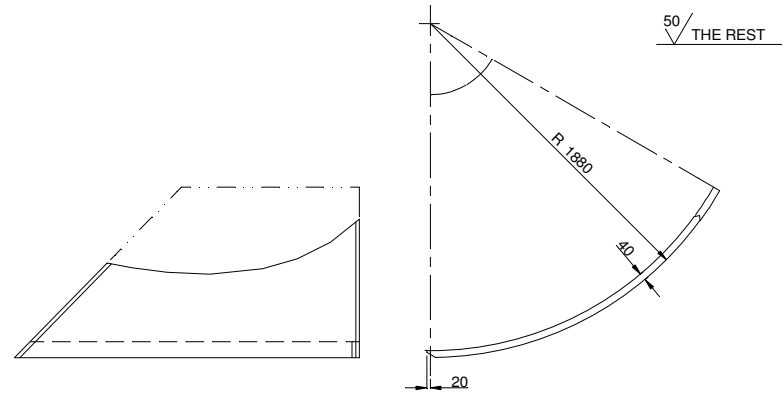

Asa'ya ivamaaAaom ka vaga - GRADE OF UNTOLERANCED DIMENSION	sal*bal*Aao*enta*/C.B.O.M.	Asa'ya ivamaaAaom ka vaga - STATUS OF PRG.
maSalinaMga ? ee0230208 ema MACHINING - AA0230208 m	01603170062	u
vaolIMMga ? ee0621104 kl EaoNal ba WELDING-CLASS 'B' OF AA0621104	WT JK sd/-	10.10.11
gaOsa kiTMga ? ee0621101 kl saaNal		

SaYa-k/TITLE		SaYa-k/TITLE		SaYa-k/TITLE	
SIDE CURVE PLATE		SIDE CURVE PLATE		SIDE CURVE PLATE	
REV.	DATE	REV.	DATE	REV.	DATE

Asaombal iBaklp ka DEPTT. IAS	Asaombal iBaklp ka DEPTT. IAS	Asaombal iBaklp ka DEPTT. IAS	Asaombal iBaklp ka DEPTT. IAS	Asaombal iBaklp ka DEPTT. IAS	Asaombal iBaklp ka DEPTT. IAS
REV. CODE 4222	REV. CODE 4222	REV. CODE 4222	REV. CODE 4222	REV. CODE 4222	REV. CODE 4222
1:20	1:20	1:20	1:20	1:20	1:20
800	800	800	800	800	800
21603170146	21603170146	21603170146	21603170146	21603170146	21603170146

Copyright and Confidential information on this document is the property of Bharat Heavy Electricals Limited. It must not be used directly or indirectly in any way detrimental to the interest of the company.

21603170148

2938	0
2775	160
2613	320
2451	476
2288	629
2126	778
1964	920
1801	1055
1639	1183
1477	1303
1315	1413
1152	1513
990	1601
828	1676
665	1740
503	1790
341	1826
178	1849
106	1880
00	1864

DEVELOPMENT
SCALE 1: 10

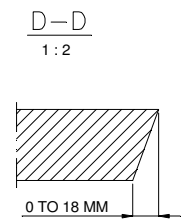
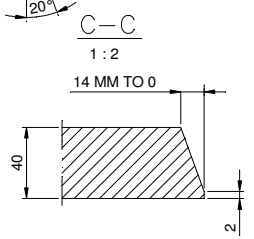
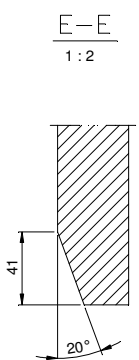
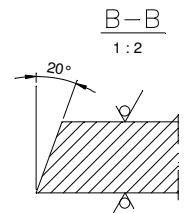
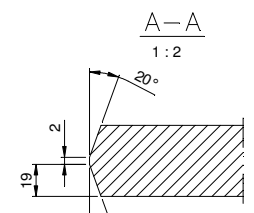
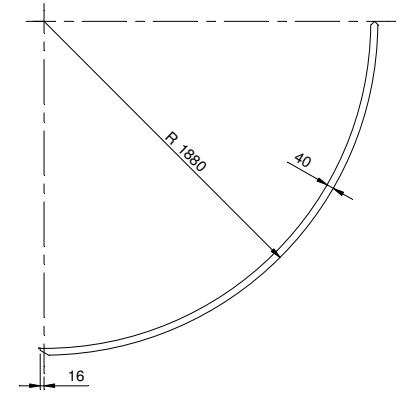
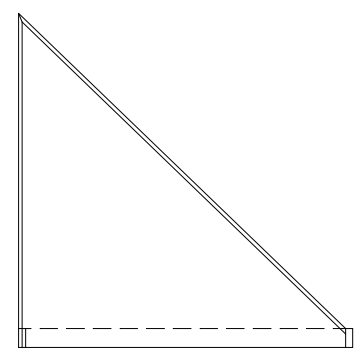
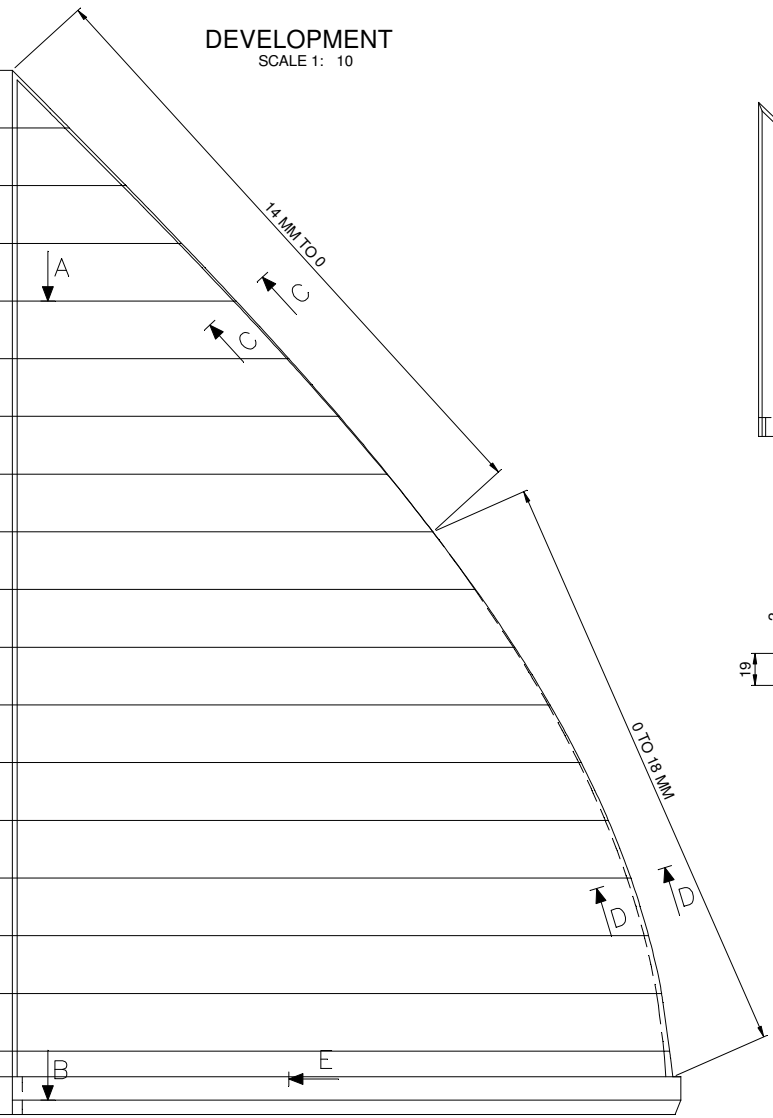

Asa*ya ivamaAaom ka vaga - GRADE OF UNTOLERANCED DIMENSION MACHINING - AA0230208 ma	sal*bal*Aao*emta*/C.B.O.M. 01603170062	Asa*ya ka de STATUS OF PRS. U
maSalinaMga ? ee0230208 ema	salma ivamaaeM AGREED DEPT.	noama/NAME hastaxar/SIGN
vaailMMmga ? ee0621104 kl EaoNal ba WELDING-CLASS 'B' OF AA0621104	WT	JK
gaUsa kitMga ? ee0621101 kl saarNal	sd/-	10.10.11
3		
REV.	DATE	ALTERED BY

Asa*ya ivamaAaom ka vaga - GRADE OF UNTOLERANCED DIMENSION MACHINING - AA0230208 ma		sal*bal*Aao*emta*/C.B.O.M. 01603170062		Asa*ya ka de STATUS OF PRS. U	
maSalinaMga ? ee0230208 ema		salma ivamaaeM AGREED DEPT.		noama/NAME hastaxar/SIGN	
vaailMMmga ? ee0621104 kl EaoNal ba WELDING-CLASS 'B' OF AA0621104		WT		JK	
gaUsa kitMga ? ee0621101 kl saarNal		sd/-		10.10.11	
3					
REV.		DATE		ALTERED BY	



BHARAT HEAVY ELECTRICALS LIMITED
RANIPUR, HARDWAR
Uttarakhand

SalYa-k/TITLE
END CURVE PLATE

noama/NAME PS. NEGI	hastaxar/SIGN sd/-	EdnaMk/DATE 18.08.11	vaolmT No. of Vr.
noama/NAME D.D.T.	hastaxar/SIGN sd/-	EdnaMk/DATE 18.08.11	vaolmT No. of Vr.
noama/NAME M.K.L.	hastaxar/SIGN sd/-	EdnaMk/DATE 10.10.11	vaolmT No. of Vr.

Asaombalal AiBaklp ka saMba- 1075	noaga EmoaMk 1075	noagaMo kl saMba No. of DRG.
21603170148	22	23
21603170148	23	24

DRAWING NO. 21603170149

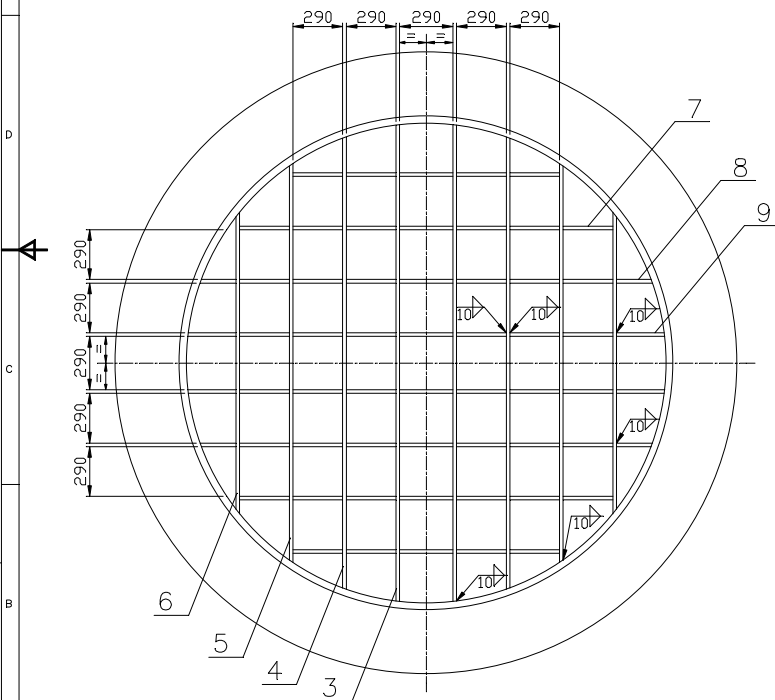
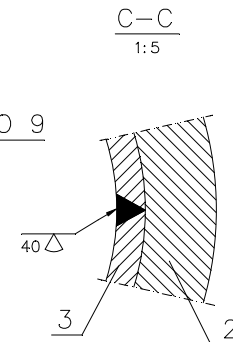
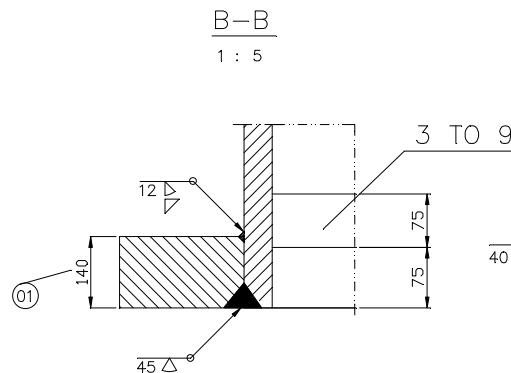
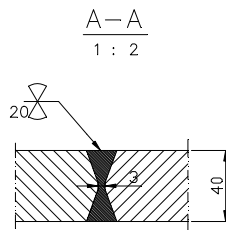
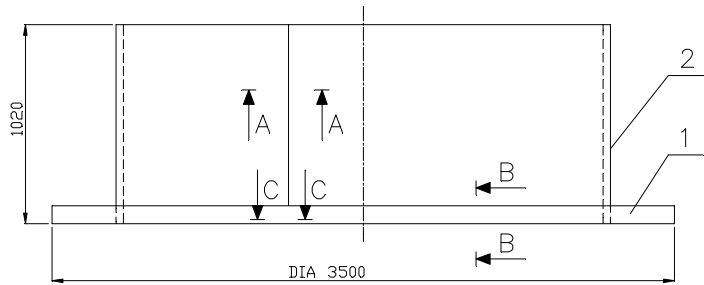

T.R. :-

1. VISUAL INSPECTION OF WELD SEAMS AS PER HW0620099.
CLASSIFICATION GROUPS :- CS/CK.
2. NON DESTRUCTIVE TESTING EXAMINATION OF WELD SEAMS AS PER HW0850199 PART 10.
3. THE GENERAL TOLERANCES OF STRAIGHTNESS, FLATNESS AND PARALLELISM SHALL BE MAINTAINED AS PER AA0621105 GRADE-F.

COPYRIGHT AND CONFIDENTIAL INFORMATION ON THIS DOCUMENT IS THE PROPERTY OF BHARAT HEAVY ELECTRICALS LIMITED. IT MUST NOT BE USED DIRECTLY OR INDIRECTLY IN ANY WAY DETRIMENTAL TO THE INTERESTS OF THE COMPANY.

INVENTORY NO. SIGN & DATE REF. DRG NO.

45Δ	40Δ	20Δ	12Δ	12P	10P	WELD SIZE & SYMBOL	GRADE OF UNTOL. DIM.:-
8.73	0.11	2.04	8.73	8.73	20.4	SEAM LENGTH IN M.	M/CS-V/C/M/F-AA-0230208
59.4	0.67	4.46	7.42	6.5	11.06	WT. OF DEPOSITED METAL	WELDING-K/B/K/β-AA621104
E-7018						TYPE OF ELECTRODE	GAS CUTTING-T3'AA0621101

CBOM NO. 01603170062		STATUS OF DRG.	
AGREED	NAME	SIGN	DATE
WT	J.K.	SD/-	10.10.11
REV. DATE	ALTERED	REV. DATE	ALTERED
	CHECKED	01	16.02.12
		CHECKED T.BANSAL SD/-	
HXE-12-F0045			
CHANGE MARK AS PER ⑪			

TYPE OF PRODUCT OR NAME OF CUSTOMER/ PROJECT		BHARAT HEAVY ELECTRICALS LTD. HARDWAR	
DRN	NAME	SIGN	DATE
CHD	BSN	SD/-	18.08.11
APD	DDT	SD/-	18.08.11
	MKL	SD/-	18.08.11
DEPT. HXE	SCALE	WEIGHT(Kg.)	REF. TO ASSY. DRG.
CODE 4222	1:20	6490	01603170062
TITLE		DRAWING NO.	ITEM NO.
BRANCH PIPE ASSLY.		21603170149	11
		SHEET NO. 01	NO.OF SHEETS 01

21603170150

DRAWING NO.

DEVELOPMENT

CUTTING LINE INCLUDES 50 mm FABRICATION MARGIN

TO CUT AT ASSEMBLY

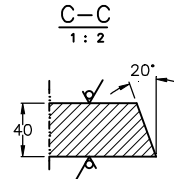
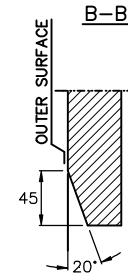
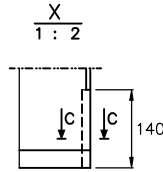
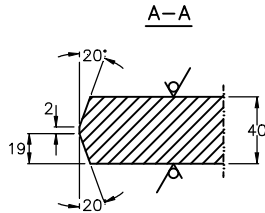
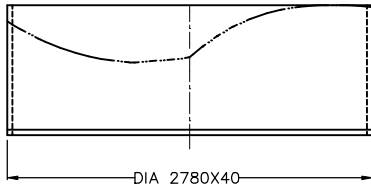
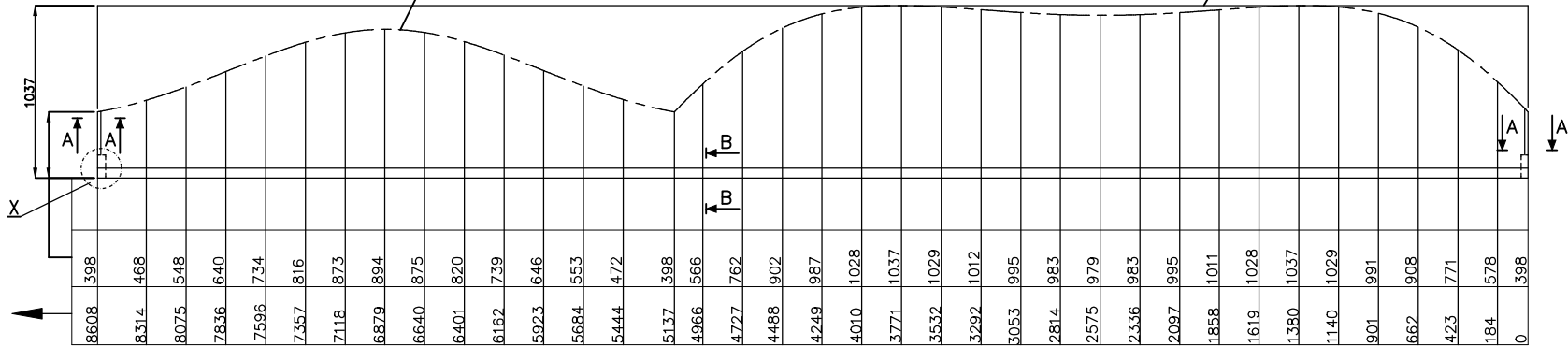

COPYRIGHT AND CONFIDENTIAL INFORMATION ON THIS DOCUMENT IS THE PROPERTY OF BHARAT HEAVY ELECTRICALS LIMITED. IT MUST NOT BE USED DIRECTLY OR INDIRECTLY IN ANY WAY DETRIMENTAL TO THE INTERESTS OF THE COMPANY.

INVENTORY NO. SIGN & DATE REF. DRG NO.

CBOM NO. 01603170062		STATUS OF DRG.		TYPE OF PRODUCT OR NAME OF CUSTOMER/ PROJECT				
AGREED	NAME	SIGN	DATE					
W.T.	BL MEENA	sd/-	4.05.15					
GRADE OF UNTOL. DIM.: -				BHARAT HEAVY ELECTRICALS LTD. HARDWAR				
M/CG- X/Y/M/Y AA 0230208								
WELDING- K/B/Y/Y-AA621104								
GAS CUTTING-T3'AA0621101				DRN	NAME	SIGN	DATE	NO. OF VAR.
REV. DATE ALTERED CHECKED				01	T.BANSAL	-Sd..	28.04.15	
REV. DATE ALTERED A.K. CHECKED T.BANSAL				CHD	R.BANSAL	-Sd..	28.04.15	
HXE-15-F0054				APD	S.KANT	-Sd..	29.04.15	13, 24
DRG SUPERSEDE UNDER THE SAME NO.				DEPT. HXE	SCALE	WEIGHT(Kg.)	REF. TO ASSY. DRG.	ITEM NO. NO. OF
				CODE 4222	1:20	2140	21603170149	02
				TITLE		DRAWING NO.		
				PIPE		21603170150		
						SHEET NO. 01		NO. OF SHEETS 01

Copyright and Confidential information notice on the left edge of the drawing.

21603170152

DEVELOPMENT SCALE 1: 10

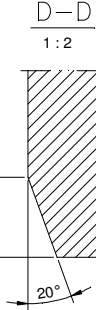
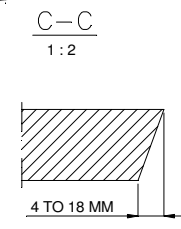
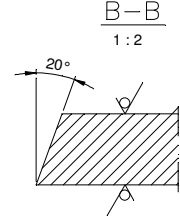
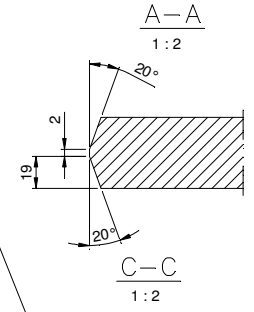
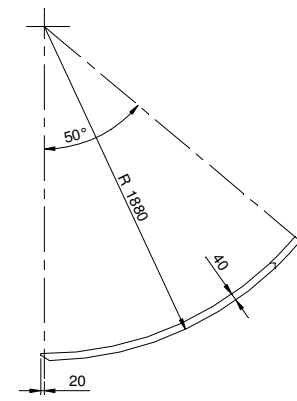
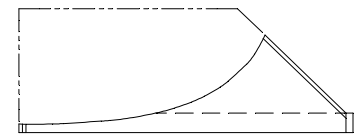
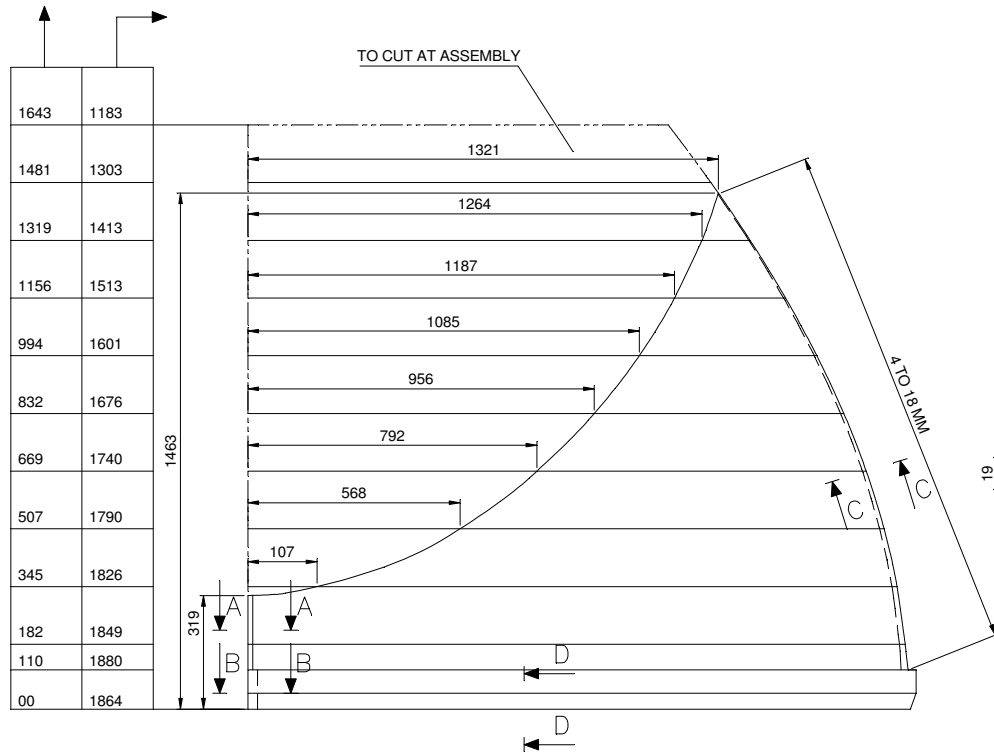

50 THE REST

Technical drawing header table containing project details, revision history, and drawing information.

END CURVE PLATE

Drawing number: 21603170152, Date: 22/03/2024, Sheet: 23 of 24.

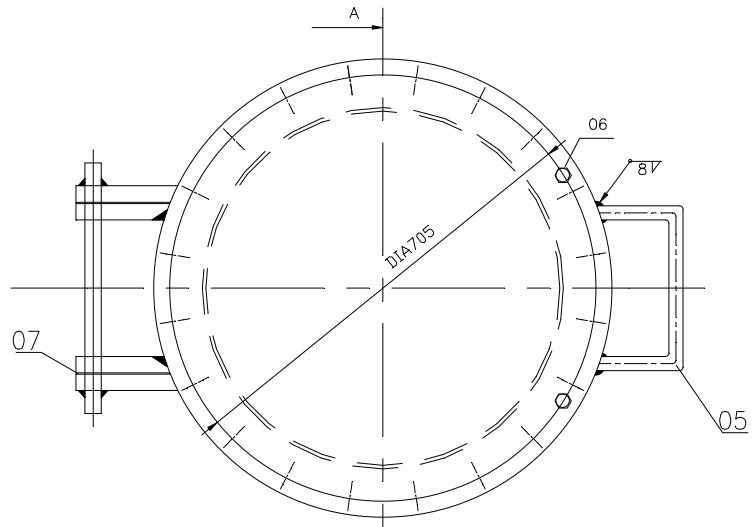

VIEW IN OPEN CONDITION

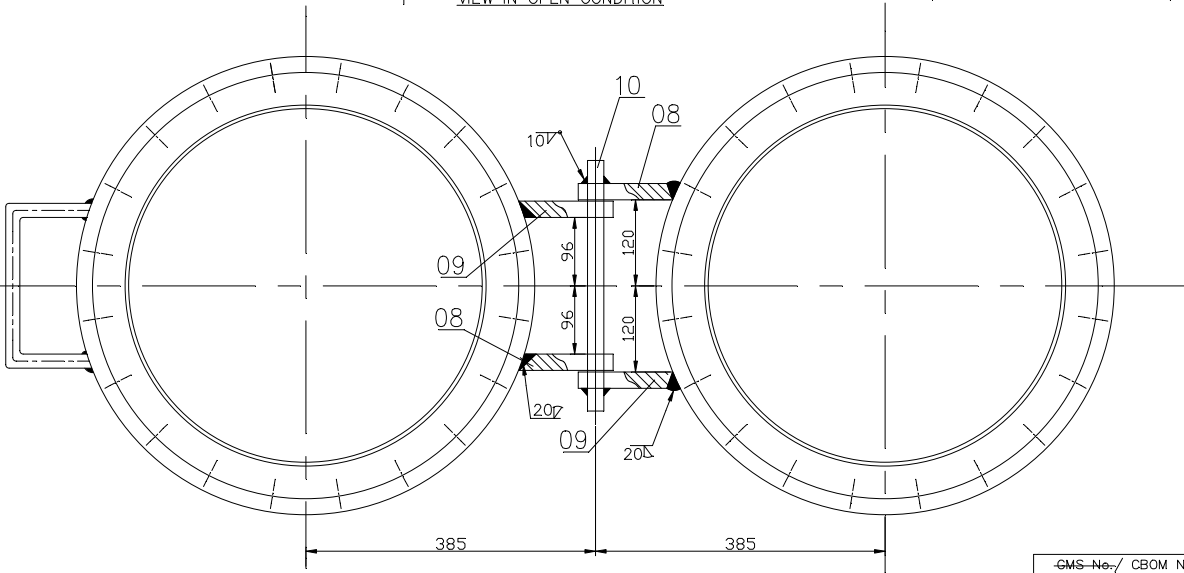
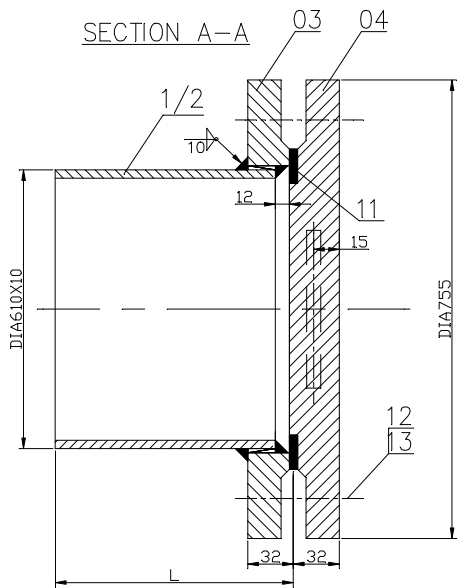

TABLE :-

VAR.	L	WT.(Kg)
00	312	174
01	712	233

T.R. -

WELDING QUALITY NOTE :-

WELDING CLASSIFICATION GROUP ACCORDING TO HW0620099 CS/BK, TEST SCOPE ACCORDING TO HW0850199 CATEGORY OF SERVICE REQUIREMENTS-3.

Sign & Date
Ref. Drawing No.

GRADE OF UNTOL.DIM
M/CG.-C/M/F AA0230208
WELDING-A/B/C/D AA0621104
GAS CUTTING-'T3'AA0621101

GMS No./ CBOM No.		STATUS OF DRG	
0-160-34-70036		U	
AGREED	NAME	SIGN	DATE
WT	I RAM	sd/-	23.09.06
REV	DATE	ALTERED	M.S.
01	03.10.12	CHECKED	A.K.
HXE-12-F0206			
VARIANT 01 ADDED.			

TYPE OF PRODUCT		2X250 MW NEYVELI	
OR		NAME OF CUSTOMER/PROJECT	
BHARAT HEAVY ELECTRICALS LTD.		RANIPUR, HARDWAR	
DRN	NAME	SIGN	DATE
RKK	NP	Sd/-	16/09/06
CHD	NP	Sd/-	21/09/06
APPD	NPM	Sd/-	25/09/06
DEPT	HXE	SCALE	WEIGHT (KG)
CODE	4222	1:1	149
TITLE :		REF. TO ASSY. DRG.	ITEM No.
MAN HOLE ASSEMBLY		01603470036	01
CARD CODE	DRAWING NO.	NO. OF SHEETS	
7	21603470040	22	23 24
SHEET No. 01		No. OF SHEETS 01	

REV	DATE	ALTERED CHECKED	REV	DATE	ALTERED CHECKED	REV	DATE	ALTERED CHECKED	REV	DATE	ALTERED CHECKED	REV	DATE	ALTERED CHECKED

DRAWING NO. 31601870386

COPYRIGHT AND CONFIDENTIAL
THE INFORMATION ON THIS DOCUMENT IS THE PROPERTY OF
BHARAT HEAVY ELECTRICALS LIMITED . IT MUST NOT BE USED DIRECTLY
OR INDIRECTLY IN ANY WAY DETRIMENTAL TO THE INTEREST OF THE COMPANY.

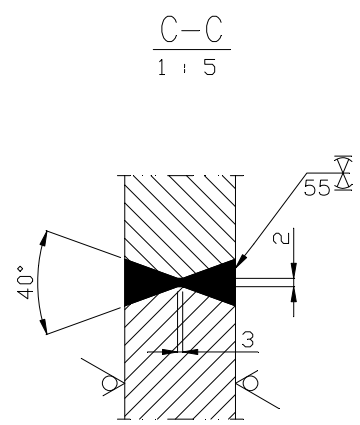
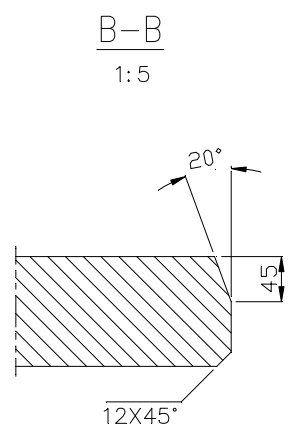
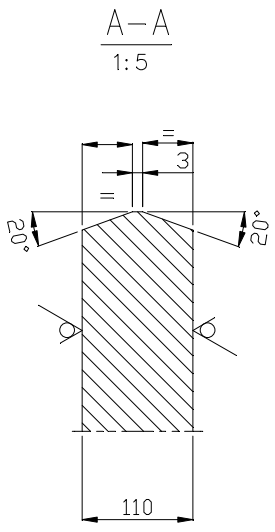
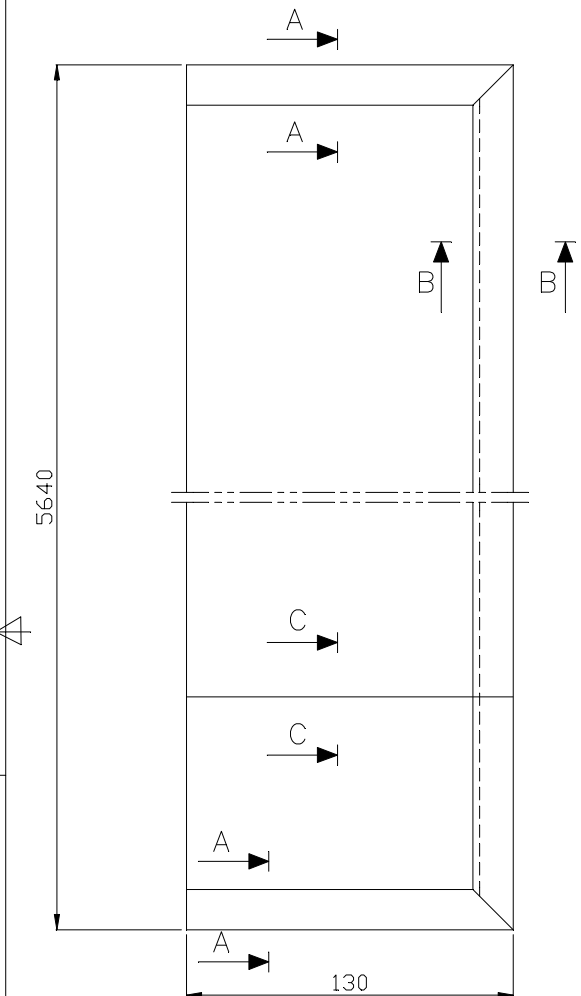

50/ THE REST

T.R.:-

1. VERTICAL FLANGE STRIP MAY BE MADE IN TWO PARTS AS PER DETAIL-I. THE WELD SEAM SHOULD NOT FALL ON FLANGE HOLES.
2. VISUAL INSPECTION OF WELD SEAM AS PER HW0620099 CLASSIFICATION GROUP : BS/BK.
3. NON DESTRUCTIVE EXAMINATION OF WELD SEAMS AS PER HW0850199, PART-10.

INVENTORY NO.	SIGN & DATE	REF. DRG NO.
---------------	-------------	--------------

GRADE OF UNTOL. DIM.: -		
M/CG-	AA	0230208
WELDING-	AA621104	
GAS CUTTING-	AA0621101	
REV.	DATE	ALTERED / CHECKED

CBOM NO. 116018700022		STATUS OF DRG.	
AGREED DEPT.	NAME	SIGN	DATE
WT.	J.K.	Sd.	06.09.2011

TYPE OF PRODUCT OR NAME OF CUSTOMER/ PROJECT	DRN	NAME	SIGN	DATE	NO.OF VAR.
BHARAT HEAVY ELECTRICALS LTD. HARDWAR	CHD	B.S.N.	Sd.	29.07.2011	
	APD	D.D.T.	Sd.	29.07.2011	
		M.K.L.	Sd.	08.09.2011	73, 74

DEPT. HXE	SCALE	WEIGHT(Kg.)	REF. TO ASSY. DRG.	ITEM NO.	NO.OF ITEMS
CODE 4222	1:2	623.0	11601870022	07	75, 77

TITLE	DRAWING NO.
VERTICAL FLANGE STRIP	31601870386
SHEET NO. 01 NO.OF SHEETS 01	

DRAWING NUMBER
3-160-31-70017

25 THE REST

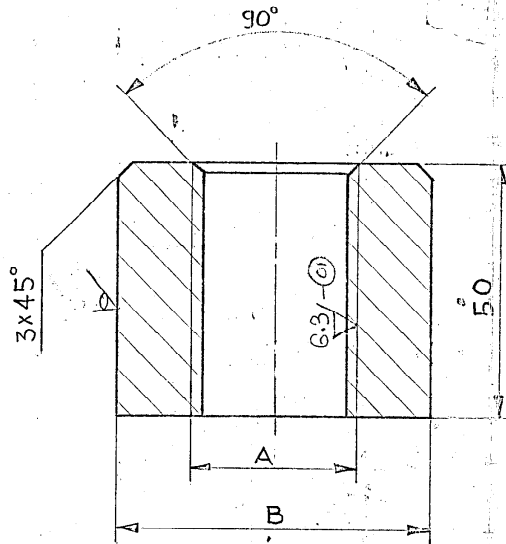

TABLE I

VARIANT	A	B
01	M33x2	φ63
02	M20x1.5	φ40
03	M56x4	φ100

TABLE II

REF. TO ASSEMBLY DRAWING	ITEM No.	VARIANT No.
0-160-31-70001	22	01
	24	02
	36	03
0-160-32-70001	22	01
	24	02
	36	03
0-160-34-70002	22	01
	24	02
	36	03
0-160-35-70001	22	01
	24	02
	36	03

VAR.00	REMARKS	KEY NO.	DESCRIPTION	DRAWING NO.	MATERIAL CODE	UNIT	UNIT WT. (Kg)
003			BOSS M56X4	3-160-31-70017	AA1070225266	kg	3.0
002			BOSS M20X1.5	3-160-31-70017	AA1070225169	kg	0.5
001			BOSS M33X2	3-160-31-70017	AA1070225207	kg	0.9

GMS/GR-SP. NO. 0-160-31-70001				STATUS OF DRG.				TYPE OF PRODUCT OR NAME OF CUSTOMER/PROJECT				
AGREED DEPT.	NAME	SIGN	DATE	BHARAT HEAVY ELECTRICALS LTD. RANIPUR - HARDWAR				DRN	NAME	SIGN	DATE	NO. OF VAR.
N.T.	GARG	SPG	14.6.84					CHD	P.S.		20/12	
								APPD	K.N.M.		20/12	73/74
REV	DATE	ALTERED	CHECKED	DEPT	GRADE OF	SCALE	WEIGHT (Kg)	REF. TO ASSY. DRG.		ITEM NO.	NO. OF ITEMS	
01	3.10.88			HXE	UNTOLDIM	1:1	SEE	SEE TABLE II				
HXE-88-162 Surface finish ✓ checked.				CODE	C/M/F		BOPT.					
				TITLE	BOSS		CARD CODE	DRAWING NO.		REV.		
							X52	3-160-31-70017		22 23 24		
								SHEET NO. 1		NO. OF SHEETS - 1		

The information on this document is the property of BHARAT HEAVY ELECTRICALS LIMITED. It must not be used directly or indirectly in anyway detrimental to the interest of the company.

Ref. Dwg. No.

Sign. & Date

Inventory No.

DRAWING NO. 31603170242

50° THE REST.

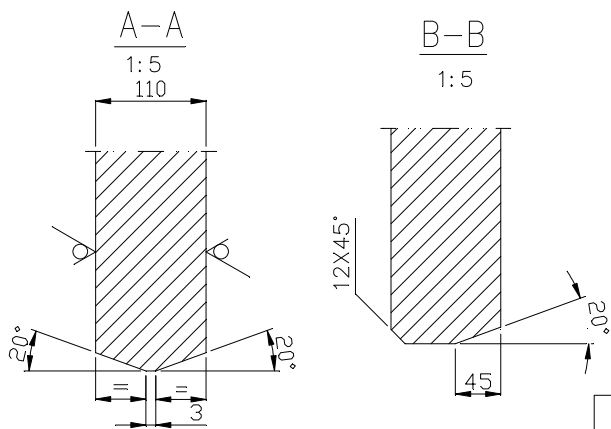
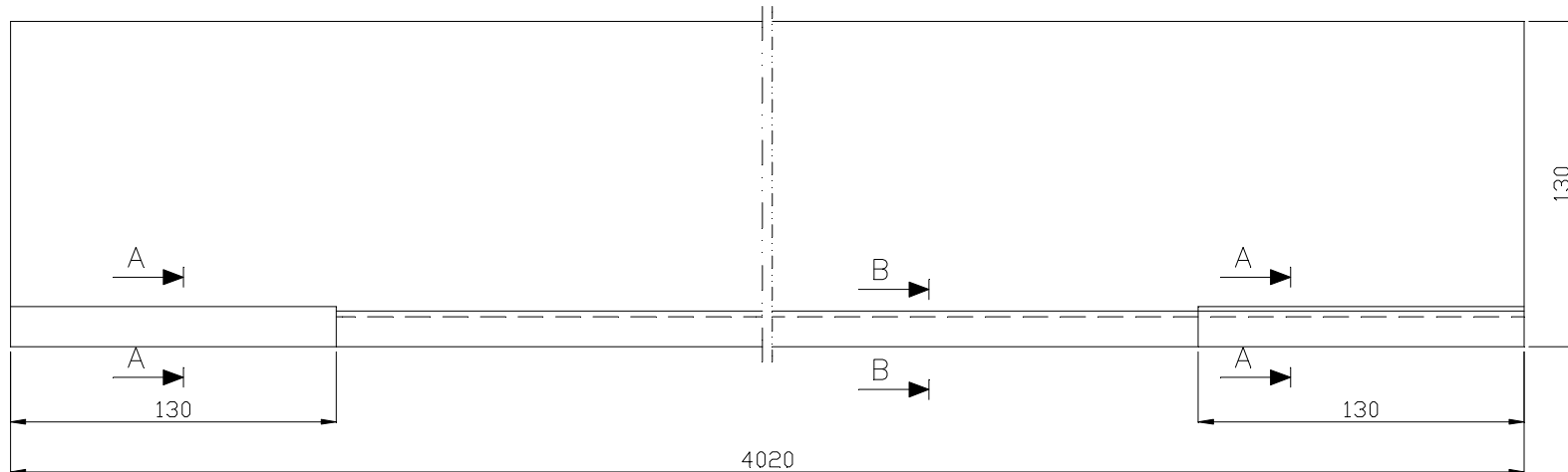

INVENTORY NO. SIGN & DATE REF. DRG NO.

GRADE OF UNTOL. DIM.: -		
M/CG-	$\chi/\phi/M/\text{F}$	AA 0230208
WELDING-	$\chi/B/\phi/\text{P}$	AA621104
GAS CUTTING-	'T3'	AA0621101
REV.	DATE	ALTERED CHECKED

CBOM NO. 01603170062		STATUS OF DRG.	
AGREED DEPT.	NAME	SIGN	DATE
WT.	J.K.	Sd.	10.10.2011

TYPE OF PRODUCT OR NAME OF CUSTOMER/ PROJECT			
--	--	--	--

	BHARAT HEAVY ELECTRICALS LTD. HARDWAR			DRN	NAME	SIGN	DATE	NO. OF VAR.
	CHD	D.D.T.	Sd.	18.08.2011				
	APD	M.K.L.	Sd.	10.10.2011				73, 74

DEPT. HXE	SCALE	WEIGHT(Kg.)	REF. TO ASSY. DRG.	ITEM NO.	NO. OF ITEMS
CODE 4222	1:20	436.0	01603170062	01	75, 77

TITLE	DRAWING NO.
HORIZONTAL FLANGE STRIP	31603170242
SHEET NO. 01	NO. OF SHEETS 01

COPYRIGHT AND CONFIDENTIAL THE INFORMATION ON THIS DOCUMENT IS THE PROPERTY OF BHARAT HEAVY ELECTRICALS LIMITED. IT MUST NOT BE USED DIRECTLY OR INDIRECTLY IN ANY WAY DETRIMENTAL TO THE INTEREST OF THE COMPANY.

DRAWING NO. 31603170243

50/ THE REST

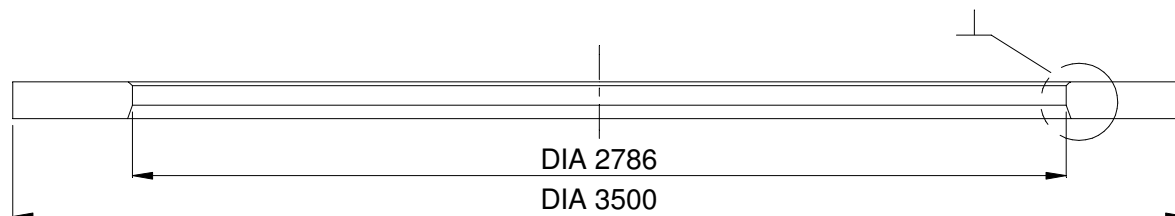
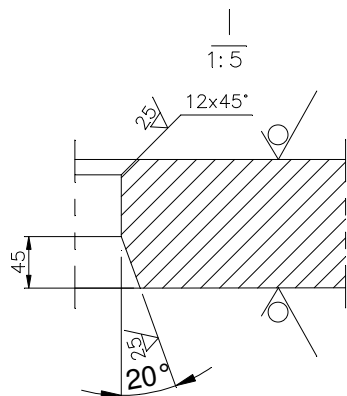

T.R: -

1. THE FLANGE MAY BE FABRICATED IN FOUR PARTS AS PER DETAIL-II.
2. VISUAL INSPECTION OF WELD SEAM AS PER HW0620099 CLASSIFICATION GROUP BS/BK.
3. NON DESTRUCTIVE EXAMINATION OF WELD SEAM AS PER-HW0850199, PART 10.

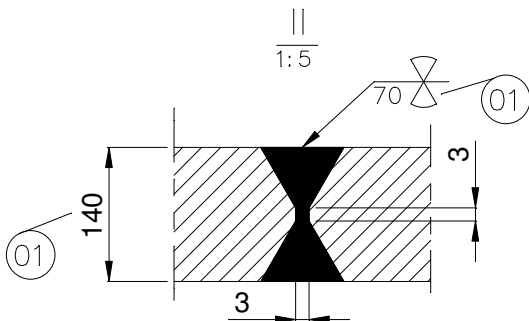

COPYRIGHT AND CONFIDENTIAL
THE INFORMATION ON THIS DOCUMENT IS THE PROPERTY OF
BHARAT HEAVY ELECTRICALS LIMITED . IT MUST NOT BE USED DIRECTLY
OR INDIRECTLY IN ANY WAY DETRIMENTAL TO THE INTEREST OF THE COMPANY.

INVENTORY NO.	SIGN & DATE	REF. DRG NO.	CBOM NO.		STATUS OF DRG.	
			01603170062			
GRADE OF UNTOL. DIM.: -			AGREED DEPT.	NAME	SIGN	DATE
M/CG- V/C/M/F AA-0230208			WT	JK	sd/	10.10.11
WELDING- X/B/P/D-AA621104						
GAS CUTTING-'T3'AA0621101						
REV.	DATE	ALTERED	REV.	DATE	ALTERED BSN	sd/-
		CHECKED	01	16.01.12	CHECKED T.BANSAL	sd/-
			HXE-12-F0045			
			CHANGE AS PER MARKED 01			

TYPE OF PRODUCT OR NAME OF CUSTOMER/ PROJECT		NAME		SIGN	DATE	NO.OF VAR.
BHARAT HEAVY ELECTRICALS LTD. HARDWAR		DRN	BSN	Sd.	18.08.11	
		CHD	DDT	Sd.	18.08.11	
		APD	MKL	Sd.	10.10.11	
DEPT. HXE	SCALE	WEIGHT(Kg.)	REF. TO ASSY. DRG.		ITEM NO.	NO.OF ITEMS
CODE 4222	1:20	3850	21603170149		01	75, 77
TITLE			DRAWING NO.			
FLANGE 01			31603170243			
			SHEET NO. 01		NO.OF SHEETS 01	

COPYRIGHT AND CONFIDENTIAL
 THE INFORMATION ON THIS DOCUMENT IS THE PROPERTY OF
 BHARAT HEAVY ELECTRICALS LIMITED . IT MUST NOT BE USED DIRECTLY
 OR INDIRECTLY IN ANY WAY DETRIMENTAL TO THE INTEREST OF THE COMPANY.

DRAWING NO. 31603170244

50° THE REST.

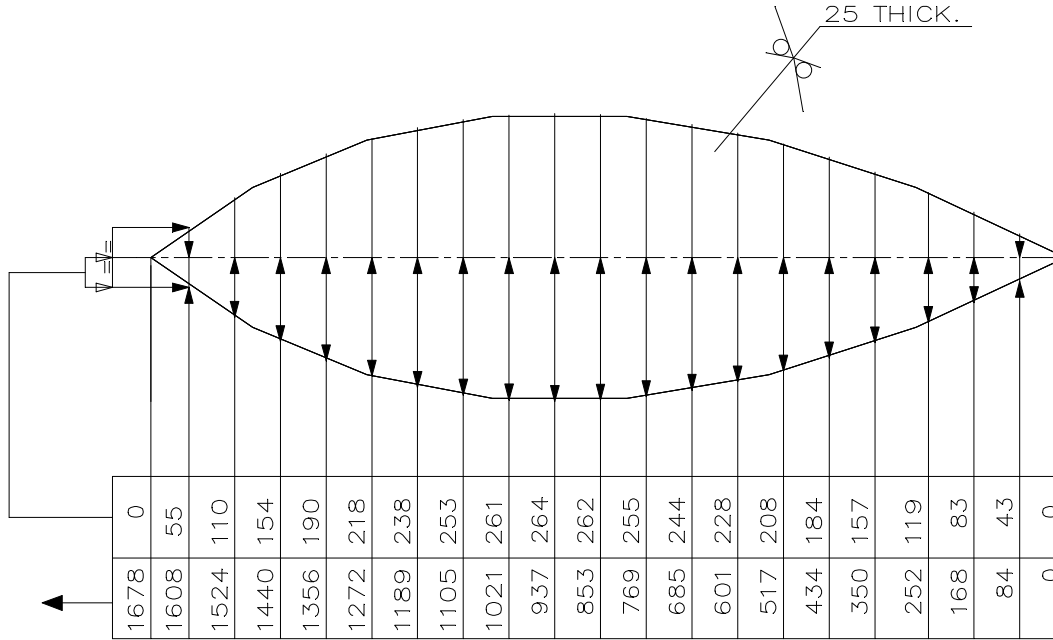

INVENTORY NO.	SIGN & DATE	REF. DRG NO.
---------------	-------------	--------------

GRADE OF UNTOL. DIM.: -		CBOM NO. 01603170062		STATUS OF DRG.		TYPE OF PRODUCT OR NAME OF CUSTOMER/ PROJECT													
M/CG- Y/φ/M/φ AA 0230208		WELDING- X/B/φ/φ-AA621104		GAS CUTTING-'T3'AA0621101		DRN		NAME		SIGN		DATE		NO.OF VAR.					
REV. DATE		ALTERED CHECKED		REV. DATE		ALTERED CHECKED		DEPT. HXE		SCALE		WEIGHT(Kg.)		REF. TO ASSY. DRG.		ITEM NO.		NO.OF ITEMS	
								4222		1:20		117		01603170062		12		75, 77	
TITLE										DRAWING NO.		SHEET NO.		NO.OF SHEETS					
PROFILING PLATE										31603170244		01		01					
										7		22		23		24			



COPYRIGHT AND CONFIDENTIAL
 THE INFORMATION ON THIS DOCUMENT IS THE PROPERTY OF
 BHARAT HEAVY ELECTRICALS LIMITED . IT MUST NOT BE USED DIRECTLY
 OR INDIRECTLY IN ANY WAY DETRIMENTAL TO THE INTEREST OF THE COMPANY.

DRAWING NO. 31603170245

50° THE REST.

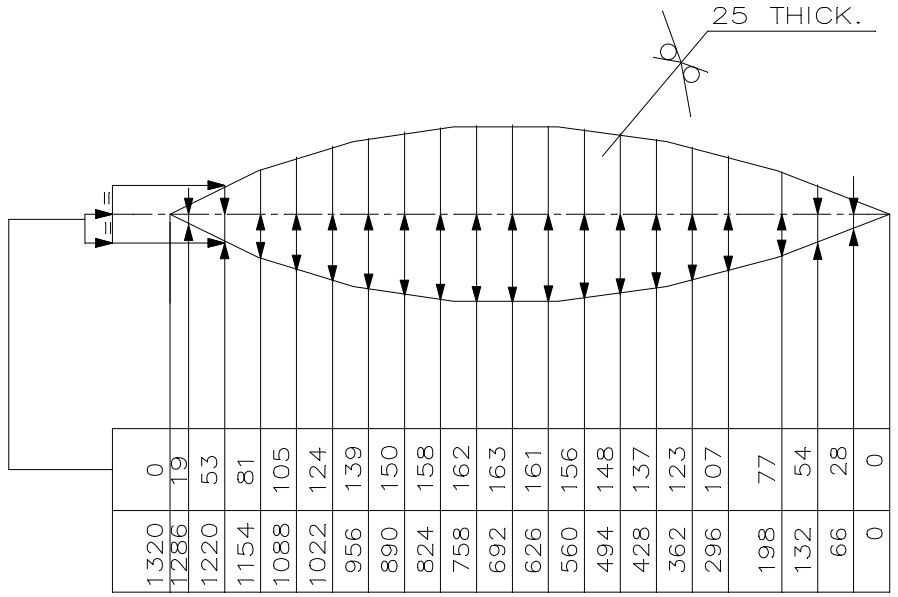

INVENTORY NO.	SIGN & DATE

GRADE OF UNTOL. DIM.: -		CBOM NO. 01603170062		STATUS OF DRG.	
M/CG- Y/φ/M/φ AA 0230208					
WELDING- φ/B/φ/φ-AA621104					
GAS CUTTING-'T3'AA0621101					
REV. DATE	ALTERED CHECKED	REV. DATE	ALTERED CHECKED		

TYPE OF PRODUCT OR NAME OF CUSTOMER/ PROJECT		DRN		NAME		SIGN		DATE		NO.OF VAR.	
		B.S.N.		Sd.		18.08.2011					
		CHD		D.D.T.		Sd.		18.08.2011			
		APD		M.K.L.		Sd.		10.10.2011		73 , 74	
DEPT. HXE		SCALE		WEIGHT(Kg.)		REF. TO ASSY. DRG.		ITEM NO.		NO.OF ITEMS	
CODE 4222		1:20		57		01603170062		13		75 , 77	
TITLE		1		3		DRAWING NO.					
PROFILING PLATE						31603170245					
						SHEET NO. 01		NO.OF SHEETS		01	

31603170246
No. 31603170246
AIBaklp saM#yaa/DRAWING

50 / THE REST

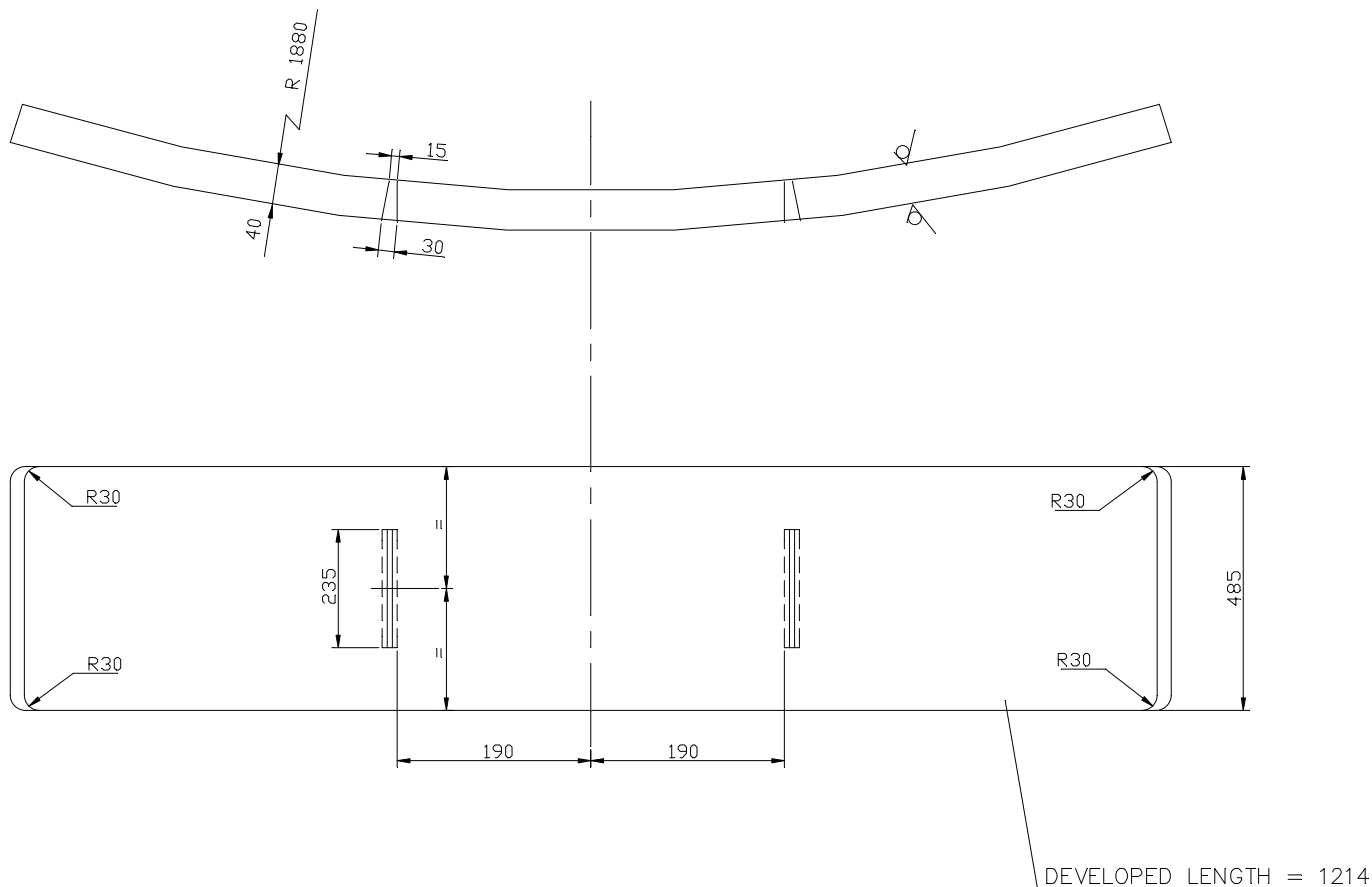

DEVELOPED LENGTH = 1214

COPYRIGHT AND CONFIDENTIAL THE INFORMATION ON THIS DOCUMENT IS THE PROPERTY OF BHARAT HEAVY ELECTRICALS LIMITED. IT MUST NOT BE USED DIRECTLY OR INDIRECTLY IN ANY WAY DETERMINAL TO THE INTEREST OF THE COMPANY.

swa%kafOkkar evaM gaonadiya [sa p'laak maom di gal- salanaaa Baart hova] looi@/kisa ilaima'aa ki sampika ho . Isaka p'xyaa yaa Ap'xyaa \$p maom . Iskal Bal trh p'yacaga nahM ikyaa jaae jaae kmpnadi ko tht maom haimakar haa .

saM#yaa saM#yaa/INVENTORY NO. saM#yaa saM#yaa/REFERENCE DRG. NO. saM#yaa saM#yaa/DATE

Asa*ya ivamaaAaoM ka vaga- GRADE OF UNTOLERANCED DIMENSION		sal*bal*Aao*ema*/C.B.O.M. 01603170062		AIBaklp ka str STATUS OF DRG.]Paad ka p'kar yaa ga'ahkApiryaaajanaa ka naama TYPE OF PRODUCT OR NAME OF					
maSalinaMga ? ee0230208 ema MACHINING - AA0230208 m		sahmat ivabaaga AGREED DEPTT. naama/NAME		idnaMk/DATE		CUSTOMER/PROJECT					
vaaiiDMMGga ? ee0621104 ki EaoNal ba WELDING-CLASS 'B' OF AA0621104		WT. J.K.		SD/- 10.10.11		Bharat Nova [labi@/kisa ilaimaTad? ranalpur? hirWar BHARAT HEAVY ELECTRICALS LIMITED RANIPUR, HARDWAR Andupat/SCALE					
gaOsa kiTMGga ? ee0621101 ki saarNal 3		saM#yaa saM#yaa/REV.		DATE		saM#yaa saM#yaa/REV.		DATE		naama/NAME hstaxar/SIGN idnaMk/DATE	
GAS CUTTING TABLE-3 OF AA0621101		saM#yaa saM#yaa/REV.		DATE		saM#yaa saM#yaa/REV.		DATE		vaivent saM#yaa No. of Var.	
ivaBaaga DEPTT. HXE		kaod\CODE 4222		1:5		Baar ik'ga'a WEIGHT (KG) 184		Asaambalal AIBaklp ka saM#yaa- REFER TO ASSLY. BRG. 01603170062		naga EmaMk ITEM NO. OF ITEMS	
SaYa-k/TITLE PAD						kaD-AIBaklp saM#yaa/DRAWING NO. 7, 31603170246		pRyZ saM#yaa/Sheets 01		pRyZaom ki saM#yaa/No. of Sheets 22 23 24 01	

DRAWING NO. 31603470027

50 THE REST.

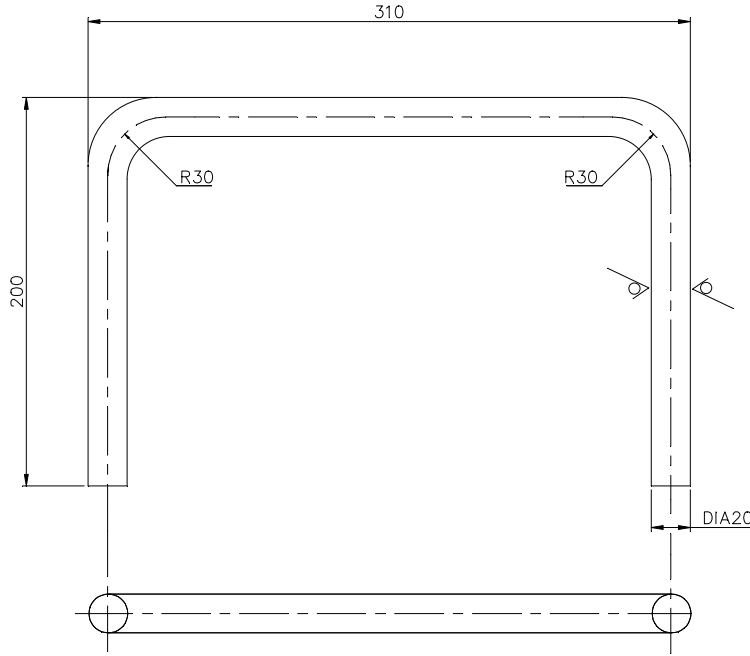

DEVELOPEMENT LENGTH = 645

NOTE: -

THE SOFT COPY OF PROFILE TO BE FLAME CUT IS IN 1:1 SCALE.

INVENTORY NO. SIGN & DATE REF. DRG NO. COPYRIGHT AND CONFIDENTIAL THE INFORMATION ON THIS DOCUMENT IS THE PROPERTY OF BHARAT HEAVY ELECTRICALS LIMITED. IT MUST NOT BE USED DIRECTLY OR INDIRECTLY IN ANY WAY DETRIMENTAL TO THE INTEREST OF THE COMPANY.

GRADE OF UNTOL. DIM.: -		CBOM NO. 01603470012		STATUS OF DRG.		TYPE OF PRODUCT OR NAME OF CUSTOMER/ PROJECT				500 MW				
M/CG- V/C/M/F AA 0230208		AGREED DEPT.	NAME	SIGN	DATE	BHARAT HEAVY ELECTRICALS LTD. HARDWAR				DRN	NAME	SIGN	DATE	NO.OF VAR.
WELDING-A/B/C/D-AA621104						DEPT. HXE				CHD	DDT	Sd.	14.6.03	
GAS CUTTING-'T3'AA0621101						CODE 4222				APD	NPM	Sd.	16.6.03	73, 74
REV. DATE	ALTERED	REV. DATE	ALTERED	BSNegi		SCALE				WEIGHT(Kg.)	REF. TO ASSY. DRG.	ITEM NO.	NO.OF ITEMS	
	CHECKED	02	16.6.03	CHECKED	NPM	-				1.650	01603470012	44	75, 77	
		HXE-03-F1023				TITLE				DRAWING NO. 31603470027				
		HARD COPY REPLACED BY SHOFT COPY				LADDER ARM				SHEET NO. 01 NO.OF SHEETS 01				

DRAWING NO. 31603470067

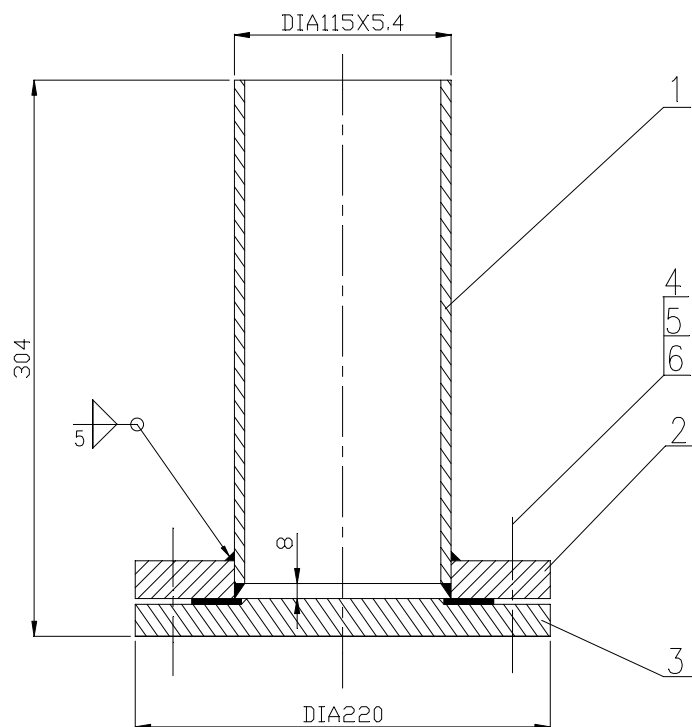

TECHNICAL REQUIREMENTS: -

01. VISUAL INSPECTION OF WELD SEAMS AS PER PS HW0620099. CLASSIFICATION GROUPS:-CS/CK
02. NON DESTRUCTIVE EXAMINATION OF WEL SEAMS AS PER PS HW0850199 PART-10
03. THE GENERAL TOLERANCES OF STRAIGHTNESS, FLATNESS AND PARALLELISM SHALL BE MAINTAINED AS PER AA0621105 GRADE-F.

COPYRIGHT AND CONFIDENTIAL
 THE INFORMATION ON THIS DOCUMENT IS THE PROPERTY OF
 BHARAT HEAVY ELECTRICALS LIMITED . IT MUST NOT BE USED DIRECTLY
 OR INDIRECTLY IN ANY WAY DETRIMENTAL TO THE INTEREST OF THE COMPANY.

REF. DRG NO.

SIGN & DATE

INVENTORY NO.

14/10/94

HXE2-8270

GRADE OF UNTOL. DIM.: -		CBOM NO. 01603470026		STATUS OF DRG.		TYPE OF PRODUCT OR NAME OF CUSTOMER/ PROJECT								
M/GG - V/C/M/F AA-0230208		AGREED DEPT.	NAME	SIGN	DATE	BHARAT HEAVY ELECTRICALS LTD. HARDWAR								
WELDING - X/B/X/B-AA621104		WT	AKG	Sd/-	1.10.94					DRN	K.P.S.	Sd.		NO. OF VAR.
GAS CUTTING - T3'AA0621104										CHD	N.S.	Sd.	13.8.94	
REV.	DATE	ALTERED	BSNegi	REV.	DATE	ALtered	DEPT.	HXE	SCALE	WEIGHT (Kg.)	REF. TO ASSY. DRG.	ITEM NO.	NO. OF ITEMS	
		CHECKED		02	04.05.10	CHECKED		4222	N.T.S.	14.9	01603470026	07	75, 77	
			HXE-10-F0035	HARD COPY REPLACED BY SOFT COPY			TITLE DRAIN PIPE				DRAWING NO. 31603470067			
											SHEET NO. 01 NO. OF SHEETS 01		71 22 23 24	

SECTION A-A

50 / THE REST

31603470091

AlBaklp ka sM#yaa/DRAWING NO.

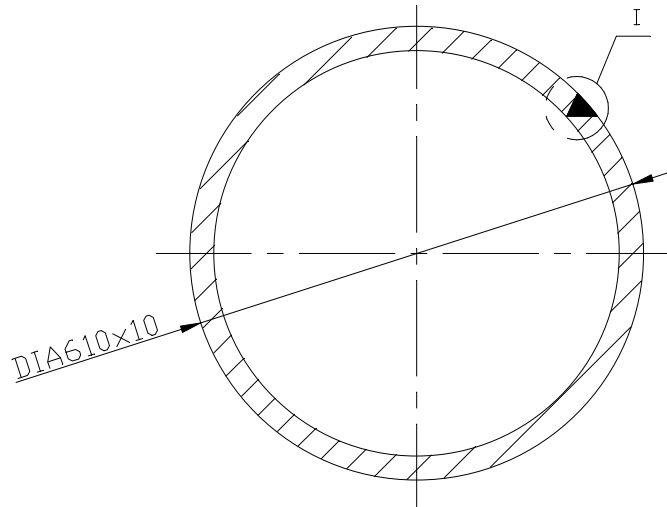
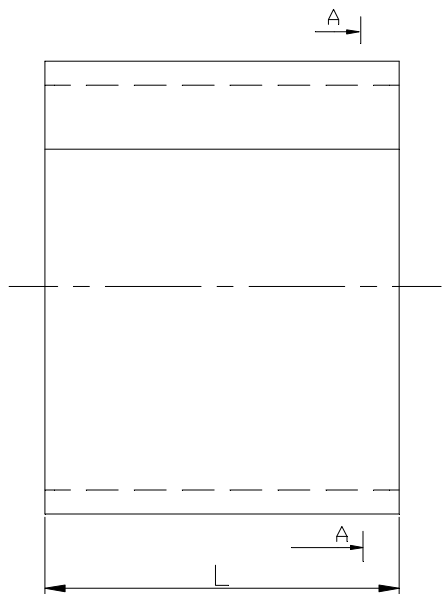

VAR.	L	WT.(Kg)
00	300	45
01	700	104

DETAIL-I

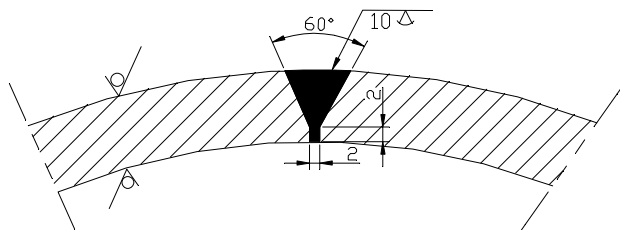

TECHNICAL REQUIREMENT

WELDING CLASSIFICATION GROUP ACCORDING TO HW0620099 CS.
 TEST SCOPE ACCORDING TO HW0850199.
 CATEGORY OF SERVICE REQUIREMENT-3
 NOTE:- DEVELOPED LENGTH = 1884.

saM#yaa/ INVENTORY NO.
 saM#yaa/ sM#yaa/ SIGN & DATE
 saM#yaa/ AlBaklp ka sM#yaa/ REFERENCE DRG. NO.

Asa*yaa ivamaaAaoM ka vaga- GRADE OF UNTOLERANCED DIMENSION		sal*bal*Aao*ema*/C.B.O.M. 01603470036		AlBaklp ka sM#yaa/ STATUS OF DRG.]PaaD ka p'kar yaa		2X250 MW NEYVELI	
maSalinaMga ? ee0230208 ema MACHINING - AA0230208 m		saM#yaa/ AGREED DEPTT. naama/NAME		idnaMk/DATE		ga'ahkApiryaaajanaa ka naama		TYPE OF PRODUCT OR NAME OF	
vaaiIDMMGga ? ee0621104 ki EaoNal ba WELDING-CLASS 'B' OF AA0621104		WT I RAM		sd/- 23.09.06		CUSTOMER/PROJECT		naama/NAME hstaxar/SIGN idnaMk/DATE	
gaOsa kiTMGga ? ee0621101 ki saarNal 3		saM#yaa/ REV. DATE		saM#yaa/ REV. DATE		Bharat Heavy Electricals Limited		LEKH RAM Sd/- 16/09/06	
GAS CUTTING TABLE 3 OF AA0621101		saM#yaa/ REV. DATE		saM#yaa/ REV. DATE		RANIPUR, HARDWARE		NP Sd/- 18/09/06	
HXE-12-F0206		HXE-08-F0052		MANOJ MKL		Andapat/SCALE		NPM Sd/- 25/09/06	
VAREANT 01 ADDED.		CHANGE DONE AS MARKED 01		SaYa-k/TITLE		PIPE		Asaambalal AiBaklp ka saM#yaa/ REFER TO ASSLY DRG. 31603470040	
10 Δ WELDING		1.94 LENGTH, M		1.56 WEIGHT(KG)		Baar ik'ga'a WEIGHT (KG) 45.0		naga EmaMk ki saM#yaa/ NO. OF ITEMS	
						kaD\ CODE 7		AlBaklp saM#yaa/DRAWING NO. 31603470091	
						p'Yz saM#yaa/Sheets No.		p'RYzaoM ki saM#yaa/No. of Sheets	

COPYRIGHT AND CONFIDENTIAL THE INFORMATION ON THIS DOCUMENT IS THE PROPERTY OF BHARAT HEAVY ELECTRICALS LIMITED. IT MUST NOT BE USED DIRECTLY OR INDIRECTLY IN ANY WAY DETERIMENTAL TO THE INTEREST OF THE COMPANY.

swa%kaolokar evaM gaocanaIya [sa p'laok maom di gal- sulanaaa Baart hova [lool@/kisa ilaima'oo ki sampica ho . Isaka p'xyaa yaa Ap'xyaa \$p maom iksal Bal trh p'yacaga nahM ik'ya paa paa kmpnaal ko th maom haimakar haa .

31603470109

AiBaklp saM#yaa/DRAWING NO.

50 / THE REST

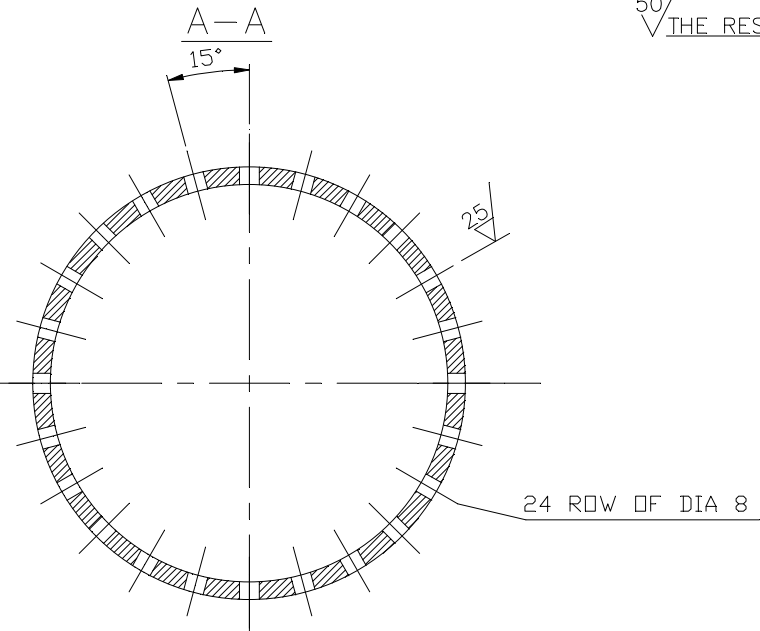
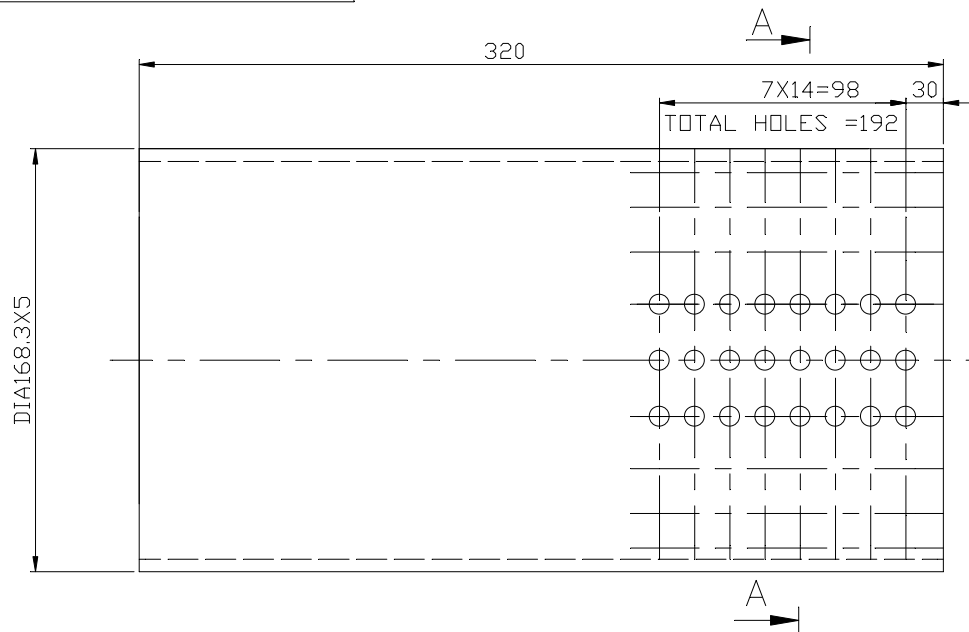

swa%kaofokar evaM gaonadiya
 [sa p'laok maom di gal- salucanaa Baart
 hovaI [looi@/klsa ilaimaTad ki sampica ho
 . Isaka p'xyaa yaa Ap'xyaa \$p maom
 ikasal Bal trh p'yacaga nahM ikya paae
 paae kmpnaI ko trh maom haimakr haa .

swaMiba-t Aibaklp
 saM#yaa
 REFERENCE DRG. NO.
 HXE 2-3638
 INVENTORY NO.

Asa*ya ivamaaAaom ka vaga- GRADE OF UNTOLERANCED DIMENSION		sal*bal*Aao*ema*/C.B.O.M. 01603170062		Aibaklp ka str STATUS OF DRG.]P%Paad ka p'kar yaa ga'ahkApiryaaajanaa ka naama TYPE OF PRODUCT OR NAME OF					
maSalinaMga ? ee0230208 ema MACHINING - AA0230208 m		sahimat iwaBaaga AGREED DEPTT.		naama/NAME		hstaxar/ SIGN.		idnaMk/DATE]P%Paad ka p'kar yaa ga'ahkApiryaaajanaa ka naama TYPE OF PRODUCT OR NAME OF	
vaaiIDMMGga ? ee0621104 ki EaoNal ba WELDING-CLASS 'B' OF AA0621104		WT		J.K.		sd/-		07.03.12		CUSTOMER/PROJECT Bhart hovaI [abi@/klsa ilaimaTad ranalpur? hirWar BHARAT HEAVY ELECTRICALS LIMITED RANIPUR, HARDWAR Andupat/SCALE	
gaOsa kiTMGga ? ee0621101 ki saarNal 3		saMsaooQaridnaMk REV. DATE		saMsaooQaridnaMk REV. DATE		saMsaooQaridnaMk REV. DATE		saMsaooQaridnaMk REV. DATE		naama/NAME	
GAS CUTTING TABLE-3 OF AA0621101		ALTERED BY jacoBkta- CHD		ALTERED BY jacoBkta- CHD		ALTERED BY jacoBkta- CHD		ALTERED BY jacoBkta- CHD		naama/NAME	
										T.BASNAL	
										S.KANT	
										05.03.2012	
										11.03.2012	
										05.03.2012	
										11.03.2012	
										05.03.2012	
										11.03.2012	
										05.03.2012	
										11.03.2012	
										05.03.2012	
										11.03.2012	
										05.03.2012	
										11.03.2012	
										05.03.2012	
										11.03.2012	
										05.03.2012	
										11.03.2012	
										05.03.2012	
										11.03.2012	
										05.03.2012	
										11.03.2012	
										05.03.2012	
										11.03.2012	
										05.03.2012	
										11.03.2012	
										05.03.2012	
										11.03.2012	
										05.03.2012	
										11.03.2012	
										05.03.2012	
										11.03.2012	
										05.03.2012	
										11.03.2012	
										05.03.2012	
										11.03.2012	
										05.03.2012	
										11.03.2012	
										05.03.2012	
										11.03.2012	
										05.03.2012	
										11.03.2012	
										05.03.2012	
										11.03.2012	
										05.03.2012	
										11.03.2012	
										05.03.2012	
										11.03.2012	
										05.03.2012	
										11.03.2012	
										05.03.2012	
										11.03.2012	
										05.03.2012	
										11.03.2012	
										05.03.2012	
										11.03.2012	
										05.03.2012	
										11.03.2012	
										05.03.2012	
										11.03.2012	
										05.03.2012	
										11.03.2012	
										05.03.2012	
										11.03.2012	
										05.03.2012	
										11.03.2012	
										05.03.2012	
										11.03.2012	
										05.03.2012	
										11.03.2012	
										05.03.2012	
										11.03.2012	
										05.03.2012	
										11.03.2012	
										05.03.2012	
										11.03.2012	
										05.03.2012	
										11.03.2012	
										05.03.2012	
										11.03.2012	
										05.03.2012	
										11.03.2012	
										05.03.2012	
										11.03.2012	
										05.03.2012	
										11.03.2012	
										05.03.2012	
										11.03.2012	
										05.03.2012	
										11.03.2012	
										05.03.2012	
										11.03.2012	
										05.03.2012	
										11.03.2012	
										05.03.2012	
										11.03.2012	
										05.03.2012	
										11.03.2012	
										05.03.2012	
										11.03.2012	
										05.03.2012	
										11.03.2012	
										05.03.2012	
										11.03.2012	
										05.03.2012	
										11.03.2012	
										05.03.2012	
										11.03.2012	
										05.03.2012	
										11.03.2012	
										05.03.2012	
										11.03.2012	
										05.03.2012	
										11.03.2012	
										05.03.2012	
										11.03.2012	
										05.03.2012	
										11.03.2012	
										05.03.2012	
										11.03.2012	
										05.03.2012	
										11.03.2012	
										05.03.2012	
										11.03.2012	
										05.03.2012	
										11.03.2012	
										05.03.2012	
										11.03.2012	
										05.03.2012	
										11.03.2012	
										05.03.2012	
										11.03.2012	
										05.03.2012	
										11.03.2012	
										05.03.2012	
										11.03.2012	
										05.03.2012	
										11.03.2012	
										05.03.2012	
										11.03.2012	
										05.03.2012	
										11.03.2012	
										05.03.2012	
										11.03.2012	
										05.03.2012	
										11.03.2012	
										05.03.2012	
										11.03.2012	
										05.03.2012	
										11.03.2012	
										05.03.2012	
										11.03.2012	
										05.03.2012	
										11.03.2012	
										05.03.2012	
										11.03.2012	
										05.03.2012	
										11.03.2012	
										05.03.2012	
										11.03.2012	
										05.03.2012	
										11.03.2012	
										05.03.2012	
										11.03.2012	

3-165-01-70181
DRAWING NO.

12.5
ALL OVER

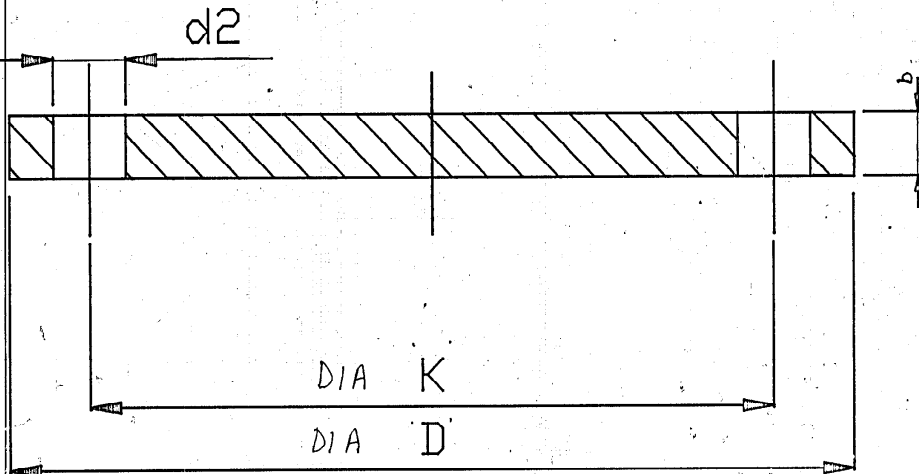

VAR	NOM SIZE	FLANGE DIMENSIONS				BOLTING DETAILS				CODE NO.	WT.
		D		b		BOLT SIZE	HOLES		P.C.D K		
		NOM	TOL	NOM	TOL		NO.	d2			
01	10	90		14		M12	4	14	60	AA1011819155	0.63
02	15	95		14		M12	4	14	65	AA1011819155	0.72
03	20	105		16		M12	4	14	75	AA1011819155	1.02
04	25	115		16		M12	4	14	85	AA1011819155	1.23
05	32	140		16		M16	4	18	100	AA1011819155	1.8
06	40	150	+1	16		M16	4	18	110	AA1011819155	2.09
07	50	165		18		M16	4	18	125	AA1011819163	2.88
08	65	195		18		M16	4	18	145	AA1011819163	3.66
09	80	200		20		M16	8	18	160	AA1011819163	4.77
10	100	220		20		M16	8	18	180	AA1011819163	5.65
11	125	250	+1.5	22		M16	8	18	210	AA1011819173	8.42
12	150	265		22		M20	8	22	240	AA1011819171	10.40
13	175	315		24	+3	M20	8	22	270	AA1011819171	14.00
14	200	340		24	-0	M20	12	22	295	AA1011819171	16.10
15	250	405		26		M24	12	26	335	AA1011819180	24.90
16	300	460		28		M24	12	26	410	AA1011819180	35.10
17	350	520		30		M24	16	26	470	AA1011819198	47.8
18	400	580	+2	32	+5	M27	16	30	525	AA1011819198	63.50
19	500	715		36	-0	M30	20	33	650	AA1011819201	102.00

MATERIAL SPECN. = AA10119

VAR. 00	REMARKS	ITEM NO.	DESCRIPTION	DRAWING NO.	MATERIAL CODE	UNIT WEIGHT													
59	64-65	75	25	27	29	58	69	60	77	32	33	46	54	55	56	57	66	71	72

CARD TYPE 3 28 → 28 → CARD TYPE-1 28 → CARD TYPE-2

REF. DRG. NO.
 INVENTORY NO. HX2-7959
 SIGN & DATE 13/13/94

GMS NO./GR. SP. NO. 8-165-01-70016		STATUS OF DRG.		TYPE OF PRODUCT OR NAME OF CUSTOMER / PROJECT	
AGREED DEPT.	NAME	SIGN	DATE	BPHARAT HEAVY ELECTRICALS LTD. HARDWAR.	
WT	I. Ram	[Signature]	26.2.94	DRN	GARG RIK
GRADE OF UNTOL. DIM. —		M/CG-C/M/F AA 0230208		CHD	S K B
WELDING -A/B/C/D AA0621104		GAS CUTTING 'T3' AA0621101		APD	K N M
REV/DATE	ALTERED CHECKED	REV/DATE	ALTERED CHECKED	DEPT. HXE	SCALE
				CODE 4222	NTS
REV. DATE		ALTERED CHECKED		WEIGHT (kg)	REF. TO ASSY. DRG.
				SEE BOM	
TITLE				DRAWING NO.	
BLANK FLANGE				3-165-01-70181	
PNOM 16 KG/cm ²				SHEET NO. 01 / NO. OF SHEETS 01	

3-165-01-70182
DRAWING NO

12.5
ALL OVER

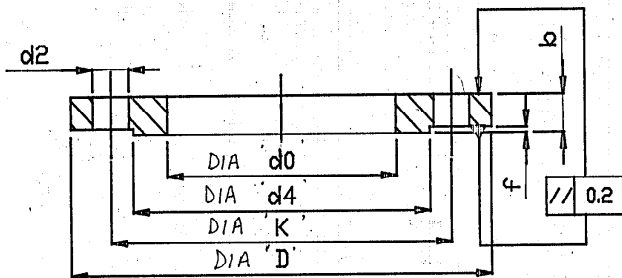

VAR	NOM SIZE	FLANGED DIMENSIONS						BOLTING DETAILS					CODE NO./SPC.N.	WT.		
		d0		D		b		RAISED FACE		BOLT SIZE	HOLES				P.C.D K	
		NOM	TOL.	NOM	TOL.	NOM	TOL.	d ₁	TOL.		f	NO.				d2
01	10	17.7		90		14		40		2	M12	4	14	60	AA1011819155/AA10119	0.53
02	15	21.8		95		14		45		2	M12	4	14	65	AA1011819155/AA10119	0.59
03	20	27.4		105		16		58		2	M12	4	14	75	AA1011819155/AA10119	0.85
04	25	34.2		115		16		68	+0.0	2	M12	4	14	85	AA1011819155/AA10119	1.01
05	32	42.9	+0.5	140	+1	16		78	-1.0	2	M16	4	18	100	AA1011819155/AA10119	1.47
06	40	48.8	-0.0	150		16		88		3	M16	4	18	110	AA1011819155/AA10119	1.61
07	50	60.8		165		18		102		3	M16	4	18	125	AA1011819163/AA10119	2.18
08	65	76.6		185		18		122		3	M16	4	18	145	AA1011819163/AA10119	2.67
09	80	89.9		200		20		138		3	M16	8	18	160	AA1011819163/AA10119	3.28
10	100	115.3		220		20		158		3	M16	8	18	180	AA1011819163/AA10119	3.62
11	125	140.7		250	+1.5	22		138		3	M16	8	18	210	AA1011819171/AA10119	4.99
12	150	169.3		285		22		212		3	M20	8	22	240	AA1011819171/AA10119	6.00
13	175	194.7	+1.0	315	-0.0	24	+3	242	+0.0	3	M20	8	22	270	AA1011819171/AA10119	7.82
14	200	221.1	-0.0	340		24	-0	268	-2.0	3	M20	8	22	295	AA1011819171/AA10119	8.56
15	250	273.0		395		26		320		3	M20	12	22	350	AA1011819180/AA10119	11.10
16	300	325.9		445		26		370		4	M20	12	22	400	AA1011819180/AA10119	12.20
17	350	357.8		505		28		430		4	M20	16	22	460	AA1011819180/AA10119	16.00
18	400	408.4	+1.5	565	+2	32		482	+0.0	4	M24	16	26	515	AA1011819198/AA10119	26.10
19	500	510.0	-0.0	670		38	+5	585	-3.0	4	M24	20	26	620	AA1011819201/AA10119	38.80
20	600	612.6		780		42	-0	685		5	M27	20	30	725	AA1011819228/AA10119	52.00

THE INFORMATION ON THIS DOCUMENT IS THE PROPERTY OF BHARAT HEAVY ELECTRICALS LIMITED IT MUST NOT BE USED DIRECTLY OR INDIRECTLY IN ANY WAY DETRIMENTAL TO THE INTEREST OF THE COMPANY

VAR. 00	REMARKS	ITEM NO.	DESCRIPTION	STD	DRAWING NO.	MATERIAL CODE	UNIT WEIGHT
59	64	65	75	25	27	29	58
60	61	62	63	64	65	66	67
68	69	70	71	72	73	74	75

GMS NO./GR. SP. NO. 8-165-01-70016
 STATUS OF DRG.
 TYPE OF PRODUCT OR NAME OF CUSTOMER / PROJECT

GRADE OF UNTOL. DIM. --
 M/CG-C/M/F AA 0230208
 WELDING-A/B/C/D AA0621104
 GAS CUTTING T3 AA0621101

REV. DATE ALTERED CHECKED
 NAME SIGN DATE
 I. Ram 26.2.99

DEPT. HXE CODE 4222
 SCALE NTS
 WEIGHT (kg) SEE BOM

BHARAT HEAVY ELECTRICALS LTD. HARDWAR.

DRN GARG RK F.Y.
 CHD SK B 16.2.99
 APD K N M 12.3.99

TITLE PLT FLANGE PNOM 10 KG./cm²

DRAWING NO. 3-165-01-70182
 SHEET NO. 01 | NO. OF SHEETS 01

NO. OF VAR. 73/74
 NO. OF ITEMS 75/77

SIZE A3

INVENTORY NO. 7958
 REF. DRG. NO.
 SIGN & DATE 2/13/99

FIRST ANGLE PROJECTION (ALL DIMENSIONS ARE IN mm)

The information on this document is the property of BHARAT HEAVY ELECTRICALS LIMITED. It must not be used directly or indirectly in anyway detrimental to the interest of the company.

REV	DATE	ALTERED	REV	DATE	ALTERED	GMS 9-160-15-70001			
		CHECKED			CHECKED	AGREED DEPT	NAME	SIGN	DATE
						W.T.	GARG	GARG	11-3-80

50/ ALL OVER

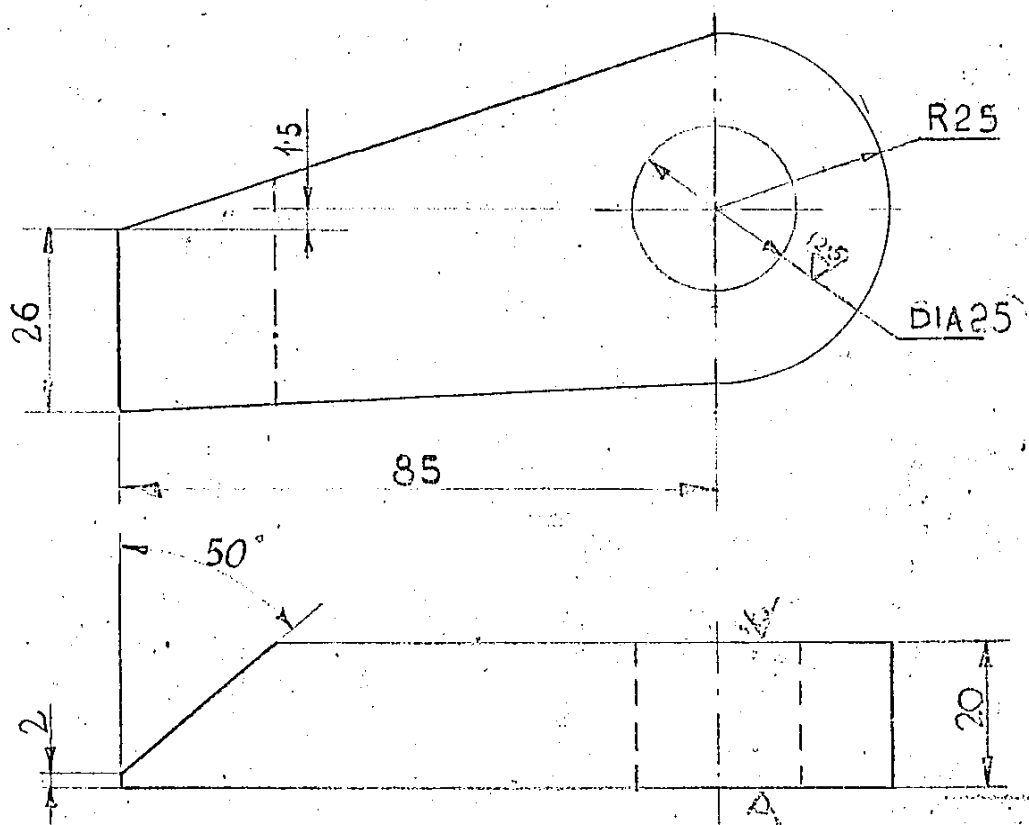

QTY	NO OF	UNIT OF	LUG	ITEM NO	DRAWING NO.	AA10119	0.38	UNIT WT (KG)	ITEM NO
VARI ANT	VARI ANT	RM. UNIT QTY				MATERIAL CODE	UNIT WT (KG)		
						MATERIAL SPECN.	QTY		

CARD TYPE 2 ← → CARD TYPE 1

DG-39  **BHARAT HEAVY ELECTRICALS LTD.**
RANIPUR - HARDWAR.

DEPT	CODE	SCALE	WEIGHT (KG)	REF. TO ASSY. DRG.	ITEM NO.
HXE	4222	1:1		2-160-15-70001	003
LUG			NAME	SIGN.	DATE
			DRAWN	ANMAD	
			CHECKED	L. SRINASTAV	
Dimensions to be Controlled Within Limits as Shown Machining Tolerance ± .25 mm Unless Otherwise Shown. Non Machining Tolerance ±			APPROVED	A. SINGH	
			DRAWING NO.		

Inventory No. 1422-650	SHEET NO. 1	NO. OF SHEETS. 1	SIZE A4

FIRST ANGLE PROJECTION

(ALL DIMENSIONS ARE IN mm) FORM DG 39(B)

REV	DATE	ALTERED	REV	DATE	ALTERED	RK GARG	CBOM No.		STATUS	
		CHECKED	01	22.11.03	CHECKED	MK LAHOTI	GMS 91601570001		OF DRG	
			HXE-03-F-1063				AGREED	NAME	SIGN	DATE
			HARD COPY TO BE REPLACED BY SOFT COPY.				DEPT.	GARG	sd.	7.3.80
							W.T.			

GRADE OF UNTOL.DIM.M/CGC/M/F.AA0230208 | WELDING A/B/C/D AA0621104 | GAS CUTTING-T3 AA0621101

50 THE REST.

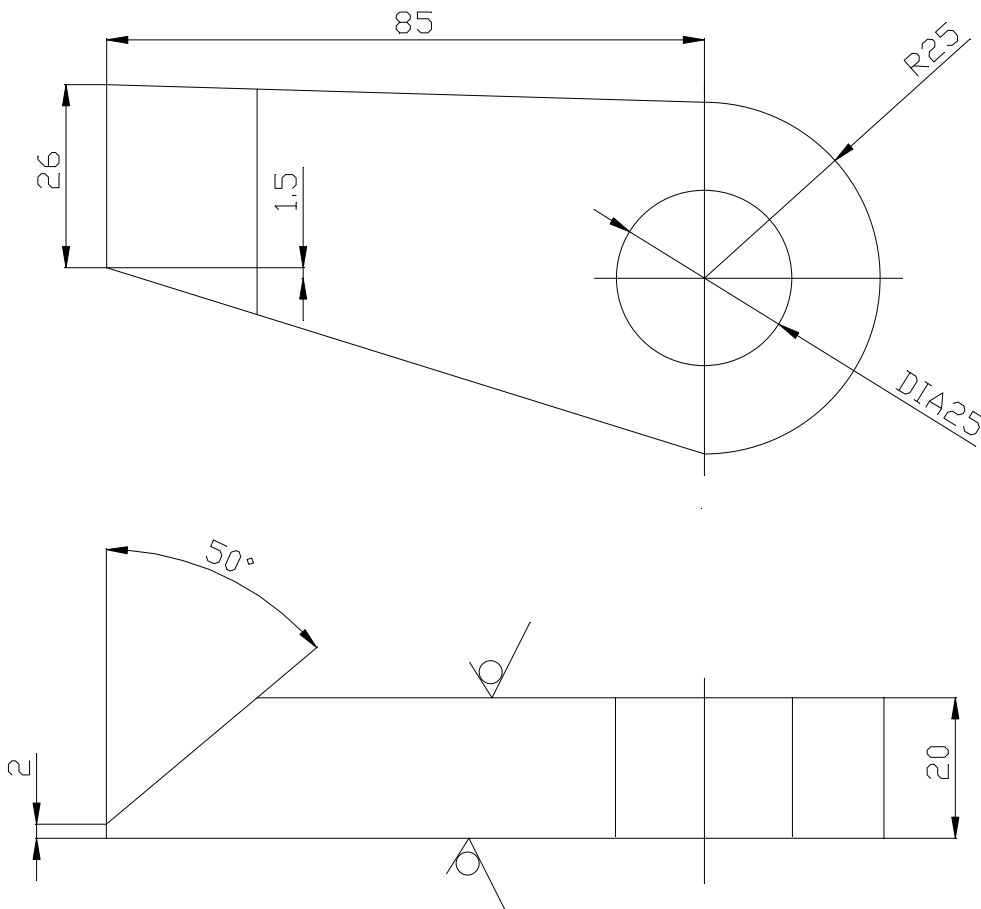

COPYRIGHT AND CONFIDENTIAL THE INFORMATION ON THIS DOCUMENT IS THE PROPERTY OF BHARAT HEAVY ELECTRICALS LIMITED. IT MUST NOT BE USED DIRECTLY OR INDIRECTLY IN ANY WAY DETRIMENTAL TO THE INTEREST OF THE COMPANY.

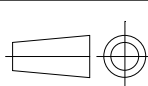
SIGN & DATE	REF.DRG.No.	 BHARAT HEAVY ELECTRICALS LTD HARDWAR		DRN	NAME	SIGN	DATE	NO. OF VAR
		CHD	L.K.S.	sd	21.2.80			
APD	A.SINGH	sd	22.2.80					
INVENTORY No.	DEPT. HXE		SCALE	WEIGHT(Kg)	REF.TO ASSY.DRG.	ITEM No.	No OF ITEMS	
	CODE 4222		-	0.38	21601570001	04		
	TITLE				DRAWING No.			
LUG				41601570002				
				SHEET No. 01		No.OF SHEETS 01		

FIRST ANGLE PROJECTION

(ALL DIMENSIONS ARE IN mm) FORM DG 39(B)

REV	DATE	ALTERED	REV	DATE	ALTERED	CBOM No. 21603470040	STATUS OF DRG
		CHECKED			CHECKED		
						AGREED DEPT.	NAME
						WT.	I RAM
						SIGN	DATE
						sd/-	23.09.06

GRADE OF UNTOL.DIM.M/CGC/M/F.AA0230208 WELDING A/B/C/D AA0621104 GAS CUTTING-T3 AA0621101

12.5/
THE REST.

20 HOLES $\phi 26$ (Equally Spaced)

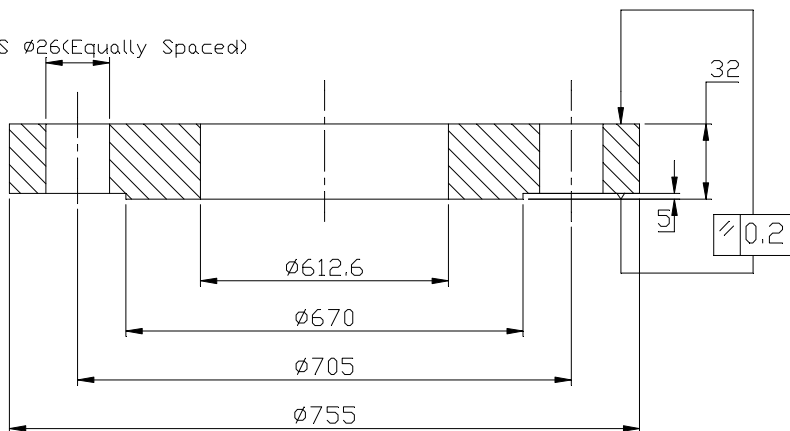

COPYRIGHT AND CONFIDENTIAL
THE INFORMATION ON THIS DOCUMENT IS THE PROPERTY OF BHARAT HEAVY
ELECTRICALS LIMITED. IT MUST NOT BE USED DIRECTLY OR INDIRECTLY IN
ANY WAY DETRIMENTAL TO THE INTEREST OF THE COMPANY.

REF.DRG.No.

SIGN & DATE

INVENTORY No.



BHARAT HEAVY ELECTRICALS LTD
HARDWAR

	NAME	SIGN	DATE	NO. OF VAR
DRN	RK	Sd.	16.9.06	
CHD	NP	Sd.	16.9.06	
APD	NPM	Sd.	25.9.06	

DEPT. HXE		SCALE -	WEIGHT(Kg) 93	REF. TO ASSY.DRG. -	ITEM No. -	No OF ITEMS
CODE 4222						

TITLE	PLATE FLANGE	DRAWING No.	41601570007
		SHEET No. 01	No.OF SHEETS 01

SIZE A4

FIRST ANGLE PROJECTION

(ALL DIMENSIONS ARE IN mm) FORM DG 39(B)

REV	DATE	ALTERED	REV	DATE	ALTERED	VIMAL	CBOM No.	STATUS
		CHECKED	01	27.6.13	CHECKED	SKB	21603470040	OF DRG
			HXE-13-F0135		AGREED DEPT.		NAME	SIGN
			DIM. 4670 6750 CORRECTED AS 670 & 750.		WT.		I RAM	sd/-
								23.09.06

GRADE OF UNTOL.DIM.M/CGC/M/F.AA0230208 WELDING A/B/C/D AA0621104 GAS CUTTING-T3 AA0621101

12.5/
THE REST.

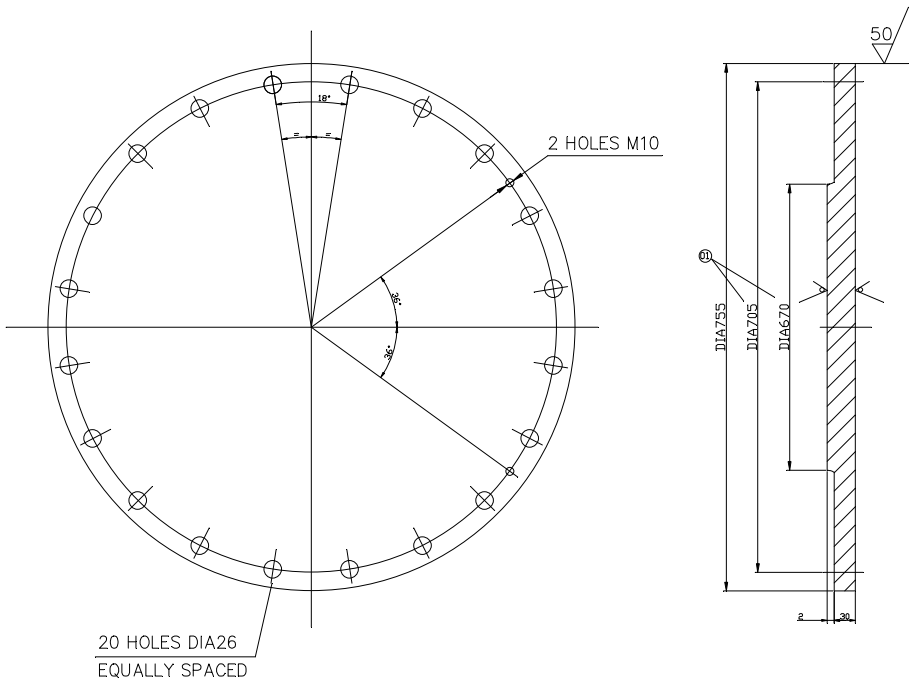

COPYRIGHT AND CONFIDENTIAL THE INFORMATION ON THIS DOCUMENT IS THE PROPERTY OF BHARAT HEAVY ELECTRICALS LIMITED. IT MUST NOT BE USED DIRECTLY OR INDIRECTLY IN ANY WAY DETRIMENTAL TO THE INTEREST OF THE COMPANY.

REF.DRG.No.

SIGN & DATE

INVENTORY No.

	BHARAT HEAVY ELECTRICALS LTD		DRN	RK	NAME	Sd.	DATE	16.9.06	NO. OF VAR
	HARDWAR		CHD	NP		Sd.	16.9.06		
			APD	NPM		Sd.	25.9.06		
DEPT. HXE		SCALE	WEIGHT(Kg)	REF. TO ASSY.DRG.	ITEM No.	No OF ITEMS			
CODE 4222		-	93	-	-	-			
TITLE				DRAWING No.					
BLANK FLANGE				41601570008					
		SHEET No. 01		No.OF SHEETS		01			

FIRST ANGLE PROJECTION

(ALL DIMENSIONS ARE IN mm) FORM DG 39(B)

REV	DATE	ALTERED	REV	DATE	ALTERED	CBOM No. 31603470068 var 01	STATUS OF DRG
		CHECKED			CHECKED		
						AGREED DEPT.	NAME
						WT.	sd/-
							23.09.06

GRADE OF UNTOL.DIM.M/CGC/M/F.AA0230208 WELDING A/B/C/D AA0621104 GAS CUTTING-T3 AA0621101

12.5/
ALL OVER

8 HOLES $\phi 18$ (Eq. Spaced)

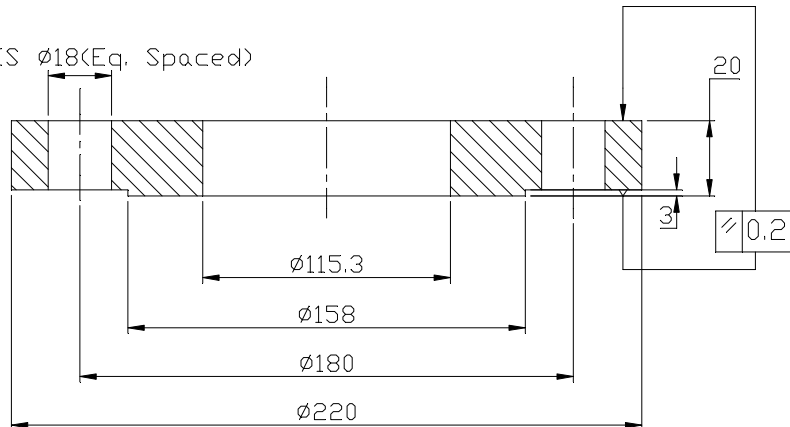

REF.DRG.No.

SIGN & DATE

INVENTORY No.



BHARAT HEAVY ELECTRICALS LTD
HARDWAR

	NAME	SIGN	DATE	NO. OF VAR
DRN	RKK	Sd.	16.9.06	
CHD	NP	Sd.	16.9.06	
APD	NPM	Sd.	25.9.06	

DEPT. HXE		SCALE	WEIGHT(Kg)	REF. TO ASSY.DRG.	ITEM No.	No OF ITEMS
CODE 4222		-	3.62	-	-	

TITLE	DRAWING No.
PLATE FLANGE	41603470006
	SHEET No. 01 No.OF SHEETS 01

COPYRIGHT AND CONFIDENTIAL
THE INFORMATION ON THIS DOCUMENT IS THE PROPERTY OF BHARAT HEAVY ELECTRICALS LIMITED. IT MUST NOT BE USED DIRECTLY OR INDIRECTLY IN ANY WAY DETRIMENTAL TO THE INTEREST OF THE COMPANY.

FIRST ANGLE PROJECTION

(ALL DIMENSIONS ARE IN mm) FORM DG 39(B)

REV	DATE	ALTERED	REV	DATE	ALTERED	CBOM No.		STATUS OF DRG	
		CHECKED			CHECKED	31603470068 var 01			
						AGREED DEPT.	NAME	SIGN	DATE
						WT.	IRAM	sd/-	23.09.06

GRADE OF UNTOL.DIM.M/CGC/M/F.AA0230208 WELDING A/B/C/D AA0621104 GAS CUTTING-T3 AA0621101

12.5/ ALL OVER

8 HOLES $\phi 18$ (Eq. Spaced)

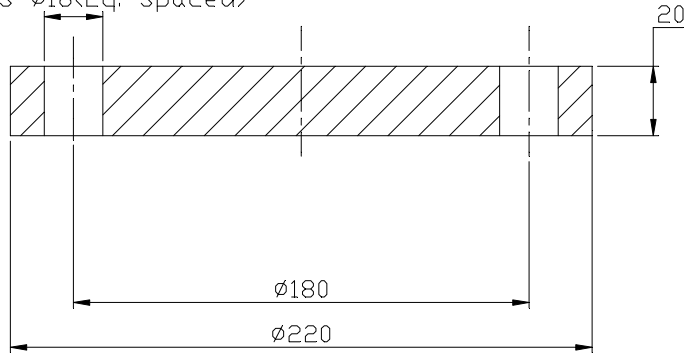

COPYRIGHT AND CONFIDENTIAL
THE INFORMATION ON THIS DOCUMENT IS THE PROPERTY OF BHARAT HEAVY ELECTRICALS LIMITED. IT MUST NOT BE USED DIRECTLY OR INDIRECTLY IN ANY WAY DETRIMENTAL TO THE INTEREST OF THE COMPANY.

REF.DRG.No.

SIGN & DATE

INVENTORY No.



BHARAT HEAVY ELECTRICALS LTD
HARDWAR

	NAME	SIGN	DATE	NO. OF VAR
DRN	RKK	Sd.	16.9.06	
CHD	NP	Sd.	16.9.06	
APD	NPM	Sd.	25.9.06	

DEPT. HXE		SCALE	WEIGHT(Kg)	REF. TO ASSY.DRG.	ITEM No.	No OF ITEMS
CODE 4222		-	-	-	-	-

TITLE	DRAWING No.
BLANK FLANGE	41603470007
SHEET No. 01 No.OF SHEETS 01	

प्रथम कोण प्रक्षेपण/FIRST ANGLE PROJECTION सभी विमाएं मिलिमीटर में हैं।/ALL DIMENSIONS ARE IN mm.

पत्र डीजी 39 (बी)
FORM 39 (B)

COPYRIGHT AND CONFIDENTIAL
 THE INFORMATION ON THIS DOCUMENT IS THE PROPERTY OF
 BHARAT HEAVY ELECTRICALS LIMITED. IT MUST NOT BE USED
 DIRECTLY OR INDIRECTLY IN ANY WAY DETERIMENTAL TO THE
 INTEREST OF THE COMPANY.

स्थायिकता एवं गोपनीय
 इस प्रलेख में दी गई सूचना भारत हेवी इलेक्ट्रिकल्स लिमिटेड की
 संपत्ति है। इसका प्रसारण या अप्रत्यक्ष रूप में किसी भी तरह
 प्रयोग नहीं किया जाए जो कम्पनी के हित में हानिकार हो।

संशोधन REV.	दिनांक DATE	संशोधनकर्ता ALTERED BY	संशोधन REV.	दिनांक DATE	संशोधनकर्ता ALTERED BY	सी.बी.ओ./C.B.O.M. 11603470059		अभिकल्प का स्तर STATUS OF DRG. U
		जांचकर्ता CHD			जांचकर्ता CHD	समस्त विभाग AGREED DEPTT.	नाम/NAME	हस्ताक्षर/ SIGN.
						वेल्डिंग टेक्नो.	पन्कज	ह.
मशीनिंग - एए0230208 एम MACHINING - AA0230208 m			वेल्डिंग - एए0621104 की श्रेणी बी WELDING - CLASS 'B' OF AA0621104			गैस कटिंग - एए0621101 की सारणी 3 GAS CUTTING-TABLE 3 OF AA0621101		

50 / THE REST.

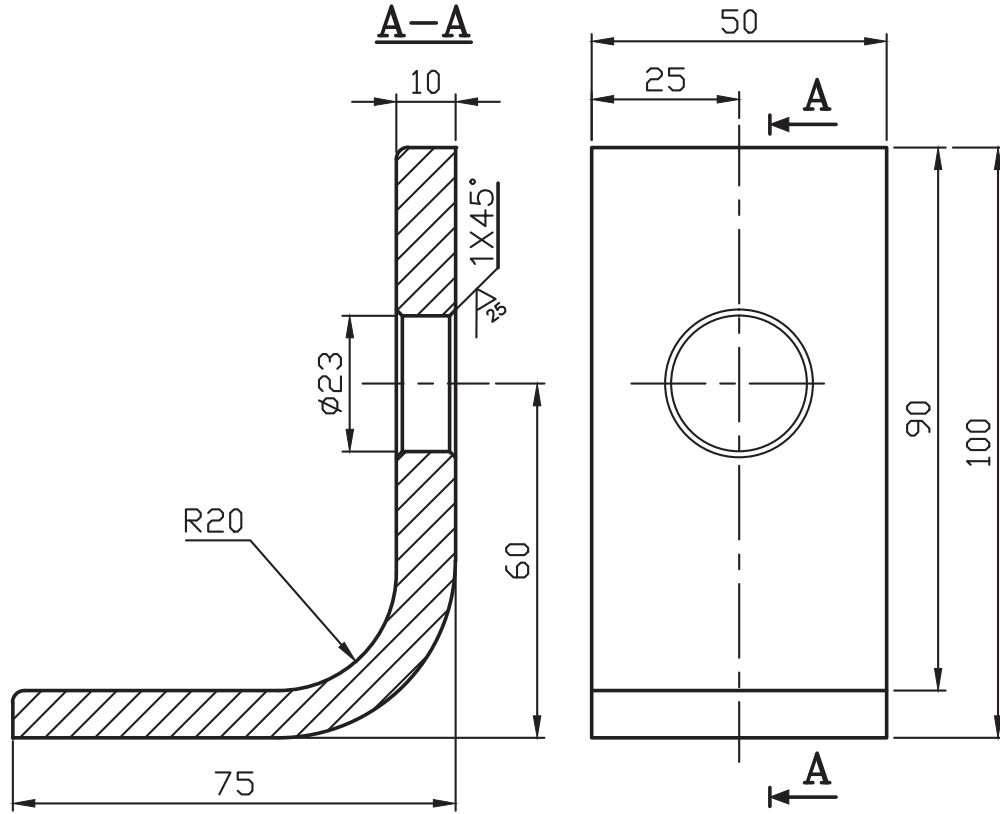

NOTE: -

1. SHARP EDGES TO BE ROUND OFF.
2. DEVELOPED LENGTH = 10x50x155.

स्वीकृत अभिकल्प संख्या REFERENCE DRG. NO.	भारत हेवी इलेक्ट्रिकल्स लिमिटेड, रानीपुर, हरिद्वार BHARAT HEAVY ELECTRICALS LIMITED, RANIPUR, HARDWAR		नाम/NAME	हस्ताक्षर/SIGN	दिनांक/DATE	वैकल्पिक संख्या No. of Var.
हस्ताक्षर और दिनांक/SIGN & DATE	विभाग DEPTT.	अनुपात/SCALE	भार कि.ग्रा. WEIGHT (KG)	असेम्बली अभिकल्प का संदर्भ REFER TO ASSLY. DRG.	नग क्रमांक ITEM NO.	नगों की संख्या NO. OF ITEMS
	HXE	1:1	0.60	11603470059	17	
शीर्षक/TITLE	कोड/CODE 4222		कार्ड कोड CARD CODE	अभिकल्प संख्या/DRAWING NO.		
			7	41603470008	22 23 24	
				पृष्ठ संख्या/Sheets No. 01	पृष्ठों की संख्या/No. of Sheets	01

FIRST ANGLE PROJECTION (ALL DIMENSIONS ARE IN mm)

01

REV. DATE	ALTERED	REV. DATE	ALTERED	QMS NO 9-160-45-70001	
01 27.3.15	Same	01 16/1/14		AGREED	NAME SIGN DATE
HXE-95-27		HXE-94-97		WT	GIRG
MATL CODE WAS AA1010212079 AA10112		MATL CODE B WAS HW10102120 SIAA10112			

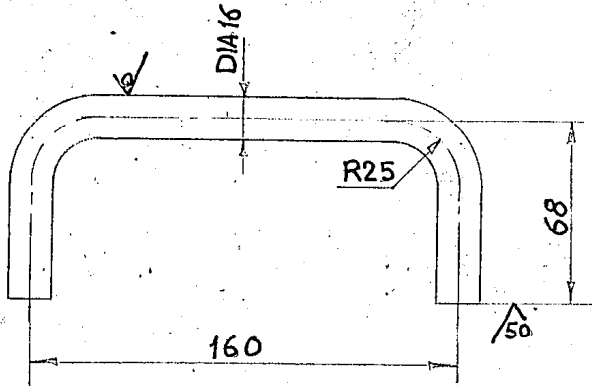

DEVELOPED LENGTH = 275

02

001		HANDLE	001		AA1010209086	0.44
66.64	64.63	53	52	31	23	16
QTY	NO	UNIT OF	DESCRIPTION	ITEM	DRAWING NO	MATERIAL CODE
66.64	64.63	53	52	31	23	16
VARI	NO	R.M UNIT	DESCRIPTION	ITEM	DRAWING NO	MATERIAL CODE
66.64	64.63	53	52	31	23	16
QTY	NO	UNIT OF	DESCRIPTION	ITEM	DRAWING NO	MATERIAL CODE
66.64	64.63	53	52	31	23	16
VARI	NO	R.M UNIT	DESCRIPTION	ITEM	DRAWING NO	MATERIAL CODE
66.64	64.63	53	52	31	23	16
QTY	NO	UNIT OF	DESCRIPTION	ITEM	DRAWING NO	MATERIAL CODE
66.64	64.63	53	52	31	23	16

BHARAT HEAVY ELECTRICALS LTD.
RANIPUR - HARDWAR.

DEPT	CODE	SCALE	WEIGHT (KG)	REF. TO ASSY. DRG.	ITEM NO.
HXE	043	1:2	0.44	3-160-45-70006	002
DRAWN	NAME	SIGN.	DATE		
CHECKED	M.L.L.	M.L.L.	6.3.14		
APPROVED	A.SINGH.		12.2.14		

HANDLE

Dimensions to be Controlled Within Limits as Shown
Machining Tolerance ± .25 mm Unless Otherwise
Shown. Non Machining Tolerance ±

CARD CODE: 4-160-45-70004

DRAWING NO. 4-160-45-70004

SHEET NO. 1 NO. OF SHEETS. 1

SIZE A4

The information on this document is the property of BHARAT HEAVY ELECTRICALS LIMITED. It must not be used directly or indirectly in anyway detrimental to the interest of the company.

