



PPX-BOI DEPARTMENT
BHARAT HEAVY ELECTRICALS LIMITED
HEEP: HARDWAR-249 403 (UTTRAKHAND)
TEL: +91 1334 28 4175 / 1786

Enquiry No.: B/4011/2022/0959/V1
Item: VARIABLE LOAD SPRING CAGES
Project: BUDGE-BUDGE
Enquiry Issue Date: 05/08/2022
Enquiry Due Date: 27/08/2022 (by 1345 HRS IST)

NIT: MATERIAL DETAILS AND INSTRUCTION TO BIDDERS

E-PROCUREMENT: Please note that this tender enquiry has been issued through BHEL's e-procurement portal developed by NIC (<https://eprocurebhel.co.in/>). Hence. PAPER BID or BID THROUGH E-MAIL SHALL NOT BE ENTERTAINED FOR THIS TENDER. Please upload your bid in BHEL's e-procurement portal developed by NIC (<https://eprocurebhel.co.in/>)

1 SCOPE OF ENQUIRY

Sealed Bids are invited from the bidders for the supply of the following items as per requirement mentioned below:

Sl. No.	Material Code & Item Description	Qty.	Project	Delivery Date
1	Material Code: W90313133468 VARIABLE LOAD SPRING CAGES AS PER DOC. NO. 313177A2550 (REV. 0), 413177A2501 (REV. 0) AND ST34004 REV. 08	01 SET (refer BOQ enclosed)	210 MW BUDGE-BUDGE	June-2023

Note: Evaluation will be done on basis of **Total Landed cost to BHEL upto Project site.**

2 PROJECT INFORMATION

Project Name	210 MW BUDGE-BUDGE
End Customer	M/s CESC LIMITED
Consignee Address	BUDGE-BUDGE GENERATING STATION STORES, PO-PUJALI, BUDGE-BUDGE 24 PGNS(S) BUDGE-BUDGE - 700 138, WEST BENGAL
Custom Duty Status	Free
Tax Structure	GST extra
Pls. note that the comparison would be done as per the applicable taxes and duties on the date of opening of Price Bid.	

3 EARNEST MONEY DEPOSITE (EMD)

Details	Amount In INR	Amount in Foreign Currency	Type
EMD	NIL	NIL	Refundable

4 PRE-QUALIFICATION REQUIREMENT (PQR)

The Pre-Qualification Requirements have been compiled and placed at **ANNEXURE-I**. All the bidders should ensure submission of complete details and documents as called for in the same. The offers submitted by the bidders would be scrutinized with respect to Pre-Qualification Requirements first. Techno-Commercial offer of only those bidders shall be evaluated who meet the Pre-Qualification Requirements.

	<p align="center">PPX-BOI DEPARTMENT BHARAT HEAVY ELECTRICALS LIMITED HEEP: HARDWAR-249 403 (UTTRAKHAND) TEL: +91 1334 28 4175 / 1786</p>	<p>Enquiry No.: B/4011/2022/0959/V1 Item: VARIABLE LOAD SPRING CAGES Project: BUDGE-BUDGE Enquiry Issue Date: 05/08/2022 Enquiry Due Date: 27/08/2022 (by 1345 HRS IST)</p>
---	--	---

5 SUBMISSION OF OFFER

Offers are to be uploaded on BHEL e-procurement portal developed by NIC (<https://eprocurebhel.co.in/>) in Two Parts and Part-I (Techno-Commercial Bid along with PQR, as detailed below) will be opened first. The offers are to be uploaded on or before the last date of submission of offer, as detailed on BHEL e-procurement portal for the tender.

In case of any difficulty faced on BHEL's e-Procurement portal, queries may be addressed to 0120-4001002, 0120-4001005 and 0120- 6277787 ; email: support-eproc@nic.in. These details are also available on 'Contact Us' page of the portal.

- 5.1 Only English version of all documents would be valid & binding.
- 5.2 Tenders are to be submitted in Two Parts and Part-I (Techno-Commercial Bid, as detailed below) will be opened first. The offers are to be submitted on or before the Due Date and time, as detailed below:

[A] COVER-1: PRE-QUALIFICATION REQUIREMENT (PQR) & TECHNO-COMMERCIAL BID

Comprising of following documents:

- a. Bidders are required to furnish requisite details and supporting documents as specified in **Pre-Qualification Requirements (PQR)** for meeting the same. Pre-Qualification requirements is as per enclosed **ANNEXURE-I**.
- b. Complete Technical offer with relevant documents etc. (as per specification attached as **ANNEXURE-II**).
- c. **NIT: MATERIAL DETAILS AND INSTRUCTION TO BIDDERS, SPECIAL TERMS & CONDITIONS OF ENQUIRY** and **GISTC (General Instructions and Standard Terms & Conditions against Tender Enquiry)** are an integral part of this enquiry and endorsed copies of these documents (duly signed and stamped on each page, as a token of acceptance) are to be necessarily submitted along with the offer. Deviations if any are to be listed out separately.
- d. Commercial Terms & Conditions.
- e. Any Deviation with reference to technical requirements/specification to be laid down on separate sheet. Acceptance of such technical deviations would be at the discretion of BHEL

[B] COVER-2: PRICE-BID

COVER-2 (PRICE BID) should be strictly submitted in BOQ excel (.xls) format uploaded with enquiry. Price bid of only techno-commercial acceptable bidders will be opened. **Techno-Commercial offer of only those bidders shall be evaluated who meet the Pre-Qualification Requirements mentioned in our Enquiry.**

- 5.3 All correspondence thereof, shall be addressed to the following persons:

<p>Mr. Gurdeep Singh / Addl. Engineer (PPX-BOI) 4th Floor, Main Administrative Building HEEP, BHEL Hardwar- 249403 Uttarakhand, India Email ID: singhg@bhel.in Tel: +91 1334 28 4175</p>	<p>Ms. Sonal Rautela / Dy. Manager (PPX-BOI) 4th Floor, Main Administrative Building HEEP, BHEL Hardwar- 249403 Uttarakhand, India Email ID: sonalr@bhel.in Tel: +91 1334 28 1786</p>
---	--

- 5.4 As per directives of CENTRAL VIGILANCE COMMISSION, GOVERNMENT OF INDIA, one agent cannot represent two or more suppliers or quote on their behalf in a particular tender. If so found at any stage, BHEL Hardwar is likely to cancel Enquiries / POs to such suppliers. Further, such Indian Agent is likely to be de-listed (Black listed for business from BHEL).
- 5.5 Vendors operating from BHEL quarters, unauthorized colonies on BHEL Land and Dharamshalas/ Hotels shall not be considered, hence such vendors need not apply.



PPX-BOI DEPARTMENT
BHARAT HEAVY ELECTRICALS LIMITED
HEEP: HARDWAR-249 403 (UTTRAKHAND)
TEL: +91 1334 28 4175 / 1786

Enquiry No.: B/4011/2022/0959/V1
Item: VARIABLE LOAD SPRING CAGES
Project: BUDGE-BUDGE
Enquiry Issue Date: 05/08/2022
Enquiry Due Date: 27/08/2022 (by 1345 HRS IST)

6 DEALING WITH BANNED SUPPLIERS/ CONTRACTORS IN BHEL

Offers of the bidders, who are on the banned list, as also the offers of the bidders who engage the services of the banned firms, shall be rejected. The list of banned firms is available on BHEL website hwr.bhel.com.

7 PRE-BID MEETING:

Pre-Bid clarifications & deviations (if any) should be sought within 10 days of issue of the enquiry. Bidders to compile all clarifications, if any, preferably in single communication. The clarifications would be provided within 3 days of receipt of queries. Bidders may also have across the table discussions for seeking pre-bid clarifications (if required).

8 IMPORTANT NOTE

NIT: MATERIAL DETAILS AND INSTRUCTION TO BIDDERS are to be read along with SPECIAL TERMS & CONDITIONS OF ENQUIRY and GISTC (as applicable for Foreign or Indian Bidders). A signed & stamped copy of these documents as a token of acceptance is to be submitted along with the offer. In the event of contradiction of terms and conditions mentioned, the order of preference shall be NIT: MATERIAL DETAILS AND INSTRUCTION TO BIDDERS followed by SPECIAL TERMS & CONDITIONS OF ENQUIRY followed by GISTC (General Instructions and Standard Terms & Conditions against Tender Enquiry).

Kindly ensure the timely submission of your offer (by 13:45 Hrs IST on the due date) and note that Late Offers shall not be entertained under any circumstances.

9 LIST OF ENCLOSURES:

- i. NIT: Material Details and Instruction to Bidders - No. of Pages: 03
- ii. Pre-Qualification Requirement (**Annexure-I**) - No. of Pages: 02
- iii. Technical Specification & Documents (**Annexure-II**) - No. of Pages: 12
- iv. Special Terms & Conditions for tender enquiry (**Annexure-III**) - No. of Pages: 04
- v. GISTC (For Indigenous Bidders) - No. of Pages: 13
- vi. GISTC (for Foreign Bidders) - No. of Pages: 13
- vii. BOQ (Price Format in Excel)
- viii. Standard Quality Plan.

For and on behalf of BHEL, Hardwar

Dy. Manager (PPX-BOI)

Pre-Qualification Requirement for Variable Load Spring Cages

Pre-Qualification Requirement for Variable Load Spring Cages

Document No. TLG/PQR/BI022, Date 09.10.2021

Description:-

The items covered under this category are intended for hangers and supports of turbine integral piping systems for all ratings of steam turbine, gas turbine and nuclear turbine sets. Variable load spring cages are used to accommodate vertical movement in piping system during operation of steam turbine.

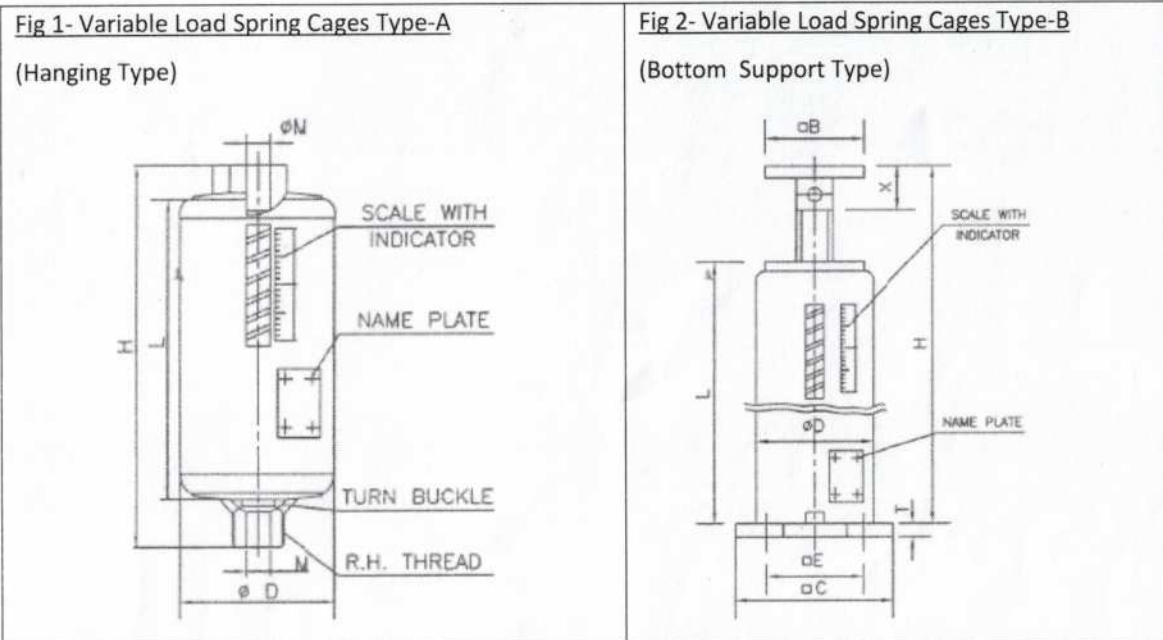

Qualification Criteria:-

Experience Requirement-

- Bidder to confirm that they are regular manufacturer/supplier of spring cages (refers to assembly of pre-set helical springs coil, ERW pipe cage, turn buckles, fasteners, scale and Plates etc.) satisfying all of the following criteria:-

Sl No	Product Features	Details
1.	Item Type	Variable Load Spring Cages Type A and Type B (refer above sketch) with blocking/locking facilities for Cold load.
2.	Application	Variable Load Spring Hangers and Supports for piping in Thermal Power Plant/Process Industries/Gas power plant/Nuclear power turbine.
3.	Load Range	4 Kg to 6000 Kg
4.	Travel Range	0-50mm, 0-100mm and 0-200mm

- Vendor should have supplied at least Fifty (50) nos of Variable Load Spring Cages including both type A & B in last Seven (7) years (from the date of issuance of enquiry) conforming technical details mentioned at point no. 1.

In support of point no. 1 & 2, vendor to furnish information, as per the following format for previous supplied spring cages as per relevant national/international standards or equivalent for the past seven (7) years from the date of issuance of enquiry.



Pre-Qualification Requirement for Variable Load Spring Cages

Sl No.	Project/Customer Name & Location	Contact Details of End-Customer (Address, Phone, Email etc.)	Purchase Order Reference No. and Issued Date	Type	Load, Travel and Spring rate	Material	Application	Qty (nos.)

Vendor to submit the following documents as an evidence of acceptance of supplied variable load spring cages for the above mentioned successfully executed order:-

- a) Copy of Un-Priced Purchase Orders executed.
- b) Customer approved / end user certified copy of General Arrangement drawing conforming to above technical details for any one of the submitted PO.
- c) Material Test certificate of springs, turnbuckle and other components, Load test/Spring rate test certificate etc. as per relevant indian/international standard for any one of the submitted PO. The submitted test certificates should have co-relation with PO.
- d) Acceptance certificate / despatch documents for any one of the submitted PO. The submitted PO should have correlation with PO.
- 3. Vendor shall submit the proof of manufacturer i.e. Factory license, NSIC certificate, Catalogue etc. clearly showing category as manufacturer of spring cages. In case the supplier is a non-manufacturer, valid authorization certificate from principal to be submitted.

Note:

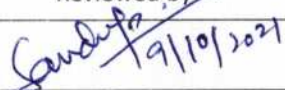
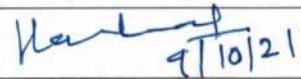

- 1. BHEL reserves the right to ask for more information / documents/ clarifications. Vendor's offer shall not be considered if vendor fails to furnish the document / information / clarifications as mentioned above or vendor doesn't meet the acceptance criteria as mentioned above.
- 2. In case of information / data furnished by the vendor found false/incorrect, BHEL reserves the right to reject their offer for the above item. Submission of fake/Fraudulent information shall be taken seriously.
- 3. BHEL team may visit Vendor works to assess vendor's manufacturing and testing facilities, if required.

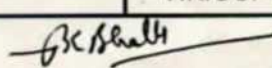
Prepared by	Reviewed by	Approved by
 09/10/2021	 19/10/2021	 21/10/21
Nilesch Kumar (Dy. Mgr./ TLG)	Sandeep Kumar Sonkar (Sr. Mgr./ TLG)	Shashank Kumar Gupta (AGM/ TLG & TCX)

दिनांक एवं हस्ताक्षर SIGN & DATE		उत्पाद मानक		ST 34004	
		STEAM TURBINE ENGINEERING PRODUCT STANDARD		पृष्ठ 09 का 01	Page 01 of 09
सुपरसेड्स INVENTORY NO	<u>SPECIFICATION FOR PROCUREMENT OF CONSTANT LOAD AND VARIABLE LOAD SPRING CAGES</u>			BASED ON BHEL OWN EXPERIENCE	
संश्लेषण संख्या अंश/संश्लेषण संख्या	<p>1.0 PRODUCT INFORMATION :</p> <p>The items covered under this document are intended for hangers and supports of TG Integral Piping to be installed in the machine hall of steam turbine sets .</p> <p>2.0 SCOPE OF WORK :</p> <p>The scope of work for the vendor shall be to supply completely (which includes design, selection of materials , fabrication, testing , packing and despatch) the spring cages covered by this document directly to thermal power station sites.</p> <p>3.0 BID DRAWINGS:</p> <p>Various types of spring cages sketches have been mentioned on sheet no.5,6,7, 8 , 9 along with BHEL code nos. and some mandatory dimensions. Vender has to furnish manufacturing drawings for BHEL approval against the requirement. Quantity of spring cages is to be supplied as per respective purchase order .</p> <p>4.0 MATERIAL SPECIFICATION :</p> <p>4.1 Material to be used for the manufacture of various parts of spring cages shall be strictly as per the sketches (mentioned above under clause no. 3) .</p> <p>5.0 WELDING REQUIREMENT:</p> <p>Welding of different components shall be carried out with matching electrodes by qualified welders and approved welding procedures as per ASME section-IX.</p> <p>6.0 FABRICATION:</p> <p>6.1 Dimensions of all the parts shall be in accordance with the drawing (mentioned above under clause 3) .</p> <p>6.2 Surface finish of various components is to be decided by the vendor and should be mentioned in the manufacturing drawings</p>				
सुपरसेड्स संख्या INVENTORY NO	<p>COPYRIGHT AND CONFIDENTIAL. The information on this documents is the property of Bharat Heavy Electrical Limited. It must not be used directly or indirectly in any way detrimental to the interest of the company.</p>				
सुपरसेड्स संख्या INVENTORY NO	<p>स्वत्वाधिकार एवं गोपनीय इस दस्तावेज में दी गई सूचना भारत भारती इंजीनियरिंग लिमिटेड की संपत्ति है। इस दस्तावेज को बिना अनुमति के किसी भी तरह प्रसारित, प्रकट, प्रतिलिपि बनाना, प्रसारित करना या किसी भी रूप में इस दस्तावेज के उपयोग करना गैर-कानूनी है।</p>				
दिनांक एवं हस्ताक्षर SIGN & DATE	21/9/04				
सहमत विभाग AGREED DEPTT.	नाम NAME	दिनांक एवं हस्ताक्षर DATE & SIGNATURE	अनुवादक TRANSLATED BY	नाम NAME	दिनांक एवं हस्ताक्षर SIGNATURE & DATE
QAX	S.S. CHAUHAN	18.9.04		N.K.KAUSHIK	18.9.04
TSX	KISHAN LAL	18.9.04		S.GOEL	18.9.04
			निरीक्षणकर्ता SUPERVISED BY	V.K.GUPTA	18.9.04
WORKED BY	SHRI PAL	18.9.04	स्वीकृति	 APPROVED : (B.K. BHALLA) AGM (STE)	
CHECKED BY	NILESH KUMAR	26/03/2022			
REV.NO. 08			निर्माण	जारी	दिनांक
DI. 26-03.22 STE-22-26			PREPARED : STE	ISSUED : STE (TL)	DATE : 06-10-87

दिनांक व प्रमाण SIGN & DATE		उत्पाद मानक PRODUCT STANDARD STEAM TURBINE ENGINEERING	ST 34004 पृष्ठ 09 का 02 Page 02 of 09
सुपरसेडस INVENTORY	<p>7.0 FINAL TESTING AND INSPECTION :</p> <p>All items covered by this document shall be subjected to inspection by the purchaser and vendor shall provide all possible help in this regard to the purchaser at no additional cost . Vendor shall advice purchaser 4 weeks in advance when items are ready for inspection . Approval or passing of test / inspection and thereby issue of the test certificates or waiver of inspection by purchaser shall not relieve the vendor of his responsibilities and obligations under the contract as well as shall not bind the purchaser to accept the equipment should it, on further tests after erection be found not complying with the contract .</p> <p>Following tests / checks shall be carried out on springs .</p> <p>7.1 Static load testing as per IS: 7906 , part – II . 7.2 Test load for compression to block length testing as per IS: 7906 , part-II . Following tests / checks shall be carried out after assembly . 7.3 Dimensional checking . 7.4 Spring rate checking as per IS 7906 , part -II . 7.5 Forged components shall be subjected to the following tests.</p> <p>(a) NDT :</p> <p>20 % or minimum two pieces whichever is more of each type of forged components shall be subjected to MPI/DPT for surface crack examinations . In case any defect is found the whole lot shall be examined . No linear indication is permitted .</p> <p>(b) Proof load :</p> <p>20 % or minimum two pieces whichever is more shall be subjected to two times of maximum permissible axial working load as mentioned in the component drawings . In case any defect is noticed after proof load test the whole lot shall be tested for proof load test .</p>		
COPYRIGHT AND CONFIDENTIAL The information on this documents is the property of Bharat Heavy Electricals Limited. It must not be used directly or indirectly in any way detrimental to the interest of the company	<p>8.0 TEST CERTIFICATES : Following inspection and tests certificates shall be submitted :</p> <p>8.1 For plates and turnbuckles (I) Chemical analysis. (II) Mechanical properties.</p> <p>8.2 For springs (I) Chemical analysis. (II) For clause 7.1 (III) For clause 7.2</p> <p>8.3 For Forged Components (I) Against Clause 7.5</p>		
स्वत्वाधिकार एवं गोपनीय इस प्रलेख में दी गई सूचना भारत की भारती-विद्युत की संपत्ति है जिसका प्रयोग एवं प्रसारण के बिना अनुमति के बिना नहीं किया जा सकता है।	दिनांक व प्रमाण SIGN & DATE 21/9/04	REV. NO. 08	
समीचीनी प्रती संख्या P-5670	निर्माणकर्ता WORKED BY N.K.K.	जांचकर्ता CHECKED BY S. G	18-09-04 18-9-04

दिनांक एवं हस्ताक्षर SIGN & DATE		उत्पाद मानक PRODUCT STANDARD STEAM TURBINE ENGINEERING	ST 34004 पृष्ठ 09 क। 03 Page 03 of 09																				
सामग्री सूची संख्या को अधिकारिता अर्पण हेतु	SUPERSEDES INVENTORY	8.4 For Assembly : (i) Against clause 7.3 (ii) Against clause 7.4 (iii) Pre-set load certificate. 9.0 GUARANTEE : Vendor shall guarantee all material , fabrication and workmanship of the spring cages furnished by him for a period of 24 months from the actual delivery or 18 months from the date of commissioning whichever is earlier . 10.0 MARKING AND IDENTIFICATION : Following informations should be marked on the name plate for proper identification of the spring cages . 10.1 BHEL Code NO . and DU NO . 10.2 Maximum travel . 10.3 Minimum / Maximum load . 10.4 Pre-set load , if any . 10.5 Spring rate . 11.0 PACKING , PAINTING AND PRESERVATION : 11.1 Water proof paper and felt lining of the package shall be overlapped at seams at least 15 mm and the seam shall be sealed . 11.2 All the parts except springs shall be carefully packed and painted with red oxide paint in line with painting scheme given below for transportation in such a manner that these are protected against damage and the climatic conditions to which it may be subjected in transit and storing up to 24 months . The threaded portion and machined surfaces shall be protected with grease. Spring surface shall be manganese phosphated and oil dipped . Painting Scheme <table border="1" style="width: 100%; border-collapse: collapse;"> <thead> <tr> <th style="text-align: left;">Paint (Coat)</th> <th style="text-align: left;">Paint Type</th> <th style="text-align: left;">No. of coat</th> <th style="text-align: left;">DFT*</th> </tr> </thead> <tbody> <tr> <td>Primer Paint</td> <td>: Epoxy base Zinc rich primer paint</td> <td>2 Coats</td> <td>70</td> </tr> <tr> <td>Intermediate Paint</td> <td>: Epoxy TiO₂ Pigmented Polyamide Cured Paint</td> <td>1 Coat</td> <td>70</td> </tr> <tr> <td>Finish (Final) Paint</td> <td>: Aliphatic Acrylic 2 Pack Polyurethane Finish paint</td> <td>2 Coats</td> <td>60</td> </tr> <tr> <td colspan="2" style="text-align: center;">Total DFT</td> <td>180</td> <td></td> </tr> </tbody> </table> <p style="text-align: center;">DFT – Dry Film Thickness (final) in microns.</p> <p>Shade : Smoke Grey ISC 692 as per IS-5 or Equivalent</p>		Paint (Coat)	Paint Type	No. of coat	DFT*	Primer Paint	: Epoxy base Zinc rich primer paint	2 Coats	70	Intermediate Paint	: Epoxy TiO ₂ Pigmented Polyamide Cured Paint	1 Coat	70	Finish (Final) Paint	: Aliphatic Acrylic 2 Pack Polyurethane Finish paint	2 Coats	60	Total DFT		180	
Paint (Coat)	Paint Type	No. of coat	DFT*																				
Primer Paint	: Epoxy base Zinc rich primer paint	2 Coats	70																				
Intermediate Paint	: Epoxy TiO ₂ Pigmented Polyamide Cured Paint	1 Coat	70																				
Finish (Final) Paint	: Aliphatic Acrylic 2 Pack Polyurethane Finish paint	2 Coats	60																				
Total DFT		180																					
COPYRIGHT AND CONFIDENTIAL. The information on this documents is the property of Bharat Heavy Electrical Limited It must not be used directly or indirectly in any way detrimental to the interest of the company	स्वत्वाधिकार एवं गोपनीय इस दस्तावेज में दी गई सूचना भारत भारती इलेक्ट्रिकल्स की सम्पत्ति है इसका प्रसार एवं प्रयोग के बिना कहीं भी नहीं किया जाये, जो कि कंपनी के हित में सम्मानजनक हो न कि हानिकारक।																						
		दिनांक एवं हस्ताक्षर SIGN & DATE 21/9/10	REV. NO. 08	निर्माणकर्ता WORKED BY N.K.K.	18-09-04																		
सामग्री सूची संख्या INVENTORY NO. P-5670		जांचकर्ता CHECKED BY S.Goel	18-09-04																				

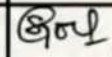
दिनांक एवं हस्ताक्षर SIGN & DATE		उत्पाद मानक PRODUCT STANDARD STEAM TURBINE ENGINEERING	ST 34004	
SUPERSEDES INVENTORY	संपूर्ण सूची संख्या को अधीनस्थ संख्या में		पृष्ठ 09 क 04 Page 04 of 09	
<p>The surface shall be cleaned before painting with suitable means . However in case of any specific requirement from the customer same shall be informed separately .</p> <p>12.0 INSTRUCTION FOR BID PREPARATION :</p> <p>Vendor shall essentially furnish unit rates for each type of spring cage and manufacturing drawing , failure to furnish the same the bid may be rejected .</p> <p>13.0 CROSS REFERED STANDARDS :</p> <p>ASME SEC-IX, IS:2004, IS:2062, IS:4454 PART-I, IS:7906 PART-II , IS : 54 85 : 3 6 0 2</p>				
<p>COPYRIGHT AND CONFIDENTIAL</p> <p>The information on this documents is the property of Bharat Heavy Electrical Limited. It must not be used directly or indirectly, in any way detrimental to the interest of the company.</p> <p>स्वत्वाधिकार एवं गोपनीय</p> <p>इस दस्तावेज में दी गई सूचना अथवा इसकी प्रतिलिपि/अन्य की प्रतिलिपि के द्वारा अथवा इस प्रतिलिपि/अन्य का उपयोग करके किसी भी प्रकार का नुकसान होना नहीं चाहिए।</p>				
संपूर्ण सूची संख्या INVENTORY NO. P-5670	दिनांक 5/11/18	REV. NO. 08	निर्माणकर्ता WORKED BY N.K.K	 18.09.04
			जांचकर्ता CHECKED BY S.Goel	 18-09-04

हस्ताक्षर और दिनांक SIGN & DATE		उत्पाद मानक PRODUCT STANDARD STEAM TURBINE ENGINEERING	ST 34004 पृष्ठ 09 का 05 PAGE 05 OF 09
------------------------------------	---	--	---

सामग्री सूची संख्या को INVENTORY NO. P-5670	सामग्री सूची संख्या को SUPERSEDES REV. NO. 08	हस्ताक्षर और दिनांक SIGN & DATE Sandeep 18/4/22	हस्ताक्षर और दिनांक SIGN & DATE	COPYRIGHT AND CONFIDENTIAL THE INFORMATION ON THIS DOCUMENT IS THE PROPERTY OF BHARAT HEAVY ELECTRICALS LIMITED. IT MUST NOT BE USED DIRECTLY OR INDIRECTLY IN ANY WAY DETERIMENTAL TO THE INTEREST OF THE COMPANY.
--	---	--	------------------------------------	--

TABLE : VARIABLE LOAD SPRING CAGE (TYPE-A)

MAXIMUM TRAVEL IN mm	MIN/LOAD/ MAX/LOAD IN Kg.		BHEL CODE NO.	L	H	M	φ D	APPROX. WEIGHT IN Kg.	SPRING RATE IN Kg./mm
	12/52	41/125							
50	12/52	41/125	W97372424437	245	280	M 10	90	03.0	00.83
	83/250	166/500	W97372424453	150	185	M 12	115	3.8	03.33
	333/1000	666/2000	W97372424283	155	200	M 16	115	05.0	06.66
	1333/4000	04/25	W97372424330	180	230	M 20	155	10.0	13.33
			W97372424461	215	275	M 24	180	16.5	26.66
100	12/52	41/125	W97372424470	245	315	M 30	220	31.0	53.33
	83/250	166/500	W97372424550	205	235	M 10	80	1.9	00.21
	333/1000	666/2000	W97372424143	245	280	M 12	90	03.0	00.40
	1333/4000	04/25	W97372424089	250	290	M 16	115	06.0	01.66
			W97372424020	290	300	M 20	155	06.5	03.33
200	12/52	41/125	W97372424321	305	370	M 24	180	21.0	13.33
	83/250	166/500	W97372424688	360	430	M 30	220	40.0	26.66
	333/1000	666/2000	W97372424070	480	370	M 42	245	80.0	53.33
	1333/4000	04/25	W97372424239	470	510	M 12	90	05.0	00.21
			W97372424224	475	510	M 16	115	06.0	00.41

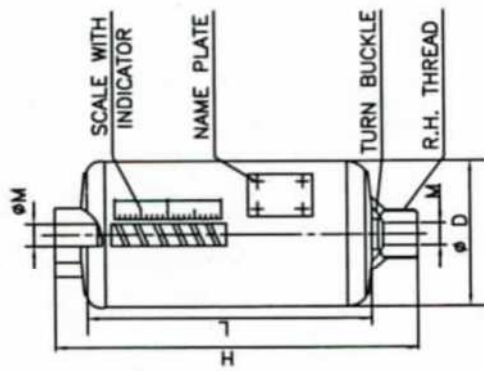

NOTES :-

- (1) THE SKETCH INDICATES ONLY GENERAL OUTLINE DIMENSION FOR GENERAL INFORMATION. VENDOR HAS TO FURNISH MANUFACTURING DRAWINGS ETC. FOR REVIEW.
- (2) PROVISION SHOULD BE MADE TO LOCK THE HANGER IN ANY POSITION BEFORE ERECTION AND DURING HYDRAULIC TESTING AND THIS LOCKING ARRANGEMENT SHOULD BE CAPABLE TO WITHSTAND 1.5 TIMES THE MAXIMUM LOAD.
- (3) MATERIAL OF SPRING SHOULD BE Gr-III, IS:4454 (PART-1) AND FOR TURNBUCKLE CLASS-II, IS:2004.
- (4) MATERIAL FOR THE REST COMPONENTS SHOULD BE Gr-27, BS:3602 OR Gr-B, IS:2062 OR EQUIVALENT.
- (5) MINIMUM VARIATION IN SPRING RATE = ±10 %.
- (6) DIMENSION "H" IS CORRESPONDING TO ZERO COMPRESSION OF THE SPRING. THIS DIMENSION SHALL BE EXTENDED ACCORDING TO THE LOAD ON THE SPRING CAGE.
- (7) TURNBUCKLE SHOULD BE OF SUCH DESIGN THAT DIMENSION "H" CAN BE ADJUSTED BY 100 MM BY USING TURNBUCKLE.
- (8) DIMENSION M, MIN./ MAX. LOAD AND SPRING RATE ARE MANDATORY.

नाम/NAME SHRI PAL	हस्ताक्षर/SIGN <i>Shri Pal</i>	दिनांक/DATE 26.03.2022
CHECKED BY NILESH KUMAR	हस्ताक्षर/SIGN <i>Nilesh Kumar</i>	दिनांक/DATE 26.03.2022

स्वत्वाधिकार एवं गोपनीयता
 This information on this documents is the property of Bharat Heavy Electrical Limited It must not be used directly or indirectly in any way detrimental to the interest of the company

उत्पाद मानक
PRODUCT STANDARD
STEAM TURBINE ENGINEERING

ST 34004
 पृष्ठ 09 का 07
 Page 07 of 09

स्वत्वाधिकार एवं गोपनीयता
 This information on this documents is the property of Bharat Heavy Electrical Limited It must not be used directly or indirectly in any way detrimental to the interest of the company

उत्पाद मानक
PRODUCT STANDARD
STEAM TURBINE ENGINEERING



उत्पाद मानक
PRODUCT STANDARD
STEAM TURBINE ENGINEERING

ST 34004
 पृष्ठ 09 का 07
 Page 07 of 09

स्वत्वाधिकार एवं गोपनीयता
 This information on this documents is the property of Bharat Heavy Electrical Limited It must not be used directly or indirectly in any way detrimental to the interest of the company

उत्पाद मानक
PRODUCT STANDARD
STEAM TURBINE ENGINEERING

उत्पाद मानक
PRODUCT STANDARD
STEAM TURBINE ENGINEERING

ST 34004
 पृष्ठ 09 का 07
 Page 07 of 09

स्वत्वाधिकार एवं गोपनीयता
 This information on this documents is the property of Bharat Heavy Electrical Limited It must not be used directly or indirectly in any way detrimental to the interest of the company

उत्पाद मानक
PRODUCT STANDARD
STEAM TURBINE ENGINEERING

स्वत्वाधिकार एवं गोपनीयता
 This information on this documents is the property of Bharat Heavy Electrical Limited It must not be used directly or indirectly in any way detrimental to the interest of the company

TABLE : VARIABLE LOAD SPRING CAGE (TYPE-C)

MAXIMUM TRAVEL IN mm	MIN. LOAD / MAX. LOAD IN Kg.	BHEL CODE NO.	Ø D	L	H	Ø F	M	APPROX. WEIGHT IN Kg.	SPRING RATE IN Kg./mm
100	12/52	W97372424151	90	250	360	14	M 12	3.0	0.40
	41/125	W97372424127							0.83
	83/250	W97372424119	115	290	400	18	M 16	1.66	
	166/500	W97372424097						3.33	
333/1000	W97372424232	155	290	400	22	M 20	12.0	6.66	

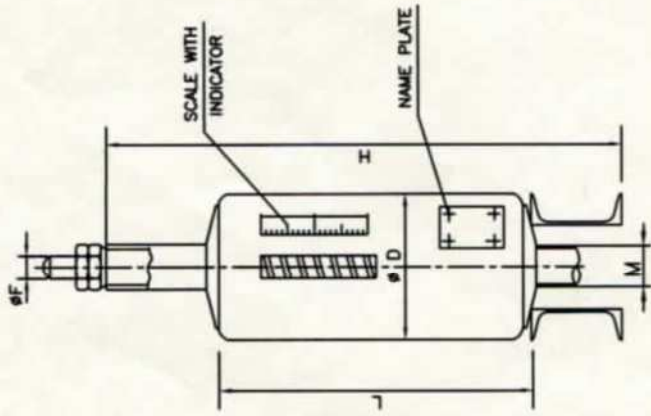

NOTES :-

- (1) THE SKETCH INDICATES ONLY GENERAL OUTLINE DIMENSION FOR GENERAL INFORMATION. VENDOR HAS TO FURNISH MANUFACTURING DRAWINGS ETC. FOR REVIEW .
- (2) PROVISION SHOULD BE MADE TO LOCK THE HANGER IN ANY POSITION BEFORE ERECTION AND DURING HYDRAULIC TESTING AND THIS LOCKING ARRANGEMENT SHOULD BE CAPABLE TO WITHSTAND 1.5 TIMES THE MAXIMUM LOAD .
- (3) MATERIAL OF SPRING SHOULD BE Gr- III , IS:4454 (PART-1) AND FOR TURNBUCKLE CLASS-II , IS:2004 .
- (4) MATERIAL FOR THE REST COMPONENTS SHOULD BE Gr-27, BS:3602 OR Gr-B, IS:2062 OR EQUIVALENT .
- (5) MAXIMUM VARIATION IN SPRING RATE $\pm 10\%$.
- (6) DIMENSION "H*" IS CORRESPONDING TO ZERO COMPRESSION OF THE SPRING. THIS DIMENSION SHALL BE RECUDED ACCORDING TO THE LOAD ON THE SPRING CAGE.
- (7) DIMENSION F, M, MIN/MAX. LOAD & SPRING RATE ARE MANDATORY.

INVENTORY NO.
 P-5670

REV. NO.
 00

निर्माणकर्ता
 WORKED BY
 N.K.K

जांचकर्ता
 CHECKED BY
 S..G.

18-09-04
 18-09-04

उत्पाद मानक

ST 34004



PRODUCT STANDARD
STEAM TURBINE ENGINEERING

पृष्ठ 09 का 09

Page 09 of 09

दिनांक एवं हस्ताक्षर
SIGN & DATESUPERSEDES
INVENTORYसंशोधन एवं
संशोधन संख्या

COPYRIGHT AND CONFIDENTIAL
The information on this document is the property of Bharat Heavy Electrical Limited. It must not be used directly or indirectly in any way detrimental to the interest of the company.

स्वत्वाधिकार एवं गोपनीय

इस दस्तावेज़ में दी गई सूचना भारत भारती इंजीनियरिंग लिमिटेड की संपत्ति है। इसका प्रयोग एवं प्रसारण बिना लिखित अनुमति के बिना नहीं किया जा सकता।

दिनांक एवं हस्ताक्षर
SIGN & DATEसंशोधन एवं
INVENTORY NO.

CONSTANT LOAD SPRING CAGE (TYPE-E)

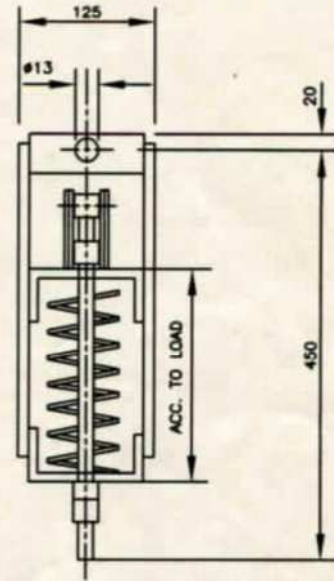
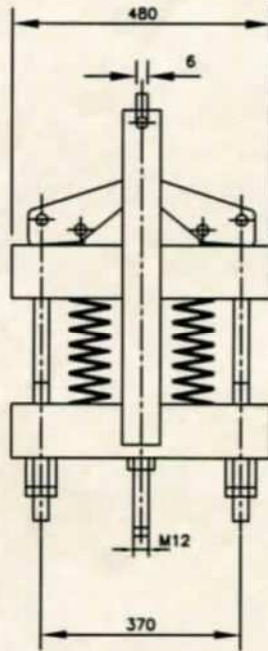

TABLE

LOAD IN Kg.	BHEL CODE NO.	APPROX. WEIGHT IN Kg.
25	W97372442044	20.00
27	W97372442060	20.00
33	W97372442079	20.00
36	W97372442087	20.00
23	W97372442095	20.00
20	W97372442109	20.00
22	W97372442117	20.00
15	W97372442125	20.00
16	W97372442133	20.00
15.5	W97372442141	20.00
10	W97372442150	20.00

NOTES :-

- (1) THE SKETCH INDICATES ONLY GENERAL OUTLINE DIMENSION FOR GENERAL INFORMATION. VENDOR HAS TO FURNISH MANUFACTURING DRAWINGS ETC. FOR REVIEW.
- (2) PROVISION SHOULD BE MADE TO LOCK THE HANGER IN ANY POSITION BEFORE ERECTION AND DURING HYDRAULIC TESTING AND THIS LOCKING ARRANGEMENT SHOULD BE CAPABLE TO WITHSTAND 1.5 TIMES THE MAXIMUM LOAD.
- (3) MATERIAL OF SPRING SHOULD BE Gr- III, IS:4454 (PART-1) AND FOR TURNBUCKLE CLASS-II, IS:2004.
- (4) MATERIAL FOR THE REST COMPONENTS SHOULD BE Gr-27, BS:3602 OR Gr-B, IS:2062 OR EQUIVALENT.
- (5) MAXIMUM VARIATION IN SPRING RATE $\pm 10\%$.
- (6) MAXIMUM VERTICAL MOVEMENT IS 100 mm.

REV. NO.

09

निर्माणकर्ता
WORKED BY

N.K.K

जांचकर्ता
CHECKED BY

S..G.

18-09-04

18-09-04

BHARAT HEAVY ELECTRICALS LIMITED, HARDWAR

STEAM TURBINE ENGINEERING

DATE: 02.05.22 PAGE NO. 1

BILL OF MATERIAL OF HANGER & SUPPORTS FOR TURBINE INTEGRAL PIPING

CUSTOMER / PROJECT: CESC/Budge Budge, West Bengal UNIT RATING: 250-MW DOCUMENT NO.: 313177A2550

SYSTEM DESCRIPTION: VARIABLE LOAD SPRING CAGES (SPARE) REVISION NO.: 00

RV. NO.	ITEM NO.	DU. NO.	DESCRIPTION OF SUB ASSEMBLY/ITEM	DRAWING NO.	REV.	MATERIAL SPECIFICATION	QTY	UNIT WT.	REMARKS
	001.00	9471	SPRING CAGE TYPE-A PCL 0216 KG	ST-34004	C	W97372424020	1	.000	
	002.00	9425	SPRING CAGE TYPE-A PCL 0225 KG	ST-34004	C	W97372424011	2	.000	
	003.00	9422	SPRING CAGE TYPE-A PCL 0200 KG	ST-34004	C	W97372424011	2	.000	
	004.00	9473	SPRING CAGE TYPE-A PCL 0250 KG	ST-34004	C	W97372424020	2	.000	
	005.00	9496	SPRING CAGE TYPE-A PCL 0300 KG	ST-34004	C	W97372424313	1	.000	
	006.00	9420	SPRING CAGE TYPE-A PCL 0183 KG	ST-34004	C	W97372424011	1	.000	
	007.00	9600	SPRING CAGE TYPE-A PCL 1466 KG	ST-34004	C	W97372424291	1	.000	
	008.00	9537	SPRING CAGE TYPE-A PCL 0633 KG	ST-34004	C	W97372424038	1	.000	
	009.00	9532	SPRING CAGE TYPE-A PCL 0466 KG	ST-34004	C	W97372424038	1	.000	
	010.00	9484	SPRING CAGE TYPE-A PCL 0433 KG	ST-34004	C	W97372424020	2	.000	
	011.00	9534	SPRING CAGE TYPE-A PCL 0533 KG	ST-34004	C	W97372424038	1	.000	
	012.00	9898	SPRING CAGE TYPE-C PCL 0166 KG	ST-34004	C	W97372424119	2	.000	
	013.00	9473	SPRING CAGE TYPE-A PCL 0250 KG	ST-34004	C	W97372424020	1	.000	
	014.00	9771	SPRING CAGE TYPE-B PCL 0433 KG	ST-34004	C	W97372424062	1	.000	
	015.00	9476	SPRING CAGE TYPE-A PCL 0300 KG	ST-34004	C	W97372424020	1	.000	
	016.00	9896	SPRING CAGE TYPE-C PCL 0150 KG	ST-34004	C	W97372424119	2	.000	
	017.00	9780	SPRING CAGE TYPE-B PCL 0733 KG	ST-34004	C	W97372424062	1	.000	
	018.00	9761	SPRING CAGE TYPE-B PCL 0383 KG	ST-34004	C	W97372424054	1	.000	
	019.00	9777	SPRING CAGE TYPE-B PCL 0633 KG	ST-34004	C	W97372424062	1	.000	

CONTINUED ON PAGE NO. : 2

BHARAT HEAVY ELECTRICALS LIMITED, HARDWAR

STEAM TURBINE ENGINEERING

DATE: 02.05.22 PAGE NO. 2

BILL OF MATERIAL OF HANGER & SUPPORTS FOR TURBINE INTEGRAL PIPING

CUSTOMER / PROJECT: CESC/Budge Budge, West Bengal UNIT RATING: 250-MW DOCUMENT NO.: 313177A2500
SYSTEM DESCRIPTION: VARIABLE LOAD SPRING CAGES (SPARE) REVISION NO.: 00

RV. NO.	ITEM NO.	DU. NO.	DESCRIPTION OF SUB ASSEMBLY/ITEM	DRAWING NO.	REV.	MATERIAL SPECIFICATION	QTY	UNIT	REMARKS
	020.00	9773	SPRING CAGE TYPE-B PCL 0500 KG	ST-34004	C	W97372424062	1	.000	
	021.00	9735	SPRING CAGE TYPE-B PCL 0141 KG	ST-34004	C	W97372424046	1	.000	
	022.00	9701	SPRING CAGE TYPE-B PCL 0095 KG	ST-34004	C	W97372424216	1	.000	

ISSUED BY: SHRI PAL

APPROVED BY: NILESH

NOTES

1. DU. NOS ARE TO BE ENGRAVED OR TAGGED ON EACH ITEM AS PER HW0400397 FOR IDENTIFICATION.

भारत हेवी इलेक्ट्रिकल्स लिमिटेड

एस. टी. ई.- टरबाइन लेआउट अभियांत्रिकी)

पुरानी अभियांत्रिकी भवन, रानीपुर, हरिद्वार - 249 403; दूरभाष : 01334 - 281512;

Bharat Heavy Electricals Limited

S.T.E. - Turbine Layout (Engineering)

Old Engineering Building, Ranipur, Haridwar - 249 403; Phone: 01334 - 281512;



विषय : **CESC LTD. / Budge-Budge 210MW PROJECT**
सी०ई०एस०सी० लिमिटेड / बज-बज 210 मेगा वाट परियोजना

APPLICATION : S.T.E. - Turbine Layout (Engineering)

PRODUCT: STEAM TURBINE

DOCUMENT NO. : 413177A2501

ITEM DESCRIPTION : VARIABLE LOAD SPRING CAGES

REVISION NO. : 00

UNIT RATING : 210 MW

Painting Scheme			
Paint (Coat)	Paint (Type)	No of Coat	DFT
Primer Paint	Epoxy base Zinc rich primer paint	2 Coat	70
Intermediate Paint	Epoxy Resin Pigmented with MIO & TiO ₂ and Polyamide as an accelerator or hardener for cold curing.	1 Coat	70
Finish (Final) Paint	Aliphatic Acrylic 2 Pack Polyurethane Finish Paint	2 Coat	60
DFT - Dry Film Thickness (final) in microns.		TOTAL DFT	200

Shade: Smoke Grey ISC 692 as per IS-5 or Equivalent.

निलेश कुमार
(निलेश कुमार)
उपरो प्रबंधक (टी.एल.)

SPECIAL TERMS & CONDITIONS OF TENDER ENQUIRY

Special Terms and conditions of tender enquiry (In addition to General Instructions and Standard terms & conditions (GISTC) as enclosed):

Sl. No.	Terms	Description	Bidder's confirmation
1.	Confirmation to General Instructions and standard terms & conditions	<p>Please confirm each clause of following documents:</p> <ol style="list-style-type: none"> 1. General Instructions and standard terms & conditions for bidding against tender enquiry (GISTC, Rev. 06). 2. Special terms & conditions of tender (Annexure-III). <p>Deviation to conditions mentioned in above documents, if any, shall be submitted along with offer in separate documents. Please note that in case, no deviation is received along with the offer, it will be considered that all terms and conditions mentioned in above documents are acceptable to the bidder and your offer will be processed accordingly.</p>	
2.	Special Instruction	<p>Please note that as per BHEL's Policy, we cannot allow Price impact for the requirement / scope of supply, which is a part of specifications of our tender enquiry. Hence please read all specification / documents thoroughly and submit your offer as per specifications of tender enquiry.</p> <p>In case of any confusion / un-clarity on any of the clause / requirement of specification, please clarify the same from BHEL before submission of offer.</p>	
3.	Evaluation criteria	<p>Evaluation of tender shall be done on Total Landed Cost to BHEL upto Project site basis.</p> <p>Please note that Exchange rate for evaluation of offer of Foreign bidders would be taken as TT Selling rate of SBI as on schedule date of tender opening (Part-1 bid i.e. techno-commercial offer).</p>	
4.	Validity	<p>Confirm that validity of the offer shall be 120 days from the due date of opening of Techno-Commercial Offers.</p> <p>BHEL reserves the right to reject any or all quotations, quoting validity less than 120 days.</p>	
5.	Basis of quotation	<p>Indigenous bidder: Prices are to be quoted strictly as per BOQ (Price Format in excel) enclosed with this tender enquiry. Prices have to be quoted on FOR basis upto destination i.e. Ex-works Freight prepaid upto Budge-Budge project site basis as per Price format. <i>Kindly confirm.</i> The goods can be dispatched through any BHEL approved transporters having their branch at Haridwar. The names and addresses of transporters approved by IBA as well as BHEL are posted at our website www.hwr.bhel.com.</p> <p>Foreign bidder: Prices are to be quoted on CFR Mumbai (Nhava Sheva port) basis, strictly as per BOQ (Price Format in excel) enclosed with this tender enquiry. Transportation from Port of Origin to Mumbai Port will be to your account. Please also inform the Port of Loading (FOB).</p> <p>Consignee Address will be as under: BUDGE-BUDGE GENERATING STATION STORES, PO-PUJALI, BUDGE-BUDGE 24 PGNS(S) BUDGE-BUDGE - 700 138, WEST BENGAL</p> <p>Transit insurance would be arranged by BHEL. Please send your offer keeping this in view.</p>	
6.	Firm & Fixed Prices	<p>Confirm that prices will remain firm and fixed during the entire validity and execution of the project.</p>	

7.	Delivery Period:	Material is required as per the delivery schedule mentioned in the NIT. However, bidder to quote their best minimum possible delivery in no. of weeks from the date of PO placement or drawings & documents approval/ manufacturing clearance from BHEL.	
		Final delivery would be either delivery period quoted by bidder in offer or enquiry delivery schedule as mentioned above or manufacturing clearance from BHEL, whichever is later.	
8.	Technical Requirement	Please quote your valuable offer as per BHEL specification and documents i.e. Technical Specification No. ST34004 (Rev. 08) , Document No. 313177A2550 (Rev. 0) & 413177A2501 (Rev. 0) enclosed with this tender enquiry.	
9.	Engineering Document approval	<p>Drawings/ Datasheet/ Documents as called for in BHEL specifications shall be submitted for approval to BHEL for BHEL/customer approval within 30 days of Purchase Order. BHEL will arrange the approval of the drawings/data sheets/ documents within 30 days of their receipt provided those are complete in all respect.</p> <p>The delay due to late submission shall be to supplier's account whereas delay in approval of documents shall be BHEL's account. In case of delay on account of BHEL, delivery shall be re-scheduled accordingly.</p>	
10.	Quality Requirement & Inspection	<p>Indigenous bidder:</p> <p>a) Kindly submit duly filled endorsed copy (sign & stamp) of BHEL Standard Quality Plan no. QA/BI/QP/011 Rev. 03 (copy enclosed) along with your offer for approval.</p> <p>b) Inspection shall be done by BHEL nominated third party inspection agency M/s INTERTEK as per above mentioned BHEL Quality Plan. Kindly confirm.</p> <p>The charges of TPI will be borne by BHEL. However, co-ordination with the Third Party Inspection Agencies would be the sole responsibility of the bidder. Inspection call shall be raised by vendor at least 07 days in advance of readiness of material.</p> <p>Foreign bidder:</p> <p>Kindly note that Testing & Certification is required as per ordering specification. Kindly confirm.</p>	
11.	LD for Late delivery	<p>Liquidated Damages (LD) for Late delivery w.r.t. contractual delivery shall be applicable at the rate of 0.5% per week or part thereof on the value of respective delayed supplies subject to a maximum of 10% of the value of respective delayed supplies. Value of delayed supplies will mean the Gross Value payable to the vendor (Before LD) against such supplies excluding taxes and duties.</p> <p><i>This should be read and complied in conjunction with clause 9 of LD for Late Delivery of GISTC, Rev. 06 enclosed with tender enquiry.</i></p>	
		Date of GR (Good Receipt)/ BL (Bill of Lading) would be treated as the date of delivery for penalty purposes.	
		<i>In case of any deviation to above penalty clause, BHEL reserves the right to load the offers to the extent to which it is not agreed by vendors (at offered value).</i>	
12.	MDCC clause	<p>Material shall be dispatched only after issue of Material dispatch clearance certificate (MDCC) by BHEL/Customer.</p> <p>All Test certificates (TCs) & Inspection Reports should be submitted by supplier to BHEL at least 07 days in advance for review and issuance of MDCC.</p> <p>Any delay on submission/approval shall be on respective account.</p> <p>Material should be dispatched within 07 days of issue of MDCC by BHEL.</p>	
13.	O&M Manuals	O&M manual of the item as mentioned in BHEL Specification shall be provided with dispatch of material. Kindly confirm.	

14.	Guarantee/ Warranty Clause:	Supplier shall guarantee the trouble free operation of the equipment for a period of 24 months from the date of dispatch or 18 months from the date of commissioning, whichever is earlier. In case of any failure or trouble reported from site, the supplier should depute their representative immediately to attend the problem and replace the defective component/part if required, without any additional cost to BHEL.	
15.	Payment Terms	<p>Payment terms shall be as per clause 10 of GISTC, Rev. 06. 'Receipt & Acceptance certificate' wherever mentioned in GISTC should be treated as 'Material Receipt certificate'.</p> <p><i>This should be read and complied in conjunction with clause 10 for Payment terms of GISTC, Rev. 06 enclosed with tender enquiry.</i></p> <p><u>Negotiable documents for payment are as under:</u></p> <p>Indigenous bidder:</p> <ul style="list-style-type: none"> • Material receipt certificate from BHEL. • Original Guarantee certificate. • Original Invoice • Original Packing list • Consignee Copy of GR • Original Inspection Reports issued by Inspection agency • Copy of MDCC issued by BHEL <p><u>Please ensure to send the Original GR (Consignor copy) alongwith above original negotiation documents to BHEL Haridwar for End customer billing purpose.</u></p> <p>Foreign bidder:</p> <ul style="list-style-type: none"> • 2 of 3 Original Bill of lading • Material receipt certificate from BHEL. • Original certificate of origin certified by Chamber of commerce of originating country. • Original Guarantee certificate. • Original Test certificates • Original Invoice • Original Packing list • Copy of MDCC issued by BHEL • Receipt & acceptance certificate of 01 of 03 OBL from BHEL Haridwar • Phytosanitary certificate (if applicable, refer GISTC) <p>Note: 1 of 3 Original Bill of lading shall be sent by supplier directly to: AGM-Incharge (PPX-BOI), Main Administrative Building Bharat Heavy Electricals Limited HEEP- HARIDWAR-249403, Uttarakhand, India.</p> <p><i>This should be read and complied in conjunction with clause 10 for Payment terms of GISTC, Rev. 06 enclosed with tender enquiry.</i></p> <p><u>Loading for deviation in Payment terms:</u></p> <p>In case of any deviation, BHEL will evaluate your offer after loading on account of deviation in payment terms as per extant rules/policy of BHEL Haridwar. For details please refer clause 10 of GISTC, Rev. 06 enclosed with tender enquiry.</p>	
16.	Risk Purchase Clause:	Kindly confirm that Risk Purchase shall be applicable as per clause 18 of GISTC (Rev. 06) enclosed with tender enquiry.	
17.	Force Majeure Clause:	Kindly confirm that Force Majeure shall be applicable as per clause 19 of GISTC (Rev. 06) enclosed with tender enquiry.	

Tender Enquiry No. B/4011/2022/0959/V1

18.	Arbitration Clause:	Kindly confirm that Arbitration shall be applicable as per clause 21 of GISTC (Rev. 06) enclosed with tender enquiry.	
19.	Order Acceptance:	Ink signed order acceptance shall be furnished within 15 days of order placement. In case, order acceptance does not receive within 15 days of order placement, PO deemed to be accepted by you.	
20.	Deviation: (if any)	Kindly confirm that there is no deviation with respect to BHEL Specifications. However, If there is any deviation with respect to the tender documents then the same should be brought out specifically in separate annexure marked Deviations (Technical/Commercial).	

Kindly ensure to submit the below Enclosures along with 'Techno-Commercial Bid':

1. Copy / Replica of Price Bid (without prices) as per BOQ/Price Format.
2. Signed & Stamped copy (each page) of duly filled Special terms & conditions of tender enquiry (Annexure-III).
3. Signed & Stamped copy (each page) of GISTC (Rev. 06) as token of acceptance.

(Signature of supplier with seal)



BHARAT HEAVY ELECTRICALS LIMITED

HEEP-HARIDWAR, UTTARAKHAND (249403)

General Instructions and Standard Terms & Conditions for bidding against Tender Enquiry (GISTC)

For Indian Bidders (Version June-2021, Rev: 06)

Table of Contents

1. GENERAL	1
2. ORIGIN OF QUOTATION	1
3. SUBMISSION OF TENDER	1
4. TENDER OPENING	2
5. SPECIFICATION, DRAWINGS & STANDARD	2
6. PRICE SCHEDULE	3
7. REVERSE AUCTION	3
8. DELIVERY TERMS	3
9. LD FOR LATE DELIVERY	4
10. PAYMENT TERMS	4
11. TAXES & DUTIES	5
12. BANK GUARANTEE	6
13. GUARANTEE / WARRANTY AND CORRESPONDING REPAIRS / REPLACEMENT OF GOODS	6
14. QUALITY REQUIREMENT	6
15. VALIDITY	6
16. RIGHT OF ACCEPTANCE	6
17. TRANSIT INSURANCE	7
18. RISK PURCHASE	7
19. FORCE MAJEURE CLAUSE	7
20. NON-DISCLOSURE AGREEMENT	8
21. SETTLEMENT OF DISPUTES / ARBITRATION	8
22. WHARFAGE / DEMURRAGE RESPONSIBILITY	8
23. CONDITIONS FOR AVAILING MICRO & SMALL ENTERPRISES (MSE'S) BENEFITS	8
24. INFORMATION TO THE BIDDERS	10
25. MAKE IN INDIA (GOVT-NOTIFICATION)	10
26. RESTRICTIONS UNDER RULE 144(XI) OF THE GENERAL FINANCIAL RULES (GFRs), 2017	12

27. NOTE..... 12

1. GENERAL.

These general terms & conditions shall apply to all the Tender Enquiries, notice inviting tenders, request for quotations concerning the supply of goods and / or rendering of services to Bharat Heavy Electricals Ltd., HEEP, Haridwar (hereinafter referred to as BHEL or the Purchaser). In case of placement of order these conditions will become part of Purchase Order (P.O) until unless the deviations are specifically agreed by BHEL.

2. ORIGIN OF QUOTATION.

- a) The quotation should preferably be from the principal bidder. However tender specific authorized registered dealer/agent can also submit the bid on their behalf, failing which the quotation is liable to be ignored. BHEL prefers to deal directly with the principal manufacturers.
- b) An agent cannot quote on behalf of more than one principal in the same Tender Enquiry.

3. SUBMISSION OF TENDER.

- a) Bid / Quotation must be enclosed in sealed cover on which tender enquiry number and the due date MUST BE written and be invariably sent under REGISTERED POST / SPEED POST / COURIER / Dropped in the Tender Box: addressed as follows:

Quotation against Enquiry No. _____

Dated: _____

Due on: _____

To,

**THE HEAD OF MATERIALS MANAGEMENT,
Heavy Electrical Equipment Plant,
Bharat Heavy Electricals Limited,
HARIDWAR-249403 (Uttarakhand), INDIA.**

- b) TENDER ROOM is located at: Room No. - 415, 4th Floor, Main Admin. Building, BHEL-HEEP, Haridwar.

Quotations / Bids not in accordance with General Instructions and Standard Terms & Conditions are likely to be ignored.



BHARAT HEAVY ELECTRICALS LIMITED

HEEP-HARIDWAR, UTTARAKHAND (249403)

General Instructions and Standard Terms & Conditions for bidding against Tender Enquiry (GISTC)

For Indian Bidders (Version June-2021, Rev: 06)

- c) In case of Three / Two Part Bid, technical bid containing technical offer, duly signed and un-priced copy of the Price Bid should be kept in one envelope. Price Bid containing only the price should be kept in a separate envelope. All envelopes indicating Part-1 or Part-2 or Part-3 as the case may be to be put in a bigger envelope. Please note that un-priced bid should be the exact replica of price bid but without prices.
- d) The bid / quotation must be posted before due date, keeping allowance for postal transit time. Quotations sent by any mode but not received in time will be ignored. Tender received through authorized E-mail is also acceptable. However, in time submission of tender in tender box shall be the responsibility of the bidder, sent through any mode. Documents submitted with the offer / bid shall be signed and stamped in each page by authorized representative of the bidder.
- e) Any additional documents submitted by supplier / bidder, during processing of registration application / tender or after placement of order shall not be accepted unless it is submitted with forwarding letter and duly signed and stamped.
- f) The bids of the bidders who are on the banned list and also the bids of the bidders, who engage the services of the banned firms, shall be rejected. The cutting / overwriting in the bid / offer must be duly attested by the signatories to the bid. The list of firms banned by BHEL is available on BHEL web site www.bhel.com.
- g) Being PMD vendor, if you are not quoting against this tender enquiry, please send your regret letter positively for our reference with valid reasons for not participating in the tender enquiry. Repeated lack of response on the part of bidder may lead to deletion such PMD vendor from BHEL's approved vendor list.
- h) The bidders will submit Integrity Pact, duly signed by its authorized signatory, along with their bids wherever estimated tender value is Rs. 2 Crore or more.
- i) In case of open tender, technically qualified unregistered bidders may apply online for registration through <http://www.bhel.com/index.php/vender>.
- j) BHEL reserves the right to award tendered quantities among more than one bidder (after acceptance of L1 price by the other bidders). BHEL can also consider awarding of part of the tendered quantity to other than L-1 bidder at L1 counter offered rates, if the quantity offered by the L-1 bidder is less than the quantity tendered for.
- k) In case of e-Tendering (Online bidding through e-portal), offline bid submitted in hard copy or in any other form by the vendor / supplier will not be accepted and will be rejected out rightly. Only e-portal bid will be accepted.

4. TENDER OPENING.

Tender opening is scheduled to start in the Tender Room at 2:00 PM, on the due date. Therefore, bid / quotations must reach this office / tender Box latest by 1:45 PM on due date. Only participating bidders are allowed to attend tender opening. **TENDERS RECEIVED AFTER THE SPECIFIED TIME OF THEIR 'SUBMISSION' WILL BE TREATED AS LATE TENDERS AND SHALL NOT BE CONSIDERED UNDER ANY CIRCUMSTANCES.** The bidders or their authorized representatives may be allowed to attend tender opening if duly authorized by their principals, through a tender specific letter on that particular day. General authorization letter is not acceptable.

Note: - Foreign bidders willing to attend the bid opening has to provide the requisite documents to the concerned Purchase executives for arranging gate pass for them.

5. SPECIFICATION, DRAWINGS & STANDARD.

- a) Bidders must give their detailed specification in the quotation along with relevant technical literature / catalogue etc. against the tender enquiry.
- b) The Bid should be accompanied with relevant copies of catalogues, drawings or specification as per tender enquiry.

Quotations / Bids not in accordance with General Instructions and Standard Terms & Conditions are likely to be ignored.



BHARAT HEAVY ELECTRICALS LIMITED

HEEP-HARIDWAR, UTTARAKHAND (249403)

General Instructions and Standard Terms & Conditions for bidding against Tender Enquiry (GISTC)

For Indian Bidders (Version June-2021, Rev: 06)

If these documents are not furnished, the offer is liable to be rejected.

- c) Wherever national / international (N/IN) standards are referred, the latest N/IN standards are to be followed. Mention year & date of standard revision that shall be followed for the supply.
- d) All Drawings and Standards are proprietary of BHEL. It must not be used in anyway detrimental to the interest of BHEL or without permission of BHEL.

6. PRICE SCHEDULE.

- a) Kindly quote your prices in figures and words both. In case of any discrepancy in value, the prices quoted in words shall be considered for evaluation and establishing L1 status.
- b) Prices quoted should not be more than the prices quoted to any other BHEL units / offices / divisions. Vendor to submit copy of latest Purchase Order placed by any unit of BHEL for similar items in the technical bid. In case no order has been placed on such items, specific confirmation that no order has been placed on such items should be provided.
- c) Prices should be quoted on F.O.R. Destination basis. Transit insurance shall be arranged by BHEL and not to be included in the prices. The offers quoted on other than F.O.R destination basis may result in non-consideration of such bids.
- d) In case BHEL accepts the EX-Works prices, such offers will be loaded by 1.5% of EX-Works value towards freight or with actual freight charges as per BHEL freight rate contract whichever is higher.
- e) In case of Indigenous items covered by DGS & D Rate Contract, the bidders should submit latest valid copy of the rate contract along with bid / quotation
- f) Applicable **IGST / CGST / SGST** and any other statutory levy should be indicated separately and clearly in the bid / quotation.

- g) Bidders can dispatch goods through any Indian Bank Association approved transporters having their branch at HARIDWAR / destination. If material is dispatched through other than Indian Bank Association approved transporter, material to be delivered on door delivery BHEL Stores basis.
- h) In case of dispatch of material through any other unapproved transporter, payment shall be made only after receipt of material and any additional charges payable to the transporter shall be to the bidder's account.
- i) Any demurrage / godown rent payable to the transporter / or to godown's owner due to any delay attributed by the supplier shall be recovered from supplier's account.
- j) Currency of Evaluation shall be INR.

NB: Financial evaluation of L1, L2Status will be on the basis of Landed Cost to BHEL.

7. REVERSE AUCTION.

Wherever RA is declared in the special terms and conditions of tender enquiry, following shall be applicable and Bidders to confirm the same:

"BHEL shall be resorting to Reverse Auction (RA) (Guidelines as available on www.bhel.com) for this tender. RA shall be conducted among all the techno-commercially qualified bidders.

Price bids of all techno-commercially qualified bidders shall be opened and same shall be considered as initial bids of bidders in RA. In case any bidder(s) do(es) not participate in online Reverse Auction, their sealed envelope price bid along with applicable loading, if any, shall be considered for ranking."

8. DELIVERY TERMS.

- a) Goods shall be delivered on 'FOR Destination' basis to the named destination unless otherwise called for in the tender enquiry.
- b) Loading on account of 3rd party inspection charges in case of Indian bidders shall be 0.20%.

Quotations / Bids not in accordance with General Instructions and Standard Terms & Conditions are likely to be ignored.



BHARAT HEAVY ELECTRICALS LIMITED

HEEP-HARIDWAR, UTTARAKHAND (249403)

General Instructions and Standard Terms & Conditions for bidding against Tender Enquiry (GISTC)

For Indian Bidders (Version June-2021, Rev: 06)

9. LIQUIDATED DAMAGES (LD) FOR LATE DELIVERY.

a) Where items of Purchase Order are independently usable.

Liquidated Damages (LD) for Late Deliveries shall be applicable @0.5% per week or part thereof on the value of respective delayed supplies subject to a maximum of 10% of the value of respective delayed supplies. Value of delayed supplies will mean the Gross Value payable to the vendor (Before LD) against such supplies excluding taxes and duties.

b) Where the total items are required for a main equipment and items are interdependent.

Liquidated Damages (LD) for Late Deliveries shall be applicable @0.5% per week or part thereof on total value of Purchase Order subject to maximum of 10% of the total value of Purchase Order. Purchase Order value for this purpose shall be the Total Gross Value payable to the vendor (Before LD) excluding taxes and duties.

c) Bidders are requested to quote the best delivery meeting the delivery requirements. BHEL reserves the right to reject the offers not meeting BHEL's delivery requirement.

d) Commencement of delivery period shall be reckoned from the date of PO / LOI or any other agreed milestone.

e) Bidder shall deliver the goods in the manner and schedule agreed under the terms and conditions of Purchase order.

f) DELIVERY IN CASE OF REJECTION: In case the material is rejected, then date of replacement will be considered as the actual date of delivery.

g) DELIVERY AGAINST BANK DOCUMENTS: In case payment terms quoted by bidder are documents through bank, and the delivery terms being "FOR Haridwar / FOR Transporter Go-down" then date of delivery will be date of intimation by transporter / bidder of delivery of material at Haridwar for the LD purpose.

h) Where the payments are through bank, the documents may be presented for negotiation to BHEL authorized / nominated bank.

i) Payment of Liquidated Damages (LD) shall not in any way relieve the vendor from any of its obligations & liabilities under the contract.

10. PAYMENT TERMS.

a) BHEL's standard payment term is Payment after receipt and acceptance of materials / items at HEEP, BHEL-Store or at desired destination unless otherwise specified in Special Terms attached to the tender enquiry.

b) BHEL reserves the right to accept or reject the offer of the bidder who quotes the payment term other than BHEL's standard payment term.

c) Loading on account of deviation in payment terms shall be done as per extant rules of BHEL-Haridwar.

d) 100% payment along with taxes, freight & insurance will be made after receipt and acceptance of material and within 75 days from the date of invoice subject to submission of non-discrepant documents within 15 days of supply as per terms and conditions of Purchase Order. In case any discrepancy found in the documents, BHEL will notify the same to vendor within 7 days of receipt. Vendor has to clear all the discrepancies in one go within 7 days thereafter else the payment of vendor may get delayed.

e) For MSEs (covered under MSME Act) which are registered and periodically renewed with BHEL, the payment will be made within 45 days or as prescribed in the relevant act.

f) Adherence to the above time schedule of payment is contingent upon Vendor complying with GST Rules w.r.t availment of Input Tax Credit by BHEL.

g) In case GST credit is delayed / denied to BHEL, due to non / delayed receipt of goods and / or tax invoice or expiry of the timeline prescribed in GST Law for availing such ITC, or any other reason not attributable to BHEL, GST amount shall be recoverable from Vendor along with interest levied / leviable on BHEL.

h) The taxes and duties that are reimbursed would be the ones applicable as on the contractual Purchase order delivery date or the amount actually paid whichever is less.



BHARAT HEAVY ELECTRICALS LIMITED

HEEP-HARIDWAR, UTTARAKHAND (249403)

General Instructions and Standard Terms & Conditions for bidding against Tender Enquiry (GISTC)

For Indian Bidders (Version June-2021, Rev: 06)

i) **The loading criteria for the different payment terms shall be as under;**

Payment Terms	Days of Loading
After Receipt & Acceptance of material within 75 days of supply.	No Loading
Against Delivery at BHEL-Stores Haridwar.	45
Against documents through bank (CAD):	45
Letter of Credit (LC)	120
Usance LC	No Loading if usance period is > 120 Days.
	Loading of days' difference i.e. difference between 120 days and usance period if the usance period is < 75 days.
Advance	Delivery Period + 120 Days - Advance Payment Days.

11. TAXES & DUTIES.

- a) The bidder to specify in their offer (part 1 bid) the category of their registration under GST like Registered, Unregistered and composite dealer.
- b) The provisional GST registration number of Bharat Heavy Electrical Ltd, Heavy Electricals Equipment Plant, Ranipur, Haridwar is "05AAACB4146P1ZL" with state Code as "05" and State Name as "Uttarakhand".
- c) Please quote our provisional GST registration number in all invoices raised for supply of goods and services under GST regime and also ensure filing of timely return and payment of tax and compliance of other applicable provisions on supplier under GST regime.
- d) No GST will be reimbursed to unregistered or composite dealer. In the event, any GST is quoted by composite dealer, the same shall be added to the cost of supply in evaluating the bid.
- e) Since, input credit of GST will be available to BHEL-Haridwar only after correct filing of return and payment of applicable GST by supplier, reimbursement of GST shall be made by

BHEL-Haridwar on matching of vendor inputs at GST portal, ensuring availability of input credit to BHEL Haridwar. Payment of GST will be made to vendor after matching of input credit and vendor to ensure submission of their invoices along with consent to accept payment of tax after such matching in all cases where bills are submitted directly to BHEL-Haridwar or through bank or under LC or through any other mode.

- f) In the event of any disallowance of input credit or applicability of interest or any other financial liability arises on BHEL-Haridwar due to any default of supplier under GST, such implication shall be to supplier's account.
- g) In the event of any change in the status of the vendor after the submission of the bid but before the supply, GST applicable at the time of supply or in the bid, based on the registration status of the vendor, whichever is lower shall be payable.
- h) Where ever applicable If PAN (Permanent Account Number) of the recipient is not available, income tax is deductible either at the normal rate or at the rate of 20 percent, whichever is higher as per Section 206AA of Indian Income Tax Act 1961.
- i) The bidder shall clearly indicate HSN (*Harmonised System Nomenclature*) / SAC (*Service Accounting Code*), its description and applicable rate of GST for each item in his techno-commercial bid.
- j) Statutory Variation in Taxes & duties as applicable at the time of supply shall be payable. However, in the event of no change in law but bidder quoting certain tax structure in bid document which is lower than the applicable one, such amount shall be the maximum amount of tax that can be claimed by bidder.
- k) **IMPORTED GOODS OFFERED BY INDIAN BIDDERS AGAINST DEALER INVOICE:** Wherever the material being offered is imported, the bidder must quote the prices inclusive of IGST. The rate and value of IGST as included in the price must be indicated separately. In case quantum of IGST is not mentioned by the bidder the same will not be considered for



BHARAT HEAVY ELECTRICALS LIMITED

HEEP-HARIDWAR, UTTARAKHAND (249403)

General Instructions and Standard Terms & Conditions for bidding against Tender Enquiry (GISTC)

For Indian Bidders (Version June-2021, Rev: 06)

evaluation. However, bidder will have to pass on the benefit of IGST to BHEL at the time supply.

- l) In case of directly dispatchable items to Customer's Site, BHEL-Haridwar will inform the GST registration number of the respective customer which must be mentioned on the vendor's invoice. Vendor to ensure availability of such information from BHEL-Haridwar before dispatch of any material. However, while filing GSTN-1, BHEL Haridwar GSTN number to be quoted.

Note: - Vendors must ensure compliance of all the applicable rules and procedure as envisaged in the GST Regime. Any loss to BHEL-Haridwar due to fault / non-compliance by the vendor will be to the vendor's account.

12. BANK GUARANTEE.

In case the bank guarantees are required to be deposited towards security deposit/performance guarantee or for any other purpose as per the terms of this tender enquiry, such bank guarantees of the requisite value in the denominated currency of the purchase order should be from one of the Indian branch of BHEL consortium banks and the bank guarantee should be in the proforma as prescribed by BHEL. The proforma of bank guarantee and the list of consortium banks are displayed at BHEL website www.bhelhwr.co.in. However, in case the bank guarantee is not from BHEL consortium banks, then the bidder has to get the bank guarantee confirmed from one of the Indian branch of BHEL consortium banks and the bank charges for such confirmation will be borne by the bidder.

13. GUARANTEE / WARRANTY AND CORRESPONDING REPAIRS / REPLACEMENT OF GOODS.

Goods shall comply with the specifications for material, workmanship and performance. Unless otherwise specified, the warranty shall be for a period of 18 months from the date of receipt. If the delivery is found non-compliant during the warranty period, leading to rejection, the Seller shall arrange free replacement / repair of goods, within one month from the date of intimation or any mutually agreed period. The rejected goods shall be taken away by the Seller at his cost and

replaced on Delivered Duty Paid (DDP) (FOR - BHEL Stores / designated destination basis) within such period. In the event of the Seller's failure to comply, Purchaser may take action as appropriate, including Repair / Replenish rejected goods & disposal of rejections, at the risk & cost of the Seller. In case the defects attributable to Seller are detected during processing of the goods at BHEL or at our subcontractor's works, the Seller shall be responsible for free replacement / repair of the goods as required by BHEL.

- b) **RETURN OF REJECTED MATERIAL FOR REPLACEMENT:** The bidder shall have to pay 5% incidental charges while taking back supplied material if it is found rejected on receipt. The rejected material shall be sent back only after receipt of replacement / submission of BG / refund of amount paid.

14. QUALITY REQUIREMENT.

Your bid / quotation should have specific confirmation regarding meeting all our quality requirements such as. (i) Test Certificate (TC), (ii) Guarantee Certificate (GC) / Warranty Certificate (WC), (iii) Quality Plan (QP) (if applicable); and (iv) Pre-Dispatch Inspection at your works (if applicable).

15. VALIDITY.

The quotation should be valid for a minimum period of 90 days effective from the date of opening of tender, unless otherwise specified in the tender enquiry.

16. RIGHT OF ACCEPTANCE.

- a) **BHARAT HEAVY ELECTRICALS LIMITED HARIDWAR** reserves the right to reject any or all the bids / quotations without assigning any reason thereof. BHEL also reserves the right to increase or decrease the tendered quantities. Bidders should be prepared to accept order for reduced quantity without any extra charges.
- b) Any discount / revised offer / bids submitted by a bidder on its own shall be considered, provided it is received on or before the due date and time of offer / bid submission (Part-1). Conditional discounts shall not be considered for evaluation of tenders.



BHARAT HEAVY ELECTRICALS LIMITED

HEEP-HARIDWAR, UTTARAKHAND (249403)

General Instructions and Standard Terms & Conditions for bidding against Tender Enquiry (GISTC)

For Indian Bidders (Version June-2021, Rev: 06)

- c) Unsolicited discounts / revised offers / bids given after Part-1 bid opening shall not be accepted. No change in price will be permitted within the validity period asked for in the tender enquiry.
- d) In case of changes in scope and / or technical specification and / or commercial terms & conditions having price implication, techno-commercially acceptable bidders shall be asked by BHEL to submit the impact of such changes on their price bids. In case a bidder opts to submit revised price bid instead of impact called for then the latest price bid shall prevail. However, in both situations, original price bid will be necessarily opened.
- e) The bidder whose bid is technically not accepted will be informed & EMD wherever submitted shall be returned after finalization of contract. EMD shall be forfeited in the event of bidder opting out after tender opening.
- f) BHEL reserves the right to short close the existing Purchase Order / Rate Contract / Work Order or any extension thereof at any stage.

17. TRANSIT INSURANCE.

- a) Transit Insurance will be covered by BHEL under its open Insurance Policy. Seller shall inform dispatch particulars (Purchase Order, RR /GR, Invoice value etc.) to "Finance department (Store bill Section), BHEL Ranipur, Haridwar (Uttarakhand-India) with value of consignment to the Purchaser within 07 days of dispatch for BHEL to arrange insurance coverage in its policy. Failure on the part of seller to inform dispatch particulars will make him liable to pay for any transit damages / losses suffered by the Purchaser.
- b) If Quoted Prices are inclusive of transit insurance, no weightage shall be given while evaluating the bids for Cost of Insurance, being in BHEL Scope.

18. RISK PURCHASE.

In case of abnormal delays (beyond the maximum late delivery period as per LD clause) in supplies / defective supplies or non-fulfillment of any other terms and conditions given in Purchase Order, BHEL may cancel the Purchase Order in full or part thereof, and may also make the purchase of such material from elsewhere / alternative source at the risk and cost of the supplier. BHEL will take all reasonable steps to get the material from alternate source at optimum cost. If bidder does not agree to the above Risk Purchase Clause, BHEL reserves the right to reject the offer. In case for compelling reasons BHEL accepts the offer without acceptance of this clause by the bidder and in the eventuality of Risk Purchase, appropriate action will be taken as per BHEL extant rules. This will be without prejudice to any other right of BHEL under the contract or under General Law.

19. FORCE MAJEURE CLAUSE.

Notwithstanding any other thing contained anywhere else in the contract or PO (Purchase Order), In case the discharge of obligation under the contract by either party is impeded or made unreasonably onerous, neither party shall be considered in breach of the contract to the extent that performance of their respective obligation is prevented by an event of Force Majeure that arises after the effective date (PO date).

In the above clause, Force Majeure means an event beyond the control of the parties to the contract which prevents a party from complying with any obligation of the contract including but not limited to:

- Act of God (Such as but not limited to earthquake, drought, tidal waves, floods etc.).
- War (whether war be declared or not), Hostilities Invasion, Act of foreign enemy etc.
- Rebellion, revolution, insurrection, civil war etc.
- Contamination of Radio Activity from any nuclear fuel or from any other nuclear waste or any other hazardous materials.
- Riots, commotions, strike unless restricted to the employees of supplier.
- Acts of terrorism.



BHARAT HEAVY ELECTRICALS LIMITED

HEEP-HARIDWAR, UTTARAKHAND (249403)

General Instructions and Standard Terms & Conditions for bidding against Tender Enquiry (GISTC)

For Indian Bidders (Version June-2021, Rev: 06)

- g) Other unforeseeable circumstances beyond the control of the parties and which the affected party cannot avoid even by using its best efforts.
- h) Cancellation of contract by customer.
- i) Change in law / government. Regulation making the performance impossible.
- j) Pandemic or Epidemic.

The party claiming to be affected by force majeure shall notify the other party in writing immediately without delay on the intervention and on the cessation of such circumstances.

Irrespective of any extension of time, if an event of force majeure occurs and its effect continues for more than 180 days the affected party shall have right to cancel the contract.

As soon as reasonably practicable following the date of commencement of a Force Majeure Event, and within a reasonable time following the date of termination of a Force Majeure Event, either Party invoking it shall submit to the other Party reasonable proof of the nature of the Force Majeure Event and of its effect upon the performance of the Party's obligations under this Agreement.

The party shall, and shall ensure that its Subcontractors shall, at all times take all reasonable steps within their respective powers and consistent with Good Operating Practices (but without incurring unreasonable additional costs) to:

- a) Prevent Force Majeure Events affecting the performance of the party's obligations under this Agreement.
- b) mitigate the effect of any Force Majeure Event and
- c) Comply with its obligations under this Agreement.

If the war like situation has developed in a country where a seller's works is located in this P.O. or there is political instability and Indian Embassy located in that country forbids or advises for not having any business dealing with the sellers located in such zone / region/ country, then BHEL reserves the right to cancel the order.

20. NON-DISCLOSURE AGREEMENT.

All Drawing and Technical Documents relating to the product or it's manufacture submitted by one party to the other, prior or

subsequent to the formation of contract, shall remain property of the submitting party. Drawing, technical documents or other technical information received by one party, shall not without the consent of the other party, be used for any other purpose than that, for which they were provided. Such technical information shall not without the consent of the submitting party, otherwise be used or copied, reproduced, transmitted or communicated to a third party. Patterns supplied by BHEL will remain BHEL's property which shall be returned by the bidder on demand to BHEL. Bidder shall in no way share or use such intellectual property of BHEL to promote his own business with others or to gain a commercial advantage. BHEL reserves the right to claim damages from the bidder, or take appropriate action as deemed fit against the bidder, for any infringement of the provisions contained herein as available under law or equity.

21. SETTLEMENT OF DISPUTES / ARBITRATION.

In case of any dispute arising out of as in connection with this contract, the same shall be referred to arbitration under Arbitration & Conciliation Act 1996 of a sole arbitrator who shall be appointed by mutual consent of the parties. The seat & venue of arbitration shall be Haridwar.

The proceedings shall be conducted in English. The Governing law of contract shall be the substantive law of India.

22. WHARFAGE / DEMURRAGE RESPONSIBILITY.

In the event of delay in receipt of documents by Manager (Stores-Shipping) BHEL-Haridwar and in case where dispatches are made through Unapproved Transporter the sole responsibility for wharfage / demurrage for such delay shall be that of supplier.

23. CONDITIONS FOR AVAILING MICRO & SMALL ENTERPRISES (MSE'S) BENEFITS.

- a) "MSE Suppliers can avail the intended benefits only if they submit along with the offer, attested copies of either EM II certificate having deemed validity (**five years** from the date of issue of acknowledgement in EM II) or valid NSIC certificate or EM II certificate along with attested copy of a CA certificate



BHARAT HEAVY ELECTRICALS LIMITED

HEEP-HARIDWAR, UTTARAKHAND (249403)

General Instructions and Standard Terms & Conditions for bidding against Tender Enquiry (GISTC)

For Indian Bidders (Version June-2021, Rev: 06)

(Format enclosed at annexure-1 where deemed validity of EM II certificate of five years has expired) applicable for the relevant financial year (latest audited). Date to be reckoned for determining the deemed validity will be the date of bid opening (Part 1 in case of two-part bid) or vendor has to give Udyog Adhar Memorandum (UAM). Non submission of such documents will lead to consideration of their bid at par with other bidders. No benefit shall be applicable for this enquiry if any deficiency in the above required documents is found or the requisite documents are not submitted before price bid opening. If the tender is to be submitted through e-procurement portal, then the above require document are to be uploaded on the portal. Documents should be notarized or attested by a Gazetted officer. **UAM need not required to be notarized or attested.**

b) Any new supplier will be eligible for registration with BHEL as MSE supplier provided at least any one of the following documents are submitted along with application for registration: -

1. Udyog Adhar Memorandum (UAM).
2. Valid National Small Industries Commission (NSIC) Certificate.
3. Entrepreneurs Memorandum part II (EM II) certificate (valid based on deemed validity of 5 years) or
4. EM II certificate along with attested copy of CA Certificate (as per prescribed format at annexure-A) applicable for the relevant financial year (latest audited), where the deemed validity of EM II is over.
5. However, credentials of all MSE suppliers will be verified before advancing the intended benefits.
6. MSE bidders claiming SC/ST status will have to submit SC/ST certificate of the Proprietor from competent authority. Attested (notarized or attested by Gazetted officer) copy to be submitted along with the offer.
7. In case techno-commercial accepted bidders include MSE source and their prices (based on landed cost – considering quoted prices) are within the price band of 15% w.r.t. L-1 bidder, then BHEL can offer **25%** of quantity of respective item (rounded off to nearest number) to MSE bidders at L-1 price and in case, more than one MSE bidder is in 15 % band and the same is accepted by more than one MSE bidders then **25%** quantities of respective items will be considered for ordering on proportionate basis amongst MSE bidders.
8. There will be minimum of **3%** reservation for women owned MSEs within the above mentioned 25% reservation.
9. The reservation for MSEs owned by SC/ST will be **6.25%** { 25% out of target of 25% - refer para 4 of Public Procurement Policy for the Micro and Small Enterprises(MSEs)}.
10. The definition of MSEs owned by Women Entrepreneurs is clarified as under:
 - a) In case of proprietary MSE, proprietor shall be Woman.
 - b) In case of partnership MSE, the Woman partners shall be holding at least 51% of share in the unit.
 - c) In case of Private Limited companies, at least 51% share shall be held by Women promoters.
11. The definition of MSEs owned by SC/ST is clarified as under:
 - a) In case of proprietary MSE, proprietor(s) shall be SC/ST.
 - b) In case of partnership MSE, the SC/ST partners shall be holding at least 51% of shares in the unit.
 - c) In case of Private Limited companies, at least 51% share shall be held by SC/ST promoters.
12. While distributing the **25%** quantity amongst MSE bidders the decimal points in quantity shall be ignored for all the bidders except the L-1 amongst MSE bidders. Balance quantity after allocating the quantity to other MSE bidders ignoring the quantities in decimal, shall be given to L-1 (amongst MSE) bidder. However, if there are more than one MSE bidder at the same price level than preference for additional quantities due to ignoring off the decimal (as mentioned above) shall be given to the bidder offering favorable terms to BHEL and if the conditions offered are also same then preference will be given to the bidder having high SPR rating.
13. In case there are more than one MSE bidders (with different landed cost to BHEL) within 15% price band of lowest bidder and quantity to be offered is 1 no. only, then preference shall be given to the MSE bidder with lowest landed cost.
14. In case there are more than one MSE bidders (with same landed cost to BHEL) within 15% price band of lowest bidder and quantity to be offered is 1 no. only, then preference shall be given first, based on the favorable terms in the bid and in case terms are also same, the bidder with high SPR rating shall be given preference.
15. If L1 bidder is MSE bidder, entire quantity will be given to such MSE bidder only.

Quotations / Bids not in accordance with General Instructions and Standard Terms & Conditions are likely to be ignored.



BHARAT HEAVY ELECTRICALS LIMITED

HEEP-HARIDWAR, UTTARAKHAND (249403)

General Instructions and Standard Terms & Conditions for bidding against Tender Enquiry (GISTIC)

For Indian Bidders (Version June-2021, Rev: 06)

16. Note: It may however be noted that MSE guidelines as on date (Date of Technical Bid Opening Part-1) shall prevail.

17. "As per the OM No. F.No. 1(2)(1)/2016-MA dtd. 09.02.2017 issued from the Office of Development Commissioner (Micro, Small & Medium Enterprises), "Traders and agents should not be allowed to avail the benefits extended under the PP Policy."

In view of this, it is clarified that benefits of MSE (such as EMD Waiver, Tender fee exemption, Price preference, Payment preference etc.) will be given only to those MSE Vendors who are manufacturers of offered items against the NIT. No MSE benefits shall be provided to Agents / Stockists / Dealers / Traders etc. for the items offered but not manufactured by themselves."

24. INFORMATION TO THE BIDDERS.

a) Purchase related information is available at our Business-to-Business (B2B) Portal available on our website <https://hwr.bhel.com>. The user ID & password can be obtained by sending a request to concerned purchase executives.

b) Intimate your change in mail address or communication address or changes, if any, by email to AGM (SDX/MM) giving your bidder Code.

c) Please resolve your rejections and unexecuted overdue purchase order immediately which are posted at our B2B Portal, which can be visited through our site <https://hwr.bhel.com>

d) Copy of this Tender Enquiry is being sent through the post.

e) The Bidder declares that they will not enter into any illegal or undisclosed agreement or understanding, whether formal or informal with other bidder(s). This applies in particular to prices, specifications, certifications, subsidiary contracts, submission or non-submission of bids or any other actions to restrict competitiveness or to introduce cartelization in the bidding process.

In case, the bidder is found having indulged in above activities, suitable action shall be taken by BHEL as per extant policies/guidelines.

f) Supplier must upload digitally signed e-Invoice on B2B portal for processing of Bills.

In other cases, inked signed hard copy of Invoice to be submitted for processing of Bills.

25. MAKE IN INDIA (GOVT-NOTIFICATION).

A. This tender enquiry shall be governed by notification no. P-45021/2/2017-PP (BE-II) dated 04.06.2020 of government of INDIA and subsequent circulars issued afterwards. Accordingly, the minimum local content, the margin of purchase preference and the procedure for preference to make in INDIA shall be adhered.

B. The margin of purchase preference shall be 20%.

- 'Class-I local Supplier' means a supplier or service provider, whose goods, services or works offered for procurement, has local content equal to or more than 50%, as defined under this order.
- 'Class-II local Supplier' means a supplier or service provider, whose goods, services or works offered for procurement, has local content more than 20% but less than 50%, as defined under this order.
- 'Non- local Supplier' means a supplier or service provider, whose goods, services or works offered for procurement, has local content less than or equal to 20%, as defined under this order.

C. Vendor to specifically confirm if they are Class-I or Class-II local supplier or not as per above mentioned notification. Accordingly, the 'Class-I local supplier' / 'Class-II local Supplier' at the time of tender, bidding or solicitation shall be required to indicate percentage of local content and provide self-certification that the item offered meets the local content requirement for 'Class-I local supplier' / 'Class-II local Supplier', as the case may be. They shall also give details of the location(s) at which the local value addition is made.

D. In cases of Procurement for a Value in Excess of Rs. 10 Crores, the 'Class-I local supplier' / 'Class-II local Supplier' shall be required to provide a Certificate from the Statutory Auditor or Cost Auditor of the Company (in the case of companies) or from a practicing Cost Accountant or practicing Chartered Accountant (in respect of suppliers other than companies) giving the percentage of Local Content.



BHARAT HEAVY ELECTRICALS LIMITED

HEEP-HARIDWAR, UTTARAKHAND (249403)

General Instructions and Standard Terms & Conditions for bidding against Tender Enquiry (GISTC)

For Indian Bidders (Version June-2021, Rev: 06)

E. Requirement of Purchase Preference:

Purchase preference shall be given to 'Class-I local supplier' in procurements undertaken by procuring entities in the manner specified hereunder -

a. In the procurements of goods or works, which are covered by para 3(b) of mentioned Govt. circular and which are divisible in nature, the 'class-I local supplier' shall get purchase preference over 'Class-II supplier' as well as 'Non-local supplier', as per following procedure:

- i. Among All qualified bids, the lowest bid will be termed as L1. If L1 is 'Class-I local supplier', the contract for full quantity will be awarded to L1.
- ii. If L1 bid is not a 'Class-I local supplier', 50% of the order quantity shall be awarded to L1. Thereafter, the lowest bidder among the 'Class-I local supplier' will be invited to match the L1 price for the remaining 50% quantity subject to the class-I local supplier's quoted price falling within the margin of purchase preference, and contract for that quantity shall be awarded to such 'Class-I local supplier' subject to matching the L1 price. In case such lowest eligible 'Class-I local supplier' fails to match the L1 price or accepts less than the offered quantity, the next higher 'Class-I local supplier' within the margin of purchase preference shall be invited to match the L1 price for remaining quantity and so on, and contract shall be awarded accordingly. In case some quantity is still left uncovered on Class-I local supplier, then such balance quantity may also be ordered on the L1 bidder".

b. In the procurements of goods or works, which are covered by para 3(b) of mentioned Govt. circular and which are not divisible in nature, and in procurement of services where the bid is evaluated on price alone, the 'class-I local supplier' shall get purchase preference over 'Class-II supplier' as well as 'Non-local supplier', as per following procedure:

- i. Among all qualified bids, the lowest bid will be termed as L1. If L1 is 'Class-I local supplier', the contract will be awarded to L1.
- ii. If L1 is not 'Class-I local supplier', the lowest bidder among the 'Class-I local supplier', will be invited to match the L1 price subject to Class-I local supplier's quoted price falling

within the margin of purchase preference, and the contract shall be awarded to such 'Class-I local supplier' subject to matching the L1 price.

- iii. In case such lowest eligible 'Class-I local supplier', fails to match the L1 price, the 'Class-I local supplier' with the next higher bid within the margin of purchase preference shall be invited to match the L1 price and so on and contract shall be awarded accordingly. In case none of the 'Class-I local supplier' within the margin of purchase preference matches the L1 prices, the contract may be awarded to the L1 bidder.

c. 'Class-II local supplier' will not get purchase preference in any procurement, undertaken by procuring entities.

F. For this procurement, the local content to categorize a supplier as a Class-I local supplier/ Class-II local supplier/ Non-local supplier and purchase preference to Class-I local supplier, is as defined in Public Procurement (Preference to Make in India), Order 2017 dated 04.06.2020 issued by DPIIT. In case of subsequent orders issued by nodal ministry, changing the definition of local content for the items of the NIT, the same shall be applicable even if issued after issue of this NIT, but before opening of Part-II bids against this NIT.

G. Procurements where estimated value to be procured is less than Rs. 5 lakhs shall be exempted from GOI order No. P-45021/2/2017-PP (BE-II) dated 04.06.2020.

H. For procurement of Goods & Services which are divisible in nature, following shall be operated for **MSE bidders** under Public procurement Policy for the Micro and Small Enterprises (MSEs) Amendment Order, 2019, Ref. No. AA:SSP: MSE: Amndt, dtd. 30.11.2018, Circular No. 44 of 2018-19;-

a. If L1 bid is not from "Class-I local Supplier" and price quoted by MSE bidder falls within the margin of Purchase preference (L1+15% for MSEs), then 25 % of total order quantity of respective item (rounded off to nearest number) shall be awarded to MSE bidder, subject to MSE bidder matching the L1 Price. Out of Remaining 75% quantity, distribution shall be operated as per below sub-clause (2) –

b. If "Class- I Local Supplier" (Next to L1, other than MSE) quoted price falling within the Margin of Purchase Preference, and "Class-I local supplier" matches the L1 price,



BHARAT HEAVY ELECTRICALS LIMITED

HEEP-HARIDWAR, UTTARAKHAND (249403)

General Instructions and Standard Terms & Conditions for bidding against Tender Enquiry (GISTC)

For Indian Bidders (Version June-2021, Rev: 06)

then 50% of remaining Quantity (after allocation of 25% to MSE) i.e. 37.5% shall be awarded to local supplier and 37.5% shall be awarded to foreign bidder.

Note: L1 Price refers to lowest evaluated / landed cost to Company.

For Further details, please refer GOI order no. P-45021 / 2 / 2017 - PP (BE-II) dated 04.06.2020.

26. RESTRICTIONS UNDER RULE 144(XI) OF THE GENERAL FINANCIAL RULES (GFRs), 2017

All provisions of Order No. F.No.6/18/2019-PPD of Department of Expenditure (DoE) shall be applicable for this tender enquiry (Order copy is available at <https://doe.gov.in/procurement-policy-divisions>). Accordingly, any bidder from a country which shares a land border with India (except the countries to which the Govt. of India has extended lines of credit or in which the Govt. of India is engaged in development projects for which list is available at <https://www.mea.gov.in/>) will be eligible to bid in this tender only if the bidder is registered with the Competent Authority as specified in Annex I of the said Order of DoE.

Updated list of the countries to which lines of credit have been extended or in which development projects are undertaken are available on the Ministry of External affairs website (<https://www.mea.gov.in/>)

For the purpose of this order, definition of Bidder from a country which shares a land border with India shall be same as defined in the Annex III of the said order.

Registration with the competent authority as stipulated in the said order is responsibility of bidder. Bidder has to submit a certificate certifying following along with offer:

"I have read the clause regarding restrictions on procurement from a bidder of a country which shares a land border with India; I certify that bidder (.... Name of Bidder) is not from such a country or, if from such a country, has been registered with the Competent Authority. I hereby certify that bidder (.....Name of bidder) fulfils all requirements in this regard and is eligible to be considered"

If the bidder is from such country which shares a land border with India evidence of valid registration by the Competent Authority shall also be attached along with offer."

27. NOTE.

- a) Special conditions of enquiry, if enclosed by BHEL, will supersede the respective standard / general terms of enquiry.
- b) Any other Standard terms and Conditions of the bidder attached / referred against the tender enquiry will be treated as null and void ab initio.
- c) In order to protect the commercial interests of BHEL, it becomes necessary to take action against suppliers / contractors by way of suspension of business dealings, who either fail to perform or are in default without any reasonable cause, cause loss of business / money / reputation, indulged in malpractices, cheating, bribery, fraud or any other misconducts or formation of cartel so as to influence the bidding process or influence the price etc. Guide- lines for Suspension of Business Dealings with Suppliers / Contractors shall prevail over which is available at BHEL website <http://www.bhel.com>
- d) The bidder along with its associate / collaborators / sub-contractors / sub-vendors / consultants / service providers shall strictly adhere to BHEL Fraud Prevention Policy displayed on BHEL website <http://www.bhel.com> and shall immediately bring to the notice of BHEL-Management about any fraud or suspected fraud as soon as it comes to their notice.
- e) "BHEL shall recover the amount of compensation paid to victim(s) by BHEL towards loss of life / permanent disability due to an accident which is attributable to the negligence of contractor, agency or firm or any of its employees as detailed below;
 1. **Victim:** Any person who suffers permanent disablement or dies in an accident as defined below.
 2. **Accident:** Any death or permanent disability resulting solely and directly from any unintended and unforeseen injurious

Quotations / Bids not in accordance with General Instructions and Standard Terms & Conditions are likely to be ignored.



BHARAT HEAVY ELECTRICALS LIMITED

HEEP-HARIDWAR, UTTARAKHAND (249403)

General Instructions and Standard Terms & Conditions for bidding against Tender Enquiry (GISTC)

For Indian Bidders (Version June-2021, Rev: 06)

occurrence caused during the manufacturing / operation and works incidental thereto at BHEL factories/ **offices and precincts** thereof , project execution , erection and commissioning, services, repairs and maintenance, trouble shooting, serving , overhaul, renovation and retrofitting , trial operation, performance guarantee testing undertaken by the company or during any works / during working at BHEL Units/ Offices/ townships and premises/ project sites.

3. Compensation in respect of each of the victims:

- (i) In the event of death or **permanent disability** resulting from **Loss of both limbs**: Rs. 10,00,000/- (Rs. Ten Lakh).
- (ii) In the event of **other permanent disability**: Rs. 7,00,000/- (Rs. Seven Lakh).

4. Permanent Disablement: A disablement that is classified as a permanent total disablement under the proviso to Section 2(l) of the Employees Compensation Act, 1923.”

f) The bidder shall be in compliance with applicable laws, rules and regulations throughout the terms of the contract for conducting its business generally and to perform its obligations under this contract.



BHARAT HEAVY ELECTRICALS LIMITED

HEEP-HARIDWAR, UTTARAKHAND (249403)

General Instructions and Standard Terms & Conditions for bidding against Tender Enquiry (GISTC)
For Foreign Bidders (Version June-2021,Rev: 06)

Table of Contents

1. GENERAL.....	1
2. ORIGIN OF QUOTATION.....	1
3. SUBMISSION OF TENDER.....	1
4. TENDER OPENING.....	3
5. SPECIFICATION, DRAWINGS & STANDARD.....	3
6. PRICE SCHEDULE.....	3
7. REVERSE AUCTION.....	4
8. DELIVERY TERMS.....	4
9. LD FOR LATE DELIVERY.....	6
10. PAYMENT TERMS.....	6
11. BANK GUARANTEE.....	7
12. GUARANTEE / WARRANTY AND CORRESPONDING REPAIRS / REPLACEMENT OF GOODS.....	7
13. QUALITY REQUIREMENT.....	7
14. VALIDITY.....	8
15. RIGHT OF ACCEPTANCE.....	8
16. TRANSIT INSURANCE.....	8
17. PHYTOSANITARY CERTIFICATE.....	8
18. RISK PURCHASE.....	8
19. FORCE MAJEURE CLAUSE.....	9
20. NON-DISCLOSURE AGREEMENT.....	9
21. SETTLEMENT OF DISPUTES/ARBITRATION.....	10
22. INFORMATION TO THE BIDDERS.....	10
23. MAKE IN INDIA (GOVT-NOTIFICATION).....	10
24. RESTRICTIONS UNDER RULE 144(xi).....	12
25. NOTE.....	13

1. GENERAL.

These general terms & conditions shall apply to all the Tender Enquiries, notice inviting tenders, request for quotations concerning the supply of goods and / or rendering of services to Bharat Heavy Electricals Ltd., HEEP, Haridwar (hereinafter referred to as BHEL or the Purchaser). In case of placement of order these conditions will become part of purchase order until unless the deviations are specifically agreed by BHEL.

2. ORIGIN OF QUOTATION.

- The quotation should preferably be from the principal bidder. However tender specific authorized registered dealer / agent can also submit the bid on their behalf, failing which the quotation is liable to be ignored. BHEL prefers to deal directly with the principal manufacturers.
- An agent cannot quote on behalf of more than one principal in the same Tender Enquiry.

3. SUBMISSION OF TENDER.

- Bid/Quotation must be enclosed in sealed cover on which tender enquiry number and the due date MUST BE written and be invariably sent under REGISTERED POST / SPEED POST / COURIER/Dropped in the Tender Box: addressed as follows: -

Quotation against Enquiry No. _____ Dated: _____

Due on: _____

To,
THE HEAD OF MATERIALS MANAGEMENT,
Heavy Electrical Equipment Plant,
Bharat Heavy Electricals Limited,
HARIDWAR-249403 (Uttarakhand), INDIA.

- TENDER BOX is located at TENDER ROOM, Room No. - 415, 4th Floor, Main Admin. Building, BHEL-HEEP, Haridwar.

Quotations / Bids not in accordance with General Instructions and Standard Terms & Conditions are likely to be ignored.



BHARAT HEAVY ELECTRICALS LIMITED

HEEP-HARIDWAR, UTTARAKHAND (249403)

General Instructions and Standard Terms & Conditions for bidding against Tender Enquiry (GISTC)
For Foreign Bidders (Version June-2021,Rev: 06)

- C) In case of Three / Two Part Bid, technical bid containing technical offer, duly signed; and un-priced copy of the Price Bid should be kept in one envelope. Price Bid containing only the price should be kept in a separate envelope. All envelopes indicating Part-1 or Part-2 or Part-3 as the case may be to be put in a bigger envelope. Please note that un-priced bid should be the exact replica of price bid but without prices.
- D) The bid / quotation must be posted before due date, keeping allowance for postal transit time. Quotations sent by any mode but not received in time will be ignored. Tender received through authorized E-mail is also acceptable. However, in time submission of tender in tender box shall be the responsibility of the bidder, sent through any mode. Documents submitted with the offer / bid shall be signed and stamped in each page by authorized representative of the bidder.
- E) Any additional documents submitted by supplier / bidder, during processing of registration application / tender or after placement of order shall not be accepted unless it is submitted with forwarding letter and duly signed and stamped.
- F) The bids of the bidders who are on the banned list and also the bids of the bidders, who engage the services of the banned firms, shall be rejected. The cutting / overwriting in the bid / offer must be duly attested by the signatories to the bid. The list of firms banned by BHEL is available on BHEL web site www.bhel.com.
- G) Being PMD vendor, if you are not quoting against this tender enquiry, please send your regret letter positively for our reference with valid reasons for not participating in the tender enquiry. Repeated lack of response on the part of bidder may lead to deletion of such PMD vendor from BHEL's approved vendor list.

- H) The bidders will submit Integrity Pact, duly signed by its authorized signatory, along with their bids wherever estimated tender value is Rs. 2 Crore or more.
- I) In case of open tender, technically qualified unregistered bidders may apply online for registration through <http://www.bhel.com/index.php/vender>.
- J) BHEL reserves the right to award tendered quantities among more than one bidder (after acceptance of L1 price by the other bidders). BHEL can also consider awarding of part of the tendered quantity to other than L-1 bidder at **L1 counter offered rates**, if the quantity offered by the L-1 bidder is less than the quantity tendered for.

If the counter offer is to be given to other qualifying Vendor(s) (e.g. in case of splitting of order, MSE Vendors or the case of Purchase preference to make in India), then the basic price for each qualifying vendor has to be calculated taking the landed cost of the L1 vendor as reference. Basic price will be calculated by working backwards from the landed cost of L1 vendor in following manners;

(1) Counter offer in case of MSE Vendor(s) or the case of Purchase preference to make in India:

Landed cost of L-1 vendor will be reduced by notional loading of late delivery penalty to the extent the same is not applicable to the vendor being counter offered. The result so arrived at will be put as landed cost and basic price to be counter offered will be worked backward therefrom in price structure of the concerned vendor.

(2) Counter offer in case of Splitting:

Landed cost of L-1 vendor will be reduced by custom duty and notional loading of late delivery penalty to the extent the same is not applicable to the vendor being counter offered. The result so arrived at will be put as landed cost and basic price to be counter offered will be worked backward therefrom in price structure of the concerned vendor.

Quotations / Bids not in accordance with General Instructions and Standard Terms & Conditions are likely to be ignored.



BHARAT HEAVY ELECTRICALS LIMITED

HEEP-HARIDWAR, UTTARAKHAND (249403)

General Instructions and Standard Terms & Conditions for bidding against Tender Enquiry (GISTC)
For Foreign Bidders (Version June-2021,Rev: 06)

If the basic price so computed is less than the basic price of the L1 vendor, then this basic price shall be counter offered, otherwise the basic price of L1 vendor shall be counter offered.

- K) BHEL may also reduce the Tender Quantity for offering it to Micro & Small Enterprise (MSE) Indian Vendors as per applicable Government of India rules whose prices are within 15% of L1 prices as per directives of Government of India.
- L) In case of e-Tendering (Online bidding through e portal), offline bid submitted in hard copy or in any other form by the vendor / supplier will not be accepted and will be rejected outrightly. Only e-portal bid will be accepted.

4. TENDER OPENING.

Tender opening is scheduled to start in the Tender Room at 2:00 PM, on the due date. Therefore, bid / quotations must reach this office / tender Box latest by 1:45 PM on due date. Only participating bidders are allowed to attend tender opening. **TENDERS RECEIVED AFTER THE SPECIFIED TIME OF THEIR 'SUBMISSION' WILL BE TREATED AS LATE TENDERS AND SHALL NOT BE CONSIDERED UNDER ANY CIRCUMSTANCES.** The bidders or their authorized representatives may be allowed to attend tender opening if duly authorized by their principals, through a tender specific letter on that particular day. General authorization letter is not acceptable.

Note: - Foreign bidders willing to attend the bid opening has to provide the requisite documents to the concerned Purchase executives for arranging gate pass for them.

5. SPECIFICATION, DRAWINGS & STANDARD.

- a) Bidders must give their detailed specification in the quotation along with relevant technical literature / catalogue etc. against the tender enquiry.
- b) The Bid should be accompanied with relevant copies of catalogues, drawings or specification as per tender enquiry.

If these documents are not furnished, the offer is liable to be rejected.

- c) Wherever national / international (N/IN) standards are referred, the latest N/IN standards are to be followed. Mention year & date of standard revision that shall be followed for the supply.
- d) All Drawings and Standards are proprietary of BHEL. It must not be used in anyway detrimental to the interest of BHEL or without permission of BHEL.

6. PRICE SCHEDULE.

- a) Kindly quote your prices in figures and words both. In case of any discrepancy in value, the prices quoted in words shall be considered for evaluation and establishing L1 status.
- b) Prices quoted should not be more than the prices quoted to any other BHEL units / offices / divisions. Vendor to submit copy of latest Purchase Order placed by any unit of BHEL for similar items in the technical bid. In case no order has been placed on such items, specific confirmation that no order has been placed on such items should be provided.
- c) Bidders need to quote their prices on CFR any sea port in Mumbai or FCA basis to the named airport in Euro/USD/JPY/UK Pound/SF/Singapore Dollar or any other Internationally freely tradable currency only. The name of the currency should be clearly indicated in your bids.
- d) In case the vendor quotes the prices on CFR basis and BHEL accepts the delivery term on CFR, **0.25 %** (of CFR Value) towards port handling charges & **1.5 %** (of CFR Value) towards inland freight or actual freight charges as per BHEL freight rate contract whichever is higher, shall be loaded in the prices for ascertaining the landed cost to decide the comparative status of the prices.
- e) However, if BHEL agrees to accept the FOB delivery terms, the FOB prices shall be loaded **2.0%** (of FOB Value) towards sea freight, **0.25%** (of FOB Value) towards port handling charges & **1.5%** (of FOB value) towards inland freight for

Quotations / Bids not in accordance with General Instructions and Standard Terms & Conditions are likely to be ignored.



BHARAT HEAVY ELECTRICALS LIMITED

HEEP-HARIDWAR, UTTARAKHAND (249403)

General Instructions and Standard Terms & Conditions for bidding against Tender Enquiry (GISTC)
For Foreign Bidders (Version June-2021,Rev: 06)

ascertaining the landed cost to decide the comparative status of the prices.

f) Basis of Evaluation for Bid / Quotation in foreign currency:

1. Currency exchange rate (TT selling rates of SBI) for evaluation of the bid / quotation received in foreign currency will be as follows:
2. Single part bid – Date of tender opening.
3. Two / Three-part bid – Date of part 1 opening.
4. Reverse auction – Date of part-1 opening.

Note: - Financial evaluation of L1, L2 ----- status will be on the basis of Landed Cost to BHEL.

f1) Currency of Evaluation shall be INR.

g) Evaluation of Indian Agents Commission:

1. BHEL prefers to deal directly with foreign bidder, wherever required, for procurement of Goods. However, if the Foreign Principal desires to avail services of an Indian Agent then the Principal should ensure compliance to applicable guidelines.
2. The FOB / CIF price quoted will be deemed to be inclusive of Indian Agency commission. Agency commission if payable shall be converted to Indian Rupees at TT buying rates of exchange ruling on tender opening date which shall not be subjected to any further exchange rate variation, as disclosed by the bidder in his quoted FOB / CIF price will be paid in Indian Rupees on receipt & acceptance of Materials or it's installation at destination, as the case may be. The lower of the TT buying rate prevailing on the date of technical bid opening shall be considered for computation of Agency commission.
3. In a tender either the Indian Agent on behalf of Principal / OEM or the Principal / OEM itself can bid, but both cannot bid simultaneously for same item / product in the same Tender. If both OEM and its authorized agent submit their bids separately in that case only the offer of OEM can be considered as an exception.

h) While submitting your bids please clearly indicate:

1. Expected weight of goods (lots wise).
2. The size of packed goods.
3. Whether the goods can be dispatched in containers?
4. Port of Loading.
5. Port of Discharge.

7. REVERSE AUCTION.

Wherever RA is declared in the special terms and conditions of tender enquiry, following shall be applicable and Bidders to confirm the same:

"BHEL shall be resorting to Reverse Auction (RA) (Guidelines as available on www.bhel.com) for this tender. RA shall be conducted among all the techno-commercially qualified bidders.

Price bids of all techno-commercially qualified bidders shall be opened and same shall be considered as initial bids of bidders in RA. In case any bidder(s) do(es) not participate in online Reverse Auction, their sealed envelope price bid along with applicable loading, if any, shall be considered for ranking."

8. DELIVERY TERMS.

- a) Goods shall be dispatched by sea, unless stated otherwise in the tender enquiry or purchase order.
- b) Specifically confirm your agreement to change the mode by Air at BHEL's request as per mutually agreed terms even after placement of Purchase Orders.
- c) The Trans-shipment is not permissible in case of Break Bulk Cargo. In rest of the case Trans-shipment condition in BHEL purchase order / letter of credit will be as per Uniform Custom and Practice for documentary credits, UCP 600 of International Standard Bank proceed re-issued by International chamber of Commerce (ICC).

Quotations / Bids not in accordance with General Instructions and Standard Terms & Conditions are likely to be ignored.



BHARAT HEAVY ELECTRICALS LIMITED

HEEP-HARIDWAR, UTTARAKHAND (249403)

General Instructions and Standard Terms & Conditions for bidding against Tender Enquiry (GISTC)
For Foreign Bidders (Version June-2021,Rev: 06)

- d) Any demurrage / Godown Rent payable to the Port Authorities due to any delay attributed by the supplier will be recovered from supplier's account.
- e) A certificate of origin (COO) sanctioned in country of origin from chamber of commerce of the manufacturing country is to be provided mandatorily. However, a certificate of origin (COO) from the countries under the restricted list of Govt. of India will not be acceptable.
- f) For reasons of delay in receipt of documents from suppliers or due to the same being found to be incomplete, and / or faulty, the suppliers shall be responsible to reimburse in all demurrages / wharfages, if any paid by BHEL (for stated reasons).
- g) Load port charges shall be settled by the supplier and not be passed on to BHEL in form of destination charges.
- h) In the event of bidder offering CFR delivery terms for delivery in FCL (Full Container Load), the bidder shall provide 21 days' time free of detention for General Purchase Container / High Cube Container and 14 days for the other types from the date of delivery at delivery port. Wherever the detention free period offered is less than the above specified period, the consequential cost at port of clearance shall be to the account of the bidder. Number of detention free days must be mentioned on Bill of Lading (BL).
- i) In case of CFR delivery, Port congestion charges or any additional charges claimed by shipping line till delivery at destination port shall be to the bidder's account.
- j) The shipping line should be ready to move the containers to consignees nominated CFS (Container Freight Station) yard and Indian agent of shipping line should issue Cargo Arrival Notice (CAN) 7 days in advance for filing the IGM (Import General Manifest) at discharge port.
- k) In case of CFR contract, bidder to supply the material through a Certified Sea worthy vessel.
- l) **The invoices being issued by shipping lines must be in the name of BHEL. Any loss in GST due to submission of discrepant document will be recovered from supplier / vendor.**
- m) While booking the shipment, bidder to also finalize **destination charges** and the same should appear over BL or agreed tariff to be provided to BHEL before arrival of shipment.
- n) If cargo is stuffed in container, then the same should be allowed to be moved to CFS of importers choice without any additional charges.
- o) NNDs (Non Negotiable Documents) (preferably with OBLs) should be sent to BHEL as detailed in para "p" (below), at least 7 days in advance i.e. 7 days before the arrival of vessel so as to enable BHEL to move the containers to JWC CFS.
- p) **Information related to OBL / AWB Documents:**
- I. Consignee name and address should be same as mentioned in the Purchase order.
- II. Notify party: Name and address will be as follows :(For discharge port Mumbai or Nhava Sheva)
Bharat Heavy Electricals Limited
14th Floor World Trade Centre-1, Cuffe Parade, Colaba, Mumbai -400005
Email: msseahwr@bhel.in & ppximx@bhelh.in (in case of Sea Shipments)
Email: msair@bhel.in and ppximx@bhel.in (in Case of Air shipments)
- For latest updating please refer our web site:
<https://hwr.bhel.com>
- III. OBL should clearly mention the Indian agent address and contact details.
- IV. OBL should be issued as per UCP 600.
- V. In case of shipments other than FOB, OBL should mention the container detention free period.

Quotations / Bids not in accordance with General Instructions and Standard Terms & Conditions are likely to be ignored.



BHARAT HEAVY ELECTRICALS LIMITED

HEEP-HARIDWAR, UTTARAKHAND (249403)

General Instructions and Standard Terms & Conditions for bidding against Tender Enquiry (GISTC)
For Foreign Bidders (Version June-2021,Rev: 06)

VI. In case of placement of an Order, BHEL requests bidder to supply one Original Bill of Lading / AWB directly to BHEL-Mumbai office (Address at Para "p-II") with other non-negotiable documents to ensure timely clearance of goods. The other Original Bill of Ladings (BL) may be routed through bank based on the other agreed terms and conditions of purchase order.

9. LIQUIDATED DAMAGES (LD) FOR LATE DELIVERY.

a) Where items of Purchase Order are independently usable.

Liquidated Damages (LD) for Late Deliveries shall be applicable @0.5% per week or part thereof on the value of respective delayed supplies subject to a maximum of 10% of the value of respective delayed supplies. Value of delayed supplies will mean the Gross Value payable to the vendor (Before LD) against such supplies excluding taxes and duties.

b) Where the total items are required for a main equipment and items are interdependent.

Liquidated Damages (LD) for Late Deliveries shall be applicable @0.5% per week or part thereof on total value of Purchase Order subject to maximum of 10% of the total value of Purchase Order. Purchase Order value for this purpose shall be the Total Gross Value payable to the vendor (Before LD) excluding taxes and duties.

"In case of CFR shipment where BHEL accepts the date of inspection as the date of delivery for the purpose of LD, the vendor has to ensure the shipment within 30 days for containerized cargo and 45 days maximum for Break bulk cargo from the date of inspection. Any delay, beyond this period, which is not attributable to BHEL shall be considered for application of LD."

"In case of FOB shipment, vendor has to intimate the readiness of cargo after inspection to BHEL nominated Freight forwarder minimum 15 days in advance for containerized cargo and 30 days in advance for Break bulk cargo before the FOB delivery date. The delay in shipment due to late intimation to BHEL nominated freight forwarder

and not attributable to BHEL will be considered for application of LD".

- c) Bidders are requested to quote the best delivery meeting the delivery requirements. BHEL reserves the right to reject the offers not meeting BHEL's delivery requirement.
- d) Commencement of delivery period shall be reckoned from the date of PO / LOI or any other agreed milestone.
- e) Bidder shall deliver the goods in the manner and schedule agreed under the terms and conditions of Purchase order.
- f) The delivery date for LD purpose will be the Bill of Lading Date/Air way bill.
- g) Payment of Liquidated Damages (LD) shall not in any way relieve the vendor from any of its obligations & liabilities under the contract.

10. PAYMENT TERMS.

- a) BHEL's standard payment term is Payment after Receipt and Acceptance of Material / Item at HEEP, BHEL-Store or at desired destination unless otherwise specified in Special Terms attached to the tender enquiry.
- b) BHEL reserves the right to accept or reject the offer of the bidder who quotes the payment term other than BHEL's standard payment term.
- c) Where the payments are through bank, the documents may be presented for negotiation through BHEL designated banks which will be specified in Purchase order. Documents should be submitted within 5 days of vessel sailing and receipt of OBL from shipping line.
- d) In case BHEL agrees for payment through LC, the same shall be irrevocable, unconfirmed and will be opened 30 days prior to the scheduled delivery and will be valid for a period of 60 days.

Quotations / Bids not in accordance with General Instructions and Standard Terms & Conditions are likely to be ignored.



BHARAT HEAVY ELECTRICALS LIMITED

HEEP-HARIDWAR, UTTARAKHAND (249403)

General Instructions and Standard Terms & Conditions for bidding against Tender Enquiry (GISTC)

For Foreign Bidders (Version June-2021,Rev: 06)

- e) In case of payment after receipt and acceptance of material, 100% payment will be made within 75 days from the date of invoice subject to submission of non-discrepant documents within 15 days of supply as per terms and conditions of Purchase Order. In case any discrepancy found in the documents, BHEL will notify the same to vendor within 7 days of receipt. Vendor has to clear all the discrepancies in one go within 7 days thereafter else the payment may get delayed.

The loading criteria for the different payment terms shall be as under:

Payment Terms	Days of Loading
After Receipt & Acceptance of material within 75 days of supply.	No Loading
Against Delivery at BHEL-Stores Haridwar.	45
Against documents through bank (CAD):	45
Letter of Credit (LC)	120
Usance LC	No Loading if usance period is > 120 Days.
	Loading of days difference i.e difference between 120 days and usance period if the usance period is < 120 days.
Advance	Delivery Period + 120 Days -Advance Payment Days

11. BANK GUARANTEE.

In case the bank guarantees are required to be deposited towards security deposit / performance guarantee or for any other purpose as per the terms of this tender enquiry, such bank guarantees of the requisite value in the denominated currency of the purchase order should be from one of the Indian branch of BHEL consortium banks and the bank guarantee should be in the proforma as prescribed by BHEL. The proforma of bank guarantee and the list of consortium banks are displayed at BHEL website www.bhelhwr.co.in. However, in case the bank guarantee is not from BHEL consortium banks, then the bidder has to get the bank guarantee confirmed from one of the Indian branch of BHEL

consortium banks and the bank charges for such confirmation will be borne by the bidder.

12. GUARANTEE / WARRANTY AND CORRESPONDING REPAIRS / REPLACEMENT OF GOODS.

- a) Goods shall comply with the specifications for material, workmanship and performance. Unless otherwise specified, the warranty shall be for a period of 18 months from the date of receipt. If the delivery is found non-compliant during the warranty period, leading to rejection, the Seller shall arrange free replacement / repair of goods, within one month from the date of intimation or any mutually agreed period. The rejected goods shall be taken away by the Seller at his cost and replaced on Delivered Duty Paid (DDP) (FOR - BHEL Stores / designated destination basis) within such period. In the event of the Seller's failure to comply, Purchaser may take action as appropriate, including Repair / Replenish rejected goods & disposal of rejections, at the risk & cost of the Seller. In case the defects attributable to Seller are detected during processing of the goods at BHEL or at our subcontractor's works, the Seller shall be responsible for free replacement / repair of the goods as required by BHEL.
- b) In case the material is rejected, then date of replacement will be considered as the actual date of delivery.
- c) The bidder shall have to pay 5% incidental charges while taking back supplied material if it is found rejected on receipt. The rejected material shall be sent back only after receipt of replacement / submission of BG/refund of amount paid.

13. QUALITY REQUIREMENT.

Your bid/quotation should have specific confirmation regarding meeting all our quality requirements such as. (i) Test Certificate (TC), (ii) Guarantee Certificate (GC) / Warranty Certificate (WC), (iii) Quality Plan (QP) (if applicable); and (iv) Pre-Dispatch Inspection at your works (if applicable).

Quotations / Bids not in accordance with General Instructions and Standard Terms & Conditions are likely to be ignored.



BHARAT HEAVY ELECTRICALS LIMITED

HEEP-HARIDWAR, UTTARAKHAND (249403)

General Instructions and Standard Terms & Conditions for bidding against Tender Enquiry (GISTC)
For Foreign Bidders (Version June-2021,Rev: 06)

14. VALIDITY.

The quotation should be valid for a minimum period of 90 days effective from the date of opening of tender, unless otherwise specified in the tender enquiry.

15. RIGHT OF ACCEPTANCE.

- a) **BHARAT HEAVY ELECTRICALS LIMITED HARIDWAR** reserves the right to reject any or all the bids / quotations without assigning any reason thereof. BHEL also reserves the right to increase or decrease the tendered quantities. Bidders should be prepared to accept order for reduced quantity without any extra charges.
- b) Any discount / revised offer / bids submitted by a bidder on its own shall be considered, provided it is received on or before the due date and time of offer / bid submission (Part-1). Conditional discounts shall not be considered for evaluation of tenders.
- c) Unsolicited discounts / revised offers / bids given after Part-1 bid opening shall not be accepted. No change in price will be permitted within the validity period asked for in the tender enquiry.
- d) In case of changes in scope and / or technical specification and / or commercial terms & conditions having price implication, techno-commercially acceptable bidders shall be asked by BHEL to submit the impact of such changes on their price bids. In case a bidder opts to submit revised price bid instead of impact called for, then latest price bid shall prevail. However, in both situations, original price bid will be necessarily opened.
- e) The bidder whose bid is technically not accepted will be informed & EMD wherever submitted shall be returned after finalization of contract. EMD shall be forfeited in the event of bidder opting out after tender opening.

- f) BHEL reserves the right to short close the existing Purchase Order / Rate Contract / Work Order or any extension thereof at any stage.

16. TRANSIT INSURANCE.

- a) Transit Insurance will be covered by BHEL under its open Marine Insurance Policy. Seller shall inform dispatch particulars (Purchase Order, RR/GR/BL/ AWB, Invoice value etc.) to Finance department (Store bill Section), BHEL Ranipur Haridwar (Uttarakhand -India) with value of consignment to the Purchaser within 07 days of dispatch for BHEL to arrange insurance coverage in its policy. Failure on the part of seller to inform dispatch particulars will make him liable to pay for any transit damages / losses suffered by the Purchaser.
- b) If Quoted Prices are inclusive of transit insurance, no weightage shall be given while evaluating the bids for Cost of Insurance, being in BHEL Scope.

17. PHYTOSANITARY CERTIFICATE:

- a) As per the Indian Law, all consignments being imported into India by air / sea require a phytosanitary certificate from the country of origin-if articles have been packed with wooden packaging materials. This is mandatory. Please confirm in your offer / dispatch documents that the required phytosanitary certificate will be submitted.
- b) Packaging material means any kind of material of plant origin used for packing which include hay, straw wood shavings, wood chips, saw dust, wood waste, wooden pallets, dunnage mats, wooden packages, coir pith, peat or sphagnum moss etc.

18. RISK PURCHASE.

In case of abnormal delays (beyond the maximum late delivery period as per LD clause) in supplies / defective supplies or non-fulfillment of any other terms and conditions given in Purchase Order, BHEL may cancel the Purchase Order in full or part

Quotations / Bids not in accordance with General Instructions and Standard Terms & Conditions are likely to be ignored.



BHARAT HEAVY ELECTRICALS LIMITED

HEEP-HARIDWAR, UTTARAKHAND (249403)

General Instructions and Standard Terms & Conditions for bidding against Tender Enquiry (GISTC)
For Foreign Bidders (Version June-2021,Rev: 06)

thereof, and may also make the purchase of such material from elsewhere / alternative source at the risk and cost of the supplier. BHEL will take all reasonable steps to get the material from alternate source at optimum cost. If bidder does not agree to the above Risk Purchase Clause, BHEL reserves the right to reject the offer. In case for compelling reasons BHEL accepts the offer without acceptance of this clause by the bidder and in the eventuality of Risk Purchase, appropriate action will be taken as per BHEL extant rules. This will be without prejudice to any other right of BHEL under the contract or under General Law.

19. FORCE MAJEURE CLAUSE.

Notwithstanding any other thing contained anywhere else in the contract or PO (Purchase Order), In case the discharge of obligation under the contract by either party is impeded or made unreasonably onerous, neither party shall be considered in breach of the contract to the extent that performance of their respective obligation is prevented by an event of Force Majeure that arises after the effective date (PO date).

In the above clause, Force Majeure means an event beyond the control of the parties to the contract which prevents a party from complying with any obligation of the contract including but not limited to:

- a) Act of God (Such as but not limited to earthquake, drought, tidal waves, floods etc.).
- b) War (whether war be declared or not), Hostilities Invasion, Act of foreign enemy etc.
- c) Rebellion, revolution, insurrection, civil war etc.
- d) Contamination of Radio Activity from any nuclear fuel or from any other nuclear waste or any other hazardous materials.
- e) Riots, commotions, strike unless restricted to the employees of supplier.
- f) Acts of terrorism.
- g) Other unforeseeable circumstances beyond the control of the parties and which the affected party cannot avoid even by using its best efforts.
- h) Cancellation of contract by customer.

- i) Change in law/ government. Regulation making the performance impossible.
- j) Pandemic or Epidemic.

The party claiming to be affected by force majeure shall notify the other party in writing immediately without delay on the intervention and on the cessation of such circumstances.

Irrespective of any extension of time, if an event of force majeure occurs and its effect continues for more than 180 days the affected party shall have right to cancel the contract.

As soon as reasonably practicable following the date of commencement of a Force Majeure Event, and within a reasonable time following the date of termination of a Force Majeure Event, either Party invoking it shall submit to the other Party reasonable proof of the nature of the Force Majeure Event and of its effect upon the performance of the Party's obligations under this Agreement.

The party shall, and shall ensure that its Subcontractors shall, at all times take all reasonable steps within their respective powers and consistent with Good Operating Practices (but without incurring unreasonable additional costs) to:

- a) Prevent Force Majeure Events affecting the performance of the party's obligations under this Agreement;
- b) mitigate the effect of any Force Majeure Event; and
- c) Comply with its obligations under this Agreement.

If the war like situation has developed in a country where a seller's works is located in the P.O. or there is political instability and Indian Embassy located in that country forbids or advises for not having any business dealing with the sellers located in such zone / region/ country, then BHEL reserves the right to cancel the order.

20. NON-DISCLOSURE AGREEMENT.

All Drawing and Technical Documents relating to the product or it's manufacture submitted by one party to the other, prior or subsequent to the formation of contract, shall remain property of the submitting party. Drawing, technical documents or other

Quotations / Bids not in accordance with General Instructions and Standard Terms & Conditions are likely to be ignored.



BHARAT HEAVY ELECTRICALS LIMITED

HEEP-HARIDWAR, UTTARAKHAND (249403)

General Instructions and Standard Terms & Conditions for bidding against Tender Enquiry (GISTC)
For Foreign Bidders (Version June-2021,Rev: 06)

technical information received by one party, shall not without the consent of the other party, be used for any other purpose than that, for which they were provided. Such technical information shall not without the consent of the submitting party, otherwise be used or copied, reproduced, transmitted or communicated to a third party. Patterns supplied by BHEL will remain BHEL's property which shall be returned by the bidder on demand to BHEL. Bidder shall in no way share or use such intellectual property of BHEL to promote his own business with others or to gain a commercial advantage. BHEL reserves the right to claim damages from the bidder, or take appropriate action as deemed fit against the bidder, for any infringement of the provisions contained herein as available under law or equity.

21. SETTLEMENT OF DISPUTES/ARBITRATION.

Any dispute/difference arising out of or in connection with this contract, including any question regarding its existence, validity or termination, shall be referred to and finally resolved by arbitration under the Arbitration and Conciliation Act, 1996 of India by a Sole Arbitrator to be appointed with mutual consent of the parties. Such Sole Arbitrator shall be either a retired judge of Supreme Court or High Court or District Court of India or some Advocate having practiced in Indian Courts. The seat or place of arbitration shall be New Delhi, India. The language to be used in the arbitration shall be English. The governing law of the contract shall be the substantive law of India. In case the parties fail to agree on the appointment of arbitrator within 2 months of the notice invoking arbitration by one party, then the arbitrator shall be appointed in accordance with the Arbitration and Conciliation Act, 1996 of India.

JURISDICTION: The courts of New Delhi, India, shall have exclusive jurisdiction.

22. INFORMATION TO THE BIDDERS.

- a) Purchase related information is available at our Business-to-Business (B2B) Portal available on our website <https://hwr.bhel.com>. The user ID & password can be obtained by sending a request to concerned purchase executives.

- b) Intimate your change in mail address or communication address or changes, if any, by email to AGM (SDX/MM) giving your bidder Code.
- c) Please resolve your rejections and unexecuted overdue purchase order immediately which are posted at our B2B Portal, which can be visited through our site <https://hwr.bhel.com>.
- d) Copy of this Tender Enquiry is being sent through the post/ Courier / E-mail or by any existing means.
- e) Invoice description and Unit of measurement should be strictly in accordance with Purchase order.
- f) Unit of measurement for dimension and weight should be in metric system only.
- g) The Bidder declares that they will not enter into any illegal or undisclosed agreement or understanding, whether formal or informal with other bidder(s). This applies in particular to prices, specifications, certifications, subsidiary contracts, submission or non-submission of bids or any other actions to restrict competitiveness or to introduce cartelization in the bidding process.
In case, the bidder is found having indulged in above activities, suitable action shall be taken by BHEL as per extant policies/ guidelines.
- h) Supplier must upload digitally signed e-Invoice on B2B portal for processing of Bills.
In other cases, inked signed hard copy of Invoice to be submitted for processing of Bills.

23. MAKE IN INDIA (GOVT-NOTIFICATION).

- A. This tender enquiry shall be governed by notification no. P-45021/2/2017-PP (BE-II) dated 04.06.2020 of government of INDIA and subsequent circulars issued afterwards. Accordingly, the minimum local content, the margin of purchase preference and the procedure for preference to make in INDIA shall be adhered.
- B. The margin of purchase preference shall be 20%.

Quotations / Bids not in accordance with General Instructions and Standard Terms & Conditions are likely to be ignored.



BHARAT HEAVY ELECTRICALS LIMITED

HEEP-HARIDWAR, UTTARAKHAND (249403)

General Instructions and Standard Terms & Conditions for bidding against Tender Enquiry (GISTC)
For Foreign Bidders (Version June-2021,Rev: 06)

- 'Class-I local Supplier' means a supplier or service provider, whose goods, services or works offered for procurement, has local content equal to or more than 50%, as defined under this order.
 - 'Class-II local Supplier' means a supplier or service provider, whose goods, services or works offered for procurement, has local content more than 20% but less than 50%, as defined under this order.
 - 'Non- local Supplier' means a supplier or service provider, whose goods, services or works offered for procurement, has local content less than or equal to 20%, as defined under this order.
- C. Vendor to specifically confirm if they are Class-I or Class-II local supplier or not as per above mentioned notification. Accordingly, the 'Class-I local supplier'/ 'Class-II local Supplier' at the time of tender, bidding or solicitation shall be required to indicate percentage of local content and provide self-certification that the item offered meets the local content requirement for 'Class-I local supplier'/ 'Class-II local Supplier', as the case may be. They shall also give details of the location(s) at which the local value addition is made.
- D. In cases of Procurement for a Value in Excess of Rs. 10 Crores, the 'Class-I local supplier'/ 'Class-II local Supplier' shall be required to provide a Certificate from the Statutory Auditor or Cost Auditor of the Company (in the case of companies) or from a practicing Cost Accountant or practicing Chartered Accountant (in respect of suppliers other than companies) giving the percentage of Local Content.
- E. Requirement of Purchase Preference:
Purchase preference shall be given to 'Class-I local supplier' in procurements undertaken by procuring entities in the manner specified hereunder -
- a. In the procurements of goods or works, which are covered by para 3(b) of mentioned Govt. circular and which are divisible in nature, the 'class-I local supplier' shall get purchase preference over 'Class-II supplier' as well as 'Non-local supplier', as per following procedure:
 - i. Among All qualified bids, the lowest bid will be termed as L1. If L1 is 'Class-I local supplier', the contract for full quantity will be awarded to L1.
 - ii. If L1 bid is not a 'Class-I local supplier', 50% of the order quantity shall be awarded to L1. Thereafter, the lowest bidder among the 'Class-I local supplier' will be invited to match the L1 price for the remaining 50% quantity subject to the class-I local supplier's quoted price falling within the margin of purchase preference, and contract for that quantity shall be awarded to such 'Class-I local supplier' subject to matching the L1 price. In case such lowest eligible 'Class-I local supplier' fails to match the L1 price or accepts less than the offered quantity, the next higher 'Class-I local supplier' within the margin of purchase preference shall be invited to match the L1 price for remaining quantity and so on, and contract shall be awarded accordingly. In case some quantity is still left uncovered on Class-I local supplier, then such balance quantity may also be ordered on the L1 bidder".
 - b. In the procurements of goods or works, which are covered by para 3(b) of mentioned Govt. circular and which are not divisible in nature, and in procurement of services where the bid is evaluated on price alone, the 'class-I local supplier' shall get purchase preference over 'Class-II supplier' as well as 'Non-local supplier', as per following procedure:
 - i. Among all qualified bids, the lowest bid will be termed as L1. If L1 is 'Class-I local supplier', the contract will be awarded to L1.
 - ii. If L1 is not 'Class-I local supplier', the lowest bidder among the 'Class-I local supplier', will be invited to match the L1 price subject to Class-I local supplier's quoted price falling within the margin of purchase preference, and the contract shall be awarded to such 'Class-I local supplier' subject to matching the L1 price.
 - iii. In case such lowest eligible 'Class-I local supplier', fails to match the L1 price, the 'Class-I local supplier' with the next higher bid within the margin of purchase preference

Quotations / Bids not in accordance with General Instructions and Standard Terms & Conditions are likely to be ignored.



BHARAT HEAVY ELECTRICALS LIMITED

HEEP-HARIDWAR, UTTARAKHAND (249403)

General Instructions and Standard Terms & Conditions for bidding against Tender Enquiry (GISTC)
For Foreign Bidders (Version June-2021,Rev: 06)

shall be invited to match the L1 price and so on and contract shall be awarded accordingly. In case none of the 'Class-I local supplier' within the margin of purchase preference matches the L1 prices, the contract may be awarded to the L1 bidder.

- c. 'Class-II local supplier' will not get purchase preference in any procurement, undertaken by procuring entities.
- F. For this procurement, the local content to categorize a supplier as a Class-I local supplier/ Class-II local supplier/ Non-local supplier and purchase preference to Class-I local supplier, is as defined in Public Procurement (Preference to Make in India), Order 2017 dated 04.06.2020 issued by DPIIT. In case of subsequent orders issued by nodal ministry, changing the definition of local content for the items of the NIT, the same shall be applicable even if issued after issue of this NIT, but before opening of Part-II bids against this NIT.
- G. Procurements where estimated value to be procured is less than Rs. 5 lakhs shall be exempted from GOI order No. P-45021/2/2017-PP (BE-II) dated 04.06.2020.
- H. For procurement of Goods & Services which are divisible in nature, following shall be operated for **MSE bidders** under Public procurement Policy for the Micro and Small Enterprises (MSEs) Amendment Order, 2019, Ref. No. AA: SSP: MSE: Amndt, dtd. 30.11.2018, Circular No. 44 of 2018-19:-
- a. If L1 bid is not from "Class-I local Supplier" and price quoted by MSE bidder falls within the margin of Purchase preference (L1+15% for MSEs), then 25 % of total order quantity of respective item (rounded off to nearest number) shall be awarded to MSE bidder, subject to MSE bidder matching the L1 Price. Out of Remaining 75% quantity, distribution shall be operated as per below sub-clause (2) –
- b. If "Class- I Local Supplier" (Next to L1, other than MSE) quoted price falling within the Margin of Purchase Preference, and "Class-I local supplier" matches the L1 price, then 50% of remaining Quantity (after allocation of 25% to MSE) i.e. 37.5% shall be awarded to local supplier and 37.5% shall be awarded to foreign bidder.

Note: L1 Price refers to lowest evaluated / landed cost to Company.

For Further details, please refer GOI order no. P-45021 / 2 / 2017 - PP (BE-II) dated 04.06.2020.

24. RESTRICTIONS UNDER RULE 144(XI) OF THE GENERAL FINANCIAL RULES (GFRs), 2017

All provisions of Order No. F.No.6/18/2019-PPD of Department of Expenditure (DoE) shall be applicable for this tender enquiry (Order copy is available at <https://doe.gov.in/procurement-policy-divisions>). Accordingly, any bidder from a country which shares a land border with India (except the countries to which the Govt. of India has extended lines of credit or in which the Govt. of India is engaged in development projects for which list is available at <https://www.mea.gov.in/>) will be eligible to bid in this tender only if the bidder is registered with the Competent Authority as specified in Annex I of the said Order of DoE.

Updated list of the countries to which lines of credit have been extended or in which development projects are undertaken are available on the Ministry of External affairs website (<https://www.mea.gov.in/>)

For the purpose of this order, definition of Bidder from a country which shares a land border with India shall be same as defined in the Annex III of the said order.

Registration with the competent authority as stipulated in the said order is responsibility of bidder. Bidder has to submit a certificate certifying following along with offer:

"I have read the clause regarding restrictions on procurement from a bidder of a country which shares a land border with India; I certify that bidder (.... Name of Bidder) is not from such a country or, if from such a country, has been registered with the Competent Authority. I hereby certify that bidder (....Name of bidder) fulfils all requirements in this regard and is eligible to be considered"

If the bidder is from such country which shares a land border with India evidence of valid registration by the Competent Authority shall also be attached along with offer."

Quotations / Bids not in accordance with General Instructions and Standard Terms & Conditions are likely to be ignored.



BHARAT HEAVY ELECTRICALS LIMITED

HEEP-HARIDWAR, UTTARAKHAND (249403)

General Instructions and Standard Terms & Conditions for bidding against Tender Enquiry (GISTC)
For Foreign Bidders (Version June-2021,Rev: 06)

25. NOTE.

- a) Special conditions of enquiry, if enclosed by BHEL, will supersede the respective standard/general terms of enquiry.
- b) Any other Standard terms and Conditions of the bidder attached/referred against the tender enquiry will be treated as null and void ab initio.
- c) In order to protect the commercial interests of BHEL, it becomes necessary to take action against suppliers / contractors by way of suspension of business dealings, who either fail to perform or are in default without any reasonable cause, cause loss of business / money / reputation, indulged in malpractices, cheating, bribery, fraud or any other misconducts or formation of cartel so as to influence the bidding process or influence the price etc. Guide- lines for Suspension of Business Dealings with Suppliers / Contractors shall prevail over which is available at BHEL website <http://www.bhel.com>
- d) The bidder along with its associate / collaborators / sub-contractors / sub-vendors / consultants / service providers shall strictly adhere to BHEL Fraud Prevention Policy displayed on BHEL website <http://www.bhel.com> and shall immediately bring to the notice of BHEL-Management about any fraud or suspected fraud as soon as it comes to their notice.
- e) "BHEL shall recover the amount of compensation paid to victim(s) by BHEL towards loss of life / permanent disability due to an accident which is attributable to the negligence of contractor, agency or firm or any of its employees as detailed below;
1. **Victim:** Any person who suffers permanent disablement or dies in an accident as defined below.
 2. **Accident:** Any death or permanent disability resulting solely and directly from any unintended and unforeseen injurious occurrence caused during the manufacturing / operation and works incidental thereto at BHEL factories/ **offices and precincts** thereof , project execution , erection and commissioning, services, repairs and maintenance, trouble

shooting, serving , overhaul, renovation and retrofitting , trial operation, performance guarantee testing undertaken by the company or during any works / during working at BHEL Units/ Offices/ townships and premises/ project sites.

3. Compensation in respect of each of the victims:

- (i) In the event of death or **permanent disability** resulting from **Loss of both limbs:** Rs. 10,00,000/- (Rs. Ten Lakh).
- (ii) In the event of **other permanent disability:** Rs. 7,00,000/- (Rs. Seven Lakh).

Permanent Disablement: A disablement that is classified as a permanent total disablement under the proviso to Section 2(I) of the Employees Compensation Act, 1923."

f) The bidder shall be in compliance with applicable laws, rules and regulations throughout the terms of the contract for conducting its business generally and to perform its obligations under this contract.

Quotations / Bids not in accordance with General Instructions and Standard Terms & Conditions are likely to be ignored.

[Validate](#)[Print](#)[Help](#)[Item Wise BoQ](#)

Tender Inviting Authority: PPX-BOI, HEEP, BHEL, Haridwar

Name of Work: Procurement of Variable Load Spring Cages for Budge-Budge project

Contract No: B/4011/2022/0959/V1

Name of the Bidder/ Bidding Firm / Company :

PRICE SCHEDULE

(This BOQ template must not be modified/replaced by the bidder and the same should be uploaded after filling the relevant columns, else the bidder is liable to be rejected for this tender. Bidders are allowed to enter the Bidder Name and Values only)

Note:

1. Evaluation will be done on basis of Total Landed Cost to BHEL upto Project site.
2. Indigenous bidders to quote their FOR prices inclusive of GST. Any other tax shall be taken inclusive in quoted prices.
3. For Foreign bidders, Custom Duty and Exchange rate as applicable on the date of Part-1 bid opening date and Inland Freight as per GISTC will be considered extra for evaluation purpose.
4. For Foreign bidders, all taxes in the country of origin shall be taken inclusive in the quoted prices.

NUMBER #	TEXT #	TEXT #	NUMBER #	TEXT #	TEXT #	NUMBER #	NUMBER #	TEXT #
Sl. No.	Item Description	Item Code / Make	Quantity	Units	Quoted Currency in INR / Other Currency	UNIT PRICE In Figures To be entered by the Bidder. Indian bidder to Quote on FOR site including GST basis. Foreign bidder to Quote on CFR Mumbai basis.	TOTAL AMOUNT, It will be converted based on column L value in Rs. P	TOTAL AMOUNT In Words
1	2	3	4	5	12	13	53	55
1	Supply portion							
1.1	VARIABLE LOAD SPRING CAGES AS PER DOC. NO. 313177A2550, DOC. NO. 413177A2501 AND ST34004 REV. 08	W90313133468	1.0000	NUMBER	INR		0.0000	INR Zero Only
Total in Figures							0.0000	Zero Only

MANUFACTURER'S NAME AND ADDRESS		STANDARD QUALITY PLAN					TO BE FILLED BY BHEL		TO BE FILLED BY BHEL			
BHEL	VENDOR'S NAME	ITEM	VARIABLE LOAD SPING CAGES		QP NO.	QA/BI/QP/011						
				DATED & REV	31.07.2018 03							
		DRG. NO.	313177A2550 & 413177A2501									
		SPEC.	ST 34004									
REV	AS PER PO					Page 1 of 2						
SL. NO.	COMPONENT & OPERATIONS	CHARACTERISTICS	CLASS	TYPE OF CHECK	QUANTUM OF CHECK	REFERENCE DOCUMENT	ACCEPTANCE NORMS	FORMAT OF RECORDS		AGENCY		REMARKS
1	2	3	4	5	6	7	8	9	D	10	11	

1. RAW MATERIAL

1.1	CS BAR STOCK PLATE CASING PIPE	CHEMICAL COMPOSITION MECHANICAL PROPERTY	MAJOR	CHEMICAL MECHANICAL	1/HEAT	ORDERING SPECIFICATION/ BHEL APPD DWG	ORDERING SPECIFICATION/ BHEL APPD DWG	TC	✓	P	V		
1.2	TURN BUCKLE (FORGED COMPONENT)	CHEMICAL COMPOSITION MECHANICAL PROPERTY	MAJOR	CHEMICAL MECHANICAL	1/HEAT	ORDERING SPECIFICATION/ BHEL APPD DWG	ORDERING SPECIFICATION/ BHEL APPD DWG	TC	✓	P	V		
		DIMENSIONAL & VISUAL	MAJOR	MEASURE	100%	ORDERING SPECIFICATION/ BHEL APPD DWG	ORDERING SPECIFICATION/ BHEL APPD DWG	TC	✓	P	V		
		PROOF LOAD	MAJOR	LOAD TEST	20% OR MIN 2 PIECE	ORDERING SPECIFICATION/ BHEL APPD DWG	ORDERING SPECIFICATION/ BHEL APPD DWG	TC	✓	P	V		In case of defect, whole lot to be tested
		SURFACE DEFECT	MAJOR	DPT	20% OR MIN 2 PIECE	ORDERING SPECIFICATION/ BHEL APPD DWG	NO LINEAR INDICATION	TC	✓	P	V		In case of defect, whole lot to be tested
1.3	SPRING	CHEMICAL COMPOSITION	MAJOR	CHEMICAL	1/ HEAT	ORDERING SPECIFICATION/ BHEL APPD DWG	ORDERING SPECIFICATION/ BHEL APPD DWG	TC	✓	P	V		
		DIMENSIONAL & VISUAL	MAJOR	MEASURE	1/HEAT	ORDERING SPECIFICATION/ BHEL APPD DWG	ORDERING SPECIFICATION/ BHEL APPD DWG	TC	✓	P	V		
		SCRAGGING/ COMPRESSION TO BLOCK LENGTH	MAJOR	MEASURE	100%	ORDERING SPECIFICATION/ IS:7906 PART-II	ORDERING SPECIFICATION/ IS:7906 PART-II	TC	✓	P	W *		* 10%
		STATIC LOAD TESTING	MAJOR	LOAD TEST	100%	ORDERING SPECIFICATION/ IS:7906 PART-II	ORDERING SPECIFICATION/ IS:7906 PART-II	TC	✓	P	W *		* 10%

2. IN-PROCESS INSPECTION

2.1	MECHANICAL ITEMS	DIMENSIONAL & VISUAL	MAJOR	MEASURE	100%	BHEL APPD DWG	BHEL APPD DWG	IR	✓	P	V		
		WELDING QUALITY	MAJOR	DPT	100%	ASME-SEC-V	ASME-SEC-VIII	IR	✓	P	V		NOTE 1

MANUFACTURER/S UBCONTRACTOR		LEGEND: ! RECORDS IDENTIFIED WITH 'TICK' SHALL BE ESSENTIALLY INCLUDED BY CONTRACTOR IN QA DOCUMENTATION. M: MANUFACTURER / SUBCONTRACTOR B: BHEL / NOM. INSPECTION AGENCY N: CUSTOMER INDICATE 'P' PERFORM 'W' WITNESS AND 'V' VERIFICATION	FOR CUSTOMER USE	APPROVED BY		Digitally signed by Manindra Kumar Date: 2022.07.27 10:11:49 +05'30'
		ALL 'W' INDICATED IN COLUMN 'N' SHALL BE 'CHP' OF CUSTOMER				

MANUFACTURER'S NAME AND ADDRESS		STANDARD QUALITY PLAN					TO BE FILLED BY BHEL		TO BE FILLED BY BHEL			
BHEL	VENDOR'S NAME	ITEM	VARIABLE LOAD SPING CAGES		QP NO.	QA/BI/QP/011						
				DATED & REV	31.07.2018 03							
		DRG. NO.	313177A2550 & 413177A2501									
		SPEC.	ST 34004									
REV	AS PER PO					Page 2 of 2						
SL. NO.	COMPONENT & OPERATIONS	CHARACTERISTICS	CLASS	TYPE OF CHECK	QUANTUM OF CHECK	REFERENCE DOCUMENT	ACCEPTANCE NORMS	FORMAT OF RECORDS		AGENCY		REMARKS
1	2	3	4	5	6	7	8	9	D	10		11

2.2	ASSEMBLY	FITMENT & OVERALL DIMENSIONS	MAJOR	MEASURE	100%	BHEL APPD DWG	BHEL APPD DWG	IR	✓	P	V		
3. FINAL INSPECTION													
3.1	ASSEMBLY	DIMENSIONS	MAJOR	MEASURE	100%	BHEL APPD DWG	BHEL APPD DWG	TC	✓	P	W*		* 10%
		LOAD-TRAVEL TEST/ SPRING RATE/ PRESET LOAD	CRITICAL	MEASURE	100%	BHEL APPD DWG	BHEL APPD DWG	TC	✓	P	W*		* 10%
		IDENTIFICATION, PAINTING, PACKING & DESPATCH CLEARANCE	MAJOR	VERIFY DRY FILM THICKNESS	100%	ORDERING SPECIFICATION/ PAINTING SCHEDULE DOCUMENT	ORDERING SPECIFICATION/ PAINTING SCHEDULE DOCUMENT	TC	✓	P	V		FOR PAINTING, TAKE CARE OF BHEL DOC NO:- 413177A2501, Rev: 00

NOTE:1 - Welding to be done by qualified welder and approved welding procedures as per ASME IX WPS.

		LEGEND:	FOR CUSTOMER USE
MANUFACTURER/S UBCONTRACTOR		! RECORDS IDENTIFIED WITH 'TICK' SHALL BE ESSENTIALLY INCLUDED BY CONTRACTOR IN QA DOCUMENTATION.	APPROVED BY
		M: MANUFACTURER / SUBCONTRACTOR B: BHEL / NOM. INSPECTION AGENCY N: CUSTOMER INDICATE 'P' PERFORM 'W' WITNESS AND 'V' VERIFICATION	
		ALL 'W' INDICATED IN COLUMN 'N' SHALL BE 'CHP' OF CUSTOMER	Digitally signed by Manindra Kumar Date: 2022.07.27 10:12:03 +05'30'

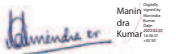
BHEL, B.A. Head Office