

TENDER DETAILS

ENQUIRY No.	1402200014	ENQUIRY DATE	10.10.2022
DESCRIPTION	Supply of Flanges in the specification Hastelloy C276 (UNS No. N10276)	DUE DATE	08.11.2022

Item Sl. No.	Description	Material Code	Unit	Quantity
10	C276 FLANGE 2" (50NB) FLAT FACED AS PER TECHNICAL SPECIFICATION – FP:FLN:02 REV 00	920370180000	Numbers	158
20	C276 FLANGE 3" (80NB) FLAT FACED AS PER TECHNICAL SPECIFICATION – FP:FLN:02 REV 00	920370190000	Numbers	94

ATTACHMENTS:

Annexure A - Enquiry Terms and Conditions
Technical Specification
Technical Pre-Qualification Requirement - PQR
Annexure C - Vendor details

"LD clause has to be confirmed without fail."

The bidder along with its associate / collaborators / sub-contractors / sub-vendors / consultants /service providers shall strictly adhere to BHEL fraud prevention policy displayed on BHEL website <http://www.bhel.com> and shall immediately bring to the notice of BHEL Management about any fraud or suspected fraud as soon as it comes to their notice.

BHARAT HEAVY ELECTRICALS LIMITED
MM / RM / PURCHASE / C&F
BHEL / TRICHY-620 014.

ANNEXURE-A Rev 01
ENQ.No.1402200014

Dt.06-10-2022

Enquiry Terms & Conditions for Supply of Haste Alloy C276 (UNS No. N10276) Flanges

Note: This Annexure has to be mandatorily filled & signed by the manufacturer (or) mill and submitted along with Technical bid.

Any deviation to the below mentioned terms shall be stated specifically in the comments column for each term and also in case of acceptance to our terms, it will be construed that the whole term is understood and agreed in totality without any deviation. (If otherwise mentioned).

Sl No	BHEL Requirements	Supplier Comments
01	<p>Material Specification:</p> <p>Supply of Haste Alloy C276 (UNS No. N10276) Flanges shall be made strictly as per Technical Specifications, Drawings and Technical Pre-Qualification Requirement as mentioned in the enquiry.</p>	
02	<p><u>Technical Pre-Qualification Requirement:</u></p> <p>1. Bidder must have the experience of supplying C276 (UNS N10276) spec material/similar spec special material to any of the Govt./PSUs/Private Companies.</p> <p>Following supporting documents to be submitted as a proof:</p> <p>a. Unpriced PO copies.</p> <p>b. Proof of supply (such as Invoice / LWB copies)</p> <p>c. Test certificate of previously executed purchase order of C 276 (UNS N10276) material /similar material.</p> <p>2. Bidder should confirm that supply of C276 (UNS N10276) Flanges shall be as per Technical Specification: FP: FLN: 02 Rev 00.</p> <p>4. Offers of bidders who have quoted for all the variants of Flanges will only be considered, since evaluation will be done as a single package.</p>	
03	<p><u>Offer Submission:</u></p> <p>a) This Tender is hosted in EPS portal & offer to be submitted through EPS portal only. You are requested to submit your 2 parts offer before due date & time of the enquiry through NIC (https://eprocurebhel.co.in) only.</p> <p>b) Offer is to be submitted in TWO part bids system (Technical bid + Price bid) in the E-Procurement NIC PORTAL (https://eprocurebhel.co.in) ONLY.</p> <p>c) Scanned copy of the filled Annexure-A, Tender documents etc., shall be uploaded in the EPS portal.</p> <p>d) At its option, BHEL may consider extending the due date/s for the tender openings. Sufficient notice would be given by BHEL for such extensions and it will be published as corrigendum in following websites, https://eprocurebhel.co.in http://www.bhel.com/tender/</p> <p>e) Acceptance of offer will be subject to existing customer approval.</p> <p>f) Import Suppliers shall indicate the quoted currency.</p>	
04	<p><u>Reverse Auction</u></p> <p>BHEL shall be resorting to Reverse Auction (RA) (Guidelines as available on www.bhel.com) for this tender. RA shall be conducted among the techno-commercially qualified bidders. Price bids of all techno-commercially qualified bidders shall be opened and same shall be considered for RA. In case any bidder(s) do(es) not participate in online Reverse Auction, their sealed envelope price bid along with applicable loading, if any, shall be considered for ranking.</p>	
05	<p><u>Authorization for participation in EPS portal through DSC: E-Tender. Participation requirements:</u></p>	

	<p>Either Principal or authorized agent shall register their Digital Signature Certificate (DSC) (Class 3- SHA2- 2048 BIT- SIGNING & ENCRYPTION). Suppliers are advised to go through the FAQ available in the web portal (https://eprocurebhel.co.in). DSC shall be registered for the authorized person and all transaction done using that DSC against our tenders shall be taken as valid communication and shall be binding on principal/agent and is valid legally.</p> <p>For foreign Principal</p> <p>In case of Principal (being foreigner), they may apply for DSC through Indian embassy at their country and can register with us for participating in E-tenders. Details of the applicable procedure is available in the webpage http://www.cca.gov.in/cca/.</p> <p>For Indian agent</p> <p>In case of agents participating/registering their DSC (of authorized person), it will be at the sole authorization of principal to their agents to participate on their behalf and all transactions done using that DSC against our tenders shall be known as valid communication and shall binding on principal and is legally valid.</p>	
06	<p>Validity:</p> <p>The offers shall be kept open for acceptance for 90 days from the date of Tender opening. Once the tenders are submitted, rates cannot be changed on any grounds.</p>	
07	<p>Delivery:</p> <p>The offer shall clearly indicate delivery period in fixed number of weeks/Months from the date of Purchase Order.</p>	
08	<p>Goods and Service Tax (GST)</p> <p>Indigenous suppliers:</p> <ul style="list-style-type: none"> • Response to Tenders for Indigenous supplier will be entertained only if the vendor has a valid GST registration Number (GSTIN) which should be clearly mentioned in the offer. If the dealer is exempted from GST registration, a declaration with due supporting documents need to be furnished for considering the offer. Dealers under composition scheme should declare that he is a composition dealer supported by the screen shot taken from GSTN portal. The unregistered dealer as well as the composition dealer has to submit an undertaking stating that they will not claim GST during the execution of the contract even if their status under GST changes to regular tax payer. The dealer has to submit necessary documents if there is any change in status under GST. • Supplier shall mention their GSTIN in all their invoices (incl. credit Notes, Debit Notes) and invoices shall be in the format as specified/prescribed under GST laws. Invoices shall necessarily contain Invoice number (in case of multiple numbering system is being followed for billing like SAP invoice no, commercial invoice no etc., then the Invoice No. which is linked/uploaded in GSTN network shall be clearly indicated), Billed to party (with GSTIN) & Shipped to party details, item description as per PO, Quantity, Rate, Value, applicable taxes with nomenclature (like IGST, SGST, CGST & UTGST) separately, HSN/ SAC Code, Place of Supply etc. Wherever E-Invoice is applicable, the tax invoice/ CN / DN submitted by the vendor must contain the QR code generated in E-Invoice Portal & IRN. • All invoices shall bear the HSN Code for each item separately (Harmonized System of Nomenclature)/ SAC code (Services Accounting Code). • Invoices will be processed only upon completion of statutory requirement and further subject to following: <ul style="list-style-type: none"> Vendor declaring such invoice in their GSTR-1 Return/ IFF Receipt of Goods or Services and Tax invoice by BHEL • As the continuous uploading of tax invoices in GSTN portal (in GSTR-1/ IFF) is available for all (i.e. both Small & Large) tax payers, all invoices raised on BHEL may be uploaded immediately in GST portal on dispatch of material /rendering of services. The supplier shall ensure availability of Invoice in GSTN portal before submission of invoice to BHEL. Invoices will be admitted by BHEL only if the invoices are available in GSTN portal (in BHEL's GSTR-2A/ GSTR-2B). • In case of discrepancy in the data uploaded by the supplier in the GSTN portal or in case of any shortages or rejection in the supply, then BHEL will not be able to avail the tax credit and will notify the supplier of the same. Supplier has to rectify the data discrepancy in the GSTN portal or issue credit note or debit note (details also to be uploaded in GSTN portal) for the shortages or rejections in the supplies or additional claims, within the calendar month informed by BHEL. 	

	<ul style="list-style-type: none"> In cases where invoice details have been uploaded by the vendor but failed to remit the GST amount to GST Department (Form PMT-08 or Form GST RET-01 to be submitted) within stipulated time, then GST paid on the invoices pertaining to the month for which GST return not filed by the vendor will be recovered from the vendor along with the applicable interest (currently 24% p.a) and all subsequent bills of the vendor will not be processed till filing of the GST return by the vendor. The offer will be evaluated on total landed cost to BHEL, Trichy as below, Total landed cost = FOR Trichy + applicable taxes + commercial loading as applicable - applicable tax credits Note: Transit insurance in the scope of supplier only. In case GST credit is denied to BHEL due to non-receipt or delayed receipt of goods and/ or tax invoice or expiry of timeline prescribed in GST law for availing such ITC, or any other reasons not attributable to BHEL, GST amount claimed in the invoice shall be disallowed to the vendor. Where any GST liability arising on BHEL under Reverse Charge (RCM), the vendor has to submit the invoices to BHEL well within the timeline prescribed in GST Law, to enable BHEL to discharge the GST liability. If there is a delay in submission of invoice by the vendor resulting in delayed payment of GST by BHEL along with Interest, then such Interest payable or paid shall be recovered from the vendor. GST TDS will be deducted as per Section 51 of CGST Act 2017 and in line with Notification 50/2018 – Central Tax dated 13.09.2018. GST TDS certificate will be generated in GSTN portal subsequent to vendor accepting the TDS deduction in the GSTN portal & the vendor can directly download the Certificate from the GSTN Portal. <p>Import Suppliers: Supplier shall mention the HSN code of each item quoted by them in the offer. The HSN shall be mentioned in the Invoice also for each item without fail.</p> <p>Since GST is implemented, the taxes & duties will prevail as per the government notification/ guidelines. Our Provisional GST registration no. is 33AAACB4146P2ZL. However, it will be mandatory to confirm from BHEL for this mentioned GST no. Suppliers may quote their GST no with valid proof in the quotation. Also before quoting of tender it is suggested to consider all the factors in line with GST guidelines for input tax credit to arrive ranking of quoted suppliers.</p>	
09	<p>Indigenous vendors – Terms of delivery:</p> <ul style="list-style-type: none"> Bidders should submit their offer on FOR Destination -BHEL Stores, Trichy basis. The quote should be inclusive of all charges, including testing, packing & forwarding, inspection, Insurance etc. (Ex-Works offers will not be considered). The soft copies of the Invoice, LR copy & Test certificates shall be forwarded to BHEL immediately after dispatch. 	
10	<p>IMPORT Vendors - Terms of Delivery:</p> <ol style="list-style-type: none"> Import vendors to submit offers on CFR (Cost & Freight), Chennai port (LILO – Liner in Liner Out) basis. Port of loading should be indicated without fail. Port of discharge should be Chennai. The preferred shipment mode “Containerized Cargo or Break Bulk” shall be specified clearly in the offer. <p>FOR CFR INCO TERMS – CONTAINERIZED CARGO</p> <ol style="list-style-type: none"> For CFR terms, moved through CONTAINERS (Suppliers should clearly specify this in their offer) it would be presumed by BHEL that the freight charges quoted is on LILO (LINER IN LINER OUT) basis including extra charges, if any, like Container Imbalance Charges, Trade Imbalance charges or any other charges payable to the Liner. No other charges other than the quoted Freight rate will be paid by BHEL excepting applicable Terminal Handling Charges, Container cleaning Charges, DO charges to Shipping Liner at Discharge Port. 14 FREE DAYS FOR Container detention shall be provided. In case of shipment through Containers on CFR basis, the BL should bear the endorsement that “14 free days for Container Detention is applicable”. <p>BREAKBULK CARGO:</p> <ol style="list-style-type: none"> For CFR terms, moved through BREAK BULK BASIS (Suppliers should clearly specify this in their offer) it would be presumed by BHEL that the freight charges quoted is on LILO (LINER IN LINER OUT) basis. The materials will be Custom cleared from Port itself. 	

INFORMATION TO IMPORT SUPPLIERS:

- a) Indian Customs imposed a penalty on late filing of Bill of Entries (Air/Sea Shipments) by the importer. Bill of Entry is Required to be Filed Latest by the End of Day Preceding the Day (including Holidays) of Arrival of the Vessel for sea shipments and by the end of same day on arrival of air shipment. Penalty for not filing Bill of Entry within the specified time period is Rs.5000/- per day (for Initial 03 days) & Rs.10000/- per day (thereafter).
- b) The vendor should furnish the Non-Negotiable Documents (Air Way Bill/Bill of Lading, Commercial Invoice, Packing List, and Certificate of Origin) either by email or post/courier to BHEL well before the landing of cargo at final port of discharge.
- c) Vendor will be held responsible for the penalty arises against the late filing of Bill Of entry due to:
 - Non availability of Non-Negotiable Documents (NNDs) before the cargo arrival
 - Discrepancy in documents
 - Short landing of Consignments (For shipments on CFR/CPT/CIF/CIP – Chennai Port)
- d) All the shipments for the contracts (POs) finalized on CFR -Chennai Port basis
 - (i) Delivery Orders involving multiple agencies like liners/freight forwarders are not allowed. There must be a single agency office at the final discharge Port (Chennai) for issuing the Delivery Order to BHEL.
 - (ii) The detention/demurrage charges arising due to the nomination of containers under single BL to different/ multiple CFS by the liner will be deducted from Vendor's bills only.
 - (iii) The detention/demurrage charges arise due to the delay in collection of Delivery Orders from multiple agencies of liner/freight forwarder also whose offices are not at available Chennai, the same amount will be deducted from Vendor's bills only.
 - (iv) Apart from the normal charges like Terminal Handling Charges, Container cleaning Charges, Delivery Order Charges at final port of discharge no other charges will be borne by BHEL.
 - (v) The liner/freight forwarders should be properly communicated by the Vendor for not to claim such charges for issuing Delivery Order. If the liner/freight forwarder claims such charges in their invoices, the same amount will be deducted from the Vendor bills without any prior intimation in order to avoid the delay in Customs clearance. The likely additional/hidden costs or charges are:
 - a. CIC - Container Imbalance Charges/Surcharges
 - b. EIC - Equipment Imbalance Charge/Surcharges
 - c. CAF - Container/Currency Adjustment Factor
 - d. BAF - Bunker adjustment Factor
 - e. RDS - Rupee Depreciation Surcharge
 - f. CDS - Currency Depreciation Surcharge
 - g. PCS - Port Congestion Surcharge
 - h. LSS - Low Sulphur Surcharge
 - i. Devanning Charges

11 Transport Conditions for Import:

The Original Documents (Bill of Lading, Invoice, Packing List, Certificate of Origin & Test Certificate) shall reach BHEL well in advance before the vessel arrival. The soft copies of the above shall be forwarded to BHEL immediately after shipment.

- a) 14 FREE DAYS for Container detention at final port of destination shall be provided and the same to be endorsed in the Bill of Lading. If there is no free day or less than 14 free days provided by the supplier, the actual cost incurred towards detention charges due to non-availability of above said free days will be recovered from the supplier Invoice.
- b) In the event of delayed submission of documents/ non-submission of documents by the supplier as per the mutually agreed terms, an amount up to 5% of the invoice value will be retained towards detention/ demurrage & other charges and the difference if any between actual charges and recovery will be settled separately through supplementary invoice.
- c) In such cases, the Supplier shall authorize the Steamer / Shipping agent / transporter to freely release the consignment to BHEL by providing a "Surrender Bill of Lading".
- d) Otherwise, No-objection Certificate shall be issued to the Liner, authorizing BHEL to get the Delivery Order without producing the Original Bill of Lading.
- e) This is required to ensure avoidance of detention/ demurrage at Chennai Sea-port that may arise in case of delayed presentation of documents by the Seller.

12	<p>Acceptance of materials supplied:</p> <ol style="list-style-type: none"> The supply shall strictly as per the specifications in the tender /purchase order. Delivery of the ordered items as per the delivery terms in the Purchase Order does not automatically constitute acceptance of the delivered items. The acceptance or otherwise of the delivered items will be separately communicated to the supplier by BHEL either through B2B portal or through e mail within 120 days' o from the delivery of items or delivery of the required test certificates /other documents whichever is later. In case of rejection of the delivered items, either part or full, the vendor shall replace the rejected items as per the specification in the Purchase order/tender at their cost within specified days/months of communication of rejection to the supplier. In case of rejection of the delivered items, either part or full, if the supplier fails to replace the rejected items within the specified days/months of communication of the rejection, the same shall be treated as failure to execute the contract and actions as per the Guidelines for Suspension of Business Dealings with Suppliers /Contractors available in the webpage: http://www.bhel.com/vender_registration/vender.php. would be taken against such supplier. 	
13	<p>Payment terms:</p> <p>Indigenous: BHEL Payment term is 100% direct EFT payment after 90 days from the date of receipt and acceptance of materials. Payment for MSE Indigenous vendors will be as per MSMED Act, 2006</p> <ol style="list-style-type: none"> Micro & Small Suppliers – within 45 days from the date of receipt and acceptance of materials. Medium Suppliers – 60 days from the date of receipt and acceptance of materials <p>Import: BHEL Payment term is 100% payment on CAD basis after 90 days from the date of receipt of documents, specified in PO, at BHEL bank. Respective bank charges to respective account.</p> <p>If supplier insists for LC, only Usance LC with 120 days' credit will be opened one month prior to material readiness, further loading @ 1.5% on the offered value will be considered. Hence supplier shall intimate the material readiness accordingly along with MTC copies for opening of L.C. LC validity period will be 90 days and for any extension, applicable charges will be to supplier's account.</p> <p>New Suppliers: For new suppliers not registered with BHEL, Trichy for the product, Payment shall be made 90 days after receipt and acceptance of materials. In case of foreign supplier, first lot of mutually agreed quantity shall be supplied with payment as CAD basis after 90 days from the date of receipt & acceptance of material. If insisted for LC, after acceptance of first lot only, Usance LC with 120 days' credit will be opened one month prior to material readiness.</p>	
14	<p>Liquidated Damage (Indigenous & Imports):</p> <ol style="list-style-type: none"> Time is the essence of the contract. The ordered items shall be delivered as per the delivery period mentioned in the Purchase Order. In case the supplier supplies the ordered items beyond the delivery period specified, Liquidated Damages -LD - as detailed below shall be will be levied from the supplier without prejudice to any other relief /compensation available to BHEL, Tiruchirappalli under any other condition of the contract/applicable legal provisions. LD shall be 0.5% of the undelivered portion per week or part thereof subject to a maximum of 10% of the total order value. Any deviation from the above LD clause, loading will be applied to the extent to which it is not agreed by the bidder (at offered value). <p>Indigenous: For "FOR Delivery terms", Lorry way bill date will be taken for LD calculation for cases where E way bill is not mandatory. Wherever E Way Bill is involved, the date of commencement of movement of vehicle as reflected in E way Bill [the 'Valid from' date in the E way Bill] will be taken for LD calculation.</p> <p>Import: For CFR terms, BL date will be considered for LD calculation.</p>	
15	<p>Risk Purchase clause:</p> <ol style="list-style-type: none"> In the event of any successful Tenderer's failure to fulfil any of the tender / Contract obligations including supply of whole or any part of the ordered items as per Contract / Agreement, BHEL has the right to terminate the contract and purchase from elsewhere ,at the risk and cost of the defaulted supplier, either the whole of the goods or any part which the supplier has failed to deliver or dispatch within the time stipulated in the contract or if the same were not available, the best and nearest available substitute thereof. The supplier shall be liable for the additional expenditure/difference in Cost, if any, including consequential losses which BHEL may sustain by reason of risk purchase in addition to the applicable LD as per the Purchase order/contract. 	

	<p>b) The decision of BHEL with regard to the additional expenditure / difference in cost and consequential losses incurred by BHEL shall be final and binding on the supplier.</p> <p>c) The amount recoverable under risk purchase shall be recovered from the defaulted supplier in all or any of the following manners:</p> <p>i) from dues available in the form of Bills payable to defaulted supplier, SD, BGs against the same contract.</p> <p>ii) from the dues payable to defaulted supplier against other contracts in the same Region/Unit /any other region/unit</p> <p>iii) In-case recoveries are not possible with any of the above available options, Legal action shall be initiated for recovery against defaulted supplier.</p> <p>d). GST will be applicable to the amount recoverable under risk purchase.</p>	
16	<p>Warranty / Guarantee: Supplier to accept guarantee/warranty of "18 months from the date of dispatch or 12 months from the date of commissioning, whichever is earlier".</p> <p>Supplier shall replace defective material free of cost (inclusive of all Testing, Inspection, TPI, Service charges etc.) up to destination within two months from defect notification date.</p>	
17	<p>Non-Disclosure Agreement(NDA): The bidders shall enter into the Non-disclosure agreement totally voluntarily, with full knowledge of its meaning and without duress. (Format attached).</p>	
18	<p>Patent Right The supplier shall, at all times, indemnify and keep indemnified the purchaser, free of cost, against all claims which may arise in respect of goods & services to be provided by the supplier under the contract for infringement of any intellectual property rights or any other right protected by patent, registration of designs or trademarks. In the event of any such claim in respect of alleged breach of patent, registered designs, trademarks etc. being made against the purchaser, the purchaser shall notify the supplier of the same and the supplier shall, at his own expenses take care of the same for settlement without any liability to the purchaser.</p>	
19	<p>PARTICULARS TO BE FURNISHED BY FOREIGN VENDORS FOR EVALUATION OF BIDS WITH CUSTOMS DUTY BENEFIT</p> <p>A. Whether PTA/ CEPA or any other agreement/treaty between respective Governments/Countries exists and the same is applicable for your supplies w.r.t this Enquired Items/tender.</p> <p>B. If yes, mention the Concessional Customs Duty (Such Duty Benefits)</p> <p>C. Documentary proof for the applicable Concessional Customs Duty (eg. PTA/ CEPA or other agreement) shall be submitted along with the Part-1 bid.</p> <p>D. Relevant documents and details to avail the above concessional duty benefits by BHEL shall be submitted by the supplier along with dispatch documents</p> <p>E. In the event of seller failing to provide appropriate documents along with dispatch documents for purchasers to avail disclosed concessional duty benefits in India, financial loss, so incurred, will be to the seller's account.</p> <p>Note: Evaluation of the Price bids will be based on the above details only and unless mentioned/furnished by the vendor, Customs Duty benefit will not be applied for evaluation purposes.</p>	<p>VENDOR COMMENTS</p> <p>YES / NO</p> <p>%</p> <p>SUBMITTED/ NOT SUBMITTED</p> <p>CONFIRMED/ NOT CONFIRMED</p> <p>CONFIRMED/ NOT CONFIRMED</p>
20	<p>Role of Agents</p> <p>a. BHEL strongly discourages the engagement of Agents by foreign principals, to deal with BHEL, in BHEL's tenders.</p> <p>b. In case of foreign suppliers representing through their Indian/foreign agents, agency agreement should be submitted, else offer is liable for rejection. Agency agreement requirements attached as separate file and full compliance to it shall be ensured while submitting the same.</p> <p>c. BHEL, due to business reasons would ban, would have banned Indian agents from dealing with BHEL. Any foreign principal who engages such a banned agent, or an employee of the banned agency, or any other person connected with the banned agency, at any time during the tender proceedings, would be disqualified from the tender proceedings. The decision of BHEL in this regard shall be final and be binding on the OEM. Hence in their own interests, prospective tenderers may check with BHEL. The list of banned firms is available on BHEL website www.bhel.com.</p> <p>Vendors/ principals proposing to deal with BHEL by engaging and through an Indian Agent does so at their own risk. BHEL shall in no way be responsible for any consequences that may arise to the foreign principal on account of the antecedents / actions of their Indian agent.</p>	

21	<p>Agency Commission:</p> <ol style="list-style-type: none"> If overseas principal has any tie-up with any third party/ agents, it should be declared while submitting offers. In respect of offers from overseas suppliers, agency commission, if any, payable to their agents in India, shall invariably be shown separately in the Performa invoice and this will be paid by BHEL in India, in Indian rupees, on satisfactory completion of the contract. Copies of current agency agreement / authorization letter in respect of agency commission shall be furnished along with offer. For calculation of rupee equivalent agency commission, exchange rate as prevailing on the date of order will be taken. 	
22	<p>Evaluation Criteria:</p> <p>The Evaluation Currency for this tender shall be "INR". The offers of vendors will be evaluated on total landed cost to BHEL, Trichy. The evaluation process is as detailed below:</p> <p>Indigenous:</p> <p>Total Landed cost = FOR Rate in INR (A) + Applicable Taxes (B) + Loading for payment term & LD (C) – Applicable input tax credit (D)</p> <ol style="list-style-type: none"> Indigenous vendors submit offers on Free on Road (FOR), Trichy in INR. GST and any other charges quoted by indigenous vendors will be added to the base price. Loading for payment terms & non-acceptance of Liquidated Damages (LD) will be added to the FOR value for arriving the landed rate. However, input credit is availed for GST (SGST, CGST/IGST), hence the same is excluded for arriving at the landed cost. <p>Import:</p> <p>Total Landed cost = CFR Rate in INR (A) + Applicable Duties (B) + Incidental Charges (C) + Loading for payment term & LD (D)</p> <ol style="list-style-type: none"> Import vendors to submit offers on CFR (Cost & Freight), Chennai port (LILo – Liner In Liner Out) basis in foreign currency, which will be converted to INR by multiplying with the Exchange rate (SBI TT Selling rate) as on the technical bid opening date. Customs duty, Safe guard duty and antidumping duty as applicable will be added to the INR price. Incidental charges of 2.26% will be added to the CFR Value. The incidental charge is inclusive of Insurance, port handling charges, & freight charges for movement from Chennai port to BHEL, Trichy. Loading for payment terms & Non-acceptance of Liquidated Damages (LD) will be added to the CFR value for arriving at the landed cost. <p>Note: "In the course of evaluation, if more than one bidder happens to occupy L1 status, effective L1 will be decided by soliciting discounts from the respective L1 bidders. In case more than one bidder happens to occupy the L1 status even after soliciting discounts, the L1 bidder shall be decided by a toss/draw of lots, in the presence of the respective L1 bidders or their representatives. Ranking will be done accordingly. BHEL decision in such situations shall be final and binding".</p>	
23	<p>General condition:</p> <ol style="list-style-type: none"> Bids including all enclosures and supporting documents like catalogues, pamphlets, etc., shall be submitted / uploaded in ENGLISH language only. If the documents submitted have other than English language, translation of the same shall be provided for evaluation. Multiple PO may also be placed considering the applicable duty structure of the respective requirement/Qty. No revision of prices will be entertained after the tenders are opened. For the evaluation purposes, exchange rate (TT selling rate of SBI) as on schedule date of tender opening (Part I, i.e technical bid, in case of two part bid) shall be considered. BHEL will consider the ranking after the loading is applied wherever deviations are observed. BHEL reserves the right to negotiate L1 rate or re-float the tender opened if L1 price is not the lowest acceptable price to them inter-alia other reasons. In the event of our customer order covering this tender being cancelled / placed on hold / otherwise modified, BHEL would be constrained to accordingly cancel / hold / modify the tender / your purchase order at any stage of execution. 	

	<p>h) Offer will be evaluated based on Landed cost to BHEL- Trichy on total package basis only.</p> <p>i) Vendor should physically weigh the materials before stuffing them into container and incorporate the same in BL and packing slip</p> <p>j) Offers for partial quantities of a given item are not acceptable to BHEL. While tenderers can quote for some or all the tendered items, no supplier shall quote for partial quantity of any given enquiry item. Such partial offer would not be considered in the enquiry for that item.</p> <p>k) No payment will be made for the excess quantity.</p> <p>l) Offer should be submitted only as per the Unit of Measurement (UOM) specified in the enquiry.</p> <p>m) The offers of the bidders who are on the banned list as also the offer of bidders who engage the services of the banned firms, shall be rejected. The list of banned firms is available on the BHEL website - www.bhel.com.</p> <p>n) Documents not signed and stamped by the authorized signatory of the bidder shall not be accepted and considered for registration / evaluation of the bid etc.</p> <p>o) Any additional documents submitted by supplier / bidder, during processing of registration application / tender or after placement of order, shall not be accepted unless it is submitted with forwarding letter and duly signed and stamped as mentioned above.</p> <p>p) All documents submitted with the offer shall be signed and stamped in each page by authorized representative of the bidder.</p> <p>q) This Tender is hosted in EPS portal & offer to be submitted through EPS portal only. You are requested to submit your 2 parts offer before due date & time of the enquiry through NIC (https://eprocurebhel.co.in) only. SEALED COVER BIDS / E-MAILS / FAX / MANUAL OFFERS WILL NOT BE ACCEPTED.</p> <p>For any clarification you can contact to thambi@bhel.in Contact nos. 04312577492.</p>	
24	<p>Fraud Prevention Policy</p> <p>"The bidder along with its associate/collaborators/sub-contractors /consultants/service providers shall strictly adhere to BHEL Fraud prevention policy displayed on BHEL website http://www.bhel.com and shall immediately bring to the notice of BHEL Management about fraud or suspected fraud as soon as it comes to their notice."</p>	
25	<p>Suspension of Business Dealings with Suppliers/Contractors:</p> <p>The offers of the bidders who are under suspension as also the offers of the bidders, who engage the services of the banned firms /principal/agents, shall be rejected. The list of banned firms is available on BHEL web site www.bhel.com.</p> <p>Integrity commitment, performance of the contract and punitive action thereof:</p> <p>Commitment by BHEL</p> <p>BHEL commits to take all measures necessary to prevent corruption in connection with the tender process and execution of the contract. BHEL will during the tender process treat all Bidder(s) in a transparent and fair manner, and with equity.</p> <p>Commitment by Bidder/ Supplier/ Contractor</p> <ul style="list-style-type: none"> • The bidder/ supplier/ contractor commit to take all measures to prevent corruption and will not directly or indirectly influence any decision or benefit which he is not legally entitled to nor will act or omit in any manner which tantamount to an offence punishable under any provision of the Indian Penal Code, 1860 or any other law in force in India. • The bidder/ supplier/ contractor will, when presenting his bid, disclose any and all payments he has made, and is committed to or intends to make to agents, brokers or any other intermediaries in connection with the award of the contract and shall adhere to relevant guidelines issued from time to time by Govt. of India/ BHEL. • The bidder/ supplier/ contractor will perform/ execute the contract as per the contract terms & conditions and will not default without any reasonable cause, which causes loss of business/ money/ reputation, to BHEL. <p>If any bidder/ supplier/ contractor during pre-tendering/ tendering/ post tendering/ award/ execution/ post-execution stage indulges in any act, including but not limited to, mal-practices, cheating, bribery, fraud or and other misconduct or formation of cartel so as to influence the bidding process or influence the price or tampers the tendering process or acts or omits in any manner which tantamount to an offence punishable under any provision of the Indian Penal Code, 1860 or any other law in force in India or does anything which is actionable</p>	

	under the Guidelines for suspension of business dealing, then, action may be taken against such bidder/supplier/ contractor as per extant guidelines of the company available on www. bhel.com and/or under applicable legal provisions. Guidelines for suspension of business dealings_is available in the webpage: http://www.bhel.com/vender_registration/vender.php .	
26	<p><u>Cartel Formation:</u></p> <p>The Bidder declares that they will not enter into any illegal or undisclosed agreement or understanding, whether formal or informal with other Bidder(s). This applies in particular to prices, specifications, certifications, subsidiary contracts, submission or non-submission of bids or any other actions to restrict competitiveness or to introduce cartelization in the bidding process. In case, the Bidder is found having indulged in above activities, suitable action shall be taken by BHEL as per extant policies/ guidelines.</p>	
27	<p><u>Resolution of Disputes:</u></p> <p>The Parties agree that if at any time (whether before, during or after the arbitral or judicial proceedings), any Disputes (which term shall mean and include any dispute, difference, question or disagreement arising in connection with construction, meaning, operation, effect, interpretation or breach of the contract/tender which the Parties are unable to settle mutually), arise inter-se the Parties, the same may, be referred by either party to Conciliation to be conducted through Independent Experts Committee to be appointed by competent authority of BHEL from the BHEL Panel of Conciliators.</p> <p>The proceedings of Conciliation shall broadly be governed by Part-III of the Arbitration and Conciliation Act 1996 or any statutory modification thereof.</p> <p><u>Notes:</u></p> <ol style="list-style-type: none"> 1. No serving or a retired employee of BHEL/Administrative Ministry of BHEL shall be included in the BHEL Panel of Conciliators. 2. Any other person(s) can be appointed as Conciliator(s) who is/are mutually agreeable to both the parties from outside the BHEL Panel of Conciliators. <p>The proceedings of Conciliation shall broadly be governed by Part-III of the Arbitration and Conciliation Act 1996 or any statutory modification thereof and as provided in Annexure X to this Enquiry Conditions.</p> <p>The Annexure together with its appendices will be treated as if the same is part and parcel hereof and shall be as effectual as if set out herein in these Enquiry Conditions.</p> <p>Except as provided elsewhere in this Contract, in case amicable settlement is not reached between the parties, in respect of any dispute or difference; arising out of the formation, breach, termination, validity or execution of the Contract; or, the respective rights and liabilities of the Parties; or, in relation to interpretation of any provision of the Contract ; or , in any manner touching upon the Contract, then, either Party may , by a notice in writing to other Party refer such dispute or difference to sole arbitration of an arbitrator appointed as per the Arbitration and Conciliation Act, 1996 (India) or statutory modification or re-enactment thereof and the rules made thereunder and for the time being in force .</p> <p>The Arbitrator shall pass a reasoned award and the award of the Arbitrator shall be final and binding upon the parties. Subject as aforesaid, the provision of Arbitration & Conciliation Act 1996 (India) or statutory modification or re-enactment thereof and the rules made thereunder and for the time being in force shall apply to the arbitration proceeding under this clause.</p> <p>The seat of arbitration shall be Trichy, Tamil Nadu, India. The cost of arbitration shall be borne as per the award of the Arbitrator. Subject to arbitration in terms of clause above, the Courts at Trichy, Tamil Nadu, India shall have exclusive jurisdiction over any matter arising out of or in connection with this Contract.</p> <p>Notwithstanding the existence or any dispute or difference and/or reference for the arbitration, the vendor shall proceed with and continue without hindrance the performance of its obligation under this Contract with due diligence and expedition in a professional manner except where the Contract has been terminated by either Party in terms of this Contract.</p> <p><u>In Case of Contract with Public Sector Enterprise (PSE) or a Government Department, the following shall be applicable:</u></p> <p>In the event of any dispute or difference relating to the interpretation and application of the provisions of commercial contract(s) between Central Public Sector Enterprises (CPSEs)/Port Trusts <i>inter se</i> and also between CPSEs and Government Departments/Organizations (Excluding disputes concerning Railways, Income Tax, Customs & Excise Departments, such dispute or difference shall be taken up by either party for resolution through AMRCD as mentioned in DPE OM No. 4(1)/2013 –DPE (GM)/FTS-1835 dated 22-05-2018.</p>	

29	<p><u>In the event of Force Majeure:</u></p> <p>a. Notwithstanding the provisions contained in other clauses, the supplier shall not be liable for imposition of any such sanction so long the delay and/or failure of the supplier in fulfilling its obligations under the contract is the result of an event of Force Majeure. For purposes of this clause, Force Majeure means an event beyond the control of the supplier and not involving the supplier's fault or negligence and which is not foreseeable and not brought about at the instance of the party claiming to be affected by such event and which has caused the non – performance or delay in performance. Such events may include, but are not restricted to, wars or revolutions, hostility, acts of public enemy, civil commotion, sabotage, fires, floods, explosions, epidemics, quarantine restrictions, strikes excluding by its employees, lockouts excluding by its management, freight embargoes and Acts of GOD.</p> <p>b. If a Force Majeure situation arises, the supplier shall promptly notify the Purchaser/Consignee in writing of such conditions and the cause thereof within twenty-one days of occurrence of such event. Unless otherwise directed by the Purchaser/Consignee in writing, the supplier shall continue to perform its obligations under the contract as far as reasonably practical, and shall seek all reasonable alternative means for performance not prevented by the Force Majeure event.</p> <p>c. If the performance in whole or in part or any obligation under this contract is prevented or delayed by any reason of Force Majeure for a period exceeding sixty days, either party may at its option terminate the contract without any financial repercussion on either side.</p> <p>d. In case due to a Force Majeure event the Purchaser/Consignee is unable to fulfil its contractual commitment and responsibility, the Purchaser/Consignee will notify the supplier accordingly and subsequent actions taken on similar lines described in above sub-paragraphs.</p>	
30	<p><u>Execution of the order:</u></p> <p>a. BHEL will have the option to pre-inspect the materials at Supplier's works by BHEL's own inspector or by third party agency appointed by BHEL or BHEL's end customer/s.</p> <p>b. If the inspection fails, the vendor shall offer the material again as per ordered terms and specifications for further inspection.</p> <p>c. The mere act of the pre-dispatch inspection (PDI) does not absolve the Supplier from giving the specifications as agreed upon in the Purchase Order.</p> <p>d. In the case of overseas suppliers Inspection call for carrying out the inspection shall be given 30 days before the scheduled contract delivery date. The Inspection date/s given by the Supplier shall be on firm basis. For local Suppliers the Notice period of Inspection shall be 10 working days.</p> <p>e. In the event of any short supply, it shall be the responsibility of the supplier to deliver such short supplied/ missing items on Free-of-Cost basis at BHEL stores, including customs clearances at Indian Ports in the case of foreign suppliers.</p>	
31	<p><u>Set-off Clause:</u></p> <p>BHEL shall have the right to recover any money which in the sole opinion of BHEL is due from the Contractor from any money due to the Contractor under this Contract or any other contract or from the Security Deposit furnished by the Contractor under this Contract or any other contract.</p>	
32	<p><u>Caution:</u></p> <p>a) The suppliers are severely cautioned to note that the price bid document accepts the price in figures only. It does not allow the supplier to write the value by words. Therefore, all care shall be exercised by the supplier while filling in the figures. Once the price bid is opened no option is available for the supplier to retract the offer under any grounds. If a supplier, for any reason whatsoever approaches BHEL with a request for change in the price, it would be treated as going back on the offer submitted. In such cases, action would be initiated by BHEL for suspending further business dealings with such suppliers as per policy of BHEL which prevails at that point of time.</p> <p>b) The language in the tender documents downloaded by the Bidders shall at no point of time be changed, altered or modified in any manner by the Tenderer. If such changes are made by any tenderer, it shall be considered as tampering with BHEL's terms and the offer shall be summarily rejected, whenever it is noticed by BHEL. Such Bidders would be disqualified from the Bidding Process and their offers would be forfeited / Bank Guarantees invoked. They would also not be allowed to participate in future tenders of BHEL.</p>	
33	<p><u>Special Provisions for Micro and Small Enterprises (MSE) bidders registered as per MSME act:</u> (Subject to participating MSE vendors meeting the tender requirements of BHEL)</p> <p>a) As per Gazette Notification no. S.O. 2119(E) dated 26.06.2020 issued by Ministry of MSME applicable/existing Micro and small suppliers are requested to get registered with Udyam Registration portal and share us the Udyam registration no along with Udyam registration certificate.</p> <p>b) 25% of the tendered quantity is earmarked for MSE suppliers in this tender, subject to participating MSE Vendors should meet the tender requirements of BHEL. In case MSE vendor participating in the tender quotes within the price band of L1 + 15%, they will be allowed to supply the portion of the requirement subject to acceptance of L1 price by MSE vendor. In case of more than one such MSE vendor within the "L1+15% price band", the supply shall be shared proportionately.</p>	

	<p>c) In the event of Non MSE supplier becoming L1 and MSE supplier quotes within the price band of L1+15% and it is not possible to split the tendered quantity on account of reasons like customer contract requirement/technical requirements, then 100% of the quantity will be offered to MSE suppliers subject to acceptance of L1 price by MSE supplier.</p> <p>d) Counter offering of L1 rate will not be made with any MSE vendor whose quoted rate is more than the price band of L1+15%.</p> <p>e) Payment to MSE vendor will be as per the applicable provisions of the MSMED Act 2006.</p> <p>f) If L1 offer is from a Micro / Small enterprise, the 25% earmarking provision is not applicable.</p> <p>g) Out of the 25% tendered quantity reserved for MSE suppliers, 6.25% shall be earmarked for procurement from MSE owned by SC/ST entrepreneurs. Apart from this 3% shall be earmarked for procurement from MSE owned by Women entrepreneurs.</p> <p>h) In case of any change in the MSE status of the bidder, it shall be the responsibility of the bidder to notify the change as a part of the bid document. If at a later date it comes to the knowledge of BHEL, that the change in the status has not been intimated by the bidder and the order is obtained under the premise of an MSE then BHEL would cancel the pending order against this tender and take necessary steps for suspension of the business dealing with the bidder as per the procurement policy of BHEL.</p> <p>i) MSE suppliers can avail the intended benefits only if they submit along with the offer, Valid EM-II certificate along with CA certificate or valid NSIC certificate or UAM certificate along with attested copy of a CA certificate (Format enclosed as below) applicable for the relevant financial year (latest audited). Date to be reckoned for determining the deemed validity will be the date of bid opening (Part 1 in case of two part bid). Non submission of such documents will lead to consideration of their bid at par with other bidders. No benefit shall be applicable for this enquiry if any deficiency in the above required documents are not submitted before price bid opening. Documents should be notarized or attested by a Gazetted officer. However, credentials of all MSE suppliers will be verified before considering the intended benefits for MSE suppliers at the time of tender evaluation. Non submission of such documents will lead to consideration of their bids at par with other bidders and MSE status of such suppliers shall be shifted to Non MSE supplier till the supplier submits these documents.</p>	
34	<p>Preference to Make in India: For this procurement, the local content to categorize a supplier as a class I local supplier/class II local supplier /Non-local supplier and purchase preference to class I local supplier, is as defined in Public Procurement (Preference to Make in India), Order 2017 dated 04.06.2020 issued by DPIIT. In case of subsequent Orders issued by the respective Nodal Ministry, changing the definition of local content for the items of the NIT, the same shall be applicable even if issued after issue of this NIT, but before opening of part II bids against this NIT.</p>	
35	<p>Restrictions for Procurement from a country sharing its land border with India For this procurement, Public procurement order dated 23.07.2020 regarding restrictions under rule 144 (xi) of general financial rules 2017 and clarification dt 08.02.2021 from DoE is applicable. In case of subsequent Orders issued, the same shall be applicable even if issued after issue of this NIT.</p>	
36	<p>Enclosures:</p> <p>a) Enquiry b) Technical Specification- FP: FLN: 02 Rev 00 c) Technical PQR</p>	
<p>THAMBI Digitally signed by DURAI M THAMBIDURAI M Date: 2022.10.11 09:42:57 +05'30'</p>		<p>SIGNED BY MANUFACTURER / MILL</p> <p>Name of Mill: Designation / Department: Seal & Signature</p>

Annexure C

VENDOR DETAILS

SL NO	DESCRIPTION	To be filled by bidder
1	VENDOR NAME	
2	QUOTATION REFERENCE	
3	QUOTATION DATE	
4	TELE, MOBILE NO	
5	FIRM MAIL ID	
6	CONTACT PERSON	
7	OFFICE ADDRESS	
8	ORDER TO BE PLACED ON	
9	COUNTRY OF ORIGIN	
10	QUOTED CURRENCY	
11	PORT OF LOADING	
12	PORT OF DISCHARGE	

Vendor Seal & Sign

	Bharat Heavy Electricals Ltd High Pressure Boiler Plane(HPBP) Trichy-620014	Department	PE(FB)
		Section	Pressure Parts
		Application	FGD

			<i>D. Karthik</i>	<i>D. Venkat Doodi</i>	<i>Nirmalraj N</i>
00	16-07-2022	Fresh Release	Karthik D	Venkat Doodi	Nirmalraj N
REV.	DATE	DESCRIPTION	PREPARED	CHECKED	APPROVED

Sl.no	Items		Vendor Acceptance/ Comments
		1. C276 FLANGE 2" (50NB) FLAT FACED 2. C-276 FLANGE 3" (80NB) FLAT FACED	
1	Scope of supply	Flanges of 2" and 3" flat faced as per attached drawing and enquiry.	
2	Application	Wet & Dry interface system of FGD	
3	Material	Haste alloy C 276 (UNS No. N10276)	
4	Documents to be submitted	(a) The Vendor shall furnish point wise reply and submit seal & signed copy of this specification along with drawing. (b) The Vendor shall submit the dimensional drawings indicating materials of construction and weight along with the offer for information.	
6	Inspection	a) Inspection by BHEL or its authorized agency. b) Inspection as per approved drawing. c) Material test certificate shall be submitted.	
7	Packing	Items shall be wrapped in a polythene hessian and the package shall be kept in a wooden box prior to dispatch.	
8	Outside the box	PO number, vendor name, item, material code, Quantity inside the box to be mentioned.	
9	Approval	Drawing approval from BHEL is required before manufacturing.	
10	Destination	BHEL, HPBP Trichy, Tamilnadu-620014	
11	Drawing	3-FP-870-00001 (Attached Page2)	

Bidder's seal & sign

3-FP-870-00001 DRAWING NO:

FOR TOLERANCES OF UNTOLERANCED
DIMENSIONS DURING MANUFACTURE
REFER PLANT STD.NO TP 023 0299

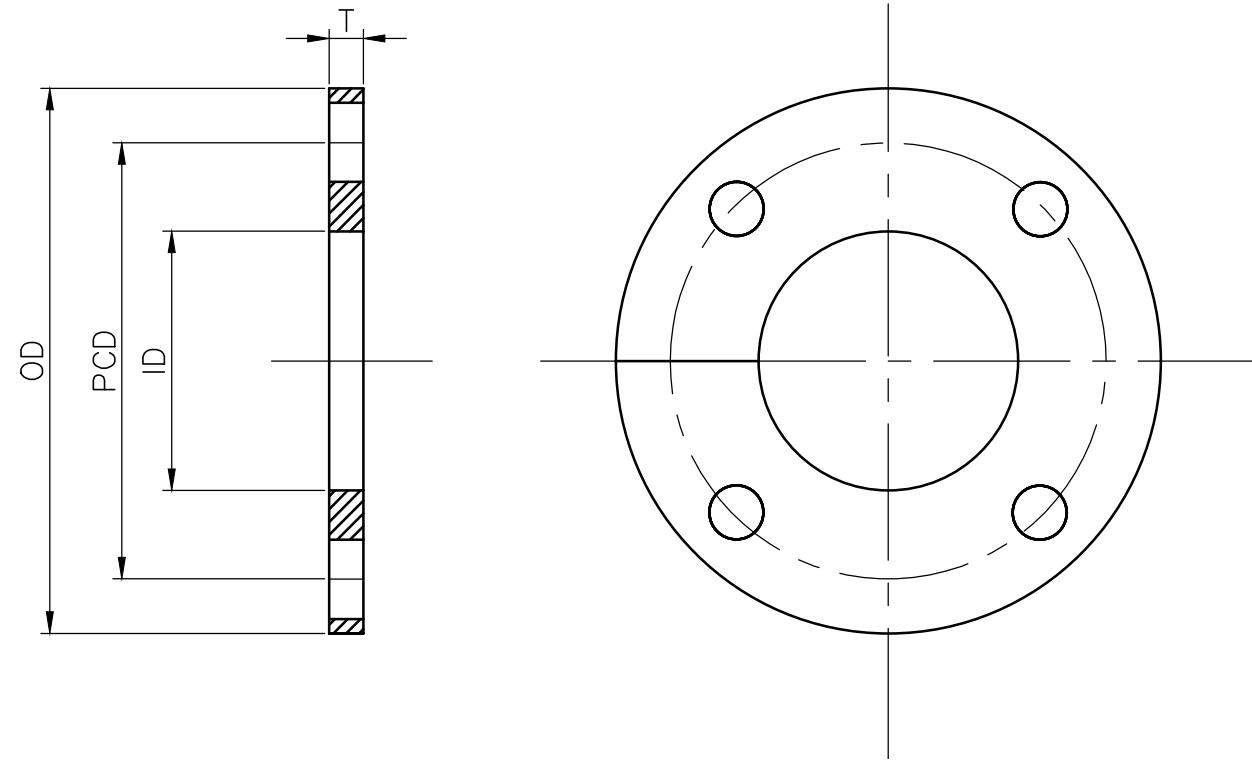

C 276 FLANGE FLAT FACED						
SIZE	OD	THICKNESS (T)	ID	PCD	HOLES DIA	NO OF HOLES
2"	152.4	10	61.9	120.6	19	4
3"	190.5	12	90.6	152.4	19	4

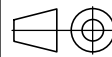
TYPE OF PRODUCT OR NAME OF CUSTOMER/PROJECT		WET & DRY INTERFACE SYSTEM OF FGD			
 Bharat Heavy Electricals Ltd UNIT: HIGH PRESSURE BOILER PLANT TIRUCHIRAPALLI - 620014 355-055	DRN	NAME	SIGNATURE	DATE	
	CHD	VENKAT D		20.07.22	
	APPD	NIRMAL RAJ		20.07.22	
DEPT	PP	ALL DIMENSIONS ARE IN MM	PROJECTION	SCALE	WEIGHT (Kg)
CODE	121			N.T.S	
TITLE				REF TO ASSY / OLD DWG	
C 276 FLANGE FLAT FACED				DRAWING NO :	REV
				3-FP-870-00001	00

CAUTION: The information on this document is the property of BHARAT HEAVY ELECTRICALS LTD. It must not be used directly or indirectly in any way detrimental to the interest of the company.

REV	DATE	ALTERED :
01		CHD & APPD:
ZONE		

**TECHNICAL PRE-QUALIFICATION REQUIREMENT FOR SUPPLY OF
C276 (UNS N10276) FLANGES (SPECIFICATION FP: FLN: 02).**

1. Bidder must have the experience of supplying C276 (UNS N10276) spec material/similar spec special material.

Following supporting documents to be submitted as a proof:

- a. Unpriced PO copies.
 - b. Proof of supply (such as Invoice / LWB copies)
 - c. Test certificate of previously executed purchase order of C 276 (UNS N10276) material /similar material.
2. Bidder should confirm that supply of C276(UNS N10276) Flanges shall be as per Technical Specification: FP: FLN: 02 Rev 00.
 3. Offers of bidders who have quoted for all the variants of Flanges will only be considered, since evaluation will be done as a single package.

VENKATES Digitally signed
WARA by
RAO VENKATESWARA
DOODI RAO DOODI
Date: 2022.10.10
16:24:57 +05'30'

 BHEL - TRICHY	THIRD PARTY NON-DISCLOSURE AGREEMENT	Doc.No. : ISMS-04/TP/011	
		Ver. No: 3.0	Rev. No: 00
		Date : 27 - 10 - 14	

THIRD PARTY NON-DISCLOSURE AGREEMENT

I, _____, on behalf of the _____ (Name of Company), acknowledge that the information received or generated, directly or indirectly, while working with BHEL, Trichy on contract is confidential and that the nature of the business of the BHEL, Trichy is such that the following conditions are reasonable, and therefore:

I warrant and agree as follows:

I, or any other personnel employed or engaged by our company, agree not to disclose, directly or indirectly, any information related to the BHEL, Trichy Without restricting the generality of the foregoing, it is agreed that we will not disclose such information consisting but not necessarily limited to:

- Technical information: Methods, drawings, processes, formulae, compositions, systems, techniques, inventions, computer programs/data/configuration and research projects.
- Business information: Customer lists, project schedules, pricing data, estimates, financial or marketing data,

On conclusion of contract, I, or any other personnel employed or engaged by our company shall return to BHEL, Trichy all documents and property of BHEL, Trichy, including: drawings, blueprints, reports, manuals, computer programs/data/configuration, and all other materials and all copies thereof relating in any way to BHEL, Trichy 's business, or in any way obtained by me during the course of contract. I further agree that I, or any others employed or engaged by our company shall not retain copies, notes or abstracts of the foregoing.

This obligation of confidence shall continue after the conclusion of the contract also.

I acknowledge that the aforesaid restrictions are necessary and fundamental to the business of the BHEL, Trichy and are reasonable given the nature of the business carried on by the BHEL, Trichy I agree that this agreement shall be governed by and construed in accordance with the laws of country.

I enter into this agreement totally voluntarily, with full knowledge of its meaning, and without duress.

Dated at _____, this ____ day of _____, 20__.

Name

Company

Signature

In line with Government Public Procurement Order No. P-45021/2/2017-BE-II dt. 15.06.2017 & P-45021/2/2017-PP (BE-II) dated 28.05.2018, we hereby certify that we

.....
(supplier name) are local supplier meeting requirement of minimum local content (50%) defined in as above orders for the material against Enquiry No.

.....
Details of location at which local value addition will be made is as follows:

.....
.....
.....
We also understand, false declarations will be in breach of the Code of Integrity under Rule 175(1)(i)(h) of the General Financial Rules for which a bidder or its successors can be debarred for up to two years as per Rule 151 (iii) of the General Financial Rules along with such other actions as may be permissible under law.

Seal and Signature of Supplier