



Bid Number/बोली क्रमांक (बिड संख्या):  
GEM/2023/B/3058344  
Dated/दिनांक : 31-01-2023

**Bid Document/ बिड दस्तावेज़**

<b>Bid Details/बिड विवरण</b>	
<b>Bid End Date/Time/बिड बंद होने की तारीख/समय</b>	10-02-2023 16:00:00
<b>Bid Opening Date/Time/बिड खुलने की तारीख/समय</b>	10-02-2023 16:30:00
<b>Bid Offer Validity (From End Date)/बिड पेशकश वैधता (बंद होने की तारीख से)</b>	180 (Days)
<b>Ministry/State Name/मंत्रालय/राज्य का नाम</b>	Ministry Of Heavy Industries And Public Enterprises
<b>Department Name/विभाग का नाम</b>	Department Of Heavy Industry
<b>Organisation Name/संगठन का नाम</b>	Bharat Heavy Electricals Limited (bhel)
<b>Office Name/कार्यालय का नाम</b>	10250020-pem, Noida
<b>Total Quantity/कुल मात्रा</b>	43

**Bid Details/बिड विवरण**

<p><b>Item Category/मद केटेगरी</b></p>	<p>As per sl. no. A of BOQ at page 1 of technical specification i.e. FDV-14 Low Load Feed Control Valve , As per sl. no. B of BOQ at page 1 of technical specification i.e. 1,4 inch SS TUBING 25 METER FOR EACH TAG , As per sl. no. C 1 of BOQ at page 1 of technical specification i.e. SS FITTINGS for connection to Air Filter Regulator- FOR EACH TAG , As per sl. no. C 2 of BOQ at page 1 of technical specification i.e. SS FITTINGS for connection to Air Lock Relay- FOR EACH TAG , As per sl. no. C 3 of BOQ at page 1 of technical specification i.e. SS FITTINGS for connection to IA Header Isolation Valve - FOR EACH TAG , As per sl. no. C 4 of BOQ at page 1 of technical specification i.e. SS EQUAL TEE - FOR EACH TAG , As per sl. no. C 5 of BOQ at page 1 of technical specification i.e. SS 1,2 inch NPT M X 1,4 inch OD TUBE CONNECTOR- FOR EACH TAG , As per sl. no. D of BOQ at page 1 of technical specification i.e. VALVE DIAGNOSTIC AND CONFIGURATION SOFTWARE FOR ALL TAGS , As per sl. no. E of BOQ at page 1 of technical specification i.e. CV TEST CHARGE , COMMISSIONING SPARES - As per sl. no. 1 of BOQ at page 1 of technical specification i.e. Gaskets , COMMISSIONING SPARES - As per sl. no. 2 of BOQ at page 1 of technical specification i.e. Gland Packing , MANDATORY SPARES - As per sl. no. 1 of BOQ at page 1 of technical specification i.e. Bonnet Seal , MANDATORY SPARES - As per sl. no. 2 of BOQ at page 1 of technical specification i.e. Gland Packing , MANDATORY SPARES - As per sl. no. 3 of BOQ at page 1 of technical specification i.e. Plug Seat Cage Stem etc , MANDATORY SPARES - As per sl. no. 4 of BOQ at page 1 of technical specification i.e. Retainer Ring Seal Ring etc , MANDATORY SPARES - As per sl. no. 5 of BOQ at page 1 of technical specification i.e. Actuator Seal Kit for Pneumatic Cylinder , MANDATORY SPARES - As per sl. no. 6 of BOQ at page 1 of technical specification i.e. Smart Positioner of the Valve , MANDATORY SPARES - As per sl. no. 7 of BOQ at page 1 of technical specification i.e. Position Feedback Transmitter - applicable if it is not integral with the Smart Positioner</p>
<p><b>BOQ Title/बीओक्यू शीर्षक</b></p>	<p>LOW LOAD FEED CONTROL VALVE FDV14 FOR SAGARDIGHI UNIT 5</p>
<p><b>MSE Exemption for Years of Experience/अनुभव के वर्षों से एमएसई छूट/ and Turnover</b></p>	<p>No</p>
<p><b>Startup Exemption for Years of Experience/अनुभव के वर्षों से स्टार्टअप छूट/ and Turnover</b></p>	<p>No</p>
<p><b>Document required from seller/विक्रेता से मांगे गए दस्तावेज़</b></p>	<p>Certificate (Requested in ATC),OEM Authorization Certificate,Additional Doc 1 (Requested in ATC),Additional Doc 2 (Requested in ATC),Additional Doc 3 (Requested in ATC),Compliance of BoQ specification and supporting document *In case any bidder is seeking exemption from Experience / Turnover Criteria, the supporting documents to prove his eligibility for exemption must be uploaded for evaluation by the buyer</p>
<p><b>Bid to RA enabled/बिड से रिवर्स नीलामी सक्रिय किया</b></p>	<p>Yes</p>
<p><b>RA Qualification Rule</b></p>	<p>H1-Highest Priced Bid Elimination</p>

**Bid Details/बिड विवरण**

<b>Type of Bid/बिड का प्रकार</b>	Two Packet Bid
<b>Primary product category</b>	MANDATORY SPARES - As per sl. no. 7 of BOQ at page 1 of technical specification i.e. Position Feedback Transmitter - applicable if it is not integral with the Smart Positioner
<b>Time allowed for Technical Clarifications during technical evaluation/तकनीकी मूल्यांकन के दौरान तकनीकी स्पष्टीकरण हेतु अनुमत समय</b>	2 Days
<b>Payment Timelines</b>	Payments shall be made to the Seller within <b>90</b> days of issue of consignee receipt-cum-acceptance certificate (CRAC) and on-line submission of bills (This is in supersession of 10 days time as provided in clause 12 of GeM GTC)
<b>Evaluation Method/मूल्यांकन पद्धति</b>	Total value wise evaluation

**EMD Detail/ईएमडी विवरण**

Required	No
----------	----

**ePBG Detail/ईपीबीजी विवरण**

Advisory Bank	State Bank of India
ePBG Percentage(%) / ईपीबीजी प्रतिशत (%)	5.00
Duration of ePBG required (Months) / ईपीबीजी की अपेक्षित अवधि (महीने).	28

(a). EMD & Performance security should be in favour of Beneficiary, wherever it is applicable./ईएमडी और संपादन जमानत राशि, जहां यह लागू होती है, लाभार्थी के पक्ष में होनी चाहिए।

**Beneficiary/लाभार्थी :**

SBI  
10250020-PEM, Noida, Department of Heavy Industry, Bharat Heavy Electricals Limited (BHEL), Ministry of Heavy Industries and Public Enterprises  
(Bhel Pem Noida)

**Splitting/विभाजन**

Bid splitting not applied.

**MSE Purchase Preference/एमएसई खरीद वरीयता**

MSE Purchase Preference/एमएसई खरीद वरीयता	No
---	----

**Details of the Competent Authority for MSE**

Name of Competent Authority	Ashish Kumar Gupta
Designation of Competent Authority	Manager
Office / Department / Division of Competent Authority	BHEL PEM Noida
CA Approval Number	1
Competent Authority Approval Date	30-01-2023
Brief Description of the Approval Granted by Competent Authority	As per internal approval for this package project and tender.

Competent Authority Approval for not opting Micro and Small Enterprises Preference : [View Document](#)

### Reserved for Make In India products

Reserved for Make In India products	Yes
-------------------------------------	-----

1. Bid reserved for Make In India products: : Procurement under this bid is reserved for purchase from Class 1 local supplier as defined in public procurement (Preference to Make in India), Order 2017 as amended from time to time and its subsequent Orders/Notifications issued by concerned Nodal Ministry for specific Goods/Products. However, eligible micro and small enterprises will be allowed to participate. The minimum local content to qualify as a class 1 local supplier is denoted in the bid document. All bidders must upload a certificate from the OEM regarding the percentage of the local content and the details of locations at which the local value addition is made along with their bid, failing which the bid is liable to be rejected. In case the bid value is more than Rs 10 Crore, the declaration relating to percentage of local content shall be certified by the statutory auditor or cost auditor, if the OEM is a company and by a practicing cost accountant or a chartered accountant for OEMs other than companies as per the Public Procurement (preference to Make-in -India) order 2017 dated 04.06.2020 . In case Buyer has selected Purchase preference to Micro and Small Enterprises clause in the bid, the same will get precedence over this clause.

2. Estimated Bid Value indicated above is being declared solely for the purpose of guidance on EMD amount and for determining the Eligibility Criteria related to Turn Over, Past Performance and Project / Past Experience etc. This has no relevance or bearing on the price to be quoted by the bidders and is also not going to have any impact on bid participation. Also this is not going to be used as a criteria in determining reasonableness of quoted prices which would be determined by the buyer based on its own assessment of reasonableness and based on competitive prices received in Bid / RA process.

3. Reverse Auction would be conducted amongst all the technically qualified bidders except the Highest quoting bidder. The technically qualified Highest Quoting bidder will not be allowed to participate in RA. However, H-1 will also be allowed to participate in RA in following cases:

- i. If number of technically qualified bidders are only 2 or 3.
- ii. If Buyer has chosen to split the bid amongst N sellers, and H1 bid is coming within N.
- iii. In case Primary product of only one OEM is left in contention for participation in RA on elimination of H-1.
- iv. If L-1 is non-MSE and H-1 is eligible MSE and H-1 price is coming within price band of 15% of Non-MSE L-1
- v. If L-1 is non-MII and H-1 is eligible MII and H-1 price is coming within price band of 20% of Non-MII L-1

### As Per Sl. No. A Of BOQ At Page 1 Of Technical Specification I.e. FDV-14 Low Load Feed Control Valve

**(Minimum 85% Local Content required for qualifying as Class 1 Local Supplier)**

Brand Type/ब्रांड का प्रकार	Unbranded
-----------------------------	-----------

### Technical Specifications/तकनीकी विशिष्टियाँ

<b>Specification Document</b>	<a href="#">View File</a>
<b>BOQ Detail Document</b>	<a href="#">View File</a>

Advisory-Please refer attached BOQ document for detailed consignee list and delivery period.

**Consignees/Reporting Officer/परेषिती/रिपोर्टिंग अधिकारी and/ तथा Quantity/मात्र**

<b>S.No./क्र. सं.</b>	<b>Consignee Reporting/Officer/ परेषिती/रिपोर्टिंग अधिकारी</b>	<b>Address/पता</b>	<b>Quantity/मात्र</b>	<b>Delivery Days/डिलीवरी के दिन</b>
1	Pratap Sarkar	742237,Construction Manager - BHEL site office Unit-V Sagardighi Thermal Power Project P.O. Manigram, District - Murshidabad, PIN:742237, West Bengal, India	1	999

**As Per Sl. No. B Of BOQ At Page 1 Of Technical Specification I.e. 1,4 Inch SS TUBING 25 METER FOR EACH TAG**

**(Minimum 85% Local Content required for qualifying as Class 1 Local Supplier)**

Brand Type/ब्रांड का प्रकार	Unbranded
-----------------------------	-----------

**Technical Specifications/तकनीकी विशिष्टियाँ**

<b>Specification Document</b>	<a href="#">View File</a>
<b>BOQ Detail Document</b>	<a href="#">View File</a>

Advisory-Please refer attached BOQ document for detailed consignee list and delivery period.

**Consignees/Reporting Officer/परेषिती/रिपोर्टिंग अधिकारी and/ तथा Quantity/मात्र**

S.No./क्र. सं.	Consignee Reporting/Officer/ परेषिती/रिपोर्टिंग अधिकारी	Address/पता	Quantity/मात्रा	Delivery Days/डिलीवरी के दिन
1	Pratap Sarkar	742237, Construction Manager - BHEL site office Unit-V Sagardighi Thermal Power Project P.O. Manigram, District - Murshidabad, PIN:742237, West Bengal, India	25	999

**As Per SI. No. C 1 Of BOQ At Page 1 Of Technical Specification I.e. SS FITTINGS For Connection To Air Filter Regulator- FOR EACH TAG**

**(Minimum 85% Local Content required for qualifying as Class 1 Local Supplier)**

Brand Type/ब्रांड का प्रकार	Unbranded
-----------------------------	-----------

**Technical Specifications/तकनीकी विशिष्टियाँ**

<b>Specification Document</b>	<a href="#">View File</a>
<b>BOQ Detail Document</b>	<a href="#">View File</a>

Advisory-Please refer attached BOQ document for detailed consignee list and delivery period.

**Consignees/Reporting Officer/परेषिती/रिपोर्टिंग अधिकारी and/ तथा Quantity/मात्रा**

S.No./क्र. सं.	Consignee Reporting/Officer/ परेषिती/रिपोर्टिंग अधिकारी	Address/पता	Quantity/मात्रा	Delivery Days/डिलीवरी के दिन
1	Pratap Sarkar	742237, Construction Manager - BHEL site office Unit-V Sagardighi Thermal Power Project P.O. Manigram, District - Murshidabad, PIN:742237, West Bengal, India	1	999

**As Per SI. No. C 2 Of BOQ At Page 1 Of Technical Specification I.e. SS FITTINGS For Connection To Air Lock Relay- FOR EACH TAG**

**(Minimum 85% Local Content required for qualifying as Class 1 Local Supplier)**

Brand Type/ब्रांड का प्रकार	Unbranded
-----------------------------	-----------

**Technical Specifications/तकनीकी विशिष्टियाँ**

<b>Specification Document</b>	<a href="#">View File</a>
<b>BOQ Detail Document</b>	<a href="#">View File</a>

Advisory-Please refer attached BOQ document for detailed consignee list and delivery period.

**Consignees/Reporting Officer/परेषिती/रिपोर्टिंग अधिकारी and/ तथा Quantity/मात्र**

<b>S.No./क्र. सं.</b>	<b>Consignee Reporting/Officer/ परेषिती/रिपोर्टिंग अधिकारी</b>	<b>Address/पता</b>	<b>Quantity/मात्र</b>	<b>Delivery Days/डिलीवरी के दिन</b>
1	Pratap Sarkar	742237, Construction Manager - BHEL site office Unit-V Sagardighi Thermal Power Project P.O. Manigram, District - Murshidabad, PIN:742237, West Bengal, India	1	999

**As Per SI. No. C 3 Of BOQ At Page 1 Of Technical Specification I.e. SS FITTINGS For Connection To IA Header Isolation Valve - FOR EACH TAG**

**(Minimum 85% Local Content required for qualifying as Class 1 Local Supplier)**

Brand Type/ब्रांड का प्रकार	Unbranded
-----------------------------	-----------

**Technical Specifications/तकनीकी विशिष्टियाँ**

<b>Specification Document</b>	<a href="#">View File</a>
<b>BOQ Detail Document</b>	<a href="#">View File</a>

Advisory-Please refer attached BOQ document for detailed consignee list and delivery period.

**Consignees/Reporting Officer/परेषिती/रिपोर्टिंग अधिकारी and/ तथा Quantity/मात्र**

S.No./क्र. सं.	Consignee Reporting/Officer/ परेषिती/रिपोर्टिंग अधिकारी	Address/पता	Quantity/मात्रा	Delivery Days/डिलीवरी के दिन
1	Pratap Sarkar	742237, Construction Manager - BHEL site office Unit-V Sagardighi Thermal Power Project P.O. Manigram, District - Murshidabad, PIN:742237, West Bengal, India	1	999

**As Per SI. No. C 4 Of BOQ At Page 1 Of Technical Specification I.e. SS EQUAL TEE - FOR EACH TAG**

**(Minimum 85% Local Content required for qualifying as Class 1 Local Supplier)**

Brand Type/ब्रांड का प्रकार	Unbranded
-----------------------------	-----------

**Technical Specifications/तकनीकी विशिष्टियाँ**

<b>Specification Document</b>	<a href="#">View File</a>
<b>BOQ Detail Document</b>	<a href="#">View File</a>

Advisory-Please refer attached BOQ document for detailed consignee list and delivery period.

**Consignees/Reporting Officer/परेषिती/रिपोर्टिंग अधिकारी and/ तथा Quantity/मात्रा**

S.No./क्र. सं.	Consignee Reporting/Officer/ परेषिती/रिपोर्टिंग अधिकारी	Address/पता	Quantity/मात्रा	Delivery Days/डिलीवरी के दिन
1	Pratap Sarkar	742237, Construction Manager - BHEL site office Unit-V Sagardighi Thermal Power Project P.O. Manigram, District - Murshidabad, PIN:742237, West Bengal, India	1	999

**As Per SI. No. C 5 Of BOQ At Page 1 Of Technical Specification I.e. SS 1,2 Inch NPT M X 1,4 Inch OD TUBE CONNECTOR- FOR EACH TAG**

**(Minimum 85% Local Content required for qualifying as Class 1 Local Supplier)**

Brand Type/ब्रांड का प्रकार	Unbranded
-----------------------------	-----------

**Technical Specifications/तकनीकी विशिष्टियाँ**

<b>Specification Document</b>	<a href="#">View File</a>
<b>BOQ Detail Document</b>	<a href="#">View File</a>

Advisory-Please refer attached BOQ document for detailed consignee list and delivery period.

**Consignees/Reporting Officer/परेषिती/रिपोर्टिंग अधिकारी and/ तथा Quantity/मात्र**

<b>S.No./क्र. सं.</b>	<b>Consignee Reporting/Officer/ परेषिती/रिपोर्टिंग अधिकारी</b>	<b>Address/पता</b>	<b>Quantity/मात्र</b>	<b>Delivery Days/डिलीवरी के दिन</b>
1	Pratap Sarkar	742237, Construction Manager - BHEL site office Unit-V Sagardighi Thermal Power Project P.O. Manigram, District - Murshidabad, PIN:742237, West Bengal, India	1	999

**As Per SI. No. D Of BOQ At Page 1 Of Technical Specification I.e. VALVE DIAGNOSTIC AND CONFIGURATION SOFTWARE FOR ALL TAGS**

**(Minimum 85% Local Content required for qualifying as Class 1 Local Supplier)**

Brand Type/ब्रांड का प्रकार	Unbranded
-----------------------------	-----------

**Technical Specifications/तकनीकी विशिष्टियाँ**

<b>Specification Document</b>	<a href="#">View File</a>
<b>BOQ Detail Document</b>	<a href="#">View File</a>

Advisory-Please refer attached BOQ document for detailed consignee list and delivery period.

**Consignees/Reporting Officer/परेषिती/रिपोर्टिंग अधिकारी and/ तथा Quantity/मात्र**

S.No./क्र. सं.	Consignee Reporting/Officer/ परेषिती/रिपोर्टिंग अधिकारी	Address/पता	Quantity/मात्रा	Delivery Days/डिलीवरी के दिन
1	Pratap Sarkar	742237, Construction Manager - BHEL site office Unit-V Sagardighi Thermal Power Project P.O. Manigram, District - Murshidabad, PIN:742237, West Bengal, India	1	999

**As Per SI. No. E Of BOQ At Page 1 Of Technical Specification I.e. CV TEST CHARGE**

**(Minimum 85% Local Content required for qualifying as Class 1 Local Supplier)**

Brand Type/ब्रांड का प्रकार	Unbranded
-----------------------------	-----------

**Technical Specifications/तकनीकी विशिष्टियाँ**

<b>Specification Document</b>	<a href="#">View File</a>
<b>BOQ Detail Document</b>	<a href="#">View File</a>

Advisory-Please refer attached BOQ document for detailed consignee list and delivery period.

**Consignees/Reporting Officer/परेषिती/रिपोर्टिंग अधिकारी and/ तथा Quantity/मात्रा**

S.No./क्र. सं.	Consignee Reporting/Officer/ परेषिती/रिपोर्टिंग अधिकारी	Address/पता	Quantity/मात्रा	Delivery Days/डिलीवरी के दिन
1	Pratap Sarkar	742237, Construction Manager - BHEL site office Unit-V Sagardighi Thermal Power Project P.O. Manigram, District - Murshidabad, PIN:742237, West Bengal, India	1	999

**COMMISSIONING SPARES - As Per SI. No. 1 Of BOQ At Page 1 Of Technical Specification I.e. Gaskets**

**(Minimum 85% Local Content required for qualifying as Class 1 Local Supplier)**

Brand Type/ब्रांड का प्रकार	Unbranded
-----------------------------	-----------

**Technical Specifications/तकनीकी विशिष्टियाँ**

<b>Specification Document</b>	<a href="#">View File</a>
<b>BOQ Detail Document</b>	<a href="#">View File</a>

Advisory-Please refer attached BOQ document for detailed consignee list and delivery period.

**Consignees/Reporting Officer/परेषिती/रिपोर्टिंग अधिकारी and/ तथा Quantity/मात्र**

<b>S.No./क्र. सं.</b>	<b>Consignee Reporting/Officer/ परेषिती/रिपोर्टिंग अधिकारी</b>	<b>Address/पता</b>	<b>Quantity/मात्र</b>	<b>Delivery Days/डिलीवरी के दिन</b>
1	Pratap Sarkar	742237, Construction Manager - BHEL site office Unit-V Sagardighi Thermal Power Project P.O. Manigram, District - Murshidabad, PIN:742237, West Bengal, India	1	999

**COMMISSIONING SPARES - As Per Sl. No. 2 Of BOQ At Page 1 Of Technical Specification I.e. Gland Packing**

**(Minimum 85% Local Content required for qualifying as Class 1 Local Supplier)**

Brand Type/ब्रांड का प्रकार	Unbranded
-----------------------------	-----------

**Technical Specifications/तकनीकी विशिष्टियाँ**

<b>Specification Document</b>	<a href="#">View File</a>
<b>BOQ Detail Document</b>	<a href="#">View File</a>

Advisory-Please refer attached BOQ document for detailed consignee list and delivery period.

**Consignees/Reporting Officer/परेषिती/रिपोर्टिंग अधिकारी and/ तथा Quantity/मात्र**

S.No./क्र. सं.	Consignee Reporting/Officer/ परेषिती/रिपोर्टिंग अधिकारी	Address/पता	Quantity/मात्रा	Delivery Days/डिलीवरी के दिन
1	Pratap Sarkar	742237, Construction Manager - BHEL site office Unit-V Sagardighi Thermal Power Project P.O. Manigram, District - Murshidabad, PIN:742237, West Bengal, India	1	999

**MANDATORY SPARES - As Per SI. No. 1 Of BOQ At Page 1 Of Technical Specification I.e. Bonnet Seal**

**(Minimum 85% Local Content required for qualifying as Class 1 Local Supplier)**

Brand Type/ब्रांड का प्रकार	Unbranded
-----------------------------	-----------

**Technical Specifications/तकनीकी विशिष्टियाँ**

<b>Specification Document</b>	<a href="#">View File</a>
<b>BOQ Detail Document</b>	<a href="#">View File</a>

Advisory-Please refer attached BOQ document for detailed consignee list and delivery period.

**Consignees/Reporting Officer/परेषिती/रिपोर्टिंग अधिकारी and/ तथा Quantity/मात्रा**

S.No./क्र. सं.	Consignee Reporting/Officer/ परेषिती/रिपोर्टिंग अधिकारी	Address/पता	Quantity/मात्रा	Delivery Days/डिलीवरी के दिन
1	Pratap Sarkar	742237, Construction Manager - BHEL site office Unit-V Sagardighi Thermal Power Project P.O. Manigram, District - Murshidabad, PIN:742237, West Bengal, India	1	999

**MANDATORY SPARES - As Per SI. No. 2 Of BOQ At Page 1 Of Technical Specification I.e. Gland Packing**

**(Minimum 85% Local Content required for qualifying as Class 1 Local Supplier)**

Brand Type/ब्रांड का प्रकार	Unbranded
-----------------------------	-----------

**Technical Specifications/तकनीकी विशिष्टियाँ**

<b>Specification Document</b>	<a href="#">View File</a>
<b>BOQ Detail Document</b>	<a href="#">View File</a>

Advisory-Please refer attached BOQ document for detailed consignee list and delivery period.

**Consignees/Reporting Officer/परेषिती/रिपोर्टिंग अधिकारी and/ तथा Quantity/मात्र**

<b>S.No./क्र. सं.</b>	<b>Consignee Reporting/Officer/ परेषिती/रिपोर्टिंग अधिकारी</b>	<b>Address/पता</b>	<b>Quantity/मात्र</b>	<b>Delivery Days/डिलीवरी के दिन</b>
1	Pratap Sarkar	742237, Construction Manager - BHEL site office Unit-V Sagardighi Thermal Power Project P.O. Manigram, District - Murshidabad, PIN:742237, West Bengal, India	1	999

**MANDATORY SPARES - As Per Sl. No. 3 Of BOQ At Page 1 Of Technical Specification I.e. Plug Seat Cage Stem Etc**

**(Minimum 85% Local Content required for qualifying as Class 1 Local Supplier)**

Brand Type/ब्रांड का प्रकार	Unbranded
-----------------------------	-----------

**Technical Specifications/तकनीकी विशिष्टियाँ**

<b>Specification Document</b>	<a href="#">View File</a>
<b>BOQ Detail Document</b>	<a href="#">View File</a>

Advisory-Please refer attached BOQ document for detailed consignee list and delivery period.

**Consignees/Reporting Officer/परेषिती/रिपोर्टिंग अधिकारी and/ तथा Quantity/मात्र**

S.No./क्र. सं.	Consignee Reporting/Officer/ परेषिती/रिपोर्टिंग अधिकारी	Address/पता	Quantity/मात्रा	Delivery Days/डिलीवरी के दिन
1	Pratap Sarkar	742237, Construction Manager - BHEL site office Unit-V Sagardighi Thermal Power Project P.O. Manigram, District - Murshidabad, PIN:742237, West Bengal, India	1	999

**MANDATORY SPARES - As Per SI. No. 4 Of BOQ At Page 1 Of Technical Specification I.e. Retainer Ring Seal Ring Etc**

**(Minimum 85% Local Content required for qualifying as Class 1 Local Supplier)**

Brand Type/ब्रांड का प्रकार	Unbranded
-----------------------------	-----------

**Technical Specifications/तकनीकी विशिष्टियाँ**

<b>Specification Document</b>	<a href="#">View File</a>
<b>BOQ Detail Document</b>	<a href="#">View File</a>

Advisory-Please refer attached BOQ document for detailed consignee list and delivery period.

**Consignees/Reporting Officer/परेषिती/रिपोर्टिंग अधिकारी and/ तथा Quantity/मात्रा**

S.No./क्र. सं.	Consignee Reporting/Officer/ परेषिती/रिपोर्टिंग अधिकारी	Address/पता	Quantity/मात्रा	Delivery Days/डिलीवरी के दिन
1	Pratap Sarkar	742237, Construction Manager - BHEL site office Unit-V Sagardighi Thermal Power Project P.O. Manigram, District - Murshidabad, PIN:742237, West Bengal, India	1	999

**MANDATORY SPARES - As Per SI. No. 5 Of BOQ At Page 1 Of Technical Specification I.e. Actuator Seal Kit For Pneumatic Cylinder**

**(Minimum 85% Local Content required for qualifying as Class 1 Local Supplier)**

Brand Type/ब्रांड का प्रकार	Unbranded
-----------------------------	-----------

**Technical Specifications/तकनीकी विशिष्टियाँ**

<b>Specification Document</b>	<a href="#">View File</a>
<b>BOQ Detail Document</b>	<a href="#">View File</a>

Advisory-Please refer attached BOQ document for detailed consignee list and delivery period.

**Consignees/Reporting Officer/परेषिती/रिपोर्टिंग अधिकारी and/ तथा Quantity/मात्र**

<b>S.No./क्र. सं.</b>	<b>Consignee Reporting/Officer/ परेषिती/रिपोर्टिंग अधिकारी</b>	<b>Address/पता</b>	<b>Quantity/मात्र</b>	<b>Delivery Days/डिलीवरी के दिन</b>
1	Pratap Sarkar	742237, Construction Manager - BHEL site office Unit-V Sagardighi Thermal Power Project P.O. Manigram, District - Murshidabad, PIN:742237, West Bengal, India	2	999

**MANDATORY SPARES - As Per Sl. No. 6 Of BOQ At Page 1 Of Technical Specification I.e. Smart Positioner Of The Valve**

**(Minimum 85% Local Content required for qualifying as Class 1 Local Supplier)**

Brand Type/ब्रांड का प्रकार	Unbranded
-----------------------------	-----------

**Technical Specifications/तकनीकी विशिष्टियाँ**

<b>Specification Document</b>	<a href="#">View File</a>
<b>BOQ Detail Document</b>	<a href="#">View File</a>

Advisory-Please refer attached BOQ document for detailed consignee list and delivery period.

**Consignees/Reporting Officer/परेषिती/रिपोर्टिंग अधिकारी and/ तथा Quantity/मात्र**

S.No./क्र. सं.	Consignee Reporting/Officer/ परेषिती/रिपोर्टिंग अधिकारी	Address/पता	Quantity/मात्रा	Delivery Days/डिलीवरी के दिन
1	Pratap Sarkar	742237, Construction Manager - BHEL site office Unit-V Sagardighi Thermal Power Project P.O. Manigram, District - Murshidabad, PIN:742237, West Bengal, India	1	999

**MANDATORY SPARES - As Per SI. No. 7 Of BOQ At Page 1 Of Technical Specification I.e. Position Feedback Transmitter - Applicable If It Is Not Integral With The Smart Positioner**

(Minimum 85% Local Content required for qualifying as Class 1 Local Supplier)

Brand Type/ब्रांड का प्रकार	Unbranded
-----------------------------	-----------

**Technical Specifications/तकनीकी विशिष्टियाँ**

<b>Specification Document</b>	<a href="#">View File</a>
<b>BOQ Detail Document</b>	<a href="#">View File</a>

Advisory-Please refer attached BOQ document for detailed consignee list and delivery period.

**Consignees/Reporting Officer/परेषिती/रिपोर्टिंग अधिकारी and/ तथा Quantity/मात्रा**

S.No./क्र. सं.	Consignee Reporting/Officer/ परेषिती/रिपोर्टिंग अधिकारी	Address/पता	Quantity/मात्रा	Delivery Days/डिलीवरी के दिन
1	Pratap Sarkar	742237, Construction Manager - BHEL site office Unit-V Sagardighi Thermal Power Project P.O. Manigram, District - Murshidabad, PIN:742237, West Bengal, India	1	999

**Buyer Added Bid Specific Terms and Conditions/क्रेता द्वारा जोड़ी गई बिड की विशेष शर्तें**

1. Generic

OPTION CLAUSE: The Purchaser reserves the right to increase or decrease the quantity to be ordered up to 25 percent of bid quantity at the time of placement of contract. The purchaser also reserves the right to increase the ordered quantity by up to 25% of the contracted quantity during the currency of the contract at the contracted rates. Bidders are bound to accept the orders accordingly.

## 2. **Inspection**

**Nominated Inspection Agency:** On behalf of the Buyer organization, any one of the following Inspection Agency would be conducting inspection of stores before acceptance:  
Pre-dispatch Inspection at Seller Premises (applicable only if pre-dispatch inspection clause has been selected in ATC): YES  
Post Receipt Inspection at consignee site before acceptance of stores: NA

## 3. **Certificates**

Bidder's offer is liable to be rejected if they don't upload any of the certificates / documents sought in the Bid document, ATC and Corrigendum if any.

## 4. **Generic**

Bidders are advised to check applicable GST on their own before quoting. Buyer will not take any responsibility in this regards. GST reimbursement will be as per actuals or as per applicable rates (whichever is lower), subject to the maximum of quoted GST %.

## 5. **Buyer Added Bid Specific ATC**

Buyer uploaded ATC document [Click here to view the file.](#)

## 6. **Generic**

Data Sheet of the product(s) offered in the bid, are to be uploaded along with the bid documents. Buyers can match and verify the Data Sheet with the product specifications offered. In case of any unexplained mismatch of technical parameters, the bid is liable for rejection.

## 7. **Generic**

While generating invoice in GeM portal, the seller must upload scanned copy of GST invoice and the screenshot of GST portal confirming payment of GST.

## **Disclaimer/अस्वीकरण**

The additional terms and conditions have been incorporated by the Buyer after approval of the Competent Authority in Buyer Organization, whereby Buyer organization is solely responsible for the impact of these clauses on the bidding process, its outcome, and consequences thereof including any eccentricity / restriction arising in the bidding process due to these ATCs and due to modification of technical specifications and / or terms and conditions governing the bid. Any clause(s) incorporated by the Buyer regarding following shall be treated as null and void and would not be considered as part of bid:-

1. Definition of Class I and Class II suppliers in the bid not in line with the extant Order / Office Memorandum issued by DPIIT in this regard.
2. Seeking EMD submission from bidder(s), including via Additional Terms & Conditions, in contravention to exemption provided to such sellers under GeM GTC.
3. Publishing Custom / BOQ bids for items for which regular GeM categories are available without any Category item bunched with it.
4. Creating BoQ bid for single item.
5. Mentioning specific Brand or Make or Model or Manufacturer or Dealer name.
6. Mandating submission of documents in physical form as a pre-requisite to qualify bidders.
7. Floating / creation of work contracts as Custom Bids in Services.
8. Seeking sample with bid or approval of samples during bid evaluation process.

9. Mandating foreign / international certifications even in case of existence of Indian Standards without specifying equivalent Indian Certification / standards.
10. Seeking experience from specific organization / department / institute only or from foreign / export experience.
11. Creating bid for items from irrelevant categories.
12. Incorporating any clause against the MSME policy and Preference to Make in India Policy.
13. Reference of conditions published on any external site or reference to external documents/clauses.
14. Asking for any Tender fee / Bid Participation fee / Auction fee in case of Bids / Forward Auction, as the case may be.

Further, if any seller has any objection/grievance against these additional clauses or otherwise on any aspect of this bid, they can raise their representation against the same by using the Representation window provided in the bid details field in Seller dashboard after logging in as a seller within 4 days of bid publication on GeM. Buyer is duty bound to reply to all such representations and would not be allowed to open bids if he fails to reply to such representations.

[This Bid is also governed by the General Terms and Conditions/ यह बिड सामान्य शर्तों के अंतर्गत भी शासित है](#)

In terms of GeM GTC clause 26 regarding Restrictions on procurement from a bidder of a country which shares a land border with India, any bidder from a country which shares a land border with India will be eligible to bid in this tender only if the bidder is registered with the Competent Authority. While participating in bid, Bidder has to undertake compliance of this and any false declaration and non-compliance of this would be a ground for immediate termination of the contract and further legal action in accordance with the laws./जेम की सामान्य शर्तों के खंड 26 के संदर्भ में भारत के साथ भूमि सीमा साझा करने वाले देश के बिडर से खरीद पर प्रतिबंध के संबंध में भारत के साथ भूमि सीमा साझा करने वाले देश का कोई भी बिडर इस निविदा में बिड देने के लिए तभी पात्र होगा जब वह बिड देने वाला सक्षम प्राधिकारी के पास पंजीकृत हो। बिड में भाग लेते समय बिडर को इसका अनुपालन करना होगा और कोई भी गलत घोषणा किए जाने व इसका अनुपालन न करने पर अनुबंध को तत्काल समाप्त करने और कानून के अनुसार आगे की कानूनी कार्रवाई का आधार होगा।

**---Thank You/धन्यवाद---**

**ADDITIONAL TERMS & CONDITIONS (ATC)**

**The below mentioned terms and conditions shall supersede the terms and conditions mentioned elsewhere in tender document :**

1	<b>Terms Of Payment</b>	
	<b>a) Supply (Main + Mandatory Spares)</b>	<p>As per clause no. 12 of GTC on GeM. Supplier has to provide Tax invoice, Packing List, LR/RR, CRAC, Insurance intimation, Guarantee Certificate, E-way bill (as applicable) for payment.</p> <p>Offline payment mode shall be selected. Payment will be released to seller within 90 days for Non-MSME vendors, within 45 days for Micro &amp; Small vendors and 60 days for Medium enterprises (as per MSMED Act). This is in supersession of 10 days' time as provided in clause 12 of GeM GTC).</p>
	<b>b) CV Test</b>	<p>As per clause no. 12 of GTC on GeM. Supplier has to provide Tax invoice, CRAC for payment. Further, 100% payment shall be released after successful completion of the activity on pro rata basis, on Site certification/ certification by engineering as applicable.</p> <p>Offline payment mode shall be selected. Payment will be released to seller within 90 days for Non-MSME vendors, within 45 days for Micro &amp; Small vendors and 60 days for Medium enterprises (as per MSMED Act). This is in supersession of 10 days' time as provided in clause 12 of GeM GTC).</p>
2	<b>Terms Of Delivery</b>	<p>F.O.R Dispatch station. However, loading &amp; transit insurance shall be in the scope of Seller and unloading of items at delivery point shall be in the scope of BHEL. Bidder to quote prices accordingly.</p>
3	<b>Delivery</b>	<p>Delivery schedule shall be as per Annexure-A of technical specification (at page no. 2 of technical specification).</p> <p>Delivery period for sake of GeM bid shall be chosen as 999 days (maximum allowable delivery time) from PO date. However, this period shall not be considered for Delivery and Delay analysis purpose.</p> <p>For Delivery and delay analysis purpose, delivery schedule mentioned in Annexure-A (at page no. 2 of technical specification) shall be considered.</p>
4	<b>Guarantee Terms</b>	<p>As per Cl. No. 10 of GTC on GeM for the bid (refer GeM GTC). However time period shall be as under:</p> <p><b>For Main Supply :</b> Guarantee &amp; Warrantee time period shall be 18 months from the date of last supply in the Main Supply scope.</p> <p><b>For Mandatory Spares :</b> Guarantee &amp; Warrantee time period shall be 18 months from the date of last supply in the Mandatory Spares Supply scope.</p>
5.1	<b>Quantity Variation</b>	<p>+10%, (Same shall supersede the quantity variation mentioned elsewhere in bid).</p>
5.2	<b>Special terms and conditions</b>	<ol style="list-style-type: none"><li>1. Material shall be dispatched only after issuance of MDCC by BHEL.</li><li>2. Advance intimation of dispatch by bidder shall be given, to PEM and Insurance agency/Site.</li><li>3. Bank Guarantee submission shall be as per cl. No. 7 of GeM GTC with initial validity of 28 Months. Further, extension if any shall be as per GeM Terms.</li></ol>

		However, proportionate value of BG can be reduced on elapse of 2 months from expiry of Guarantee & Warranty period of Main Supply Scope/Mandatory Spares Scope (as applicable).
6.1	Integrity Pact & CIF - Not applicable.	
6.2	<p>This is a conditional tender enquiry. Reverse Auction of a bidder shall be subjected to the following :</p> <ul style="list-style-type: none"> <li>i) Approval of vendor by end customer i.e. (M/s WBPDCCL).</li> <li>ii) Techno-Commercial evaluation by BHEL.</li> <li>iii) Qualification of Technical PQR.</li> <li>iv) Offered item should mandatorily conform to PP-MII order provisions.</li> </ul>	
6.3	This item/package /system falls under the list of items defined in para 3 of ministry of finance guideline dtd. 20.09.2016 (Procurement of items related to Public safety, Health, Critical Security operations & Equipments etc.) & hence criteria of prior experience/Turnover shall be same for all the bidders including start-up/MSME.	
6.4	For this tender, offline payment mode is applicable.	
6.5	<p>Bidders have to note, "For this procurement, the local content to categorize a supplier as a Class I Local Supplier / Class II Local Supplier / Non Local supplier and Purchase preference to Class I local supplier, is as defined in Public Procurement (Preference to Make in India), (PPP-MII) Order 2017 dt. 16/09/2020 issued by DPIIT. In case of subsequent orders issued by the nodal ministry, changing the definition of local content for the items of the NIT, the same shall be applicable even if issued after issue of this NIT, but before opening of Part-II bids against this NIT."</p> <p>Following point to be noted regarding verification of local content: - The local supplier at the time of tender, bidding or solicitation shall be required to provide a certificate w.r.t. minimum local content, in accordance with para 9 of PP-MII order revision dated 16.09.2020.</p> <p>In accordance with para 9 (a) of DPIIT's PP-MII order 2017 revision dated 04/06/2020, Class-I local suppliers" / "Class-II local suppliers" at the time of tender, bidding or solicitation shall be required to indicate percentage of local content and provide self-certification that the item offered meets the local content requirement for the Class-I local supplier" / "Class-II local supplier" as the case may be. They shall also give details of the location(s) at which the local value addition is made.</p> <p>Following may also please be noted by the bidders : <b>Eligibility of Suppliers : Class I Local Supplier</b>, (as per para no. 3(a) of Public Procurement (Preference to Make in India), (PPP-MII) Order 2017 dt. 16/09/2020 issued by DPIIT and subsequent amendments)</p> <p><b>The package is non-divisible in nature.</b></p>	
6.6	Bidders to ensure that Third party / customer issued certificates being submitted as proof of PQR qualification should have verifiable details of document / certificate issuing authority such as name & designation of Issuing Authority and its organisation contact number and e-mail Id etc. In case the same found not available, Purchaser has right to reject such document from evaluation.	

6.7	<p>Bidders to,</p> <ul style="list-style-type: none"> <li>• ensure compliance to Ministry of Power (MoP) Order No. 25-11/6/2018-PG dt. 02/07/2020 &amp; Order No. 11/05/2018-Coord. dt. 23/07/2020, if applicable.</li> <li>• ensure compliance of Ministry of Finance (MoF) Order (Public Procurement No. 1 &amp; 2) F. No. 6/18/2019/PPD dt. 23/07/2020.</li> <li>• to submit “Model Certificate for Tenders” as per Annexure-III of Ministry of Finance (MoF) Order (Public Procurement No. 1 &amp; 2) F. No. 6/18/2019/PPD dt. 23/07/2020.</li> </ul> <p>Note: Subsequent orders/circulars to be checked and to be complied.</p>
6.8	<p>Due to COVID-19 pandemic condition prevailing in the country, BHEL/PEM may go for Remote Inspection of Offered items, if required. Vendors are requested to be equipped with the facilities/gadgets as indicated in the guidelines mentioned in "<a href="https://pem.bhel.com/Documents/VendorSection/Vendor/Guidelines.pdf">https://pem.bhel.com/Documents/VendorSection/Vendor/Guidelines.pdf</a>" to take up the inspection REMOTELY.</p> <p>Inspection call to be raised by bidder on BHEL CQIR portal (details shall be shared at the of execution of order) and Inspection agency shall attend at the inspection within seven (07) days of the date on which the material is notified as being ready. In case of delay in witnessing of inspection beyond stipulated time (i.e. 7 days from the date on which the material is notified as being ready), by BHEL arising due to reasons not attributable to vendor, BHEL will extend the delivery period for such delay in carrying out inspection. If BHEL is not able to witness inspection up to 15 days then in addition to delay beyond stipulated period, extension in delivery time of 07 days for arranging fresh inspection will be given.</p> <p>When the tests have been satisfactorily completed at Seller/ Contractor's works, the Inspection Agency shall issue an inspection report that effect within seven (07) days after completion of the tests, but if the tests were not witnessed by the Inspection Agency or his representative, the material acceptance report would be issued within seven (07) days after receipt of the test certificates by the Purchaser.</p> <p>Purchaser will issue MDCC to the Seller/ Contractor within 7 days based on inspection report/ test certificates/Certificate of Conformance as applicable. In case of delay in issuance of MDCC beyond 7 days stipulated time (i.e. from the date of successful inspection report), by BHEL arising due to reasons not attributable to vendor, BHEL will extend the delivery period for such delay in issuing MDCC. If BHEL is not able to issue MDCC up to 15 days then in addition to delay beyond stipulated period, 7 days’ additional time shall be given to vendor to facilitate the vendor for arranging logistics arrangements.</p>
6.9	<p>The Bidder declares that they will not enter into any illegal or undisclosed agreement or understanding, whether formal or informal with other Bidder(s). This applies in particular to prices, specifications, certifications, subsidiary contracts, submission or non-submission of bids or any other actions to restrict competitiveness or to introduce cartelization in the bidding process. In case, the bidder is found having indulged in above activities, suitable action shall be taken by BHEL as per extant policies/guideline.</p>
6.10	<p>Bidders to inform freight /GST percentage for all the items as part of un-priced bid to be submitted along with their Techno-Commercial offer. However, negotiation/RA shall be on Total Evaluation (F.O.R as per GeM) price only as per GeM logs. Detailed Price Break up shall be reverse calculated based on freight/GST percentage furnished by bidder for Order Placement.</p>
6.11	<p>Bidder has to provide the details as per TECHNICAL PQR (<b>at page no. 7 of technical specification</b>) in its offer and has to note that bids of only those bidders shall be evaluated who meet the Technical Pre-Qualifying requirements. Above terms for PQR shall prevail in conflict (if any).</p>

6.12	PVC clause – Not applicable.
6.13	<b>For bidders (who are not registered with BHEL-PEM)</b> - For registration in BHEL PEM- Online registration portal is operational, Non-registered Vendors who wish to apply for registration in BHEL-PEM can apply through Online Registration Portal available at <a href="http://www.pem.bhel.com">www.pem.bhel.com</a> - vendor section - Online Supplier Registration. All credentials and/or documents duly signed and stamped related to registration can be uploaded on the website and submit the application for registration. However, registration of suppliers is not mandatory in case of open tender

#### 6.14 Dispatch Markings: -

Each box shall be marked with Capital Letters in “Red” indicating: Main Supply OR Commissioning spare OR Mandatory Spare for 1X 660 MW SAGARDIGHI TPP EXTENSION UNIT 5, P.O. Manigram, District - Murshidabad, PIN:742237, West Bengal, India Each package/Drum delivered under the Contract shall be marked by Supplier as per details listed below and such marking must be distinct and in English Language (all previous irrelevant markings being carefully obliterated) for purposes of identification.

Each and every box(package) shall be marked with following: -

- 1) Name and address of the consignee.
- 2) Project Reference.
- 3) Name of Supplier
- 4) P.O. reference no. along with package name.
- 5) Packing No. (1/10, 2/10, 3/10 when there are 10 packages for one consignment)
- 6) The Gross weight and net weight of the package.

Besides above necessary, packing shall bear a special marking "TOP", "BOTTOM", "DO NOT TURN OVER", "DEEP DRY", "HANDLE WITH CARE", etc.

#### **IMPORTANT**

Two copies of respective standard manufacturer's erection instruction /operation manual shall be provided for immediate reference by BHEL site.

The Copy of complete Packing list for the consignment must be put inside the Box/Boxes.

12 copies of supplier's Erection/ Instruction manuals to be given to the BHEL, PEM, PPEI Noida and 3 copies to BHEL, PSER, Sagardighi site within 30 days of dispatch for handing over to Customer/BHEL site.

Items like pumps, Valves, Hoists, Cranes, etc. shall essentially have O&M Manuals and E&C guidelines duly enclosed in the packing box.

**Commissioning Spares:** - The commissioning spares shall be properly packed separately in separate box and each spare shall be properly tagged giving details i.e. dispatch (to match the description given in the packing slip) to facilitate their proper identification. One Copy of Packing list must be put inside the Box.

**Mandatory Spares:** - Supplies of spares will be separate from main supply and separate manufacturing clearance shall be given for mandatory spares. The Mandatory spares shall be properly packed separately in separate boxes & boxes should be painted in red indicating Mandatory Spares in bold letters and each spare

shall be properly tagged giving details i.e. item number of the equipment in line with the WBPDC approved BBU for Mandatory spares & Number per item (to match the description given in the packing slip) to facilitate their proper identification by ultimate customer M/s WBPDC. One Copy of Packing List must be put inside the BOX along with Manufacturing drawing no. reference, Catalogue reference etc.

Note :- MDCC for mandatory Spares shall be issued only after receipt of detailed list of mandatory spares & photographs before final packing clearly showing mandatory spares with due tagging as per packing list ( to be sent over mail/CD). Separate dispatch clearance will be issued for the mandatory spares in line with availability of customer's stores at site.

#### **6.15. Liquidated Damages :-**

a) **Main Supply & Commissioning Spares :-** Purchaser reserves the right to recover from the Seller/ Contractor, as agreed liquidated damages and not by way of penalty, a sum equivalent to half (½) percent and applicable GST thereon, of the total main supply & commissioning spares contract price excluding GST per week or part thereof, subject to a maximum of ten(10) percent of the total main supply & commissioning Spares contract price excluding GST, if the Seller/ Contractor fails to deliver any part of the ordered goods/stores within the period stipulated in the Order/ Contract.

#### **b) LD on mandatory spares portion : -**

Purchaser reserves the right to recover from the Seller/ Contractor, as agreed liquidated damages and not by way of penalty, a sum equivalent to half (½) percent and applicable GST thereon, of the total Mandatory Spares contract price excluding GST per week or part thereof, subject to a maximum of ten (10) percent of the total Mandatory Spares contract price excluding GST, if the Seller/ Contractor fails to deliver any part of the ordered Mandatory Spares goods/stores within the period stipulated in the Order/ Contract.

#### **NOTE:**

i. LR/RR date for indigenous supplies (Bill of Lading/AWB for Foreign supplies) shall be treated as the date of dispatch for levying LD. However, if receipted LR date for indigenous supply is beyond 30 days for FTL/ 45 days for PTL from the date of LR (PTL to be clearly mentioned in LR), such excess period shall be considered for LD purpose irrespective of dispatch date. Import General Manifest (IGM)/Bill of entry date (whichever is earlier), for foreign supplies, is beyond 90 days from the date of Bill of Lading/AWB, such excess period shall be considered for LD purpose irrespective of dispatch date.

ii. In case of any amendment/ revision, LD shall be linked to the amended/ revised contract value and delivery date(s).

iii. If Order/ Contract involves two or more Units/ Sets/ Lots/ Stages, then Liquidated Damages shall be levied on order/ contract value excluding GST of the delayed Unit/ Set/ Lot/ Stage, provided delivery stipulated in the Order/ Contract is Unit/ Set/ Lot/Stage wise, however total LD amount shall be limited to 10% of total order/ amended order value excluding GST of delayed Unit/ Set/ Lot/Stage. Any subsequent lot released (not envisaged in original contract) due to increase in quantity within permissible quantity variation shall be treated as separate lot for the purpose of LD.

iv. The sum specified above is not a penalty but a genuine pre-estimate of the loss/ damage which will be suffered by purchaser on account of delay on the part of the Contractor/Seller and the said amount will be deductible without proof of actual loss or damage caused by such delay

#### **6.16. Risk & Cost Purchase :- As per page no. 3-6 of technical specification.**

**6.17.** The Bidder declares that they will not enter into any illegal or undisclosed agreement or understanding, whether formal or informal with other Bidder(s). This applies in particular to prices, specifications, certifications, subsidiary contracts, submission or non-submission of bids or any other actions to restrict competitiveness or to introduce cartelization in the bidding process. In case, the Bidder is found having indulged in above activities, suitable action shall be taken by BHEL as per extant policies/ guidelines.

**6.18.** In course of evaluation, if more than one bidder happens to occupy L-1 status, effective L-1 will be decided by soliciting discounts from the respective bidders. In case more than one bidder happens to occupy L-1 status even after soliciting discounts, the L1 bidder shall be decided by a toss / draw of lots, in the presence of respective bidder(s) or their representative(s). Ranking will be done accordingly. BHEL's decision in such situation shall be final and binding.

**6.19.** Terms and conditions mentioned at **page no. 72 of technical specification document** i.e. "Instructions to Packing List" is applicable and to be ensured for this package necessarily.

**6.20.** Evaluation will be done on L1 (Total cost to BHEL basis). Incomplete offer or part offer of NIT BOM/BOQ shall be summarily rejected.

**6.21.** GeM has the functionality to quote Single Unit Price (F.O.R) for each item. Bidders to furnish applicable Freight & GST % w.r.t. Ex Works included in Single quoted (F.O.R) prices before Reverse Auction.

**6.22.** Bidder has to provide the details as per TECHNICAL PQR (attached with Specifications of product catalogue) in its offer and has to note that bids of only those bidders shall be evaluated who meet the Technical Pre-Qualifying requirements'. The terms of technical PQR shall prevail in conflict (if any).

**6.23.** Bidder has to provide the details as per TECHNICAL PQR (**at page no. 7 of technical specification document**) in its offer and has to note that bids of only those bidders shall be evaluated who meet the Technical Pre-Qualifying requirements'. The terms of technical PQR shall prevail in conflict (if any).

**6.24.** For recognition of dispatch, vendor to submit following documents to BHEL by e-mail/ fax immediately on dispatch: - GST compliant invoice, LR for Indian Vendors (indicating Invoice No., no. of boxes, PTL (if applicable) etc.) / Bill of Lading or AWB for foreign vendor, Packing List (Must be indicating No. of boxes, Packing size, Gross weight and net weight of each package, Contents of the package with cross reference to BoM item code no. or item serial no. and Quantity of each item separately), Insurance Intimation to underwriter through email/fax, Dispatch Clearance.

**6.30** Bidders to note item code, description, unit, Qty. and foot notes also at BOQ placed at **page no. 1 of technical specification** as same are applicable for this tender.

**6.40 BOQ Related :** - Bidders to note that item title at :- (a) Sl. no. 2 of Bid BOQ is "1/4 " SS TUBING (25 METER FOR EACH TAG)" and (b) Sl. no. 7 of Bid BOQ is " SS 1/2 " NPT(M) X 1/4 " OD TUBE CONNECTOR- FOR EACH TAG".

**ANNEXURE-I : BILL OF QUANTITY**

**MAIN SUPPLY : CONTROL VALVES COMPLETE WITH POSITIONER AND ALL ACCESSORIES MOUNTED, TUBED AND TERMINATED ON JB**

SI. NO.	TAG NO	DESCRIPTION	QTY. FOR 1 UNIT	UOM
[A]	FDV-14	LOW LOAD FEED CONTROL VALVE	1	NO.
[B]	1/4 " SS TUBING (25 METER FOR EACH TAG)		25	METER
[C]	SS FITTINGS- FOR EACH TAG			
1	SS FITTINGS for connection to Air Filter Regulator- FOR EACH TAG		1	LOT
2	SS FITTINGS for connection to Air Lock Relay- FOR EACH TAG		1	LOT
3	SS FITTINGS for connection to IA Header Isolation Valve - FOR EACH TAG		1	LOT
4	SS EQUAL TEE - FOR EACH TAG		1	LOT
5	SS 1/2 " NPT(M) X 1/4 " OD TUBE CONNECTOR- FOR EACH TAG		1	LOT
[D]	VALVE DIAGNOSTIC AND CONFIGURATION SOFTWARE (FOR ALL TAGS)		1	LOT
[E]	CV TEST CHARGE		1	NO.

**LIST OF COMMISSIONING SPARES :**

SI. NO.	ITEM DESCRIPTION	QUANTITY PER UNIT
1	Gaskets	One(1) set with each control valve tag
2	Gland Packing	One(1) set with each control valve tag

**LIST OF MANDATORY SPARES :**

SI. NO.	ITEM DESCRIPTION	QUANTITY PER UNIT
1	Bonnet Seal	2Set (one set means complete replacement required for one Valve)
2	Gland Packing	3Set (one set means complete replacement required for one Valve)
3	Plug, Seat, Cage, Stem etc.	1Set (one set means complete replacement required for one Valve)
4	Retainer Ring, Seal Ring etc.	1Set (one set means complete replacement required for one Valve)
5	Actuator Seal Kit for Pneumatic Cylinder	2Nos.
6	Smart Positioner of the Valve	1No.
7	Position Feedback Transmitter (applicable if it is not integral with the Smart Positioner)	1No.

**NOTE :**

1. Wherever quantity has been specified as percentage (%), the quantity of mandatory spares to be provided by contractor shall be the specified percentage (%) of the total population of the plant. In case the quantity so calculated happens to be a fraction, the same shall be rounded off to next higher whole number.

2. Wherever the quantities have been indicated for each type, size, thickness, material, radius, range etc., these shall cover all the items supplied and installed and the breakup for these shall be furnished in the bid. In case spares indicated in the list are not applicable to the particular design offered by the bidder, the bidder should offer spares applicable to offered design with quantities generally in line with the approach followed in the above list.

## SAGARDIGHI UNIT 5 - Annexure A :- Delivery Schedule of CONTROL VALVE (FEED CONTROL VALVE)

Sl. No.	Package Code	Package name	Deptt.	BHEL Drawing No	Drawing Title	Primary/Secondary	BHEL Inputs	Drg Sch for Vendors	Standard Delivery Terms for Supply Portion
1	145-04000-A	CONTROL VALVE	C&I	PE-V0-XXX-145-1802	DATA SHEET, CALCULATION, BOQ/BOM, GA DRAWING, EDGE Preparation details & HOOK UP / INSTALLATION DRAWING for Control Valves	Primary		R-0 within 14 days from PO & subsequent revisions incorporating all the BHEL comments within 10 days of comments received from BHEL.	Main Supply :- Within Six (06) months from date of CAT-1 approval of Primary drawing/documents or BHEL manufacturing clearance whichever is later, subjected to drawing/document submission/re-submission schedule as stipulated, in case of any delay in submission/re-submission of Primary drawing/documents, then same shall be reduced from the given delivery period.  Mandatory Spares :- Mandatory Spares shall be supplied within Six (06) months from BHEL Manufacturing Clearance. Separate manufacturing clearance shall be accorded for mandatory spares.
				PE-V0-XXX-145-1803	QAP for Control Valves	Primary			
				PE-V0-XXX-145-1806	O&M MANUAL for Control Valves	Secondary		Within 30 days of issuance of MDCC	

- Notes :**
- The end period specified is for completion of the deliveries. Deliveries to start progressively so as to meet the completion schedule.
  - The delivery conditions specified are for contractual LD purposes, however BHEL may ask for early deliveries without any compensation thereof.
  - Non-applicable drawings shall be decided during bid evaluation of the package.
  - Wherever schedule of drawings/documents submission / re-submission is stipulated in the Technical Specifications, same shall be superseded by delivery specified in NIT.
  - Vendor to start manufacturing activities only after obtaining specific manufacturing clearance from BHEL Purchase group.

## **ANNEXURE R :- RISK & COST PURCHASE**

### **DEFAULT/ BREACH OF CONTRACT, INSOLVENCY AND RISK PURCHASE**

In case of delays (beyond the maximum late delivery period as per LD clause) in supplies, or if there be defective supplies or non-fulfilment of any other terms and conditions of the Contract as enumerated subsequently in this clause, then, without prejudice to its right to recover any expenses, losses or damages to which the Buyer may be put to incur or sustain by reason of the Seller/Contractor's default or breach of Order/Contract or to suspend business dealings with the Seller/Contractor in terms of the Buyers' Guidelines for Suspension of Business Dealings as applicable from time to time, the Buyer shall also be entitled to cancel the Order/ Contract either in whole or portion thereof without compensation to Seller. On the occurrence of any of the acts/omissions mentioned below, the Buyer may if it so desires, procure upon such terms and in such manner as deemed appropriate, plant/ equipment/ stores not so delivered or others of similar description where plant/ equipment/ stores exactly complying with particulars are not, in the opinion of the Buyer (which shall be final), readily procurable, at the risk and cost of the Seller.

The Seller shall be liable to the Buyer for any excess costs incurred thereof and the Seller shall continue the performance of the Order/Contract to the extent not cancelled under the provisions of this clause. The Seller shall on no account be entitled to any gain on such repurchases. If the Bidder does not agree to this Risk Purchase clause, BHEL reserves the right to reject the bid/offer of the Bidder.

The order/contract may be cancelled in whole or part thereof and Risk & Cost Clause in line with terms and conditions of PO/Contract may be invoked by the Buyer in any of the following cases:

- i. If the Seller/Contractor fails to deliver the goods or materials or any installment thereof within the period(s) fixed for such delivery or the Seller's poor progress of the supply/services vis-à-vis delivery/execution timeline as stipulated in the contract, backlog attributable to the Seller including unexecuted portion of supply does not appear to be executable within balance period available;
- ii. delivers goods or materials not of the contracted quality and failing to adhere to the contract specifications/execution methodology;
- iii. withdrawal from or repudiation/abandonment of the supply/services by the Seller before completion as per contract or if the Seller refuses or is unable to supply goods or materials covered by the order/Contract either in whole or in part or otherwise fails to perform the Order/Contract.

- iv. Non supply by the Seller within scheduled completion/delivery period as per contract or as extended from time to time for reasons attributable to the Seller;
- v. Termination of Contract on account of any other reason(s) attributable to the Seller.
- vi. Assignment, transfer, sub-letting of Contract without BHEL's written permission resulting in termination of Contract or part thereof by BHEL.
- vii. If the Seller be an individual or a Sole Proprietorship, in the event of death or insanity of the Seller.
- viii. If the Seller/Contractor being an individual or if a partnership firm thereof, shall at any time be adjudged insolvent or shall have a receiving order for administration of his estate made against him or shall take any proceeding for composition under any Insolvency Act for the time being in force or make any assignment of the order/Contract or enter into any arrangement or composition with his creditors or suspend payment or if the firm dissolved under the Partnership Act;
- ix. If the Seller/Contractor being a Company is wound up voluntarily or by order of a Court or a Receiver, Liquidator or Manager on behalf of the debenture holders and creditors is appointed or circumstances have arisen which entitles the Court of debenture holder and creditors to appoint a receiver, liquidator or manager
- x. Non- Compliance to any contractual condition or any other default attributable to the Seller.

Such defaulting vendor/Seller shall not be eligible to participate in re-tendering conducted on account of risk purchase made due to fault of such vendor/Seller.

BHEL's right to go for Risk and Cost, Calculation of Risk and Cost amount & LD, recovery options to BHEL are given in detail in Annexure-V hereto.

## ANNEXURE-V

### (RISK AND COST CLAUSE)

1. BHEL reserves the right to terminate the contract or withdraw portion of work and get it done through other agency, at the risk and cost of the contractor *after due notice of a period of 14 days' by BHEL* in any of the following cases:
  - i) If the Seller/Contractor fails to deliver the goods or materials or any instalment thereof within the period(s) fixed for such delivery or the Seller's poor progress of the supply/ services vis-a-vis delivery/execution timeline as stipulated in the Contract, backlog attributable to seller including unexecuted portion of supply does not appear to be executable within balance available period;
  - ii) Delivers goods or materials not of the contracted quality and failing to adhere to the contract specifications;
  - iii) Withdrawal from or repudiation/ abandonment of the supply/ services by Seller before completion as per contract or if the Seller refuses or is unable to supply goods or materials covered by the Order/Contract either in whole or in part or otherwise fails to perform the Order/Contract;
  - iv) Non-supply by the Seller within scheduled completion/delivery period as per Contract or as extended from time to time, for the reasons attributable to the Seller;
  - v) Termination of Contract on account of any other reason (s) attributable to Seller.
  - vi) Assignment, transfer, subletting of Contract without BHEL's written permission resulting in termination of Contract or part thereof by BHEL.
  - vii) If the Seller be an individual or a sole proprietorship Firm, in the event of the death or insanity of the Seller;
  - viii) If the Seller/Contractor being an individual or if a firm on a partnership thereof, shall at any time, be adjudged insolvent or shall have a receiving order for administration of his estate made against him or shall take any proceeding for composition under any Insolvency Act for the time being in force or make any assignment of the Order/Contract or enter into any arrangement or composition with his creditors or suspend payment or if the firm dissolved under the Partnership Act;
  - ix) If the Seller/Contractor being a company is wound up voluntarily or by order of a Court or a Receiver, Liquidator or Manager on behalf of the debenture holders and creditors is appointed or circumstances shall have arisen which entitles the Court of debenture holder and creditors to appoint a receiver, liquidator or manager;
  - x) Non-compliance to any contractual condition or any other default attributable to Seller.

#### **1.1 Risk & Cost Amount against Balance Work:**

Risk & Cost amount against balance work shall be calculated as follows:

$$\text{Risk \& Cost Amount} = [(A-B) + (A \times H/100)]$$

Where,

A= Value of Balance scope of Work (\*) as per rates of new contract

B= Value of Balance scope of Work (\*) as per rates of old contract being paid to the contractor at the time of termination of contract i.e. inclusive of PVC & ORC, if any.

H = Overhead Factor to be taken as 5

In case (A-B) is less than 0 (zero), value of (A-B) shall be taken as 0 (zero).

#### **1.2 \* Balance scope of work (in case of termination of contract):**

Difference of Contract Quantities and Executed Quantities as on the date of issue of Letter for 'Termination of Contract', shall be taken as balance scope of Work for calculating risk & cost amount.

Contract quantities are the quantities as per original contract. If, Contract has been amended, quantities as per amended Contract shall be considered as Contract Quantities.

Items for which total quantities to be executed have exceeded the Contract Quantities based on drawings issued to contractor from time to time till issue of Termination letter, then for these items total Quantities as per issued drawings would be deemed to be contract quantities.

Substitute/ extra items whose rates have already been approved would form part of contract quantities for this purpose.

Substitute/ extra items which have been executed but rates have not been approved, would also form part of contract quantities for this purpose and rates of such items shall be determined in line with contractual provisions.

However, increase in quantities on account of additional scope in new tender shall not be considered for this purpose.

NOTE: In case portion of work is being withdrawn at risk & cost of contractor instead of termination of contract, contract quantities pertaining to portion of work withdrawn shall be considered as 'Balance scope of work' for calculating Risk & Cost amount.

### **1.3 LD against delay in executed work in case of Termination of Contract:**

LD against delay in executed work shall be calculated in line with LD clause no. 16 of GCC, for the delay attributable to contractor. For limiting the maximum value of LD, contract value shall be taken as Executed Value of work till termination of contract.

Method for calculation of LD against delay in executed work in case of termination of contract" is given below.

- i. Let the time period from scheduled date of start of work till termination of contract excluding the period of Hold (if any) not attributable to contractor = T1
- ii. Let the value of executed work till the time of termination of contract = X
- iii. Let the Total Executable Value of work for which inputs/fronts were made available to contractor and were planned for execution till termination of contract = Y
- iv. Delay in executed work attributable to contractor i.e.  $T2 = [1-(X/Y)] \times T1$
- v. LD shall be calculated in line with LD clause (clause 16) of the Contract for the delay attributable to contractor taking "X" as Contract Value and "T2" as period of delay attributable to contractor.

### **2. Recoveries arising out of Risk & Cost and LD or any other recoveries due from Contractor**

Without prejudice to the other means of recovery of such dues from the Seller recoveries from the Seller on whom risk & cost has been invoked shall be made from the following:

- a) Dues available in the form of Bills payable to seller, SD, BGs against the same contract.
- b) Dues payable to seller against other contracts in the same Region/Unit/ Division of BHEL.
- c) Dues payable to seller against other contracts in the different Region/Unit/ division of BHEL.

*In-case recoveries are not possible with any of the above available options, Legal action shall be initiated for recovery against contractor.*

|

	<b>PRE-QUALIFICATION REQUIREMENTS</b>	PE-PQ-445-145-I001
		REVISION NO. 00 DATE 16.06.2022
		SHEET NO. 1 OF 1

PACKAGE: CONTROL VALVE (FEED CONTROL VALVE) PROJECT: 1x660 MW SAGARDIGHI TPS

1.0	<p>a. Bidder should be Original equipment manufacturer (OEM) for CONTROL VALVE.</p> <p>b. In case bidder is not OEM, evaluation shall be done as following:</p> <ol style="list-style-type: none"> <li>1. If bidder happens to be Indian subsidiaries of foreign OEM, then the credentials of the foreign OEM can also be considered for meeting PQR.</li> <li>2. If bidder happens to be Authorized channel partner or having a valid collaboration agreement / licensing agreement with some other company or being a Joint Venture Company, then the credentials of collaborator / licensing company / Principal company /JV partner can also be considered for meeting PQR as per scope of the work. The scope matrix shall include their respective roles including design vetting, manufacturing of critical component and warranty/guarantee. If bidder(s) qualifies on the basis of credentials of his principal/JV partner/Collaborator etc., then the principal/JV partner/Collaborator shall be responsible for overall design vetting and warranty/guarantee of the package.</li> </ol>
2.0	<p>The Product being offered by the bidder should be in use successfully in power plant or any other industrial application for at least 1 (One) year. Bidder to submit either of following supporting documents for the product (control valve)</p> <p>(i) Minimum valve size = 6"</p> <p>(ii) Minimum pressure rating = ANSI #600</p> <p>(iii) Minimum differential pressure(DP) = 50 Kg/cm2</p> <p>a. Copy of minimum 1 (One) Performance Certificate from end user / customer certifying that product has been running satisfactorily for 1 (One) year from date of commissioning to the date of application. The certificate should clearly indicate date of commissioning, date of issue of certificate and name/designation of the certificate issuer. Copy of purchase order &amp; technical parameter to be attached along with the performance certificate.</p> <p style="text-align: center;">OR</p> <p>b. Copy of repeat orders from minimum 2 (Two) different purchasers. Order received by bidder from same purchaser with a gap of minimum 2 (Two) years shall be considered as repeat order. Copy of technical parameters for each order to be attached.</p>
3.0	<p>Bidder to furnish experience list of last 5 years indicating customer name, purchase order reference, item supplied &amp; year of supply to establish the continuity of business.</p>
4.0	<p>Bidder to submit all documents in English. If documents submitted by bidder are in language other than English, a self-attested English Translated document should also be submitted.</p>

<p>Prepared by:</p> <p><b>SHIKHA THAKUR</b></p> <p><small>Digitally signed by SHIKHA THAKUR DN: cn=SHIKHA THAKUR, o=BHEL, ou=P&amp;M, email=shikha@bhel.in, c=IN Date: 2022.06.17 14:17:33 +05'30'</small></p> <p><b>SHIKHA THAKUR</b> MGR-C&amp;I</p>	<p>Checked by:</p> <p><b>Mayank Kesharwani</b></p> <p><small>Digitally signed by Mayank Kesharwani DN: cn=Mayank Kesharwani, o=BHEL, ou=P&amp;M, email=mkesharwani@bhel.in, c=IN Date: 2022.06.17 14:33:11 +05'30'</small></p> <p><b>MAYANK KESHARWANI</b> SR.MGR-C&amp;I</p>	<p>Approved by:</p> <p><b>Suresh Sharma</b></p> <p><small>Digitally signed by Suresh Sharma DN: cn=Suresh Sharma, o=BHEL, ou=PS-P&amp;M, email=sureshsharma@bhel.in, c=IN Date: 2022.06.17 14:42:30 +05'30'</small></p> <p><b>S.C.SHARMA</b> DGM-C&amp;I</p>
--	---	--

**TECHNICAL SPECIFICATION**  
**FOR**  
**CONTROL VALVE WITH ACCESSORIES**  
**(LOW LOAD FEED CONTROL VALVE)**

**(Pneumatically Operated)**

**SAGARDIGHI THERMAL POWER PROJECT**  
**1 x 660 MW UNIT NO. 5, PHASE – III**

**VOLUME - IIB**

**SECTIONS-A, C & D**

**SPECIFICATION No: PE-TS-445-145-I801A**



**BHARAT HEAVY ELECTRICALS LIMITED**  
**POWER SECTOR**  
**PROJECT ENGINEERING MANAGEMENT DIVISION**  
**NOIDA, INDIA**



## Sagardighi Thermal Power Project

1 x 660 MW Unit No. 5, Phase-III

Technical specification for  
**Control Valve with Accessories - Feed Control Valve**  
(Pneumatically Operated)

SPEC NO.: PE-TS-445-145-I801A

DOCUMENT NO.

VOLUME II B

SECTION

ISSUE NO.

REV. NO. 00

DATE: 23.01.2023

### CONTENTS

#### VOL-II B

SECTION	DESCRIPTION	PAGE NO.
A	Scope of Enquiry	3
C	Specific Technical Requirements	6
	Customer's Specification	11
	Datasheets-A&B (Data sheet no. PES-145-06-DS1-1)	24
	Datasheets-C (Data sheet no. PES-145-06-DS2-1)	28
	Quality Plan	32
	Bill of Quantity - Main Supply	40
	Bill of Quantity – Spares	42
D	Equipment Specification (PES – 145 – 06)	45
	Specification for Smart Positioner (PES – 145 – 06A)	51
	Hook-Up Diagram (PES-145-06B)	55
	Guideline for Packing (PES-145-06C)	58
	Sub Vendor List	60



## Sagardighi Thermal Power Project

1 x 660 MW Unit No. 5, Phase-III

Technical specification for  
**Control Valve with Accessories - Feed Control Valve**  
(Pneumatically Operated)

SPEC NO.: **PE-TS-445-145-I801A**

DOCUMENT NO.

VOLUME II B

SECTION A

ISSUE NO.

REV. NO. 00

DATE: 23.01.2023

# SECTION – A

## SCOPE OF ENQUIRY

	<b>Sagardighi Thermal Power Project</b> 1 x 660 MW Unit No. 5, Phase-III  Technical specification for <b>Control Valve with Accessories - Feed Control Valve</b> (Pneumatically Operated)	SPEC NO.: <b>PE-TS-445-145-I801A</b>	
		DOCUMENT NO.	
		VOLUME	II B
		SECTION	A
		ISSUE NO.	
		REV. NO. 00	DATE: 23.01.2023

## SCOPE OF ENQUIRY

### 1. SCOPE

- 1.1 This specification covers the Design, Manufacture, Inspection and testing at manufacturer's works, proper packing for transportation and delivery to site of the **Control Valves with Pneumatic Actuator along with Accessories, Start-up/Commissioning Spares & Mandatory spares** as mentioned in different sections of this specification for **Sagardighi TPP**, 1 x 660 MW Unit No. 5, Phase-III.
- 1.2 The quality plan enclosed forms the minimum requirement but not limited to be adhered to by the bidder. Bidder to sign and stamp the same and submit along with the offer as an acceptance.
- 1.3 Following signed & stamped documents with company seal to be submitted by bidder.
- a) Complete offer including calculation sheets, catalogues etc.
  - b) Quality Plan
  - c) Datasheet A & B, duly filled
  - d) Schedule of prices & unit prices, inspection schedule
  - e) Schedule of submission of drawings/documents, equipment manufacture, inspection & dispatch.

### 2 GENERAL TECHNICAL INSTRUCTIONS

- 2.1 It is not the intent here to specify all the details of design and manufacture. However, the equipment shall conform in all respects to high standard of design, engineering and workmanship and shall be capable of performing the required duties in a manner acceptable to the customer / consultant, who will interpret the meaning of drawing and specification and shall be entitled to reject any component or material which in his judgment is not in full accordance herewith.
- 2.2 The omission of specific reference to any component / accessory necessary for the proper performance of the equipment shall not relieve the supplier of the responsibility of providing such facilities to complete the supply within the quoted prices.
- 2.3 BHEL' s / Customer' s representatives shall be given access to the shop in which the equipment are being manufactured or tested and all test records shall be made available to them.
- 2.4 The Equipment covered under this specification shall not be dispatched unless the same have been finally inspected, accepted and Material Dispatch Clearance Certificate (MDCC) is issued by BHEL / Customer.

	<b>Sagardighi Thermal Power Project</b> 1 x 660 MW Unit No. 5, Phase-III	SPEC NO.: <b>PE-TS-445-145-I801A</b>	
		DOCUMENT NO.	
	Technical specification for <b>Control Valve with Accessories - Feed Control Valve</b> (Pneumatically Operated)		VOLUME II B
			SECTION C
			ISSUE NO.
			REV. NO. 00

## **SECTION – C**

- **SPECIFIC TECHNICAL REQUIREMENT**
  - **CUSTOMER’S SPECIFICATION**
    - **DATA SHEETS – A & B**
- **DATA SHEETS– A & B FOR ACCESSORIES**
  - **DATA SHEETS – C**
    - **QUALITY PLAN**
  - **BOQ-MAIN SUPPLY**
    - **BOQ- SPARES**

	<p align="center"><b>Sagardighi Thermal Power Project</b> 1 x 660 MW Unit No. 5, Phase-III</p> <p align="center">Technical specification for <b>Control Valve with Accessories - Feed Control Valve</b> (Pneumatically Operated)</p>	SPEC NO.: <b>PE-TS-445-145-I801A</b>	
		DOCUMENT NO.	
		VOLUME	II B
		SECTION	C
		ISSUE NO.	
		REV. NO. 00	DATE: 23.01.2023

### SPECIFIC TECHNICAL REQUIREMENTS

The requirements in this section are specific for this project and shall over-ride the specification under Section-D in case of any contradiction. However, in case of any contradiction between this SPECIFIC TECHNICAL REQUIREMENTS and customer SPECIFICATION attached further, the customer SPECIFICATION shall prevail and BHEL's decision shall be final. BIDDER to comply the stringent requirement as per BHEL decision without any commercial implication.

1. **All the formats in QUALITY PLAN (BHEL Format) should filled-up and furnished with the bid, complete in all respect. In the absence of those, the bid would be considered incomplete and liable for rejection.** Catalogue, Leaflets related with the models of Control Valves as well as each Accessory must be furnished with the offer.
2. The Hook-up diagram for Control valve, attached in Section-D. The scope demarcation as indicated should be adhered. The connection details at Instrument Air valve shall be furnished to successful bidder after the award of contract.
3. Valve Body Sizes shall be quoted to take care of the specification requirements like parameters, and limitations of Fluid outlet velocities, Noise Level etc. **However, Port (Trim) Sizes shall be selected to suit CV requirement for achieving percentage valve lift as per Technical Specification.**
4. Bidder to note that, **wherever downstream side of the valve is subjected to the Vacuum service, bidder to offer double Gland packing, and in that case, flow direction of working fluid shall be to close the valve.** Separate indication for the same has not been made in the data Sheets-A.
5. For valves subjected to cavitation service, anti-cavitation trim shall be provided.
6. In case during erection/commissioning of the control valve, any spares are required which have not been specified in the Start-up/commissioning spares list, the same will have to be supplied by the bidder free of cost.
7. Facility to adjust the maximum travel of the stem & starting point of travel shall be incorporated.
8. SS name plate for control valve shall include Tag no./ KKS no./ SI. No./ Body material/ size/ Press Rating/ Trim material/ Trim type/ action on air failure/ diaphragm air press at full open and close condition
9. Hand wheel shall have open/ close direction.
10. Limit switch shall be designed for 1,00,000 operations.

	<b>Sagardighi Thermal Power Project</b> 1 x 660 MW Unit No. 5, Phase-III  Technical specification for <b>Control Valve with Accessories - Feed Control Valve</b> (Pneumatically Operated)	SPEC NO.: <b>PE-TS-445-145-I801A</b>	
		DOCUMENT NO.	
		VOLUME	II B
		SECTION	C
		ISSUE NO.	
		REV. NO. 00	DATE: 23.01.2023

11. JB shall be 36 ways as per enclosed hook-up diagram.
12. The material of filter for Air Filter Regulator shall be sintered bronze.
13. Bidder to indicate pick-up & drop out voltage for all solenoid valves.
14. Protection class for Limit switches, Smart Positioner shall be IP-65 only.
15. All JBs and valves shall be with double compression type Ni plated brass cable glands.
16. Solenoid valve class of protection shall be IP-65, shall be of Plug and socket electrical connection.
17. All local cabling up to JBs shall be in Conduit (Flexible/Rigid).
18. Control valve accessories shall be fitted on the valve body. Junction box shall be mounted on the valve body.
19. The smart positioner provided with Control Valves shall be compatible with Universal Hart Calibrator.  
In order to interface with METSO system, the smart positioner of Control Valves has to be HART Compatible. Bidder to provide diagnostic software (for all tags) to be installed on HMS PC for communicating with the smart positioner and accessing the diagnostic features of the smart positioner. Bidder to offer latest version of calibration and diagnostic software which should be compatible with latest operating system at the time of commissioning of valve/ positioner without any additional cost to BHEL. The offered software shall be compatible with the HART MANAGEMENT SYSTEM hardware of reputed makes like MTL, P&F etc. Additionally, Vendor to provide DTM (device type manager) / DTD (device type description) files for engineering.
20. Positioner shall have both fail freeze and fail safe feature.
21. Tolerances on end to end, centre to centre, centre to face shall be in accordance with ASME B16.10.
22. The final documentation including operating manuals, maintenance and service manuals, component documentation, assembly documentation, drawings and listing, etc. shall be submitted in English language.
23. Multi-stage multi path valves shall be used for high DP valve i.e. Feed Control Valve – FDV 14.
24. Valve and actuator shall be designed for full differential pressure (Max. shut-off pressure).

	<b>Sagardighi Thermal Power Project</b> 1 x 660 MW Unit No. 5, Phase-III  Technical specification for <b>Control Valve with Accessories - Feed Control Valve</b> (Pneumatically Operated)	SPEC NO.: <b>PE-TS-445-145-I801A</b>	
		DOCUMENT NO.	
		VOLUME	II B
		SECTION	C
		ISSUE NO.	
		REV. NO. 00	DATE: 23.01.2023

25. In order to prevent the risk of fire or explosion pneumatic actuators shall be used in hazardous areas and associated equipment (e.g. positioners) must be intrinsically safe in accordance with IEC 60079-11.

26. Bidder to furnish **compliance certificate** duly signed and stamped by bidder attached further.

27. SPARES: The following spares are required to be offered

**(A) Recommended Spares:**

The bidder shall furnish a List of Recommended spares for 3 years of normal operation of the Control valves / Accessories. The BHEL/Customer reserves the right to buy any or all of the recommended spares.

The prices of these spares will remain valid for a period of minimum 6 months after the placement of order.

**(B) Start-up & Commissioning Spares:**

Start-up and Commissioning spares are those spares, which may be required during the start-up and commissioning of the Control Valves. All start-up spares, which are supplied under this contract, shall be strictly interchangeable with the parts for which they are intended for replacements.

The Start-up and commissioning spares indicated by the bidder shall be a part of the main Control valves supply. However, bidder to indicate prices separately. The list of these spares required is enclosed in the Section-C of this specification.

Bidder to indicate the service life expectancy period for the spare parts under normal working conditions. The spares shall be treated and packed for long storage, under climatic conditions prevailing at site. Small items shall be packed in sealed transparent plastic bags with desiccator's packs as necessary.

**(C) Mandatory spares:**

Bidder to supply mandatory spares as attached in specification.

	<b>Sagardighi Thermal Power Project</b> 1 x 660 MW Unit No. 5, Phase-III  Technical specification for <b>Control Valve with Accessories - Feed Control Valve</b> (Pneumatically Operated)	SPEC NO.: <b>PE-TS-445-145-I801A</b>	
		DOCUMENT NO.	
		VOLUME	II B
		SECTION	C
		ISSUE NO.	
		REV. NO. 00	DATE: 23.01.2023

## 28. Documentation:

### (A) After the award of contract:

The documentation as listed below for the project  
6 sets of the following documents + 3 sets of CDs to be enclosed with the bids for  
Approval:

- a. Assembly (dimensional) drawings.
- b. Valve Edge preparation details.
- c. Data sheet-C completely filled-up.
- d. Hook-up diagram of Control Valve with Actuator & Accessories.
- e. Valve & Actuator assembly dimensional drawings with weights.
- f. Quality Plan duly signed and stamped.
- g. All calculations like CV, Noise Level, Valve Outlet Velocity, Actuator sizing etc.
- h. All relevant catalogues for the models of the valves as well as accessories finalized.
- i. Bar chart to indicate the time schedule for procurement, manufacture, testing and dispatch.

### (B) Final documentation:

The documentation as listed below will separate for respective projects

1. Category –I & IV Approved final drawings/data sheets, – 20 sets with 4 CD-ROMS  
Valve sizing calculations, Noise level calculations and  
Valve Outlet Velocity calculations.
2. Test certificates – 20 sets.
3. Operation & Maintenance Manuals – 20 sets with 4 CD-ROMS  
for Control Valve, Actuator and all the  
Accessories.

	<b>Sagardighi Thermal Power Project</b> 1 x 660 MW Unit No. 5, Phase-III  Technical specification for <b>Control Valve with Accessories - Feed Control Valve</b> (Pneumatically Operated)	SPEC NO.: <b>PE-TS-445-145-I801A</b>	
		DOCUMENT NO.	
		VOLUME	II B
		SECTION	C
		ISSUE NO.	
		REV. NO. 00	DATE: 23.01.2023

## COMPLIANCE CERTIFICATE

**We shall comply with the following: -**

1. All the requirements as stated in Technical Specification / Specific Technical requirement / Data sheets / Drawings, BHEL quality plan etc. as enclosed in the tender, shall be fully complied **without any deviation**.
2. BHEL Quality Plan (enclosed with the specification) duly signed and stamped is submitted herewith **without any deviation**.
3. Calculation of CV, Noise level, Valve outlet velocity, Trim exit velocity, Actuator sizing, Data Sheet-C in line with Data sheet-A of specification, dimensional drawings / edge preparation details, etc shall be submitted for BHEL/Customer review and approval, to reach BHEL within 15 days after receipt of LOI.
4. Selection of valves and Actuators are our (bidder's) responsibility. Any change in selection of type of valve and Actuators / Sizing / percentage opening, calculations, QP, etc., if desired by BHEL / Customer during approval of the documents after award of contract, without major changes in process parameters as per tender Specification, shall be carried out without any commercial implication and time delay.
5. Body material and Trim material combinations offered will be equivalent or better than the material specified in data Sheet-A. Wherever Trim material combinations offered differ from the specification, its superiority shall be authenticated with documentary evidence and justification produced for BHEL / Customer's concurrence. BHEL / Customer reserves the right to accept/rejects any variation to the specification.

**(To be Signed & Stamped by the Bidder)**

Signature with date	
Name	
Company seal	

	<b>Sagardighi Thermal Power Project</b> 1 x 660 MW Unit No. 5, Phase-III  Technical specification for <b>Control Valve with Accessories - Feed Control Valve</b> (Pneumatically Operated)	SPEC NO.: <b>PE-TS-445-145-I801A</b>	
		DOCUMENT NO.	
		VOLUME	II B
		SECTION	C
		ISSUE NO.	
		REV. NO. 00	DATE: 23.01.2023

# CUSTOMER SPECIFICATION



4.00.00 **CONTROL VALVES, ACTUATORS & ACCESSORIES**

4.01.00 GENERAL REQUIREMENTS

4.01.01 Bidder shall exercise extreme caution in selecting severe service control valves like BFP recirculation valves, HP & LP bypass valves, superheater & reheater attemperator valves, PRDS valves for Boiler & Turbine, Soot blower steam pressure control valve, control valves whose down stream are connected to condenser and in vacuum such as HP/LP heater emergency level control, condenser make up water control valve and CEP minimum flow control valve etc. For such critical applications, Bidder shall offer valves which are proven for similar application for not less than 2 years of continuous service in power plant environment. All the above valves shall have leakage class equal or better than class-V or as specified hereunder with metal-to-metal seating. For Severe Service Control Valves viz. BFP Recirculation Valves, PRDS Valves, Feed Control Valve, SH/RH Attemperation valve, Soot blower steam pressure control valve etc. multistage-multipath discrete pressure drop stage design shall be provided. HP and LP Bypass valves shall be designed for 60% bypass capacity with twin valves. Typical Requirements for these Control Valves shall be as follows:

Service	:	BFP Recirculation Valve/RH-SH Attemperator Valves
Type	:	Multi Stage, Multi Path stack Plate radial Flow design
Trim	:	Angle Design (side inlet and bottom outlet, over the plug flow) or Globe design (for straight pipe)
Trim exit <i>velocity</i>	:	Not exceeding 23m/sec
Pressure reducing /drop	:	Achieved in multi stage orificed, drilled hole or axial flow cage design
Seat Leakage	:	In accordance with MSS-SP-61
Actuator type	:	Pneumatic Piston type ensuring MSS-SP-61 seat leakage

4.01.02 Control valves for regulating service shall normally be globe body, cage guided, metal-to-metal seated, pneumatically operated and shall be provided with characterized plugs having ANSI leakage class-IV as minimum. All steam temperature conditioning control valves shall be ANSI leakage class-V.





- 4.02.00 VALVE CONSTRUCTION
- 4.02.01 All valves shall generally be of globe body design and straight through pattern with single seat unless otherwise is specified or recommended by the manufacturer for particular application. However, Bidder may offer angle body valve for high pressure drop applications. For high pressure drop applications, construction of the valve shall be such that the gland is not exposed to full line pressure.
- 4.02.02 Valves with high lift cage guided plugs and quick replacement trims shall be provided for easy maintenance.
- 4.02.03 Plug shall be one piece construction either cast, forged or machined from solid stock. Plug shall be screwed and pinned to valve stem or shall be integral with valve stem.
- 4.02.04 Bonnet joint shall be of flanged and bolted type or manufacturer standard acceptable to Owner. Bonnet joints of internal threaded or union type is not acceptable.
- 4.02.05 Extension Bonnet shall be provided for fluid temperature above 280 deg C.
- 4.02.06 Valve characteristics shall match with the process characteristics.
- 4.02.07 All valves connected to vacuum on down stream side shall be provided with packing suitable for vacuum application (i.e. double vee type chevron packing).
- 4.02.08 Flanged valves shall have minimum body rating ANSI 300 lbs.
- 4.02.09 The direction of flow shall be clearly marked/engraved on the body.





4.02.10 Valve body rating shall meet the process pressure and temperature requirement as per ANSI B 16.34.

4.03.00 VALVE BODY

Valve body material shall generally be guided as per the Table below:

<u>SR. NO.</u>	<u>SERVICE</u>	<u>BODY MATERIAL</u>
1.	Non corrosive, non-flashing and non cavitating service for fluid temperature upto 275°C (like Aux steam flow to Deaerator, condensate flow to Deaerator, CRH flow to Deaerator)	Compatible with piping material but not inferior to Cast carbon steel ASTM A216 Gr. WCB
2.	Severe flashing / cavitating services (like HP & LP heaters emergency drain, Deaerator overflow drain to hotwell etc.)	Alloy steel as per ASTM A217 Gr. WC9
3.	Low flashing / cavitating services (like HP & LP heaters normal drain level control, GSC minimum flow, gland seal steam pressure control etc.)	Alloy steel as per ASTM A217 Gr. WC6
4.	DM water application (like condenser hotwell normal and emergency make up, ECW DP control etc.)	316 stainless steel ASTM A351 Gr. CF8M

4.04.00 VALVE TRIM

4.04.01 Valve trim for most applications up to leakage class-V shall be stainless steel 316 SS for pressure drop up to 7 Kg/ Sq. cm.. For pressure drops above 7 Kg/Sq. cm hard trim (stellite or equivalent) shall be used. Other alloys shall be substituted if required for corrosion and other fluid conditions.

4.04.02 Balanced trim valves shall be offered for high shut-off pressure or high pressure drop condition to reduce the size of the actuators. For flashing services and two stage mixtures, the trim material shall be 17-4 PH or equivalent. If cavitating condition is foreseen, Bidder shall offer multistage or labyrinth trim valves. Trim of severe service valves as indicated in Cl. 4.01.01 shall be of multistage and multipath design with sufficient no. of discrete





pressure drop stages to eliminate the chances of erosion, cavitation, noise and vibration throughout the control range of the valve.

4.04.03 Quick replacement type trim shall be considered for easy maintenance.

4.04.04 Trim Material

Valve trim material shall generally be guided as per the Table below :

<b><u>SR. No.</u></b>	<b><u>SERVICE</u></b>	<b><u>MATERIAL</u></b>
1.	Non corrosive, non-flashing and non cavitating service for fluid temperature upto 275°C.	316 SS with satellite faced guide posts and bushings
2.	Severe flashing / cavitating services	400 series SS or equivalent to suit the specific requirement
3.	Low flashing / cavitating services	400 series SS or equivalent to suit the specific requirement
4.	DM water application (condenser hotwell normal, emergency make up etc.)	316 SS

cavitation resistance, corrosion resistance, temperature resistance, erosion resistance, hardness etc. of the offered material vis-à-vis the specified material for Bidder may offer valves with body and trim material better than the specified material and in such cases Bidder shall furnish the comparison of properties including Owner’s approval.

4.05.00 VALVE END PREPARATION

Valve body ends shall be either butt welded/socket welded, or flanged (Rubber lined for condensate service). Control valves of size 65 mm and above shall have butt welded ends as per ANSI B 16.25. For valve size 50 mm and below welded ends shall be socket welded as per ANSI B 16.11. Flanged ends shall be of ANSI pressure-temperature class equal to or greater than that of control valve body.

4.06.00 VALVE SIZE

The control valve sizing (Cv / Kv) shall be based on following guidelines :

- a) The valves shall pass normal rate of flow (MCR condition) with 65 to 75 percent opening for linear characterised valves and 75 to 85 percent opening for equal percentage characterised valves.
- b) The valves shall have adequate rangeability to pass the minimum and maximum rated flows at 10% and 80% of the valve opening





respectively. Valve stem travel range from minimum to maximum flow condition shall not be less than 50% of the total valve stem travel.

- c) Valve Cv shall be selected in such a way that the valve shall be capable of handling at least 120% of required rated flow.
- d) The valve selection shall be based on the highest size dictated by the above considerations unless noise, flashing or other factors dictate the final selection.
- e) The sizing procedure followed shall be as per latest edition of ANSI/ISA or equivalent standard.
- f) While deciding the valve size, Bidder shall ensure that valves port outlet velocity does not exceed 8 m/sec for liquid services, 150 m/sec for steam services and 50% of sonic velocity for flashing services.
- g) Control valve induced noise shall not greater than 85 dBA at 1 meter from the valve surface under actual operating conditions. The noise abatement shall be achieved by valve body and trim design and not by use of silencers.
- h) Bidder shall submit the sizing calculation clearly indicating the valve outlet velocity, noise calculation during detail engineering stage for Owner's approval.

4.07.00 VALVE TOPWORK

4.07.01 Topwork shall be sized so that the valve shall operate properly when upstream pressure is 10 percent above maximum inlet pressure and downstream pressure is atmospheric.

4.07.02 Bonnet material shall be same as that of valve body or equivalent forged material.

4.07.03 Extended bonnet/Finned bonnet and high temperature packing shall be used for high temperature application. Extension bonnet shall be used when the fluid temperature is high and may damage valve stem packing.

4.07.04 The gland material shall be chosen to suit the operating temperature. PTFE may be chosen for low temperature application and for high temperature application graphited asbestos glands are to be provided. For vacuum services, the glands shall be dry seal type.

4.08.00 NOISE LEVEL

The equivalent sound level measured at 1.5 M above nearest floor level in elevation and 1 M horizontally from the control valve expressed in decibels to a reference of 0.0002 microbar shall not exceed 85 dBA. If the calculated noise is more than the above limit, even with low noise trim design, diffusers shall be included. Diffusers shall be made of stainless steel and shall be integrally connected to the control valve with necessary spool piece. The spool piece shall be in conformity with the main line piping specification.





- 4.09.00 VALVE ACTUATORS
- 4.09.01 Spring-diaphragm type valve actuators shall be used in general applications. However piston type actuators shall be offered in case of high shut-off pressure & quick response requirement. Bidder shall provide piston type actuators for regulating services for the following services as a minimum requirement. Piston actuator shall be of double acting type for the regulating duty valves with long stem travel for better regulation and quick response.
- a) Auxiliary Pressure reducing & De-super heating stations.
  - b) Superheat and Reheat Spray Control Valves.
  - c) Condensate extraction pump minimum recirculation valve.
  - d) Feed control valves
- 4.09.02 The actuator shall be designed for 150% thrust required for the valve (at shut-off pressure) at an air line supply pressure of 5.5 Kg/Sq. cm.
- 4.09.03 All the actuators shall be supplied mounted on the valve with all the accessories integrally mounted. The diaphragms shall be designed for 200% maximum operating pressure.
- 4.09.04 Nylon reinforced neoprene shall be used as diaphragm material.
- 4.09.05 Valve actuators shall be capable of operating at 60 deg C ambient, continuously.
- 4.09.06 Entire actuator assembly shall be painted with corrosion inhibiting paint.
- 4.09.07 Air connection size shall be 1/4" NPT (F) unless otherwise dictated by process response time. Integral tubing shall be of stainless steel construction.
- 4.09.08 Bidder shall indicate the stroking time of the valve assemblies with positioner, which shall not exceed 10 sec unless otherwise stated.
- 4.09.09 All actuators shall be of fail safe design signifying that the spring direction will tend to move the valve (open or close) in a direction safe for the process. "Failure to Open" or "Failure to Close" shall be marked on the actuator.
- 4.09.10 HP and LP bypass and spray valves, turbine inlet stop & control valves shall be electro-hydraulic actuators and all other control valves shall have pneumatic actuators.
- 4.10.00 VALVE POSITIONERS
- 4.10.01 All regulating service valves shall be offered with HART protocol based Smart Electro Pneumatic Positioners to ensure accuracy and repeatability of response.
- 4.10.02 Positioners shall have integral I-P converter, Position feedback transmitter, input and output gauges, local keypad & display .





4.10.03 Positioners shall be capable of functioning under hot, humid and vibrating conditions.

4.10.04 Positioner casings shall be dust tight, corrosion resistant and weatherproof (IP-55).

4.10.05 In general, positioner shall operate at signal range 4 – 20 mA DC for the full travel of the valve. Split range operation in few cases may be required. Remote calibration from control room shall be possible through HART management station.

4.11.00 VALVE ACCESSORIES

The accessories of the valves shall include side mounted hand wheels, smart positioner, limit switches, tubing and air set, junction boxes, airlock relays, volume booster, solenoid valves, and any other devices as required.

4.12.00 TESTS

All valves shall be tested in accordance with the Quality Assurance Programme (QAP). Bidder shall submit QAP for Owner's approval. The tests shall include but not be limited to the following :

01. Non destructive test as per ANSI B 16.34.
02. Hydrostatic shell test as per ANSI B 16.34 prior to seat leakage test.
03. Valve closure test and seat leakage test as per ANSI B 16.34 and as per the leakage class
04. Functional test : The fully assembled valves with actuator and all accessories shall be functionally tested to demonstrate from open to close position and vice versa. Valve lift shall be checked at 5 points at 0, 25, 50, 75 and 100% in both the directions with increasing and decreasing inputs. Performance of the valve with Positioner shall be as follows :
  - a. Linearity : +/- 1%
  - b. Hysteresis : +/- 1%
  - c. Sensitivity : +/- 0.5%
  - d. Deadband : +/- 1%
  - e. Reproducibility : 0.3% of total stroke
  - f. Overall accuracy : +/- 1%
05. CV test : Cv test shall be carried out as type test on each size, type and design of the valves as per ISA 75.02 standard and test report shall be submitted for Owner's approval.





**4.00.00**

**GENERAL TECHNICAL REQUIREMENTS**

**4.07.00**

Final control device for regulating control shall have pneumatic actuator. Actuators for isolating and inching duty dampers and valves shall be, in general, electrical motor operated. Generally pneumatic actuators for ON-OFF services shall not be considered unless process requirement demand to use same. Actuators for isolating and inching duty type dampers/valves shall have limit switch. SMART positioner along with position transmitter (4 - 20 mA output) and limit switches shall be provided for all types of control valves. SMART positioners shall be HART compatible. Hydraulic operated control valves shall also be operated from DCS in addition to the local control. All control valves shall have motorised isolation valve in the upstream and downstream line. Moreover the bypass line shall be provided.





- 1.22.00 Air Filter Regulator
- 01. Filter Element : Sintered Bronze
  - 02. Filter Size : 5 microns
  - 03. Input Air : 10.0 Kg/Sq. cm (maximum)
  - 04. Output : Adjustable from 0-2.0 Kg / Sq. cm or 0-7.0 Kg / Sq. cm (continuous) as applicable.
  - 05. Effect of Supply : Maximum 0.02 Kg/Sq. cm for a change pressure variation in supply pressure of 4 Kg/Sq. cm
  - 06. Bowl Material : Metallic.
  - 07. Accessories : 2" dial size output pressure gauge
  - 08. Feature : No perceptible drop of pressure on opening the drain port.
- 1.23.00 SOLENOID VALVE
- 01. Operating Principle : Electromagnetic (noiseless)
  - 02. Coil voltage rating : 24V DC (in general) other 220V DC /240V AC /110V AC as required





- 03. Ways : 3 ways in general other depending on requirement
- 04. Port size : 1/4" NPT all ports
- 05. Body : SS Bar Stock
- 06. Trim : AISI SS-316
- 07. Manual Operator : In built
- 08. Duty : Suitable for continuous energization
- 09. Sealing : Airtight and leak proofing with nitrile (NBR) and polyurethane (PUR) material
- 10. Ambient Temperature : 0 - 50° C
- 11. Fluid Temperature : 0-150° C (approx.)
- 12. Coil Enclosure : Stainless Steel
- 13. Insulation : Class-H
- 14. Coil Casing : IP-65 (Explosion proof for NEC Class-1, Division-1 area)
- 15. Response time : 4-7msec
- 16. Mounting : On pipe or on panel
- 17. Cable Connection : 1/2" NPT cable gland
- 18. Accessories : Mounting brackets, nuts and bolts
- 19. Special feature : (i) LED indication for power  
(ii) Double coil type for open & close operation of valve / damper.  
(iii) Solenoid valve directly integral to actuator body shall have NAMOOR interface for uniformity





- 1.42.00 SMART POSITIONER
- 01. Type : Universal design (linear or rotary application)
  - 02. Input Signal : 4-20mA DC , 2 wire loop with 24V DC.
  - 03. Output Signal (position F/B) :
    - i) 4-20mA
    - ii) Configurable end position switch
  - 04. Supply Pressure :
    - Single acting 1.2 to 7.0 bar
    - Double acting 1.2 to 10.5 bar
  - 05. Air Delivery :
    - Single acting 10.0 SCFM at 2.1 bar supply
    - Double acting 7.2 SCFM at 2.1 bar supply
  - 06. Housing : IP 65
  - 07. Repeatability : +/- 0.3% of span or better
  - 08. Accuracy : +/- 0.1% of span or better
  - 09. Communication : Hart protocol
  - 10. Power-up with position : < 150 ms or better control
  - 11. Power interruption without reset : <100ms or better
  - 12. Body Material : Aluminium
  - 13. Response Time : Less than 10 sec





**5.04.04 Junction Box**

Junction boxes shall be of metallic construction.

- a) Junction box shall be provided with front opening type cover. Junction box shall be of sheet steel construction with thickness not less than 2 mm. Junction box shall be complete with DIN rail mounted terminals, MCB, receptacles and earth bar. Earth bar shall be made of tinned copper of 25 X 6 MM size. Earth stud shall be furnished for safety grounding.
- b) Terminals shall be screwless cage-clamp type and 20% spare terminals shall be furnished. Power terminals shall be screw type.





## Sagardighi Thermal Power Project

1 x 660 MW Unit No. 5, Phase-III

Technical specification for  
**Control Valve with Accessories - Feed Control Valve**  
 (Pneumatically Operated)

SPEC NO.: PE-TS-445-145-I801A

DOCUMENT NO.

VOLUME II B

SECTION C

ISSUE NO.

REV. NO. 00

DATE: 23.01.2023

## SECTION-C

## DATASHEET A&B





<b>BHEL PEM</b>	<b>DATA SHEET FOR CONTROL VALVES (WITH PNEUMATIC ACTUATOR)</b>		SPECIFICATION NO.: <b>PE-TS-445-145-I104</b>	
			VOLUME	
			SECTION	
			REV. NO. 03	DATE: 17.05.2022
			SHEET 56	OF 62

Tag No. : Applicable for all tag nos.      Quantity: As required

Data Sheet No. PES-145-06-  
DS1-1

APPLICABLE FOR TAG NOS.WHEREVER STATEMENT “**REQUIRED**” INDICATED IN THE INDIVIDUAL CV DATA SHEETS

**DATA SHEET – A & B for ACCESSORIES**

DATA SHEET – A FOR CONTROL VALVE (WITH PNEUMATIC ACTUATOR) (TO BE FILLED BY PURCHASER)				DATA SHEET – B (TO BE FILLED-UP BY BIDDER)		
<b>POSITIONER</b>	MFR. & MODEL NUMBER			BIDDER TO SPECIFY		
	BYPASS	GAUGES	ENCL. CLASS	<input type="checkbox"/> YES <input checked="" type="checkbox"/> NO	<input type="checkbox"/> THREE <input checked="" type="checkbox"/> TWO	<input checked="" type="checkbox"/> IP-65
	INPUT SIGNAL			4-20 mA DC		
	OUTPUT SIGNAL (Kg / Cm <sup>2</sup> )			TO SUIT ACTUATOR		
	MFR. & MODEL NUMBER			BIDDER TO SPECIFY		
<b>AIR FILTER REGULATOR</b>	AIR SUPPLY PRESS (Kg / Cm <sup>2</sup> g)			<input checked="" type="checkbox"/> 5.0 – 7.0 <input type="checkbox"/>		
	OUTPUT PRESS (Kg / Cm <sup>2</sup> g)			TO SUIT ACTUATOR		
	FILTER SIZE			5 MICRON		
	OUTPUT GAUGE			<input checked="" type="checkbox"/> REQUIRED <input type="checkbox"/> NOT REQUIRED		
	AUTO DRAIN FEATURE			<input checked="" type="checkbox"/> REQUIRED <input type="checkbox"/> NOT REQUIRED		
<b>AIR LOCK</b>	MFR. & MODEL NUMBER			BIDDER TO SPECIFY		
	SET PRESS (Kg / Cm <sup>2</sup> )					
	SUPPLY PRESS (Kg / Cm <sup>2</sup> )			<input checked="" type="checkbox"/> 5.0 – 7.0 <input type="checkbox"/>		
	RESET TYPE			AUTO		
	VENT PLUG			REQUIRED		
<b>LIMIT SWITCH</b>	MFR. & MODEL NUMBER			BIDDER TO SPECIFY		
	OPEN posn	INT posn	CLOSE posn	<b>1 NO.</b>	---	<b>1 NO.</b>
	CONTACT TYPE			SPDT		
	RATING (AC / DC)			5A 240V AC AND 0.5A 220V DC		
	ENCLOSURE CLASS			<input checked="" type="checkbox"/> IP 65 <input type="checkbox"/> NEMA-4		
<b>POSITION TRANSMITTER</b>	MFR. & MODEL NUMBER			BIDDER TO SPECIFY (Part of SMART Positioner)		
	TYPE			<input checked="" type="checkbox"/> Electronic (2-Wire) Contactless <input type="checkbox"/> OTHER		
	SUPPLY			<input checked="" type="checkbox"/> 24V DC <input type="checkbox"/> 220V DC <input type="checkbox"/> 110V AC <input type="checkbox"/> 240V AC		
	OUTPUT RATING			<input checked="" type="checkbox"/> 4-20mA <input type="checkbox"/> 0-100 ohms		
	ACCURACY			± 1% FS		
	ENCLOSURE CLASS			<input checked="" type="checkbox"/> IP 65 <input type="checkbox"/> NEMA-4		
<b>SOLENOID VALVE</b>	MFR. & MODEL NUMBER			BIDDER TO SPECIFY		
	RATING			<input checked="" type="checkbox"/> 24V DC <input type="checkbox"/> 220V DC <input type="checkbox"/> 240V AC <input type="checkbox"/>		
	TYPE			3-WAY (UNIVERSAL OPERATION TYPE)		
	OPERATION	QUANTITY		<input type="checkbox"/> Stayput <input checked="" type="checkbox"/> Interlock <input checked="" type="checkbox"/> 1 <input type="checkbox"/> 2		
	COIL INSULATION CLASS			CLASS - H		
	ENCLOSURE CLASS			<input checked="" type="checkbox"/> IP 65 <input type="checkbox"/> NEMA 4 <input type="checkbox"/>		
<b>HANDWHEEL</b>	ORIENTATION			<input type="checkbox"/> TOP MOUNTED <input checked="" type="checkbox"/> SIDE MOUNTED		
<b>JUNCTION BOX</b>	NO. OF WAYS			<input type="checkbox"/> 24-WAYS <input type="checkbox"/> AS REQUIRED <input checked="" type="checkbox"/> 36-Ways		
	SIZE			AS REQUIRED		
	CABLE GLANDS (Size / Quantity)			AS REQUIRED (Double Compression Type).		
	ENCLOSURE CLASS			<input checked="" type="checkbox"/> IP 65 <input type="checkbox"/> NEMA-4		
	BODY MATERIAL			<input type="checkbox"/> FRP <input type="checkbox"/> SS <input checked="" type="checkbox"/> METAL SHEET		
<b>I/P CONVERTER (Part of SMART Positioner)</b>	INPUT SIGNAL	POWER SUPPLY		4-20mA DC    24V DC		
	SPLIT RANGE			<input type="checkbox"/> YES <input type="checkbox"/> NO		
	ENCLOSURE CLASS			<input checked="" type="checkbox"/> IP 65 <input type="checkbox"/> NEMA-4		
<b>VOLUME BOOSTER</b>	MAKE. & MODEL NUMBER			BIDDER TO SPECIFY		
<b>SS Tubing &amp; Fittings / per CV</b>	This is in addition to SS Tubing and fittings which are integral part of CV as per ASTM B68 to B75 (USA)			25 Meters of ¼" SS Tubing, with 1 set of Fittings for each CV for connection to IA Header on one end and accessories on another end of CV.		
<b>PAINTING</b>	COLOUR/SHADE			<input checked="" type="checkbox"/> RED <input type="checkbox"/> GREEN <input type="checkbox"/>		
	THICKNESS (DFT) – in microns			80-100		
	TYPE			<input checked="" type="checkbox"/> EPOXY <input type="checkbox"/> ENAMEL <input type="checkbox"/>		

	<p align="center"><b>Sagardighi Thermal Power Project</b> 1 x 660 MW Unit No. 5, Phase-III</p> <p align="center">Technical specification for <b>Control Valve with Accessories - Feed Control Valve</b> (Pneumatically Operated)</p>	SPEC NO.: <b>PE-TS-445-145-I801A</b>	
		DOCUMENT NO.	
		VOLUME	II B
		SECTION	C
		ISSUE NO.	
REV. NO. 00	DATE: 23.01.2023		

**SECTION-C**

**DATASHEET C**



**Sagardighi Thermal Power Project**  
1 x 660 MW Unit No. 5, Phase-III

Technical specification for  
**Control Valve with Accessories - Feed Control Valve**  
(Pneumatically Operated)

SPEC NO.: PE-TS-445-145-I801A	
DOCUMENT NO.	
VOLUME	II B
SECTION	C
ISSUE NO.	
REV. NO. 00	DATE: 23.01.2023

Data Sheet No. PES-145-06-DS2-1

Tag No..... Quantity.....

DATA SHEET C

DATA SHEET – C FOR CONTROL VALVE (WITH PNEUMATIC ACTUATOR)  
(TO BE FILLED BY THE BIDDER AFTER THE AWARD OF CONTRACT)

<b>GENERAL*</b>	PROJECT	
	SERVICE	
	LOCATION	
	DUTY	
	PIPE SIZE (inlet / outlet)	
	PIPE MATERIAL (inlet / outlet)	
<b>BODY</b>	MODEL NUMBER	
	TYPE OF BODY : GUIDING : NO. OF PORTS	
	BODY SIZE : PORT SIZE : DESIGN CV	
	END CONNECTION & RATING (ANSI)	
	BODY MATERIAL	
	PACKING MATERIAL SINGLE / DOUBLE	
	BONNET TYPE	
	TRIM FORM	
	TRIM MATERIAL : SEAT   PLUG	
	TRIM MATERIAL : CAGE   GUIDE	
	FLOW	
	OUTLET VELOCITY	
	REQUIRED LEAKAGE CLASS	
	NOISE LEVEL (dBA)	
VACUUM SERVICE		
ANTI CAVITATION TRIM		
<b>PNEUMATIC ACTUATOR</b>	MODEL NO. & SIZE	
	CLOSE AT : OPEN AT (Kg / Cm <sup>2</sup> g)	
	*TRAVEL TIME FOR OPEN TO CLOSE, CLOSE TO OPEN	
	*VALVE POSN. ON SIGNAL AIR FAILURE	
	*VALVE POSN. ON SUPPLY AIR FAILURE	
<b>ACCESSORIES</b>	POSITIONER(SMART)	
	AIR FILTER REGULATOR	
	AIR LOCK RELAY	
	POSITION LIMIT SWITCH	
	POSITION TRANSMITTER	
	SOLENOID VALVE	
	E / P CONVERTER	
	JUNCTION BOX	
	HAND WHEEL (SIDE MOUNTED)	
	LOCAL POSITION INDICATOR	



**Sagardighi Thermal Power Project**  
1 x 660 MW Unit No. 5, Phase-III

Technical specification for  
**Control Valve with Accessories - Feed Control Valve**  
(Pneumatically Operated)

SPEC NO.: <b>PE-TS-445-145-I801A</b>	
DOCUMENT NO.	
VOLUME	II B
SECTION	C
ISSUE NO.	
REV. NO. 00	DATE: 23.01.2023

Tag No.....		Quantity.....		Data Sheet No. PES-145-06-DS2-1					
<b>DATA SHEET C</b>									
<b>DATA SHEET – C FOR CONTROL VALVE (WITH PNEUMATIC ACTUATOR)</b> (TO BE FILLED BY THE BIDDER AFTER THE AWARD OF CONTRACT)									
<b>PERFORMANCE OF VALVE</b>	HYSTERSIS								
	LINEARITY								
	SENSITIVITY								
	ACCURACY (Overall)								
<b>SERVICE CONDITION*</b>	<b>SL.+ NO.</b>	<b>LOAD</b>	<b>FLOW (T/HR)</b>	<b>INLET PR. (KG/CM<sup>2</sup> (A))</b>	<b>OUTLET PR. (KG/CM<sup>2</sup> (A))</b>	<b>TEMP DEG. C</b>	<b>CALCULATED CV</b>	<b>% VALVE LIFT</b>	<b>VALVE O/L VELOCITY</b>
VALVE TYPE									
* MAX SHUT OFF PRESS ((KG/CM <sup>2</sup> g)									
* BODY DESIGN : PRESS ((KG/CM <sup>2</sup> g)   TEMP (DEG. C)									
* IBR FORM III-C									
TOTAL WEIGHT (VALVE + ACTUATOR + ACCESSORIES) KG.									
SEA WORTHY PACKING      APPLICABLE / NOT APPLICABLE									



# Sagardighi Thermal Power Project

1 x 660 MW Unit No. 5, Phase-III

## Technical specification for Control Valve with Accessories - Feed Control Valve (Pneumatically Operated)

SPEC NO.: PE-TS-445-145-I801A	
DOCUMENT NO.	
VOLUME	II B
SECTION	C
ISSUE NO	
REV. NO. 00	DATE: 23.01.2023

Data Sheet No. PES-145-06-DS2-1

Tag No..... Quantity.....

### DATA SHEET C FOR ACCESSORIES

#### DATA SHEET – C FOR CONTROL VALVE (WITH PNEUMATIC ACTUATOR) (TO BE FILLED BY THE BIDDER AFTER THE AWARD OF CONTRACT)

<b>POSITIONER</b>	MFR. & MODEL NUMBER		
	BYPASS	GAUGES	ENCL. CLASS
	INPUT SIGNAL (Kg / Cm <sup>2</sup> )		
	OUTPUT SIGNAL (Kg / Cm <sup>2</sup> )		
<b>AIR FILTER REGULATOR</b>	MFR. & MODEL NUMBER		
	AIR SUPPLY PRESS (Kg / Cm <sup>2</sup> g)		
	OUTPUT PRESS (Kg / Cm <sup>2</sup> g)		
	OUTPUT GAUGE		
	FILTER SIZE		
	AUTO DRAIN FEATURE		
<b>AIR LOCK</b>	MFR. & MODEL NUMBER		
	SET PRESS (Kg / Cm <sup>2</sup> )		
	SUPPLY PRESS (Kg / Cm <sup>2</sup> )		
	RESET TYPE		
	VENT PLUG		
<b>LIMIT SWITCH</b>	MFR. & MODEL NUMBER		
	OPEN posn	INT posn	CLOSE posn
	CONTACT TYPE		
	RATING (AC / DC)		
	ENCLOSURE CLASS		
<b>POSITION TRANSMITTER</b>	MFR. & MODEL NUMBER		
	TYPE		
	SUPPLY		
	OUTPUT RATING		
	ACCURACY		
<b>SOLENOID VALVE</b>	MFR. & MODEL NUMBER		
	RATING		
	OPERATION	QUANTITY	
	COIL INSULATION CLASS		
	ENCLOSURE CLASS		
<b>HANDWHEEL</b>	ORIENTATION		
<b>JUNCTION BOX</b>	NO. OF WAYS		
	SIZE		
	CABLE GLANDS (Size / Quantity)		
	ENCLOSURE CLASS		
	BODY MATERIAL		
<b>I/P CONVERTER</b>	INPUT SIGNAL	POWER SUPPLY	
	SPLIT RANGE		
	ENCLOSURE CLASS		
	LINEARITY		
	HYSTERISIS		
<b>Cu./SS Tubing &amp; Fittings / per CV</b>	15 Meters of ¼ " PVC coated SS Tubing, with 1 set of Fittings for each CV for connection to IA Header on one end and accessories on another end of CV.		
<b>PAINTING</b>	COLOUR/SHADE		
	THICKNESS (DFT)		
	TYPE		
			COMPANY SEAL
			NAME
			SIGNATURE
			DATE



# Sagardighi Thermal Power Project

1 x 660 MW Unit No. 5, Phase-III

Technical specification for  
**Control Valve with Accessories - Feed Control Valve**  
(Pneumatically Operated)

SPEC NO.: <b>PE-TS-445-145-I801A</b>	
DOCUMENT NO.	
VOLUME	II B
SECTION	C
ISSUE NO.	
REV. NO. 00	DATE: 23.01.2023

## SECTION-C

## QUALITY PLAN



PEM :: C&I

## QUALITY PLAN FOR CONTROL VALVE (PNEUMATIC)

QUALITY PLAN NO.: <b>PE-QP-445-145-I 006</b>	
VOLUME	IIB
SECTION	D
REV. NO.	03
DATE:	02.06.2022
SHEET	1 OF 7

SI. No.	Component / operation	Characteristics Checked	* Category	Type/Method of Check	Extent of Check	Reference documents	Acceptance Norms	Format of Records	Agency \$			Remarks
									P	W	V	
<b>1.0</b>	<b>MATERIAL</b>											
1.1	Body & Bonnet casting / forgings, plug, valve stem, seat ring/cage	1. Physical, Chemical properties	MA	Physical, Chemical tests	One/ Heat(HT Batch)	Approved drg. / data sheet	Approved drg./ data sheet	Test Certificate	3	---	2,1,4 	TC for body/ bonnet from foundry only
		2. Heat Treatment	MA	Review of H.T. Chart	Each H.T.	Approved drg. / data sheet	Approved drg. / data sheet	Test Certificate	3/2	2	1,4 	1.IBR Certification (if applicable) to be verified by BHEL. 2.Applicable for body/bonnet only
		3. Internal quality of castings	MA	RT for Body & UT for Bonnet	100%	ASME B 16.34	ASME B 16.34	Test Report / FILM	3/2	2	1,4 	Applicable for Body and Bonnet for rating ANSI 900 and above.
		4. Surface Quality	MA	1. Visual	100%	ANSI/ MSS-SP-55	ANSI/ MSS-SP-55	Test Certificate	3/2	---	2,4 	
				2. MT/PT	100%	ASME B 16.34	ASME B 16.34	Test Certificate	3	2	1,4 	After Machining on machined surface only
		5. Pressure test for shell	MA	Hyd. Test	100%	ISA-S-75.19/ ASME B 16.34	ISA-S-75.19/ ASME B 16.34	Test Certificate	2	2	1,4 	For Body & Bonnet after machining

LEGEND:

\* CR - Critical characteristics  
MA - Major characteristics  
MI - Minor characteristics

RT- Radiographic Test  
UT - Ultrasonic Test

PT - Dye penetrant Test  
MT- Magnetic Test

\$ P - Agency Performing the Test.  
W - Agency Witnessing the Test.  
V - Agency Verifying the Test.

1 - BHEL  
2 - Vendor  
3 - Sub-vendor

4 - WBPDCI  
/WBPDCI TPIA





**QUALITY PLAN  
FOR  
CONTROL VALVE (PNEUMATIC)**

QUALITY PLAN NO.: <b>PE-QP-445-145-I 006</b>	
VOLUME	IIB
SECTION	D
REV. NO.	03
DATE:	02.06.2022
SHEET	2 OF 7

Sl. No.	Component / operation	Characteristics Checked	* Category	Type/Method of Check	Extent of Check	Reference documents	Acceptance Norms	Format of Records	Agency \$			Remarks
									P	W	V	
1.2	Diaphragm	1. Surface Quality	MA	Visual	100%	Mfr. standard	Mfr. standard	Test Certificate	3/2	---	2,4 	
		2. Hardness	MA	Measurement	100%	Mfr. standard	Mfr. standard	Test Certificate	3/2	---	2,4 	
		3. Endurance / Life cycle	MA	Cyclic test 10,000 cycles	One / Type	10,000 cycles/ Mfr. standard.	No damage	Test Certificate	3/2	---	2,1, 4 	
1.3	Spring	1. Composition	MA	Chemical-Analysis	One sample/ Heat	Material spec. / Mfr. standard	Material spec. / Mfr. standard	Test Certificate	3	---	2,4 	
		2. Mech. Properties	MA	Mech. Test	One sample/ Heat	Material spec. / Mfr. standard	Material spec. / Mfr. standard	Test Certificate	3	---	2,4 	
		3. Performance	MA	1. Stiffness ratio	100%	Material spec. / Mfr. standard	Material spec. / Mfr. standard	Test Certificate	3	---	2,4 	
				2. Scragging	100%	Material spec. / Mfr. standard	Material spec. / Mfr. standard	Test Certificate	3	---	2,4 	
				3. Cyclic test (Endurance)	One / type	10,000 cycles	Material spec. / Mfr. standard	Test Certificate	3	---	2,1, 4 	
				4. Dimension (Measurement)	One sample/ Lot	Mfr. standard	Mfr. standard	Record	3	---	2,4 	

**LEGEND:**

\* CR - Critical characteristics  
MA - Major characteristics  
MI - Minor characteristics

RT- Radiographic Test  
UT - Ultrasonic Test

PT - Dye penetrant Test  
MT- Magnetic Test

\$ P - Agency Performing the Test.  
W - Agency Witnessing the Test.  
V - Agency Verifying the Test.

1 - BHEL  
2 - Vendor  
3 - Sub-vendor

4 - WBPDCI  
/WBPDCI TPIA





**QUALITY PLAN  
FOR  
CONTROL VALVE (PNEUMATIC)**

QUALITY PLAN NO.: **PE-QP-445-145-I 006**  
 VOLUME IIB  
 SECTION D  
 REV. NO. 03 DATE: 02.06.2022  
 SHEET 3 OF 7

Sl. No.	Component / operation	Characteristics Checked	* Category	Type/Method of Check	Extent of Check	Reference documents	Acceptance Norms	Format of Records	Agency \$			Remarks
									P	W	V	
1.4	Electrical items [Limit switches, Solenoids, Position Transmitter(if provided externally)]	1. Routine Test	MA	HV, IR, Continuity function	100%	Relevant Standards	Relevant Standards	Test Certificate 	3	---	2,4 	Certificate of Conformance (C.O.C)
		2. Degree of protection	MA	IP/NEMA Tests	One sample / type	Approved Data sheet	Approved Data sheet	Test Certificate 	3	---	2,1,4 	C.O.C
1.5	Pressure Gauges (if provided externally)	1. Performance	MA	Review of calibration certificates	100%	Mfr. Standard	Mfr. Standard	Test Certificate 	3	---	2,4 	C.O.C
		2. Marking	MA	Visual	100%	Mfr. standard	Mfr. standard	Test Certificate 	3	---	2,4 	C.O.C
<b>2.0</b>	<b>IN PROCESS INSPECTION</b>											
2.1	After machining, i. Body ii. Bonnet iii. Plug iv. Valve Stem v. seat ring/cage	1. Surface flaws	MA	Visual & MT/PT	100% (on accessible surfaces)	ASME B 16.34	ASME B 16.34	Test Records	2	---	1,4 	Butt weld ends shall be included.
		2. Dimensional checks	MA	Measurement	100%	Mfr. Standard	Mfr. Standard	Records	2	---	1,4 	
		3. Hard facing (wherever applicable)	MA	Hardness Measurement	One sample/Lot	Mfr. Standard	Mfr. Standard	Records	2	---	1,4 	
<b>3.0</b>	<b>TESTS ON COMPLETED VALVE</b>											
3.1	Actuator Chamber	Leakage & Strength	MA	Pneumatic test	100%	Mfr. Standard	No Leakage	Test Certificate	2	1,4 	1,4	Refer Note-4
3.2	Body	Leakage and Pressure test (Body Mount Leakage)	MA	Hydro test	100%	ISA - S-75.19/ASME B16.34	No Leakage	Test Certificate	2	1,4 	1,4	Refer Note-4

LEGEND: \* CR - Critical characteristics RT- Radiographic Test PT – Dye penetrant Test \$ P - Agency Performing the Test. 1 - BHEL 4 - WBPDCI  
 MA - Major characteristics UT – Ultrasonic Test MT- Magnetic Test W - Agency Witnessing the Test. 2 - Vendor /WBPDCI TPIA  
 MI - Minor characteristics V - Agency Verifying the Test. 3 - Sub-vendor



**QUALITY PLAN  
FOR  
CONTROL VALVE (PNEUMATIC)**

QUALITY PLAN NO.: <b>PE-QP-445-145-I 006</b>	
VOLUME	IIB
SECTION	D
REV. NO.	03
DATE:	02.06.2022
SHEET	4 OF 7

SI. No.	Component / operation	Characteristics Checked	* Category	Type/Method of Check	Extent of Check	Reference documents	Acceptance Norms	Format of Records	Agency \$			Remarks
									P	W	V	
3.3	Seat leakage test for completed valve	Seat Leakage	MA	Pneumatic Test	100%	FCI-70.2	FCI-70.2	Test Certificate	2	1,4 	1,4	Refer Note-4
4.0	<b>OPERATION TEST ON COMPLETED VALVE (Final inspection)</b>	1. Valve Travel	MA	Measurement	100%	Approved drg. / data sheet 	Approved drg. / data sheet	Test Report	2	1,4 	1,4	Refer Note-4
		2. Opening/Closing time	MA	Measurement	100%	Approved drg. / data sheet 	Approved drg. / data sheet	Test Report	2	1,4 	1,4	Refer Note-4
		3. Linearity/cam characteristic	MA	Measurement	100%	Approved drg. / data sheet 	Approved drg. / data sheet	Test Report	2	1,4 	1,4	Refer Note-4
		4. Repeatability	MA	Measurement	100%	Mfr. Procedure 	Approved drg. / data sheet	Test Report	2	1,4 	1,4	Refer Note-4
		5. Hysteresis	MA	Measurement	100%	Mfr. Procedure	Approved drg. / data sheet	Test Report	2	1,4 	1,4	Refer Note-4
		6. Sensitivity	MA	Measurement	100%	Mfr. Procedure	Approved drg. / data sheet	Test Report	2	1,4 	1,4	Refer Note-4
		7. Accuracy (Overall)	MA	Measurement	100%	Mfr. Procedure	Approved drg. / data sheet	Test Report	2	1,4 	1,4	Refer Note-4
		8. Control Valve characteristics / CV Test	MA	◆ Measurement (Press. vs. discharge and discharge vs. opening 0-100% in steps of 10%)	One per type	Mfr. Procedure	Approved drg. / data sheet	Test Certificate	2	--	1,4	◆ Size = Body & port size Or Body size & CV for non std port. Refer Note 1.

LEGEND: \* CR - Critical characteristics    RT- Radiographic Test    PT – Dye penetrant Test    \$ P - Agency Performing the Test.    1 - BHEL    4 - WBPDCI

MA - Major characteristics    UT – Ultrasonic Test    MT- Magnetic Test    W - Agency Witnessing the Test.    2 - Vendor    /WBPDCI TPIA

MI - Minor characteristics    V - Agency Verifying the Test.    3 - Sub-vendor





**QUALITY PLAN  
FOR  
CONTROL VALVE (PNEUMATIC)**

QUALITY PLAN NO.: <b>PE-QP-445-145-I 006</b>	
VOLUME	IIB
SECTION	D
REV. NO.	03
DATE:	02.06.2022
SHEET	5 OF 7

Sl. No.	Component / operation	Characteristics Checked	* Category	Type/Method of Check	Extent of Check	Reference documents	Acceptance Norms	Format of Records	Agency §			Remarks
									P	W	V	
		9. Operation of limit switch & solenoids and other accessories	MA	Function	100%	Mfr. Procedure	Approved drg. / data sheet	Test Report	2	1,4 	1,4	On assembled valve Refer Note-4
		10. Overall dimensions	MI	Visual and dimensional	100%	Approved drg. / data sheet	Approved drg. / data sheet	Records	2	1,4 	1,4	Refer Note-4
		11. Pre defined valve position in case of air failure	MA	Visual	100%	Approved drg. / data sheet	Approved drg. / data sheet	Test Certificate	2	1,4 	1,4	
		12. Cleanliness, painting, stamping (for direction of flow), Tag No.	MA	Visual and dimensional, paint thickness	100%	Mfr. Procedure	Approved drg. / data sheet	Test Certificate	2	1,4 	1,4	
		13. Surface Quality	MA	Visual	100%	ANSI/ MSS-SP-55	ANSI/ MSS-SP-55	Test Certificate	3/2	--	2,1,4	
<b>5.0</b>	<b>AUXILIARY ITEMS (Performance test of auxiliary items shall be performed on the completely assembled valve)</b>											
5.1	Positioner	Overall leakage after assembly including Nozzles leakage	MA	Leak Test (in the steady state input signal)	100 %	Mfr. Standard	No leakage	Test Certificate 	3/2	---	1,4 	Certificate of Conformance (C.O.C)
5.2	Air filter regulator	1. Normal air consumption	MA	Measurement	Each type	Mfr. Standard	No leakage	Test Certificate 	3/2	---	1,4 	(C.O.C)
		2. Overall leakage	MA	Visual (soap solution)	100 %	Mfr. Standard	No leakage	Test Certificate 	3/2	---	1,4 	(C.O.C)

















LEGEND:	* CR - Critical characteristics	RT- Radiographic Test	PT – Dye penetrant Test	§ P - Agency Performing the Test.	1 - BHEL	4 - WBPDCI
	MA - Major characteristics	UT – Ultrasonic Test	MT- Magnetic Test	W - Agency Witnessing the Test.	2 - Vendor	/WBPDCI TPIA
	MI - Minor characteristics			V - Agency Verifying the Test.	3 - Sub-vendor	



PEM :: C&I

## QUALITY PLAN FOR CONTROL VALVE (PNEUMATIC)

QUALITY PLAN NO.: PE-QP-445-145-I 006	
VOLUME	IIB
SECTION	D
REV. NO.	03
DATE:	02.06.2022
SHEET	6 OF 7

Sl. No.	Component / operation	Characteristics Checked	* Category	Type/Method of Check	Extent of Check	Reference documents	Acceptance Norms	Format of Records	Agency \$			Remarks
									P	W	V	
5.3	Air lock relay	Performance Test	MA	Leakage test	100%	Mfr. Standard	No leakage	Test Certificate 	3/2	---	1,4 	(C.O.C)
5.4	Electronic position transmitter(not applicable if provided integral to smart positioner)	1. Accuracy	MA	Operation	100%	Approved data sheet /	Approved data sheet /	Test Certificate 	2	1	1,4 	(C.O.C)
5.5	Current to Pneumatic converter(not applicable for smart positioner)	1. Physical Verification Make/Model	MA	Visual	100%	Approved drg. / data sheet	Approved drg. / data sheet	Test Certificate 	2	---	1,4 	(C.O.C)
		2. Degree of Protection	MA	IP/NEMA test	Each type	Relevant Standard	Relevant Standard	Test Certificate 	3	---	1,4 	(C.O.C)
		3. Linearity	CR	Measurement	100%	Approved drg. / data sheet /	Approved drg. / data sheet /	Test Certificate 	2	---	1,4 	(C.O.C)
		4. Hysteresis	CR	Measurement	100%	Approved drg. / data sheet /	Approved drg. / data sheet /	Test Certificate 	2	---	1,4 	(C.O.C)
5.6	Smart Positioner (As Applicable)	1. Physical Verification Make/Model	MA	Visual	100%	Approved drg. / data sheet	Approved drg. / data sheet	Test Certificate 	2	---	1,4 	(C.O.C)
		2. Degree of Protection	MA	IP/NEMA test	Each type	Relevant Standard	Relevant Standard	Test Certificate 	3	---	---	

**LEGEND:**

\* CR - Critical characteristics  
MA - Major characteristics  
MI - Minor characteristics

RT- Radiographic Test  
UT - Ultrasonic Test

PT - Dye penetrant Test  
MT- Magnetic Test

\$ P - Agency Performing the Test.  
W - Agency Witnessing the Test.  
V - Agency Verifying the Test.

1 - BHEL  
2 - Vendor  
3 - Sub-vendor

4 - WBPDCI  
/WBPDCI TPIA





**QUALITY PLAN  
FOR  
CONTROL VALVE (PNEUMATIC)**

QUALITY PLAN NO.: <b>PE-QP-445-145-I 006</b>	
VOLUME	IIB
SECTION	D
REV. NO.	03
DATE:	02.06.2022
SHEET	7 OF 7

Sl. No.	Component / operation	Characteristics Checked	* Category	Type/Method of Check	Extent of Check	Reference documents	Acceptance Norms	Format of Records	Agency \$			Remarks
									P	W	V	
		3. Linearity	CR	Measurement	100%	Approved drg. / data sheet /	Approved drg. / data sheet /	Test Certificate 	2	---	1,4 	(C.O.C)
		4. Hysterisis	CR	Measurement	100%	Approved drg. / data sheet /	Approved drg. / data sheet /	Test Certificate 	2	---	1,4 	(C.O.C)
		5. Calibration with Hand Held Communicator	MA	Measurement	Each type	Mfr. Standard	Mfr. Standard	Test Certificate 	2	---	1,4 	(C.O.C)
<b>6.0</b>	<b>PAINTING</b>	Soundness of Painting	MA	Visual and Measurement	100%	Mfr. Standard	Mfr. Standard	Inspection Report	2	---	1 	Refer Note-2
<b>7.0</b>	<b>PACKING</b>	Soundness of Packing against transit damage	MA	Visual	100%	Mfr. Standard	Mfr. Standard	Inspection Report	2	-	1 	Refer Note-3

**NOTES:**

1. In case valid CV test certificate for a similar control valve(same size, same CV, same trim characteristics) is not submitted to BHEL by the vendor, CV test shall be conducted at FCRI/Any govt. approved laboratory.
2. In the absence of BHEL spec. for painting, vendor to obtain BHEL's approval on their painting specification / procedure.
3. Sea worthy packing shall be provided, if called for in the Data sheets.
4. The quantum of check shall be 100% for manufacturer and 10% or 1 no. for each type, size and model no. for BHEL/BHEL nominated inspection agency/ WBDCL/ WBDCL TPIA.
5. IBR certificates in Form III-C shall be submitted if called for in the specification/datasheet.
6. Copies of all TC's(Test Certificates) for materials duly correlated with Heat Nos., TC's for electrical items and mechanical tests(Leak/Operation), C.O.C's(Certificates of Conformance) shall be submitted to BHEL for verification and acceptance.

LEGEND:	* CR - Critical characteristics MA - Major characteristics MI - Minor characteristics	RT- Radiographic Test UT - Ultrasonic Test	PT - Dye penetrant Test MT- Magnetic Test	\$ P - Agency Performing the Test. W - Agency Witnessing the Test. V - Agency Verifying the Test.	1 - BHEL 2 - Vendor 3 - Sub-vendor	4 - WBDCL /WBDCL TPIA
---------	---	---	--	---	--	--------------------------



## Sagardighi Thermal Power Project

1 x 660 MW Unit No. 5, Phase-III

Technical specification for  
**Control Valve with Accessories - Feed Control Valve**  
(Pneumatically Operated)

SPEC NO.: PE-TS-445-145-1801A

DOCUMENT NO.

VOLUME II B

SECTION C

ISSUE NO.

REV. NO. 00

DATE: 23.01.2023

# SECTION – C

## BILL OF QUANTITY-MAIN SUPPLY

	<b>Sagardighi Thermal Power Project</b> 1 x 660 MW Unit No. 5, Phase-III  Technical specification for <b>Control Valve with Accessories - Feed Control Valve</b> (Pneumatically Operated)	SPEC NO.: PE-TS-445-145-1801A	
		DOCUMENT NO.	
		VOLUME	II B
		SECTION	C
		ISSUE NO.	
REV. NO. 00	DATE: 23.01.2023		

## **BILL OF QUANTITY-MAIN SUPPLY**

**[A] CONTROL VALVES COMPLETE WITH POSITIONER AND ALL ACCESSORIES MOUNTED, TUBED AND TERMINATED ON JB**

[A]	MAIN SUPPLY		
S.NO.	TAG NO	DESCRIPTION	TOTAL QTY.
1	FDV-14	LOW LOAD FEED CONTROL VALVE	1 NO.
<b>[B]</b>	<b>1/4 " SS TUBING (25 METER FOR EACH TAG)</b>		<b>25 METER</b>
<b>[C]</b>	<b>SS FITTINGS- FOR EACH TAG</b>		
1	SS FITTINGS for connection to Air Filter Regulator- FOR EACH TAG		<b>1 LOT</b>
2	SS FITTINGS for connection to Air Lock Relay- FOR EACH TAG		<b>1 LOT</b>
3	SS FITTINGS for connection to IA Header Isolation Valve - FOR EACH TAG		<b>1 LOT</b>
4	SS EQUAL TEE - FOR EACH TAG		<b>1 LOT</b>
5	SS 1/2 " NPT(M) X 1/4 " OD TUBE CONNECTOR- FOR EACH TAG		<b>1 LOT</b>
<b>[D]</b>	<b>VALVE DIAGNOSTIC AND CONFIGURATION SOFTWARE (FOR ALL TAGS)</b>		<b>1 LOT</b>
<b>[E]</b>	<b>CV TEST CHARGE</b>		<b>1 NO.</b>



## Sagardighi Thermal Power Project

1 x 660 MW Unit No. 5, Phase-III

Technical specification for  
**Control Valve with Accessories - Feed Control Valve**  
(Pneumatically Operated)

SPEC NO.: PE-TS-445-145-I801A

DOCUMENT NO.

VOLUME II B

SECTION C

ISSUE NO.

REV. NO. 00

DATE: 23.01.2023

# SECTION – C

## BILL OF QUANTITY-SPARES

	<b>Sagardighi Thermal Power Project</b> 1 x 660 MW Unit No. 5, Phase-III  Technical specification for <b>Control Valve with Accessories - Feed Control Valve</b> (Pneumatically Operated)	SPEC NO.: <b>PE-TS-445-145-1801A</b>	
		DOCUMENT NO.	
		VOLUME	II B
		SECTION	C
		ISSUE NO.	
		REV. NO. 00	DATE: 23.01.2023

## LIST OF COMMISSIONING SPARES

S.NO.	ITEM DESCRIPTION	QUANTITY PER UNIT
1	Gaskets	One(1) set with each control valve tag
2	Gland Packing	One(1) set with each control valve tag

## LIST OF MANDATORY SPARES

S.NO.	ITEM DESCRIPTION	QUANTITY PER UNIT
1	Bonnet Seal	2Set (one set means complete replacement required for one Valve)
2	Gland Packing	3Set (one set means complete replacement required for one Valve)
3	Plug, Seat, Cage, Stem etc.	1Set (one set means complete replacement required for one Valve)
4	Retainer Ring, Seal Ring etc.	1Set (one set means complete replacement required for one Valve)
5	Actuator Seal Kit for Pneumatic Cylinder	2Nos.
6	Smart Positioner of the Valve	1No.
7	Position Feedback Transmitter (applicable if it is not integral with the Smart Positioner)	1No.

### NOTE

- Wherever quantity has been specified as percentage (%), the quantity of mandatory spares to be provided by contractor shall be the specified percentage (%) of the total population of the plant. In case the quantity so calculated happens to be a fraction, the same shall be rounded off to next higher whole number.
- Wherever the quantities have been indicated for each type, size, thickness, material, radius, range etc., these shall cover all the items supplied and installed and the breakup for these shall be furnished in the bid. In case spares indicated in the list are not applicable to the particular design offered by the bidder, the bidder should offer spares applicable to offered design with quantities generally in line with the approach followed in the above list.



## Sagardighi Thermal Power Project

1 x 660 MW Unit No. 5, Phase-III

Technical specification for  
**Control Valve with Accessories - Feed Control Valve**  
(Pneumatically Operated)

SPEC NO.: PE-TS-445-145-1801A

DOCUMENT NO.

VOLUME II B

SECTION D

ISSUE NO.

REV. NO. 00

DATE: 23.01.2023

## SECTION – D

- EQUIPMENT SPECIFICATION  
(PES-145-06)
- SPECIFICATION FOR SMART POSITIONER  
(PES-145-06A)
  - HOOK-UP DIAGRAM (PES-145-06B)
- GUIDELINES FOR PACKING (PES-145-06C)
  - SUB-VENDOR LIST



## Sagardighi Thermal Power Project

1 x 660 MW Unit No. 5, Phase-III

Technical specification for  
**Control Valve with Accessories - Feed Control Valve**  
 (Pneumatically Operated)

SPEC NO.: PE-TS-445-145-1801A

DOCUMENT NO.

VOLUME II B

SECTION

ISSUE NO.

REV. NO. 00

DATE: 23.01.2023

## SECTION – D

### EQUIPMENT SPECIFICATION (PES-145-06)



**SPECIFICATION FOR CONTROL VALVE  
(WITH PNEUMATIC / ELECTRIC ACTUATOR)**

SPECIFICATION NO.: PE-TS-XXX-145-I104	
DOCUMENT NO.: PES – 145 - 06	
VOLUME	II B
SECTION	D
ISSUE NO.	2
REV. NO.	01
DATE	: 16.03.2019
SHEET	29 OF 51

**1.0 SCOPE**

- 1.1 This specification covers the Design, Manufacture, Inspection and Testing at the manufacturer's works, proper packing for transportation and delivery to site of Control valve (with Pneumatic/Electric Actuator as identified in the datasheet-A) for use in Utility/Captive Power Station/Combined Cycle Station.
- 1.2 Expander/Reducer between valve body & pipe shall be in BHEL's scope of supply. However, any other expander/reducer required shall be in bidder's scope of supply.

**2.0 CODES AND STANDARDS**

- 2.1 As a minimum requirement, the latest revision/version of the following (or equivalent) standards shall be complied as a minimum requirement :-

Indian Boiler Regulation (IBR)	:	
Allowable Seat leakage	:	FCI-70.2
Pressure & Temperature ratings	:	ANSI-B16.34
Enclosure class	:	IEC-144 / NEMA / IS-13947
Control Valves Sizing	:	ISA S-75
Electric Motor operated Actuators	:	IS-9334

**3.0 TECHNICAL REQUIREMENTS**

The Control valve, Actuator and the accessories shall be suitable for continuous operation under an ambient temperature of 0-60°C and Relative Humidity of 0-95% unless specified otherwise in volume IIB Section-B or Section-C.

**3.1 Control Valve**

The control valve shall be suitably designed for the process operating conditions and system characteristics as specified in the Data Sheet-A.

- 3.1.1 The control valve shall be of globe/angle body design, as per datasheet, with single port. Valve trim shall be cage guided balanced type for valve sizes  $\geq 3"$  and above. The valve trim shall be suitable for quick replacement without any cutting or welding. Anti-cavitation trims shall be provided for valves with cavitation service and hardened trims for flashing services.
- 3.1.2 The trim material and body material has been specified in the Datasheet-A. Bidder to offer body material and trim material combination as per the datasheet. Wherever there is a deviation from the datasheets, bidder to furnish the documentary proof for confirming superior trim material/body material selection along with their offer. BHEL/Customer reserves the right to accept/reject any variation in the specification.
- 3.1.3 Not used
- 3.1.4 Asbestos shall not be used for the packing or any other component.

	<b>SPECIFICATION FOR CONTROL VALVE (WITH PNEUMATIC / ELECTRIC ACTUATOR)</b>	SPECIFICATION NO.: PE-TS-XXX-145-I104		
		DOCUMENT NO.: PES – 145 - 06		
		VOLUME	II B	
		SECTION	D	
		ISSUE NO.	2	
		REV. NO.	01	DATE : 16.03.2019
		SHEET	30	OF 51

3.1.5 The valve bonnet and packing shall be suitable for the service conditions as in Data Sheet-A. Gland sealed type bonnets are not acceptable. Double packing is mandatory for applications involving vacuum service. For valves where downstream is subjected to vacuum, flow action shall be "flow to close" (over the seat). Bonnets having Teflon packing shall have valve stem finished to 2-4 microns. Packing material requiring lubrication will not be acceptable.

Type of bonnet shall be according to the service condition. Extension bonnets shall be provided when the maximum temperature of the flowing fluid is greater than 280 or unless otherwise specified.

Cast Steel (CS) yokes shall be offered for CEP Minimum Recirculation valve/GSC minimum recirculation control valve. Cast Iron (CI) yokes are not acceptable for this service.

3.1.6 The valve end connection as specified in Data Sheet-A shall conform to ANSI B16.25 for Butt Weld connection, ANSI B16.11 for Socket Weld connection and ANSI B16.5 for flanged ends. Tolerances on end to end, center to center, center to face shall be in accordance with ASME B16.10. The end connections shall be Socket Welded for sizes up to 50 NB and Butt Welded for sizes above 50 NB.

3.1.7 The valve seat leakage shall be as per FCI-70.2. The leakage class shall be as per Data Sheet-A.

3.1.8 The valve body shall have the direction of flow embossed on all valves.

3.1.9 The sizing shall conform to the requirements of ISA S75.01, and the valve capacity shall be selected so as to meet the following:

Valve with Linear Characteristic	-	Normal Flow (Design Point)	:	70-75% valve lift.
	-	Max. Flow	:	90% valve lift.
	-	Min. Flow	:	>10% valve lift.

Valve with Equipercentage Characteristic	-	Normal Flow (Design Point)	:	75-85% valve lift.
	-	Max. Flow	:	90% valve lift.
	-	Min. Flow	:	>10% valve lift.

ON/OFF Quick open Characteristic	-	1.1 times the CV calculated on the basis of maximum flow condition.
----------------------------------	---	---

The valve offered shall be capable of handling 120 % of the required maximum flow.

3.1.10 Calculation for valve sizing, velocity and noise shall be subject to purchaser's approval during contract stage. However responsibility of proper selection and design for the duties specified lies with the vendor. Any modifications required to be done on the valves or actuators & accessories to achieve satisfactory performance of the control system shall be done without any commercial & delivery implication.

3.1.11 The valve outlet velocities shall be limited to the following values, unless otherwise specified in the Data sheet-A.

- |      |                  |    |  |
|------|------------------|----|--|
| i)   | Liquid service   | <= | 8 m/sec                                      |
| ii)  | Steam service    | <= | 150 m/sec                                    |
| iii) | Flashing service | <= | 50% of sonic velocity for flashing services. |

3.1.12 For flashing duty, trim design shall be such that the vapour bubbles are kept away from valve body.

3.1.13 For cavitation service, the trim design shall be of multistage pressure drop type, so as to avoid cavitation altogether, instead of keeping cavitation away from valve parts.

	<b>SPECIFICATION FOR CONTROL VALVE (WITH PNEUMATIC / ELECTRIC ACTUATOR)</b>	SPECIFICATION NO.: PE-TS-XXX-145-I104		
		DOCUMENT NO.: PES – 145 - 06		
		VOLUME	II B	
		SECTION	D	
		ISSUE NO.	2	
		REV. NO.	01	DATE : 16.03.2019
		SHEET	31	OF 51

- 3.1.14 The equivalent weighted sound level measured at 1.5 metre above floor level in elevation and 1 metre horizontally from the control valve expressed in decibels to a reference of 0.0002 microbar shall not exceed 85 dBA (without pipe insulation). The offer shall include noise prediction calculations for each valve.
- 3.1.15 In case of predicted noise level above 85 dBA, same shall be brought down to acceptable noise level i.e. below 85 dBA through Source treatment (proper valve trim & valve body selection). Path treatment (LNP/ Diffuser/ Cartridge/ Silencer etc.), if any shall be subject to Customer's/Owner's approval.
- 3.1.16 In case of wrong selection/mal operation of valve and for associated actuator during guarantee period, the vendor shall replace the valve suitably with a modified/new valve of design as approved by purchaser and all the expenses for replacement, rectification/modification including transportation both ways will be at vendor's expenses.
- 3.2 **ACTUATORS-** The control valves shall be operated either pneumatically (with pneumatic actuator) or electrically (with electric actuator).  
For pneumatic actuator, clause nos. 3.2.1 through 3.2.6 to be followed.
- 3.2.1 **Pneumatic Actuator**
- The actuator shall be designed for a thrust of 120% of valve's shut-off pressure at an airline supply pressure of 5 Kg/Sq. cm.
- The pneumatic actuators shall be employed for modulating or open/close duty, as specified in Data Sheet-A. The bidder shall be responsible for proper selection and sizing of valve actuators in accordance with the pressure drops, shut off pressure and valve travel.  
The pneumatic spring opposed diaphragm actuator or piston actuator as the case may be for modulating duty shall be capable of positioning the associated valve at desired opening for all the operating conditions specified.
- 3.2.2 The pneumatic actuator for open/close duty shall be suitable for fast opening/closing of the associated valve.
- 3.2.3 The actuator design shall allow valve assembly to be mounted at 45° inclination on either side in the vertical plane.
- 3.2.4 The actuators shall be suitably sized to ensure that the associated valve travel time from full open to full closed position and vice versa is less than 10 seconds or as specified in the datasheet under the most stringent service conditions.
- 3.2.5 The actuator's hand wheel shall have OPEN & CLOSE direction marking and clockwise rotation as viewed from front shall close the valve.
- 3.2.6 Each actuator shall be provided with a mechanical pointer attached to stem, moving over a graduated scale with markings, for OPEN, 25%, 50%, 75%, CLOSE positions.

	<b>SPECIFICATION FOR CONTROL VALVE (WITH PNEUMATIC / ELECTRIC ACTUATOR)</b>		SPECIFICATION NO.: PE-TS-XXX-145-I104		
			DOCUMENT NO.: PES – 145 - 06		
			VOLUME	II B	
			SECTION	D	
			ISSUE NO.	2	
			REV. NO.	01	DATE : 16.03.2019
			SHEET	32	OF 51

### 3.3 Accessories for Control valve with Pneumatic Actuator

The bidder shall offer all the accessories as specified in the Data Sheet - A for the Pneumatic Actuators under modulating or OPEN/CLOSE duty. The accessories specified shall be supplied duly mounted on the valve actuator and piped with PVC covered copper/ SS tube and flare-less brass/ SS fittings etc. as per the hook up diagram (Refer drawing no. PES-145

3.4 **Painting** of the control valve assembly shall be as per the Painting Specification attached elsewhere in this technical specification. In the absence of specification for painting, vendor to submit their standard painting procedure for painting for BHEL's approval. Epoxy based paint (corrosion-resistant) to be provided for control valves for coastal environment.

### 3.5 Sub-vendor list –

The sub-vendors shall be as per the list enclosed elsewhere in this specification. In case the bidder proposes sub-vendors other than those listed in the specification, the same shall be subject to BHEL's/Customer's approval.

## 4.0 TESTING AND INSPECTION

4.1 The testing and inspection of the equipment/items shall be in line with the approved QAP

4.2 The cost of all tests as per the approved QAP will be deemed to have been included in the bid.

4.3 In case, the bidder is supplying the valve from outside India, the third party inspection shall be arranged and considered by the bidder in their offer.

## 5.0 SPARES AND CONSUMABLES

### 5.1 Start-up/Commissioning Spares

The bidder shall supply all the start-up/commissioning spares as per the BOQ given in the technical specification.

### 5.2 Mandatory Spares

The bidder shall supply all the mandatory spares as per the BOQ given in the technical specification.

## 6.0 DRAWINGS AND DOCUMENTS

### 6.1 The bidder shall furnish the following documents along with the bid: 4 Sets

6.1.1 Data sheet-B, completely filled-up along with all enclosures.

~~6.1.2 Schedule of prices in attached format (VOL. III).~~

6.1.3 Quality Plan duly signed & stamped.

6.1.4 All relevant Catalogs with detailed technical information.

	<b>SPECIFICATION FOR CONTROL VALVE (WITH PNEUMATIC / ELECTRIC ACTUATOR)</b>		SPECIFICATION NO.: PE-TS-XXX-145-I104		
			DOCUMENT NO.: PES – 145 - 06		
			VOLUME	II B	
			SECTION	D	
			ISSUE NO.	2	
			REV. NO.	01	DATE : 16.03.2019
			SHEET	33	OF 51

**6.2 The successful bidder shall furnish the following documents to BHEL during the contract stage viz. after the award of contract:**

5 sets of the following documents for approval + 2 sets of CDs:

**6.2.1 CONTROL VALVE DOCUMENTS (Drg. No. PE-VO-XXX-145-I004) including the following:-**

- (a) Assembly (dimensional) drawings.
- (b) Valve Edge preparation details.
- (c) Data sheet-C completely filled-up.
- (d) Hook-up diagram of Control Valve with Actuator & Accessories.
- (e) Valve & Actuator assembly dimensional drawings with weights.
- (f) All calculations like CV, Noise Level, Valve Outlet Velocity, Actuator sizing etc.
- (g) All relevant catalogues for models of the valves as well as accessories finalized.

**6.2.2 QUALITY PLAN (Drg. No. PE-QP-XXX-145-I006) duly signed and stamped.**

**6.3 Final documentation:**

Documents / drawings to be furnished by the successful bidder shall be as follows:  
15 sets with 6 CD-ROMS of:-

- 6.3.1 Category I & IV approved CONTROL VALVE DOCUMENTS
- 6.3.2 Test certificates
- 6.3.3 Operation & maintenance manuals for Control Valve, Actuator and all accessories

**7.0 MARKING AND PACKING**

**7.1 Marking**

A stainless steel metal nameplate should be permanently fixed on each equipment giving its tag number and technical specifications.

**7.2 Packing**

All equipment / materials shall be suitably packed and protected for the entire period of dispatch, storage and erection against impact, abrasion, corrosion, incidental damage due to vermin, sunlight, high temperature, rain, moisture, humidity, dust, sea water spray (where applicable) as well as rough handling and delays in transit and storage in open. Guidelines for packing are enclosed (Refer specification no. PES-145-06C).

**8.0 APPLICABLE DATA SHEET FORMS**

This document shall be read with one or more of the following data sheet forms:

- Data sheet A&B for Control Valve with Pneumatic Actuator : Data sheet no. PES-145-06-DS1-1
- Data sheet C for Control Valve with Pneumatic Actuator : Data sheet no. PES-145-06-DS2-1



## Sagardighi Thermal Power Project

1 x 660 MW Unit No. 5, Phase-III

Technical specification for  
**Control Valve with Accessories - Feed Control Valve**  
(Pneumatically Operated)

SPEC NO.: PE-TS-445-145-1801A

DOCUMENT NO.

VOLUME II B

SECTION D

ISSUE NO.

REV. NO. 00

DATE: 23.01.2023

### SECTION-D

## SPECIFICATION FOR SMART POSITIONER (PES-145-06A)

	<b>SPECIFICATIONS FOR MICROPROCESSOR BASED ELECTRONIC POSITIONER (SMART )</b>	SPECIFICATION NO.: PE-TS-XXX-145-1104	
		DOCUMENT NO.: PES-145-06A	
		VOLUME. II B	
		SECTION D	
		ISSUE NO. 2 , REV.01	DATE : 16.03.19
SHEET 35 OF 51			

## 1.0 Electrical

Input Signal	4-20mA
Power Supply	Loop Powered from the output card of Control System (12-30 V DC)
Hart Protocol	Compatibility For Remote Calibration & Diagnostic (Super-Imposed HART Signal On Input Signal (4-20mA)
Valve Position Feedback (4-20mA)	Position Sensing 4-20mA O/P Signal For Control System To Be Provided. If non contact type of Position feedback signal is required, Position transmitter to be separately provided.

## 2.0 Environment

Operating Temperature	0 To 60 Deg C
Humidity	0-95%
Protection Class	IP-65 (Minimum)

## 3.0 Software For Configuration & Diagnostic

Software	Windows Based Software, Software Shall Meet The Requirement For Configuration, Diagnostics, Calibration And Testing Of the Actuator. Valve positioning timing, actuator leakage, and Valve Wear & tear, fault alarm to be offered as a minimum. Easily up gradable with same hardware and compatible with any HART management systems / AMS.
Diagnostic/Test Features (Optional)	Advanced Diagnostic Features Like Stroke On Line Partial Closure Test, Valve Signature Analysis (Online graphical representation ), Step Response Test, Valve Friction/Jamming Detection Etc To Be Provided.

	<b>SPECIFICATIONS FOR MICROPROCESSOR BASED ELECTRONIC POSITIONER (SMART )</b>	SPECIFICATION NO.: PE-TS-XXX-145-I104	
		DOCUMENT NO.: PES-145-06A	
		VOLUME. II B	
		SECTION D	
		ISSUE NO. 2 , REV.01	DATE : 16.03.19
SHEET 36 OF 51			

Factory Valve Signature Tests Reports (Pr Vs Valve Travel And Travel Vs I/P Signal) Are To Be Provided.

Hardware                      PC                      For Configuration/Software (OPTIONAL)

Test Certificates                      Test Certificates As Per Manufacture Standard/Relevant Standard Are To Be Submitted.

Configuration / Remote Calibration, Auto & Manual Calibration Shall Be Possible.

**4.0      Modes**

Valve Action	Direct & Reverse, Valve Action. ( Same positioner for Single Acting or Double Acting And no separate relays required for changing from Single acting to double).
Flow Characterization	Possible to fit valve characteristic curve linear & Equal percentage
Fail Safe/Fail Freeze (Optional)	Fail Safe/Fail Freeze feature is to be provided.

**5.0      Performance**

Characteristic Deviation	<=0.75% of span
Ambient temp effect	<=0.01%/Deg C or better.
Dead Band	Adjustable 0.1 to 10%.
Scan Time	10ms
Resolution	<=0.05%
Sensitivity/Linearity	0.3-0.4% of FS
Repeatability	0.32% of FS
Auto-Tune	Yes



**Sagardighi Thermal Power Project**

1 x 660 MW Unit No. 5, Phase-III

Technical specification for  
**Control Valve with Accessories - Feed Control Valve**  
(Pneumatically Operated)

SPEC NO.: PE-TS-445-145-1801A

DOCUMENT NO.

VOLUME II B

SECTION D

ISSUE NO.

REV. NO. 00

DATE: 23.01.2023

**SECTION-D****HOOK-UP DIAGRAM (PES-145-06B)**

**BHEL  
PEM**

**DATA SHEET FOR CONTROL VALVES  
(WITH PNEUMATIC ACTUATOR)**

SPECIFICATION NO.: PE-TS-445-145-1104

VOLUME

SECTION

REV. NO. 03

DATE : 17.05.2022

SHEET

60

OF 62

**STANDARD CONTROL VALVE HOOK-UP DIAGRAM  
(WITH SMART POSITIONER)**

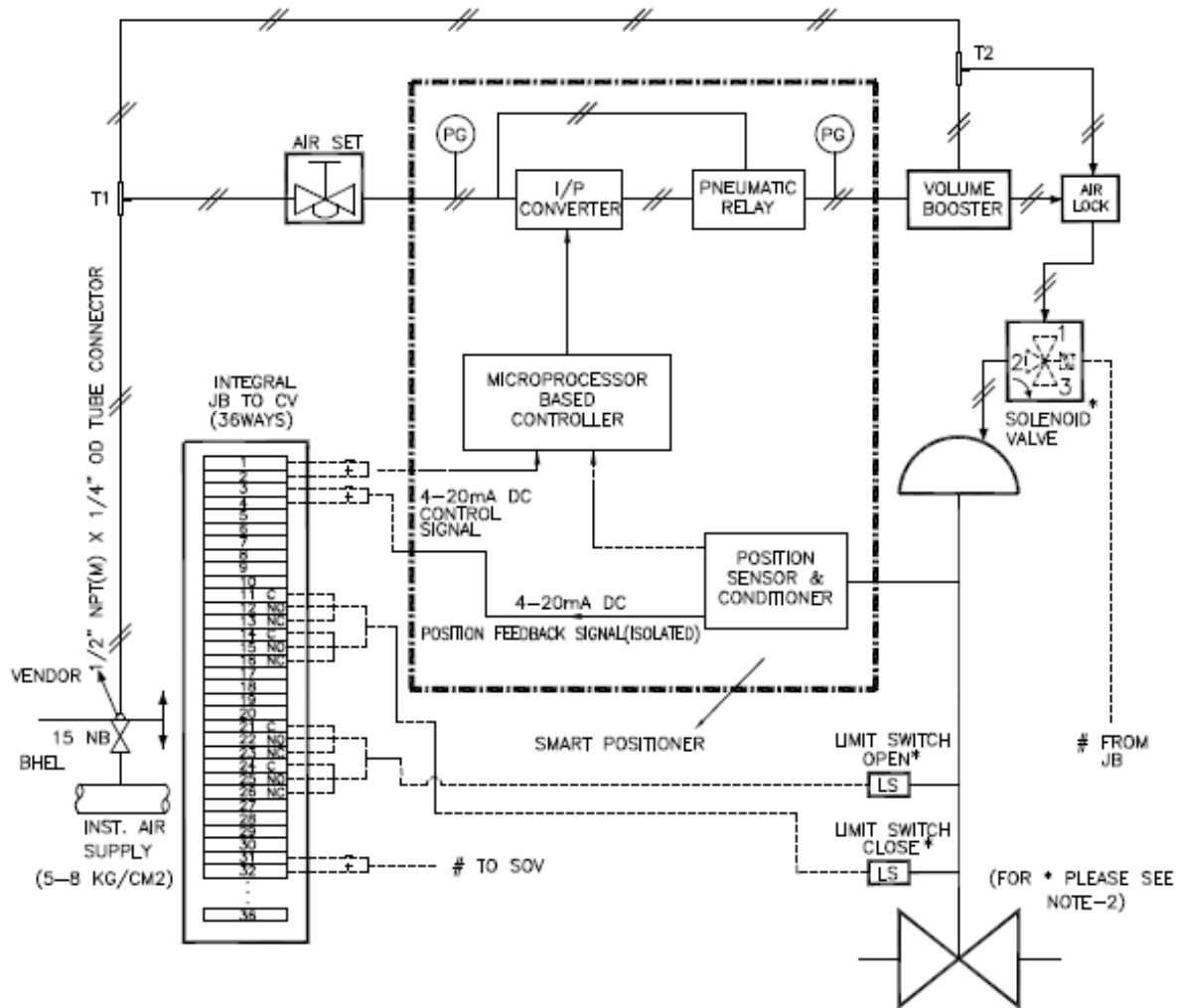

**NOTES :-**

1. POSITION OF EACH VALVE ON SUPPLY AIR FAILURE / ELECTRICAL SIGNAL FAILURE SHALL BE AS PER SPECIFICATION / DATA SHEET-A
2. SOLENOID VALVE & LIMIT SWITCHES WILL BE PROVIDED ONLY FOR CONTROL VALVES IF INDICATED IN RESPECTIVE DATA SHEETS.
3. SOLENOID VALVES PORTS CONDITION:  
PORT 1 AND 2 SHALL BE CONNECTED UNDER DE-ENERGISED CONDITION.  
PORT 2 AND 3 SHALL BE CONNECTED UNDER ENERGISED CONDITION.
4. PRESSURE GAUGES REQUIRED FOR AIR SUPPLY & OUTPUT(S).
5. MOUNTING ACCESSORIES AS REQUIRED.
6. POSITION FEEDBACK SIGNAL SHALL BE 2 WIRE 4-20mA ISOLATED SIGNAL.
7. JB TERMINALS SHALL BE CAGE CLAMP TYPE SUITABLE FOR 2.5 SQ. MM COPPER WIRE. EXTERNAL CONNECTION, OF PLUG IN TYPE OR THROUGH CABLE GLAND, SHALL BE AS PER ACCESSORY DATA SHEET.
8. ALL APPLICABLE ACCESSORIES SHALL BE PROVIDED AS INDICATED IN THE INDIVIDUAL CONTROL VALVE DATA SHEET / ACCESSORIES DATA SHEET.
9. 12 METERS 1/4" PVC COATED COPPER / SS TUBING (AS PER ACCESSORIES DATA SHEET) & 1 SET OF FITTINGS TO BE SUPPLIED FOR EACH CONTROL VALVE FOR CONNECTION TO ISOLATION VALVE AT INST AIR HEADER ON ONE END AND TO AIR LOCK RELAY/AIR FILTER REGULATOR ON THE OTHER END. ALL THE BRASS / SS FITTINGS SHALL BE DOUBLE COMPRESSION TYPE.
10. VOLUME BOOSTER (ALONG WITH TEE-T2 AND RELATED TUBING & CONNECTORS) SHALL BE PROVIDED IF REQUIRED. AIR CONNECTION TO VOLUME BOOSTER FROM TEE-T2 SHALL BE PROVIDED.

**STANDARD CONTROL VALVE HOOK-UP DIAGRAM  
(DOUBLE ACTING PISTON ACTUATOR WITH SMART POSITIONER)**

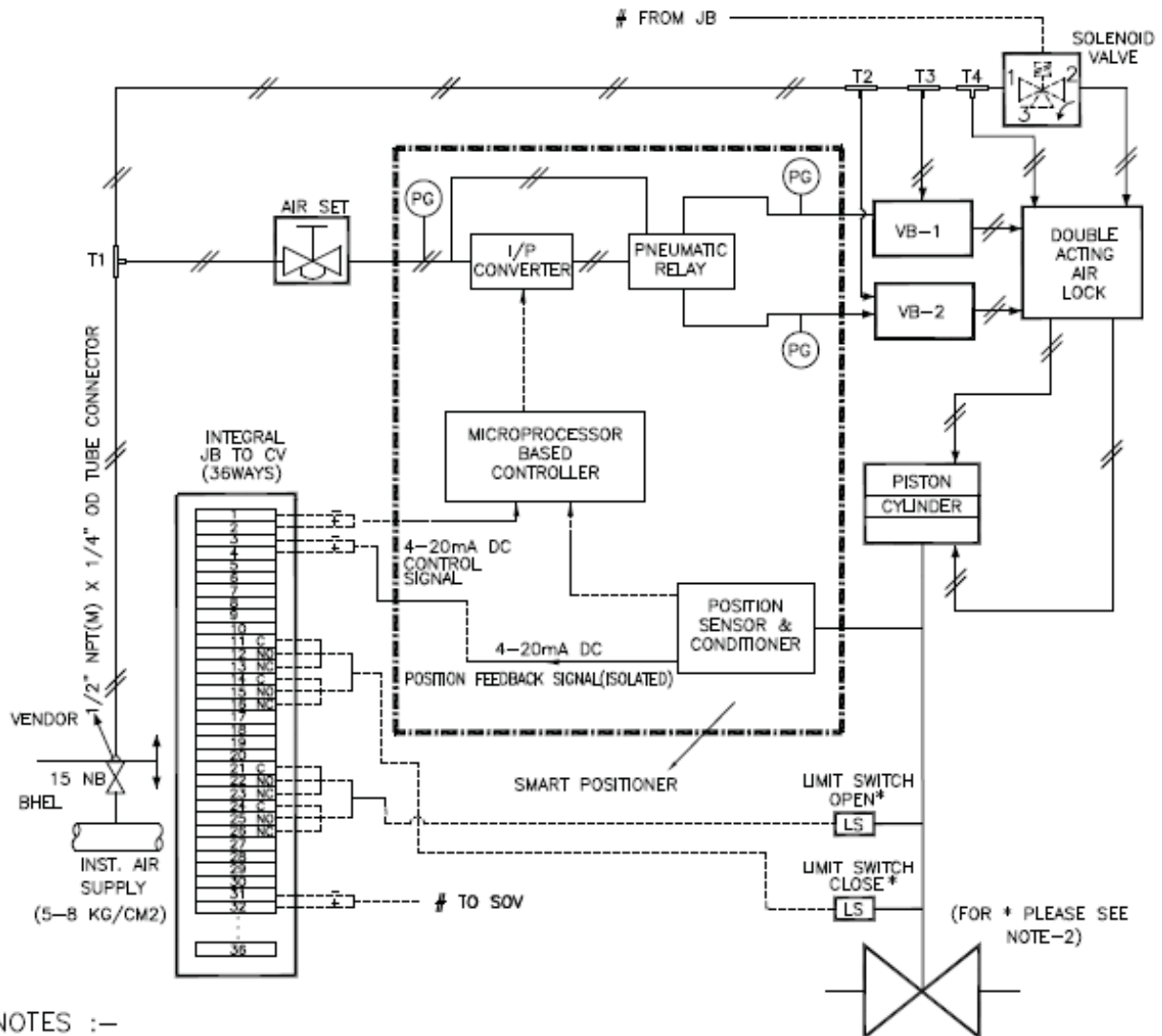

**NOTES :-**

1. POSITION OF EACH VALVE ON SUPPLY AIR FAILURE / ELECTRICAL SIGNAL FAILURE SHALL BE AS PER SPECIFICATION/DATA SHEET-A. AIR LOCK SHALL BE PROVIDED ACCORDINGLY.
2. SOLENOID VALVE & LIMIT SWITCHES WILL BE PROVIDED ONLY FOR CONTROL VALVES IF INDICATED IN RESPECTIVE DATA SHEETS.
3. SOLENOID VALVES PORTS CONDITION:  
PORT 1 AND 2 SHALL BE CONNECTED UNDER DE-ENERGISED CONDITION.  
PORT 2 AND 3 SHALL BE CONNECTED UNDER ENERGISED CONDITION.
4. PRESSURE GAUGES REQUIRED FOR AIR SUPPLY & OUTPUT(S).
5. MOUNTING ACCESSORIES AS REQUIRED.
6. POSITION FEEDBACK SIGNAL SHALL BE 2 WIRE 4-20mA ISOLATED SIGNAL.
7. JB TERMINALS SHALL BE CAGE CLAMP TYPE SLITARIF FOR 2.5 SQ. MM COPPER WIRE. EXTERNAL CONNECTION, OF PLUG IN TYPE OR THROUGH CABLE GLAND, SHALL BE AS PER ACCESSORY DATA SHEET.
8. ALL APPLICABLE ACCESSORIES SHALL BE PROVIDED AS INDICATED IN THE INDIVIDUAL CONTROL VALVE DATA SHEET / ACCESSORIES DATA SHEET.
9. 12 METERS 1/4" PVC COATED COPPER / SS TUBING (AS PER ACCESSORIES DATA SHEET) & 1 SET OF FITTINGS TO BE SUPPLIED FOR EACH CONTROL VALVE FOR CONNECTION TO ISOLATION VALVE AT INST AIR HEADER ON ONE END AND TO AIR LOCK RELAY/AIR FILTER REGULATOR ON THE OTHER END. ALL THE BRASS / SS FITTINGS SHALL BE DOUBLE COMPRESSION TYPE.
10. VOLUME BOOSTER (ALONG WITH TEE-T2 AND RELATED TUBING & CONNECTORS) SHALL BE PROVIDED IF REQUIRED. AIR CONNECTION TO VOLUME BOOSTER FROM TEE-T2 & TEE-T3 SHALL BE PROVIDED.



## Sagardighi Thermal Power Project

1 x 660 MW Unit No. 5, Phase-III

Technical specification for  
**Control Valve with Accessories - Feed Control Valve**  
(Pneumatically Operated)

SPEC NO.: PE-TS-445-145-1801A

DOCUMENT NO.

VOLUME II B

SECTION D

ISSUE NO.

REV. NO. 00

DATE: 23.01.2023

## SECTION-D

### GUIDELINES FOR PACKING (PES-145-06C)



Technical specification for  
**Control Valves with Accessories**  
(Pneumatically Operated)

SPEC NO.: PE-TS-XXX-145-I104

DOCUMENT NO.: PES-145-06C

VOLUME II B

SECTION D

ISSUE NO. 2, REV. 01 DATE 16.03.19

SHEET 45 OF 51

### Guidelines for Packing

- ✓ After inspection of control valves assembly. Smart Positioner along with Pressure Gauge shall be disassembled & packed separately.
- ✓ Threaded connection of Smart Positioner & Pressure Gauge shall be shipped with the end caps fitted to avoid any damage.
- ✓ Instructions with sketch for mounting the Smart Positioner & Pressure Gauge shall be sent along with the aforesaid accessories.
- ✓ Packing of the control valves and Smart Positioner along with Pressure Gauge shall be done in separate wooden boxes/cases in order to avoid damage during transit and also during storage at site in tropical climatic conditions for a period of 18-24 months.
- ✓ All valves & smart positioner along with pressure gauges shall be packed properly with quality wooden planks with proper wooden frame support. Moreover the valves are internally covered with polythene sheets to protect from the water and moisture entry.
- ✓ Stronger shock absorbing cover material like expanded Polyurethane which can take any direct impact on it shall be used for packing
- ✓ Proper reaper support to be provided in the packing and Valve assembly to be aligned properly to avoid the damage of accessories during transit due to vibration effect.
- ✓ Marking for Fragile & Condensing environment shall be done on the packing box.

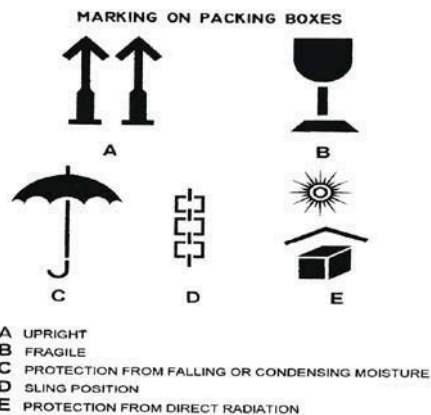

### The Following Details are to be marked on the Packing Cases

- ✓ Address of consignee
- ✓ Purchase order no.
- ✓ Description of items or title of packing list
- ✓ Weight
- ✓ Dimension of the Box
- ✓ Marking showing upright position
- ✓ Marking showing sling position
- ✓ Marking showing umbrella  
(i.e. for machines/components to be stored under covered storage)



## Sagardighi Thermal Power Project

1 x 660 MW Unit No. 5, Phase-III

Technical specification for  
**Control Valve with Accessories - Feed Control Valve**  
 (Pneumatically Operated)

SPEC NO.: PE-TS-445-145-I801A

DOCUMENT NO.

VOLUME II B

SECTION D

ISSUE NO.

REV. NO. 00

DATE: 23.01.2023

# SECTION-D

## SUB-VENDOR LIST



## Sagardighi Thermal Power Project

1 x 660 MW Unit No. 5, Phase-III

Technical specification for  
**Control Valve with Accessories - Feed Control Valve**  
(Pneumatically Operated)

SPEC NO.: PE-TS-445-145-I801A

DOCUMENT NO.

VOLUME II B

SECTION D

ISSUE NO.

REV. NO. 00

DATE: 23.01.2023

### SUB VENDOR LIST

(FOR ACCESSORIES)

SI. No.	ITEM DESCRIPTION	SUB-VENDORS
1.	SMART POSITIONER	ABB MASOLENIEN SIEMENS SAMR YOKOGAWA EMERSON (FISHER ROSEMOUNT) METSO YAMALKE MOORE
2.	AIR FILTER REGULATOR	FAIR CHILD, USA SHAVO NORGEN, MUMBAI SMC PNEUMATICS, NOIDA EMERSON(ASCO) CHENNAI FESTO, BANGALORE PLAKA, CHENNAI
3.	SOLENOID VALVE	ROTEX, VARODARA AVCON MUMBAI HERION, GERMANY IMI NORGEN, GERMANY JAFFERSON, ARGENTNA ASCO, CHENNAI/USA FESTO, BANGALORE SMC PNEUMATICS, NOIDA
4.	JUNCTION BOX	SUMIP COMPOSITES, AHMEDABAD KEMROK VARODARA AJMERA, MUMBAI TRINITY TOUCH, PALWAL

11	Air Filter Regulator	Parker Hannifin, Lebanon	Approved
	[Either from OEM/Authorised Source]	SHAVO NORGREN(INDIA)PVT LTD, BANGALORE	Approved
		JRU INSTRUMENTS (Formerly PLACKA)	Approved

13	SOLENOID VALVE	ASCO (I) LTD.	Approved
		ROTEX AUTOMATION LTD.	Approved
		NUCON INDUSTRIES PVT LTD	Approved
		IMI NORGREN HERION PVT. LTD.	Approved

77	Junction Box (Metal)	CHEMIN CONTROLS AND INSTRUMENTATION,PONDICHERRY	Approved
		ELECTRO MECHANICAL (INDIA),KOLKATA	Approved
		K.S.INSTRUMENTS PVT LTD,BANGALORE	Approved
		KHODAY CONTROL SYSTEMS PVT. LTD, BANGALORE	Approved
		MANISHA COMPOSITEK PVT. LTD.,PUNE	Approved
		PRAMMEN INDUSTRIES,PUDUKKOTTAI	Approved
		PYROTECH ELECTRONICS (P) LTD.,UDAIPUR	Approved

**ANNEXURE I**  
**1x660 MW SAGARDIGHI TPP Unit-5**  
**Control Valve (Low Load Feed Control Valve)**  
**GeM Bid No....., Dtd :**

**Letter head of Company**

Ref.....

Date.....

To,  
Bharat Heavy Electricals Limited  
PEM, PPEI Building, Plot No 25,  
Sector -16A, Noida (U.P)-201301

**Subject: - Certification regarding local content**

Dear Sir,

We hereby certify that items offered by us of **Control Valve (Low Load Feed Control Valve)** for **1x660 MW SAGARDIGHI TPP Unit-5** meets the requirement of minimum local content in line with clause no. ....of NIT and the Public Procurement (Preference to Make in India), Order 2017 dated-15.06.2017, 28.05.2018, 29.05.2019, 04.06.2020 & 16.09.2020. The Percentage (%) of Local content is .....%.

We further confirm that details of location at which the local value addition is made will be our registered works at .....(address of the works)

Yours very truly

..... (authorized signatory of company)

..... (firm name)

authorized signatory  
of company

# 1 X 660 MW WBPDCS SAGARDIGHI EXTN UNIT V

GeM BID NO. -....., Dt:-

## **ANNEXURE -II (INSTRUCTIONS TO PACKING LIST)**

For faster verification of bills, successful bidder to submit detailed Bill of Material (BOM) at the time of drawings/ documents submission after placement of PO. Each item of the BOM to be uniquely identified with item code no. or item Sl. No. Supplier to ensure that all items which will find separate mention in the packing list are covered in this detailed BOM.

Supplier to also give the following undertaking in the BOM:

“The BOM provided herewith completes the scope (in content and intent) of material supply under PO No. .... Dated ..... Any additional material which may become necessary for the intended application of the supplied items/package will be supplied free of cost in most reasonable time.

Packing List must indicate:

- a) Packing size
- b) Gross weight and net weight of each package
- c) Contents of the package with cross reference to BOM item code no. / Sl. No.
- d) Quantity of each items separately.

The packing list must cover all the BOM items.

Supplier to give following undertaking in the packing list:

The Packing list provided herewith is as per BOM approved under PO No. ----

**ANNEXURE III**

**1x660 MW SAGARDIGHI TPP Unit-5  
Control Valve (Low Load Feed Control Valve)  
GeM Bid No....., Dtd :**

**Letter head of Company**

Ref.....

Date.....

To,  
Bharat Heavy Electricals Limited  
PEM, PPEI Building, Plot No 25,  
Sector -16A, Noida (U.P)-201301

**Subject: - Certification regarding Land Border**

Dear Sir,

I have read the clause regarding restrictions of procurement from a bidder of a country which shares a land border with India. I hereby certify that M/s ..... (Organization name) is not from such a country and is eligible to be considered.

**Note :- Bidder is requested to furnish the above undertaking on company letterhead from the highest competent authority at your end (i.e Owner, partner, CMD, Director, company secretariat etc.).**

Yours very truly

..... (authorized signatory of company)

..... (firm name)

authorized signatory  
of company