



**BHARAT HEAVY ELECTRICALS LIMITED**  
**HEEP HARIDWAR INDIA-PIN 249403**  
**FAX NO: 0091 1334 226462**  
**PHONE NO: 01334 285462**



### REQUIREMENT OF TOOL BOX

The Heavy Electricals Equipment Plant (HEEP) located in Haridwar, India is one of the major manufacturing plants of Bharat Heavy Electricals Ltd. The core business of HEEP includes design and manufacture of large steam and gas turbines, turbo generators, Defense Items and so on.

Details of items details as below:

Sl. No.	MAT CODE	ITEM DISCREPTION	QUANTITY	UNIT	Delivery DAYS
1	W97017120183	DRG: 07829218849 REV:00 TOOL BOX-1 WITH PARTITIONS AS PER DRG. 07829218849	13	NUMBER	45 DAYS
2	W97017120191	DRG: 17829218830 REV:00 TOOL BOX-2 WITH PARTITIONS AS PER DRG. 17829218830	13	NUMBER	45 DAYS
3	W97017120205	DRG: 17829218804 REV:00 TOOL BOX-3 WITH PARTITIONS AS PER DRG. 17829218804	13	NUMBER	45 DAYS
4	W97017120213	DRG: 17829218831 REV:00 TOOL BOX-4 WITH PARTITIONS AS PER DRG. 17829218831	13	NUMBER	45 DAYS
5	W97017120230	DRG: 17829218864 REV:00 TOOL BOX-6 WITH PARTITIONS AS PER DRG. 17829218864	13	NUMBER	45 DAYS
6	W97017120248	DRG: 17829218822 REV:00 TOOL BOX-7 WITH PARTITIONS AS PER DRG. 17829218822	13	NUMBER	45 DAYS
7	W97017120221	DRG: 17829218816 REV:00 TOOL BOX-5 WITH PARTITIONS AS PER DRG. 17829218816	13	NUMBER	45 DAYS

1. ALL VENDORS TO PROVIDE POINT WISE REPLY/CONFIRMATION ALONG WITH RELEVANT SUPPORTING DOCUMENTS TO EACH AND EVERY POINT OF **PRE-QUALIFICATION REQUIREMENT/PQR** FOR ALL ENQUIRY ITEMS. NONCOMPLIANCE OF THESE MAY LEAD TO REJECTION OF OFFER AS THESE ARE ESSENTIAL CONDITION FOR PARTICIPATING IN TENDER ENQUIRY.
2. VENDOR TO SUBMIT DULY FILLED, SIGNED & STAMPED **COMMERICAL & QUALITY PARAMETER CHECKLIST** SHEET ALONG WITH SUPPORTING DOCUMENTS WITH OFFER.
3. VENDOR TO SUBMIT DULY FILLED, SIGNED & STAMPED **TECHNICAL PARAMETERS CHECK SHEET** ALONG WITH SUPPORTING DOCUMENTS WITH OFFER.
4. VENDOR TO SUBMIT PRODUCT CATALOGUE (IF ANY) OF OFFERED ITEM ALONG WITH OFFER.
5. EARLY DELIVERY IS ACCEPTABLE.
6. VENDOR TO SUBMIT MAKE IN INDIA CERTIFICATE AS PER ATTACHED FORMAT ONLY.
7. VENDOR TO CONFIRM TO PROVIDE TEST CERTIFICATES AS PER MANUFACTURER'S STANDARD PRACTICE INCLUDING DOCUMENTS CONFORMING TO ENQUIRY MODEL/PART NO. ALONG WITH THE MATERIAL.

8. VENDOR TO CONFIRM TO PROVIDE CERTIFICATE OF CONFORMANCE.
9. VENDOR TO CONFIRM TO PROVIDE IDENTIFICATION OF ALL ITEMS AND SAME SHOULD BE MENTIONED IN IDENTIFICATION REPORTS.

**QUALIFYING CONDITIONS for TOOL BOX**

<b>Sl. no.</b>	<b>PQR Requirement</b>	<b>Action</b>	<b>Bidder Response (Yes / No)</b>
1.	Who can manufacture or supply TOOL BOXES as per BHEL Drawings	Bidder to confirm	
2.	Bidder to submit experience of supply tool box. Documents like Unpriced PO copy/ Dispatch docs etc to be submitted.	Bidder to submit	
3.	Who has read and understood the BHEL Drawings.	Bidder to confirm	
4.	BHEL reserves the right to verify information submitted by Bidder. In case the information is found to be false/incorrect, the offer shall be rejected. Bidder to accept & confirm.	Bidder to confirm	
5.	Point numbers 1 to 4 are the Mandatory Qualification Requirements. Offers of Bidders not meeting these requirements will NOT be considered.	Bidder to confirm	

AGM/DPE







PROPRIETARY DATA OF DTD MELARA SPA  
 LIMITED RIGHTS OF A TECHNICAL DATA  
 THE TECHNICAL DATA CONTAINED HEREIN IS RESTRICTED AS TO USE, REPRODUCTION OR DISCLOSURE OF THE LICENSE AGREEMENT

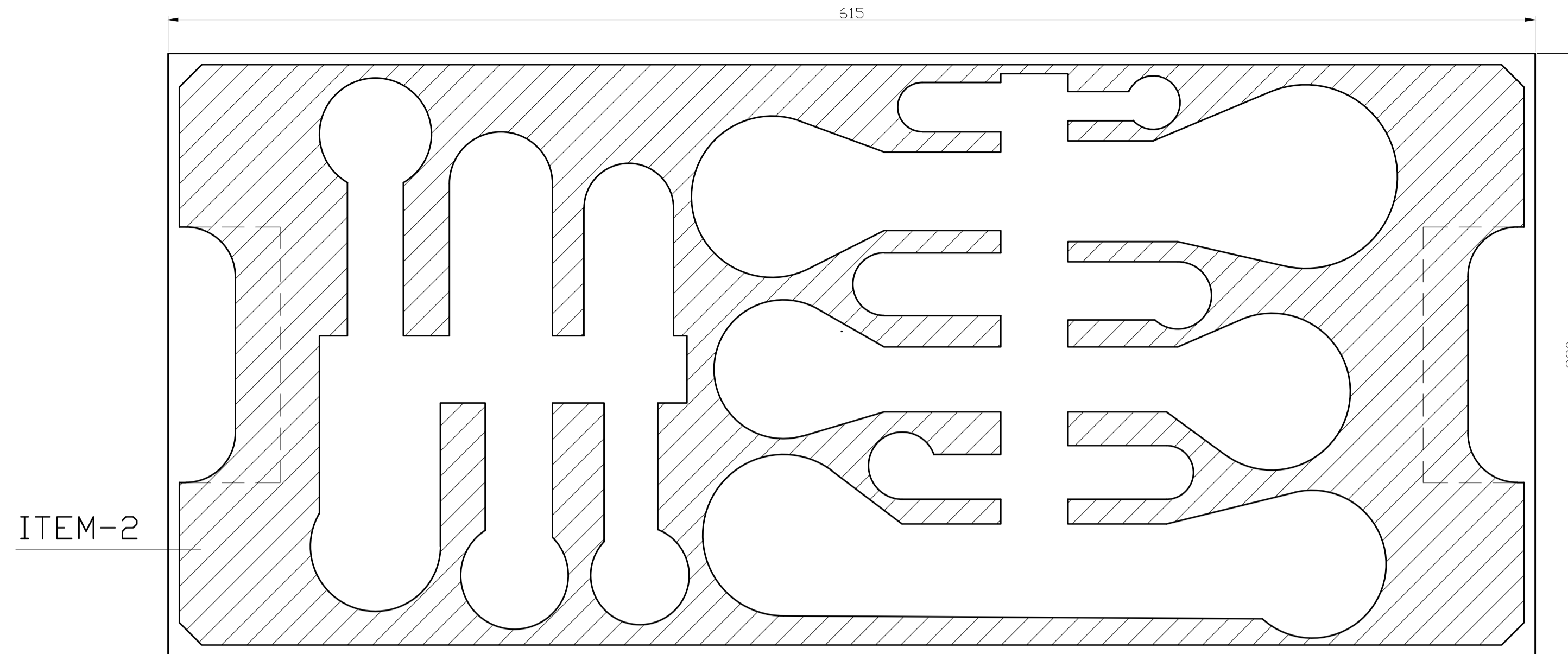

SECTION P-P

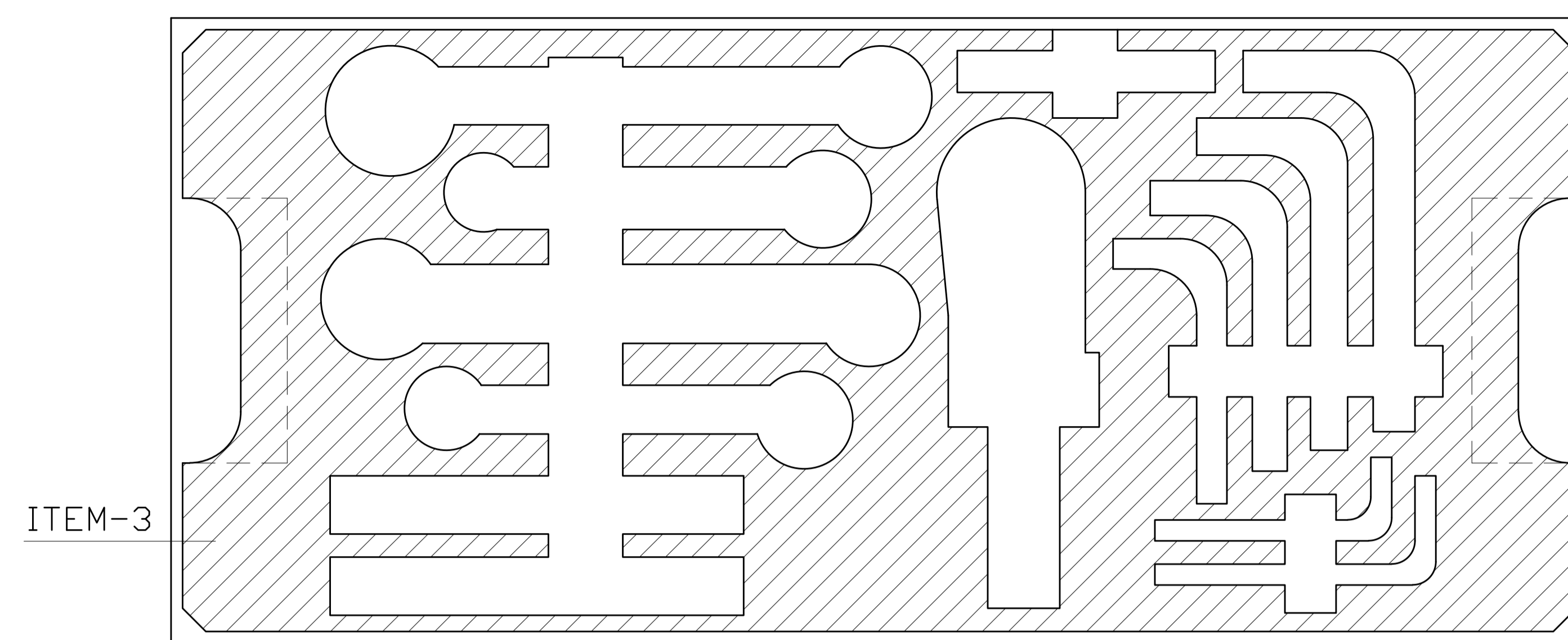

SECTION Q-Q

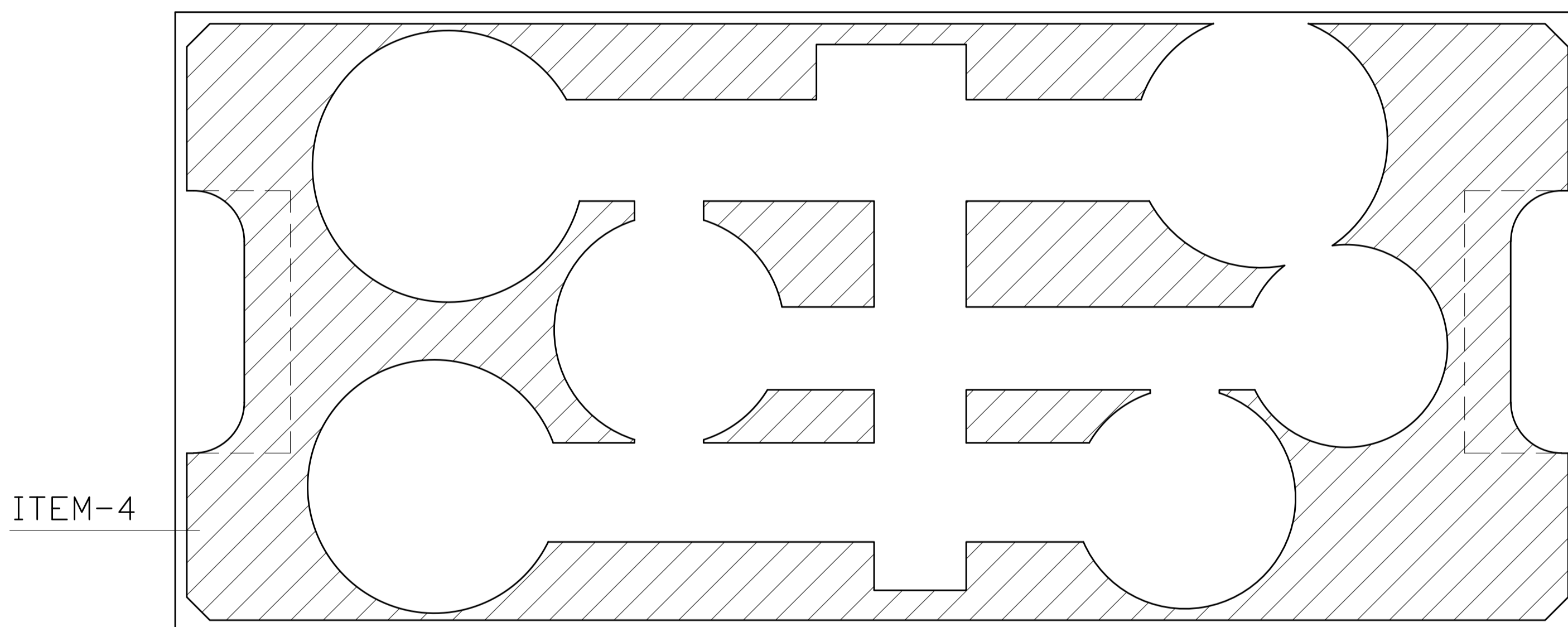

SECTION R-R

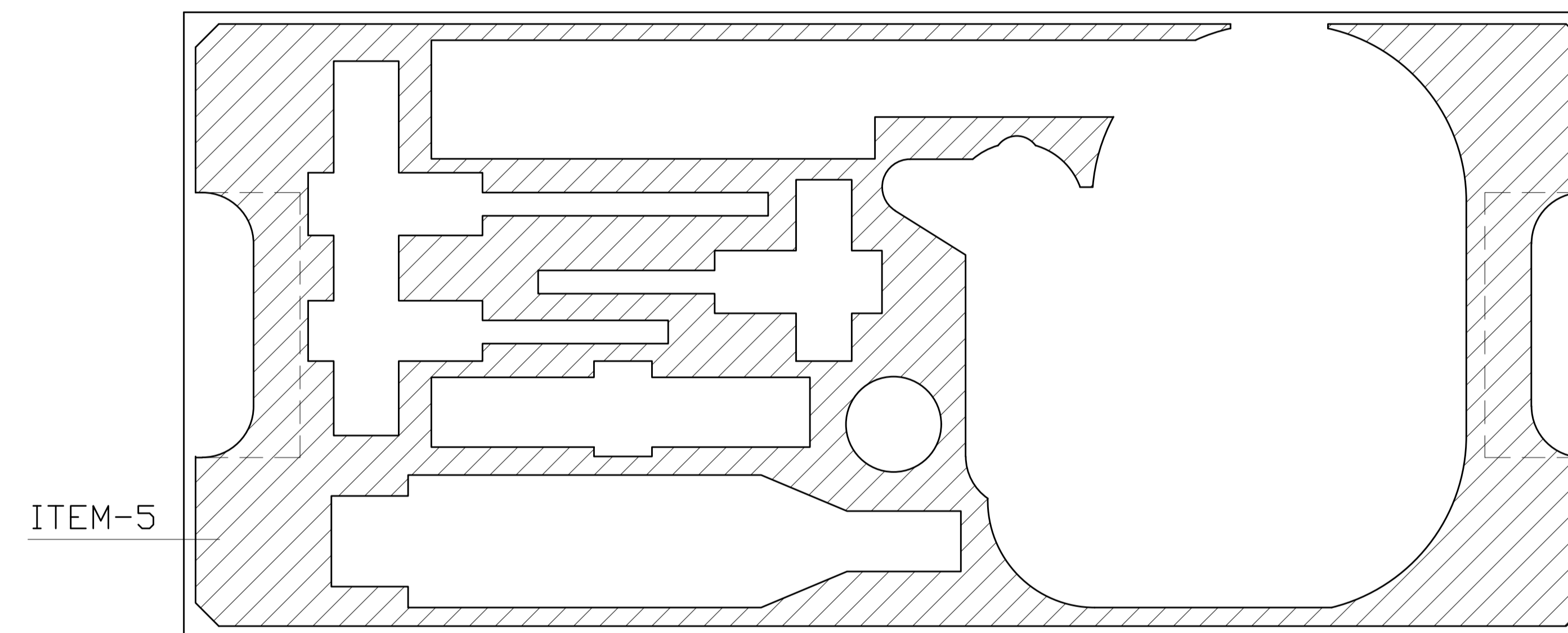

SECTION S-S

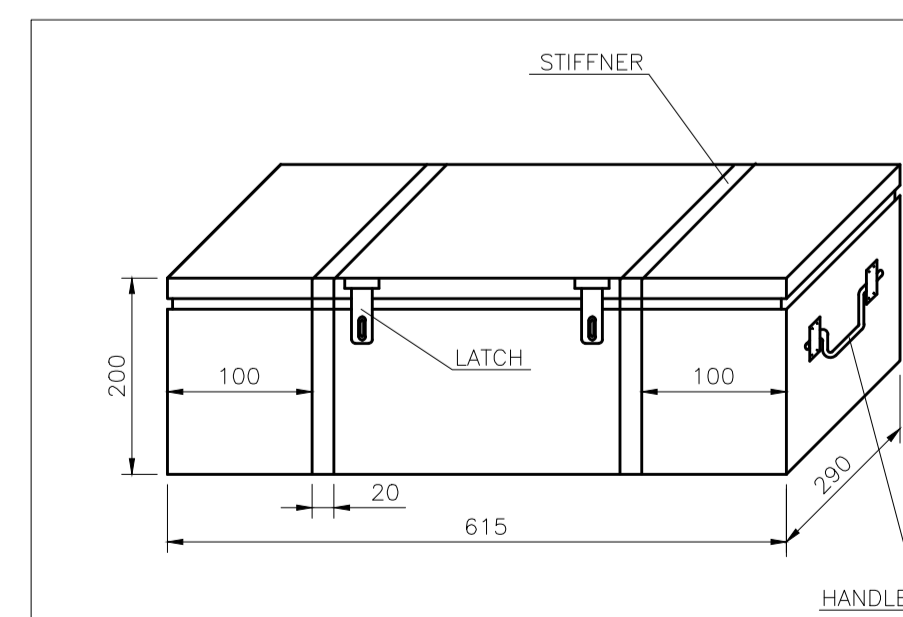
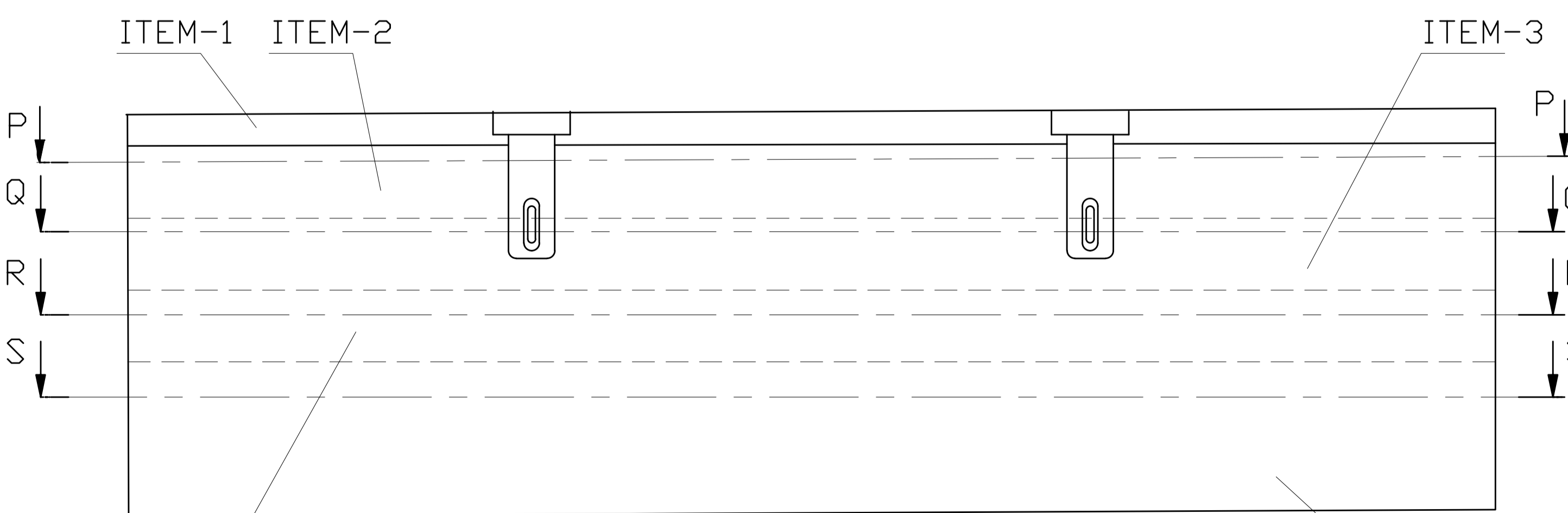

NOTES:

- COVER TO BE MADE FROM STEEL SHEET OF GAUGE 18 (~ 1.2 MM) AND BOX TO BE MADE FROM STEEL SHEET OF GAUGE 20 (~ 1.0 MM)
- ALL DIM. OF BOX ARE INTERNAL.
- TWO NOS STIFFNERS TO BE PROVIDED AROUND THE BOX AS SHOWN.
- HINGES ARE TO BE PROVIDED ON BACK SIDE TO OPEN THE COVER.
- FINAL PROTECTIVE FINISH - GREY PAINT, SHADE AS PER INDENTORS CHOICE.

TECHNICAL REQUIREMENTS

- IDENTIFICATION AS PER HW0400397

GENERAL TOLERANCES	DISTING TOLERANCES	FORGING TOLERANCES	WELDING TOLERANCES
LINEAR DIMENSIONS UP TO 18 (INCL) 0.15	0.10-0.15	0.10-0.15	0.10-0.15
> 18 TO 30 (INCL) 0.20	0.15-0.20	0.15-0.20	0.15-0.20
> 30 TO 60 (INCL) 0.30	0.20-0.30	0.20-0.30	0.20-0.30
> 60 TO 120 (INCL) 0.40	0.30-0.40	0.30-0.40	0.30-0.40
> 120 TO 180 (INCL) 0.50	0.40-0.50	0.40-0.50	0.40-0.50
> 180 TO 300 (INCL) 0.60	0.50-0.60	0.50-0.60	0.50-0.60
> 300 TO 600 (INCL) 0.80	0.60-0.80	0.60-0.80	0.60-0.80
> 600 TO 1200 (INCL) 1.00	0.80-1.00	0.80-1.00	0.80-1.00
> 1200 TO 1800 (INCL) 1.20	1.00-1.20	1.00-1.20	1.00-1.20
> 1800 TO 3000 (INCL) 1.50	1.20-1.50	1.20-1.50	1.20-1.50
> 3000 TO 6000 (INCL) 2.00	1.50-2.00	1.50-2.00	1.50-2.00
> 6000 TO 12000 (INCL) 2.50	2.00-2.50	2.00-2.50	2.00-2.50
> 12000 TO 18000 (INCL) 3.00	2.50-3.00	2.50-3.00	2.50-3.00
> 18000 TO 30000 (INCL) 4.00	3.00-4.00	3.00-4.00	3.00-4.00
> 30000 TO 60000 (INCL) 5.00	4.00-5.00	4.00-5.00	4.00-5.00
> 60000 TO 120000 (INCL) 6.00	5.00-6.00	5.00-6.00	5.00-6.00
> 120000 TO 180000 (INCL) 7.00	6.00-7.00	6.00-7.00	6.00-7.00
> 180000 TO 300000 (INCL) 8.00	7.00-8.00	7.00-8.00	7.00-8.00
> 300000 TO 600000 (INCL) 10.00	8.00-10.00	8.00-10.00	8.00-10.00
> 600000 TO 1200000 (INCL) 12.00	10.00-12.00	10.00-12.00	10.00-12.00
> 1200000 TO 1800000 (INCL) 15.00	12.00-15.00	12.00-15.00	12.00-15.00
> 1800000 TO 3000000 (INCL) 20.00	15.00-20.00	15.00-20.00	15.00-20.00
> 3000000 TO 6000000 (INCL) 25.00	20.00-25.00	20.00-25.00	20.00-25.00
> 6000000 TO 12000000 (INCL) 30.00	25.00-30.00	25.00-30.00	25.00-30.00
> 12000000 TO 18000000 (INCL) 40.00	30.00-40.00	30.00-40.00	30.00-40.00
> 18000000 TO 30000000 (INCL) 50.00	40.00-50.00	40.00-50.00	40.00-50.00
> 30000000 TO 60000000 (INCL) 60.00	50.00-60.00	50.00-60.00	50.00-60.00
> 60000000 TO 120000000 (INCL) 80.00	60.00-80.00	60.00-80.00	60.00-80.00
> 120000000 TO 180000000 (INCL) 100.00	80.00-100.00	80.00-100.00	80.00-100.00
> 180000000 TO 300000000 (INCL) 120.00	100.00-120.00	100.00-120.00	100.00-120.00
> 300000000 TO 600000000 (INCL) 150.00	120.00-150.00	120.00-150.00	120.00-150.00
> 600000000 TO 1200000000 (INCL) 200.00	150.00-200.00	150.00-200.00	150.00-200.00
> 1200000000 TO 1800000000 (INCL) 250.00	200.00-250.00	200.00-250.00	200.00-250.00
> 1800000000 TO 3000000000 (INCL) 300.00	250.00-300.00	250.00-300.00	250.00-300.00
> 3000000000 TO 6000000000 (INCL) 400.00	300.00-400.00	300.00-400.00	300.00-400.00
> 6000000000 TO 12000000000 (INCL) 500.00	400.00-500.00	400.00-500.00	400.00-500.00
> 12000000000 TO 18000000000 (INCL) 600.00	500.00-600.00	500.00-600.00	500.00-600.00
> 18000000000 TO 30000000000 (INCL) 800.00	600.00-800.00	600.00-800.00	600.00-800.00
> 30000000000 TO 60000000000 (INCL) 1000.00	800.00-1000.00	800.00-1000.00	800.00-1000.00
> 60000000000 TO 120000000000 (INCL) 1200.00	1000.00-1200.00	1000.00-1200.00	1000.00-1200.00
> 120000000000 TO 180000000000 (INCL) 1500.00	1200.00-1500.00	1200.00-1500.00	1200.00-1500.00
> 180000000000 TO 300000000000 (INCL) 2000.00	1500.00-2000.00	1500.00-2000.00	1500.00-2000.00
> 300000000000 TO 600000000000 (INCL) 2500.00	2000.00-2500.00	2000.00-2500.00	2000.00-2500.00
> 600000000000 TO 1200000000000 (INCL) 3000.00	2500.00-3000.00	2500.00-3000.00	2500.00-3000.00
> 1200000000000 TO 1800000000000 (INCL) 4000.00	3000.00-4000.00	3000.00-4000.00	3000.00-4000.00
> 1800000000000 TO 3000000000000 (INCL) 5000.00	4000.00-5000.00	4000.00-5000.00	4000.00-5000.00
> 3000000000000 TO 6000000000000 (INCL) 6000.00	5000.00-6000.00	5000.00-6000.00	5000.00-6000.00
> 6000000000000 TO 12000000000000 (INCL) 8000.00	6000.00-8000.00	6000.00-8000.00	6000.00-8000.00
> 12000000000000 TO 18000000000000 (INCL) 10000.00	8000.00-10000.00	8000.00-10000.00	8000.00-10000.00
> 18000000000000 TO 30000000000000 (INCL) 12000.00	10000.00-12000.00	10000.00-12000.00	10000.00-12000.00
> 30000000000000 TO 60000000000000 (INCL) 15000.00	12000.00-15000.00	12000.00-15000.00	12000.00-15000.00
> 60000000000000 TO 120000000000000 (INCL) 20000.00	15000.00-20000.00	15000.00-20000.00	15000.00-20000.00
> 120000000000000 TO 180000000000000 (INCL) 25000.00	20000.00-25000.00	20000.00-25000.00	20000.00-25000.00
> 180000000000000 TO 300000000000000 (INCL) 30000.00	25000.00-30000.00	25000.00-30000.00	25000.00-30000.00
> 300000000000000 TO 600000000000000 (INCL) 40000.00	30000.00-40000.00	30000.00-40000.00	30000.00-40000.00
> 600000000000000 TO 1200000000000000 (INCL) 50000.00	40000.00-50000.00	40000.00-50000.00	40000.00-50000.00
> 1200000000000000 TO 1800000000000000 (INCL) 60000.00	50000.00-60000.00	50000.00-60000.00	50000.00-60000.00
> 1800000000000000 TO 3000000000000000 (INCL) 80000.00	60000.00-80000.00	60000.00-80000.00	60000.00-80000.00
> 3000000000000000 TO 6000000000000000 (INCL) 100000.00	80000.00-100000.00	80000.00-100000.00	80000.00-100000.00
> 6000000000000000 TO 12000000000000000 (INCL) 120000.00	100000.00-120000.00	100000.00-120000.00	100000.00-120000.00
> 12000000000000000 TO 18000000000000000 (INCL) 150000.00	120000.00-150000.00	120000.00-150000.00	120000.00-150000.00
> 18000000000000000 TO 30000000000000000 (INCL) 200000.00	150000.00-200000.00	150000.00-200000.00	150000.00-200000.00
> 30000000000000000 TO 60000000000000000 (INCL) 250000.00	200000.00-250000.00	200000.00-250000.00	200000.00-250000.00
> 60000000000000000 TO 120000000000000000 (INCL) 300000.00	250000.00-300000.00	250000.00-300000.00	250000.00-300000.00
> 120000000000000000 TO 180000000000000000 (INCL) 400000.00	300000.00-400000.00	300000.00-400000.00	300000.00-400000.00
> 180000000000000000 TO 300000000000000000 (INCL) 500000.00	400000.00-500000.00	400000.00-500000.00	400000.00-500000.00
> 300000000000000000 TO 600000000000000000 (INCL) 600000.00	500000.00-600000.00	500000.00-600000.00	500000.00-600000.00
> 600000000000000000 TO 1200000000000000000 (INCL) 800000.00	600000.00-800000.00	600000.00-800000.00	600000.00-800000.00
> 1200000000000000000 TO 1800000000000000000 (INCL) 1000000.00	800000.00-1000000.00	800000.00-1000000.00	800000.00-1000000.00
> 1800000000000000000 TO 3000000000000000000 (INCL) 1200000.00	1000000.00-1200000.00	1000000.00-1200000.00	1000000.00-1200000.00
> 3000000000000000000 TO 6000000000000000000 (INCL) 1500000.00	1200000.00-1500000.00	1200000.00-1500000.00	1200000.00-1500000.00
> 6000000000000000000 TO 12000000000000000000 (INCL) 2000000.00	1500000.00-2000000.00	1500000.00-2000000.00	1500000.00-2000000.00
> 12000000000000000000 TO 18000000000000000000 (INCL) 2500000.00	2000000.00-2500000.00	2000000.00-2500000.00	2000000.00-2500000.00
> 18000000000000000000 TO 30000000000000000000 (INCL) 3000000.00	2500000.00-3000000.00	2500000.00-3000000.00	2500000.00-3000000.00
> 30000000000000000000 TO 60000000000000000000 (INCL) 4000000.00	3000000.00-4000000.00	3000000.00-4000000.00	3000000.00-4000000.00
> 60000000000000000000 TO 120000000000000000000 (INCL) 5000000.00	4000000.00-5000000.00	4000000.00-5000000.00	4000000.00-5000000.00
> 120000000000000000000 TO 180000000000000000000 (INCL) 6000000.00	5000000.00-6000000.00	5000000.00-6000000.00	5000000.00-6000000.00
> 180000000000000000000 TO 300000000000000000000 (INCL) 8000000.00	6000000.00-8000000.00	6000000.00-8000000.00	6000000.00-8000000.00
> 300000000000000000000 TO 600000000000000000000 (INCL) 10000000.00	8000000.00-10000000.00	8000000.00-10000000.00	8000000.00-10000000.00
> 600000000000000000000 TO 1200000000000000000000 (INCL) 12000000.00	10000000.00-12000000.00	10000000.00-12000000.00	10000000.00-12000000.00
> 1200000000000000000000 TO 1800000000000000000000 (INCL) 15000000.00	12000000.00-15000000.00	12000000.00-15000000.00	12000000.00-15000000.00
> 1800000000000000000000 TO 3000000000000000000000 (INCL) 20000000.00	15000000.00-20000000.00	15000000.00-20000000.00	15000000.00-20000000.00
> 3000000000000000000000 TO 6000000000000000000000 (INCL) 25000000.00	20000000.00-25000000.00	20000000.00-25000000.00	20000000.00-25000000.00
> 6000000000000000000000 TO 12000000000000000000000 (INCL) 30000000.00	25000000.00-30000000.00	25000000.00-30000000.00	25000000.00-30000000.00
> 12000000000000000000000 TO 18000000000000000000000 (INCL) 40000000.00	30000000.00-40000000.00	30000000.00-40000000.00	30000000.00-40000000.00
> 18000000000000000000000 TO 30000000000000000000000 (INCL) 50000000.00	40000000.00-50000000.00	40000000.00-50000000.00	40000000.00-50000000.00
> 30000000000000000000000 TO 60000000000000000000000 (INCL) 60000000.00	50000000.00-60000000.00	50000000.00-60000000.00	50000000.00-60000000.00
> 60000000000000000000000 TO 120000000000000000000000 (INCL) 80000000.00	60000000.00-80000000.00	60000000.00-80000000.00	60000000.00-80000000.00
> 120000000000000000000000 TO 180000000000000000000000 (INCL) 100000000.00	80000000.00-100000000.00	80000000.00-100000000.00	80000000.00-100000000.00
> 180000000000000000000000 TO 300000000000000000000000 (INCL) 120000000.00	100000000.00-120000000.00	100000000.00-120000000.00	100000000.00-120000000.00
> 300000000000000000000000 TO 600000000000000000000000 (INCL) 150000000.00	120000000.00-150000000.00	120000000.00-150000000.00	120000000.00-150000000.00



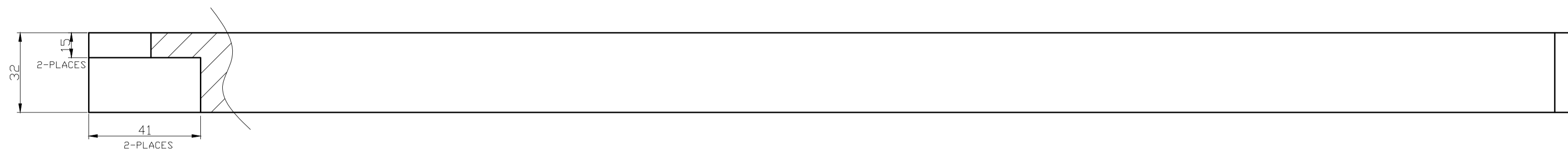

SEC. A-A

ALL SLOTS ARE 22 MM DEEP.

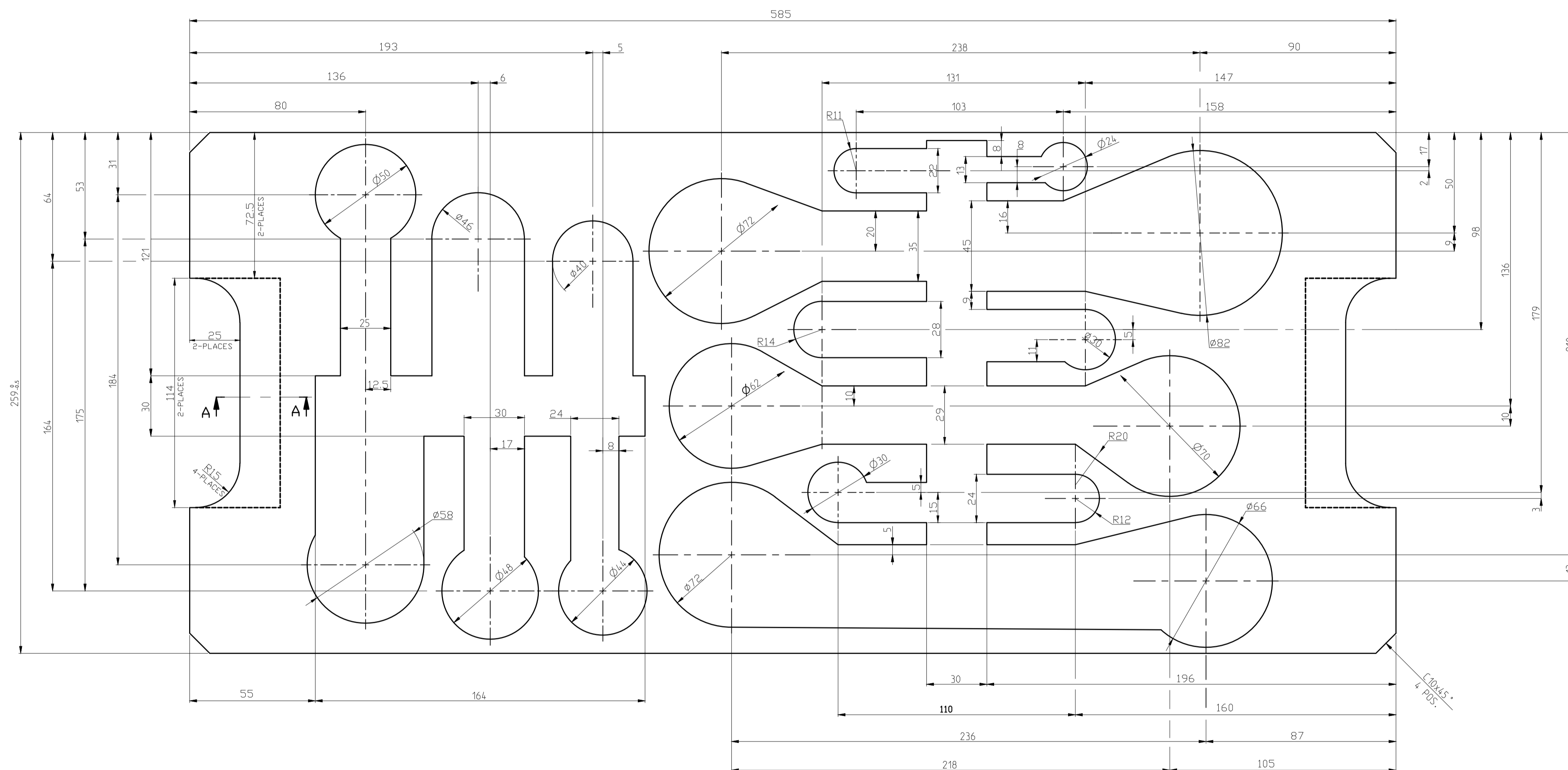

**TECHNICAL REQUIREMENTS**

1. MATERIAL- SHEESHAM WOOD WITH BASE PLATE OF PLYWOOD (THK-10MM).
2. TREATMENT- LACQUERING ALL OVER.
3. ALL INNER DIMENSIONS OF LAYOUT ARE FOR REFERENCE ONLY AND MAY BE CHANGED DEPENDING ON TOOL PLACEMENT AND SUPPLIER HAS TO MODIFY SUITABLY AT BHEL HARIDWAR-WORKS.

**ITEM-2**

GENERAL TOLERANCES LINEAR DIMENSIONS UP TO 18 <math>\pm 0.10</math> > 18 TO 30 <math>\pm 0.15</math> ANGLES <math>\pm 30'</math>	CASTING TOLERANCES LINEAR DIMENSIONS <math>\pm 0.15</math> (1.5mm THICKNESS) <math>\pm 0.20</math> (3.0mm) ANGLES <math>\pm 30'</math>	FORGING TOLERANCES LINEAR DIMENSIONS UP TO 18 <math>\pm 0.15</math> > 18 TO 30 <math>\pm 0.20</math> ANGLES <math>\pm 30'</math>	UNLESS OTHERWISE SPECIFIED ROUND EDGES 0.5 AND CHAMFER 0.5x45° SURFACE FINISH: -
---	--	---	--

REV/GR. SP. NO. 07829062017-00	STATUS DRG	TYPE OF PRODUCT DR	SRGM 76/62
DESIGNER DABG-T	CHECKED SUMIT	DATE 5.12.24	NAME OF CUSTOMER/ PROJECT
REV. DATE	ALTERED CHECKED	SECT. DPE	SCALE NTS
CODE 4260	WEIGHT(KG) -	REF. TO ASSY DRG. 07829218011	ITEM NO. 1
TITLE TOOL BOX-2 WITH PARTITIONS	CARD CODE -	DRAWING NO. 17829218830	REV. -
		SHEET NO. 03	TOTAL SHEETS 05

PROPRIETARY DATA OF DTD MELARA SPA  
 LIMITED RIGHTS OF TECHNICAL DATA  
 THE TECHNICAL DATA CONTAINED HEREIN IS RESTRICTED AS TO USE, REPRODUCTION OR DISCLOSURE AS PER TERMS AND CONDITIONS OF THE LICENSE AGREEMENT

INVENTORY NO. SIGN & DATE REF. DRG. NO.  
 17829218830

PROPRIETARY DATA OF DTD MELARA SPA. LIMITED RIGHTS OF TECHNICAL DATA. THE TECHNICAL DATA CONTAINED HEREIN IS RESTRICTED AND TO BE USED ONLY FOR THE PURPOSES AND CONDITIONS OF THE LICENSE AGREEMENT.

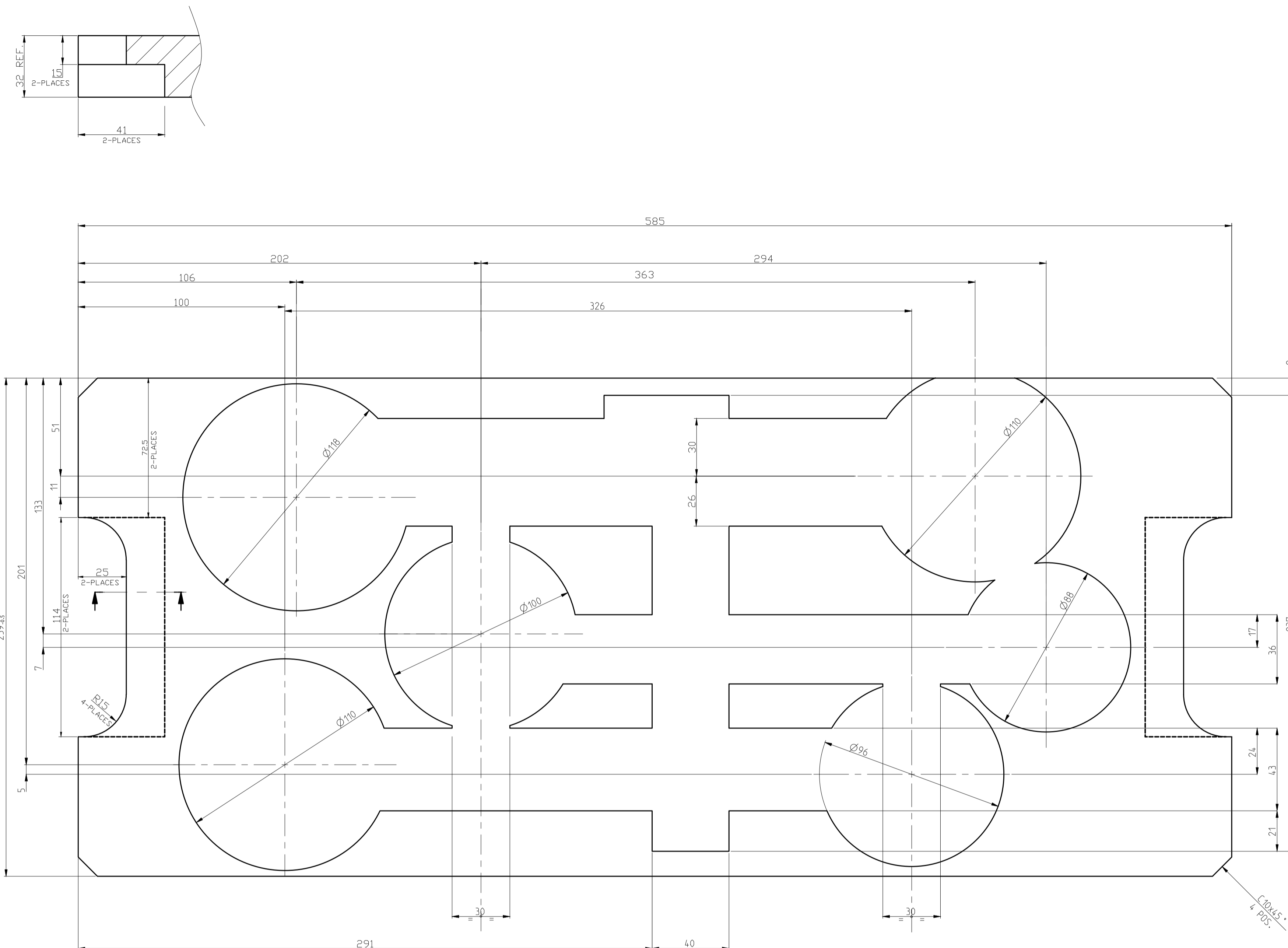

ALL SLOTS ARE 22 MM DEEP.

### ITEM-4

#### TECHNICAL REQUIREMENTS

1. MATERIAL- SHEESHAM WOOD WITH BASE PLATE OF PLYWOOD (THK-10MM).
2. TREATMENT- LACQUERING ALL OVER.
3. ALL INNER DIMENSIONS OF LAYOUT ARE FOR REFERENCE ONLY AND MAY BE CHANGED DEPENDING ON TOOL PLACEMENT AND SUPPLIER HAS TO MODIFY SUITABLY AT BHEL HARIDWAR-WORKS.

GENERAL TOLERANCES LINEAR DIMENSIONS UP TO 18 <math>±0.10</math> > 18 TO 80 <math>±0.25</math> ANGLES <math>±0.7</math>		CASTING TOLERANCES LINEAR DIMENSIONS <math>±0.15</math> (MAX THICKNESS <math>±0.3</math> UNL. <math>±0.5</math> IN) ANGLES <math>±2</math>		FORGING TOLERANCES LINEAR DIMENSIONS UP TO 18 <math>±0.15</math> > 18 TO 80 <math>±0.4</math> ANGLES <math>±1</math>		UNLESS OTHERWISE SPECIFIED ROUND EDGES <math>R3</math> AND CHAMFER <math>C0.4</math> SURFACE FINISH <math>Ra</math> REQUIRE STOCK MATERIAL TO BE FINISHED AT WORKSHOP	
REV/GR. SP. NO. 07829062017-00		STATUS OF Dwg. 3d/-		DATE 5.12.24		TYPE OF PRODUCT DR	
DESIGNER NAME T.SIGN. DATE		NAME OF CUSTOMER/ PROJECT		SRGM 76/62		NAME SIGN DATE NO. OF SHEETS	
DABG-T SUMIT		BHARAT HEAVY ELECTRICALS LTD. RANIPUR - HARDWAR		SANDHEEP SG/- 16.12.24		CHD HARSHWORA SG/- 16.12.24	
REV. DATE ALTERED CHECKED		SECT. DPE		SCALE NTS		WEIGHT(KG) -	
CODE 4260		REF. TO ASSY. DRG. 07829218011		ITEM NO. 1		NO. OF SHEETS 1	
TITLE TOOL BOX-2 WITH PARTITIONS		CARD CODE 17829218830		DRAWING NO. 17829218830		REV. -	
SHEET NO. 04		INDDF SHEETS 05					



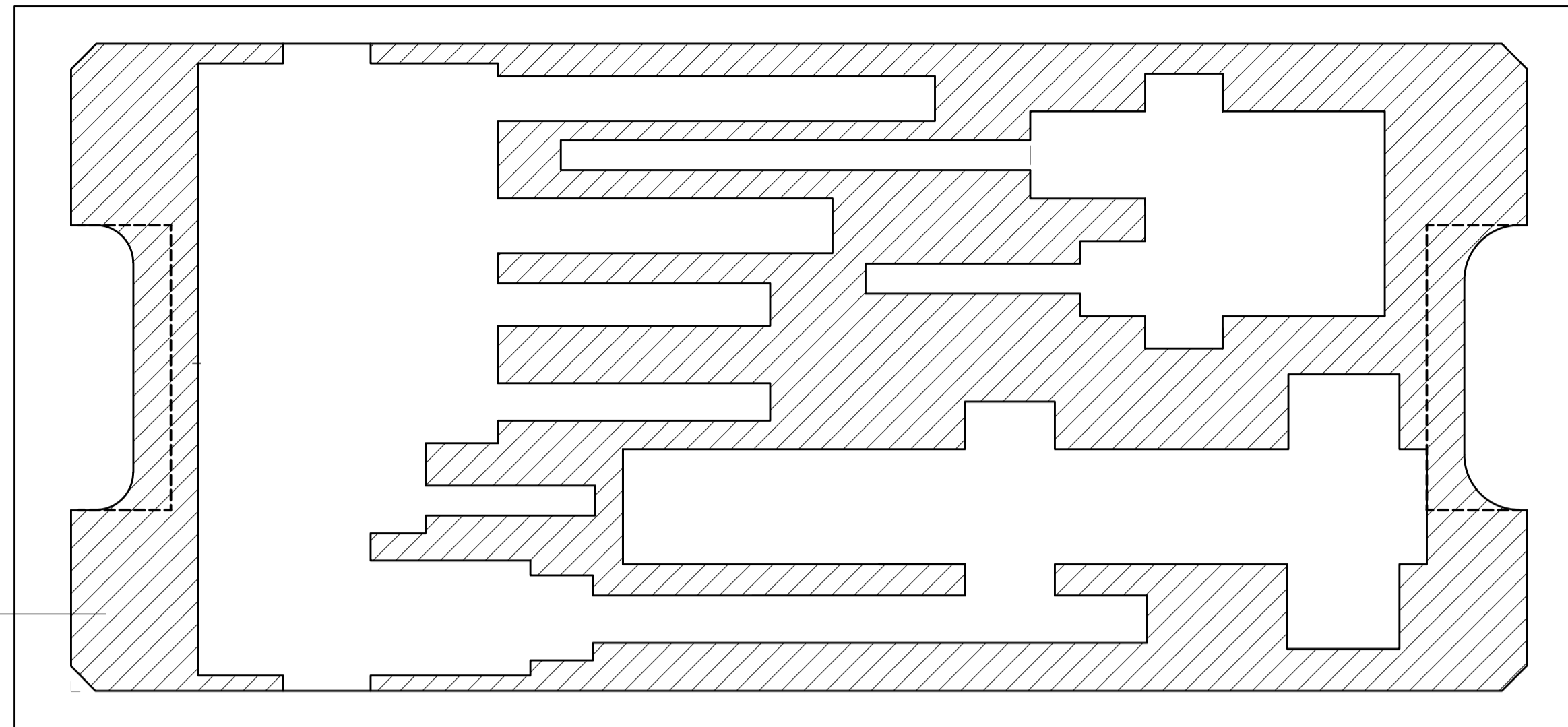

ITEM-4

SECTION P-P

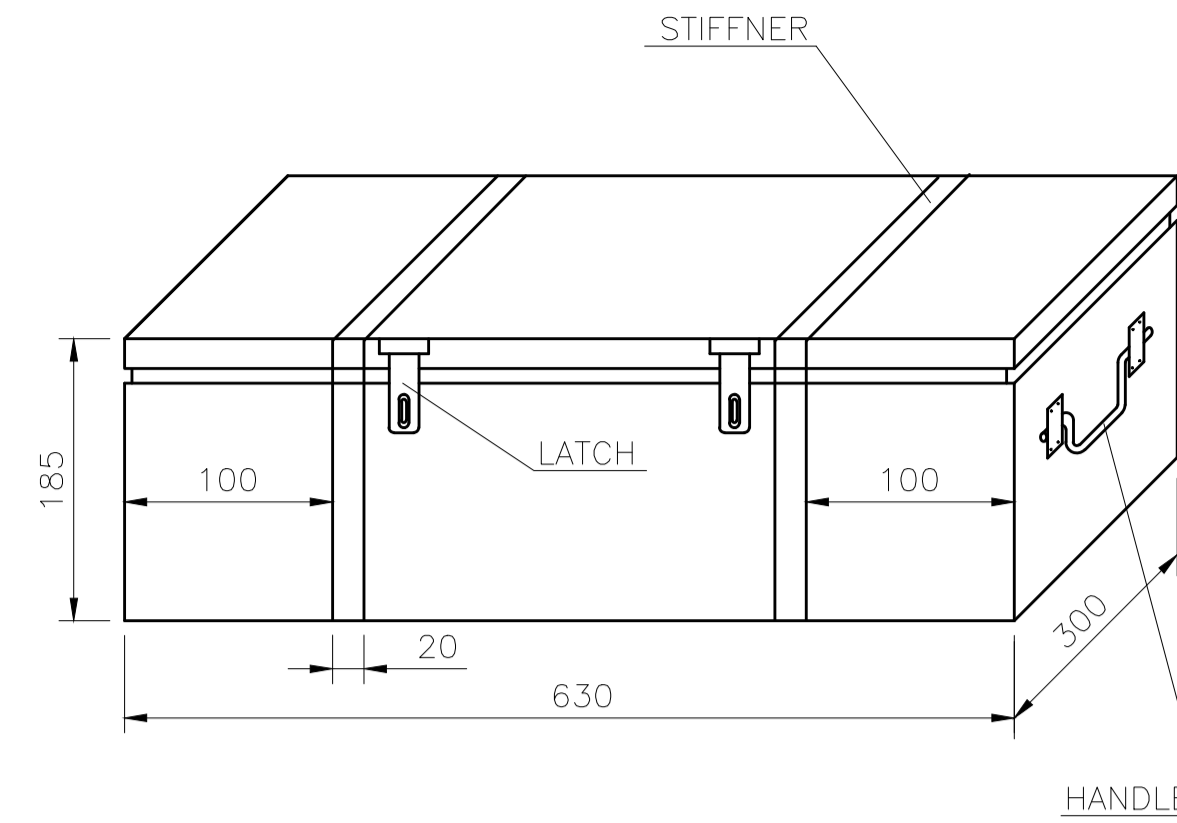

ITEM-1  
CASE

NOTES:

- COVER TO BE MADE FROM STEEL SHEET OF GAUGE 18 (~ 1.2 MM) AND BOX TO BE MADE FROM STEEL SHEET OF GAUGE 20 (~ 1.0 MM)
- ALL DIM. OF BOX ARE INTERNAL.
- TWO NOS STIFFNERS TO BE PROVIDED AROUND THE BOX AS SHOWN.
- HINGES ARE TO BE PROVIDED ON BACK SIDE TO OPEN THE COVER.
- FINAL PROTECTIVE FINISH - GREY PAINT, SHADE AS PER INDENTORS CHOICE.

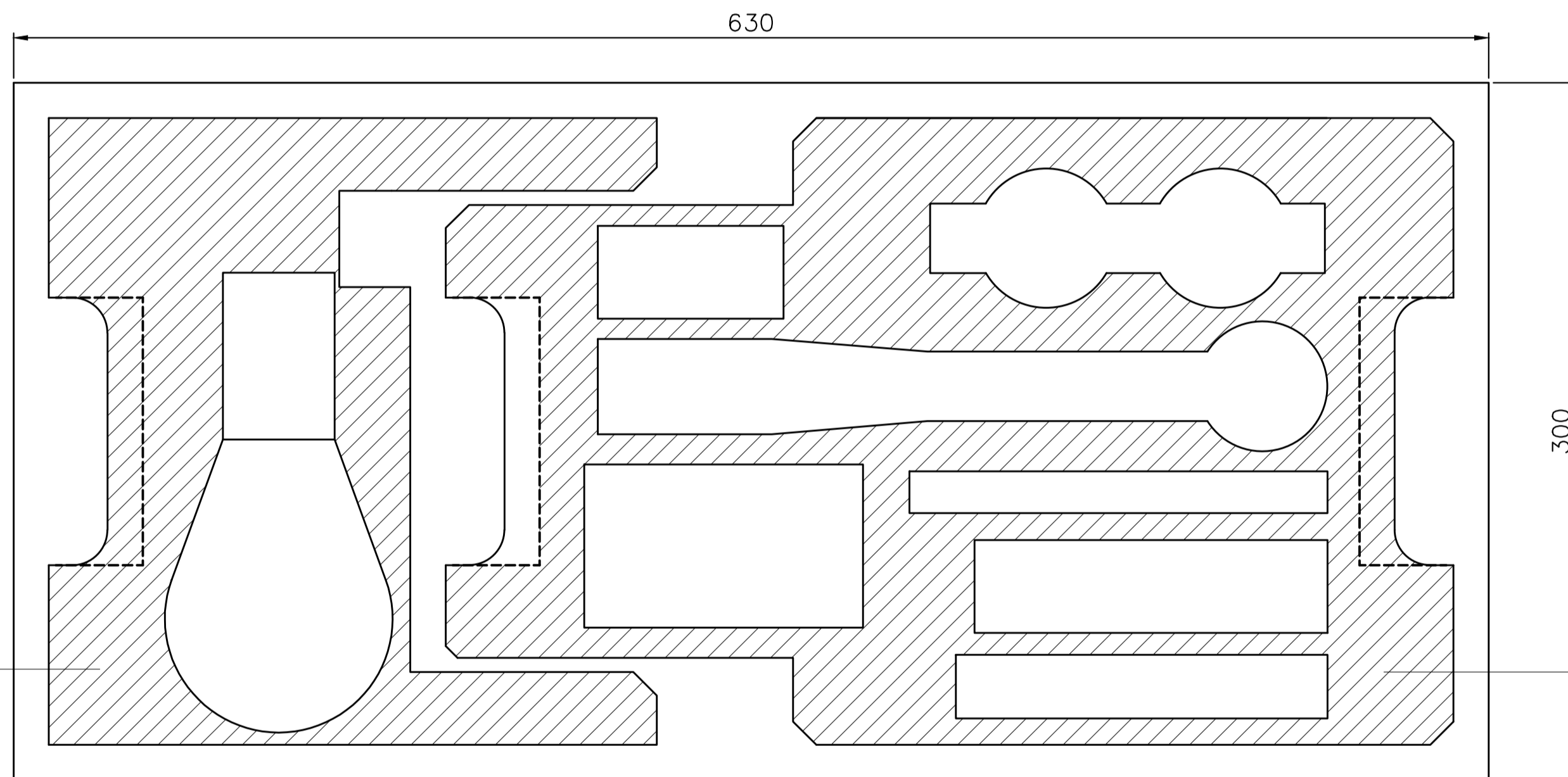

ITEM-3

ITEM-2

SECTION Q-Q

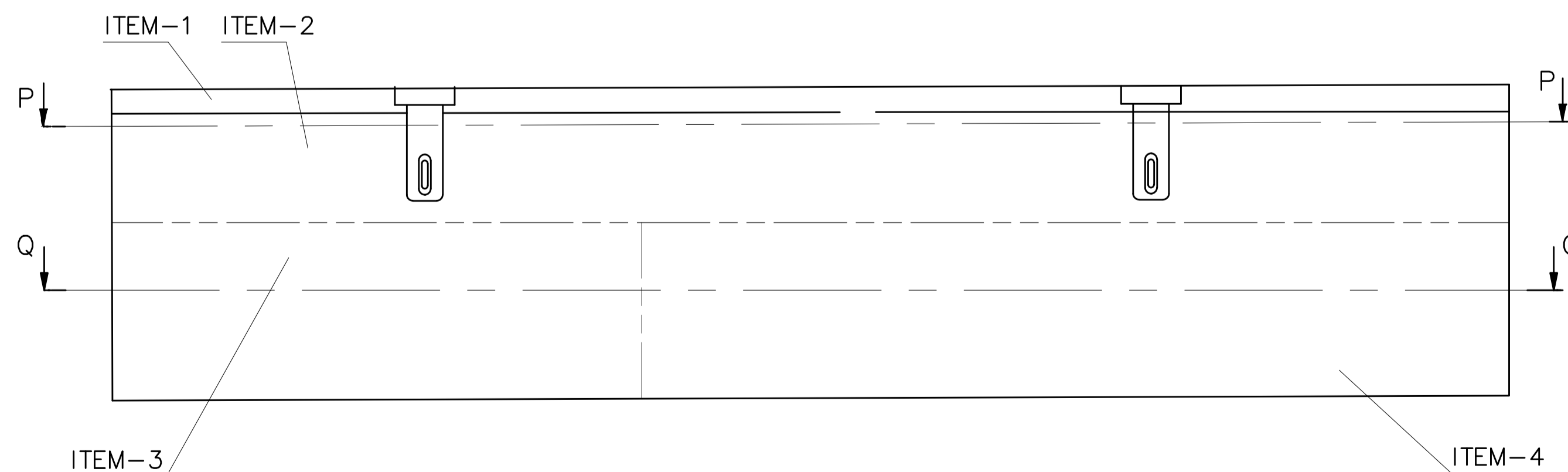

ITEM-3

ITEM-4

TECHNICAL REQUIREMENTS

- IDENTIFICATION AS PER HW0400397

GENERAL TOLERANCES LINEAR DIMENSIONS UP TO 18 ±0.15 > 18 TO 80 ±0.25 > 80 ±0.4 ANGLES ±30'	CASTING TOLERANCES LINEAR DIMENSIONS ±(0.5%+1MM) THICKNESS ±0.5 (MIN. ±0.5mm) ANGLES ±2'	FORGING TOLERANCES LINEAR DIMENSIONS UP TO 18 ±0.5-0.3 > 18 TO 80 ±1 -0.5 > 80 ±2 -0.8 ANGLES ±1'	UNLESS OTHERWISE SPECIFIED ROUND EDGES 0.3 AND CHAMFER 0.3x45° SURFACE MARKED --- REQUIRE STOCK MATERIAL TO BE REMOVED AT ASSEMBLY
--	---	---	--

CBOM	07829062017-00	STATUS OF DRG	
AGREED	NAME	SIGN	DATE
DABG-T	SUMIT	Sd/-	5.12.24

TYPE OF PRODUCT		SRGM 76/62	
OR			
NAME OF CUSTOMER/PROJECT			

GRADE OF UNTOL.DIM	
M/CG.-C/M/F	AA0230208
WELDING-#/B/C/D	AA0621104
GAS CUTTING	T3'AA0621104

NAME	SIGN	DATE	NO. OF VAR
DRN SANDEEP	Sd/-	16.12.2024	
CHD HARENDRA	Sd/-	16.12.2024	
APPD SK SINGH	Sd/-	16.12.2024	

REV	DATE	ALTERED CHECKED

REV	DATE	ALTERED CHECKED

DEPT DPE	SCALE	WEIGHT (KG)	REF. TO ASSY. DRG.	ITEM No.	NO. OF ITEMS
CODE 4260	NTS	-	17829218012	1	---

TITLE : TOOL BOX-3 WITH PARTITIONS	CARD CODE	DRAWING NO. 17829218804
		SHEET No. -01 No. OF SHEETS -04

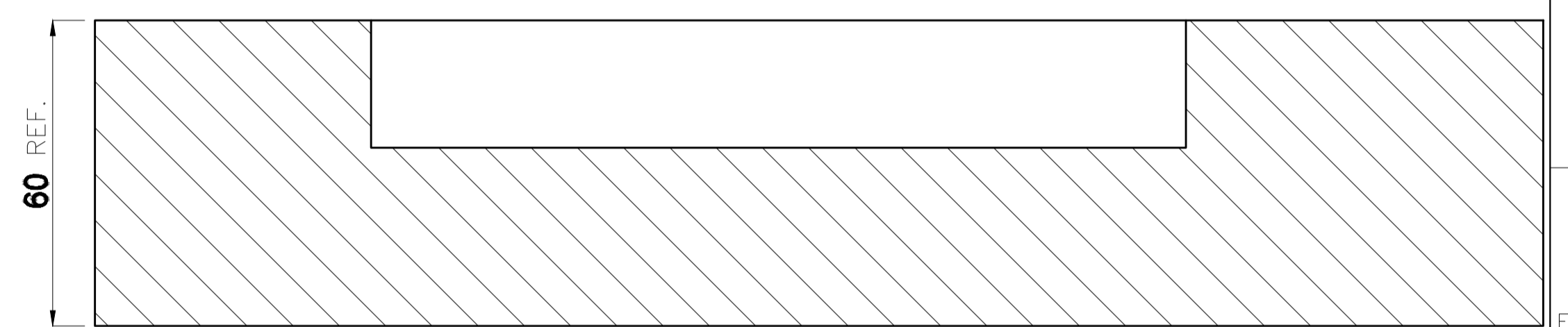
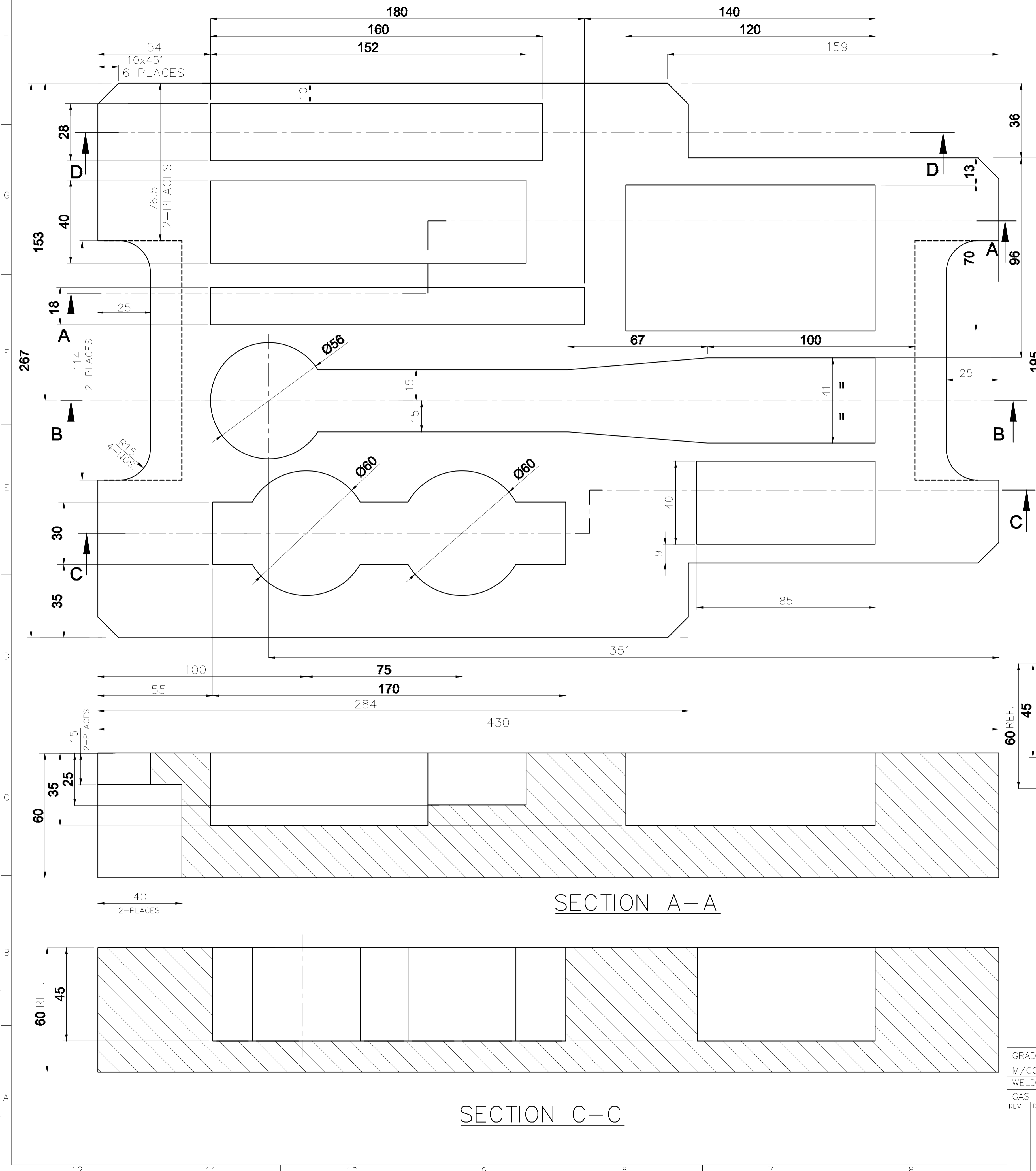

SECTION D-D

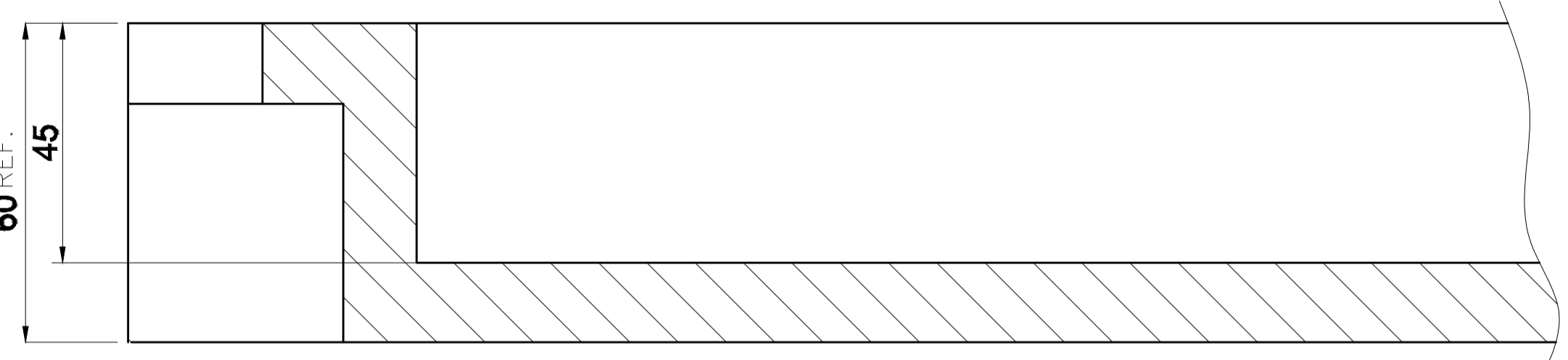

SECTION B-B

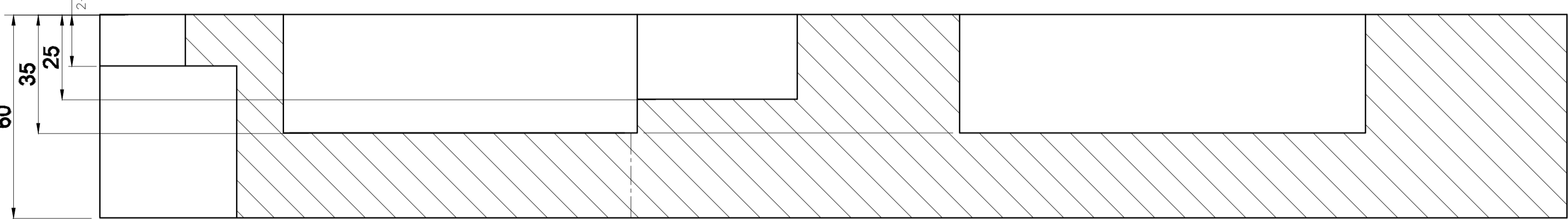

SECTION A-A

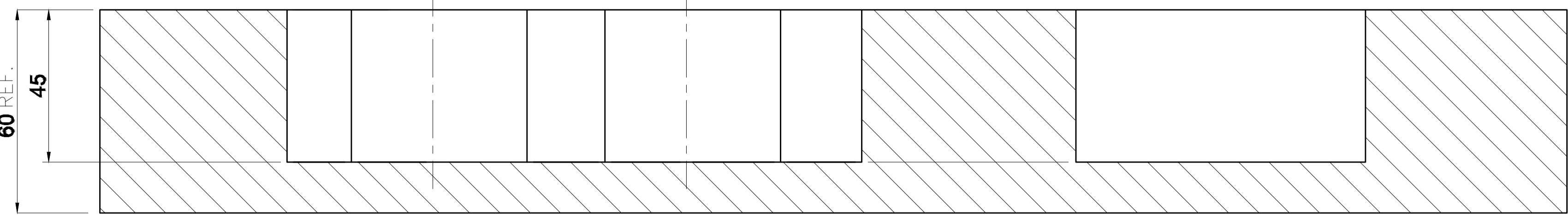

SECTION C-C

TECHNICAL REQUIREMENTS

1. MATERIAL- SHEESHAM WOOD WITH BASE PLATE OF PLYWOOD (THK-10MM).
2. TREATMENT- LACQUERING ALL OVER.
3. ALL INNER DIMENSIONS OF LAYOUT ARE FOR REFERENCE ONLY AND MAY BE CHANGED DEPENDING ON TOOL PLACEMENT AND SUPPLIER HAS TO MODIFY SUITABLY AT BHEL HARIDWAR-WORKS.

GENERAL TOLERANCES LINEAR DIMENSIONS UP TO 18 ±0.15 > 18 TO 80 ±0.25 > 80 ±0.4 ANGLES ±30'	CASTING TOLERANCES LINEAR DIMENSIONS ±(0.5%+1MM) THICKNESS ±0.2 (MIN. ±0.5mm) ANGLES ±2'	FORGING TOLERANCES LINEAR DIMENSIONS UP TO 18 ±0.5-0.3 > 18 TO 80 ±1-0.5 > 80 ±2 -0.8 ANGLES ±1'	UNLESS OTHERWISE SPECIFIED ROUND EDGES 0.3 AND CHAMFER 0.3x45° SURFACE MARKED --- REQUIRE STOCK MATERIAL TO BE REMOVED AT ASSEMBLY
--	---	--	--

CBOM	07829062017-00	STATUS OF DRG	
AGREED	NAME	SIGN	DATE
DABG-T	SUMIT	Sd/-	5.12.24

TYPE OF PRODUCT		SRGM 76/62	
OR		NAME OF CUSTOMER/PROJECT	

GRADE OF UNTOL.DIM	M/CG.-C/M/F AA0230208
WELDING-#/B/Ø/Ø	AA0621104
GAS CUTTING	T3'AA0621101

NAME	SIGN	DATE	NO. OF VAR
DRN SANDEEP	Sd/-	16.12.2024	---
CHD HARENDRA	Sd/-	16.12.2024	---
APPD SK SINGH	Sd/-	16.12.2024	---

REV	DATE	ALTERED CHECKED	REV	DATE	ALTERED CHECKED
-----	------	-----------------	-----	------	-----------------

DEPT DPE	SCALE NTS	WEIGHT (KG)	REF. TO ASSY. DRG.	ITEM No.	NO. OF ITEMS
CODE 4260			17829218012	1	---

TITLE : TOOL BOX-3 WITH PARTITIONS	CARD CODE	DRAWING NO. 17829218804	NO. OF SHEETS -04
------------------------------------	-----------	-------------------------	-------------------

INVENTORY NO. SIGN. & DATE REF. DRG. NO. 157892119-01  
 PROPRIETARY DATA OF DTD MELARA SPA  
 LIMITED RIGHTS OF TECHNICAL DATA  
 THE TECHNICAL DATA SET FORTH HEREIN IS SUBJECT TO THE LICENSE AGREEMENT BETWEEN DTD MELARA SPA AND BHARAT HEAVY ELECTRICALS LTDZ  
 THE TECHNICAL DATA CONTAINED HEREIN IS RESTRICTED AS TO USE, REPLICATION OR DISCLOSURE AS PER TERMS AND CONDITIONS OF THE LICENSE AGREEMENT

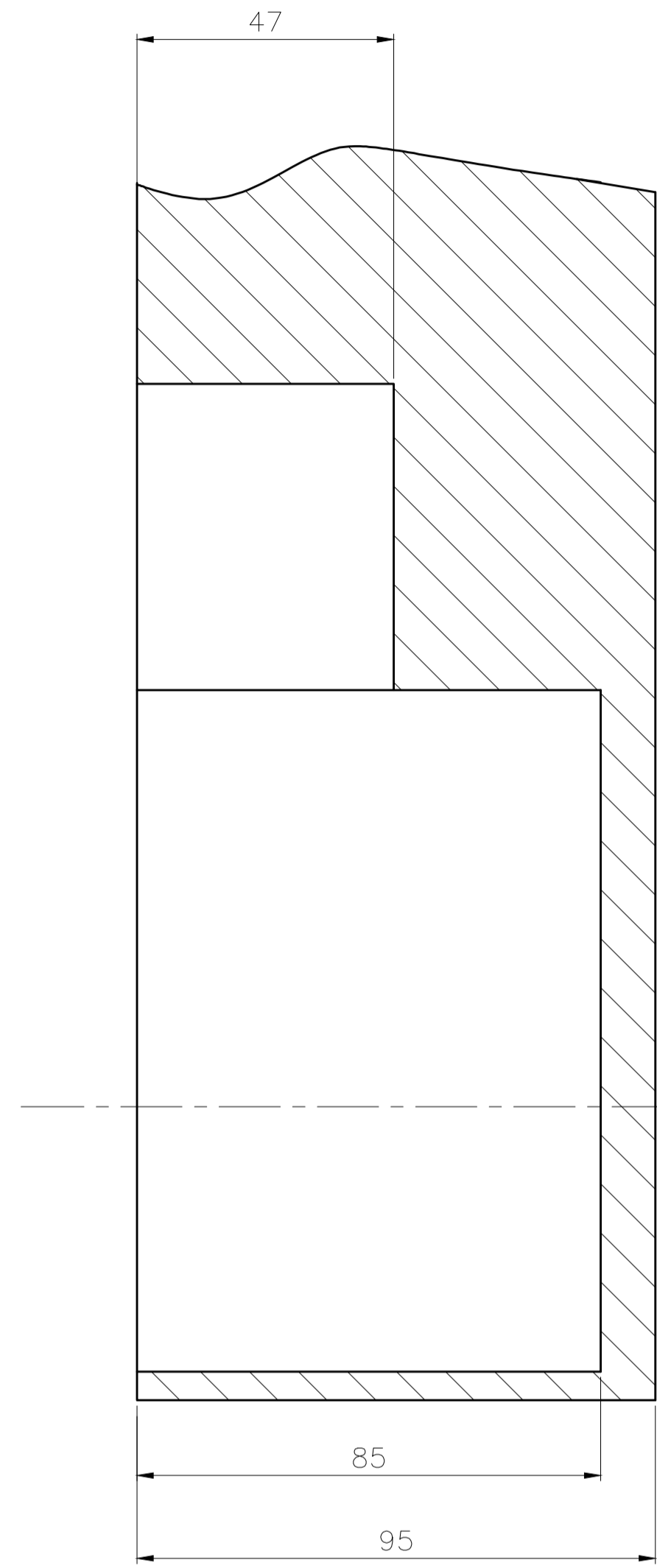

SECTION A-A

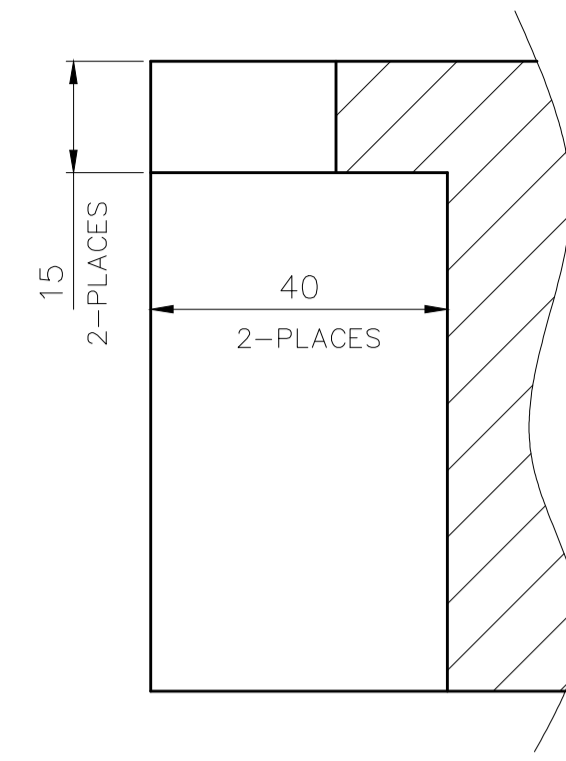

SECTION B-B

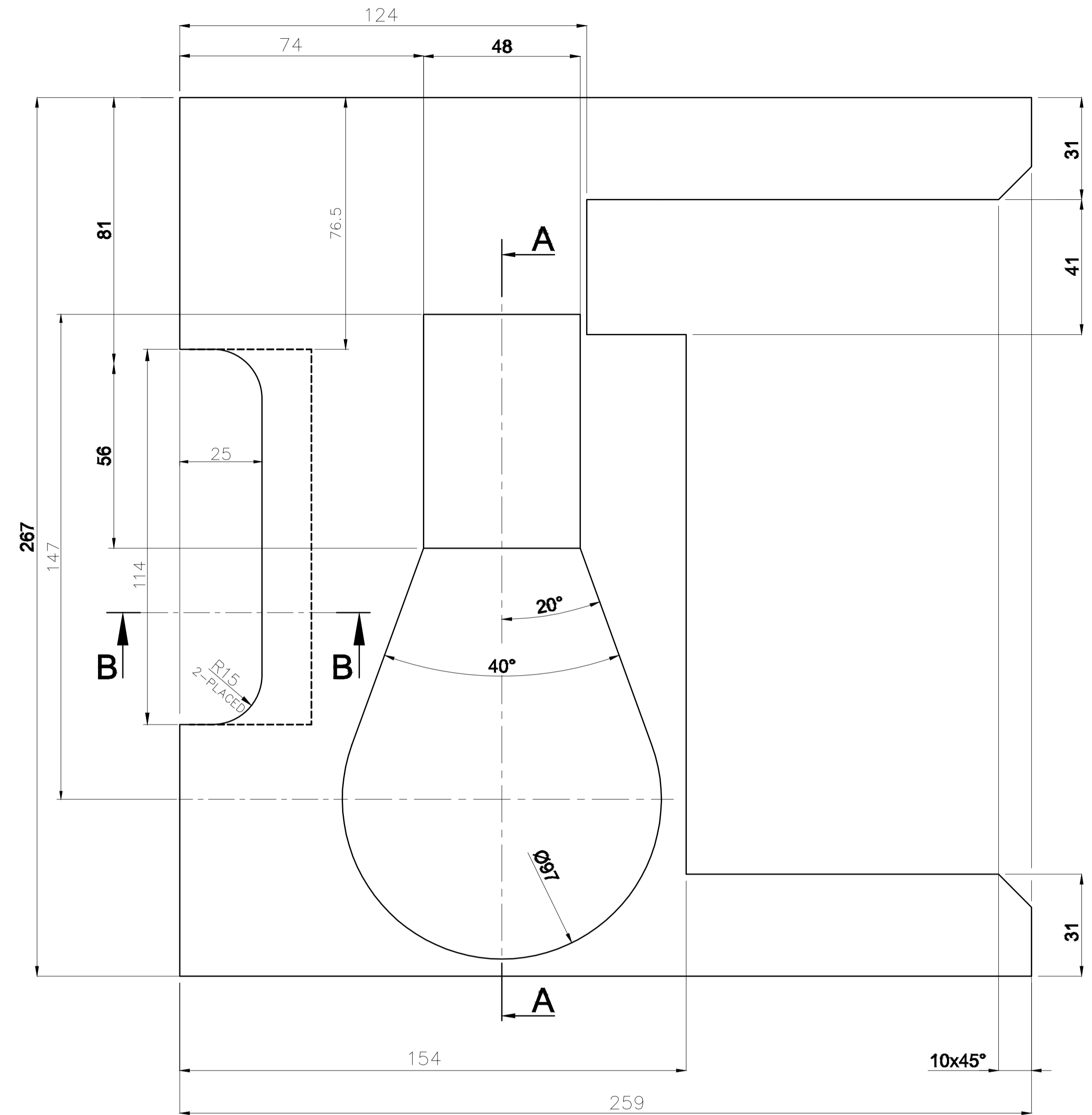

**TECHNICAL REQUIREMENTS**

1. MATERIAL- SHEESHAM WOOD WITH BASE PLATE OF PLYWOOD (THK-10MM).
2. TREATMENT- LACQUERING ALL OVER.
3. ALL INNER DIMENSIONS OF LAYOUT ARE FOR REFERENCE ONLY AND MAY BE CHANGED DEPENDING ON TOOL PLACEMENT AND SUPPLIER HAS TO MODIFY SUITABLY AT BHEL HARIDWAR-WORKS.

GENERAL TOLERANCES LINEAR DIMENSIONS UP TO 18 ±0.15 > 18 TO 80 ±0.25 > 80 ±0.4 ANGLES ±30'	CASTING TOLERANCES LINEAR DIMENSIONS ±(0.5%+1MM) THICKNESS ±0.2 (MIN. ±0.5mm) ANGLES ±2'	FORGING TOLERANCES LINEAR DIMENSIONS UP TO 18 ±0.5-0.3 > 18 TO 80 ±1 -0.5 > 80 ±2 -0.8 ANGLES ±1'	UNLESS OTHERWISE SPECIFIED ROUND EDGES 0.3 AND CHAMFER 0.3x45° SURFACE MARKED --- REQUIRE STOCK MATERIAL TO BE REMOVED AT ASSEMBLY
--	---	---	--

CBOM	07829062017-00	STATUS OF DRG	
AGREED	NAME	SIGN	DATE
DABG-T	SUMIT	Sd/-	5.12.24

TYPE OF PRODUCT		SRGM 76/62	
OR		NAME OF CUSTOMER/PROJECT	

GRADE OF UNTOL.DIM	
M/CG.-C/M/F	AA0230208
WELDING-#/B/φ/∅	AA0621104
GAS CUTTING	T3'AA0621104

NAME	SIGN	DATE	NO. OF VAR
DRN SANDEEP	Sd/-	16.12.2024	---
CHD HARENDRA	Sd/-	16.12.2024	---
APPD SK SINGH	Sd/-	16.12.2024	---

REV	DATE	ALTERED	REV	DATE	ALTERED
		CHECKED			CHECKED

DEPT DPE	SCALE	WEIGHT (KG)	REF. TO ASSY. DRG.	ITEM No.	NO. OF ITEMS
CODE 4260	NTS	-	17829218012	1	---

TITLE :	CARD CODE	DRAWING NO.	NO. OF SHEETS
TOOL BOX-3 WITH PARTITIONS	---	17829218804	-03



FIRST ANGLE PROJECTION

(ALL DIMENSIONS ARE IN mm)

17829218831 DRG. NO.

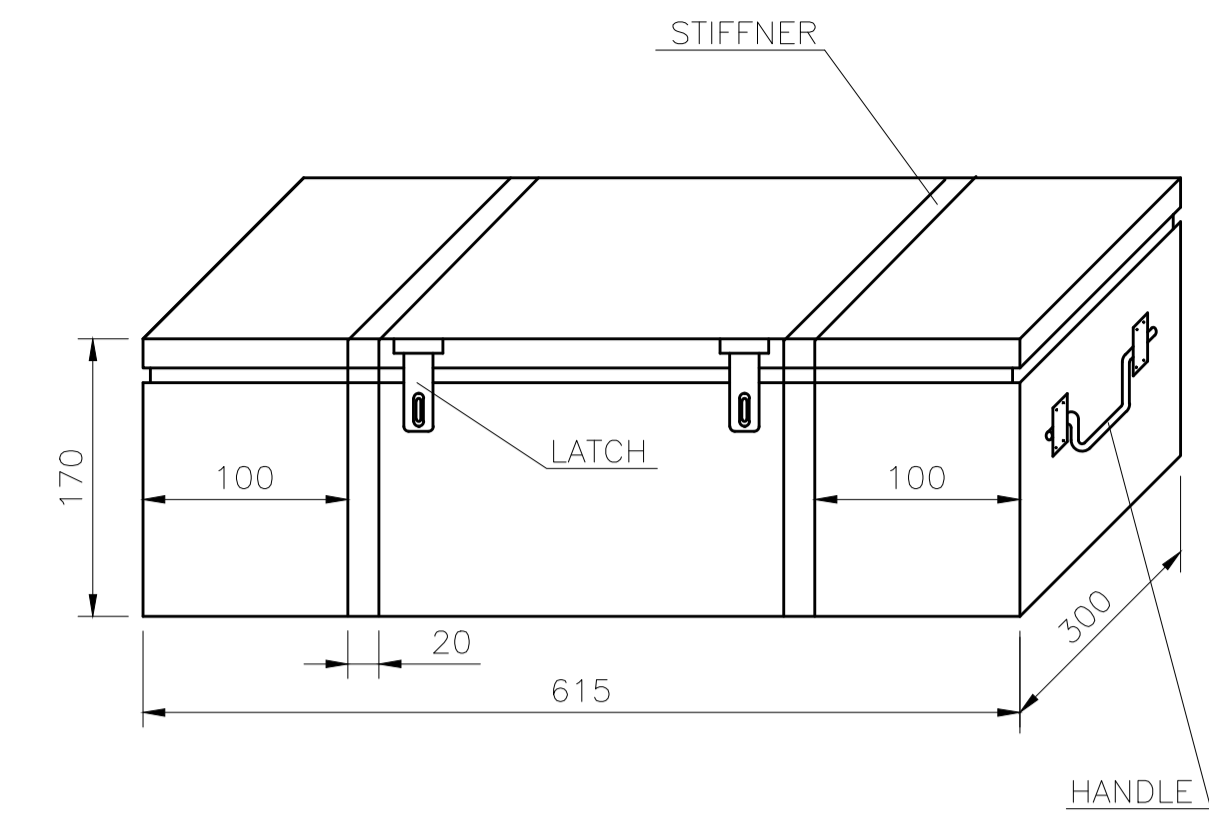
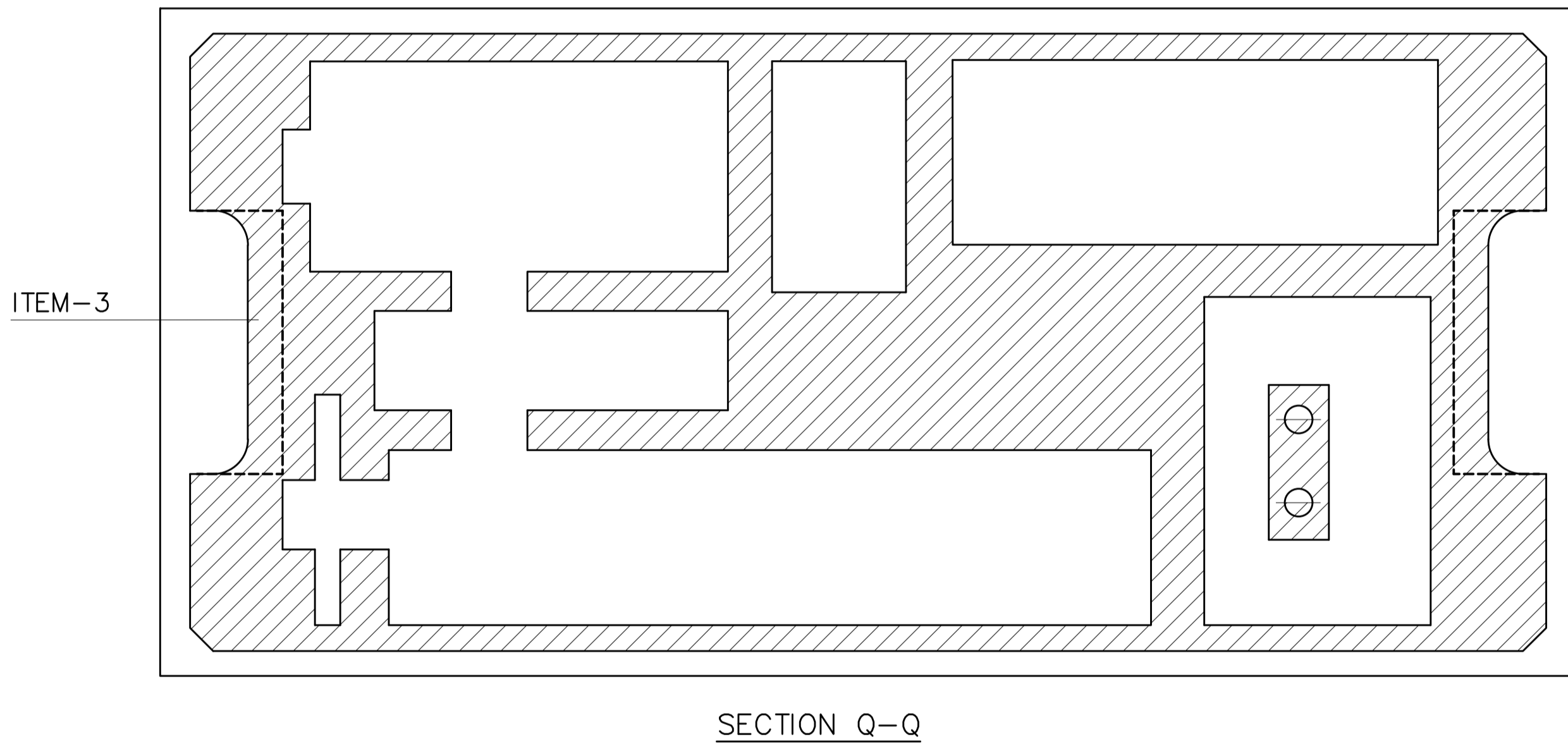
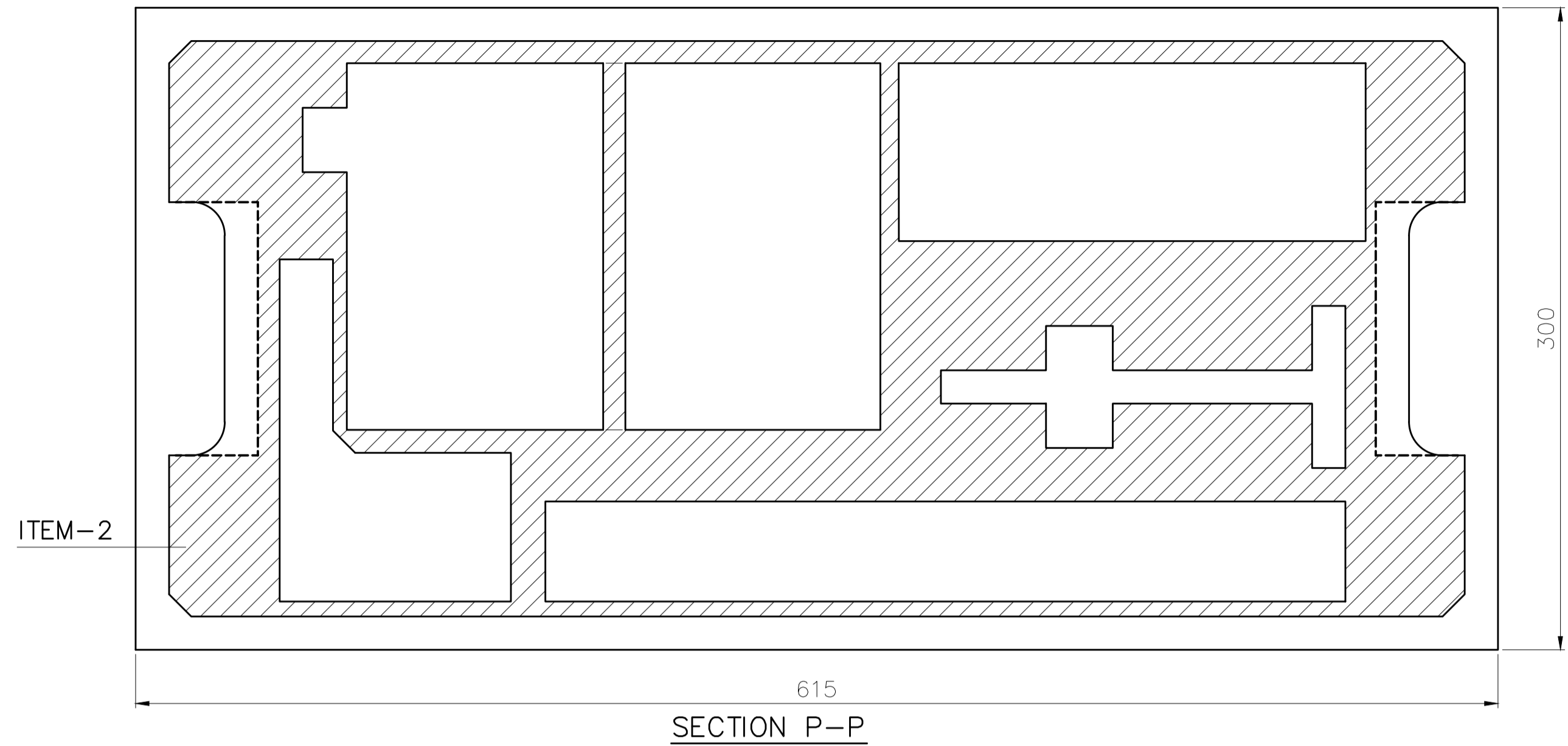

ITEM-1  
CASE

NOTES:

- COVER TO BE MADE FROM STEEL SHEET OF GAUGE 18 (~ 1.2 MM) AND BOX TO BE MADE FROM STEEL SHEET OF GAUGE 20 (~ 1.0 MM)
- ALL DIM. OF BOX ARE INTERNAL.
- TWO NOS STIFFNERS TO BE PROVIDED AROUND THE BOX AS SHOWN.
- HINGES ARE TO BE PROVIDED ON BACK SIDE TO OPEN THE COVER.
- FINAL PROTECTIVE FINISH - GREY PAINT, SHADE AS PER INDENTORS CHOICE.

PROPRIETARY DATA OF DTD MELARA SPA  
 LIMITED RIGHTS OF TECHNICAL DATA  
 THE TECHNICAL DATA SET FORTH HEREIN IS SUBJECT TO THE LICENSE AGREEMENT BETWEEN DTD MELARA SPA AND BHARAT HEAVY ELECTRICALS LTD  
 THE TECHNICAL DATA CONTAINED HEREIN IS RESTRICTED AS TO USE, REPRODUCTION OR DISCLOSURE AS PER TERMS AND CONDITIONS OF THE LICENSE AGREEMENT

TECHNICAL REQUIREMENTS

- IDENTIFICATION AS PER HW0400397

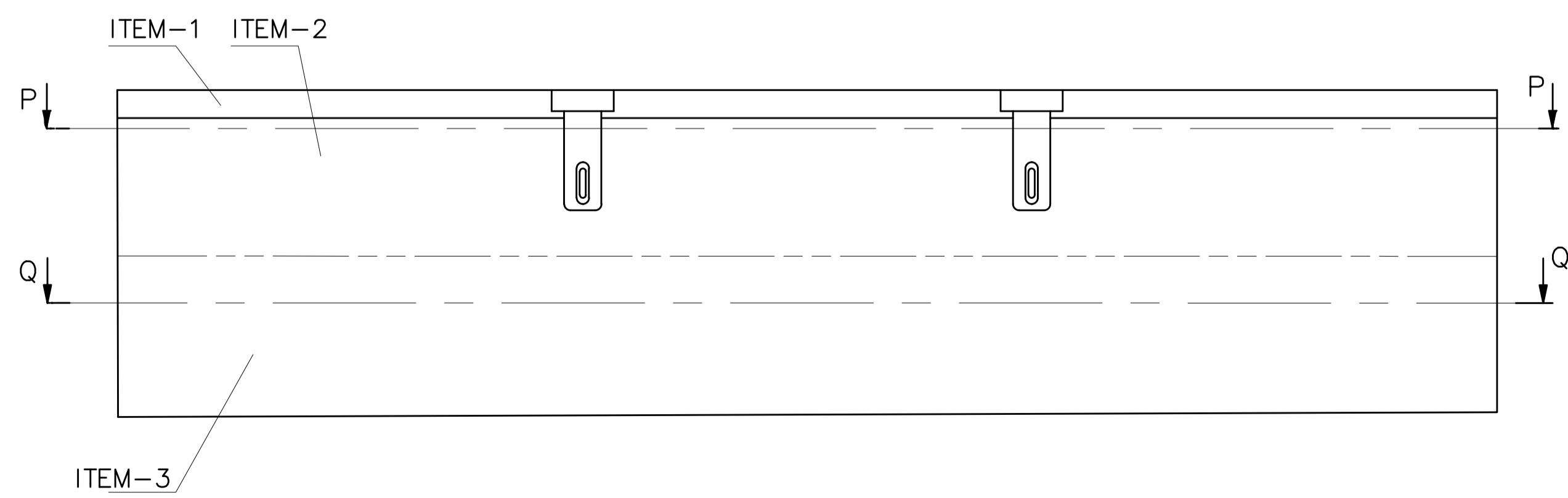

GENERAL TOLERANCES LINEAR DIMENSIONS UP TO 18 ±0.15 > 18 TO 80 ±0.25 > 80 ±0.4		CASTING TOLERANCES LINEAR DIMENSIONS ±(0.5%+1MM) THICKNESS ±8% (MIN. ±0.5mm) ANGLES ±2°		FORGING TOLERANCES LINEAR DIMENSIONS UP TO 18 +0.5-0.3 > 18 TO 80 +1 -0.5 > 80 +2 -0.8		UNLESS OTHERWISE SPECIFIED ROUND EDGES 0.3 AND CHAMFER 0.3x45° SURFACE MARKED --- REQUIRE STOCK MATERIAL TO BE REMOVED AT ASSEMBLY																
CBOM 07829062017-00		STATUS OF DRG		TYPE OF PRODUCT OR NAME OF CUSTOMER/PROJECT																		
AGREED DEPT		NAME		SIGN		DATE																
DABG-T		SUMIT		Sd/-		5.12.24																
GRADE OF UNTOL.DIM				SRGM 76/62																		
M/CG.-G/M/F AA0230208				BHARAT HEAVY ELECTRICALS LTD																		
WELDING-K/B/G/P AA0621104				RANIPUR, HARDWAR																		
GAS CUTTING T3'AA0621104				<table border="1"> <tr> <th>DRN</th> <th>NAME</th> <th>SIGN</th> <th>DATE</th> <th>NO. OF VAR</th> </tr> <tr> <td>CHD</td> <td>HARENDRA</td> <td>Sd/-</td> <td>16.12.2024</td> <td>---</td> </tr> <tr> <td>APPD</td> <td>SK SINGH</td> <td>Sd/-</td> <td>16.12.2024</td> <td>---</td> </tr> </table>				DRN	NAME	SIGN	DATE	NO. OF VAR	CHD	HARENDRA	Sd/-	16.12.2024	---	APPD	SK SINGH	Sd/-	16.12.2024	---
DRN	NAME	SIGN	DATE	NO. OF VAR																		
CHD	HARENDRA	Sd/-	16.12.2024	---																		
APPD	SK SINGH	Sd/-	16.12.2024	---																		
REV	DATE	ALTERED	REV	DATE	ALTERED	DEPT DPE	SCALE	WEIGHT (KG)	REF. TO ASSY. DRG.	ITEM No.	NO. OF ITEMS											
		CHECKED			CHECKED	CODE 4260	NTS	-	17829218013	1	---											
TITLE : TOOL BOX-4 WITH PARTITIONS								CARD CODE	DRAWING NO.													
								---	17829218831													
								SHEET No.	-01		No. OF SHEETS	-04										

17829218831 DRG. NO.

12.5 ALL OVER UNLESS OTHERWISE STATED

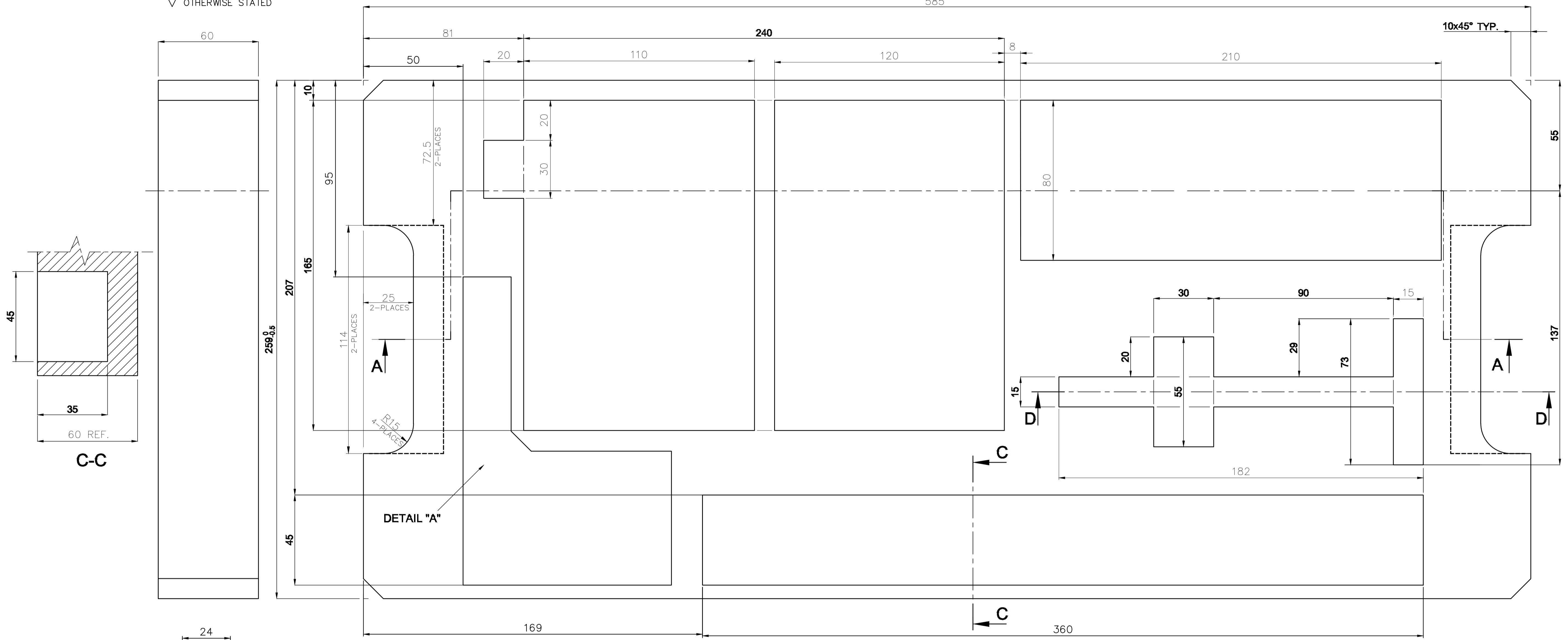

PROPRIETARY DATA OF DTD MELARA SPA LIMITED RIGHTS OF TECHNICAL DATA THE TECHNICAL DATA SET FORTH HEREIN IS SUBJECT TO THE LICENSE AGREEMENT BETWEEN DTD MELARA SPA AND BHARAT HEAVY ELECTRICALS LTD. THE TECHNICAL DATA SET FORTH HEREIN IS RESTRICTED AS TO USE, REPRODUCTION OR DISCLOSURE AS PER TERMS AND CONDITIONS OF THE LICENSE AGREEMENT.

DETAIL "A"

TECHNICAL REQUIREMENTS

- MATERIAL- SHEESHAM WOOD WITH BASE PLATE OF PLYWOOD (THK-10MM).
- TREATMENT- LACQUERING ALL OVER.
- ALL INNER DIMENSIONS OF LAYOUT ARE FOR REFERENCE ONLY AND MAY BE CHANGED DEPENDING ON TOOL PLACEMENT AND SUPPLIER HAS TO MODIFY SUITABLY AT BHEL HARIDWAR-WORKS.

TECHNICAL REQUIREMENTS

1. IDENTIFICATION AS PER HW0400397

CBOM 07829062017-00		STATUS OF DRG		TYPE OF PRODUCT OR NAME OF CUSTOMER/PROJECT							
AGREED DEPT	NAME	SIGN	DATE	SRGM 76/62							
DABG-T	SUMIT	Sd/-	5.12.24	BHARAT HEAVY ELECTRICALS LTD RANIPUR, HARDWAR							
REV	DATE	ALTERED CHECKED	REV	DATE	ALTERED CHECKED	DEPT DPE	SCALE	WEIGHT (KG)	REF. TO ASSY. DRG.	ITEM No.	NO. OF ITEMS
						CODE 4260	NTS	-	17829218013	1	--
GRADE OF UNTOL.DIM				TITLE : TOOL BOX-4 WITH PARTITIONS				DRAWING NO. 17829218831		SHEET No. -02 No. OF SHEETS -04	
M/CG.-G/M/F AA0230208				WELDING-A/B/G/P AA0621104				GAS CUTTING T3'AA0621104			



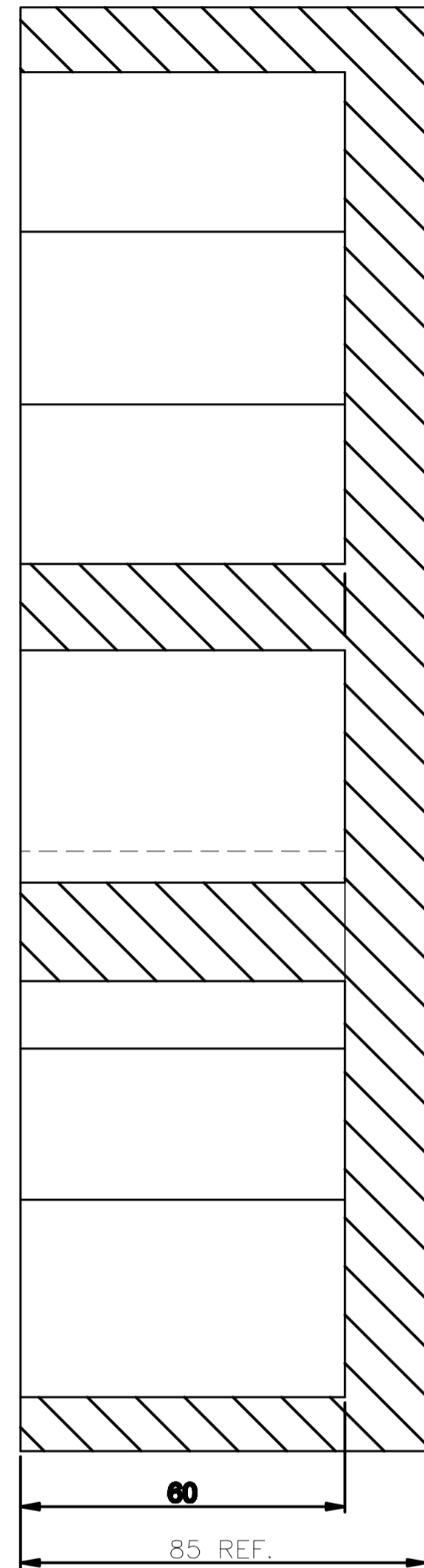

**A-A**  
(FROM SH- 3)

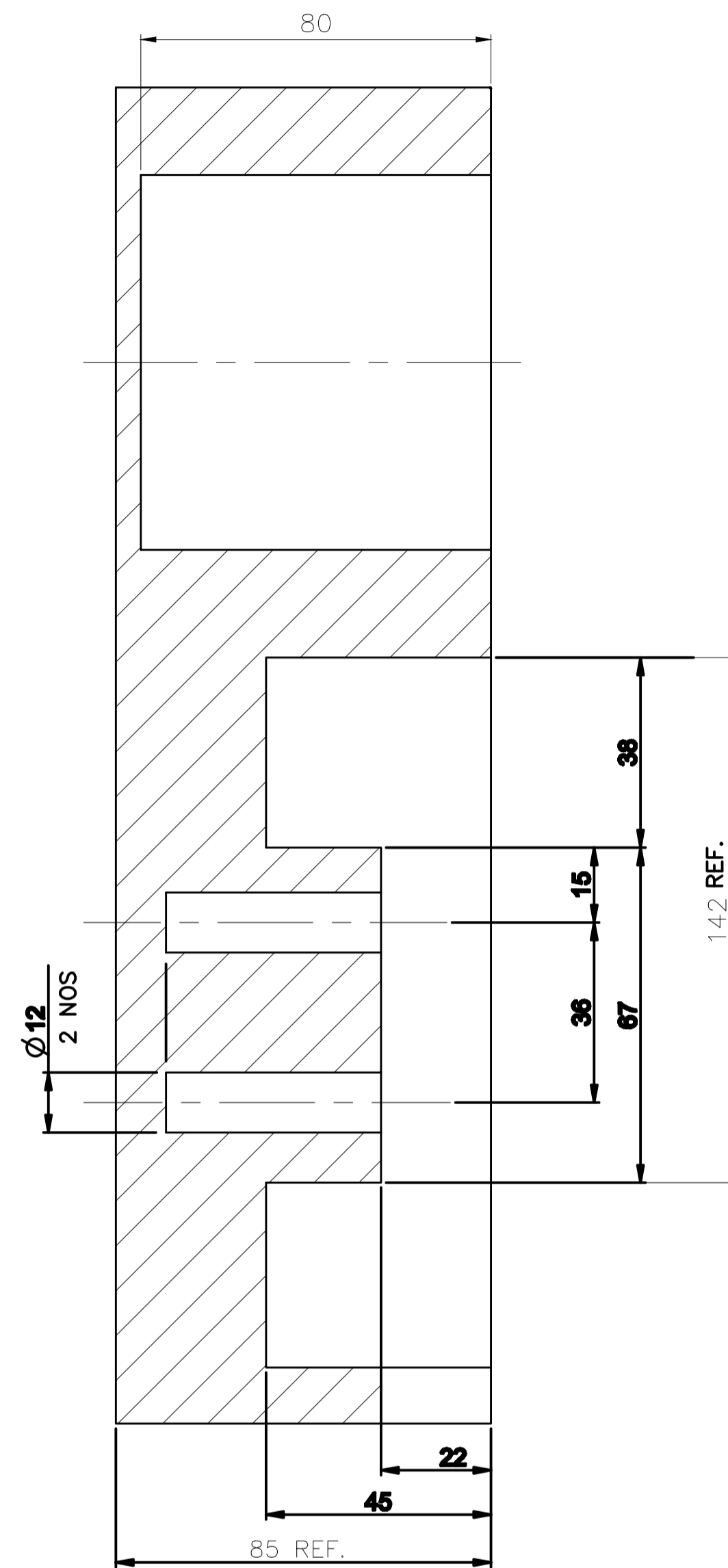

**C-C**  
(FROM SH- 3)

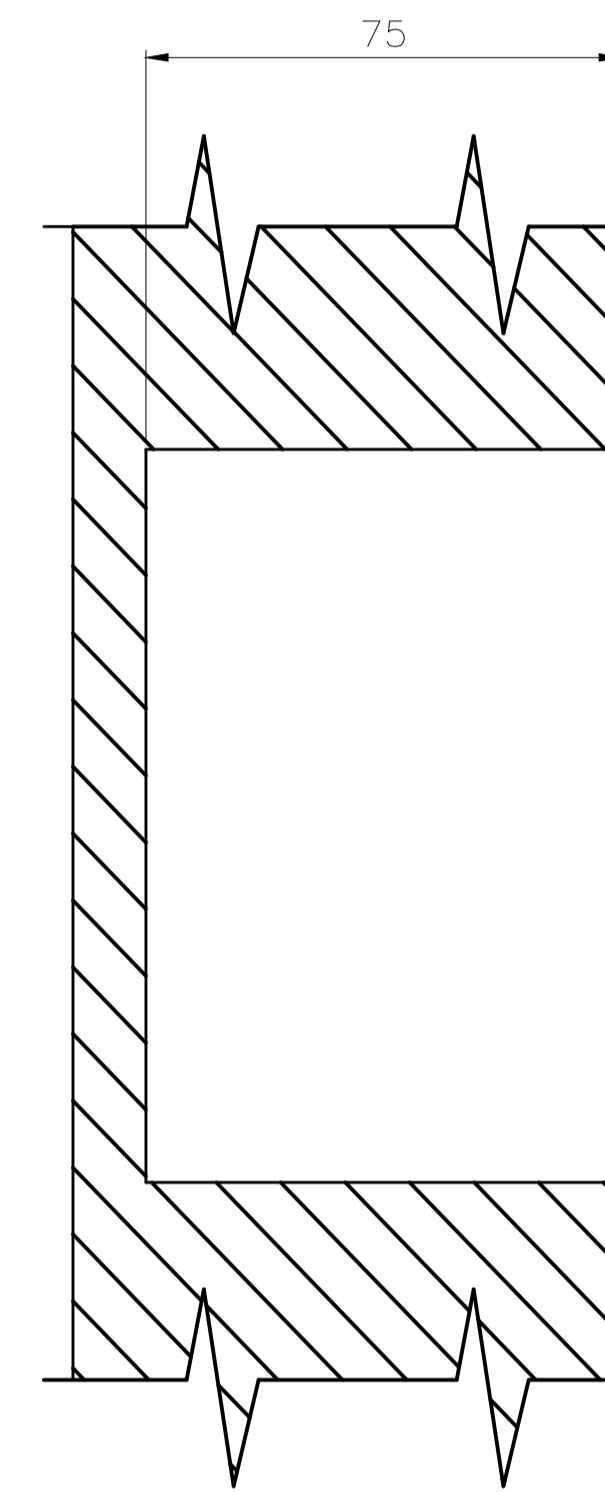

**D-D**  
(FROM SH- 3)

**TECHNICAL REQUIREMENTS**

1. IDENTIFICATION AS PER HW0400397

GENERAL TOLERANCES LINEAR DIMENSIONS UP TO 18 ±0.15 > 18 TO 80 ±0.25 > 80 ±0.4	CASTING TOLERANCES LINEAR DIMENSIONS ±(0.5%+1MM) THICKNESS ±8% (MIN. ±0.5mm) ANGLES ±2°	FORGING TOLERANCES LINEAR DIMENSIONS UP TO 18 +0.5-0.3 > 18 TO 80 +1 -0.5 > 80 +2 -0.8	UNLESS OTHERWISE SPECIFIED ROUND EDGES 0.3 AND CHAMFER 0.3x45° SURFACE MARKED --- REQUIRE STOCK MATERIAL TO BE REMOVED AT ASSEMBLY
---	--	---	--

CBOM 07829062017-00		STATUS OF DRG		TYPE OF PRODUCT OR NAME OF CUSTOMER/PROJECT		SRGM 76/62	
AGREED DEPT	NAME	SIGN	DATE	DRN	NAME	SIGN	DATE
DABG-T	SUMIT	Sd/-	5.12.24	CHD	HARENDRA	Sd/-	16.12.2024
GRADE OF UNTOL.DIM				Bharat Heavy Electricals Ltd RANIPUR, HARDWAR			
M/CG.-G/M/F AA0230208				APPD SK SINGH Sd/- 16.12.2024			
WELDING-K/B/G/P AA0621104				DEPT DPE			
GAS CUTTING T3'AA0621104				CODE 4260			
REV	DATE	ALTERED	REV	DATE	ALTERED	SCALE	WEIGHT (KG)
		CHECKED			CHECKED	NTS	-
REF. TO ASSY. DRG.				ITEM No.			
17829218013				1			
DRAWING NO.				CARD CODE			
17829218831				---			
SHEET No. -04/No. OF SHEETS -04				AI SIZE			

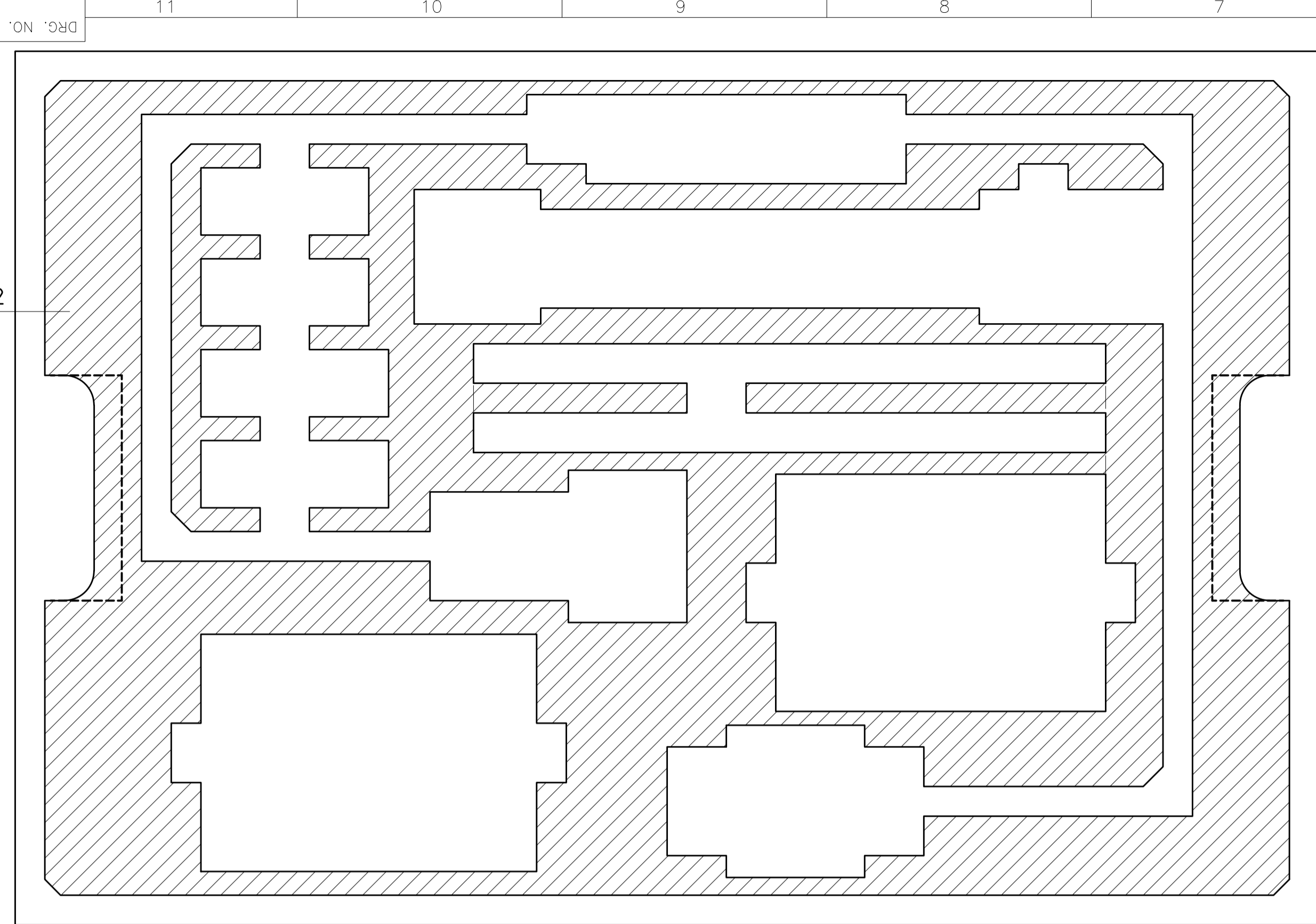

SECTION P-P

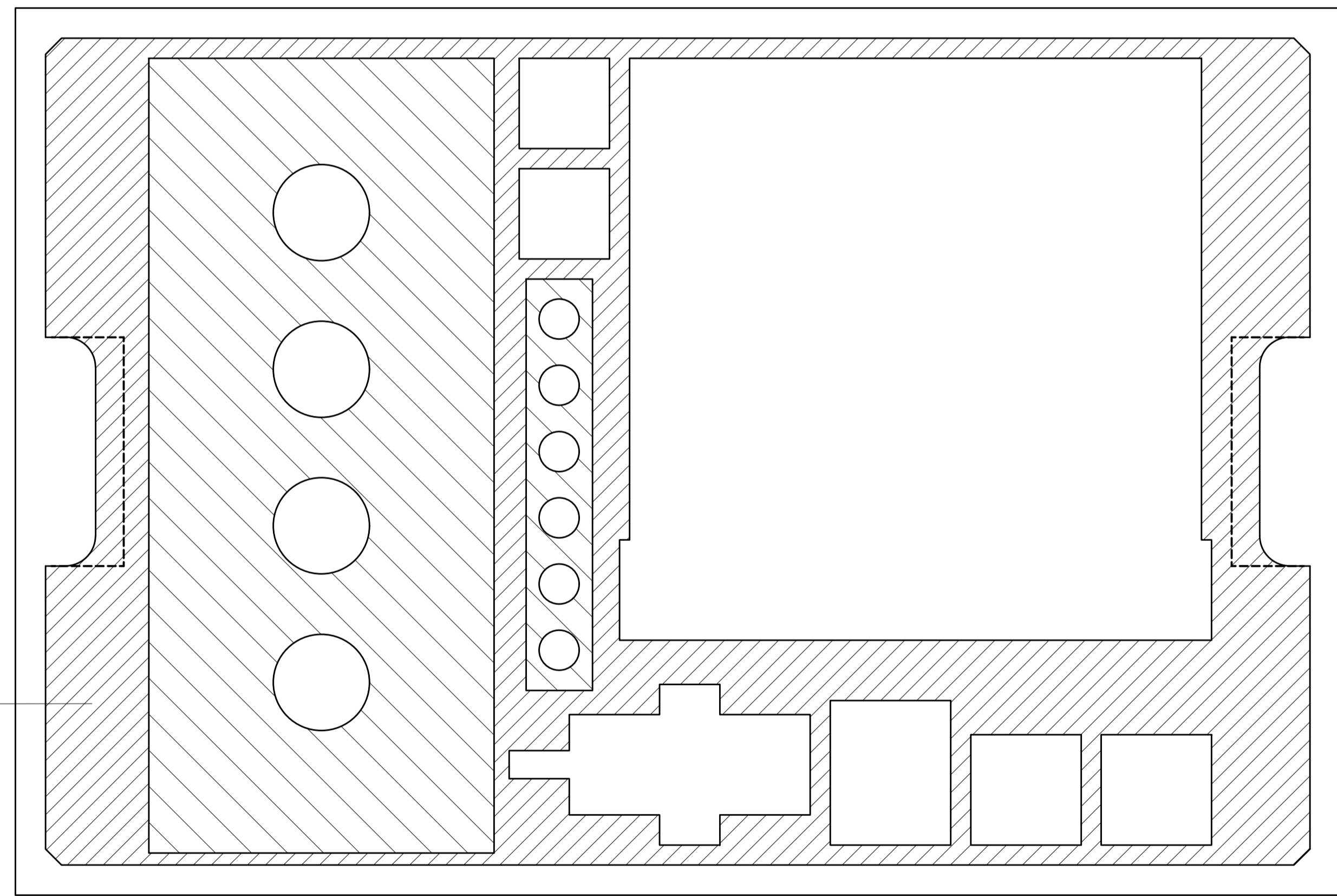

SECTION Q-Q

ITEM-1 CASE

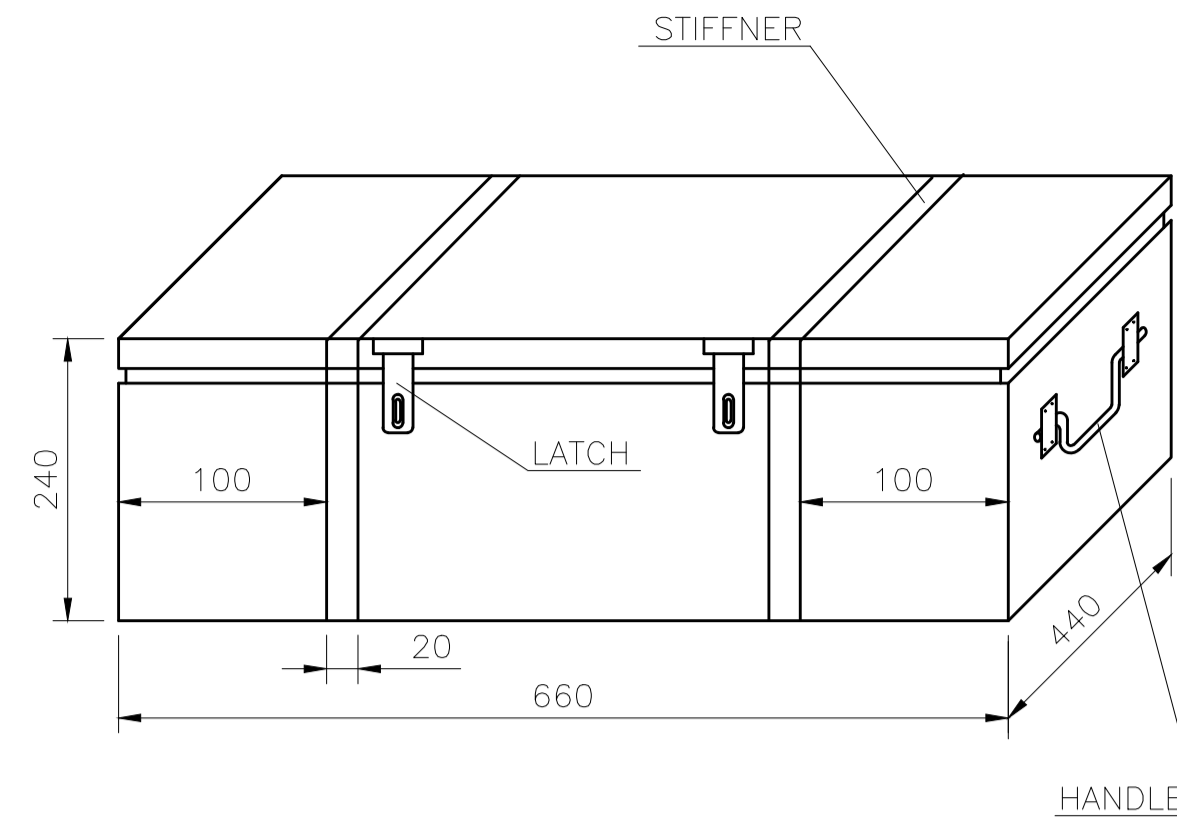

NOTES:

- COVER TO BE MADE FROM STEEL SHEET OF GAUGE 18 (~ 1.2 MM) AND BOX TO BE MADE FROM STEEL SHEET OF GAUGE 20 (~ 1.0 MM)
- ALL DIM. OF BOX ARE INTERNAL.
- TWO NOS STIFFNERS TO BE PROVIDED AROUND THE BOX AS SHOWN.
- HINGES ARE TO BE PROVIDED ON BACK SIDE TO OPEN THE COVER.
- FINAL PROTECTIVE FINISH - GREY PAINT, SHADE AS PER INDENTORS CHOICE.

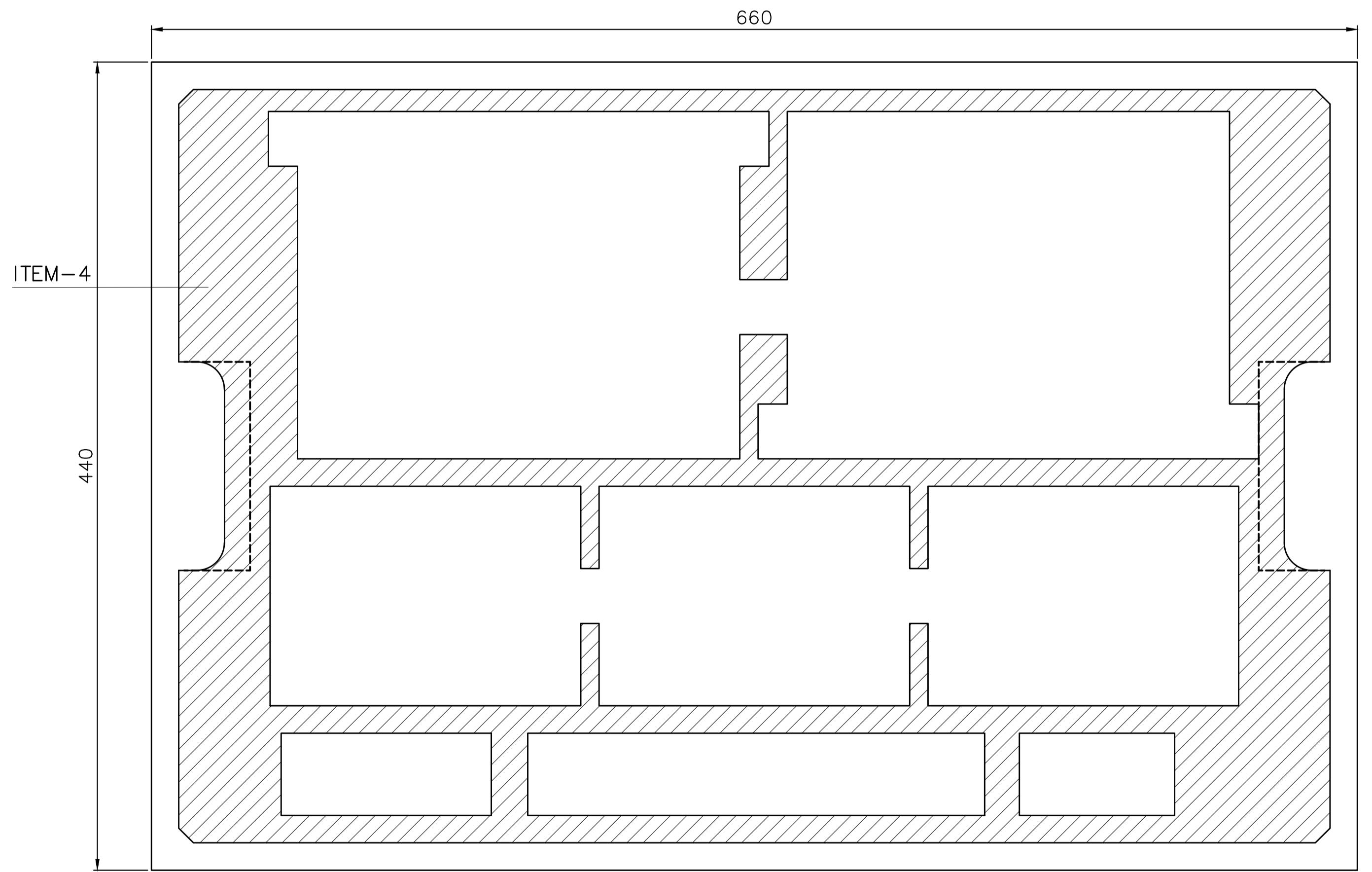

SECTION R-R

TECHNICAL REQUIREMENTS

- IDENTIFICATION AS PER HW0400397

GENERAL TOLERANCES LINEAR DIMENSIONS UP TO 18 ±0.15 > 18 TO 80 ±0.25 > 80 ±0.4	CASTING TOLERANCES LINEAR DIMENSIONS ±(0.5%+1MM) THICKNESS ±0.2 (MIN. ±0.5mm) ANGLES ±2'	FORGING TOLERANCES LINEAR DIMENSIONS UP TO 18 ±0.5-0.3 > 18 TO 80 ±1 -0.5 > 80 ±2 -0.8 ANGLES ±1'	UNLESS OTHERWISE SPECIFIED ROUND EDGES 0.3 AND CHAMFER 0.3x45° SURFACE MARKED --- REQUIRE STOCK MATERIAL TO BE REMOVED AT ASSEMBLY
---	---	---	--

CBOM 07829062017-00		STATUS OF DRG	
AGREED	NAME	SIGN	DATE
DABG-T	SUMIT	Sd/-	5.12.24
GRADE OF UNTOL.DIM			
M/CG.-C/M/F AA0230208			
WELDING-#/B/C/D AA0621104			
GAS CUTTING T3'AA0621104			
REV	DATE	ALTERED	CHECKED

TYPE OF PRODUCT OR NAME OF CUSTOMER/PROJECT		SRGM 76/62	
NAME	SIGN	DATE	NO. OF VAR
DRN SANDEEP	Sd/-	16.12.2024	
CHD HARENDRA	Sd/-	16.12.2024	
APPD SK SINGH	Sd/-	16.12.2024	
DEPT DPE	SCALE	WEIGHT (KG)	REF. TO ASSY. DRG.
CODE 4260	NTS	-	07829062014
TITLE : TOOL BOX-6 WITH PARTITIONS	CARD CODE	DRAWING NO.	ITEM No.
		17829218864	1
SHEET No. -01		No. OF SHEETS -04	



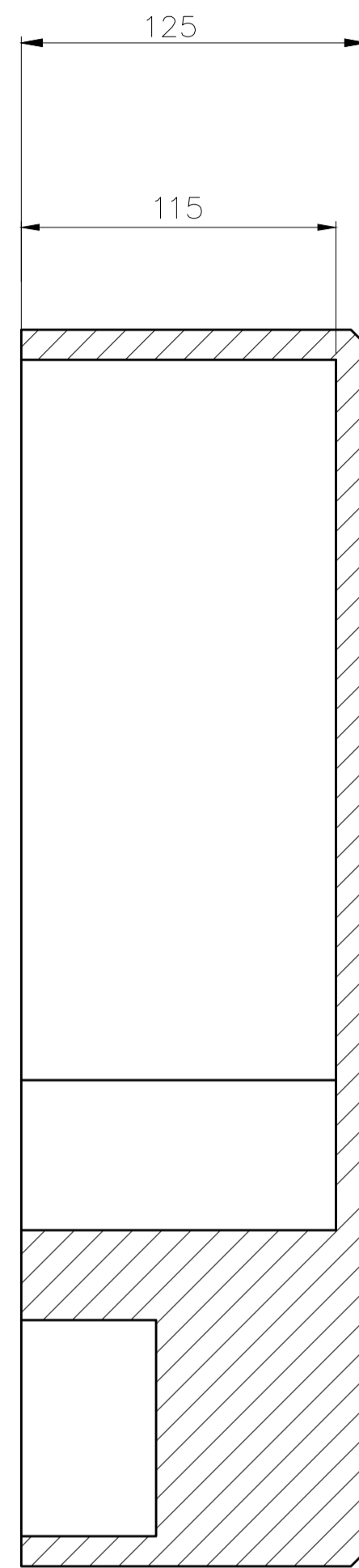

SECTION A-A

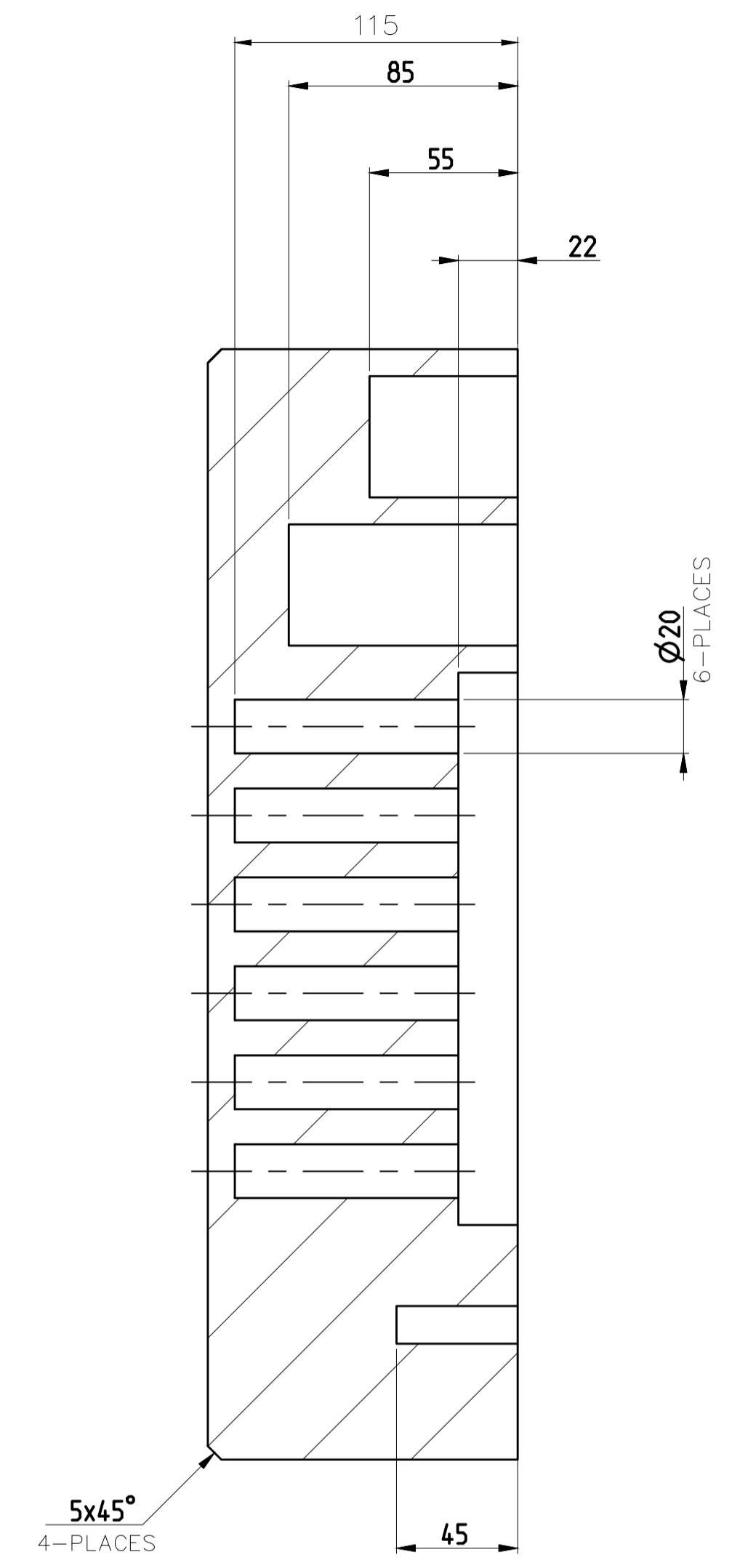
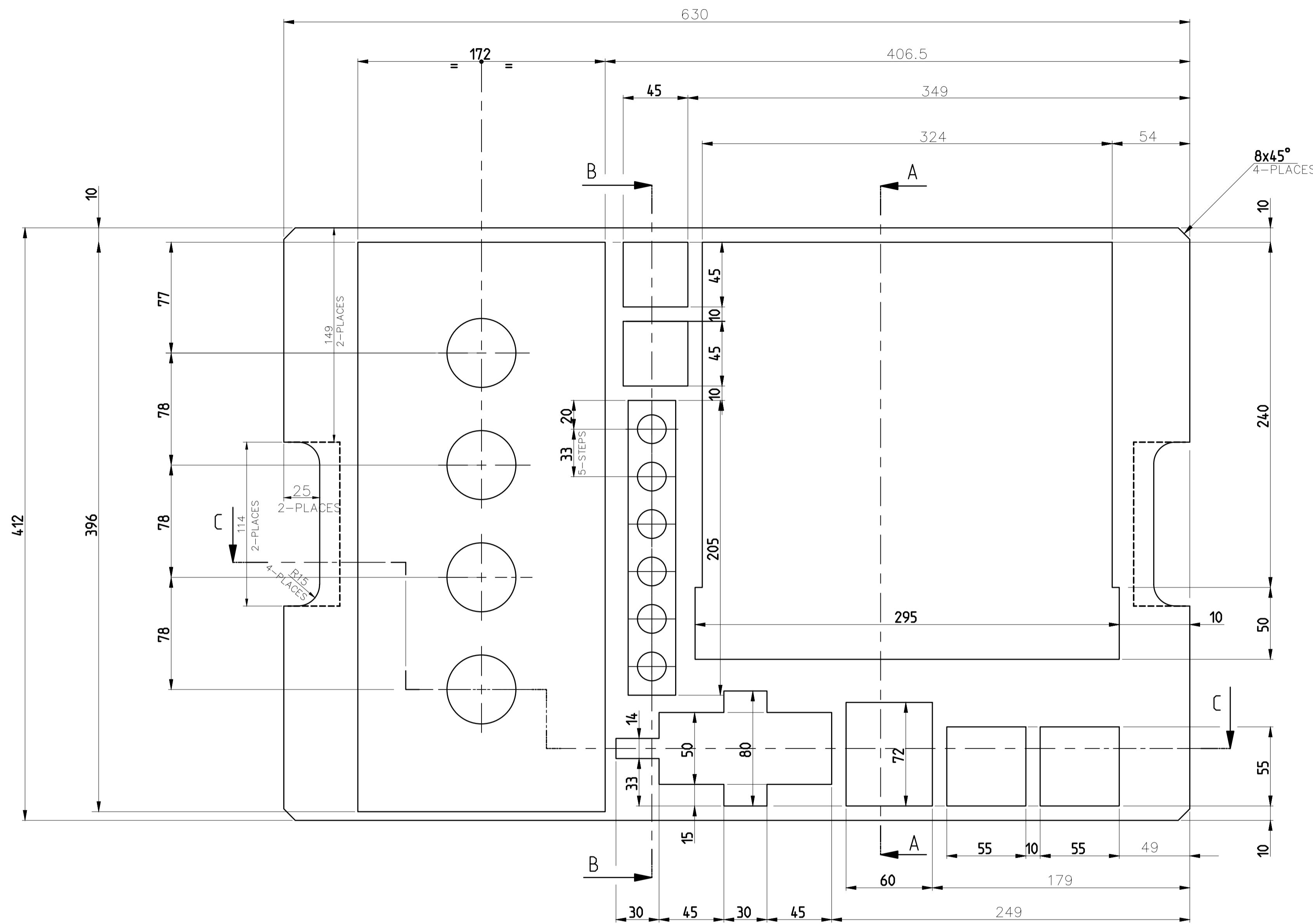

SECTION B-B

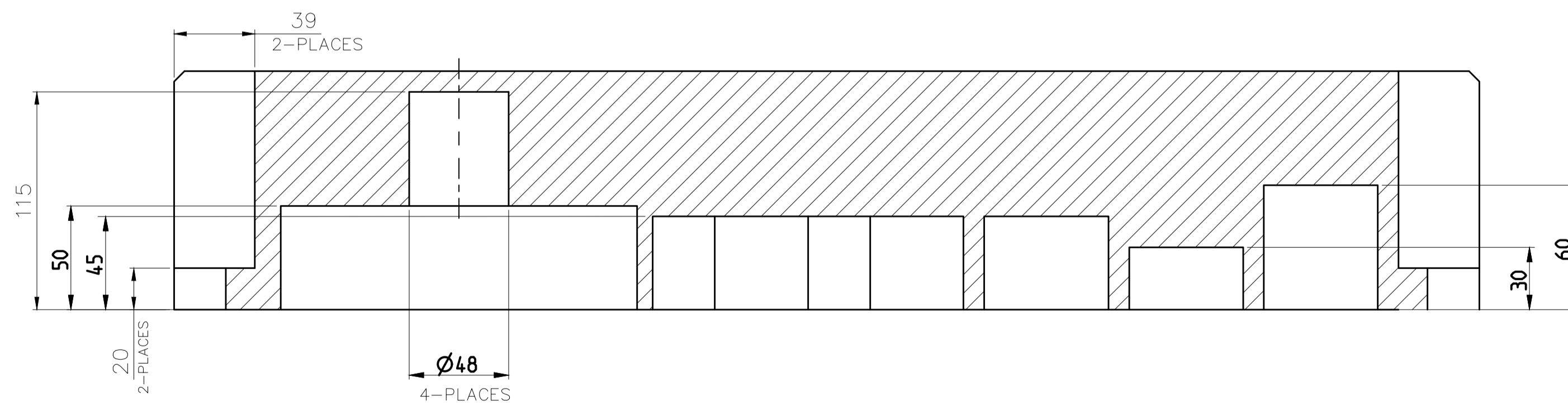

SECTION C-C

**TECHNICAL REQUIREMENTS**

1. MATERIAL- SHEESHAM WOOD WITH BASE PLATE OF PLYWOOD (THK-10MM).
2. TREATMENT- LACQUERING ALL OVER.
3. ALL INNER DIMENSIONS OF LAYOUT ARE FOR REFERENCE ONLY AND MAY BE CHANGED DEPENDING ON TOOL PLACEMENT AND SUPPLIER HAS TO MODIFY SUITABLY AT BHEL HARIDWAR-WORKS.

GENERAL TOLERANCES LINEAR DIMENSIONS UP TO 18 ±0.15 > 18 TO 80 ±0.25 > 80 ±0.4	CASTING TOLERANCES LINEAR DIMENSIONS ±(0.5%+1MM) THICKNESS ±0.2 (MIN. ±0.5mm) ANGLES ±1'	FORGING TOLERANCES LINEAR DIMENSIONS UP TO 18 ±0.5-0.3 > 18 TO 80 ±1-0.5 > 80 ±2 -0.8 ANGLES ±1'	UNLESS OTHERWISE SPECIFIED ROUND EDGES 0.3 AND CHAMFER 0.3x45° SURFACE MARKED --- REQUIRE STOCK MATERIAL TO BE REMOVED AT ASSEMBLY
---	---	--	--

CBOM 07829062017-00		STATUS OF DRG	
AGREED	NAME	SIGN	DATE
DABG-T	SUMIT	Sd/-	5.12.24
GRADE OF UNTOL.DIM			
M/CG.-Q/M/F AA0230208			
WELDING-#/B/Q/D AA0621104			
GAS CUTTING-T3'AA0621104			
REV	DATE	ALTERED CHECKED	REV

TYPE OF PRODUCT		SRGM 76/62	
OR		NAME OF CUSTOMER/PROJECT	
BHARAT HEAVY ELECTRICALS LTD		RANIPUR, HARDWAR	
DRN	NAME	SIGN	DATE
CHD	HARENDRA	Sd/-	16.12.2024
APPD	SK SINGH	Sd/-	16.12.2024
DEPT DPE	SCALE	WEIGHT (KG)	REF. TO ASSY. DRG.
CODE 4260	NTS	-	07829062014
TITLE : TOOL BOX-6 WITH PARTITIONS		CARD CODE	ITEM No.
			1
		DRAWING NO.	NO. OF ITEMS
		17829218864	---
		SHEET No. -03	No. OF SHEETS -04

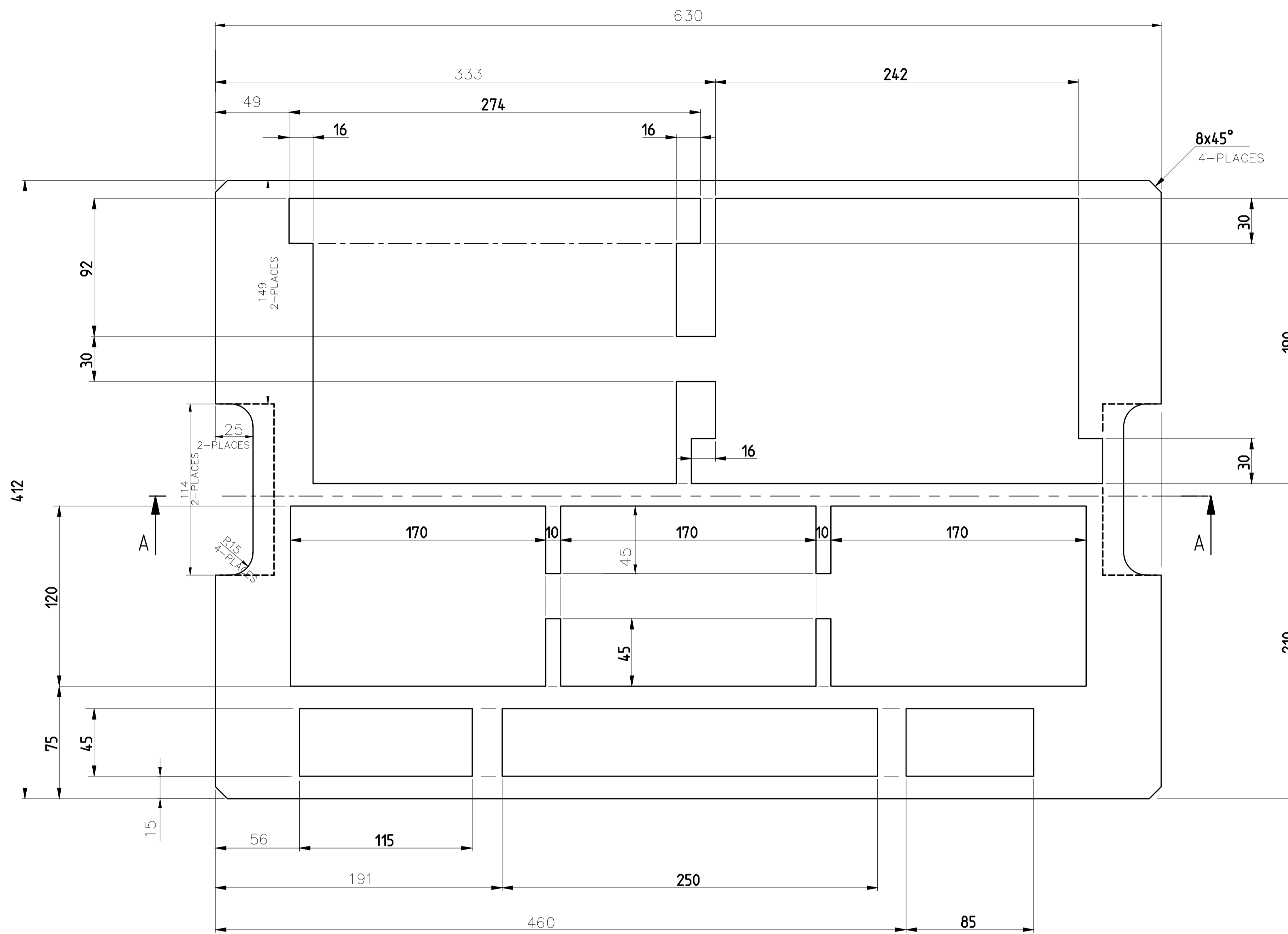

ALL SLOTS ARE 40 MM DEEP.

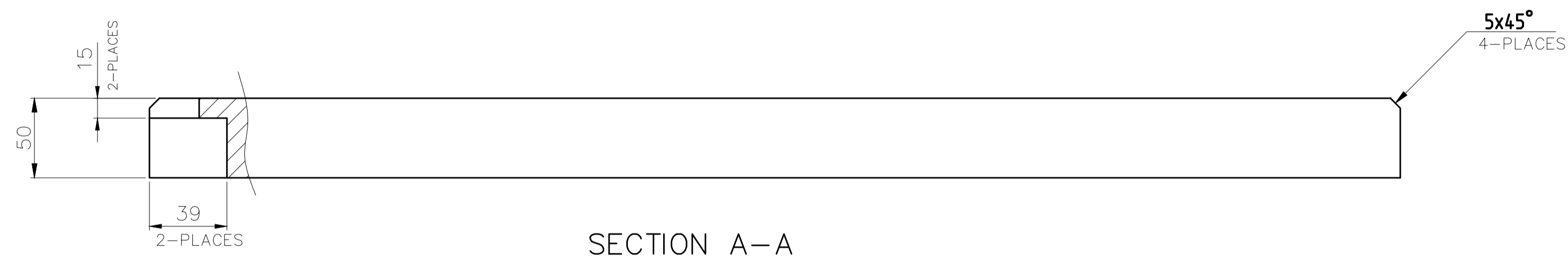

SECTION A-A

**TECHNICAL REQUIREMENTS**

1. MATERIAL- SHEESHAM WOOD WITH BASE PLATE OF PLYWOOD (THK-10MM).
2. TREATMENT- LACQUERING ALL OVER.
3. ALL INNER DIMENSIONS OF LAYOUT ARE FOR REFERENCE ONLY AND MAY BE CHANGED DEPENDING ON TOOL PLACEMENT AND SUPPLIER HAS TO MODIFY SUITABLY AT BHEL HARIDWAR-WORKS.

GENERAL TOLERANCES LINEAR DIMENSIONS UP TO 18 ±0.15 > 18 TO 80 ±0.25 > 80 ±0.4 ANGLES ±30'	CASTING TOLERANCES LINEAR DIMENSIONS ±(0.5%+1MM) THICKNESS ±0.4 (MIN. ±0.5mm) ANGLES ±2'	FORGING TOLERANCES LINEAR DIMENSIONS UP TO 18 ±0.5-0.3 > 18 TO 80 ±1 -0.5 > 80 ±2 -0.8 ANGLES ±1'	UNLESS OTHERWISE SPECIFIED ROUND EDGES 0.3 AND CHAMFER 0.3x45° SURFACE MARKED --- REQUIRE STOCK MATERIAL TO BE REMOVED AT ASSEMBLY
--	---	---	--

CBOM	07829062017-00	STATUS OF DRG	
AGREED	NAME	SIGN	DATE
DABG-T	SUMIT	Sd/-	5.12.24

TYPE OF PRODUCT		SRGM 76/62	
OR			
NAME OF CUSTOMER/PROJECT			

GRADE OF UNTOL.DIM			
M/CG.-C/M/F AA0230208			
WELDING-#/B/φ/δ AA0621104			
GAS CUTTING T3'AA0621104			
REV	DATE	ALTERED	CHECKED

DRN	NAME	SIGN	DATE	NO. OF VAR
CHD	HARENDRA	Sd/-	16.12.2024	
APPD	SK SINGH	Sd/-	16.12.2024	
DEPT	DPE	SCALE	WEIGHT (KG)	REF. TO ASSY. DRG.
CODE 4260		NTS	-	07829062014
TITLE : TOOL BOX-6 WITH PARTITIONS		CARD CODE	DRAWING NO.	ITEM No.
			17829218864	1
		SHEET No. -04		No. OF SHEETS -04

17829218822 DRG. NO.

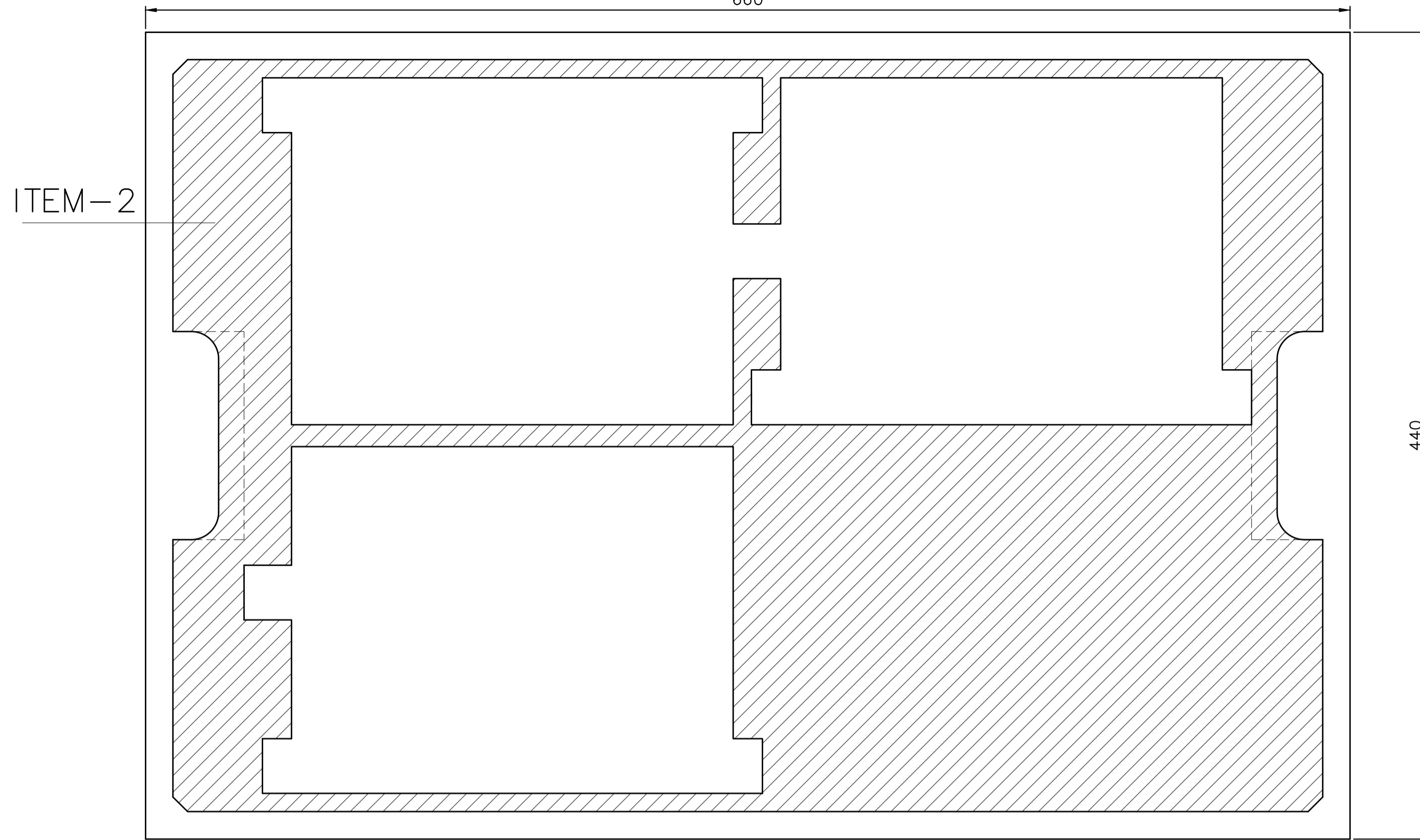

ITEM-3

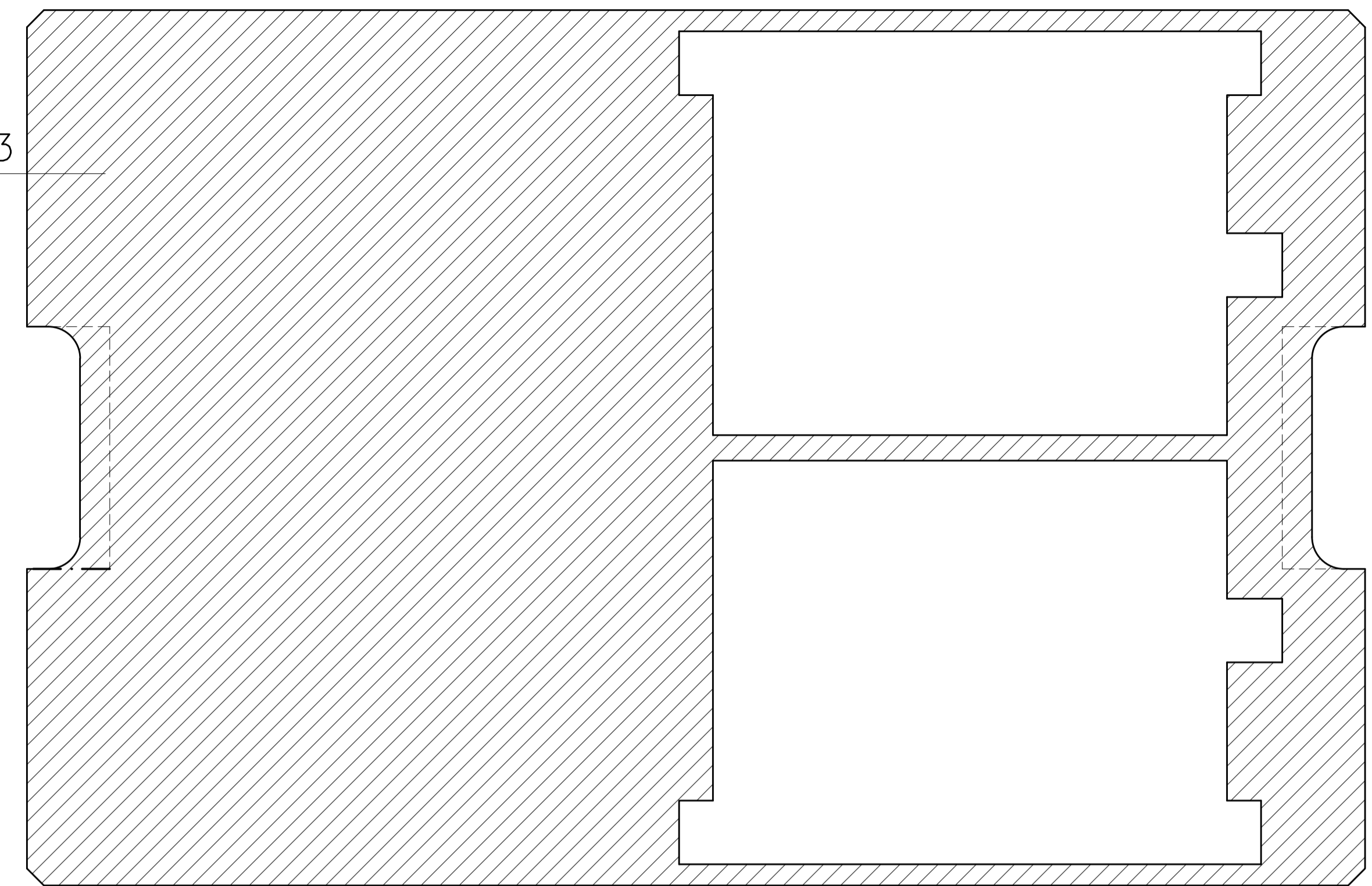

Q-Q

P-P

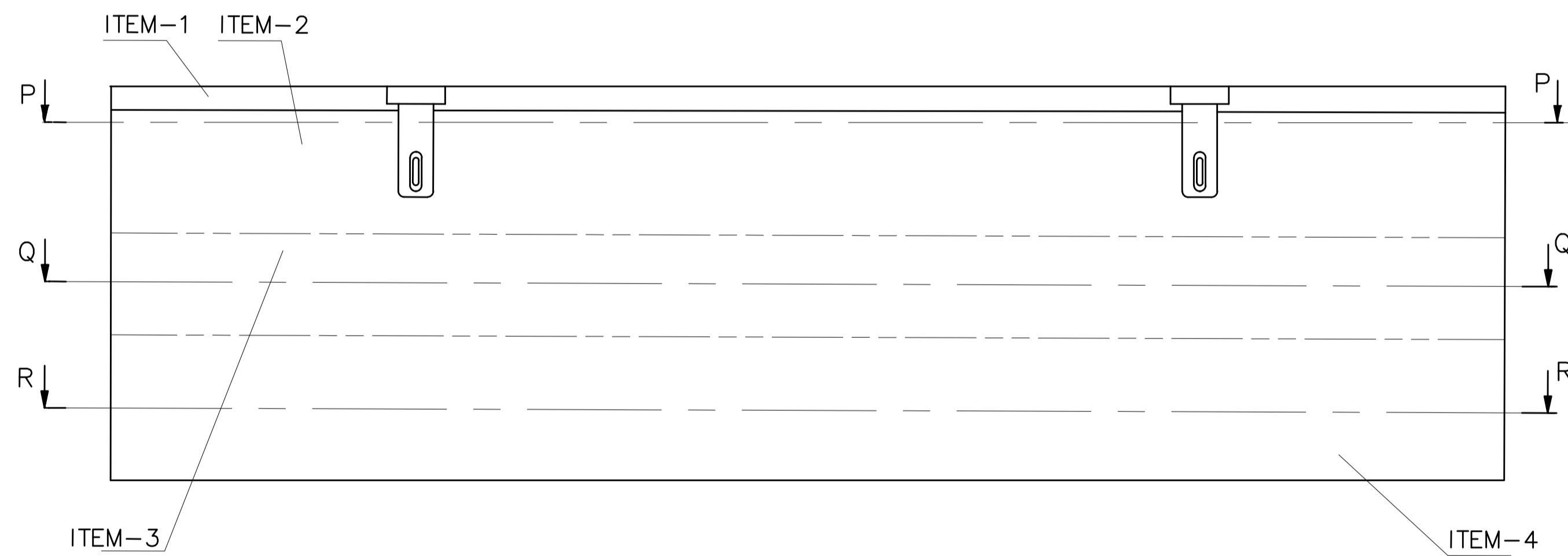

ITEM-4

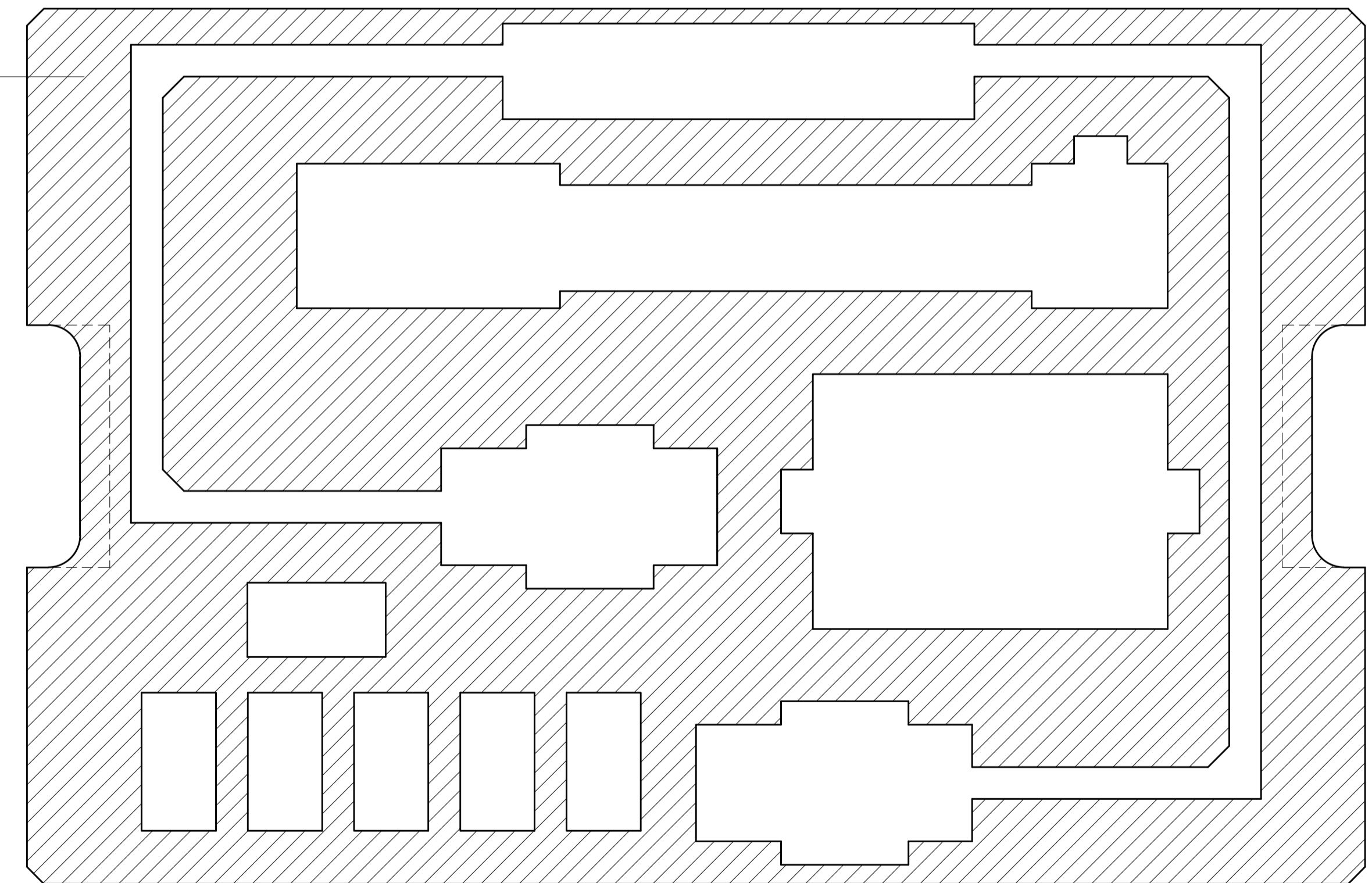

R-R

ITEM-1  
BOX

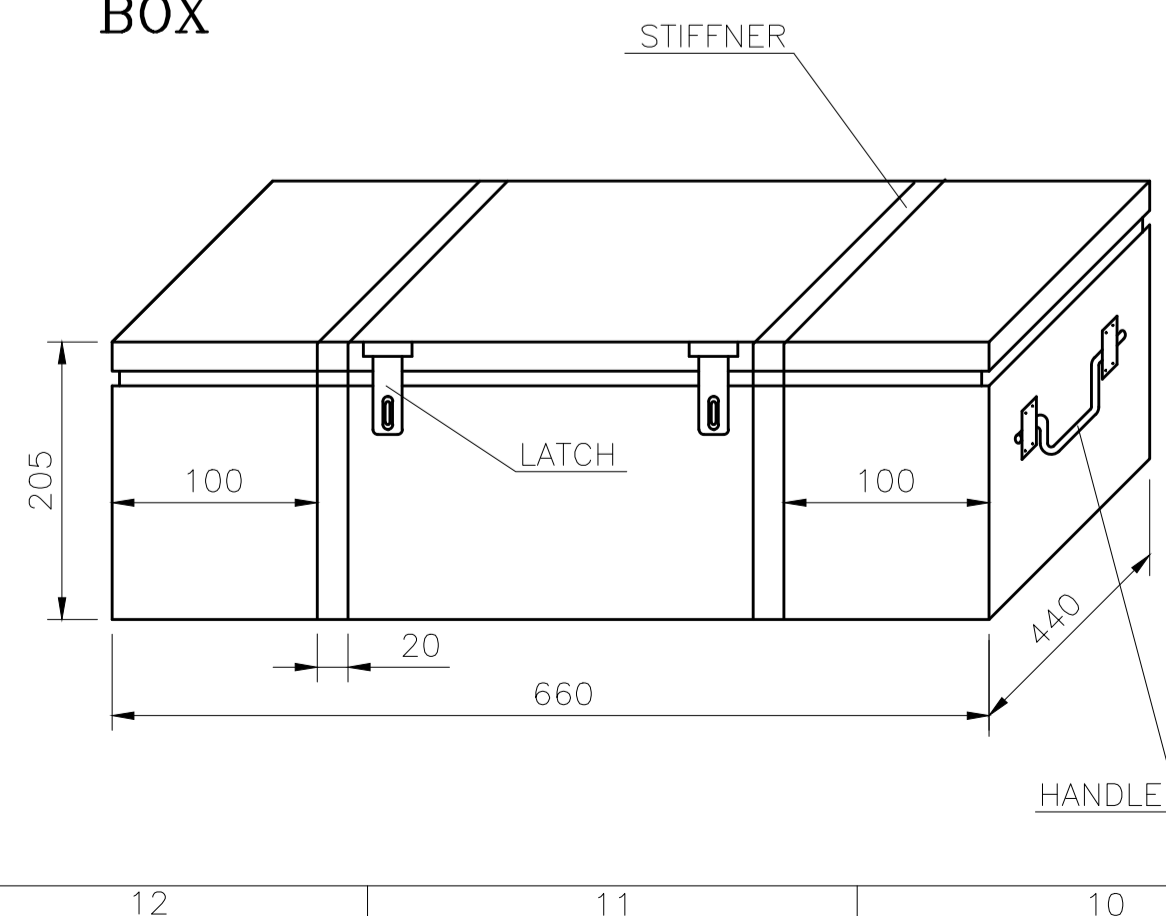

NOTES:

- COVER TO BE MADE FROM STEEL SHEET OF GAUGE 18 (~ 1.2 MM) AND BOX TO BE MADE FROM STEEL SHEET OF GAUGE 20 (~ 1.0 MM)
- ALL DIM. OF BOX ARE INTERNAL.
- TWO NOS STIFFNERS TO BE PROVIDED AROUND THE BOX AS SHOWN.
- HINGES ARE TO BE PROVIDED ON BACK SIDE TO OPEN THE COVER.
- FINAL PROTECTIVE FINISH - GREY PAINT, SHADE AS PER INDENTORS CHOICE.

GENERAL TOLERANCES LINEAR DIMENSIONS UP TO 18 ±0.15 > 18 TO 80 ±0.25 > 80 ±0.4	CASTING TOLERANCES LINEAR DIMENSIONS ±(0.5%+1MM) THICKNESS ±8% (MIN. ±0.5mm) ANGLES ±2°	FORGING TOLERANCES LINEAR DIMENSIONS UP TO 18 +0.5-0.3 > 18 TO 80 +1 -0.5 > 80 +2 -0.8	UNLESS OTHERWISE SPECIFIED ROUND EDGES 0.3 AND CHAMFER 0.3x45° SURFACE MARKED --- REQUIRE STOCK MATERIAL TO BE REMOVED AT ASSEMBLY
---	--	---	--

CBOM 07829062017-00		STATUS OF DRG		TYPE OF PRODUCT OR NAME OF CUSTOMER/PROJECT									
AGREED DEPT	NAME	SIGN	DATE	SRGM 76/62									
DABG-T	SUMIT	Sd/-	5.12.24										
GRADE OF UNTOL.DIM				BHARAT HEAVY ELECTRICALS LTD RANIPUR, HARDWAR									
M/CG.-C/M/F AA0230208				DRN	NAME	SIGN	DATE	NO. OF VAR					
WELDING-A/B/C/D AA0621104				CHD	HARENDRA	Sd/-	16.12.2024	---					
GAS CUTTING-T3'AA0621104				APPD	SK SINGH	Sd/-	16.12.2024	---					
REV	DATE	ALTERED	CHECKED	REV	DATE	ALTERED	CHECKED	DEPT DPE	SCALE	WEIGHT (KG)	REF. TO ASSY. DRG.	ITEM No.	NO. OF ITEMS
								CODE 4260	NTS	-	17829062013	1	---
TITLE : TOOL BOX-7 WITH PARTITIONS										CARD CODE	DRAWING NO. 17829218822		---
										---	SHEET No. -01 No. OF SHEETS -04		---

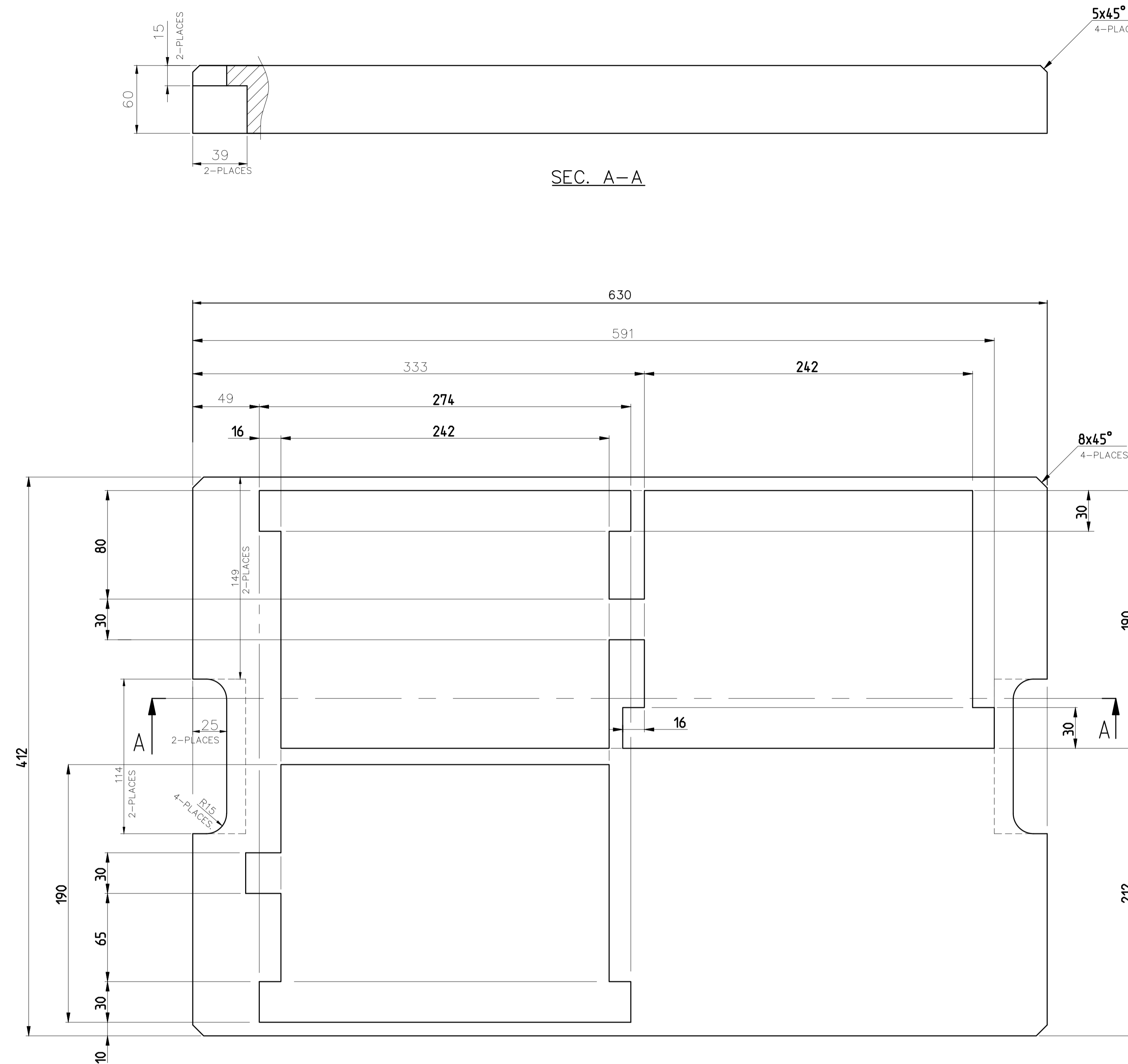

ALL SLOTS ARE 50 MM DEEP.

**TECHNICAL REQUIREMENTS**

1. MATERIAL- SHEESHAM WOOD WITH BASE PLATE OF PLYWOOD (THK-10MM).
2. TREATMENT- LACQUERING ALL OVER.
3. ALL INNER DIMENSIONS OF LAYOUT ARE FOR REFERENCE ONLY AND MAY BE CHANGED DEPENDING ON TOOL PLACEMENT AND SUPPLIER HAS TO MODIFY SUITABLY AT BHEL HARIDWAR-WORKS.

GENERAL TOLERANCES LINEAR DIMENSIONS UP TO 18 ±0.15 > 18 TO 80 ±0.25 > 80 ±0.4 ANGLES ±30'	CASTING TOLERANCES LINEAR DIMENSIONS ±(0.5%+1MM) THICKNESS ±0.2 (MIN. ±0.5mm) ANGLES ±2'	FORGING TOLERANCES LINEAR DIMENSIONS UP TO 18 ±0.5-0.3 > 18 TO 80 ±1 -0.5 > 80 ±2 -0.8 ANGLES ±1'	UNLESS OTHERWISE SPECIFIED ROUND EDGES 0.3 AND CHAMFER 0.3x45° SURFACE MARKED --- REQUIRE STOCK MATERIAL TO BE REMOVED AT ASSEMBLY
--	---	---	--

CBOM	07829062017-00	STATUS OF DRG	
AGREED	NAME	SIGN	DATE
DABG-T	SUMIT	Sd/-	5.12.24

TYPE OF PRODUCT OR NAME OF CUSTOMER/PROJECT	SRGM 76/62
---	------------

GRADE OF UNTOL.DIM	M/CG.-C/M/F AA0230208
WELDING-#/B/φ/∅	AA0621104
GAS CUTTING	T3'AA0621104

NAME	SIGN	DATE	NO. OF VAR
DRN SANDEEP	Sd/-	16.12.2024	---
CHD HARENDRA	Sd/-	16.12.2024	---
APPD SK SINGH	Sd/-	16.12.2024	---

REV	DATE	ALTERED	REV	DATE	ALTERED
		CHECKED			CHECKED

DEPT DPE	SCALE	WEIGHT (KG)	REF. TO ASSY. DRG.	ITEM No.	NO. OF ITEMS
CODE 4260	NTS	-	17829062013	1	---

TITLE : TOOL BOX-7 WITH PARTITIONS	CARD CODE	DRAWING NO.	NO. OF SHEETS
		17829218822	-04

PROPRIETARY DATA OF DTD MELARA SPA  
 LIMITED RIGHTS OF TECHNICAL DATA  
 THE TECHNICAL DATA SET FORTH HEREIN IS SUBJECT TO THE TERMS AND CONDITIONS OF THE LICENSE AGREEMENT BETWEEN DTD MELARA SPA AND BHARAT HEAVY ELECTRICALS LTDZ  
 THE TECHNICAL DATA CONTAINED HEREIN IS RESTRICTED AS TO USE, REPLICATION OR DISCLOSURE AS PER TERMS AND CONDITIONS OF THE LICENSE AGREEMENT  
 INVENTORY NO. SIGN. & DATE REF. DRG. NO. 157692231-00

PROPRIETARY DATA OF DTD MELARA SPA  
 LIMITED RIGHTS OF TECHNICAL DATA  
 THE TECHNICAL DATA SET FORTH HEREIN IS RESTRICTED AS TO USE, REPRODUCTION OR DISCLOSURE AS PER TERMS AND CONDITIONS OF THE LICENSE AGREEMENT BETWEEN DTD MELARA SPA AND BHARAT HEAVY ELECTRICALS LTDZ  
 THE TECHNICAL DATA CONTAINED HEREIN IS RESTRICTED AS TO USE, REPRODUCTION OR DISCLOSURE AS PER TERMS AND CONDITIONS OF THE LICENSE AGREEMENT

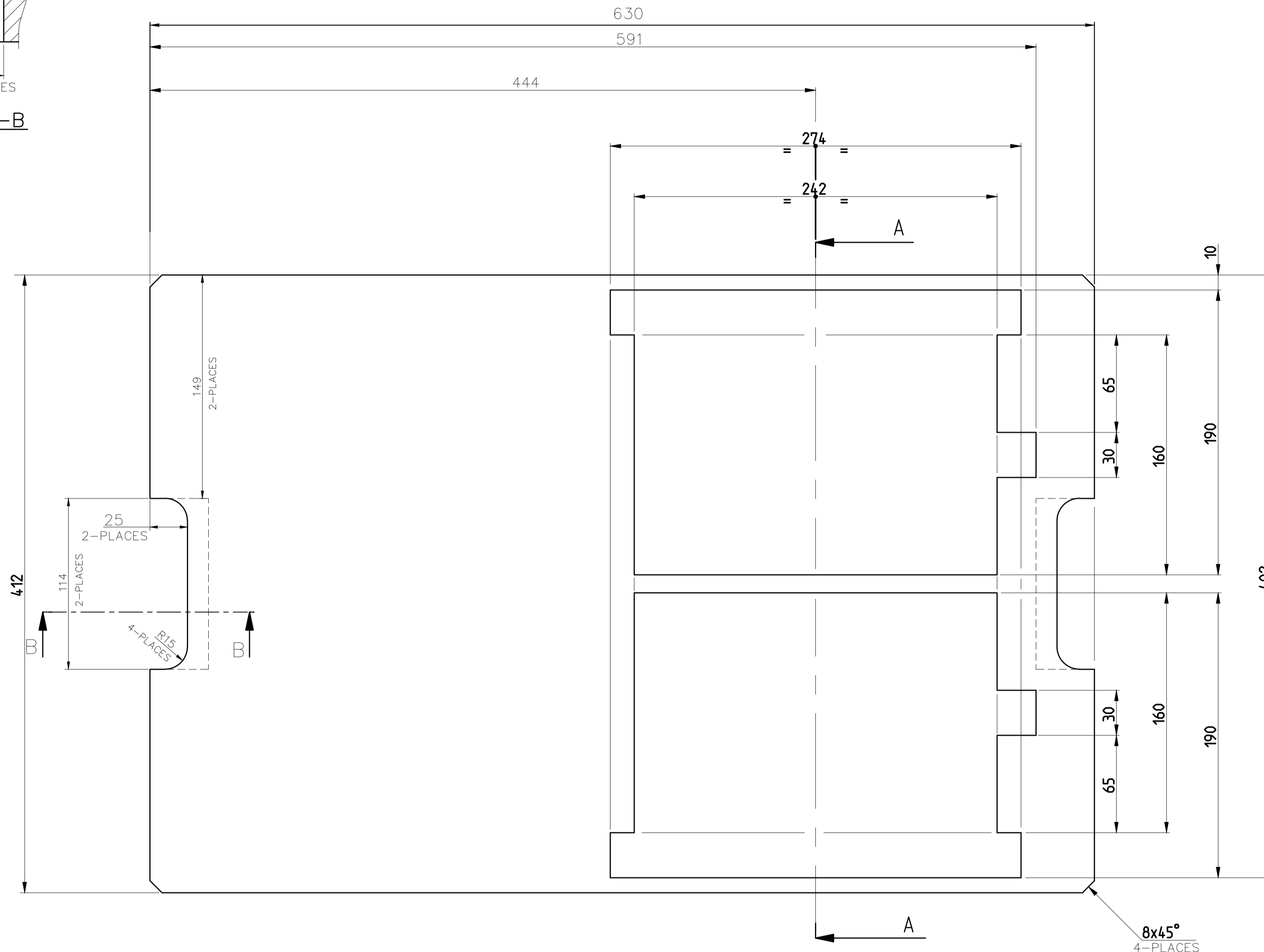
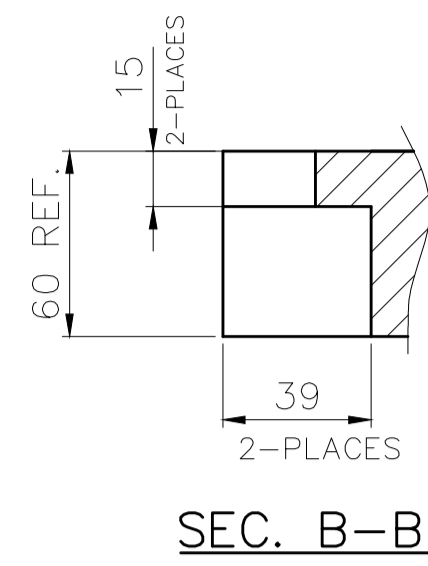
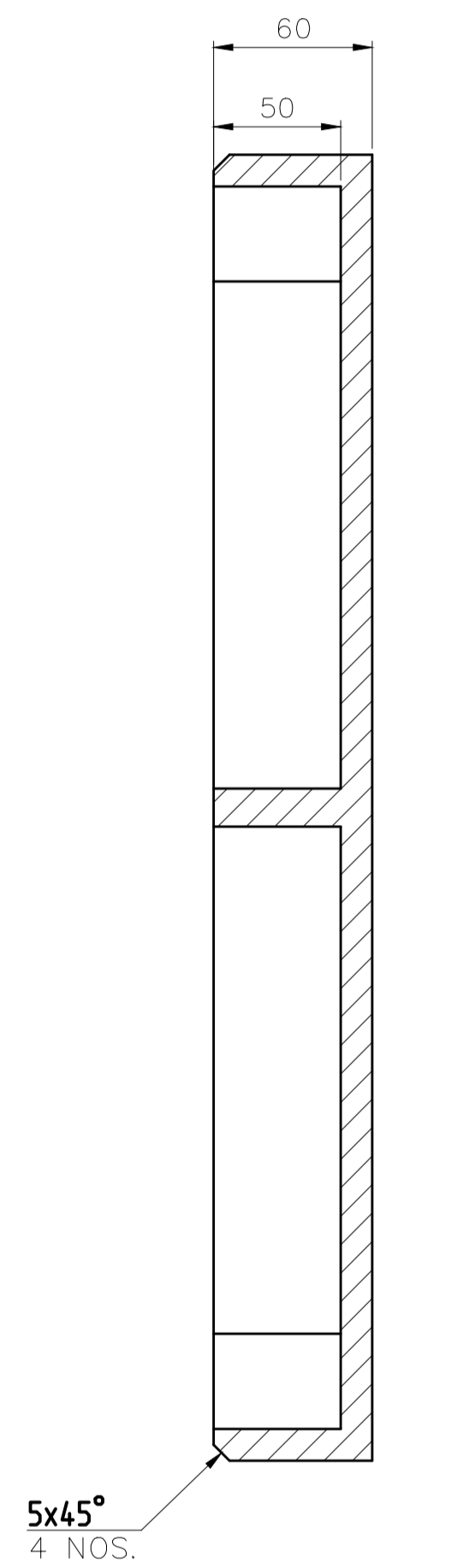

**TECHNICAL REQUIREMENTS**

1. MATERIAL- SHEESHAM WOOD WITH BASE PLATE OF PLYWOOD (THK-10MM).
2. TREATMENT- LACQUERING ALL OVER.
3. ALL INNER DIMENSIONS OF LAYOUT ARE FOR REFERENCE ONLY AND MAY BE CHANGED DEPENDING ON TOOL PLACEMENT AND SUPPLIER HAS TO MODIFY SUITABLY AT BHEL HARIDWAR-WORKS.

GENERAL TOLERANCES LINEAR DIMENSIONS UP TO 18 ±0.15 > 18 TO 80 ±0.25 > 80 ±0.4 ANGLES ±30°	CASTING TOLERANCES LINEAR DIMENSIONS ±(0.5%+1MM) THICKNESS ±0.4 (MIN. ±0.5mm) ANGLES ±2°	FORGING TOLERANCES LINEAR DIMENSIONS UP TO 18 ±0.5-0.3 > 18 TO 80 ±1 -0.5 > 80 ±2 -0.8 ANGLES ±1°	UNLESS OTHERWISE SPECIFIED ROUND EDGES 0.3 AND CHAMFER 0.3x45° SURFACE MARKED --- REQUIRE STOCK MATERIAL TO BE REMOVED AT ASSEMBLY
--	---	---	--

CBOM	07829062017-00	STATUS OF DRG	
AGREED	NAME	SIGN	DATE
DABG-T	SUMIT	Sd/-	5.12.24

TYPE OF PRODUCT	SRGM 76/62
OR	
NAME OF CUSTOMER/PROJECT	

GRADE OF UNTOL.DIM	M/CG.-C/M/F AA0230208				
WELDING-#/B/φ/∅	AA0621104				
GAS CUTTING	T3'AA0621104				
REV	DATE	ALTERED	REV	DATE	ALTERED
		CHECKED			CHECKED

NAME	SIGN	DATE	NO. OF VAR
DRN SANDEEP	Sd/-	16.12.2024	
CHD HARENDRA	Sd/-	16.12.2024	
APPD SK SINGH	Sd/-	16.12.2024	
DEPT DPE	SCALE NTS	WEIGHT (KG)	REF. TO ASSY. DRG.
CODE 4260			17829062013
TITLE : TOOL BOX-7 WITH PARTITIONS	CARD CODE	ITEM No.	NO. OF ITEMS
		1	---
		DRAWING NO. 17829218822	
		SHEET No. -03	No. OF SHEETS -04



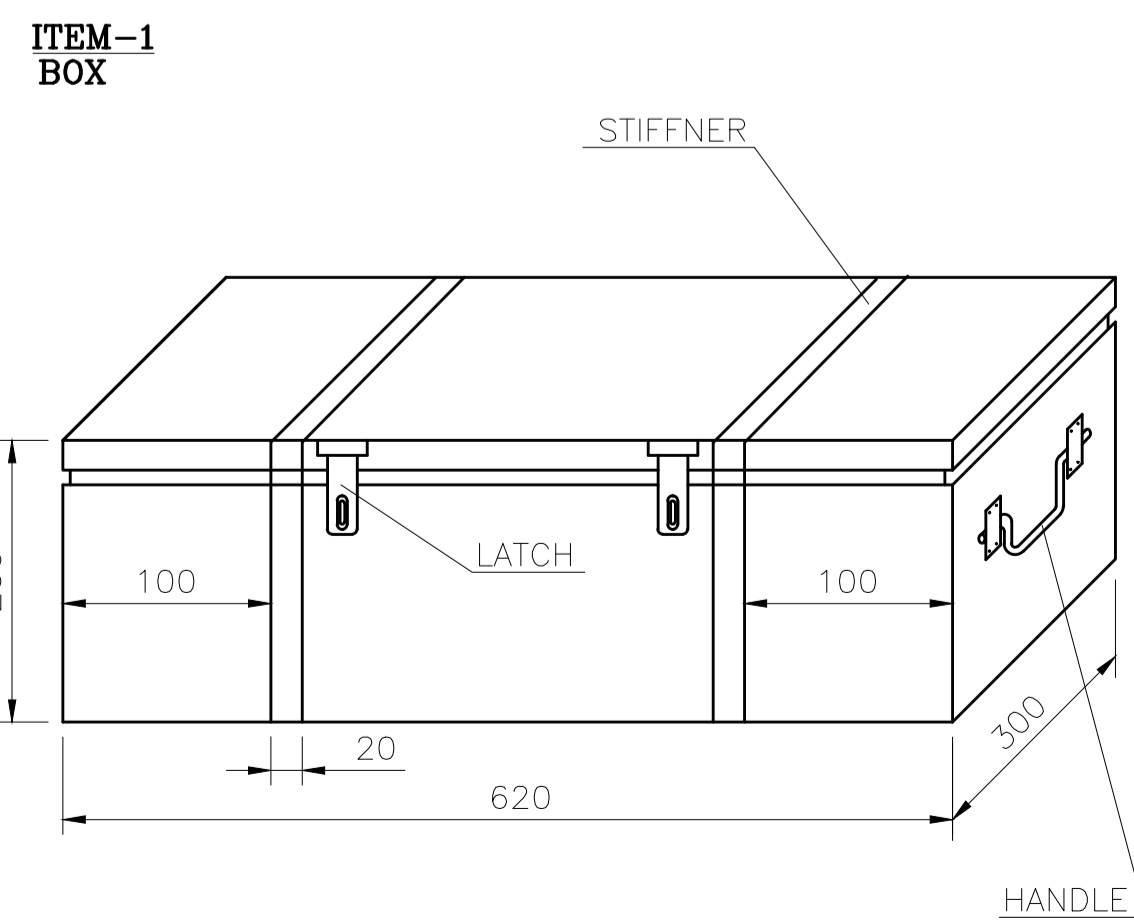
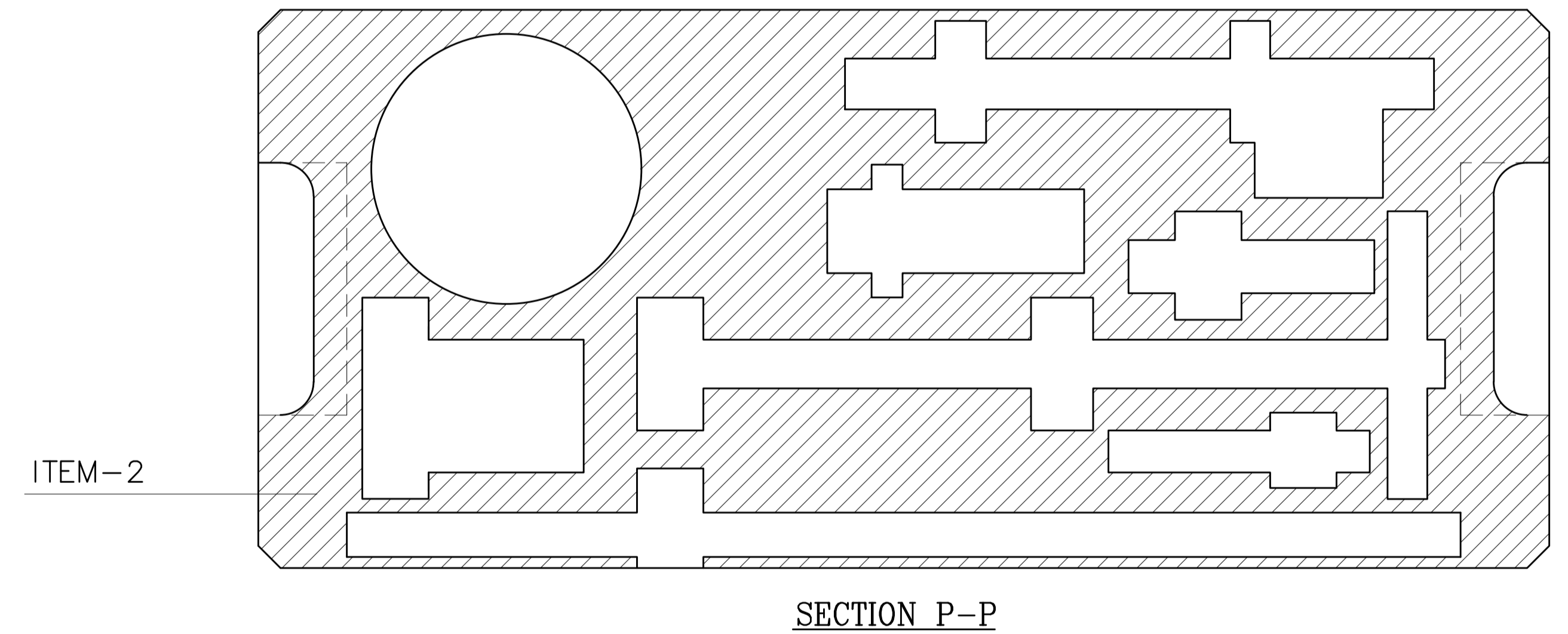
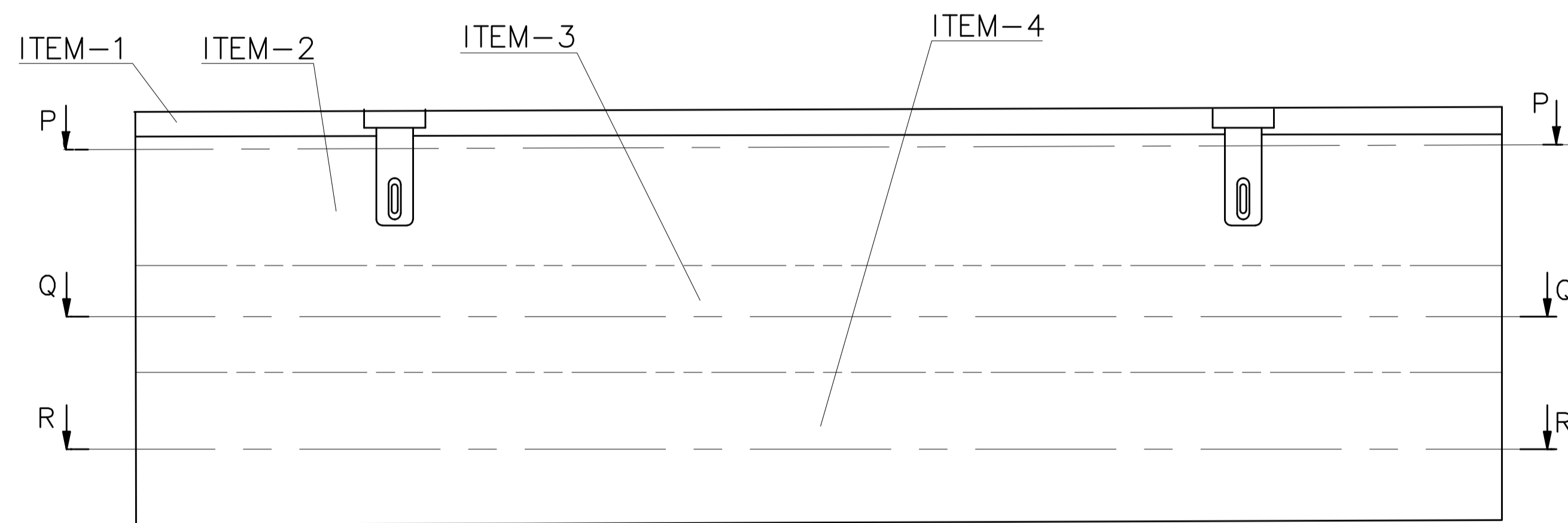
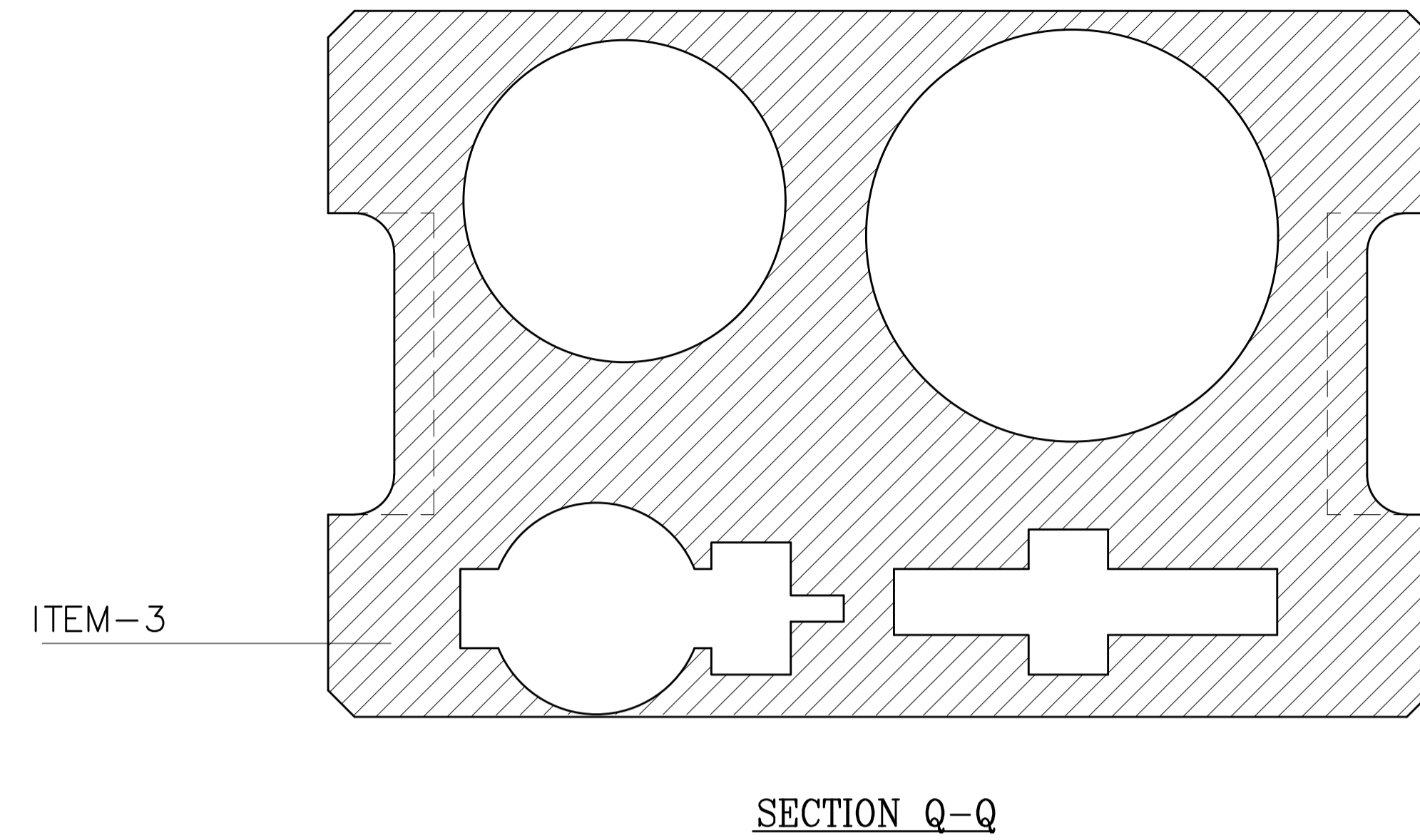
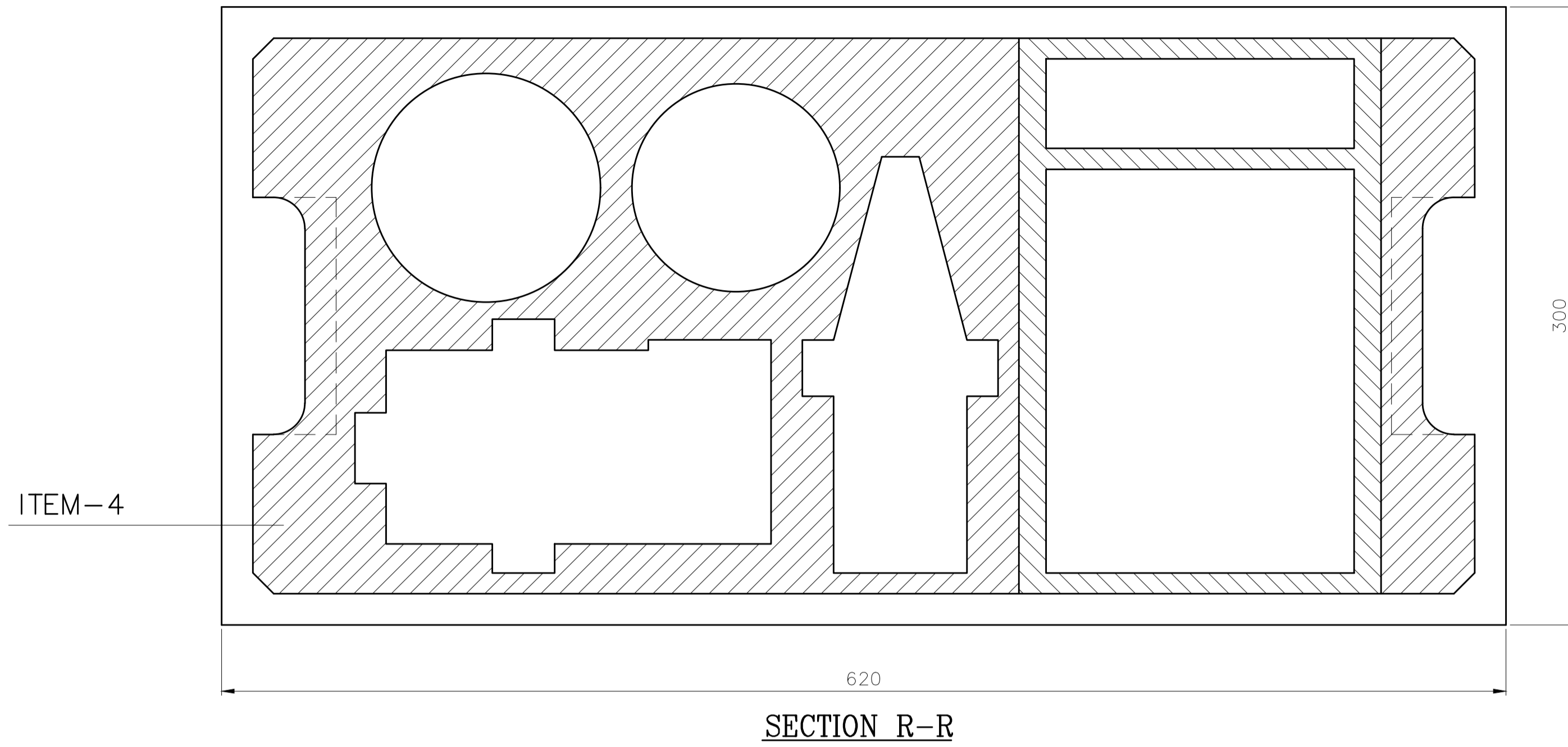

- NOTES:**
- COVER TO BE MADE FROM STEEL SHEET OF GAUGE 18 (~ 1.2 MM) AND BOX TO BE MADE FROM STEEL SHEET OF GAUGE 20 (~ 1.0 MM)
  - ALL DIM. OF BOX ARE INTERNAL.
  - TWO NOS STIFFNERS TO BE PROVIDED AROUND THE BOX AS SHOWN.
  - HINGES ARE TO BE PROVIDED ON BACK SIDE TO OPEN THE COVER.
  - FINAL PROTECTIVE FINISH - GREY PAINT, SHADE AS PER INDENTORS CHOICE.

GENERAL TOLERANCES LINEAR DIMENSIONS UP TO 18 ±0.15 > 18 TO 80 ±0.25 > 80 ±0.4 ANGLES ±30'	CASTING TOLERANCES LINEAR DIMENSIONS ±(0.5%+1MM) THICKNESS ±0.5 (MIN. ±0.5mm) ANGLES ±2'	FORGING TOLERANCES LINEAR DIMENSIONS UP TO 18 ±0.5-0.3 > 18 TO 80 ±1-0.5 > 80 ±2 -0.8 ANGLES ±1'	UNLESS OTHERWISE SPECIFIED ROUND EDGES 0.3 AND CHAMFER 0.3x45° SURFACE MARKED --- REQUIRE STOCK MATERIAL TO BE REMOVED AT ASSEMBLY
--	---	--	--

CBOM 07829062017-00 STATUS OF DRG				TYPE OF PRODUCT OR NAME OF CUSTOMER/PROJECT							
AGREED	NAME	SIGN	DATE	SRGM 76/62							
DABG-T	SUMIT	Sd/-	5.12.24								
GRADE OF UNTOL.DIM				NAME							
M/CG.-C/M/F AA0230208				DRN SANDEEP Sd/- 16.12.2024							
WELDING-A/B/C/D AA0621104				CHD HARENDRA Sd/- 16.12.2024							
GAS CUTTING T3'AA0621104				APPD SK SINGH Sd/- 16.12.2024							
REV	DATE	ALTERED CHECKED	REV	DATE	ALTERED CHECKED	DEPT DPE	SCALE	WEIGHT (KG)	REF. TO ASSY. DRG.	ITEM No.	NO. OF ITEMS
						CODE 4260	NTS	-	07829218015	1	---
TITLE : TOOL BOX-5 WITH PARTITIONS				DRAWING NO. 17829218816				CARD CODE		SHEET No. -01/No. OF SHEETS -04	

PROPRIETARY DATA OF DTD MELARA SPA  
 LIMITED RIGHTS OF TECHNICAL DATA  
 THE TECHNICAL DATA SET FORTH HEREIN IS SUBJECT TO THE TERMS AND CONDITIONS OF THE LICENSE AGREEMENT BETWEEN DTD MELARA SPA AND BHARAT HEAVY ELECTRICALS LTDZ  
 THE TECHNICAL DATA CONTAINED HEREIN IS RESTRICTED AS TO USE, REPLICATION OR DISCLOSURE AS PER TERMS AND CONDITIONS OF THE LICENSE AGREEMENT  
 INVENTORY NO. SIGN. & DATE REF. DRG. NO. 157692816-01

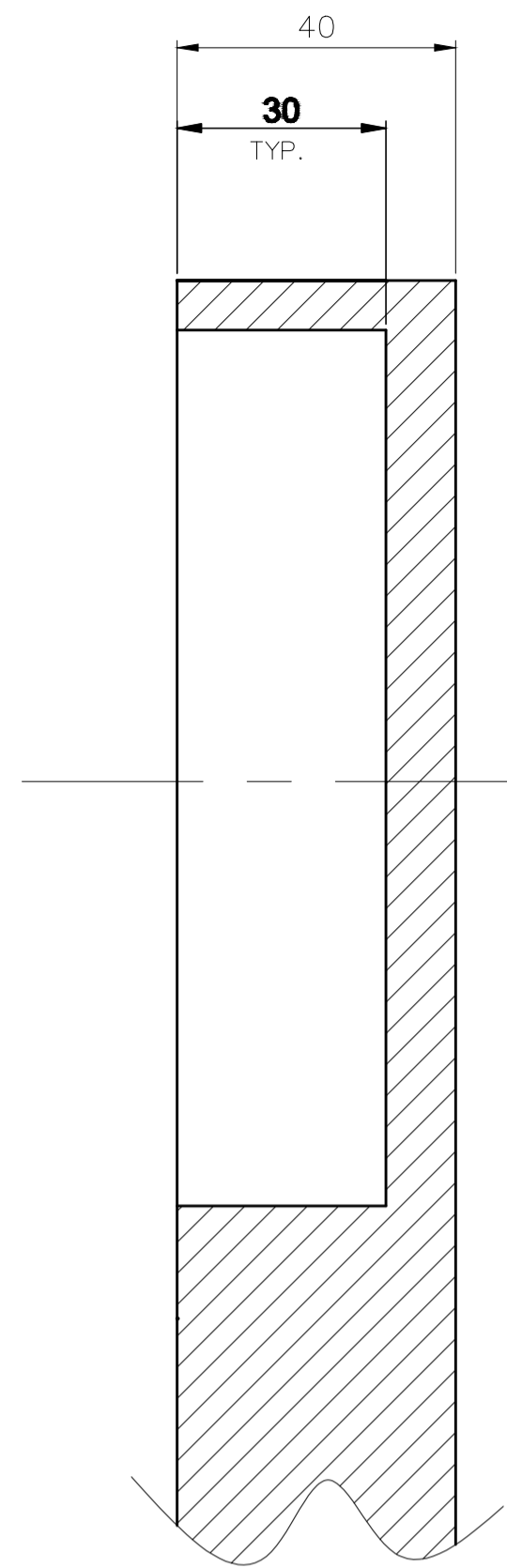

SECTION A-A

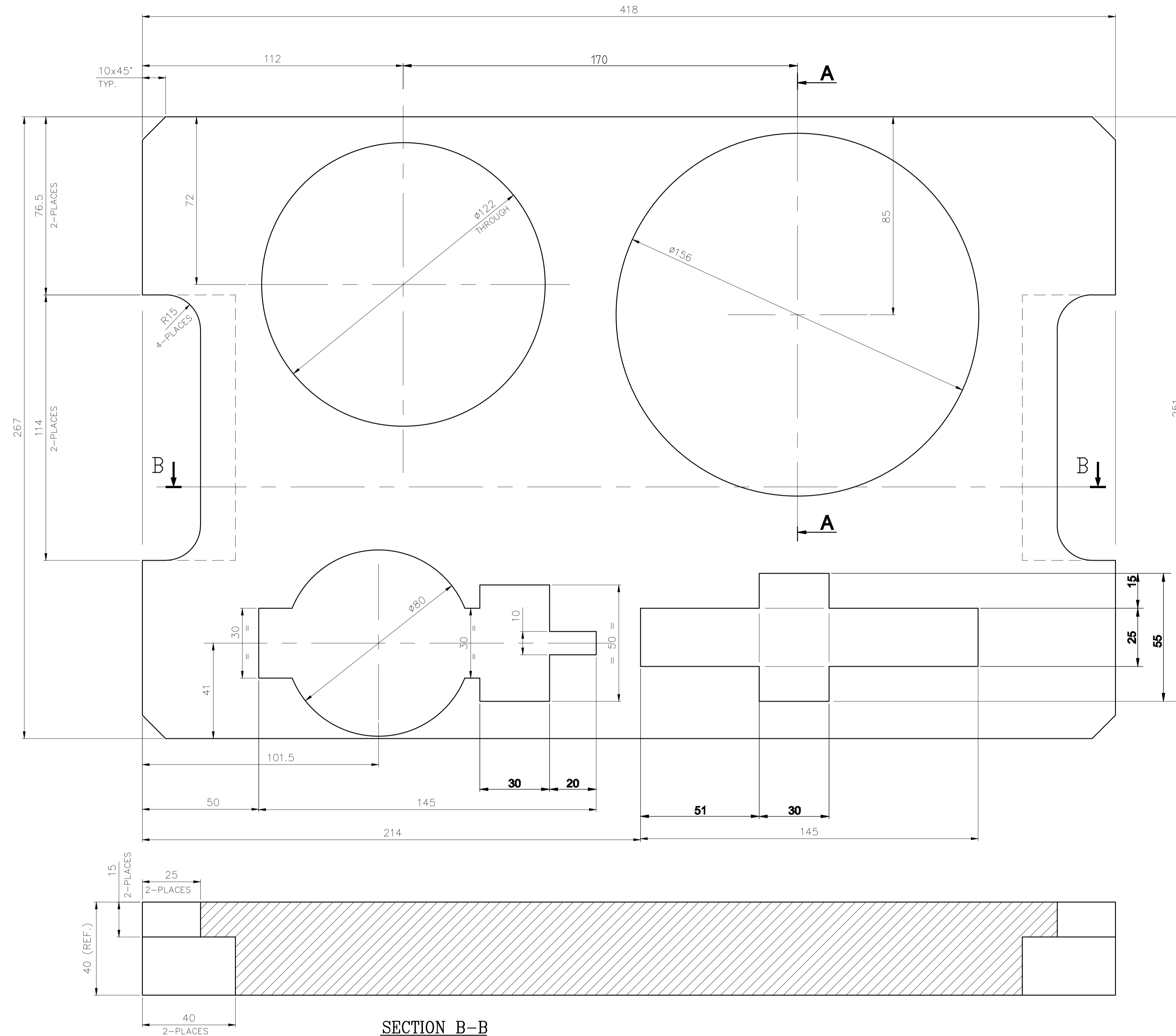

SECTION B-B

**TECHNICAL REQUIREMENTS**

1. MATERIAL- SHEESHAM WOOD WITH BASE PLATE OF PLYWOOD (THK-10MM).
2. TREATMENT- LACQUERING ALL OVER.
3. ALL INNER DIMENSIONS OF LAYOUT ARE FOR REFERENCE ONLY AND MAY BE CHANGED DEPENDING ON TOOL PLACEMENT AND SUPPLIER HAS TO MODIFY SUITABLY AT BHEL HARIDWAR-WORKS.

GENERAL TOLERANCES LINEAR DIMENSIONS UP TO 18 ±0.15 > 18 TO 80 ±0.25 > 80 ±0.4 ANGLES ±30'	CASTING TOLERANCES LINEAR DIMENSIONS ±(0.5%+1MM) THICKNESS ±0.4 (MIN. ±0.5mm) ANGLES ±2'	FORGING TOLERANCES LINEAR DIMENSIONS UP TO 18 ±0.5-0.3 > 18 TO 80 ±1 -0.5 > 80 ±2 -0.8 ANGLES ±1'	UNLESS OTHERWISE SPECIFIED ROUND EDGES 0.3 AND CHAMFER 0.3x45° SURFACE MARKED --- REQUIRE STOCK MATERIAL TO BE REMOVED AT ASSEMBLY
--	---	---	--

CBOM 07829062017-00	STATUS OF DRG U
AGREED DEPT	NAME SUMIT
SIGN Sd/-	DATE 5.12.24

TYPE OF PRODUCT OR NAME OF CUSTOMER/PROJECT	SRGM 76/62
---	------------

GRADE OF UNTOL.DIM M/CG.-C/M/F AA0230208
WELDING-#/B/φ/∅ AA0621104
GAS CUTTING-T3-AA0621104

NAME SANDEEP	SIGN Sd/-	DATE 16.12.2024	NO. OF VAR ---
NAME HARENDRA	SIGN Sd/-	DATE 16.12.2024	
NAME SK SINGH	SIGN Sd/-	DATE 16.12.2024	

REV	DATE	ALTERED CHECKED
-----	------	--------------------

REV	DATE	ALTERED CHECKED
-----	------	--------------------

DEPT DPE CODE 4260	SCALE NTS	WEIGHT (KG) -	REF. TO ASSY. DRG. 07829218015	ITEM No. 1	NO. OF ITEMS ---
-----------------------	--------------	------------------	-----------------------------------	------------------	------------------------

TITLE : TOOL BOX-5 WITH PARTITIONS	CARD CODE ---	DRAWING NO. 17829218816	NO. OF SHEETS -04
------------------------------------	------------------	----------------------------	----------------------

17829218816 DRG. NO.

12.5 ALL OVER UNLESS OTHERWISE STATED

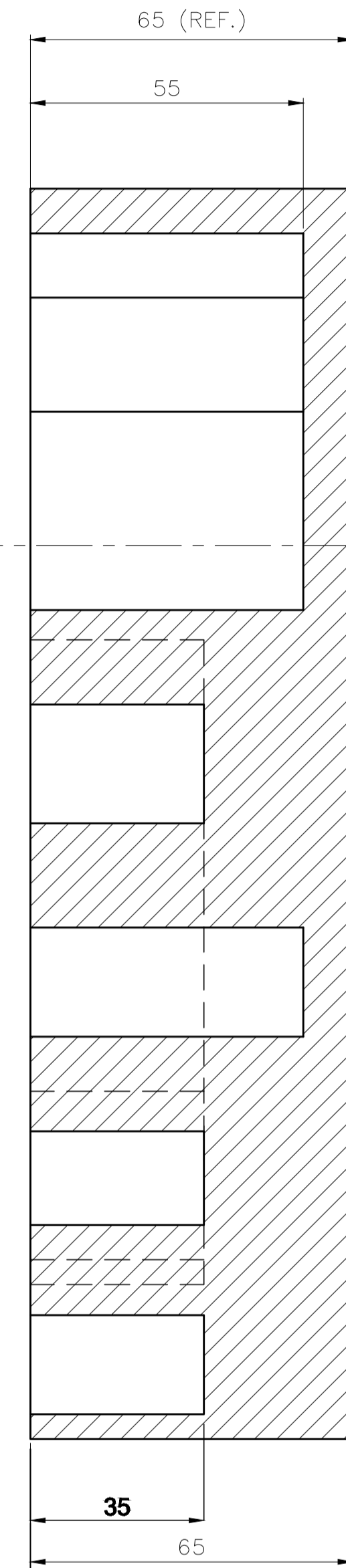

SECTION C-C

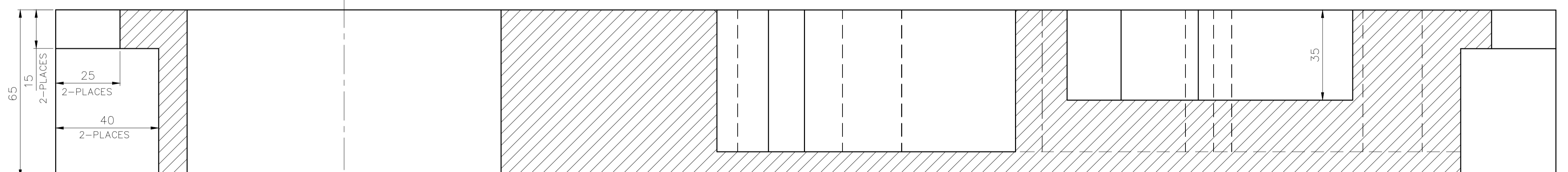
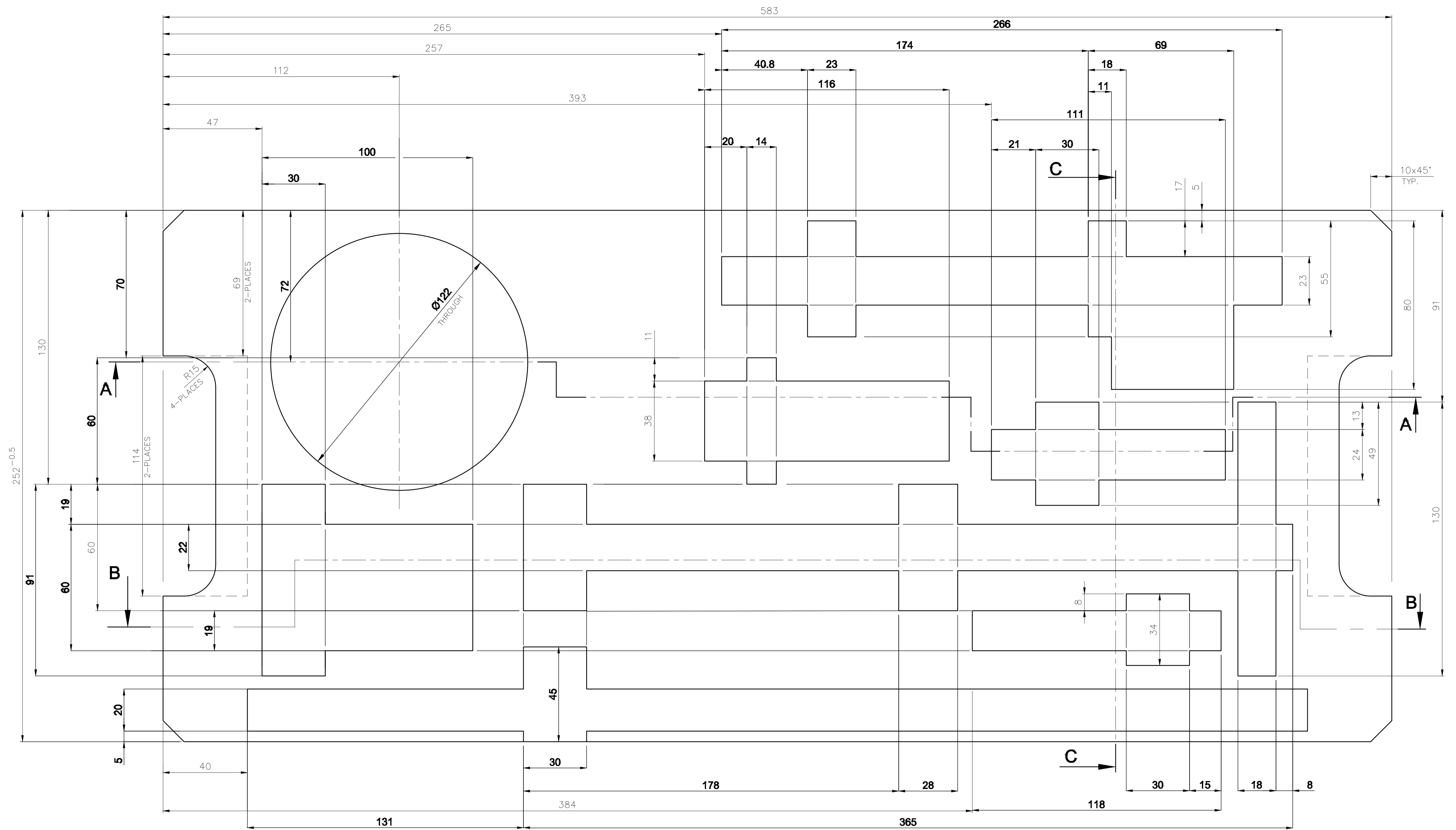

SECTION A-A

TECHNICAL REQUIREMENTS

1. MATERIAL- SHEESHAM WOOD WITH BASE PLATE OF PLYWOOD (THK-10MM).
2. TREATMENT- LACQUERING ALL OVER.
3. ALL INNER DIMENSIONS OF LAYOUT ARE FOR REFERENCE ONLY AND MAY BE CHANGED DEPENDING ON TOOL PLACEMENT AND SUPPLIER HAS TO MODIFY SUITABLY AT BHEL HARIDWAR-WORKS.

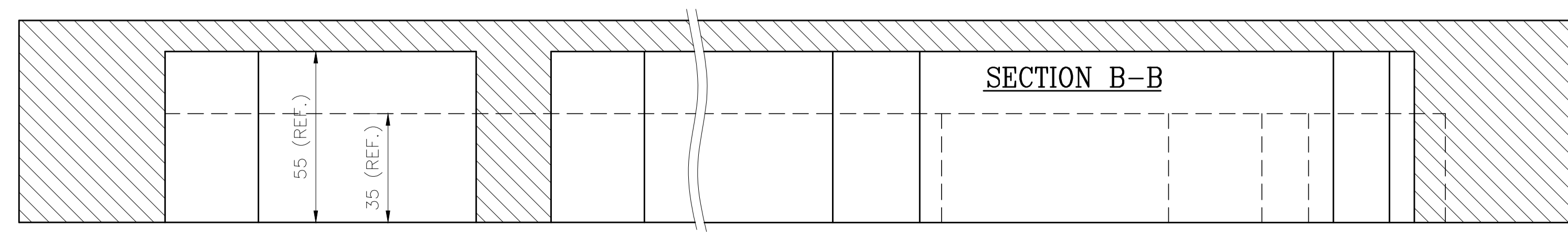

SECTION B-B

GENERAL TOLERANCES LINEAR DIMENSIONS UP TO 18 ±0.15 > 18 TO 80 ±0.25 > 80 ±0.4 ANGLES ±30'	CASTING TOLERANCES LINEAR DIMENSIONS ±(0.5%+1MM) THICKNESS ±0.2 (MIN. ±0.5mm) ANGLES ±2'	FORGING TOLERANCES LINEAR DIMENSIONS UP TO 18 ±0.5-0.3 > 18 TO 80 ±1-0.5 > 80 ±2 -0.8 ANGLES ±1'	UNLESS OTHERWISE SPECIFIED ROUND EDGES 0.3 AND CHAMFER 0.3x45° SURFACE MARKED --- REQUIRE STOCK MATERIAL TO BE REMOVED AT ASSEMBLY
--	---	--	---

CBOM 07829062017-00		STATUS OF DRG	
AGRD	NAME	SIGN	DATE
DABG-T	SUMIT	Sd/-	5.12.24

TYPE OF PRODUCT OR NAME OF CUSTOMER/PROJECT		SRGM 76/62	
DRN	NAME	SIGN	DATE
CHD	SANDEEP		16.12.2024
APPD	HARENDRA		16.12.2024
	SK SINGH		16.12.2024

GRADE OF UNTOL.DIM	
M/CG.-C/M/F	AA0230208
WELDING-#/B/C/D	AA0621104
GAS CUTTING	T3'AA0621104
REV	DATE
	ALTERED
	CHECKED

REV	DATE	ALTERED
		CHECKED

DEPT DPE	SCALE	WEIGHT (KG)	REF. TO ASSY. DRG.	ITEM No.	NO. OF ITEMS
CODE 4260	NTS	-	07829218015	1	---
TITLE : TOOL BOX-5 WITH PARTITIONS		CARD CODE	DRAWING NO. 17829218816		
			SHEET No. -03/No. OF SHEETS -04		

INVENTORY NO. SIGN. & DATE REF. DRG. NO. 157692136-01

PROPRIETARY DATA OF DTD MELARA SPA  
 LIMITED RIGHTS OF TECHNICAL DATA  
 THE TECHNICAL DATA SET FORTH HEREIN IS SUBJECT TO THE TERMS AND CONDITIONS OF THE LICENSE AGREEMENT BETWEEN DTD MELARA SPA AND BHARAT HEAVY ELECTRICALS LTDZ  
 THE TECHNICAL DATA CONTAINED HEREIN IS RESTRICTED AS TO USE, REPLICATION OR DISCLOSURE AS PER TERMS AND CONDITIONS OF THE LICENSE AGREEMENT

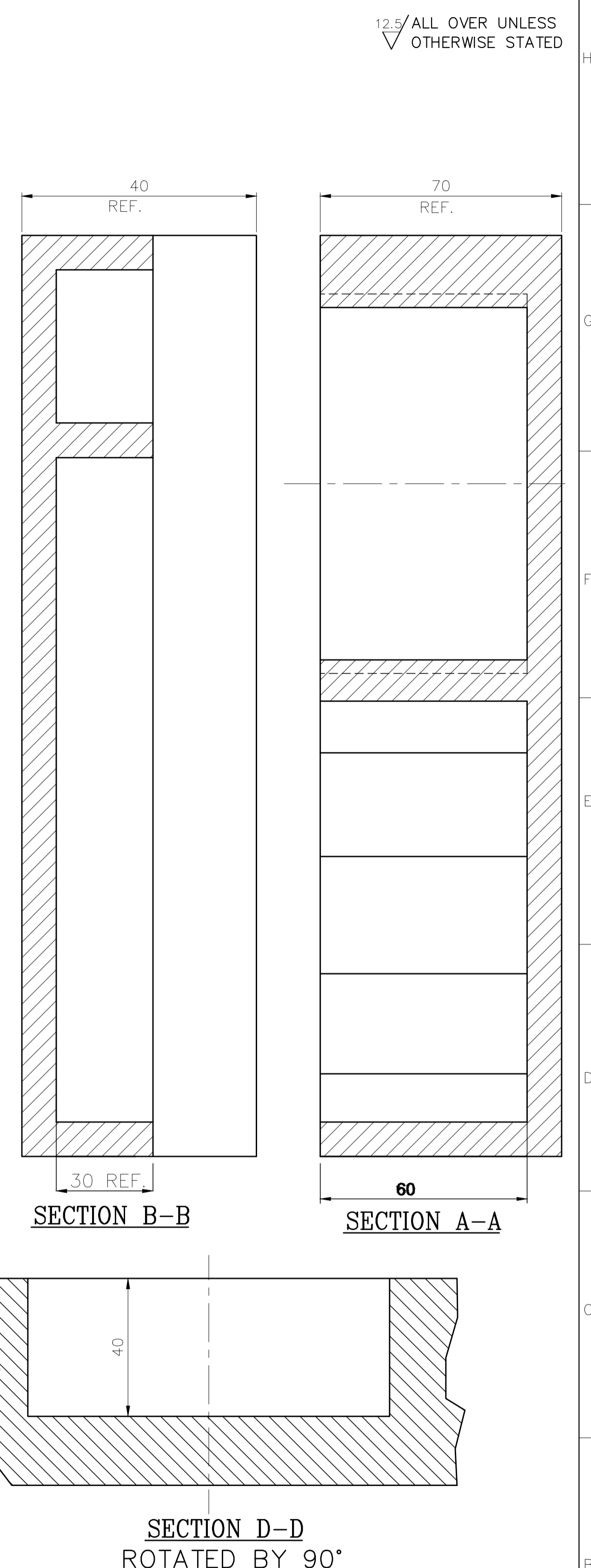
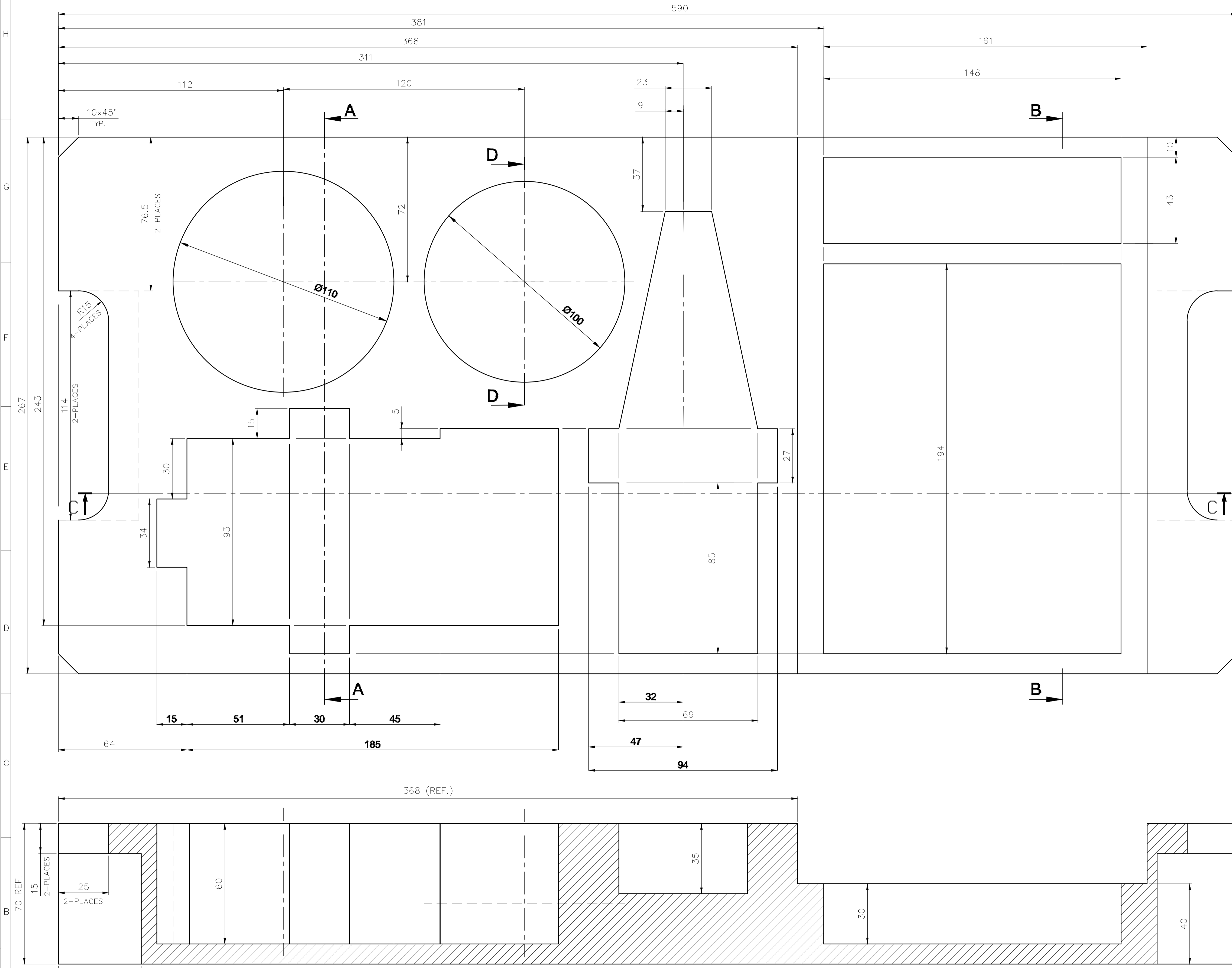

12.5 ALL OVER UNLESS OTHERWISE STATED

**TECHNICAL REQUIREMENTS**

- MATERIAL- SHEESHAM WOOD WITH BASE PLATE OF PLYWOOD (THK-10MM).
- TREATMENT- LACQUERING ALL OVER.
- ALL INNER DIMENSIONS OF LAYOUT ARE FOR REFERENCE ONLY AND MAY BE CHANGED DEPENDING ON TOOL PLACEMENT AND SUPPLIER HAS TO MODIFY SUITABLY AT BHEL HARIDWAR-WORKS.

**SECTION C-C**

CBOM	07829062017-00	STATUS OF DRG	
AGRD	NAME	SIGN	DATE
DABG-T	SUMIT	Sd/-	5.12.24

GRADE OF UNTOL.DIM	
M/CG.-C/M/F	AA0230208
WELDING-#B/C/D	AA0621104
GAS CUTTING	T3'AA0621104

GENERAL TOLERANCES LINEAR DIMENSIONS UP TO 18 ±0.15 > 18 TO 80 ±0.25 > 80 ±0.4	CASTING TOLERANCES LINEAR DIMENSIONS ±(0.5%+1MM) THICKNESS ±0.2 (MIN. ±0.5mm) ANGLES ±2°	FORGING TOLERANCES LINEAR DIMENSIONS UP TO 18 ±0.5-0.3 > 18 TO 80 ±1-0.5 > 80 ±2 -0.8	UNLESS OTHERWISE SPECIFIED ROUND EDGES 0.3 AND CHAMFER 0.3x45° SURFACE MARKED --- REQUIRE STOCK MATERIAL TO BE REMOVED AT ASSEMBLY
---	---	--	--

TYPE OF PRODUCT OR NAME OF CUSTOMER/PROJECT		<b>SRGM 76/62</b>	
DEPT	DPE	SCALE	WEIGHT (KG)
CODE 4260		NTS	-
TITLE	CARD CODE	REF. TO ASSY. DRG.	ITEM No.
<b>TOOL BOX-5 WITH PARTITIONS</b>		07829218015	1
DRAWING NO. 17829218816		SHEET No. -04/No. OF SHEETS -04	

INVENTORY NO. SIGN. & DATE REF. DRG. NO. 157692134-01

## COMMERCIAL & QUALITY CHECKLIST

SL. NO.	TERMS & CONDITION	VENDOR's CONFIRMATION /REMARKS / REPLY
<b>TENDER DETAILS</b>		
1	COMPANY / FIRM NAME OF BIDDER	
2	GEM BID NO	
<b>QUALITY REQUIREMENTS</b>		
3	VENDOR TO CONFIRM TO PROVIDE TEST CERTIFICATES AS PER MANUFACTURER'S STANDARD PRACTICE INCLUDING DOCUMENTS CONFORMING TO ENQUIRY MODEL/PART NO. ALONG WITH THE MATERIAL.	
4	VENDOR TO CONFIRM TO PROVIDE CERTIFICATE OF CONFORMANCE.	
5	VENDOR TO CONFIRM TO PROVIDE IDENTIFICATION OF ALL ITEMS AND SAME SHOULD BE MENTIONED IN IDENTIFICATION REPORTS.	
<b>COMMERICAL REMARKS</b>		
6	VENDOR TO SUBMIT <b>MAKE IN INDIA CERTIFICATE</b> AS PER ATTACHED FORMAT ONLY	
7	<b>BREACH OF CONTRACT CLAUSE:</b> VENDOR TO AGREE AS PER CLAUSE NO 14 OF ATC	
8	<b>CONFLICT OF INTEREST</b> AMONG BIDDERS/ AGENTS: VENDOR TO AGREE AS PER CLAUSE NO 32 OF ATC	
9	ACTION AGAINST BIDDERS / VENDOR / SUPPLIER / CONTRACTOR IN CASE OF DEFAULT SHALL BE AS PER CLAUSE 27 OF ATC	
10	Vendor to confirm regarding <b>Declaration regarding compliance to Restrictions under Rule 144 (xi) of GFR 2017</b> as below: I have read the clause regarding restrictions on procurement from a bidder of a country which shares a land border with India. I certify that <b>OUR COMPANY / FIRM</b> is not from such a country/ has been registered with the Competent Authority (attach valid registration by the Competent Authority, i.e., the Registration Committee constituted by the Dept. for Promotion of Industry and Internal Trade (DPIIT).	
11	<b>Vendor to confirm the following:</b> We hereby confirm that we have not changed/ modified/materially altered any of the tender documents as downloaded from the website/ issued by BHEL and in case of such observance at any stage, it shall be treated as null and void.	
12	<b>Vendor to confirm the following:</b> We confirm our unqualified acceptance to all Terms and Conditions, unqualified compliance to Tender Conditions	
13	REST TERMS AND CONDITIONS SHALL BE as per GEM (Latest Version- applicable at the time of issuance of enquiry) and Enquiry ATC (ADDITIONAL TERMS & CONDITIONS)	

**DECLARATION REGARDING MINIMUM LOCAL CONTENT IN LINE WITH  
REVISED PUBLIC PROCUREMENT (PREFERENCE TO MAKE IN INDIA), Order 2017" Dt. 19.07.2024  
issued vide Order No. P-45021/2/2017-PP(BE-II)-Part(4)Vol.II AND SUBSEQUENT ORDER(S)  
(To be typed and submitted in the Letter Head of the Entity/Firm providing certificate as applicable)**

---

To,  
Manager  
PPX-DABG  
BHEL-HEEP, HARIDWAR

Dear Sir,

**Sub:** Declaration reg. minimum local content in line with Public Procurement (Preference to Make in India), Order 2017" Dt. 19.07.2024 issued vide Order No. P-45021/2/2017-PP(BE-II)-Part(4) Vol.II and subsequent order(s).

**Ref:** 1) GeM Bid Specification No: .....  
2) All other pertinent issues till date

We hereby certify that the items/works/services offered by..... (*specify the name of the organization here*) has a local content of \_\_\_\_\_ % and this meets the local content requirement for '**Class-I local supplier**' / '**Class II local supplier**' (*Strike out whichever is not applicable*) as defined in Public Procurement (Preference to Make in India), Order 2017-Revision dated 04.06.2020 issued by DPIIT and subsequent order(s).

The details of the location(s) at which the local value addition is made are as follows:

- |          |              |
|----------|--------------|
| 1. _____ | 2. _____     |
| 3. _____ | 4. _____ ... |

Thanking you,  
Yours faithfully,

**(Signature, Date & Seal of  
Authorized Signatory of the Bidder)**

**Note:**

1. Bidders to note that above format, duly filled & signed by authorized signatory, shall be submitted along with the techno-commercial offer.
2. In case the bidder's quoted value is in excess of Rs. 10 crores, the authorized signatory for this declaration shall necessarily be the statutory auditor or cost auditor of the company (in the case of companies) or a practising cost accountant or practicing chartered accountant (in respect of suppliers other than companies).
3. In the event of false declaration, actions as per the above order and as per BHEL Guidelines shall be initiated against the bidder.

**Buyer Added Bid Specific Additional Terms & Conditions (ATC)**

<b>1.</b>	<b>PRE QUALIFICATION CRITERIA: AS PER ENCLOSED PQR CHECKLIST</b>
<b>2.</b>	<b>SCOPE OF SUPPLY: AS PER ANNEXURE - A</b>
<b>3.</b>	<b>PRICE BASIS:</b> Price in INR should be quoted for FOR BHEL HEEP HARIDWAR basis
<b>4.</b>	<p><b>TAXES &amp; DUTIES:</b></p> <p><b>4.1</b> The Supplier/Vendor shall pay all (save the specific exclusions as enumerated in this clause) taxes, fees, license, charges, deposits, duties, tools, royalty, commissions, other charges, etc. which may be levied on the input goods &amp; services consumed and output goods &amp; services delivered in course of his operations in executing the contract. In case BHEL is forced to pay any of such taxes/duties, BHEL shall have the right to recover the same from his bills or otherwise as deemed fit along with the applicable overheads @5% and interest on the total value (i. e. amount paid by BHEL + overhead)</p> <p>However, provisions regarding <b>GST</b> on output supply (goods/service) and TDS/TCS as per Income Tax Act shall be as per following clauses.</p> <p><b>4.2 GST (Goods and Services Tax)</b></p> <p><b>4.2.1</b> Reimbursement of GST is subject to compliance of following terms and conditions. BHEL shall have the right to deny payment of GST and to recover any loss to BHEL on account of tax, interest, penalty etc. for non-compliance of any of the following condition.</p> <p><b>4.2.2</b> The admissibility of GST, taxes and duties referred in this chapter or elsewhere in the contract shall be limited to direct transactions between BHEL &amp; its Supplier/Vendor. BHEL shall not consider GST on any transaction other than the direct transaction between BHEL &amp; its Supplier/Vendor.</p> <p><b>4.2.3</b> Supplier/Vendor shall obtain prior written consent of BHEL before billing the amount towards such taxes. Where the GST laws permit more than one option or methodology for discharging the liability of tax/levy/duty, BHEL shall have the right to adopt the appropriate one considering the amount of tax liability on BHEL/Client as well as procedural simplicity with regard to assessment of the liability. The option chosen by BHEL shall be binding on the Contractor for discharging the obligation of BHEL in respect of the tax liability to the Supplier/Vendor.</p> <p><b>4.2.4</b> Supplier/Vendor has to submit GST registration certificate of the concerned state. Supplier/Vendor also needs to ensure that the submitted GST registration certificate should be in active status during the entire contract period.</p> <p><b>4.2.5</b> Supplier/Vendor has to issue Invoice/Debit Note/Credit Note indicating HSN/SAC code, Description, Value, Rate, applicable tax and other particulars in compliance with the provisions of relevant GST Act and Rules made thereunder.</p> <p><b>4.2.6</b> Supplier/Vendor has to submit GST compliant invoice within the due date of invoice as per GST Law. In case of delay, BHEL reserves the right of denial of GST payment if there occurs any hardship to BHEL in claiming the input thereof. In case of goods, Supplier/Vendor has to provide scan copy of invoice &amp; GR/LR/RR to BHEL before movement of goods starts to enable BHEL to meet its GST related compliances. Special care should be taken in case of month end transactions.</p> <p><b>4.2.7</b> Supplier/Vendor has to ensure that invoice in respect of such services which have been provided/completed on or before end of the month should not bear the date later than last working day of the month in which services are performed.</p>

**4.2.8** Subject to other provisions of the contract, GST amount claimed in the invoice shall be released on fulfilment of all the following conditions by the Supplier/Vendor: -

- a) Supply of goods and/or services have been received by BHEL.
- b) Original Tax Invoice has been submitted to BHEL.
- c) Supplier/Vendor has submitted all the documents required for processing of bill as per contract/ purchase order/ work order.
- d) In cases where e-invoicing provision is applicable, Supplier/Vendor is required to submit invoice in compliance with e-invoicing provisions of GST Act and Rules made thereunder.
- e) Supplier/Vendor has filed all the relevant GST return (e.g. GSTR-1, GSTR-3B, etc.) pertaining to the invoice submitted and submit the proof of such return along with immediate subsequent invoice. In case of final invoice/ bill, contractor has to submit proof of such return within fifteen days from the due date of relevant return.
- f) Respective invoice has appeared in BHEL's GSTR - 2A for the month corresponding to the month of invoice and in GSTR-2B of the month in which such invoices has been reported by the contractor along with status of ITC availability as "YES" in GSTR-2B. Alternatively, BG of appropriate value may be furnished which shall be valid at least one month beyond the due date of confirmation of relevant payment of GST on GSTN portal or sufficient security is available to adjust the financial impact in case of any default by the Supplier/Vendor.
- g) Supplier/Vendor has to submit an undertaking confirming the payment of all due GST in respect of invoices pertaining to BHEL.

**4.2.9** Any financial loss arises to BHEL on account of failure or delay in submission of any document as per contract/purchase order/work order at the time of submission of Tax invoice to BHEL, shall be deducted from Supplier/Vendor's bill or otherwise as deemed fit.

**4.2.10** TDS as applicable under GST law shall be deducted from Supplier/Vendor's bill.

**4.2.11** Supplier/Vendor shall comply with the provisions of e-way bill wherever applicable. Further wherever provisions of GST Act permits, all the e-way bills, road permits etc. required for transportation of goods needs to be arranged by the contractor.

**4.2.12** Supplier/Vendor shall be solely responsible for discharging his GST liability according to the provisions of GST Law and BHEL will not entertain any claim of GST/interest/penalty or any other liability on account of failure of Supplier/Vendor in complying the provisions of GST Law or discharging the GST liability in a manner laid down thereunder.

**4.2.13** In case declaration of any invoice is delayed by the vendor in his GST return or any invoice is subsequently amended/altere/deleted on GSTN portal which results in any adverse financial implication on BHEL, the financial impact thereof including interest/penalty shall be recovered from the Supplier/Vendor's due payment.

**4.2.14** Any denial of input credit to BHEL or arising of any tax liability on BHEL due to noncompliance of GST Law by the Supplier/Vendor in any manner, will be recovered along with liability on account of interest and penalty (if any) from the payments due to the Supplier/Vendor.

**4.2.15** In the event of any ambiguity in GST law with respect to availability of input credit of GST charged on the invoice raised by the contractor or with respect to any other matter having impact on BHEL, BHEL's decision shall be final and binding on the Supplier/Vendor.

	<p><b>4.2.16 Variation in Taxes &amp; Duties:</b>  Any upward variation in GST shall be considered for reimbursement provided supply of goods and services are made within schedule date stipulated in the contract or approved extended schedule for the reason solely attributable to BHEL. However downward variation shall be subject to adjustment as per actual GST applicability.  In case the Government imposes any new levy/tax on the output service/goods after price bid opening, the same shall be reimbursed by BHEL at actual. The reimbursement under this clause is restricted to the direct transaction between BHEL and its Supplier/Vendor only and within the contractual delivery period only.</p> <p>a) In case any new tax/levy/duty etc. becomes applicable after the date of Bidder's offer but before opening of the price Bid, the Bidder/ Supplier/Vendor must convey its impact on his price duly substantiated by documentary evidence in support of the same before opening of price bid. Claim for any such impact after opening the price bid will not be considered by BHEL for reimbursement of tax or reassessment of offer.</p> <p><b>4.3 Income Tax:</b>  <b>TDS/TCS</b> as applicable under Income Tax Act, 1961 or rules made thereunder shall be deducted/collected from Supplier/Vendor's bill.</p>
5.	<b>MATERIAL DISPATCH CLEARANCE CERTIFICATE: NA</b>
6.	<b>INSPECTION / INSPECTION &amp; TESTING AT SUPPLIERS WORKS: NA</b>
7.	<b>DELIVERY PERIOD: AS PER ANNEXURE - A</b>
8.	<b>TRANSIT INSURANCE:</b> Transit Insurance of material is in Supplier/Vendor's scope. Supplier/Vendor shall insure the material at their cost for transportation.
9.	<p><b>a) PAYMENT TERMS:</b></p> <p>i. <b>FOR NON-MSME BIDDERS:</b> 100% PAYMENT ALONG WITH TAXES, FREIGHT &amp; INSURANCE WILL BE MADE AFTER RECEIPT AND ACCEPTANCE OF MATERIAL AND WITHIN 90 DAYS FROM THE DATE OF RECEIPT SUBJECT TO SUBMISSION OF NON-DISCREPANT DOCUMENTS. (MSME MEANS MICRO, SMALL &amp; MEDIUM ENTERPRISES) (THIS IS IN SUPERSESSION OF 10 DAYS' TIME AS PROVIDED IN CLAUSE 12 OF GEM GTC).</p> <p>ii. <b>FOR MSE BIDDER:</b> FOR MSES (COVERED UNDER MSME ACT), 100% PAYMENT ALONG WITH TAXES, FREIGHT &amp; INSURANCE WILL BE MADE AFTER RECEIPT AND ACCEPTANCE OF MATERIAL AND WITHIN 45 DAYS FROM THE DATE OF RECEIPT SUBJECT TO SUBMISSION OF NON-DISCREPANT DOCUMENTS OR AS PRESCRIBED IN THE RELEVANT ACT. BENEFITS OF MSE (SUCH AS EMD WAIVER, TENDER FEE EXEMPTION, PRICE PREFERENCE, PAYMENT PREFERENCE ETC.) WILL BE GIVEN ONLY TO THOSE MSE VENDORS WHO ARE MANUFACTURERS OF OFFERED ITEMS AGAINST THE NIT. NO MSE BENEFITS SHALL BE PROVIDED TO AGENTS / STOCKISTS /DEALERS / TRADERS ETC. FOR THE ITEMS OFFERED BUT NOT MANUFACTURED BY THEMSELVES."</p> <p>iii. <b>FOR MEDIUM ENTERPRISES:</b> 100% PAYMENT ALONG WITH TAXES, FREIGHT &amp; INSURANCE WILL BE MADE AFTER RECEIPT AND ACCEPTANCE OF MATERIAL AND WITHIN 60 DAYS FROM THE DATE OF RECEIPT SUBJECT TO SUBMISSION OF NON-DISCREPANT DOCUMENTS AS PER TERMS AND CONDITIONS OF PURCHASE ORDER.</p> <p>iv. PLEASE NOTE THAT VENDOR TO ADHERE TO THE PAYMENT TERMS AS PER ABOVE. NO DEVIATION IN PAYMENT TERMS SHALL BE ACCEPTED. VENDOR TO SUBMIT THEIR OFFER ACCORDINGLY.</p> <p>v. However, GST amount shall be reimbursed in line with compliance to Cl. No. 4 (Taxes &amp; Duties) above.</p> <p>vi. IT MAY BE NOTED THAT STANDARD PAYMENT TIMELINE/TERMS AS MENTIONED/PRINTED IN THE GEM BID SHALL NOT BE APPLICABLE. PAYMENT TERMS SHALL BE AS PER ABOVE ONLY.</p>

	<b>b) NO INTEREST PAYABLE TO CONTRACTOR:</b> No interest shall be payable on the security deposit or any other money due to the contractor”.
<b>10.</b>	<b><u>DOCUMENTS REQUIRED ALONG WITH DISPATCH OF MATERIAL/BILLING DOCUMENTS:</u></b> The following documents are required to be sent with material dispatch/Billing Documents: <ul style="list-style-type: none"> <li>• Original Tax Invoice (As per Cl. No. 4 above).</li> <li>• Copy of LR.</li> <li>• GST COMPLIANCE CERTIFICATE</li> <li>• Warranty / Guarantee Certificate.</li> <li>• Certificate of compliance</li> </ul>
<b>11.</b>	<b><u>BANK DETAILS FOR EMD &amp; PERFORMANCE SECURITY SUBMISSION:</u></b> Not Applicable.
<b>12.</b>	<b><u>EMD:</u></b> Not Applicable.
<b>13.</b>	<b><u>PERFORMANCE SECURITY:</u></b> Not Applicable.
<b>14.</b>	<b><u>BREACH OF CONTRACT, REMEDIES AND TERMINATION:</u></b> <b>14.1</b> The following shall amount to breach of contract: <ol style="list-style-type: none"> <li>I. Non-supply of material/ non-completion of work by the Supplier/Vendor within scheduled delivery/ completion period as per contract or as extended from time to time.</li> <li>II. The Supplier/Vendor fails to perform as per the activity schedule and there are sufficient reasons even before expiry of the delivery/ completion period to justify that supplies shall be inordinately delayed beyond contractual delivery/ completion period.</li> <li>III. The Supplier/Vendor delivers equipment/ material not of the contracted quality.</li> <li>IV. The Supplier/Vendor fails to replace the defective equipment/ material/ component as per guarantee clause.</li> <li>V. Withdrawal from or abandonment of the work by the Supplier/Vendor before completion as per contract.</li> <li>VI. Assignment, transfer, subletting of Contract by the Supplier/Vendor without BHEL’s written permission resulting in termination of Contract or part thereof by BHEL.</li> <li>VII. Non-compliance to any contractual condition or any other default attributable to Supplier/Vendor.</li> <li>VIII. Any other reason(s) attributable to Vendor towards failure of performance of contract. In case of breach of contract, BHEL shall have the right to terminate the Purchase Order/ Contract either in whole or in part thereof without any compensation to the Supplier/Vendor.</li> <li>IX. Any of the declarations furnished by the contractor at the time of bidding and/ or entering into the contract for supply are found untruthful and such declarations were of a nature that could have resulted in non-award of contract to the contractor or could expose BHEL and/ or Owner to adverse consequences, financial or otherwise.</li> <li>X. Supplier/Vendor is convicted of any offence involving corrupt business practices, antinational activities or any such offence that compromises the business ethics of BHEL, in violation of the Integrity Pact entered into with BHEL has the potential to harm the overall business of BHEL/ Owner.</li> </ol>

**Note-** Once BHEL considers that a breach of contract has occurred on the part of Supplier/Vendor, BHEL shall notify the Supplier/Vendor by way of notice in this regard. Contractor shall be given an opportunity to rectify the reasons causing the breach of contract within a period of 14 days.

In case the contractor fails to remedy the breach, as mentioned in the notice, to the satisfaction of BHEL, BHEL shall have the right to take recourse to any of the remedial actions available to it under the relevant provisions of contract.

#### **14.2 Remedies in case of Breach of Contract.**

- i) Wherein the period as stipulated in the notice issued under clause 14.1 has expired and Supplier/Vendor has failed to remedy the breach, BHEL will have the right to terminate the contract on the ground of "Breach of Contract" without any further notice to contractor.
- ii) Upon termination of contract, BHEL shall be entitled to recover an amount equivalent to 10% of the Contract Value for the damages on account of breach of contract committed by the Supplier/Vendor. This amount shall be recovered by way of encasing the security instruments like performance bank guarantee etc. available with BHEL against the said contract. In case the value of the security instruments available is less than 10% of the contract value, the balance amount shall be recovered from other financial remedies (i.e. available bills of the Supplier/Vendor, retention amount, from the money due to the Supplier/Vendor etc. with BHEL) or the other legal remedies shall be pursued.
- iii) wherever the value of security instruments like performance bank guarantee available with BHEL against the said contract is 10% of the contract value or more, such security instruments to the extent of 10% contract value will be encashed. In case no security instruments are available or the value of the security instruments available is less than 10% of the contract value, the 10% of the contract value or the balance amount, as the case may be, will be recovered in all or any of the following manners:
- iv) In case the amount recovered under sub clause (a) above is not sufficient to fulfil the amount recoverable then; a demand notice to deposit the balance amount within 30 days shall be issued to Supplier/Vendor.
- v) If Supplier/Vendor fails to deposit the balance amount within the period as prescribed in demand notice, following action shall be taken for recovery of the balance amount:
  - a) from dues available in the form of Bills payable to defaulted Supplier/Vendor against the same contract.
  - b) If it is not possible to recover the dues available from the same contract or dues are insufficient to meet the recoverable amount, balance amount shall be recovered from any money(s) payable to Supplier/Vendor under any contract with other Units of BHEL including recovery from security deposits or any other deposit available in the form of security instruments of any kind against Security deposit or EMD.
- vi) In-case recoveries are not possible with any of the above available options, Legal action shall be initiated for recovery against defaulted supplier/Vendor.
- vii) It is an agreed term of contract that this amount shall be a genuine pre-estimate of damages that BHEL would incur in completion of balance contractual obligation of the contract through any other agency and BHEL will not be required to furnish any other evidence to the Supplier/Vendor for the purpose of estimation of damages.

viii) In addition to the above, imposition of liquidated damages, debarment, termination, de-scoping, short-closure, etc., shall be applied as per provisions of the contract.

**Note:**

- 1) The defaulting Supplier/Vendor shall not be eligible for participation in any of the future enquiries floated by BHEL to complete the balance work. The defaulting contractor shall mean and include:
  - (a) In case defaulted Supplier/Vendor is the Sole Proprietorship Firm, any Sole Proprietorship Firm owned by same Sole Proprietor.
  - (b) In case defaulted Supplier/Vendor is The Partnership Firm, any firm comprising of same partners/ some of the same partners; or sole proprietorship firm owned by any partner(s) as a sole proprietor.

**LD against delay in executed supply in case of Termination of Contract:**

LD against delay in executed supply shall be calculated in line with LD clause no. 18.0 below, for the delay attributable to Supplier/Vendor. For limiting the maximum value of LD, contract value shall be taken as Executed Value of supply till termination of contract.

Method for calculation of "LD against delay in executed supply in case of termination of contract" is given below.

- i. Let the time period from scheduled date of start of supply till termination of contract excluding the period of Hold (if any) not attributable to contractor = T1
- ii. Let the value of executed supply till the time of termination of contract = X
- iii. Let the Total Executable Value of supply for which inputs/fronts were made available to Supplier/Vendor and were planned for execution till termination of contract = Y
- iv. Delay in executed supply attributable to Supplier/Vendor i.e.  $T2 = [1 - (X/Y)] \times T1$
- v. LD shall be calculated in line with LD clause (clause 18.0) of the Contract for the delay attributable to Supplier/Vendor taking "X" as Contract Value and "T2" as period of delay attributable to Supplier/Vendor.

**15. BILL TO/ SHIP TO ADDRESS:**

<b><u>Shipping Address as below:</u></b>	<b><u>Billing address as below:</u></b>
Shipping Section, Central Plant Stores, HEEP, BHEL, Haridwar-249403 Uttarakhand, HARIDWAR, UTTARAKHAND-249403, India	HEAVY ELECTRICALS EQUIPMENT PLANT, BHEL, RANIPUR, HARIDWAR, Haridwar, Uttarakhand, 249403 GST No.: 05AAACB4146P1ZL

**16. GUARANTEE/WARRANTY:** Standard Guarantee / Warrantee period of 1 year is applicable from the date of receipt of material at BHEL Haridwar as per Gem GTC

**17. MICRO AND SMALL ENTERPRISES (MSE):**

Any Bidder falling under MSE category shall furnish the following details & submit documentary evidence/ Govt. Certificate etc. in support of the same along with their techno-commercial offer.

Type under MSE	SC/ST owned	Women owned	Others (excluding SC/ ST & Women Owned)
Micro			

	Small			
18.	<p><b>Note:</b> If the bidder does not furnish the above, offer shall be processed construing that the bidder is not falling under MSE category.</p> <p>a) MSE suppliers can avail the intended benefits in respect of the procurements related to the Goods and Services only (Definition of Goods and Services as enumerated by Govt. of India vide Office Memorandum F. No. 21(8)/2011-MA dtd. 09/11/2016 office of AS &amp; DC, MSME) only if they submit along with the offer, attested copies of either UDYAM Registration. Date to be reckoned for determining the deemed validity will be the last date of Technical Bid submission. Non-submission of supporting document in GeM portal will lead to consideration of their bids at par with other bidders. No benefits shall be applicable for this enquiry if the above required documents are not uploaded at the time of bid submission. Documents submitted by the bidder shall be verified by BHEL for rendering the applicable benefits.</p> <p><b><u>DIVISION BETWEEN MSE AND NON MSE L1 WILL BE AS BELOW:</u></b></p> <p>If price quoted by MSE vendor is within the price band of L1+15%, then 25% quantity of the respective item (rounded off to nearest number) shall be offered to MSE vendor subject to matching the L1 prices. if the quantity required is 1 number (as such non-divisible), MSE quoting with in price preference of L1+15% shall be offered 100% quantity subject to matching the L1 prices.</p> <p>MSE/MII: the supplier needs to submit/update MSE/MII credentials on gem portal during profile updation / offer submission stage. the MSE data submitted is cross verified by gem with govt. of INDIA UDYAM/NSIC database through API integration on real time basis and for mii, a self-declaration is being given and authenticated by AADHAR OTP. if the seller fails to claim MSE/MII provision on gem portal at profile updation / bid submission stage, the said seller will become ineligible for getting the MSE/MII benefits for that bid automatically. the vendor can always</p>			
19.	<p><b><u>LIQUIDATED DAMAGE:</u></b></p> <p>If the Seller/Service Provider fails to deliver any or all of the Goods/Services within the original/re-fixed delivery period(s) specified in the contract/PO, the Buyer/BHEL will be entitled to deduct/recover the Liquidated Damages for the delay, unless covered under Force Majeure conditions aforesaid, @ 0.5% of the contract value of delayed quantity per week or part of the week of delayed period as pre-estimated damages not exceeding 10% of the contract value of delayed quantity without any controversy/dispute of any sort whatsoever.</p>			
19.	<p><b><u>INTEGRITY PACT (IP):</u></b> Not Applicable</p>			
20.	<p><b><u>PREFERENCE TO MAKE IN INDIA:</u></b> Applicable</p> <p>For this procurement, the local content to categorize a Supplier/Vendor as a Class I local supplier/ Class II local Supplier/Non-Local Supplier and purchase preferences to Class I local supplier, is as defined in Public Procurement (Preference to Make in India), Order 2017” Dt. 19.07.2024 issued vide Order No. P-45021/2/2017-PP(BE-II)-Part(4)Vol.II. In case of subsequent orders issued by the nodal ministry, changing the definition of local content for the items of the GeM Bid, the same shall be applicable even if issued after issue of this GeM Bid, but before opening of Part-II bids against this GeM Bid.</p>			

Suppliers who have qualified and received incentive under PLI scheme will be deemed CLASS-II local suppliers unless they are already CLASS I local suppliers) to encourage indigenization.

kindly submit MAKE IN INDIA certificate as per attached format only.

**PENAL PROVISIONS FOR FALSE SELF DECLARATION OF MII, IN CASE OF CONTRACT MORE THAN RS 10 CRS.**

For contracts valuing more than Rs. 10 crores, local content (in cases of self-certification submitted by bidders at the time of tendering) will be re-verified during execution of contract by cost/ chartered accountant, and in case of defaults, penalty upto 10% of the contract value shall be imposed.

For this procurement, the local content to categorize a supplier as a CLASS I local supplier/ CLASS II local supplier/ non-local supplier and purchase preference to class i local supplier, is as defined in public procurement (preference to MAKE IN INDIA), order 2017 dated 19.07.2024 issued by DPIIT. in case of subsequent orders issued by the nodal ministry, changing the definition of local content for the items of the nit, the same shall be applicable even if issued after issue of this NIT, but before opening of PART-II bids against this NIT.

**20.1 Compliance to Restrictions under Rule 144 (xi) of GFR 2017:**

- I. Any bidder from a country which shares a land border with India will be eligible to bid in this tender only if the bidder is registered with the Competent Authority. The Competent Authority for the purpose of this Clause shall be the Registration Committee constituted by the Department for Promotion of Industry and Internal Trade (DPIIT).
- II. "Bidder" (including the term 'tenderer', 'consultant' or 'service provider' in certain contexts) means any person or firm or company, including any member of a consortium or joint venture (that is an association of several persons, or firms or companies), every artificial juridical person not falling in any of the descriptions of bidders stated hereinbefore, including any agency branch or office controlled by such person, participating in a procurement process.
- III. "Bidder from a country which shares a land border with India" for the purpose of this Clause means: -
  - a. An entity incorporated established or registered in such a country; or
  - b. A subsidiary of an entity incorporated established or registered in such a country; or
  - c. An entity substantially controlled through entities incorporated, established or registered in such a country; or
  - d. An entity whose beneficial owner is situated in such a country; or
  - e. An Indian (or other) agent of such an entity; or
  - f. A natural person who is a citizen of such a country; or
  - g. A consortium or joint venture where any member of the consortium or joint venture falls under any of the above.
- IV. The beneficial owner for the purpose of (III) above will be as under:
  1. In case of a company or Limited Liability Partnership, the beneficial owner is the natural person(s), who, whether acting alone or together or through one or more

juridical person, has a controlling ownership interest or who exercises control through other means.

Explanation

- a. "Controlling ownership interest" means ownership of or entitlement to more than twenty-five per cent of shares or capital or profits of the company.
- b. "Control" shall include the right to appoint majority of the directors or to control the management or policy decisions including by virtue of their shareholding or management rights or shareholders agreements or voting agreements.

2. In case of a partnership firm, the beneficial owner is the natural person(s) who, whether acting alone or together, or through one or more juridical person, has ownership of entitlement to more than fifteen percent of capital or profits of the partnership.

In case of an unincorporated association or body of individuals, the beneficial owner is the natural person(s), who, whether acting alone or together, or through one or more juridical person has ownership of or entitlement to more than fifteen percent of the property or capital or profits of the such association or body of individuals.

4. Where no natural person is identified under (1) or (2) or (3) above, the beneficial owner is the relevant natural person who holds the position of senior managing official;

5. In case of a trust, the identification of beneficial owner(s) shall include identification of the author of the trust, the trustee, the beneficiaries with fifteen percent or more interest in the trust and any other natural person exercising ultimate effective control over the trust through a chain of control or ownership.

V. An Agent is a person employed to do any act for another, or to represent another in dealings with third person. Note:

- (i) The bidder shall provide undertaking for their compliance to this Clause.

Registration of the bidder with Competent Authority should be valid at the time of submission of bids and at the time of acceptance of the bids.

**21. Settlement of Dispute**

If any dispute or difference of any kind whatsoever shall arise between BHEL and the Supplier/Vendor, arising out of the contract for the performance of the work whether during the progress of contract termination, abandonment or breach of the contract, it shall in the first place referred to Designated Engineer for amicable resolution by the parties. Designated Engineer (to be nominated by BHEL for settlement of disputes arising out of the contract) who within 60 days after being requested shall give written notice of his decision to the contractor. Save as hereinafter provided, such decision in respect of every matter so referred shall forthwith be given effect to by the Supplier/Vendor who shall proceed with the work with all due diligence, whether he or BHEL desires to resolve the dispute as hereinafter provided or not.

If after the Designated Engineer has given written notice of this decision to the party and no intention to pursue the dispute has been communicated to him by the affected party within 30 days from the receipt of such notice, the said decision shall become final and binding on

the parties. In the event the Supplier/Vendor being dissatisfied with any such decision or if amicable settlement cannot be reached then all such disputed issues shall be resolved through conciliation in terms of the BHEL Conciliation Scheme 2018 as per Clause 21.1

### **21.1 Conciliation:**

Any dispute, difference or controversy of whatever nature howsoever arising under or out of or in relation to this Agreement (including its interpretation) between the Parties, and so notified in writing by either Party to the other Party (the "Dispute") shall, in the first instance, be attempted to be resolved amicably in accordance with the conciliation procedure as per BHEL Conciliation Scheme 2018. The proceedings of Conciliation shall broadly be governed by Part III of the Arbitration and Conciliation Act 1996 or any statutory modification thereof and as provided in - "Procedure for conduct of conciliation proceedings" (as available in [www.bhel.com](http://www.bhel.com))).

**Note:** Ministry of Finance has issued OM reference No. 1/2/24 dated 03.06.2024 regarding "Guidelines for Arbitration and Mediation in Contracts of Domestic Public Procurement. In the said OM it has been recommended that Government departments/ Entities/agencies are to encourage mediation under the Mediation Act. 2023. The said Act has not yet been notified by the Government. Therefore, the clause "Settlement of Disputes" shall be modified accordingly as and when the Mediation Act 2023 gets notified.

### **21.2 ARBITRATION:**

21.2.1 Except as provided elsewhere in this Contract, in case Parties are unable to reach amicable settlement (whether by Conciliation to be conducted as provided in Clause 21.1 herein above or otherwise) in respect of any dispute or difference; arising out of the formation, breach, termination, validity or execution of the Contract; or, the respective rights and liabilities of the Parties; or, in relation to interpretation of any provision of the Contract; or, in any manner touching upon the Contract (hereinafter referred to as the 'Dispute'), then, either Party may, refer the disputes to Arbitral Institution (to be identified by the contract issuing agency (eg. "IIAC" (India International Arbitration Centre) for Delhi/NCR offices) and such dispute to be adjudicated by Sole Arbitrator appointed in accordance with the Rules of said Arbitral Institution.

21.2.2 A party willing to commence arbitration proceeding shall invoke Arbitration Clause by giving notice to the other party in terms of section 21 of the Arbitration & Conciliation Act, 1996 (hereinafter referred to as the 'Notice') before referring the matter to arbitral institution. The Notice shall be addressed to the Head of the Region, Power Sector/ Unit, BHEL, executing the Contract and shall contain the particulars of all claims to be referred to arbitration with sufficient detail and shall also indicate the monetary amount of such claim including interest, if any.

21.2.3 After expiry of 30 days from the date of receipt of aforesaid notice, the party invoking the Arbitration shall submit that dispute to the Arbitral Institutions as identified by the contract issuing agency) and that dispute shall be adjudicated in accordance with their respective Arbitration Rules. The matter shall be adjudicated by a Sole Arbitrator who shall necessarily be a Retd. Judge having considerable experience in commercial matters to be appointed/nominated by the respective institution. The cost/expenses pertaining to the said Arbitration shall also be governed in accordance with the Rules of the

	<p>respective Arbitral Institution. The decision of the party invoking the Arbitration for reference of dispute to a specific Arbitral institution for adjudication of that dispute shall be final and binding on both the parties and shall not be subject to any change thereafter. The institution once selected at the time of invocation of dispute shall remain unchanged.</p> <p>21.2.4 The fee and expenses shall be borne by the parties as per the Arbitral Institutional rules.</p> <p>21.2.5 The Arbitration proceedings shall be in English language and the seat and venue of Arbitration shall be HARIDWAR.</p> <p>21.2.6 Subject to the above, the provisions of Arbitration &amp; Conciliation Act 1996 and any amendment thereof shall be applicable. All matters relating to this Contract and arising out of invocation of Arbitration clause are subject to the exclusive jurisdiction of the Court(s) situated at HARIDWAR.</p> <p>21.2.7 Notwithstanding any reference to the Designated Engineer or Conciliation or Arbitration herein, a. the parties shall continue to perform their respective obligations under the Contract unless they otherwise agree. Settlement of Dispute clause cannot be invoked by the Contractor, if the Contract has been mutually closed or 'No Demand Certificate' has been furnished by the Contractor or any Settlement Agreement has been signed between the Employer and the Contractor.</p> <p>21.2.8 It is agreed that Mechanism of resolution of disputes through arbitration shall be available only in the cases where the value of the dispute is less than Rs. 10 Crores.</p> <p>21.2.9 In case the disputed amount (Claim, Counter claim including interest is Rs. 10 crores and above, the parties shall be within their rights to take recourse to remedies other than Arbitration, as may be available to them under the applicable laws after prior intimation to the other party. Subject to the aforesaid conditions, provisions of the Arbitration and Conciliation Act, 1996 and any statutory modifications or re-enactment thereof as amended from time to time, shall apply to the arbitration proceedings under this clause.</p> <p>21.2.10 In case, multiple arbitrations are invoked (whether sub-judice or arbitral award passed) by any party to under this contract, then the cumulative value of claims (including interest claimed or awarded) in all such arbitrations shall be taken in account while arriving at the total claim in dispute for the subject contract for the purpose of clause 21.2.9. Disputes having cumulative value of less than 10 crores shall be resolved through arbitration and any additional dispute shall be adjudicated by the court of competent jurisdiction.</p> <p><b>21.3 In case of Contract with Public Sector Enterprise (PSE) or a Government Department, the following shall be applicable:</b></p> <p>In the event of any dispute or difference relating to the interpretation and application of the provisions of commercial contract(s) between Central Public Sector Enterprises (CPSEs)/ Port Trusts inter se and also between CPSEs and Government Departments/Organizations (excluding disputes concerning Railways, Income Tax, Customs &amp; Excise Departments), such dispute or difference shall be taken up by either party for resolution through AMRCD (Administrative Mechanism for Resolution of CPSEs Disputes) as mentioned in DPE OM No. 05/0003/2019-FTS-10937 dated 14-122022 as amended from time to time.</p>
<p><b>22.</b></p>	<p><b>JURISDICTION</b></p> <p>Subject to clause 21 of this contract, the Civil Court having original Civil Jurisdiction HARIDWAR shall alone have exclusive jurisdiction in regard to all matters in respect of the Contract.</p>

**GOVERNING LAWS**

The contract shall be governed by the Law for the time being in force in the Republic of India.

**23. Force Majeure**

23.1 "Force Majeure" shall mean circumstance which is:

- a) beyond control of either of the parties to contract,
  - b) either of the parties could not reasonably have provided against the event before entering into the contract,
  - c) having arisen, either of the parties could not reasonably have avoided or overcome, and
  - d) is not substantially attributable to either of the parties
- And

Prevents the performance of the contract,

Such circumstances include but shall not be limited to:

- i. War, hostilities, invasion, act of foreign enemies.
- ii. Rebellion, terrorism, revolution, insurrection, military or usurped power, or civil war.
- iii. Riot, commotion or disorder by persons other than the contractor's personnel and other employees of the contractor and sub-contractors.
- iv. Strike or lockout not solely involving the contractor's personnel and other employees of the contractor and sub-contractors.
- v. Encountering munitions of war, explosive materials, ionizing radiation or contamination by radio-activity, except as may be attributable to the contractor's use of such munitions, explosives, radiation or radio- activity.
- vi. Natural catastrophes such as earthquake, tsunami, volcanic activity, hurricane or typhoon, flood, fire, cyclones etc.
- vii. Epidemic, pandemic etc.

23.2 The following events are explicitly excluded from Force Majeure and are solely the responsibilities of the non-performing party: a) any strike, work-to-rule action, go-slow or similar labour difficulty (b) late delivery of equipment or material (unless caused by Force Majeure event) and (c) economic hardship.

23.3 If either party is prevented, hindered or delayed from or in performing any of its obligations under the Contract by an event of Force Majeure, then it shall notify the other in writing of the occurrence of such event and the circumstances thereof within 15 (fifteen) days after the occurrence of such event.

23.4 The party who has given such notice shall be excused from the performance or punctual performance of its obligations under the Contract for so long as the relevant event of Force Majeure continues and to the extent that such party's performance is prevented, hindered or delayed. The Time for Completion shall be extended by a period of time equal to period of delay caused due to such Force Majeure event.

23.5 Delay or non-performance by either party hereto caused by the occurrence of any event of Force Majeure shall not

- i. Constitute a default or breach of the Contract.
- ii. Give rise to any claim for damages or additional cost expense occasioned thereby, if and to the extent that such delay or non-performance is caused by the occurrence of an event of Force Majeure.

	<p>23.6 BHEL at its discretion may consider short closure of contract after 1 year of imposition of Force Majeure in line with extant guidelines. In any case, Supplier/Vendor cannot consider deemed short-closure after 1 year of imposition of Force Majeure.</p>		
<p><b>24.</b></p>	<p><b>Non-Disclosure Agreement:</b> Not Applicable</p>		
<p><b>25.</b></p>	<p><b>Cartel Formation</b>  The Bidder declares that they will not enter into any illegal or undisclosed agreement or understanding, whether formal or informal with other Bidder(s). This applies in particular to prices, specifications, certifications, subsidiary contracts, submission or non-submission of bids or any other actions to restrict competitiveness or to introduce cartelization in the bidding process. In case, the Bidder is found having indulged in above activities, suitable action shall be taken by BHEL as per extant policies/ guidelines</p>		
<p><b>26.</b></p>	<p><b>Fraud Prevention Policy</b>  Bidder along with its associate /collaborators /sub-contractors /sub-vendors / consultants / service providers shall strictly adhere to BHEL Fraud Prevention Policy displayed on BHEL website <a href="http://www.bhel.com">http://www.bhel.com</a> and shall immediately bring to the notice of BHEL Management about any fraud or suspected fraud as soon as it comes to their notice.</p>		
<p><b>27.</b></p>	<p><b><u>Suspension of Business Dealings with Suppliers / Contractors:</u></b>  The offers of the bidders who are under suspension as also the offers of the bidders, who engage the services of the banned firms / principal / agents, shall be rejected. The list of banned firms is available on BHEL web site <a href="http://www.bhel.com">www.bhel.com</a>.</p> <p>If any bidder / supplier / contractor during pre-tendering / tendering / post tendering / award / execution / post-execution stage indulges in any act, including but not limited to, malpractices, cheating, bribery, fraud or and other misconduct or formation of cartel so as to influence the bidding process or influence the price or tampers the tendering process or acts or omits in any manner which tantamount to an offence punishable under any provision of the Indian Penal Code, 1860 (Bhartiya Nyaya Samhita 2023) or any other law in force in India, or does anything which is actionable under the Guidelines for Suspension of Business dealings, action may be taken against such bidder / supplier / contractor as per extant guidelines of the company available on <a href="http://www.bhel.com">www.bhel.com</a> and / or under applicable legal provisions. Guidelines for suspension of business dealings is available in the webpage:  <a href="https://www.bhel.com/guidelines-suspension-business-dealings-supplierscontractors">https://www.bhel.com/guidelines-suspension-business-dealings-supplierscontractors</a></p>		
<p><b>28.</b></p>	<p>Bid should be free from correction, overwriting, using corrective fluid, etc. Any interlineation, cutting, erasure or overwriting shall be valid only if they are attested under full signature(s) of person(s) signing the bid else bid shall be liable for rejection. In the event of any Technical or Commercial queries, the same may please be addressed to the following BHEL concerned before Part I opening-</p> <table border="1" data-bbox="284 1619 1490 1759"> <tr> <td data-bbox="284 1619 899 1759"> <p>Manager/PPX-DABG  Email id- <a href="mailto:chirag@bhel.in">chirag@bhel.in</a>  Ph. No.- +91-7660015900</p> </td> <td data-bbox="899 1619 1490 1759"> <p>Engineer/PPX-DABG  Email id- <a href="mailto:rajankumar@bhel.in">rajankumar@bhel.in</a>  Ph. No.- +91-9193333885</p> </td> </tr> </table>	<p>Manager/PPX-DABG  Email id- <a href="mailto:chirag@bhel.in">chirag@bhel.in</a>  Ph. No.- +91-7660015900</p>	<p>Engineer/PPX-DABG  Email id- <a href="mailto:rajankumar@bhel.in">rajankumar@bhel.in</a>  Ph. No.- +91-9193333885</p>
<p>Manager/PPX-DABG  Email id- <a href="mailto:chirag@bhel.in">chirag@bhel.in</a>  Ph. No.- +91-7660015900</p>	<p>Engineer/PPX-DABG  Email id- <a href="mailto:rajankumar@bhel.in">rajankumar@bhel.in</a>  Ph. No.- +91-9193333885</p>		
<p><b>29.</b></p>	<p>Order of Precedence:  In the event of any ambiguity or conflict between the Tender Documents, the order of precedence shall be in the order below:</p> <p>a) Amendments/Clarifications/Corrigenda/Errata etc. issued in respect of the tender documents by BHEL.</p>		

	<p>b) Buyer Added Bid Specific ATC  c) GeM Bid Technical Conditions of Contract (TCC)  d) GeM GTC</p>
<p><b>30.</b></p>	<p><b>NOTE:</b></p> <ol style="list-style-type: none"> <li>1. In the event of our customer order covering this tender being cancelled /placed on hold /otherwise modified, BHEL would be constrained to accordingly cancel / hold / modify the tender at any stage of execution.</li> <li>2. BHEL may negotiate the L1 rate, if not meeting our budget / estimated cost. BHEL may re-float the tender opened, if L1 price is not acceptable to BHEL even after negotiation. Any deviation from the conditions specified in tender may lead to rejection of offer.</li> <li>3. Any change in applicable rates of Tax or any other statutory levies (Direct / Indirect) or any new introduction of any levy by means of statute and its corresponding liability for the deliveries beyond the agreed delivery date for reasons not attributable to BHEL will be to vendors account. BHEL will not reimburse the same and any subsequent claim in this respect will be summarily rejected.</li> <li>4. BHEL reserves its right to reject an offer due to unsatisfactory past performance by the respective Vendor in the execution of any contract to any BHEL project / Unit.</li> <li>5. The offers of the bidders who are under suspension and also the offers of the bidders, who engage the services of the banned firms /principal/agents, shall be rejected. The list of banned firms is available on BHEL web site <a href="http://www.bhel.com">www.bhel.com</a>.</li> <li>6. Recovery / deduction as applicable as per Direct and Indirect taxes as notified by Govt. Of India from time to time will be made and information/certificate for such deduction/recoveries shall be provided by BHEL to the vendor.</li> <li>7. Rest Terms and Conditions shall be as per GEM (Latest version- applicable at the time of issuance of enquiry) and enquiry ATC (Additional terms &amp; conditions).</li> <li>8. While generating invoice in GEM portal, the seller must upload scanned copy of GST invoice and the screenshot of GST portal confirming payment of GST.</li> <li>9. THE PRICE QUOTE BY BIDDER SHOULD BE INCLUSIVE OF GST.</li> <li>10. Vendor to upload/submit DIGITILY signed documents to BHEL B2B portal at the time of supply.</li> <li>11. The tender enquiry has been issued on GEM and BHEL portals for wider circulation. however, the offer is to be submitted through GEM portal only. also, all future corrigendum/corrigenda, addendum/addenda, amendments, time extensions, clarifications, etc. against the published gem bid shall be issued on gem portal only. Hence, the bidders are advised to check GEM portal only for latest updates/amendments/communications issued by BHEL against the current tender.</li> <li>12. Vendor to offer best delivery schedule in line with BHEL tender requirement. Delivery is not sacrosanct. However, offer of vendors may not be considered whose quoted delivery does not match with BHEL requirement.</li> <li>13. Data sheet of the product(s) offered in the bid, are to be uploaded along with the bid documents. Buyers can match and verify the data sheet with the product specifications offered. In case of any unexplained mismatch of technical parameters, the bid is liable for rejection.</li> </ol>

	<p>14. In case vendor (The Proprieter, Partner(s), Director(s) of our Company/Firm) have any relation or relatives employed in BHEL, vendor to inform the same specifically in their offer.</p> <p>15. Bidder shall submit the following documents along with their bid for vendor code creation:</p> <ul style="list-style-type: none"> <li>• COPY OF PAN CARD</li> <li>• COPY OF GSTIN</li> <li>• COPY OF MSE CERIFICATE</li> </ul> <p>16. The bids received from same IP address shall be outrightly rejected and shall not be considered for further evaluation.</p>
<p><b>31.</b></p>	<p><b>Grievance Redressal Mechanism</b></p> <p>To promote transparency and ensure fair treatment of all bidders, a structured Grievance Redressal Mechanism is in place to address any concerns or issues arising during the tendering process or in subsequent business dealings with the company.</p> <p>Suppliers/Contractors are requested to follow the below escalation process for grievance resolution:</p> <ol style="list-style-type: none"> <li>1. First Level: Any grievance should initially be addressed to the designated Dealing Officer, whose contact details are provided in the Notice Inviting Tender (NIT)/Contract.</li> <li>2. Second Level: If the issue remains unresolved, it may be escalated by lodging a formal grievance through the SUVIDHA Portal: <a href="https://suvidha.bhel.in/suvidha/">https://suvidha.bhel.in/suvidha/</a></li> </ol> <p>Responses will be provided in accordance with the defined escalation matrix.”</p>
<p><b>32.</b></p>	<p><b>CONFLICT OF INTEREST AMONG BIDDERS/ AGENTS</b></p> <p>“A bidder shall not have conflict of interest with other bidders. Such conflict of interest can lead to anti-competitive practices to the detriment of procuring entity's interests. The bidder found to have a conflict of interest shall be disqualified. A bidder may be considered to have a conflict of interest with one or more parties in this bidding process, if:</p> <ol style="list-style-type: none"> <li>a) They have controlling partner (s) in common; OR</li> <li>b) They receive or have received any direct or indirect subsidy/ financial stake from any of them; OR</li> <li>c) They have the same legal representative/agent for purposes of this bid; OR</li> <li>d) They have relationship with each other, directly or through common third parties, that puts them in a position to have access to information about or influence on the bid of another bidder; OR</li> <li>e) Bidder participates in more than one bid in this bidding process. participation by a bidder in more than one bid will result in the disqualification of all bids in which the parties are involved. However, this does not limit the inclusion of the components/sub-assembly/ assemblies from one bidding manufacturer in more than one bid; OR</li> <li>f) In cases of agents quoting in offshore procurements, on behalf of their principal manufacturers, one agent cannot represent two manufacturers or quote on their behalf in a particular tender enquiry. one manufacturer can also authorise only one agent/dealer. There can be only one bid from the following: <ol style="list-style-type: none"> <li>1. The principal manufacturer directly or through one INDIAN agent on his behalf; AND</li> <li>2. INDIAN/FOREIGN agent on behalf of only one principal;</li> </ol> </li> </ol>

OR

- g) A bidder or any of its affiliates participated as a consultant in the preparation of the design or technical specifications of the contract that is the subject of the bid; OR
- h) In case of a holding company having more than one independently manufacturing units, or more than one unit having common business ownership/management, only one unit should quote. Similar restrictions would apply to closely related sister companies. Bidders must proactively declare such sister/ common business/ management units in same/ similar line of business."

**Treatment of cases regarding conflict of interest:**

The bidder notes that a conflict of interest would said to have occurred in the tender process and execution of the resultant contract, in case of any of the following situations:

- i. If its personnel have a close personal, financial, or business relationship with any personnel of BHEL who are directly or indirectly related to the procurement or execution process of the contract, which can affect the decision of BHEL directly or indirectly;
- ii. The bidder (or his allied firm) provided services for the need assessment/ procurement planning of the Tender process in which it is participating;
- iii. Procurement of goods directly from the manufacturers/suppliers shall be preferred. However, if the OEM/ Principal insists on engaging the services of an agent, such agent shall not be allowed to represent more than one manufacturer/ supplier in the same tender. Moreover, either the agent could bid on behalf of the manufacturer/ supplier or the manufacturer/ supplier could bid directly but not both. In case bids are received from both the manufacturer/ supplier and the agent, bid received from the agent shall be ignored. However, this shall not debar more than one Authorised distributor (with/ or without the OEM) from quoting equipment manufactured by an Original Equipment Manufacturer (OEM) in procurements under a Proprietary Article Certificate.
- iv. A bidder participates in more than one bid in this tender process. Participation in any capacity by a Bidder (including the participation of a Bidder as a partner/ JV member or sub-contractor in another bid or vice-versa) in more than one bid shall result in the disqualification of all bids in which he is a party. However, this does not limit the participation of an entity as a sub-contractor in more than one bid if he is not bidding independently in his own name or as a member of a JV.

The Bidder declares that they have read and understood the above aspects, and the bidder confirms that such conflict of interest does not exist and undertakes that they will not enter into any illegal or undisclosed agreement or understanding, whether formal or informal with other Bidder(s), in this regard. This applies in particular to prices, specifications, certifications, subsidiary contracts, submission or non-submission of bids or any other actions to restrict competitiveness or to introduce cartelization in the bidding process. In case, the Bidder is found having indulged in above activities, the same will be considered as a violation of the tender conditions, and suitable action shall be taken by BHEL as per extant policies/ guidelines.

- 33. For supply orders placed on Indian Suppliers:** Irrespective of the value of the invoice amount, the bidder / vendor should necessarily upload the despatch & invoice details on BHEL SUVIDHA portal at <https://suvidha.bhel.in/suvidha/>, prior to despatch. All documents as per PO checklist, along with additional documents (if any), must be uploaded on the portal. It is mandatory that

	<p>tax invoices with a net amount (including taxes) exceeding Rs five lakhs uploaded on the portal are digitally signed using a Class 3 Digital Signature Certificate (DSC) issued by a licensed Certifying Authority. Submission of invoice document in hard copy is allowed for invoices with a net amount (including taxes) equal to and upto Rs. five lakhs, in case they were not digitally signed and uploaded on the portal.</p> <p>The material will not be accepted inside BHEL in absence of the above. ”</p>
<b>34.</b>	<p><b><u>Enclosure:</u></b></p> <ul style="list-style-type: none"><li>• Annexure-A: ITEM DETAILS / SCOPE OF SUPPLY</li><li>• PQR CHECKLIST</li><li>• COMMERCIAL &amp; QUALITY CHECKLIST</li><li>• Format for Declaration reg. minimum local content in line with revised public procurement</li></ul>