



REQUIREMENT OF KLAXON HORN.

The Heavy Electricals Equipment Plant (HEEP) located in Haridwar, India is one of the major manufacturing plants of Bharat Heavy Electricals Ltd. The core business of HEEP includes design and manufacture of large steam and gas turbines, turbo generators, Defense Items and so on.

Details of items details as below:

SLN	MAT CODE	ITEM DISCREPTION	TOTAL QUANTITY (NOS.)	LOT	LOT QTY (NOS.)	DELIVERY. SCHEDULE
1	W97057701080	KLAXON HORN 110VAC, 60HZ,120DB AS PER SPECIFICATION NO. DPE/TS/KH-110V60 N.STD:- SIZE: KHRR10103	52	1 ST	2	30.09.2024
2	W97057701080_1	KLAXON HORN 110VAC, 60HZ,120DB AS PER SPECIFICATION NO. DPE/TS/KH-110V60 N.STD:- SIZE: KHRR10103		2 ND	24	30.03.2025
3	W97057701080_2	KLAXON HORN 110VAC, 60HZ,120DB AS PER SPECIFICATION NO. DPE/TS/KH-110V60 N.STD:- SIZE: KHRR10103		3 rd	26	30.03.2026

1. EARLY DELIVERY IS ACCEPTABLE FOR LOT 1.
2. EARLY DELIVERY IS ACCEPTABLE FROM JAN' 2025 (FOR LOT-2).
3. EARLY DELIVERY IS ACCEPTABLE FROM JAN' 2026 (FOR LOT-3).
4. ALL VENDORS TO PROVIDE POINT WISE REPLY/CONFIRMATION ALONG WITH RELEVANT SUPPORTING DOCUMENTS TO EACH AND EVERY POINT OF **PRE-QUALIFICATION REQUIREMENT/PQR** FOR ALL ENQUIRY ITEMS. NONCOMPLIANCE OF THESE MAY LEAD TO REJECTION OF OFFER AS THESE ARE ESSENTIAL CONDITION FOR PARTICIPATING IN TENDER ENQUIRY.
5. KINDLY UPLOAD/ATTACH THE SPECIFICATION DETAILS/ CATALOGUE OF OFFERED ITEMS.
6. KINDLY **SUBMIT TECHNO-COMMERCIAL CHECKLIST** ALONG WITH YOUR OFFER.
7. VENDOR TO CONFIRM TO PROVIDE TEST CERTIFICATES AS PER MANUFACTURER'S STANDARD PRACTICE.
8. VENDOR TO CONFIRM TO PROVIDE ALL TECHNICAL PARAMETERS OF ITEM INCLUDING MANUFACTURER SERIAL NO. IN TEST CERTIFICATES AS WELL AS ON THE ITEM.
9. VENDOR TO CONFIRM TO PROVIDE INTERNAL RECORDS FOR ARMATURE COATING OF HORN.
10. VENDOR TO CONFIRM TO MENTION CURE DATE & SHELF LIFE OF O-RINGS USED IN KALXON HORN IN T.C. AS WELL AS ON THE ITEM.

11. VENDOR TO CONFIRM TO PROVIDE PACKING LIST OF ITEMS DURING DISPATCH (COVERING MAIN AND SPARES ITEMS OF KLAXON HORN). ALSO, KLAXON HORN SHALL BE IN ASSEMBLED CONDITION WITH CABLE GLAND AND CONNECTING CABLE (0.5 METER) IN LINE WITH SPECIFICATION DPE/TS/KH-110V60 AND VENDOR TO INSPECT THE SAME AND MENTION SAME IN TEST CERTIFICATES.
12. VENDOR TO CONFIRM TO PROVIDE DOCUMENTS KEEP PROPER CORRELATION WITH PO ITEMS AND THEIR QUANTITY.
13. VENDOR TO CONFIRM TO PROVIDE CERTIFICATE OF CONFORMANCE ALONG WITH MATERIAL DISPATCH.
14. VENDOR TO SUBMIT MAKE IN INDIA SELF CERTIFICATION AS PER FORMAT GIVEN ALONG WITH THE ENQUIRY

QUALIFYING CONDITIONS for KLAXON HORN

Only those manufacturers or suppliers should quote:

Sl.	PQR Requirement	Vendor Response	Vendor Response (Yes / No)
1.	who can manufacture or supply KLAXON HORNS as per national and international standards	Vendor to confirm	
2.	who can manufacture or supply KLAXON HORN as per BHEL specification no. DPE/TS/KH-110V60	Vendor to confirm	
3.	BHEL reserves the right to verify information submitted by vendor. In case the information is found to be false/incorrect, the offer shall be rejected.	Vendor to accept & confirm	

**TECHNICAL SPECIFICATION****FOR****Klaxon Horn 110 V ac, 60Hz, 120dB**

	Name	Date
Drafted by:	S. K. SINGH	02.01.2021
Approved by:	UMESH DUTT	02.01.2021



REVISION HISTORY

REV.	DATE	DESCRIPTION
0	Jan '2021	Issue
1	June'2023	Scope Of Supply added for clarity.
2	March'2024	Updated clause 5 & 6. Added "Supplier's"

**-INDEX-**

1.	SCOPE	4
2.	FEATURES	4
3.	SPECIFICATIONS	4
4.	LIMITING DIMENSIONS	4
5.	SPARES.....	4
6.	SCOPE OF SUPPLY	5
7.	DOCUMENTATION	5
8.	PACKING AND IDENTIFICATION	5

1. SCOPE

This specification pertains to motor driven Klaxon Horn (siren) which produces a clear, high output siren sound for general safety warning.

The materials and process employed in manufacturing of the Klaxon Horn shall be such that it can be used both indoors and outdoors for general safety warning.

2. FEATURES

- High output siren sound
- Rugged construction for use in all environments
- Weatherproof to IP65
- Mounting bracket for ease of installation

3. SPECIFICATIONS

Construction	Light weight Metallic Body
IP Rating	IP65
Audibility	[90 - 180] decibel
Range	[150 – 250] meter
Voltage	[105 - 115] V, 60Hz
Frequency (RPM)	[500 – 1800] Hz
Operating Temp	-30°C to +45°C
Connectivity	Marine Grade or equivalent Cable 0.5 meter
Weight	[1.5 – 5] kg
Overall Paint scheme	Preferably, RED / GREY.

4. LIMITING DIMENSIONS

Shape and Dimension for reference only.

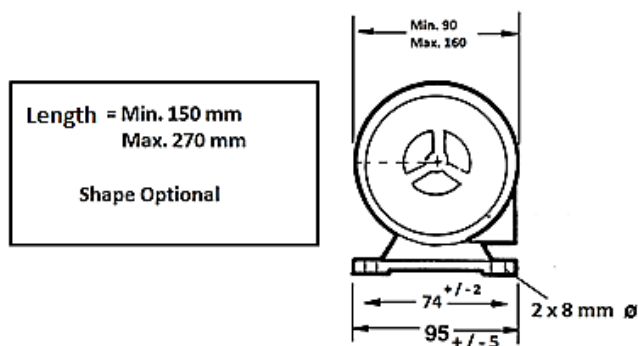

5. SPARES

One set of spares for trouble free operation for 2 years to be supplied as per manufacturer's/Supplier's recommendation.

**6. SCOPE OF SUPPLY**

1.	Klaxon Horn	01 no	To be supplied in ASSEMBLED condition.
2.	Cable Gland, M20x1.5 *	01 no	
3.	Connecting Cable	0.5 meter	
4.	Spares	01 set	As per manufacturer's/Suppliers recommendation

(*): For reference only. Cable Gland size as per manufacturer's model /make.

7. DOCUMENTATION

Vendor to provide certificate of Conformance/ Compliance.

8. PACKING AND IDENTIFICATION

- a) Items shall be packed such as to:
 - (i). Prevent ingress of moisture & dust.
 - (ii). Prevent damage during transit and storage.
- b) Each box shall be labeled regarding its content along with Purchase Order (PO) Details, PO. Item no., destination and dispatchers address.

<u>TECHNO-COMMERCIAL CHECKLIST</u>						
SL. NO.	TERMS & CONDITION					VENDOR CONFIRMATION /REMARKS / REPLY
TENDER DETAILS						
1	BIDDER NAME					
2	GEM BID NO					
QUALITY & TECHNICAL REQUIREMENTS						
3	ALL VENDORS TO PROVIDE POINT WISE REPLY/CONFIRMATION ALONG WITH RELEVANT SUPPORTING DOCUMENTS TO EACH AND EVERY POINT OF PRE-QUALIFICATION REQUIREMENT/PQR FOR ALL ENQUIRY ITEMS. NONCOMPLIANCE OF THESE MAY LEAD TO REJECTION OF OFFER AS THESE ARE ESSENTIAL CONDITION FOR PARTICIPATING IN TENDER ENQUIRY.					
4	KINDLY UPLOAD/ATTACH THE SPECIFICATION DETAILS/ CATALOGUE OF OFFERED ITEMS. (IF APPLICABLE)					
5	VENDOR TO CONFIRM TO PROVIDE TEST CERTIFICATES AS PER MANUFACTURER'S STANDARD PRACTICE.					
6	VENDOR TO CONFIRM TO PROVIDE ALL TECHNICAL PARAMETERS OF ITEM INCLUDING MANUFACTURER SERIAL NO. IN TEST CERTIFICATES AS WELL AS ON THE ITEM.					
7	VENDOR TO CONFIRM TO PROVIDE INTERNAL RECORDS FOR ARMATURE COATING OF HORN.					
8	VENDOR TO CONFIRM TO MENTION CURE DATE & SHELF LIFE OF O-RINGS USED IN KALXON HORN IN T.C. AS WELL AS ON THE ITEM.					
9	VENDOR TO CONFIRM TO PROVIDE PACKING LIST OF ITEMS DURING DISPATCH (COVERING MAIN AND SPARES ITEMS OF KLAXON HORN). ALSO, KLAXON HORN SHALL BE IN ASSEMBLED CONDITION WITH CABLE GLAND AND CONNECTING CABLE (0.5 METER) IN LINE WITH SPECIFICATION DPE/TS/KH-110V60 AND VENDOR TO INSPECT THE SAME AND MENTION SAME IN TEST CERTIFICATES.					
10	VENDOR TO CONFIRM TO PROVIDE DOCUMENTS KEEP PROPER CORRELATION WITH PO ITEMS AND THEIR QUANTITY.					
11	VENDOR TO CONFIRM TO PROVIDE CERTIFICATE OF CONFORMANCE ALONG WITH MATERIAL DISPATCH.					
COMMERICAL REMARKS						
10	VENDOR TO CONFIRM DELIVERY SCHEDULE AS PER TABLE:					
	SLN	MAT CODE	QUANTITY (NOS.)	Lot No.	Lot Qty.	Dly. Schedule
	1	W97057701080	52	1	2	30.09.2024
	2	W97057701080_1		2	24	30.03.2025
3	W97057701080_2	3		26	30.03.2026	
11	1. EARLY DELIVERY IS ACCEPTABLE FOR LOT 1. 2. EARLY DELIVERY IS ACCEPTABLE FROM JAN' 2025 (FOR LOT-2). 3. EARLY DELIVERY IS ACCEPTABLE FROM JAN' 2026 (FOR LOT-3).					
12	KINDLY SUBMIT MAKE IN INDIA SELF CERTIFICATION AS PER FORMAT GIVEN ALONG WITH THE ENQUIRY					

13	<p>BREACH OF CONTRACT CLAUSE: IN CASE OF BREACH OF CONTRACT, WHEREVER THE VALUE OF SECURITY INSTRUMENTS LIKE PERFORMANCE BANK GUARANTEE AVAILABLE WITH BHEL AGAINST THE SAID CONTRACT IS ATLEAST 10% OF THE CONTRACT VALUE, THE SAME BE ENCASHED. IN CASE THE VALUE OF THE SECURITY INSTRUMENTS AVAILABLE IS LESS THAN 10% OF THE CONTRACT VALUE, THE BALANCE AMOUNT BE RECOVERED FROM OTHER FINANCIAL REMEDIES (I.E. AVAILABLE BILLS OF THE CONTRACTOR, RETENTION AMOUNT, ETC. WITH BHEL) OR LEGAL REMEDIES BE PURSUED.</p>	
14	<p>ACTION AGAINST BIDDERS / VENDOR / SUPPLIER / CONTRACTOR IN CASE OF DEFAULT: IN ORDER TO PROTECT THE COMMERCIAL INTERESTS OF BHEL, BHEL SHALL TAKE ACTION AGAINST SUPPLIES / CONTRACTORS BY WAY OF SUSPENSION OF BUSINESS DEALINGS, WHO EITHER FAIL TO PERFORM OR ARE IN DEFAULT WITHOUT ANY REASONABLE CAUSE, CAUSE LOSS OF BUSINESS/ MONEY/ REPUTATION, INDULGE IN MALPRACTICES, CHEATING, BRIBERY, FRAUD OR ANY OTHER MISCONDUCT OR FORMATION OF CARTELS SO AS TO INFLUENCE THE BIDDING PROCESS OR INFLUENCE THE PRICE ETC. SUSPENSION OF BUSINESS DEALINGS COULD BE IN THE FORM OF “HOLD” OR “BANNING” A SUPPLIER/ CONTRACTOR OR A BIDDER AND SHALL BE AS PER “GUIDELINES FOR SUSPENSION OF BUSINESS DEALINGS WITH SUPPLIERS/ CONTRACTORS” AVAILABLE AT BHEL’S WEBSITE “https://www.bhel.com/guidelines-suspension-business-dealings-supplierscontractors”</p>	
15	REST GENERAL TERMS AND CONDITIONS AS PER GeM	

MAKE IN INDIA SELF CERTIFICATION

As per Government Public procurement order no. P-45021/2/2017-BE-II dt.15.06.2017 & P45021/2/2017-PP(BE-II) dated 28.05.2018,29.5.2019, 04.6.2020 and amendment dated 16.09.2020, it is hereby certifying that we

.....
..... (supplier name) are(Class-I/Class-II)
local supplier and will meet the requirement of minimum local content of
(50%/20%) as defined in public procurement order dated 04.6.2020 for material against Enquiry no.
..... Details of
location at which local value addition will be made is as follows: -
.....
.....
.....

We also understand, false declarations will be in breach of the code of integrity under Rule 175(1)(i)(h) of the General Financial Rules for which a bidder or its successors can be debarred for up to two years as per Rule 151 (iii) of the general financial rules along with such other actions as may be permissible under law.

Note:

As per office order P-45021/102/2019-BE-II-Part (1) (E-50310) Dated 04/03/2021, Bidders can't claim itself as "Class-I local supplier/Class-II local suppliers" by claiming the service such as transportation, insurance, installation, commissioning, training & after sales service support like AMC/CMC etc. as local value addition. Bidder offering imported product will fall under the category of Non-Local supplier.

BID SPECIFIC TERMS AND CONDITIONS

1. ALL VENDORS TO PROVIDE POINT WISE REPLY/CONFIRMATION ALONG WITH RELEVANT SUPPORTING DOCUMENTS TO EACH AND EVERY POINT OF **PRE-QUALIFICATION REQUIREMENT/PQR** FOR ALL ENQUIRY ITEMS. NONCOMPLIANCE OF THESE MAY LEAD TO REJECTION OF OFFER AS THESE ARE ESSENTIAL CONDITION FOR PARTICIPATING IN TENDER ENQUIRY.
2. DELIVERY SHALL BE IN STAGGERED MANNER AS PER BELOW TABLE:

SLN	MAT CODE	ITEM DISCREPTION	TOTAL QUANTITY (NOS.)	LOT	LOT QTY (NOS.)	DELIVERY. SCHEDULE
1	W97057701080	KLAXON HORN 110VAC, 60HZ,120DB AS PER SPECIFICATION NO. DPE/TS/KH-110V60 N.STD:- SIZE: KHRR10103	52	1 ST	2	30.09.2024
2	W97057701080_1	KLAXON HORN 110VAC, 60HZ,120DB AS PER SPECIFICATION NO. DPE/TS/KH-110V60 N.STD:- SIZE: KHRR10103		2 ND	24	30.03.2025
3	W97057701080_2	KLAXON HORN 110VAC, 60HZ,120DB AS PER SPECIFICATION NO. DPE/TS/KH-110V60 N.STD:- SIZE: KHRR10103		3 rd	26	30.03.2026

3. EARLY DELIVERY IS ACCEPTABLE FOR LOT 1.
4. EARLY DELIVERY IS ACCEPTABLE FROM JAN' 2025 (FOR LOT-2).
5. EARLY DELIVERY IS ACCEPTABLE FROM JAN' 2026 (FOR LOT-3).
6. ALL VENDORS TO PROVIDE POINT WISE REPLY/CONFIRMATION ALONG WITH RELEVANT SUPPORTING DOCUMENTS TO EACH AND EVERY POINT OF **PRE-QUALIFICATION REQUIREMENT/PQR** FOR ALL ENQUIRY ITEMS. NONCOMPLIANCE OF THESE MAY LEAD TO REJECTION OF OFFER AS THESE ARE ESSENTIAL CONDITION FOR PARTICIPATING IN TENDER ENQUIRY.
7. KINDLY UPLOAD/ATTACH THE SPECIFICATION DETAILS/ CATALOGUE OF OFFERED ITEMS.
8. KINDLY **SUBMIT TECHNO-COMMERCIAL CHECKLIST** ALONG WITH YOUR OFFER.
9. VENDOR TO CONFIRM TO PROVIDE TEST CERTIFICATES AS PER MANUFACTURER'S STANDARD PRACTICE.
10. VENDOR TO CONFIRM TO PROVIDE ALL TECHNICAL PARAMETERS OF ITEM INCLUDING MANUFACTURER SERIAL NO. IN TEST CERTIFICATES AS WELL AS ON THE ITEM.
11. VENDOR TO CONFIRM TO PROVIDE INTERNAL RECORDS FOR ARMATURE COATING OF HORN.
12. VENDOR TO CONFIRM TO MENTION CURE DATE & SHELF LIFE OF O-RINGS USED IN KALXON HORN IN T.C. AS WELL AS ON THE ITEM.
13. VENDOR TO CONFIRM TO PROVIDE PACKING LIST OF ITEMS DURING DISPATCH (COVERING MAIN AND SPARES ITEMS OF KLAXON HORN). ALSO, KLAXON HORN SHALL BE IN ASSEMBLED CONDITION WITH CABLE GLAND AND CONNECTING CABLE (0.5 METER) IN LINE WITH SPECIFICATION DPE/TS/KH-110V60 AND VENDOR TO INSPECT THE SAME AND MENTION SAME IN TEST CERTIFICATES.

14. VENDOR TO CONFIRM TO PROVIDE DOCUMENTS KEEP PROPER CORRELATION WITH PO ITEMS AND THEIR QUANTITY.
15. VENDOR TO CONFIRM TO PROVIDE CERTIFICATE OF CONFORMANCE ALONG WITH MATERIAL DISPATCH.
16. VENDOR TO SUBMIT MAKE IN INDIA SELF CERTIFICATION AS PER FORMAT GIVEN ALONG WITH THE ENQUIRY
17. MSE/MII: THE SUPPLIER NEEDS TO SUBMIT/UPDATE MSE/MII CREDENTIALS ON GEM PORTAL DURING PROFILE UPDATION/ OFFER SUBMISSION STAGE. THE MSE DATA SUBMITTED IS CROSS VERIFIED BY GEM WITH GOVT. OF INDIA UDYAM/NSIC DATABASE THROUGH API INTEGRATION ON REAL TIME BASIS AND FOR MII, A SELF DECLARATION IS BEING GIVEN AND AUTHENTICATED BY AADHAR OTP. IF THE SELLER FAILS TO CLAIM MSE/MII PROVISION ON GEM PORTAL AT PROFILE UPDATION/BID SUBMISSION STAGE, THE SAID SELLER WILL BECOME INELIGIBLE FOR GETTING THE MSE/MII BENEFITS FOR THAT BID AUTOMATICALLY. THE VENDOR CAN ALWAYS CONTACT THE GEM HELPDESK, IN CASE OF ANY ISSUES.
18. IF PRICE QUOTED BY MSE VENDOR IS WITHIN THE PRICE BAND OF L1+15%, THEN 25% QUANTITY OF THE RESPECTIVE ITEM (ROUNDED OFF TO NEAREST NUMBER) SHALL BE OFFERED TO MSE VENDOR SUBJECT TO MATCHING THE L1 PRICES.
19. IF THE QUANTITY REQUIRED IS 1 NUMBER (AS SUCH NON-DIVISIBLE), MSE QUOTING WITH IN PRICE PREFERENCE OF L1+15% SHALL BE OFFERED 100% QUANTITY SUBJECT TO MATCHING THE L1 PRICES
20. THE PRICE QUOTE BY BIDDER SHOULD BE INCLUSIVE OF GST & SHOULD BE ON BHEL HEEP HARIDWAR STORES BASIS.
21. BIDDER'S OFFER IS LIABLE TO BE REJECTED IF THEY DON'T UPLOAD ANY OF THE CERTIFICATES / DOCUMENTS SOUGHT IN THE BID DOCUMENT, ATC AND CORRIGENDUM IF ANY.

22. BREACH OF CONTRACT CLAUSE:

IN CASE OF BREACH OF CONTRACT, WHEREVER THE VALUE OF SECURITY INSTRUMENTS LIKE PERFORMANCE BANK GUARANTEE AVAILABLE WITH BHEL AGAINST THE SAID CONTRACT IS ATLEAST 10% OF THE CONTRACT VALUE, THE SAME BE ENCASHED. IN CASE THE VALUE OF THE SECURITY INSTRUMENTS AVAILABLE IS LESS THAN 10% OF THE CONTRACT VALUE, THE BALANCE AMOUNT BE RECOVERED FROM OTHER FINANCIAL REMEDIES (I.E. AVAILABLE BILLS OF THE CONTRACTOR, RETENTION AMOUNT, ETC. WITH BHEL) OR LEGAL REMEDIES BE PURSUED.

23. ACTION AGAINST BIDDERS / VENDOR / SUPPLIER / CONTRACTOR IN CASE OF DEFAULT:

IN ORDER TO PROTECT THE COMMERCIAL INTERESTS OF BHEL, BHEL SHALL TAKE ACTION AGAINST SUPPLIES / CONTRACTORS BY WAY OF SUSPENSION OF BUSINESS DEALINGS, WHO EITHER FAIL TO PERFORM OR ARE IN DEFAULT WITHOUT ANY REASONABLE CAUSE, CAUSE LOSS OF BUSINESS/ MONEY/ REPUTATION, INDULGE IN MALPRACTICES, CHEATING, BRIBERY, FRAUD OR ANY OTHER MISCONDUCT OR FORMATION OF CARTELS SO AS TO INFLUENCE THE BIDDING PROCESS OR INFLUENCE THE PRICE ETC.

SUSPENSION OF BUSINESS DEALINGS COULD BE IN THE FORM OF "HOLD" OR "BANNING" A SUPPLIER/ CONTRACTOR OR A BIDDER AND SHALL BE AS PER "GUIDELINES FOR SUSPENSION OF BUSINESS DEALINGS WITH SUPPLIERS/ CONTRACTORS" AVAILABLE AT BHEL'S WEBSITE <https://www.bhel.com/guidelines-suspension-business-dealings-supplierscontractors>

24. BIDDERS ARE ADVISED TO CHECK APPLICABLE GST ON THEIR OWN BEFORE QUOTING. BUYER WILL NOT TAKE ANY RESPONSIBILITY IN THIS REGARDS. GST REIMBURSEMENT WILL BE AS PER ACTUALS OR AS PER APPLICABLE RATES (WHICHEVER IS LOWER), SUBJECT TO THE MAXIMUM OF QUOTED GST %.
25. BIDDER SHALL SUBMIT THE FOLLOWING DOCUMENTS ALONG WITH THEIR BID FOR VENDOR CODE CREATION:

A. COPY OF PAN CARD B. COPY OF GSTIN C. COPY OF MSE CERIFICATE

26. DEDICATED /TOLL FREE TELEPHONE NO. FOR SERVICE SUPPORT: BIDDER/OEM MUST HAVE DEDICATED/TOLL FREE TELEPHONE NO. FOR SERVICE SUPPORT.
27. DATA SHEET OF THE PRODUCT(S) OFFERED IN THE BID, ARE TO BE UPLOADED ALONG WITH THE BID DOCUMENTS. BUYERS CAN MATCH AND VERIFY THE DATA SHEET WITH THE PRODUCT SPECIFICATIONS OFFERED. IN CASE OF ANY UNEXPLAINED MISMATCH OF TECHNICAL PARAMETERS, THE BID IS LIABLE FOR REJECTION.
28. SCOPE OF SUPPLY (BID PRICE TO INCLUDE ALL COST COMPONENTS): ONLY SUPPLY OF GOODS.
29. PRODUCTS SUPPLIED SHALL BE NONTOXIC AND HARMLESS TO HEALTH. IN THE CASE OF TOXIC MATERIALS, MATERIAL SAFETY DATA SHEET MAY BE FURNISHED ALONG WITH THE MATERIAL.
30. WHILE GENERATING INVOICE IN GEM PORTAL, THE SELLER MUST UPLOAD SCANNED COPY OF GST INVOICE AND THE SCREENSHOT OF GST PORTAL CONFIRMING PAYMENT OF GST.
31. **PAYMENT TERMS SHALL BE AS PER FOLLOWINGS:**
- a) **FOR NON-MSES BIDDER:** 100% payment along with taxes, freight & insurance will be made after receipt and acceptance of material and within 90 days from the date of invoice subject to submission of non-discrepant documents within 15 days of supply as per terms and conditions of Purchase Order (THIS IS IN SUPERSESSION OF 10 DAYS' TIME AS PROVIDED IN CLAUSE 12 OF GEM GTC).
- b) **FOR MSES BIDDER:** For MSEs (covered under MSME Act) which are registered and periodically renewed with BHEL, the payment will be made within 45 days or as prescribed in the relevant act. Benefits of MSE (such as EMD Waiver, Tender fee exemption, Price preference, Payment preference etc.) will be given only to those MSE Vendors who are manufacturers of offered items against the NIT. No MSE benefits shall be provided to Agents / Stockists /Dealers / Traders etc. for the items offered but not manufactured by themselves.”
- c) **FOR MEDIUM ENTERPRISES:** 100% payment along with taxes, freight & insurance will be made after receipt and acceptance of material and within 60 days from the date of invoice subject to submission of non-discrepant documents within 15 days of supply as per terms and conditions of Purchase Order.
- d) Please note that vendor to adhere to the payment terms as per above. No deviation in payment terms shall be accepted. Vendor to submit their offer accordingly.