



REQUIREMENT OF CABLE CLAMP

The Heavy Electricals Equipment Plant (HEEP) located in Haridwar, India is one of the major manufacturing plants of Bharat Heavy Electricals Ltd. The core business of HEEP includes design and manufacture of large steam and gas turbines, turbo generators, Defense Items and so on.

Details of items details as below:

SLN	MAT CODE	ITEM DISCREPTION	Quantity (Nos)	Delivery (Days)
1	W97031701090	CLAMP, CABLE, MS21919-DG8 N.STD:MS21919 SIZE: P/N 137618181	40	90
2	W97031701104	CLAMP, CABLE, MS21919-DG6 N.STD:MS21919 SIZE: P/N 127619284	40	90
3	W97031701120	CLAMP, CABLE MS 21919-DG4 N.STD:MS21919	50	90
4	W97031701139	CLAMP, CABLE MS 21919-DG12 N.STD:MS21919	50	90
5	W97031701147	CABLE CLAMP MS 21104-D13 ALTERNATE: MS21919-DG13 N.STD:MS21919	60	90
6	W97031701155	CLAMP, CABLE MS 21919-DG18 N.STD:MS21919	30	90
7	W97031701163	CLAMP, CABLE MS 21919-DG20 N.STD:MS21919	30	90
8	W97031701171	CLAMP, CABLE MS 21919-DG25 N.STD:MS21919	30	90

1. ALL VENDORS TO PROVIDE POINT WISE REPLY/CONFIRMATION ALONG WITH RELEVANT SUPPORTING DOCUMENTS TO EACH AND EVERY POINT OF PRE-QUALIFICATION REQUIREMENT/PQR FOR ALL ENQUIRY ITEMS. NONCOMPLIANCE OF THESE MAY LEAD TO REJECTION OF OFFER AS THESE ARE ESSENTIAL CONDITION FOR PARTICIPATING IN TENDER ENQUIRY
2. KINDLY UPLOAD/ATTACH THE SPECIFICATION DETAILS/ CATALOGUE OF OFFERED ITEMS.
3. KINDLY ARRANGE TO **SUBMIT TECHNO-COMMERCIAL CHECKLIST** ALONG WITH YOUR OFFER.
4. VENDOR TO CONFIRM TO PROVIDE MATERIAL & DIMENSIONAL TEST CERTIFICATES OF THE MATERIALS ALONG WITH MATERIAL DISPATCH.
5. VENDOR TO CONFIRM TO PROVIDE DOCUMENTS KEEP PROPER CORRELATION WITH PO ITEMS AND THEIR QUANTITY.
6. VENDOR TO CONFIRM TO PROVIDE CERTIFICATE OF CONFORMANCE
7. VENDOR TO CONFIRM TO PROVIDE NON REMOVABLE IDENTIFICATION ON ITEMS OR PACKING AND PROVIDE REPORT ACCORDINGLY

QUALIFYING CONDITIONS for CABLE CLAMPS as per MS21919

Sl.	PQR Requirement	Vendor Response	Vendor Response (Yes / No / Enclosed)
1.	Vendor, who can manufacture or supply Military Grade CABLE CLAMPS as per MS21919	Vendor to confirm	
2.	who can provide Technical Datasheet along with supplies	Vendor to confirm	
3.	who can provide Certificate of Conformance (COC) <i>(also known as Certificate of Conformity or Certificate of Compliance)</i>	Vendor to confirm	
4.	<i>Point numbers 1 to 3 are the Mandatory Qualification Requirements. Offers of vendors not meeting these requirements will NOT be considered.</i>	Vendor to accept & confirm	

TECHNICAL PARAMETERS CHECK LIST
DATA VALUES TO BE FILLED AND CONFIRMED BY VENDOR

ITEM CODE W97031701090
 ITEM NAME CLAMP, CABLE, MS21919-DG8
 ITEM PART NO P/N 137618181
 INTERNATIONAL EQUIVALENT MS21919-DG8

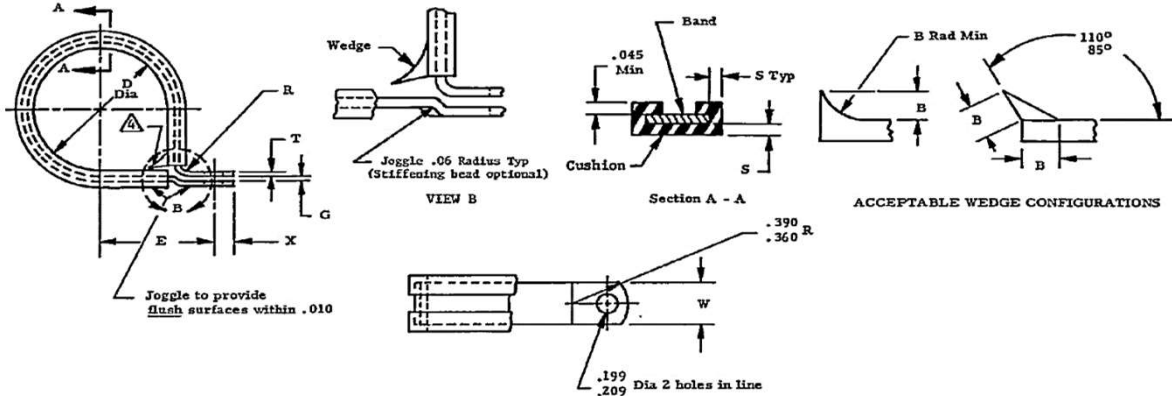

SN.	PARAMETERS	VALUES	UNIT	RESPONSE TYPE	VENDOR RESPONSE
1	SPECIFICATION	MS21919	-	To confirm →	
2	DASH NO	8	-	To confirm →	
3	TYPE	CUSHIONED, WITHOUT WEDGE	-	To confirm →	
4	TUBE OUTER DIA (REF.)	1/2	INCH	Input Value →	
5	WEDGE SIZE (B)	0.093 (2.362) 0.125 (3.175)	IN (MM)	Input Value →	
6	INNER DIA (D)	0.500 (12.700) +/- 0.015 (.381)	IN (MM)	Input Value →	
7	HOLE DISTANCE (E)	0.654 (16.612) +/- 0.015 (.381)	IN (MM)	Input Value →	
8	CUSHION THICKNESS (S)	0.040 (1.016) +0.020 (.508) / -0.00	IN (MM)	Input Value →	
9	PLATE THICKNESS (T)	0.032 (.813)	IN (MM)	Input Value →	
10	PLATE WIDTH (W)	0.500 (12.700) +/- 0.010 (.254)	IN (MM)	Input Value →	
11	HOLE CENTRE DISTANCE (X)	0.188 (4.775) +/- 0.015 (.381)	IN (MM)	Input Value →	
12	PLATE MATERIAL	ALUMINIUM	-	To confirm →	
13	CUSHION MATERIAL	CHLOROPRENE (100 DEG.C)	-	To confirm →	
14	CUSHION COLOUR	BLACK	-	To confirm →	
15	CERTIFICATION	Certificate of Conformance / Compliance (COC)	Y	Confirm to supply →	
16	VENDOR REMARKS				

TECHNICAL PARAMETERS CHECK LIST
DATA VALUES TO BE FILLED AND CONFIRMED BY VENDOR

ITEM CODE W97031701104
 ITEM NAME CLAMP, CABLE, MS21919-DG6
 ITEM PART NO P/N 127619284
 INTERNATIONAL EQUIVALENT MS21919-DG6

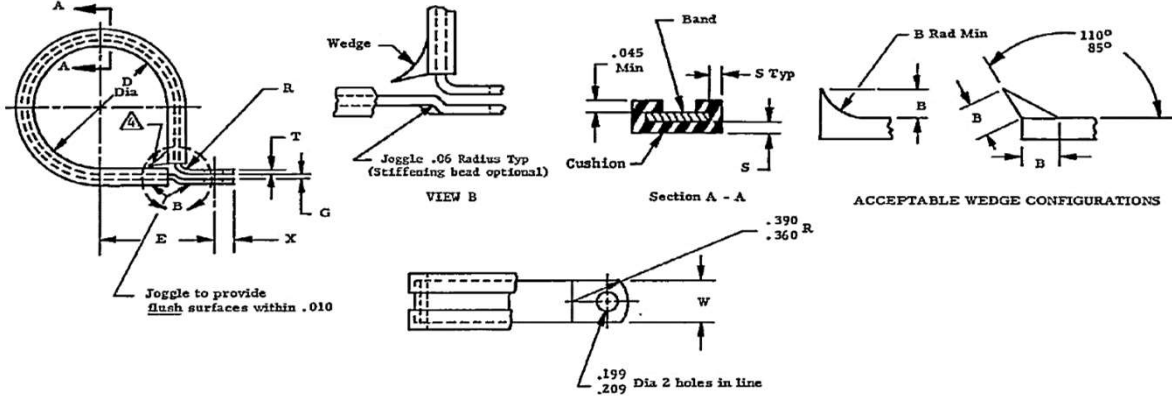

SN.	PARAMETERS	VALUES	UNIT	RESPONSE TYPE	VENDOR RESPONSE
1	SPECIFICATION	MS21919	-	To confirm →	
2	DASH NO	6	-	To confirm →	
3	TYPE	CUSHIONED, WITHOUT WEDGE	-	To confirm →	
4	TUBE OUTER DIA (REF.)	3/8	INCH	Input Value →	
5	WEDGE SIZE (B)	0.093 (2.362) 0.125 (3.175)	IN (MM)	Input Value →	
6	INNER DIA (D)	0.375 (9.525) +/- 0.015 (.381)	IN (MM)	Input Value →	
7	HOLE DISTANCE (E)	0.592 (15.037) +/- 0.015 (.381)	IN (MM)	Input Value →	
8	CUSHION THICKNESS (S)	0.040 (1.016) +0.020 (.508) / -0.00	IN (MM)	Input Value →	
9	PLATE THICKNESS (T)	0.032 (.813)	IN (MM)	Input Value →	
10	PLATE WIDTH (W)	0.500 (12.700) +/- 0.010 (.254)	IN (MM)	Input Value →	
11	HOLE CENTRE DISTANCE (X)	0.188 (4.775) +/- 0.015 (.381)	IN (MM)	Input Value →	
12	PLATE MATERIAL	ALUMINIUM	-	To confirm →	
13	CUSHION MATERIAL	CHLOROPRENE (100 DEG.C)	-	To confirm →	
14	CUSHION COLOUR	BLACK	-	To confirm →	
15	CERTIFICATION	Certificate of Conformance / Compliance (COC)	Y	Confirm to supply →	
16	VENDOR REMARKS				

TECHNICAL PARAMETERS CHECK LIST
DATA VALUES TO BE FILLED AND CONFIRMED BY VENDOR

ITEM CODE W97031701120
 ITEM NAME CLAMP, CABLE, MS21919-DG4
 ITEM PART NO -
 INTERNATIONAL EQUIVALENT MS21919-DG4

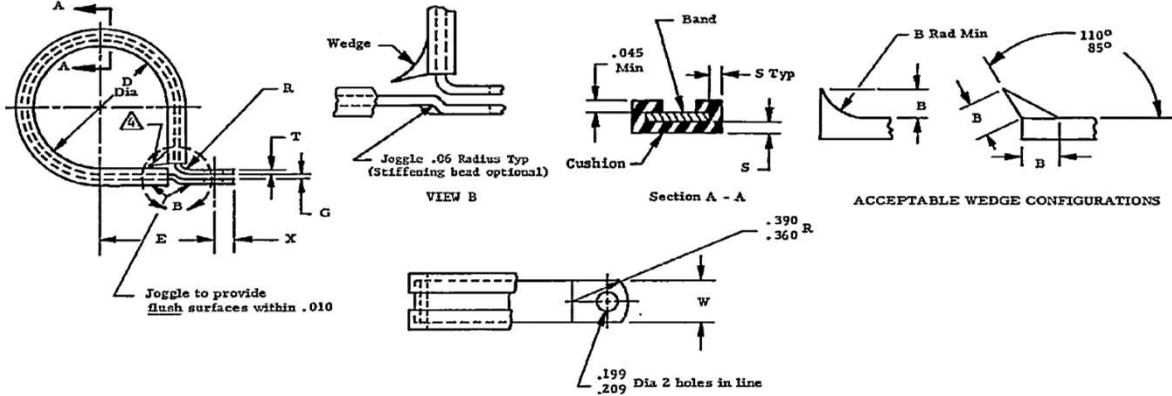

SN.	PARAMETERS	VALUES	UNIT	RESPONSE TYPE	VENDOR RESPONSE
1	SPECIFICATION	MS21919	-	To confirm →	
2	DASH NO	4	-	To confirm →	
3	TYPE	CUSHIONED, WITHOUT WEDGE	-	To confirm →	
4	TUBE OUTER DIA (REF.)	1/4	INCH	Input Value →	
5	WEDGE SIZE (B)	0.093 (2.362) 0.125 (3.175)	IN (MM)	Input Value →	
6	INNER DIA (D)	0.250 (6.350) +/- 0.015 (.381)	IN (MM)	Input Value →	
7	HOLE DISTANCE (E)	0.592 (15.037) +/- 0.015 (.381)	IN (MM)	Input Value →	
8	CUSHION THICKNESS (S)	0.040 (1.016) +0.020 (.508) / -0.00	IN (MM)	Input Value →	
9	PLATE THICKNESS (T)	0.032 (.813)	IN (MM)	Input Value →	
10	PLATE WIDTH (W)	0.500 (12.700) +/- 0.010 (.254)	IN (MM)	Input Value →	
11	HOLE CENTRE DISTANCE (X)	0.188 (4.775) +/- 0.015 (.381)	IN (MM)	Input Value →	
12	PLATE MATERIAL	ALUMINIUM	-	To confirm →	
13	CUSHION MATERIAL	CHLOROPRENE (100 DEG.C)	-	To confirm →	
14	CUSHION COLOUR	BLACK	-	To confirm →	
15	CERTIFICATION	Certificate of Conformance / Compliance (COC)	Y	Confirm to supply →	
16	VENDOR REMARKS				

TECHNICAL PARAMETERS CHECK LIST
DATA VALUES TO BE FILLED AND CONFIRMED BY VENDOR

ITEM CODE W97031701139
 ITEM NAME CLAMP, CABLE, MS21919-DG12
 ITEM PART NO -
 INTERNATIONAL EQUIVALENT MS21919-DG12

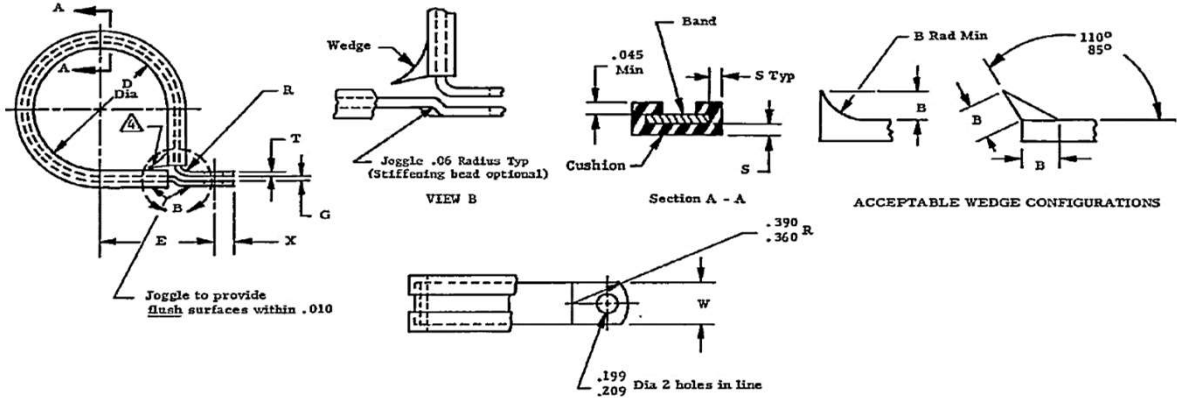

SN.	PARAMETERS	VALUES	UNIT	RESPONSE TYPE	VENDOR RESPONSE
1	SPECIFICATION	MS21919	-	To confirm →	
2	DASH NO	12	-	To confirm →	
3	TYPE	CUSHIONED, WITHOUT WEDGE	-	To confirm →	
4	TUBE OUTER DIA (REF.)	3/4	INCH	Input Value →	
5	WEDGE SIZE (B)	0.155 (3.937) 0.312 (7.925)	IN (MM)	Input Value →	
6	INNER DIA (D)	0.750 (19.050) +/- 0.015 (.381)	IN (MM)	Input Value →	
7	HOLE DISTANCE (E)	0.845 (21.463) +/- 0.015 (.381)	IN (MM)	Input Value →	
8	CUSHION THICKNESS (S)	0.040 (1.016) +0.020 (.508) / -0.00	IN (MM)	Input Value →	
9	PLATE THICKNESS (T)	0.050 (1.270)	IN (MM)	Input Value →	
10	PLATE WIDTH (W)	0.500 (12.700) +/- 0.010 (.254)	IN (MM)	Input Value →	
11	HOLE CENTRE DISTANCE (X)	0.218 (5.537) +/- 0.015 (.381)	IN (MM)	Input Value →	
12	PLATE MATERIAL	ALUMINIUM	-	To confirm →	
13	CUSHION MATERIAL	CHLOROPRENE (100 DEG.C)	-	To confirm →	
14	CUSHION COLOUR	BLACK	-	To confirm →	
15	CERTIFICATION	Certificate of Conformance / Compliance (COC)	Y	Confirm to supply →	
16	VENDOR REMARKS				

TECHNICAL PARAMETERS CHECK LIST
DATA VALUES TO BE FILLED AND CONFIRMED BY VENDOR

ITEM CODE W97031701147
 ITEM NAME CLAMP, CABLE, MS21919-DG13
 ITEM PART NO -
 INTERNATIONAL EQUIVALENT MS21919-DG13

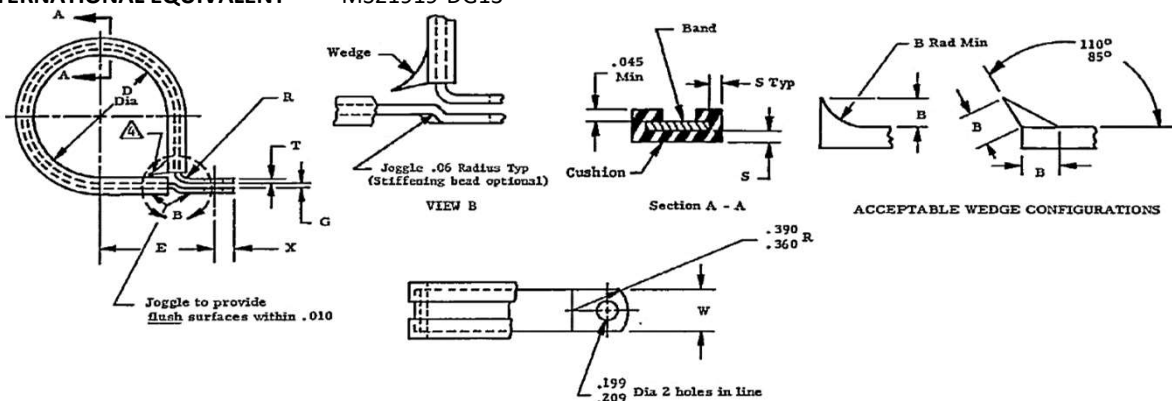

SN.	PARAMETERS	VALUES	UNIT	RESPONSE TYPE	VENDOR RESPONSE
1	SPECIFICATION	MS21919	-	To confirm →	
2	DASH NO	13	-	To confirm →	
3	TYPE	CUSHIONED, WITHOUT WEDGE	-	To confirm →	
4	TUBE OUTER DIA (REF.)	13/16	INCH	Input Value →	
5	WEDGE SIZE (B)	0.155 (3.937) 0.312 (7.925)	IN (MM)	Input Value →	
6	INNER DIA (D)	0.813 (20.650) +/- 0.015 (.381)	IN (MM)	Input Value →	
7	HOLE DISTANCE (E)	0.877 (22.276) +/- 0.015 (.381)	IN (MM)	Input Value →	
8	CUSHION THICKNESS (S)	0.040 (1.016) +0.020 (.508) / -0.00	IN (MM)	Input Value →	
9	PLATE THICKNESS (T)	0.050 (1.270)	IN (MM)	Input Value →	
10	PLATE WIDTH (W)	0.500 (12.700) +/- 0.010 (.254)	IN (MM)	Input Value →	
11	HOLE CENTRE DISTANCE (X)	0.218 (5.537) +/- 0.015 (.381)	IN (MM)	Input Value →	
12	PLATE MATERIAL	ALUMINIUM	-	To confirm →	
13	CUSHION MATERIAL	CHLOROPRENE (100 DEG.C)	-	To confirm →	
14	CUSHION COLOUR	BLACK	-	To confirm →	
15	CERTIFICATION	Certificate of Conformance / Compliance (COC)	Y	Confirm to supply →	
16	VENDOR REMARKS				

TECHNICAL PARAMETERS CHECK LIST
DATA VALUES TO BE FILLED AND CONFIRMED BY VENDOR

ITEM CODE W97031701155
 ITEM NAME CLAMP, CABLE, MS21919-DG18
 ITEM PART NO -
 INTERNATIONAL EQUIVALENT MS21919-DG18

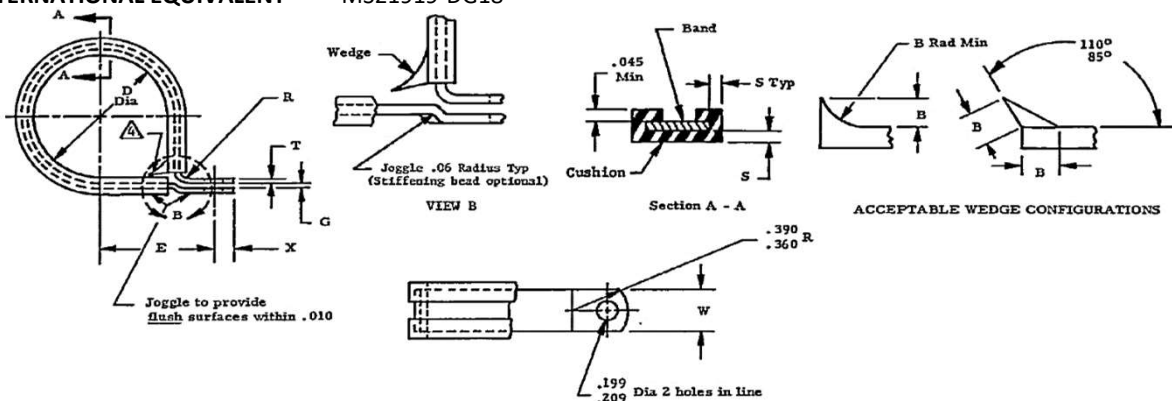

SN.	PARAMETERS	VALUES	UNIT	RESPONSE TYPE	VENDOR RESPONSE
1	SPECIFICATION	MS21919	-	To confirm →	
2	DASH NO	18	-	To confirm →	
3	TYPE	CUSHIONED, WITHOUT WEDGE	-	To confirm →	
4	TUBE OUTER DIA (REF.)	1 - 1/8	INCH	Input Value →	
5	WEDGE SIZE (B)	0.155 (3.937) 0.312 (7.925)	IN (MM)	Input Value →	
6	INNER DIA (D)	1.125 (28.575) +/- 0.015 (.381)	IN (MM)	Input Value →	
7	HOLE DISTANCE (E)	1.062 (26.975) +/- 0.015 (.381)	IN (MM)	Input Value →	
8	CUSHION THICKNESS (S)	0.060 (1.524) +/- 0.020 (.508)	IN (MM)	Input Value →	
9	PLATE THICKNESS (T)	0.062 (1.575)	IN (MM)	Input Value →	
10	PLATE WIDTH (W)	0.500 (12.700) +/- 0.010 (.254)	IN (MM)	Input Value →	
11	HOLE CENTRE DISTANCE (X)	0.218 (5.537) +/- 0.015 (.381)	IN (MM)	Input Value →	
12	PLATE MATERIAL	ALUMINIUM	-	To confirm →	
13	CUSHION MATERIAL	CHLOROPRENE (100 DEG.C)	-	To confirm →	
14	CUSHION COLOUR	BLACK	-	To confirm →	
15	CERTIFICATION	Certificate of Conformance / Compliance (COC)	Y	Confirm to supply →	
16	VENDOR REMARKS				

TECHNICAL PARAMETERS CHECK LIST
DATA VALUES TO BE FILLED AND CONFIRMED BY VENDOR

ITEM CODE W97031701163
 ITEM NAME CLAMP, CABLE, MS21919-DG20
 ITEM PART NO -
 INTERNATIONAL EQUIVALENT MS21919-DG20

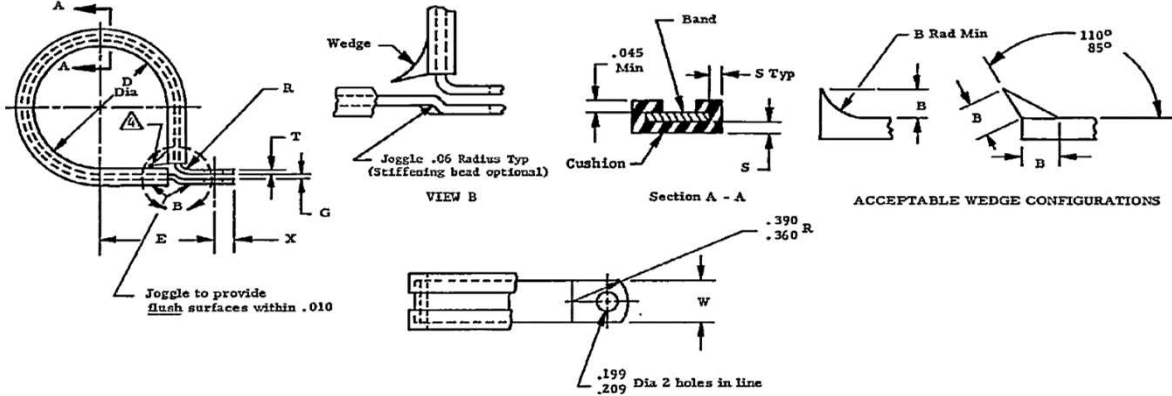

SN.	PARAMETERS	VALUES	UNIT	RESPONSE TYPE	VENDOR RESPONSE
1	SPECIFICATION	MS21919	-	To confirm →	
2	DASH NO	20	-	To confirm →	
3	TYPE	CUSHIONED, WITHOUT WEDGE	-	To confirm →	
4	TUBE OUTER DIA (REF.)	1 - 1/4	INCH	Input Value →	
5	WEDGE SIZE (B)	0.155 (3.937) 0.312 (7.925)	IN (MM)	Input Value →	
6	INNER DIA (D)	1.250 (31.750) +/- 0.015 (.381)	IN (MM)	Input Value →	
7	HOLE DISTANCE (E)	1.240 (31.496) +/- 0.015 (.381)	IN (MM)	Input Value →	
8	CUSHION THICKNESS (S)	0.060 (1.524) +/- 0.020 (.508)	IN (MM)	Input Value →	
9	PLATE THICKNESS (T)	0.062 (1.575)	IN (MM)	Input Value →	
10	PLATE WIDTH (W)	0.500 (12.700) +/- 0.010 (.254)	IN (MM)	Input Value →	
11	HOLE CENTRE DISTANCE (X)	0.218 (5.537) +/- 0.015 (.381)	IN (MM)	Input Value →	
12	PLATE MATERIAL	ALUMINIUM	-	To confirm →	
13	CUSHION MATERIAL	CHLOROPRENE (100 DEG.C)	-	To confirm →	
14	CUSHION COLOUR	BLACK	-	To confirm →	
15	CERTIFICATION	Certificate of Conformance / Compliance (COC)	Y	Confirm to supply →	
16	VENDOR REMARKS				

TECHNICAL PARAMETERS CHECK LIST
DATA VALUES TO BE FILLED AND CONFIRMED BY VENDOR

ITEM CODE W97031701171
 ITEM NAME CLAMP, CABLE, MS21919-DG25
 ITEM PART NO -
 INTERNATIONAL EQUIVALENT MS21919-DG25

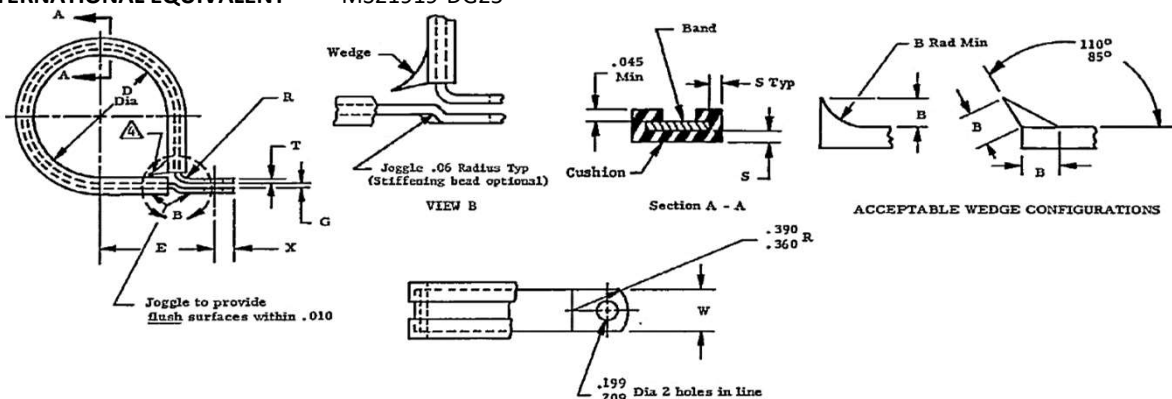

SN.	PARAMETERS	VALUES	UNIT	RESPONSE TYPE	VENDOR RESPONSE
1	SPECIFICATION	MS21919	-	To confirm →	
2	DASH NO	25	-	To confirm →	
3	TYPE	CUSHIONED, WITHOUT WEDGE	-	To confirm →	
4	TUBE OUTER DIA (REF.)	1 - 9/16	INCH	Input Value →	
5	WEDGE SIZE (B)	0.155 (3.937) 0.312 (7.925)	IN (MM)	Input Value →	
6	INNER DIA (D)	1.563 (39.700) +/- 0.015 (.381)	IN (MM)	Input Value →	
7	HOLE DISTANCE (E)	1.281 (32.537) +/- 0.015 (.381)	IN (MM)	Input Value →	
8	CUSHION THICKNESS (S)	0.060 (1.524) +/- 0.020 (.508)	IN (MM)	Input Value →	
9	PLATE THICKNESS (T)	0.062 (1.575)	IN (MM)	Input Value →	
10	PLATE WIDTH (W)	0.500 (12.700) +/- 0.010 (.254)	IN (MM)	Input Value →	
11	HOLE CENTRE DISTANCE (X)	0.218 (5.537) +/- 0.015 (.381)	IN (MM)	Input Value →	
12	PLATE MATERIAL	ALUMINIUM	-	To confirm →	
13	CUSHION MATERIAL	CHLOROPRENE (100 DEG.C)	-	To confirm →	
14	CUSHION COLOUR	BLACK	-	To confirm →	
15	CERTIFICATION	Certificate of Conformance / Compliance (COC)	Y	Confirm to supply →	
16	VENDOR REMARKS				

TECHNO-COMMERCIAL CHECKLIST

SL. NO.	TERMS & CONDITION	VENDOR CONFIRMATION /REMARKS / REPLY
1	BIDDER NAME	
2	GEM BID NO	
3	ITEM IS TO BE SUPPLIED AS PER TECHNICAL SPECIFICATION	
4	ALL VENDORS TO PROVIDE POINT WISE REPLY/CONFIRMATION ALONG WITH RELEVANT SUPPORTING DOCUMENTS TO EACH AND EVERY POINT OF PRE-QUALIFICATION REQUIREMENT/PQR FOR ALL ENQUIRY ITEMS. NONCOMPLIANCE OF THESE MAY LEAD TO REJECTION OF OFFER AS THESE ARE ESSENTIAL CONDITION FOR PARTICIPATING IN TENDER ENQUIRY	
5	KINDLY UPLOAD/ATTACH THE SPECIFICATION DETAILS/ CATALOGUE OF OFFERED ITEMS.	
6	VENDOR TO CONFIRM TO PROVIDE MATERIAL & DIMENSIONAL TEST CERTIFICATES OF THE MATERIALS ALONG WITH MATERIAL DISPATCH	
7	VENDOR TO CONFIRM TO PROVIDE DOCUMENTS KEEP PROPER CORRELATION WITH PO ITEMS AND THEIR QUANTITY.	
8	VENDOR TO CONFIRM TO PROVIDE CERTIFICATE OF CONFORMANCE	
9	VENDOR TO CONFIRM TO PROVIDE NON REMOVABLE IDENTIFICATION ON ITEMS OR PACKING AND PROVIDE REPORT ACCORDINGLY	
10	<p>RISK PURCHASE: IN CASE OF ABNORMAL DELAYS (BEYOND THE MAXIMUM LATE DELIVERY PERIOD AS PER LD CLAUSE) IN SUPPLIES / DEFECTIVE SUPPLIES OR NONFULFILLMENT OF ANY OTHER TERMS AND CONDITIONS GIVEN IN PURCHASE ORDER, BHEL MAY CANCEL THE PURCHASE ORDER IN FULL OR PART THEREOF, AND MAY ALSO MAKE THE PURCHASE OF SUCH MATERIAL FROM ELSEWHERE / ALTERNATIVE SOURCE AT THE RISK AND COST OF THE SUPPLIER. BHEL WILL TAKE ALL REASONABLE STEPS TO GET THE MATERIAL FROM ALTERNATE SOURCE AT OPTIMUM COST. IF BIDDER DOES NOT AGREE TO THE ABOVE RISK PURCHASE CLAUSE, BHEL RESERVES THE RIGHT TO REJECT THE OFFER. IN CASE FOR COMPELLING REASONS BHEL ACCEPTS THE OFFER WITHOUT ACCEPTANCE OF THIS CLAUSE BY THE BIDDER AND IN THE EVENTUALITY OF RISK PURCHASE, APPROPRIATE ACTION WILL BE TAKEN AS PER BHEL EXTANT RULES. THIS WILL BE WITHOUT PREJUDICE TO ANY OTHER RIGHT OF BHEL UNDER THE CONTRACT OR UNDER GENERAL LAW.</p>	
11	<p>ACTION AGAINST BIDDERS / VENDOR / SUPPLIER / CONTRACTOR IN CASE OF DEFAULT: IN ORDER TO PROTECT THE COMMERCIAL INTERESTS OF BHEL, BHEL SHALL TAKE ACTION AGAINST SUPPLIES / CONTRACTORS BY WAY OF SUSPENSION OF BUSINESS DEALINGS, WHO EITHER FAIL TO PERFORM OR ARE IN DEFAULT WITHOUT ANY REASONABLE CAUSE, CAUSE LOSS OF BUSINESS/ MONEY/ REPUTATION, INDULGE IN MALPRACTICES, CHEATING, BRIBERY, FRAUD OR ANY OTHER MISCONDUCT OR FORMATION OF CARTELS SO AS TO INFLUENCE THE BIDDING PROCESS OR INFLUENCE THE PRICE ETC.</p> <p>SUSPENSION OF BUSINESS DEALINGS COULD BE IN THE FORM OF “HOLD” OR “BANNING” A SUPPLIER/ CONTRACTOR OR A BIDDER AND SHALL BE AS PER “GUIDELINES FOR SUSPENSION OF BUSINESS DEALINGS WITH SUPPLIERS/ CONTRACTORS” AVAILABLE AT BHEL’S WEBSITE “https://www.bhel.com/guidelines-suspension-business-dealings-supplierscontractors”</p>	

1. ALL VENDORS TO PROVIDE POINT WISE REPLY/CONFIRMATION ALONG WITH RELEVANT SUPPORTING DOCUMENTS TO EACH AND EVERY POINT OF PRE-QUALIFICATION REQUIREMENT/PQR FOR ALL ENQUIRY ITEMS. NONCOMPLIANCE OF THESE MAY LEAD TO REJECTION OF OFFER AS THESE ARE ESSENTIAL CONDITION FOR PARTICIPATING IN TENDER ENQUIRY
2. KINDLY UPLOAD/ATTACH THE SPECIFICATION DETAILS/ CATALOGUE OF OFFERED ITEMS.
3. KINDLY ARRANGE TO **SUBMIT TECHNO-COMMERCIAL CHECKLIST** ALONG WITH YOUR OFFER.
4. VENDOR TO CONFIRM TO PROVIDE MATERIAL & DIMENSIONAL TEST CERTIFICATES OF THE MATERIALS ALONG WITH MATERIAL DISPATCH.
5. VENDOR TO CONFIRM TO PROVIDE DOCUMENTS KEEP PROPER CORRELATION WITH PO ITEMS AND THEIR QUANTITY.
6. VENDOR TO CONFIRM TO PROVIDE CERTIFICATE OF CONFORMANCE.
7. VENDOR TO CONFIRM TO PROVIDE NON REMOVABLE IDENTIFICATION ON ITEMS OR PACKING AND PROVIDE REPORT ACCORDINGLY
8. MSE/MII: THE SUPPLIER NEEDS TO SUBMIT/UPDATE MSE/MII CREDENTIALS ON GEM PORTAL DURING PROFILE UPDATION/ OFFER SUBMISSION STAGE. THE MSE DATA SUBMITTED IS CROSS VERIFIED BY GEM WITH GOVT. OF INDIA UDYAM/NSIC DATABASE THROUGH API INTEGRATION ON REAL TIME BASIS AND FOR MII, A SELF DECLARATION IS BEING GIVEN AND AUTHENTICATED BY AADHAR OTP. IF THE SELLER FAILS TO CLAIM MSE/MII PROVISION ON GEM PORTAL AT PROFILE UPDATION/BID SUBMISSION STAGE, THE SAID SELLER WILL BECOME INELIGIBLE FOR GETTING THE MSE/MII BENEFITS FOR THAT BID AUTOMATICALLY. THE VENDOR CAN ALWAYS CONTACT THE GEM HELPDESK, IN CASE OF ANY ISSUES.
9. THE PRICE QUOTE BY BIDDER SHOULD BE INCLUSIVE OF GST & SHOULD BE ON BHEL HEEP HARIDWAR STORES BASIS.
10. BIDDER'S OFFER IS LIABLE TO BE REJECTED IF THEY DON'T UPLOAD ANY OF THE CERTIFICATES / DOCUMENTS SOUGHT IN THE BID DOCUMENT, ATC AND CORRIGENDUM IF ANY.
11. **RISK PURCHASE:** IN CASE OF ABNORMAL DELAYS (BEYOND THE MAXIMUM LATE DELIVERY PERIOD AS PER LD CLAUSE) IN SUPPLIES / DEFECTIVE SUPPLIES OR NONFULFILLMENT OF ANY OTHER TERMS AND CONDITIONS GIVEN IN PURCHASE ORDER, BHEL MAY CANCEL THE PURCHASE ORDER IN FULL OR PART THEREOF, AND MAY ALSO MAKE THE PURCHASE OF SUCH MATERIAL FROM ELSEWHERE / ALTERNATIVE SOURCE AT THE RISK AND COST OF THE SUPPLIER. BHEL WILL TAKE ALL REASONABLE STEPS TO GET THE MATERIAL FROM ALTERNATE SOURCE AT OPTIMUM COST. IF BIDDER DOES NOT AGREE TO THE ABOVE RISK PURCHASE CLAUSE, BHEL RESERVES THE RIGHT TO REJECT THE OFFER. IN CASE FOR COMPELLING REASONS BHEL ACCEPTS THE OFFER WITHOUT ACCEPTANCE OF THIS CLAUSE BY THE BIDDER AND IN THE EVENTUALITY OF RISK PURCHASE, APPROPRIATE ACTION WILL BE TAKEN AS PER BHEL EXISTANT RULES. THIS WILL BE WITHOUT PREJUDICE TO ANY OTHER RIGHT OF BHEL UNDER THE CONTRACT OR UNDER GENERAL LAW.
12. **ACTION AGAINST BIDDERS / VENDOR / SUPPLIER / CONTRACTOR IN CASE OF DEFAULT:**
IN ORDER TO PROTECT THE COMMERCIAL INTERESTS OF BHEL, BHEL SHALL TAKE ACTION AGAINST SUPPLIES / CONTRACTORS BY WAY OF SUSPENSION OF BUSINESS DEALINGS, WHO EITHER FAIL TO PERFORM OR ARE IN DEFAULT WITHOUT ANY REASONABLE CAUSE, CAUSE LOSS OF BUSINESS/ MONEY/ REPUTATION, INDULGE IN MALPRACTICES, CHEATING, BRIBERY, FRAUD OR ANY OTHER MISCONDUCT OR FORMATION OF CARTELS SO AS TO INFLUENCE THE BIDDING PROCESS OR INFLUENCE THE PRICE ETC.
SUSPENSION OF BUSINESS DEALINGS COULD BE IN THE FORM OF "HOLD" OR "BANNING" A SUPPLIER/ CONTRACTOR OR A BIDDER AND SHALL BE AS PER "GUIDELINES FOR SUSPENSION OF BUSINESS DEALINGS WITH SUPPLIERS/ CONTRACTORS" AVAILABLE AT BHEL'S WEBSITE <https://www.bhel.com/guidelines-suspension-business-dealings-supplierscontractors>

13. BIDDERS ARE ADVISED TO CHECK APPLICABLE GST ON THEIR OWN BEFORE QUOTING. BUYER WILL NOT TAKE ANY RESPONSIBILITY IN THIS REGARDS. GST REIMBURSEMENT WILL BE AS PER ACTUALS OR AS PER APPLICABLE RATES (WHICHEVER IS LOWER), SUBJECT TO THE MAXIMUM OF QUOTED GST %.

14. BIDDER SHALL SUBMIT THE FOLLOWING DOCUMENTS ALONG WITH THEIR BID FOR VENDOR CODE CREATION:
A. COPY OF PAN CARD B. COPY OF GSTIN C. COPY OF MSE CERIFICATE

15. DEDICATED /TOLL FREE TELEPHONE NO. FOR SERVICE SUPPORT: BIDDER/OEM MUST HAVE DEDICATED/TOLL FREE TELEPHONE NO. FOR SERVICE SUPPORT.

16. DATA SHEET OF THE PRODUCT(S) OFFERED IN THE BID, ARE TO BE UPLOADED ALONG WITH THE BID DOCUMENTS. BUYERS CAN MATCH AND VERIFY THE DATA SHEET WITH THE PRODUCT SPECIFICATIONS OFFERED. IN CASE OF ANY UNEXPLAINED MISMATCH OF TECHNICAL PARAMETERS, THE BID IS LIABLE FOR REJECTION.

17. SCOPE OF SUPPLY (BID PRICE TO INCLUDE ALL COST COMPONENTS): ONLY SUPPLY OF GOODS.

18. PRODUCTS SUPPLIED SHALL BE NONTOXIC AND HARMLESS TO HEALTH. IN THE CASE OF TOXIC MATERIALS, MATERIAL SAFETY DATA SHEET MAY BE FURNISHED ALONG WITH THE MATERIAL.

19. WHILE GENERATING INVOICE IN GEM PORTAL, THE SELLER MUST UPLOAD SCANNED COPY OF GST INVOICE AND THE SCREENSHOT OF GST PORTAL CONFIRMING PAYMENT OF GST.

20. PAYMENT TERMS SHALL BE AS PER FOLLOWINGS:

a) **For Non-MSME bidders:** 100% payment along with taxes, freight & insurance will be made after receipt and acceptance of material and within 90 days from the date of invoice subject to submission of non-discrepant documents within 15 days of supply as per terms and conditions of Purchase Order. (MSME means Micro, Small & Medium Enterprises) (THIS IS IN SUPERSESSION OF 10 DAYS' TIME AS PROVIDED IN CLAUSE 12 OF GEM GTC).

b) **FOR MSE BIDDER:** For MSEs (covered under MSME Act) which are registered and periodically renewed with BHEL, the payment will be made within 45 days or as prescribed in the relevant act. Benefits of MSE (such as EMD Waiver, Tender fee exemption, Price preference, Payment preference etc.) will be given only to those MSE Vendors who are manufacturers of offered items against the NIT. No MSE benefits shall be provided to Agents / Stockists /Dealers / Traders etc. for the items offered but not manufactured by themselves.”

c) **FOR MEDIUM ENTERPRISES:** 100% payment along with taxes, freight & insurance will be made after receipt and acceptance of material and within 60 days from the date of invoice subject to submission of non-discrepant documents within 15 days of supply as per terms and conditions of Purchase Order.

d) Please note that vendor to adhere to the payment terms as per above. No deviation in payment terms shall be accepted. Vendor to submit their offer accordingly.