



**BHARAT HEAVY ELECTRICALS LIMITED**  
**HEEP HARIDWAR INDIA-PIN 249403**  
**FAX NO: 0091 1334 226462**  
**PHONE NO: 0091 1334 285462**



### **REQUIREMENT OF CHAIN, HOIST**

The Heavy Electricals Equipment Plant (HEEP) located in Haridwar, India is one of the major manufacturing plants of Bharat Heavy Electricals Ltd. The core business of HEEP includes design and manufacture of large steam and gas turbines, turbo generators, Defense Items and so on.

Details of items details as below:

SLN	MAT CODE	ITEM DISCREPTION	QUANTITY (NOS.)	Lot No.	Lot Qty.	Dly. Schedule
1	W97016101029	CHAIN, HOIST SIZE: P/N 127623186	393	1	272	30.12.2024
				2	121	30.12.2025

1. EARLY DELIVERY ACCEPTABLE FOR LOT 1
2. EARLY DELIVERY IS ACCEPTABLE FROM OCTOBER 2025 (FOR 2ND LOT).
3. ALL VENDORS TO PROVIDE POINT WISE REPLY/CONFIRMATION ALONG WITH RELEVANT SUPPORTING DOCUMENTS TO EACH AND EVERY POINT OF **PRE-QUALIFICATION REQUIREMENT/PQR** FOR ALL ENQUIRY ITEMS. NONCOMPLIANCE OF THESE MAY LEAD TO REJECTION OF OFFER AS THESE ARE ESSENTIAL CONDITION FOR PARTICIPATING IN TENDER ENQUIRY.
4. KINDLY UPLOAD/ATTACH THE SPECIFICATION DETAILS/ CATALOGUE OF OFFERED ITEMS.
5. KINDLY **SUBMIT TECHNO-COMMERCIAL CHECKLIST** ALONG WITH YOUR OFFER.
6. VENDOR TO CONFIRM TO PROVIDE DIMENSIONAL AND MATERIAL TEST CERTIFICATES AS PER DRAWING AND SPECIFICATION ISO 606 ALONG WITH MATERIAL SUPPLY.
7. VENDOR TO CONFIRM TO PROVIDE LUBRICATION AND PRE-STRESSED REPORTS OF HOIST CHAIN.
8. VENDOR TO CONFIRM TO PROVIDE CERTIFICATE OF CONFORMANCE.
9. VENDOR TO CONFIRM TO PROVIDE NON REMOVEABLE IDENTIFICATION OF ITEMS AND SUBSEQUENT REPORT ACCORDINGLY.
10. VENDOR TO SUBMIT MAKE IN INDIA SELF CERTIFICATION AS PER FORMAT GIVEN ALONG WITH THE ENQUIRY.

**QUALIFYING CONDITIONS FOR CHAIN HOIST**

1.	who are capable to manufacture or supply Roller Chain Assembly as per attached drawing 37822312186	Vendor to confirm
2.	who can provide Certificate of Conformance (COC) for Roller Chain Assy. <i>(also known as Certificate of Conformity or Certificate of Compliance)</i>	Vendor to confirm

**(AGM-DPE)**

FIRST ANGLE PROJECTION

(ALL DIMENSIONS ARE IN mm)

FORM DG38(B)

37822312186  
DRAWING NO

✓ ALL OVER  
EXCEPT OTHERWISE

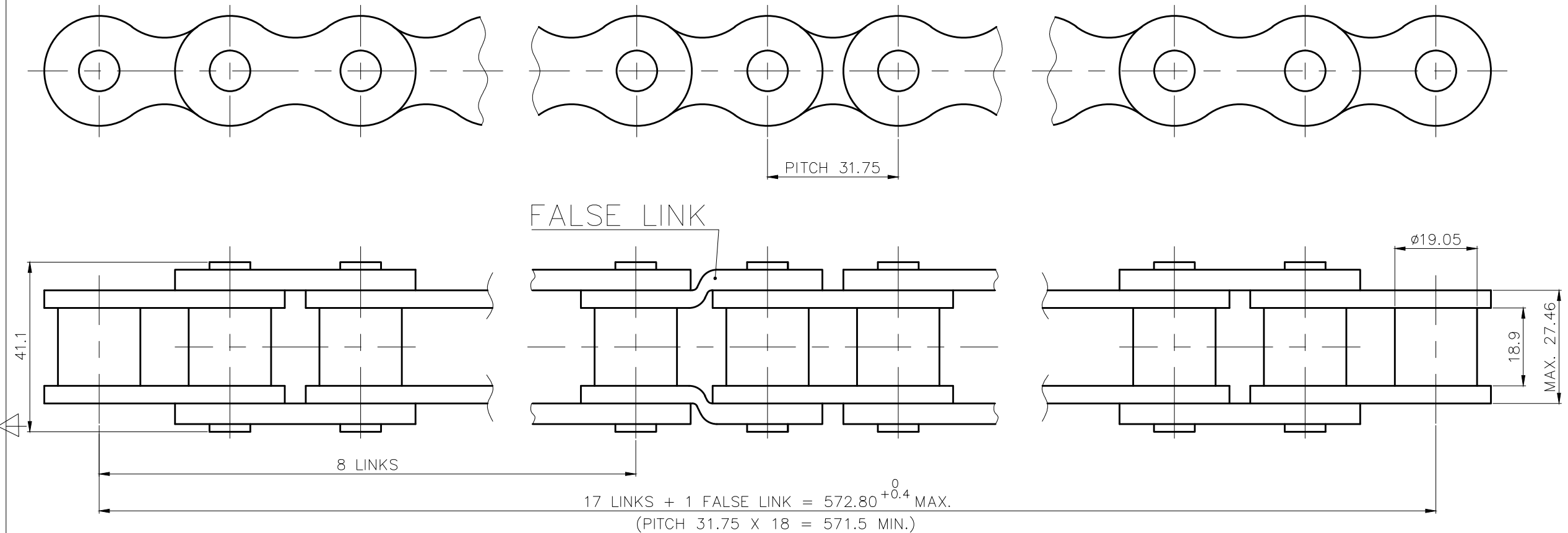

**TECH. REQ.:-**

1. REQUIRED SIMPLEX CHAIN NO. 20A AS PER ISO:606 (AMERICAN TYPE) WITH ONE OFFSET/CRANK/FALSE LINK AS PER DRG.
2. ULTIMATE TENSILE STRENGTH AS PER CHAIN NO. 20A OF ISO:606
3. GOOD QUALITY LUBRICATION TO BE PROVIDED ON CHAIN
4. CHAIN TO BE PRE-STRESSED TO ACCOMMODATE LENGTH CHANGES AT MANUFACTURING STAGE

GENERAL TOLERANCES LINEAR DIMENSIONS UP TO 18 ±0.15 > 18 TO 80 ±0.25 > 80 ±0.4 ANGLES ±30'	CASTING TOLERANCES LINEAR DIMENSIONS ±(0.5%+1MM) THICKNESS ±8% (MIN. ±0.5mm) ANGLES ±2'	FORGING TOLERANCES LINEAR DIMENSIONS UP TO 18 +0.5-0.3 > 18 TO 80 +1 -0.5 > 80 +2 -0.8 ANGLES ±1'	UNLESS OTHERWISE SPECIFIED ROUND EDGES 0.3 AND CHAMFER 0.3x45' SURFACE MARKED --- REQUIRE STOCK MATERIAL TO BE REMOVED AT ASSEMBLY
--	--	---	--

127623186-03  
REF. DRG. NO.  
SIGN & DATE  
INVENTORY NO.

GRADE OF UNTOL DIM :-		
M/CC - C/M/F AA0230208		
WELDING - A/B/C/D AA0621104		
GAS CUTTING - 'T3' AA0621101		
REV	DATE	ALTERED / CHECKED

GMS NO./GR SP NO		STATUS OF DRG	
27822318019/00			
AGREED DEPT.	NAME	SIGN	DATE

TYPE OF PRODUCT OR NAME OF CUSTOMER/PROJECT		<b>SRGM 76/62</b>			
BHARAT HEAVY ELECTRICALS LTD. HARDWAR	DRN	NAME	SIGN	DATE	NO.
	CHD	PRASHANT	sd/-	18.06.21	OF
	APD	SK SINGH	sd/-	18.06.21	VAR.
DEPT DPE	SCALE	WEIGHT (kg)	REF TO ASSY DRG.	ITEM NO	NO OF ITEMS
CODE 4260	NTS	--	27822318019	02	--
TITLE		CARD CODE	DRAWING NO.	REV.	
<b>CHAIN HOIST</b>		-	<b>37822312186</b>	-	
		SHEET NO. 01		NO.OF SHEETS 01	

## TECHNO-COMMERCIAL CHECKLIST

SL. NO.	TERMS & CONDITION	VENDOR CONFIRMATION /REMARKS / REPLY												
<b>TENDER DETAILS</b>														
1	BIDDER NAME													
2	GEM BID NO													
<b>QUALITY &amp; TECHNICAL REQUIREMENTS</b>														
3	ALL VENDORS TO PROVIDE POINT WISE REPLY/CONFIRMATION ALONG WITH RELEVANT SUPPORTING DOCUMENTS TO EACH AND EVERY POINT OF PRE-QUALIFICATION REQUIREMENT/PQR FOR ALL ENQUIRY ITEMS. NONCOMPLIANCE OF THESE MAY LEAD TO REJECTION OF OFFER AS THESE ARE ESSENTIAL CONDITION FOR PARTICIPATING IN TENDER ENQUIRY.													
4	KINDLY UPLOAD/ATTACH THE SPECIFICATION DETAILS/ CATALOGUE OF OFFERED ITEMS.													
5	VENDOR TO CONFIRM TO PROVIDE DIMENSIONAL AND MATERIAL TEST CERTIFICATES AS PER DRAWING AND SPECIFICATION ISO 606 ALONG WITH MATERIAL SUPPLY.													
6	VENDOR TO CONFIRM TO PROVIDE LUBRICATION AND PRE-STRESSED REPORTS OF HOIST CHAIN.													
7	VENDOR TO CONFIRM TO PROVIDE CERTIFICATE OF CONFORMANCE.													
8	VENDOR TO CONFIRM TO PROVIDE NON REMOVEABLE IDENTIFICATION OF ITEMS AND SUBSEQUENT REPORT ACCORDINGLY.													
<b>COMMERICAL REMARKS</b>														
9	<table border="1" style="width: 100%;"><thead><tr><th style="text-align: center;">QUANTITY (NOS.)</th><th style="text-align: center;">Lot No.</th><th style="text-align: center;">Lot Qty.</th><th style="text-align: center;">Dly. Schedule</th></tr></thead><tbody><tr><td style="text-align: center;">393</td><td style="text-align: center;">1</td><td style="text-align: center;">272</td><td style="text-align: center;">30.12.2024</td></tr><tr><td></td><td style="text-align: center;">2</td><td style="text-align: center;">121</td><td style="text-align: center;">30.12.2025</td></tr></tbody></table>	QUANTITY (NOS.)	Lot No.	Lot Qty.	Dly. Schedule	393	1	272	30.12.2024		2	121	30.12.2025	
QUANTITY (NOS.)	Lot No.	Lot Qty.	Dly. Schedule											
393	1	272	30.12.2024											
	2	121	30.12.2025											
10	ITEM IS TO BE SUPPLIED AS PER TECHNICAL SPECIFICATION/DRAWING													
11	KINDLY ARRANGE TO SUBMIT MAKE IN INDIA SELF CERTIFICATION													
12	KINDLY UPLOAD/ATTACH THE SPECIFICATION DETAILS/ CATALOGUE OF OFFERED ITEMS.													

13	<p><b>RISK PURCHASE:</b> IN CASE OF ABNORMAL DELAYS (BEYOND THE MAXIMUM LATE DELIVERY PERIOD AS PER LD CLAUSE) IN SUPPLIES / DEFECTIVE SUPPLIES OR NONFULFILLMENT OF ANY OTHER TERMS AND CONDITIONS GIVEN IN PURCHASE ORDER, BHEL MAY CANCEL THE PURCHASE ORDER IN FULL OR PART THEREOF, AND MAY ALSO MAKE THE PURCHASE OF SUCH MATERIAL FROM ELSEWHERE / ALTERNATIVE SOURCE AT THE RISK AND COST OF THE SUPPLIER. BHEL WILL TAKE ALL REASONABLE STEPS TO GET THE MATERIAL FROM ALTERNATE SOURCE AT OPTIMUM COST. IF BIDDER DOES NOT AGREE TO THE ABOVE RISK PURCHASE CLAUSE, BHEL RESERVES THE RIGHT TO REJECT THE OFFER. IN CASE FOR COMPELLING REASONS BHEL ACCEPTS THE OFFER WITHOUT ACCEPTANCE OF THIS CLAUSE BY THE BIDDER AND IN THE EVENTUALITY OF RISK PURCHASE, APPROPRIATE ACTION WILL BE TAKEN AS PER BHEL EXTANT RULES. THIS WILL BE WITHOUT PREJUDICE TO ANY OTHER RIGHT OF BHEL UNDER THE CONTRACT OR UNDER GENERAL LAW.</p> <p>IN CASE OF BREACH OF CONTRACT, WHEREVER THE VALUE OF SECURITY INSTRUMENTS LIKE PERFORMANCE BANK GUARANTEE AVAILABLE WITH BHEL AGAINST THE SAID CONTRACT IS ATLEAST 10% OF THE CONTRACT VALUE, THE SAME BE ENCASHED. IN CASE THE VALUE OF THE SECURITY INSTRUMENTS AVAILABLE IS LESS THAN 10% OF THE CONTRACT VALUE, THE BALANCE AMOUNT BE RECOVERED FROM OTHER FINANCIAL REMEDIES (I.E. AVAILABLE BILLS OF THE CONTRACTOR, RETENTION AMOUNT, ETC. WITH BHEL) OR LEGAL REMEDIES BE PURSUED.</p>	
14	<p><b>ACTION AGAINST BIDDERS / VENDOR / SUPPLIER / CONTRACTOR IN CASE OF DEFAULT:</b></p> <p>IN ORDER TO PROTECT THE COMMERCIAL INTERESTS OF BHEL, BHEL SHALL TAKE ACTION AGAINST SUPPLIES / CONTRACTORS BY WAY OF SUSPENSION OF BUSINESS DEALINGS, WHO EITHER FAIL TO PERFORM OR ARE IN DEFAULT WITHOUT ANY REASONABLE CAUSE, CAUSE LOSS OF BUSINESS/ MONEY/ REPUTATION, INDULGE IN MALPRACTICES, CHEATING, BRIBERY, FRAUD OR ANY OTHER MISCONDUCT OR FORMATION OF CARTELS SO AS TO INFLUENCE THE BIDDING PROCESS OR INFLUENCE THE PRICE ETC.</p> <p>SUSPENSION OF BUSINESS DEALINGS COULD BE IN THE FORM OF “HOLD” OR “BANNING” A SUPPLIER/ CONTRACTOR OR A BIDDER AND SHALL BE AS PER “GUIDELINES FOR SUSPENSION OF BUSINESS DEALINGS WITH SUPPLIERS/ CONTRACTORS” AVAILABLE AT BHEL’S WEBSITE “<a href="https://www.bhel.com/guidelines-suspension-business-dealings-supplierscontractors">https://www.bhel.com/guidelines-suspension-business-dealings-supplierscontractors</a>”</p>	
15	REST GENERAL TERMS AND CONDITIONS SHALL BE AS PER GEM	

**MAKE IN INDIA SELF CERTIFICATION**

As per Government Public procurement order no. P-45021/2/2017-BE-II dt.15.06.2017 & P45021/2/2017-PP(BE-II) dated 28.05.2018,29.5.2019, 04.6.2020 and amendment dated 16.09.2020, it is hereby certifying that we

.....  
..... (supplier name) are .....(Class-I/Class-II)  
local supplier and will meet the requirement of minimum local content of .....  
(50%/20%) as defined in public procurement order dated 04.6.2020 for material against Enquiry no.  
..... Details of  
location at which local value addition will be made is as follows: -  
.....  
.....  
.....

We also understand, false declarations will be in breach of the code of integrity under Rule 175(1)(i)(h) of the General Financial Rules for which a bidder or its successors can be debarred for up to two years as per Rule 151 (iii) of the general financial rules along with such other actions as may be permissible under law.

**Note:**

As per office order P-45021/102/2019-BE-II-Part (1) (E-50310) Dated 04/03/2021, Bidders can't claim itself as "Class-I local supplier/Class-II local suppliers" by claiming the service such as transportation, insurance, installation, commissioning, training & after sales service support like AMC/CMC etc. as local value addition. Bidder offering imported product will fall under the category of Non-Local supplier.

1. EARLY DELIVERY ACCEPTABLE FOR LOT 1
2. EARLY DELIVERY IS ACCEPTABLE FROM OCTOBER 2025 (FOR 2ND LOT).
3. ALL VENDORS TO PROVIDE POINT WISE REPLY/CONFIRMATION ALONG WITH RELEVANT SUPPORTING DOCUMENTS TO EACH AND EVERY POINT OF **PRE-QUALIFICATION REQUIREMENT/PQR** FOR ALL ENQUIRY ITEMS. NONCOMPLIANCE OF THESE MAY LEAD TO REJECTION OF OFFER AS THESE ARE ESSENTIAL CONDITION FOR PARTICIPATING IN TENDER ENQUIRY.
4. KINDLY UPLOAD/ATTACH THE SPECIFICATION DETAILS/ CATALOGUE OF OFFERED ITEMS.
5. KINDLY **SUBMIT TECHNO-COMMERCIAL CHECKLIST** ALONG WITH YOUR OFFER.
6. VENDOR TO CONFIRM TO PROVIDE DIMENSIONAL AND MATERIAL TEST CERTIFICATES AS PER DRAWING AND SPECIFICATION ISO 606 ALONG WITH MATERIAL SUPPLY.
7. VENDOR TO CONFIRM TO PROVIDE LUBRICATION AND PRE-STRESSED REPORTS OF HOIST CHAIN.
8. VENDOR TO CONFIRM TO PROVIDE CERTIFICATE OF CONFORMANCE.
9. VENDOR TO CONFIRM TO PROVIDE NON REMOVEABLE IDENTIFICATION OF ITEMS AND SUBSEQUENT REPORT ACCORDINGLY.
10. VENDOR TO SUBMIT MAKE IN INDIA SELF CERTIFICATION AS PER FORMAT GIVEN ALONG WITH THE ENQUIRY.
11. WARRANTY/GUARANTEE APPLICABLE AS PER THE CLAUSE 10 OF GENERAL TERMS AND CONDITIONS.
12. MSE/MII: THE SUPPLIER NEEDS TO SUBMIT/UPDATE MSE/MII CREDENTIALS ON GEM PORTAL DURING PROFILE UPDATION/ OFFER SUBMISSION STAGE. THE MSE DATA SUBMITTED IS CROSS VERIFIED BY GEM WITH GOVT. OF INDIA UDYAM/NSIC DATABASE THROUGH API INTEGRATION ON REAL TIME BASIS AND FOR MII, A SELF DECLARATION IS BEING GIVEN AND AUTHENTICATED BY AADHAR OTP. IF THE SELLER FAILS TO CLAIM MSE/MII PROVISION ON GEM PORTAL AT PROFILE UPDATION/BID SUBMISSION STAGE, THE SAID SELLER WILL BECOME INELIGIBLE FOR GETTING THE MSE/MII BENEFITS FOR THAT BID AUTOMATICALLY. THE VENDOR CAN ALWAYS CONTACT THE GEM HELPDESK, IN CASE OF ANY ISSUES.
13. THE PRICE QUOTE BY BIDDER SHOULD BE INCLUSIVE OF GST & SHOULD BE ON BHEL HEEP HARIDWAR STORES BASIS.
14. BIDDER'S OFFER IS LIABLE TO BE REJECTED IF THEY DON'T UPLOAD ANY OF THE CERTIFICATES / DOCUMENTS SOUGHT IN THE BID DOCUMENT, ATC AND CORRIGENDUM IF ANY.
15. **RISK PURCHASE:**

IN CASE OF ABNORMAL DELAYS (BEYOND THE MAXIMUM LATE DELIVERY PERIOD AS PER LD CLAUSE) IN SUPPLIES / DEFECTIVE SUPPLIES OR NONFULFILLMENT OF ANY OTHER TERMS AND CONDITIONS GIVEN IN PURCHASE ORDER, BHEL MAY CANCEL THE PURCHASE ORDER IN FULL OR PART THEREOF, AND MAY ALSO MAKE THE PURCHASE OF SUCH MATERIAL FROM ELSEWHERE / ALTERNATIVE SOURCE AT THE RISK AND COST OF THE SUPPLIER. BHEL WILL TAKE ALL REASONABLE STEPS TO GET THE MATERIAL FROM ALTERNATE SOURCE AT OPTIMUM COST. IF BIDDER DOES NOT AGREE TO THE ABOVE RISK PURCHASE CLAUSE, BHEL RESERVES THE RIGHT TO REJECT THE OFFER. IN CASE FOR COMPELLING REASONS BHEL ACCEPTS THE OFFER WITHOUT ACCEPTANCE OF THIS CLAUSE BY THE BIDDER AND IN THE EVENTUALITY OF RISK PURCHASE, APPROPRIATE ACTION WILL BE TAKEN AS PER BHEL EXTANT RULES. THIS WILL BE WITHOUT PREJUDICE TO ANY OTHER RIGHT OF BHEL UNDER THE CONTRACT OR UNDER GENERAL LAW.

IN CASE OF BREACH OF CONTRACT, WHEREVER THE VALUE OF SECURITY INSTRUMENTS LIKE PERFORMANCE BANK GUARANTEE AVAILABLE WITH BHEL AGAINST THE SAID CONTRACT IS ATLEAST

10% OF THE CONTRACT VALUE, THE SAME BE ENCASHED. IN CASE THE VALUE OF THE SECURITY INSTRUMENTS AVAILABLE IS LESS THAN 10% OF THE CONTRACT VALUE, THE BALANCE AMOUNT BE RECOVERED FROM OTHER FINANCIAL REMEDIES (I.E. AVAILABLE BILLS OF THE CONTRACTOR, RETENTION AMOUNT, ETC. WITH BHEL) OR LEGAL REMEDIES BE PURSUED.

16. **ACTION AGAINST BIDDERS / VENDOR / SUPPLIER / CONTRACTOR IN CASE OF DEFAULT:**  
IN ORDER TO PROTECT THE COMMERCIAL INTERESTS OF BHEL, BHEL SHALL TAKE ACTION AGAINST SUPPLIES / CONTRACTORS BY WAY OF SUSPENSION OF BUSINESS DEALINGS, WHO EITHER FAIL TO PERFORM OR ARE IN DEFAULT WITHOUT ANY REASONABLE CAUSE, CAUSE LOSS OF BUSINESS/ MONEY/ REPUTATION, INDULGE IN MALPRACTICES, CHEATING, BRIBERY, FRAUD OR ANY OTHER MISCONDUCT OR FORMATION OF CARTELS SO AS TO INFLUENCE THE BIDDING PROCESS OR INFLUENCE THE PRICE ETC.  
SUSPENSION OF BUSINESS DEALINGS COULD BE IN THE FORM OF "HOLD" OR "BANNING" A SUPPLIER/ CONTRACTOR OR A BIDDER AND SHALL BE AS PER "GUIDELINES FOR SUSPENSION OF BUSINESS DEALINGS WITH SUPPLIERS/ CONTRACTORS" AVAILABLE AT BHEL'S WEBSITE <https://www.bhel.com/guidelines-suspension-business-dealings-supplierscontractors>
17. BIDDERS ARE ADVISED TO CHECK APPLICABLE GST ON THEIR OWN BEFORE QUOTING. BUYER WILL NOT TAKE ANY RESPONSIBILITY IN THIS REGARDS. GST REIMBURSEMENT WILL BE AS PER ACTUALS OR AS PER APPLICABLE RATES (WHICHEVER IS LOWER), SUBJECT TO THE MAXIMUM OF QUOTED GST %.
18. BIDDER SHALL SUBMIT THE FOLLOWING DOCUMENTS ALONG WITH THEIR BID FOR VENDOR CODE CREATION:
- A. COPY OF PAN CARD B. COPY OF GSTIN C. COPY OF MSE CERIFICATE**
19. DEDICATED /TOLL FREE TELEPHONE NO. FOR SERVICE SUPPORT: BIDDER/OEM MUST HAVE DEDICATED/TOLL FREE TELEPHONE NO. FOR SERVICE SUPPORT.
20. DATA SHEET OF THE PRODUCT(S) OFFERED IN THE BID, ARE TO BE UPLOADED ALONG WITH THE BID DOCUMENTS. BUYERS CAN MATCH AND VERIFY THE DATA SHEET WITH THE PRODUCT SPECIFICATIONS OFFERED. IN CASE OF ANY UNEXPLAINED MISMATCH OF TECHNICAL PARAMETERS, THE BID IS LIABLE FOR REJECTION.
21. SCOPE OF SUPPLY (BID PRICE TO INCLUDE ALL COST COMPONENTS): ONLY SUPPLY OF GOODS.
22. PRODUCTS SUPPLIED SHALL BE NONTOXIC AND HARMLESS TO HEALTH. IN THE CASE OF TOXIC MATERIALS, MATERIAL SAFETY DATA SHEET MAY BE FURNISHED ALONG WITH THE MATERIAL.
23. WHILE GENERATING INVOICE IN GEM PORTAL, THE SELLER MUST UPLOAD SCANNED COPY OF GST INVOICE AND THE SCREENSHOT OF GST PORTAL CONFIRMING PAYMENT OF GST.
24. **PAYMENT TERMS SHALL BE AS PER FOLLOWINGS:**
- a) **FOR NON-MSES BIDDER:** 100% payment along with taxes, freight & insurance will be made after receipt and acceptance of material and within 90 days from the date of invoice subject to submission of non-discrepant documents within 15 days of supply as per terms and conditions of Purchase Order (THIS IS IN SUPERSESION OF 10 DAYS' TIME AS PROVIDED IN CLAUSE 12 OF GEM GTC).
- b) **FOR MSES BIDDER:** For MSEs (covered under MSME Act) which are registered and periodically renewed with BHEL, the payment will be made within 45 days or as prescribed in the relevant act. Benefits of MSE (such as EMD Waiver, Tender fee exemption, Price preference, Payment preference etc.) will be given only to those MSE Vendors who are manufacturers of offered items against the NIT. No MSE benefits shall be provided to Agents / Stockists /Dealers / Traders etc. for the items offered but not manufactured by themselves."

- c) **FOR MEDIUM ENTERPRISES:** 100% payment along with taxes, freight & insurance will be made after receipt and acceptance of material and within 60 days from the date of invoice subject to submission of non-discrepant documents within 15 days of supply as per terms and conditions of Purchase Order.
- d) Please note that vendor to adhere to the payment terms as per above. No deviation in payment terms shall be accepted. Vendor to submit their offer accordingly.