



REQUIREMENT OF CIRCLIP FOR SNAP RING, CIRCLIP ETC.

The Heavy Electricals Equipment Plant (HEEP) located in Haridwar, India is one of the major manufacturing plants of Bharat Heavy Electricals Ltd. The core business of HEEP includes design and manufacture of large steam and gas turbines, turbo generators, Defense Items and so on.

Details of items details as below:

SLN	MAT CODE	ITEM DISCREPTION	QUANTITY (NOS.)	Delivery (Days)
1	W97034203032	SNAP RING FOR SHAFT OF DIA-20 AS PER DIN 7993A, MATERIAL: SPRING STEEL, FINISH: PHOSPHATISED/BLACK N.STD: DIN: 7993 A SIZE: P/N 220011775	300	45
2	W97034202117	CIRCLIP FOR BORES, 72 DIA AS PER IS-3075 (PART-II) MATERIAL: C75 AS PER IS:2507 FINISH: PHOSPHATISED N.STD:IS:3075 SIZE: P/N 220011740	300	45
3	W97034201153	CIRCLIP FOR SHAFT, 63 DIA AS PER IS-3075 (PART-I) MATERIAL: C75 AS PER IS:2507 FINISH: PHOSPHATISED N.STD:IS:3075 SIZE: P/N 220011640	300	45

1. ALL VENDORS TO PROVIDE POINT WISE REPLY/CONFIRMATION ALONG WITH RELEVANT SUPPORTING DOCUMENTS TO EACH AND EVERY POINT OF PRE-QUALIFICATION REQUIREMENT/PQR FOR ALL ENQUIRY ITEMS. NONCOMPLIANCE OF THESE MAY LEAD TO REJECTION OF OFFER AS THESE ARE ESSENTIAL CONDITION FOR PARTICIPATING IN TENDER ENQUIRY
2. KINDLY UPLOAD/ATTACH THE SPECIFICATION DETAILS/ CATALOGUE OF OFFERED ITEMS (IF APPLICABLE).
3. KINDLY ARRANGE TO **SUBMIT TECHNO-COMMERCIAL CHECKLIST** ALONG WITH YOUR OFFER.
4. KINDLY SUMIT THE **TECHNICAL PARAMETERS CHECK LIST** ALONG WITH YOUR OFFER.
5. VENDOR TO CONFIRM TO PROVIDE MATERIAL AND DIMENSIONAL TEST CERTIFICATES OF ITEMS ALONG WITH MATERIAL DISPATCH.
6. VENDOR TO CONFIRM TO PROVIDE DOCUMENTS KEEP PROPER CORRELATION WITH PO ITEMS AND THEIR QUANTITY.
7. VENDOR TO CONFIRM TO PROVIDE CERTIFICATE OF CONFORMANCE ALONG WITH MATERIAL DISPATCH.
8. VENDOR TO CONFIRM TO PROVIDE NON REMOVABLE IDENTIFICATION OF ITEMS AND PROVIDE REPORT ACCORDINGLY.
9. EARLY DELIVERY IS ACCEPTABLE.

QUALIFYING CONDITIONS for SNAP RING AND CIRCLIP

SN.	CLAUSE	VENDOR RESPONSE	Vendor Response (Yes / No / Enclosed)
1.	Who can either manufacture or supply SNAP RING AND CIRCLIP as per BHEL requirement / Enquiry with national /international standard.	<i>Vendor to Confirm</i>	
2.	Who can provide Material test certificate (MTC) with chemical & mechanical properties from NABL certified / Govt. approved Labs/ OEM Certified lab	<i>Vendor to Confirm</i>	
3.	Who can provide Certificate of Conformance / Compliance (COC)	<i>Vendor to Confirm</i>	

TECHNICAL PARAMETERS CHECK LIST
DATA VALUES TO BE FILLED AND CONFIRMED BY VENDOR

ITEM CODE W97034201153
 ITEM NAME CIRCLIP FOR SHAFT, DIA 63
 ITEM PART NO P/N 220011640

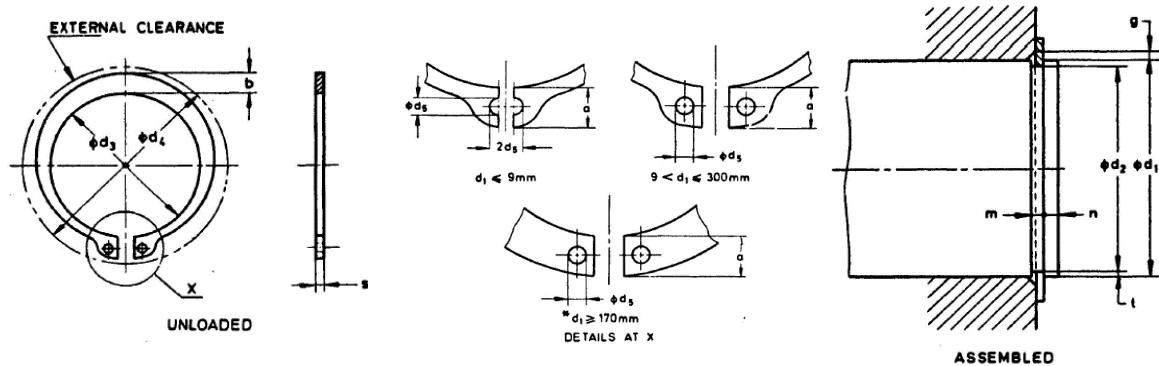

NOTE: Vendor to input parameters based on the specification of the item quoted.

SN.	PARAMETERS	VALUES	TOLERANCE	UNIT	RESPONSE TYPE	VENDOR RESPONSE
1	QUOTED AS PER	IS-3075 Part-1	-	-	Specify Spec.	➔
2	Shaft dia d1	63	-	MM	Input Value	➔
3	d3	58.8	+ 0.46 - 1.1	MM	Input Value	➔
4	d5	2.5	-	MM	Input Value	➔
5	b	6.2	-	MM	Input Value	➔
6	a	7.6 max	-	MM	Input Value	➔
7	s	2	+ 0.06 + 0.06	MM	Input Value	➔
8	AXIAL LOAD BEARING CAPACITY	70.2		KN	Input Value	➔
9	MATERIAL	75C6 AS PER IS:2507 OR UNI 3545	C75	-	To confirm	➔
10	FINISH	PHOSPHATISED		-	To confirm	➔
11	CERTIFICATION	Certificate of Conformance / Compliance (COC)		YES	Cconfirm to supply	➔

12. VENDOR REMARKS

TECHNICAL PARAMETERS CHECK LIST
DATA VALUES TO BE FILLED AND CONFIRMED BY VENDOR

ITEM CODE W97034202117
 ITEM NAME CIRCLIP FOR BORES, DIA 72
 ITEM PART NO P/N 220011740

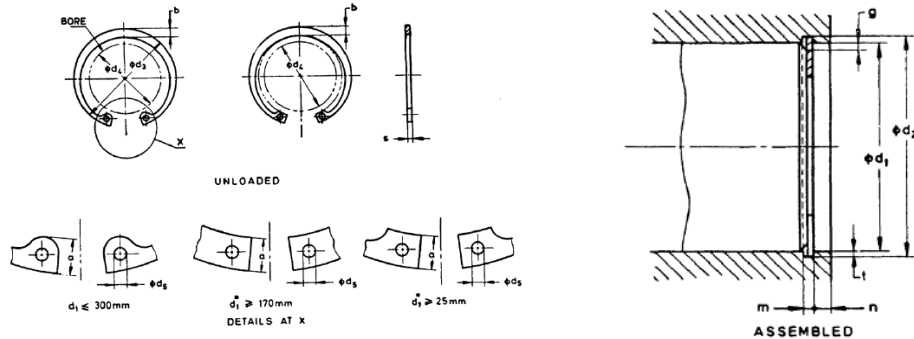

NOTE: Vendor to input parameters based on the specification of the item quoted.

SN.	PARAMETERS	VALUES	TOLERANCE	UNIT	RESPONSE TYPE	VENDOR RESPONSE
1	QUOTED AS PER	IS-3075 Part-2	-	-	Specify Spec.	➔
2	bore dia d1	72	-	MM	To confirm	➔
3	d3	76.5	+ 1.1 - 0.46	MM	To confirm	➔
4	d5	3	-	MM	Input Value	➔
5	b	6.4	-	MM	Input Value	➔
6	a	7.8 max	-	MM	Input Value	➔
7	s	2.5	+ 0.06 + 0.06	MM	Input Value	➔
8	AXIAL LOAD BEARING CAPACITY	86.5		KN	Input Value	➔
9	MATERIAL	75C6 AS PER IS:2507 OR C75 UNI 3545		-	To confirm	➔
10	FINISH	PHOSPHATISED		-	To confirm	➔
11	CERTIFICATION	Certificate of Conformance / Compliance (COC)		YES	Cconfirm to supply	➔

12. VENDOR REMARKS

TECHNICAL PARAMETERS CHECK LIST
DATA VALUES TO BE FILLED AND CONFIRMED BY VENDOR

ITEM CODE W97034203032
 ITEM NAME SNAP RING FOR SHAFT, DIA-20
 ITEM PART NO P/N 220011775
 Dimensions in mm.

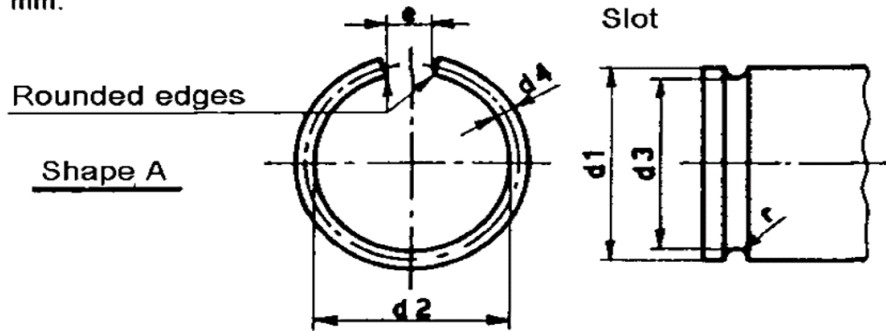

NOTE: Vendor to input parameters based on the specification of the item quoted.

SN.	PARAMETERS	VALUES	TOLERANCE	UNIT	RESPONSE TYPE	VENDOR RESPONSE
1	QUOTED AS PER	DIN 7993A UNI 7433	-	-	Specify Spec.	→
2	d1	20	-	MM	To confirm	→
3	d2	17.7	+ 0.0 - 0.5	MM	Input Value	→
4	d3	18	+ 0.1 - 0.1	MM	Input Value	→
5	d4	2	+ 0.03 + 0.03	MM	Input Value	→
6	e	3	-	MM	Input Value	→
7	ANGULAR SPEED, MAX.	17500		RPM	Input Value	→
8	MATERIAL	SPRING STEEL		-	To confirm	→
9	FINISH	PHOSPHATISED		-	To confirm	→
10	CERTIFICATION	Certificate of Conformance / Compliance (COC)		YES	Cconfirm to supply	→

11. VENDOR REMARKS

TECHNO-COMMERCIAL CHECKLIST

SL. NO.	TERMS & CONDITION	VENDOR CONFIRMATION /REMARKS / REPLY
TENDER DETAILS		
1	BIDDER NAME	
2	GEM BID NO	
QUALITY & TECHNICAL REQUIREMENT		
3	VENDOR TO CONFIRM TO PROVIDE MATERIAL AND DIMENSIONAL TEST CERTIFICATES OF ITEMS ALONG WITH MATERIAL DISPATCH.	
4	VENDOR TO CONFIRM TO PROVIDE DOCUMENTS KEEP PROPER CORRELATION WITH PO ITEMS AND THEIR QUANTITY.	
5	VENDOR TO CONFIRM TO PROVIDE CERTIFICATE OF CONFORMANCE ALONG WITH MATERIAL DISPATCH.	
6	VENDOR TO CONFIRM TO PROVIDE NON REMOVABLE IDENTIFICATION OF ITEMS AND PROVIDE REPORT ACCORDINGLY.	
COMMERICAL REMARKS		
7	ITEM IS TO BE SUPPLIED AS PER TECHNICAL SPECIFICATION/DRAWING	
8	KINDLY ARRANGE TO SUBMIT MAKE IN INDIA SELF CERTIFICATION	
9	KINDLY UPLOAD/ATTACH THE SPECIFICATION DETAILS/ CATALOGUE OF OFFERED ITEMS.	
10	<p>RISK PURCHASE: IN CASE OF ABNORMAL DELAYS (BEYOND THE MAXIMUM LATE DELIVERY PERIOD AS PER LD CLAUSE) IN SUPPLIES / DEFECTIVE SUPPLIES OR NONFULFILLMENT OF ANY OTHER TERMS AND CONDITIONS GIVEN IN PURCHASE ORDER, BHEL MAY CANCEL THE PURCHASE ORDER IN FULL OR PART THEREOF, AND MAY ALSO MAKE THE PURCHASE OF SUCH MATERIAL FROM ELSEWHERE / ALTERNATIVE SOURCE AT THE RISK AND COST OF THE SUPPLIER. BHEL WILL TAKE ALL REASONABLE STEPS TO GET THE MATERIAL FROM ALTERNATE SOURCE AT OPTIMUM COST. IF BIDDER DOES NOT AGREE TO THE ABOVE RISK PURCHASE CLAUSE, BHEL RESERVES THE RIGHT TO REJECT THE OFFER. IN CASE FOR COMPELLING REASONS BHEL ACCEPTS THE OFFER WITHOUT ACCEPTANCE OF THIS CLAUSE BY THE BIDDER AND IN THE EVENTUALITY OF RISK PURCHASE, APPROPRIATE ACTION WILL BE TAKEN AS PER BHEL EXTANT RULES. THIS WILL BE WITHOUT PREJUDICE TO ANY OTHER RIGHT OF BHEL UNDER THE CONTRACT OR UNDER GENERAL LAW.</p> <p>IN CASE OF BREACH OF CONTRACT, WHEREVER THE VALUE OF SECURITY INSTRUMENTS LIKE PERFORMANCE BANK GUARANTEE AVAILABLE WITH BHEL AGAINST THE SAID CONTRACT IS ATLEAST 10% OF THE CONTRACT VALUE, THE SAME BE ENCASHED. IN CASE THE VALUE OF THE SECURITY INSTRUMENTS AVAILABLE IS LESS THAN 10% OF THE CONTRACT VALUE, THE BALANCE AMOUNT BE RECOVERED FROM OTHER FINANCIAL REMEDIES (I.E. AVAILABLE BILLS OF THE CONTRACTOR, RETENTION AMOUNT, ETC. WITH BHEL) OR LEGAL REMEDIES BE PURSUED.</p>	
11	<p>ACTION AGAINST BIDDERS / VENDOR / SUPPLIER / CONTRACTOR IN CASE OF DEFAULT: IN ORDER TO PROTECT THE COMMERCIAL INTERESTS OF BHEL, BHEL SHALL TAKE ACTION AGAINST SUPPLIES / CONTRACTORS BY WAY OF SUSPENSION OF BUSINESS DEALINGS, WHO EITHER FAIL TO PERFORM OR ARE IN DEFAULT WITHOUT ANY REASONABLE CAUSE, CAUSE LOSS OF BUSINESS/ MONEY/ REPUTATION, INDULGE IN MALPRACTICES, CHEATING, BRIBERY, FRAUD OR ANY OTHER MISCONDUCT OR FORMATION OF CARTELS SO AS TO INFLUENCE THE BIDDING PROCESS OR INFLUENCE THE PRICE ETC.</p> <p>SUSPENSION OF BUSINESS DEALINGS COULD BE IN THE FORM OF "HOLD" OR "BANNING" A SUPPLIER/ CONTRACTOR OR A BIDDER AND SHALL BE AS PER "GUIDELINES FOR SUSPENSION OF BUSINESS DEALINGS WITH SUPPLIERS/ CONTRACTORS" AVAILABLE AT BHEL'S WEBSITE "https://www.bhel.com/guidelines-suspension-business-dealings-supplierscontractors"</p>	
12	REST GENERAL TERMS AND CONDITIONS SHALL BE AS PER GEM	

1. ALL VENDORS TO PROVIDE POINT WISE REPLY/CONFIRMATION ALONG WITH RELEVANT SUPPORTING DOCUMENTS TO EACH AND EVERY POINT OF PRE-QUALIFICATION REQUIREMENT/PQR FOR ALL ENQUIRY ITEMS. NONCOMPLIANCE OF THESE MAY LEAD TO REJECTION OF OFFER AS THESE ARE ESSENTIAL CONDITION FOR PARTICIPATING IN TENDER ENQUIRY.
 2. KINDLY UPLOAD/ATTACH THE SPECIFICATION DETAILS/CATALOGUE OF OFFERED ITEMS (IF APPLICABLE).
 3. KINDLY ARRANGE TO SUBMIT TECHNO-COMMERCIAL CHECKLIST ALONG WITH YOUR OFFER.
 4. KINDLY SUMIT THE TECHNICAL PARAMETERS CHECK LIST ALONG WITH YOUR OFFER.
 5. VENDOR TO CONFIRM TO PROVIDE MATERIAL AND DIMENSIONAL TEST CERTIFICATES OF ITEMS ALONG WITH MATERIAL DISPATCH.
 6. VENDOR TO CONFIRM TO PROVIDE DOCUMENTS KEEP PROPER CORRELATION WITH PO ITEMS AND THEIR QUANTITY.
 7. VENDOR TO CONFIRM TO PROVIDE CERTIFICATE OF CONFORMANCE ALONG WITH MATERIAL DISPATCH.
 8. VENDOR TO CONFIRM TO PROVIDE NON REMOVABALE IDENTIFICATION OF ITEMS AND PROVIDE REPORT ACCORDINGLY.
 9. EARLY DELIVERY IS ACCEPTABLE.
1. MSE/MII: THE SUPPLIER NEEDS TO SUBMIT/UPDATE MSE/MII CREDENTIALS ON GEM PORTAL DURING PROFILE UPDATION/ OFFER SUBMISSION STAGE. THE MSE DATA SUBMITTED IS CROSS VERIFIED BY GEM WITH GOVT. OF INDIA UDYAM/NSIC DATABASE THROUGH API INTEGRATION ON REAL TIME BASIS AND FOR MII, A SELF DECLARATION IS BEING GIVEN AND AUTHENTICATED BY AADHAR OTP. IF THE SELLER FAILS TO CLAIM MSE/MII PROVISION ON GEM PORTAL AT PROFILE UPDATION/BID SUBMISSION STAGE, THE SAID SELLER WILL BECOME INELIGIBLE FOR GETTING THE MSE/MII BENEFITS FOR THAT BID AUTOMATICLLY. THE VENDOR CAN ALWAYS CONTACT THE GEM HELPDESK, IN CASE OF ANY ISSUES.
 2. THE PRICE QUOTE BY BIDDER SHOULD BE INCLUSIVE OF GST & SHOULD BE ON BHEL HEEP HARIDWAR STORES BASIS.
 3. BIDDER'S OFFER IS LIABLE TO BE REJECTED IF THEY DON'T UPLOAD ANY OF THE CERTIFICATES / DOCUMENTS SOUGHT IN THE BID DOCUMENT, ATC AND CORRIGENDUM IF ANY.
 4. **RISK PURCHASE:**
IN CASE OF ABNORMAL DELAYS (BEYOND THE MAXIMUM LATE DELIVERY PERIOD AS PER LD CLAUSE) IN SUPPLIES / DEFECTIVE SUPPLIES OR NONFULFILLMENT OF ANY OTHER TERMS AND CONDITIONS GIVEN IN PURCHASE ORDER, BHEL MAY CANCEL THE PURCHASE ORDER IN FULL OR PART THEREOF, AND MAY ALSO MAKE THE PURCHASE OF SUCH MATERIAL FROM ELSEWHERE / ALTERNATIVE SOURCE AT THE RISK AND COST OF THE SUPPLIER. BHEL WILL TAKE ALL REASONABLE STEPS TO GET THE MATERIAL FROM ALTERNATE SOURCE AT OPTIMUM COST. IF BIDDER DOES NOT AGREE TO THE ABOVE RISK PURCHASE CLAUSE, BHEL RESERVES THE RIGHT TO REJECT THE OFFER. IN CASE FOR COMPELLING REASONS BHEL ACCEPTS THE OFFER WITHOUT ACCEPTANCE OF THIS CLAUSE BY THE BIDDER AND IN THE EVENTUALITY OF RISK PURCHASE, APPROPRIATE ACTION WILL BE TAKEN AS PER BHEL EXTANT RULES. THIS WILL BE WITHOUT PREJUDICE TO ANY OTHER RIGHT OF BHEL UNDER THE CONTRACT OR UNDER GENERAL LAW.

IN CASE OF BREACH OF CONTRACT, WHEREVER THE VALUE OF SECURITY INSTRUMENTS LIKE PERFORMANCE BANK GUARANTEE AVAILABLE WITH BHEL AGAINST THE SAID CONTRACT IS ATLEAST 10% OF THE CONTRACT VALUE, THE SAME BE ENCASHED. IN CASE THE VALUE OF THE SECURITY INSTRUMENTS AVAILABLE IS LESS THAN 10% OF THE CONTRACT VALUE, THE BALANCE AMOUNT BE RECOVERED FROM OTHER FINANCIAL REMEDIES (I.E. AVAILABLE BILLS OF THE CONTRACTOR, RETENTION AMOUNT, ETC. WITH BHEL) OR LEGAL REMEDIES BE PURSUED.

5. ACTION AGAINST BIDDERS / VENDOR / SUPPLIER / CONTRACTOR IN CASE OF DEFAULT:

IN ORDER TO PROTECT THE COMMERCIAL INTERESTS OF BHEL, BHEL SHALL TAKE ACTION AGAINST SUPPLIES / CONTRACTORS BY WAY OF SUSPENSION OF BUSINESS DEALINGS, WHO EITHER FAIL TO PERFORM OR ARE IN DEFAULT WITHOUT ANY REASONABLE CAUSE, CAUSE LOSS OF BUSINESS/ MONEY/ REPUTATION, INDULGE IN MALPRACTICES, CHEATING, BRIBERY, FRAUD OR ANY OTHER MISCONDUCT OR FORMATION OF CARTELS SO AS TO INFLUENCE THE BIDDING PROCESS OR INFLUENCE THE PRICE ETC.

SUSPENSION OF BUSINESS DEALINGS COULD BE IN THE FORM OF "HOLD" OR "BANNING" A SUPPLIER/ CONTRACTOR OR A BIDDER AND SHALL BE AS PER "GUIDELINES FOR SUSPENSION OF BUSINESS DEALINGS WITH SUPPLIERS/ CONTRACTORS" AVAILABLE AT BHEL'S WEBSITE <https://www.bhel.com/guidelines-suspension-business-dealings-supplierscontractors>

6. BIDDERS ARE ADVISED TO CHECK APPLICABLE GST ON THEIR OWN BEFORE QUOTING. BUYER WILL NOT TAKE ANY RESPONSIBILITY IN THIS REGARDS. GST REIMBURSEMENT WILL BE AS PER ACTUALS OR AS PER APPLICABLE RATES (WHICHEVER IS LOWER), SUBJECT TO THE MAXIMUM OF QUOTED GST %.

7. BIDDER SHALL SUBMIT THE FOLLOWING DOCUMENTS ALONG WITH THEIR BID FOR VENDOR CODE CREATION:

A. COPY OF PAN CARD B. COPY OF GSTIN C. COPY OF MSE CERIFICATE

8. DEDICATED /TOLL FREE TELEPHONE NO. FOR SERVICE SUPPORT: BIDDER/OEM MUST HAVE DEDICATED/TOLL FREE TELEPHONE NO. FOR SERVICE SUPPORT.

9. DATA SHEET OF THE PRODUCT(S) OFFERED IN THE BID, ARE TO BE UPLOADED ALONG WITH THE BID DOCUMENTS. BUYERS CAN MATCH AND VERIFY THE DATA SHEET WITH THE PRODUCT SPECIFICATIONS OFFERED. IN CASE OF ANY UNEXPLAINED MISMATCH OF TECHNICAL PARAMETERS, THE BID IS LIABLE FOR REJECTION.

10. SCOPE OF SUPPLY (BID PRICE TO INCLUDE ALL COST COMPONENTS): ONLY SUPPLY OF GOODS.

11. PRODUCTS SUPPLIED SHALL BE NONTOXIC AND HARMLESS TO HEALTH. IN THE CASE OF TOXIC MATERIALS, MATERIAL SAFETY DATA SHEET MAY BE FURNISHED ALONG WITH THE MATERIAL.

12. WHILE GENERATING INVOICE IN GEM PORTAL, THE SELLER MUST UPLOAD SCANNED COPY OF GST INVOICE AND THE SCREENSHOT OF GST PORTAL CONFIRMING PAYMENT OF GST.

13. PAYMENT TERMS SHALL BE AS PER FOLLOWINGS:

a) **FOR NON-MSES BIDDER:** 100% payment along with taxes, freight & insurance will be made after receipt and acceptance of material and within 90 days from the date of invoice subject to submission of non-discrepant documents within 15 days of supply as per terms and conditions of Purchase Order (THIS IS IN SUPERSESSION OF 10 DAYS' TIME AS PROVIDED IN CLAUSE 12 OF GEM GTC).

b) **FOR MSES BIDDER:** For MSEs (covered under MSME Act) which are registered and periodically renewed with BHEL, the payment will be made within 45 days or as prescribed in the relevant act. Benefits of MSE (such as EMD Waiver, Tender fee exemption, Price preference, Payment preference etc.) will be given only to those MSE Vendors who are manufacturers of offered items against the NIT.

No MSE benefits shall be provided to Agents / Stockists /Dealers / Traders etc. for the items offered but not manufactured by themselves.”

- c) **FOR MEDIUM ENTERPRISES:** 100% payment along with taxes, freight & insurance will be made after receipt and acceptance of material and within 60 days from the date of invoice subject to submission of non-discrepant documents within 15 days of supply as per terms and conditions of Purchase Order.
- d) Please note that vendor to adhere to the payment terms as per above. No deviation in payment terms shall be accepted. Vendor to submit their offer accordingly.