



REQUIREMENT OF CABLE ASSEMBLY

The Heavy Electricals Equipment Plant (HEEP) located in Haridwar, India is one of the major manufacturing plants of Bharat Heavy Electricals Ltd. The core business of HEEP includes design and manufacture of large steam and gas turbines, turbo generators, Defense Items and so on.

Details of items as below:

SI. NO.	MAT CODE	ITEM DISCREPTION	LOT NO.	Quantity (NOS.)	The Delivery Schedule
1	W97032901034	CABLE ASSEMBLY SIZE: P/N 157617800	1 st	13	DEC 2024
			2 nd	10	DEC 2025
			3 rd	10	DEC 2026

SPECIAL INSTRUCTIONS:

1. ALL VENDORS TO PROVIDE POINT WISE REPLY/CONFIRMATION ALONG WITH RELEVANT SUPPORTING DOCUMENTS TO EACH AND EVERY POINT OF **PRE-QUALIFICATION REQUIREMENT/PQR** FOR ALL ENQUIRY ITEMS. NONCOMPLIANCE OF THESE MAY LEAD TO REJECTION OF OFFER AS THESE ARE ESSENTIAL CONDITION FOR PARTICIPATING IN TENDER ENQUIRY.
2. KINDLY UPLOAD/ATTACH THE SPECIFICATION DETAILS/ CATALOGUE OF OFFERED ITEMS.
3. KINDLY ARRANGE TO SUBMIT TECHNO-COMMERCIAL CHECKLIST ALONG WITH YOUR OFFER.
4. VENDOR TO PROVIDE MATERIAL & DIMENSIONAL TEST CERTIFICATES AS PER ENQUIRY DRAWING ALONG WITH MATERIAL SUPPLY.
5. VENDOR TO PROVIDE CERTIFICATE OF CONFORMANCE.
6. VENDOR TO PROVIDE CO-RELATION OF ALL TEST CERTIFICATES AS PER SPECIFICATION.
7. VENDOR TO PROVIDE NON-REMOVABLE IDENTIFICATION OF ALL ITEMS AND THEIR REPORT ACCORDINGLY.
8. EARLY DELIVERY IS ACCEPTABLE FROM OCTOBER 2024 (FOR 1ST LOT).
9. EARLY DELIVERY IS ACCEPTABLE FROM OCTOBER 2025 (FOR 2ND LOT).
10. EARLY DELIVERY IS ACCEPTABLE FROM OCTOBER 2026 (FOR 3RD LOT).

QUALIFYING CONDITIONS for STEEL CABLE SLINGS

Only those manufacturers or authorized dealer/distributor of Original Equipment Manufacturers, should quote:

Sl.	PQR Requirement	Vendor Response	Vendor Response (Yes / No / Enclosed)
1.	Who has experience in manufacturing & supplying STEEL CABLE SLINGS of various sizes.	Vendor to confirm	
2.	who can manufacture / supply Steel Cable Slings as per BHEL drawing.	Vendor to confirm	

00881718800
DRAWING NO.

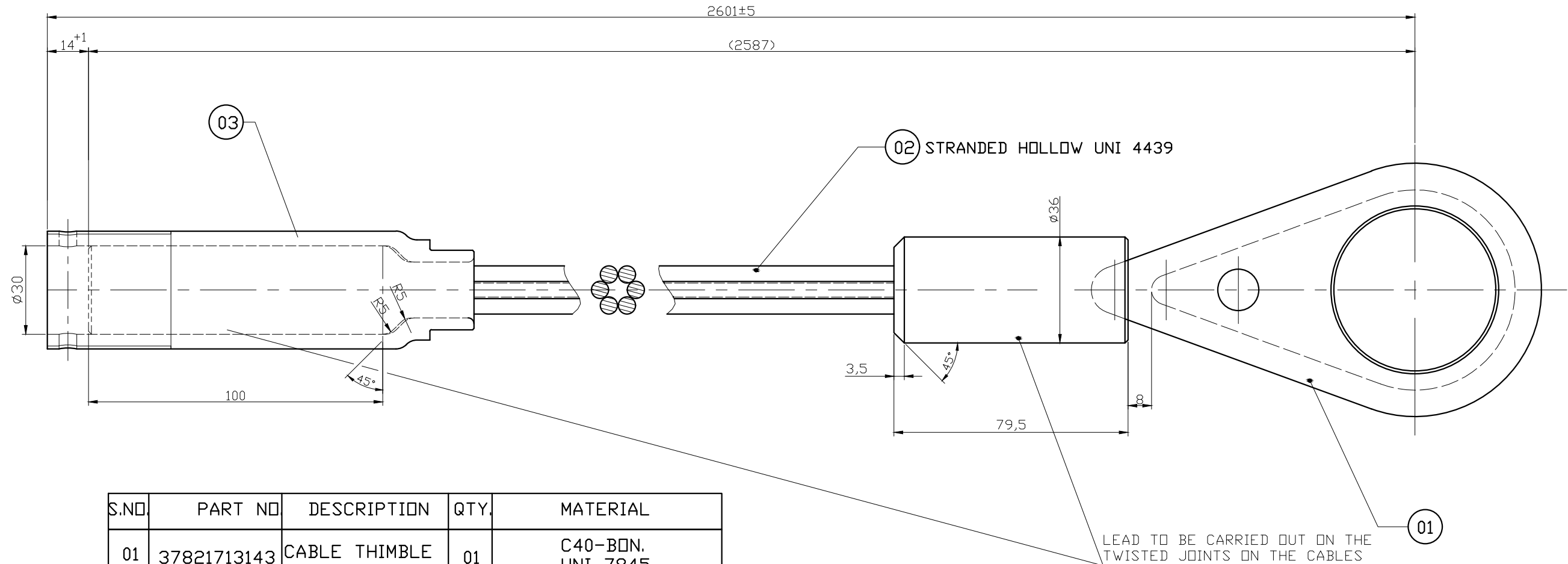

S.NO.	PART NO.	DESCRIPTION	QTY.	MATERIAL
01	37821713143	CABLE THIMBLE	01	C40-BON. UNI 7845
02	-----	3 POLE CABLE	01	Ø18 / 160 - UNI 4439 STRAND HOLLOW WITH 222 FIU
03	37821713144	SLEEVE	01	C40-BON. UNI 5332

NOTE:-
SUBJECT EACH CABLE TO PULL TEST BY APPLYING A FORCE OF 10000 KG. FOR A DURATION OF 15 MIN.

TECH. REQ:-
1. IDENTIFICATION AS PER HW0400397.

GENERAL TOLERANCES LINEAR DIMENSIONS UP TO 18 ±0.15 > 18 TO 80 ±0.25 > 80 ±0.4 ANGLES ±30'	CASTING TOLERANCES LINEAR DIMENSIONS ±(0.5%+1MM) THICKNESS ±8% (MIN. ±0.5mm) ANGLES ±2'	FORGING TOLERANCES LINEAR DIMENSIONS UP TO 18 +0.5-0.3 > 18 TO 80 +1 -0.5 > 80 +2 -0.8 ANGLES ±1'	UNLESS OTHERWISE SPECIFIED ROUND EDGES 0.3 AND CHAMFER 0.3x45° SURFACE MARKED --- REQUIRE STOCK MATERIAL TO BE REMOVED AT ASSEMBLY
--	--	---	---

GMS NO./GRSP NO. -----	STATUS OF DRG. -----	TYPE OF PRODUCT OR NAME OF CUSTOMER/PROJECT	SRGM 76/62
---------------------------	-------------------------	---	-------------------

DRN. NAME SANDEEP	SIGN. sd/-	DATE 21.02.24	NO. OF VAR. -
CHD. RAVINDER	sd/-	21.02.24	-
APPD. SK SINGH	sd/-	21.02.24	-

DEPT. DPE	SCALE NTS	WEIGHT (KG) 7.3	REF. TO ASSY DRG. -----	ITEM NO. -	NO. OF ITEMS -
-----------	-----------	-----------------	-------------------------	------------	----------------

TITLE BALANCER CABLE	DRAWING NO. 27821718800	REV. -
--------------------------------	-----------------------------------	--------

AGREED DEPT. DABG-T	NAME SUMIT	SIGN SD/-	DATE ***
GRADE OF UNTOL.DIM :- M/CG-7/M/F-AA0230208 WELDING A/B/C/D-AA0621104 GAS CUTTING-T3-AA0621101			
REV.	DATE	ALTERED CHECKED	ZONE

PROPRIETARY DATA OF DTD MELARA SPA
 LIMITED RIGHTS OF TECHNICAL DATA
 THE TECHNICAL DATA SET FORTH HEREIN IS SUBJECT TO THE TERMS AND CONDITIONS OF THE LICENSE AGREEMENT BETWEEN DTD MELARA SPA AND BHARAT HEAVY ELECTRICALS LTD
 THE TECHNICAL DATA CONTAINED HEREIN IS RESTRICTED AS TO USE, DUPLICATION OR DISCLOSURE AS PER TERMS AND CONDITIONS OF THE LICENSE AGREEMENT
 INVENTORY NO. SIGN & DATE 157617800-01 REF. DRG. NO.

PROPRIETARY DATA OF DTD MELARA SPA
 LIMITED RIGHTS OF TECHNICAL DATA
 THE LICENSE AGREEMENT BETWEEN DTD MELARA SPA AND BHARAT HEAVY ELECTRICALS LTD.
 THE TECHNICAL DATA CONTAINED HEREIN IS RESTRICTED AS TO USE, DUPLICATION OR
 DISCLOSURE AS PER TERMS AND CONDITIONS OF THE LICENSE AGREEMENT.

137617143-01
 REF. DRG. NO.

SIGN & DATE

INVENTORY NO.

FIRST ANGLE PROJECTION

(ALL DIMENSIONS ARE IN mm)

FORM DG38(B)

3.2/ALL OVER UNLESS
 OTHERWISE STATED

DRAWING NO.
37821713143

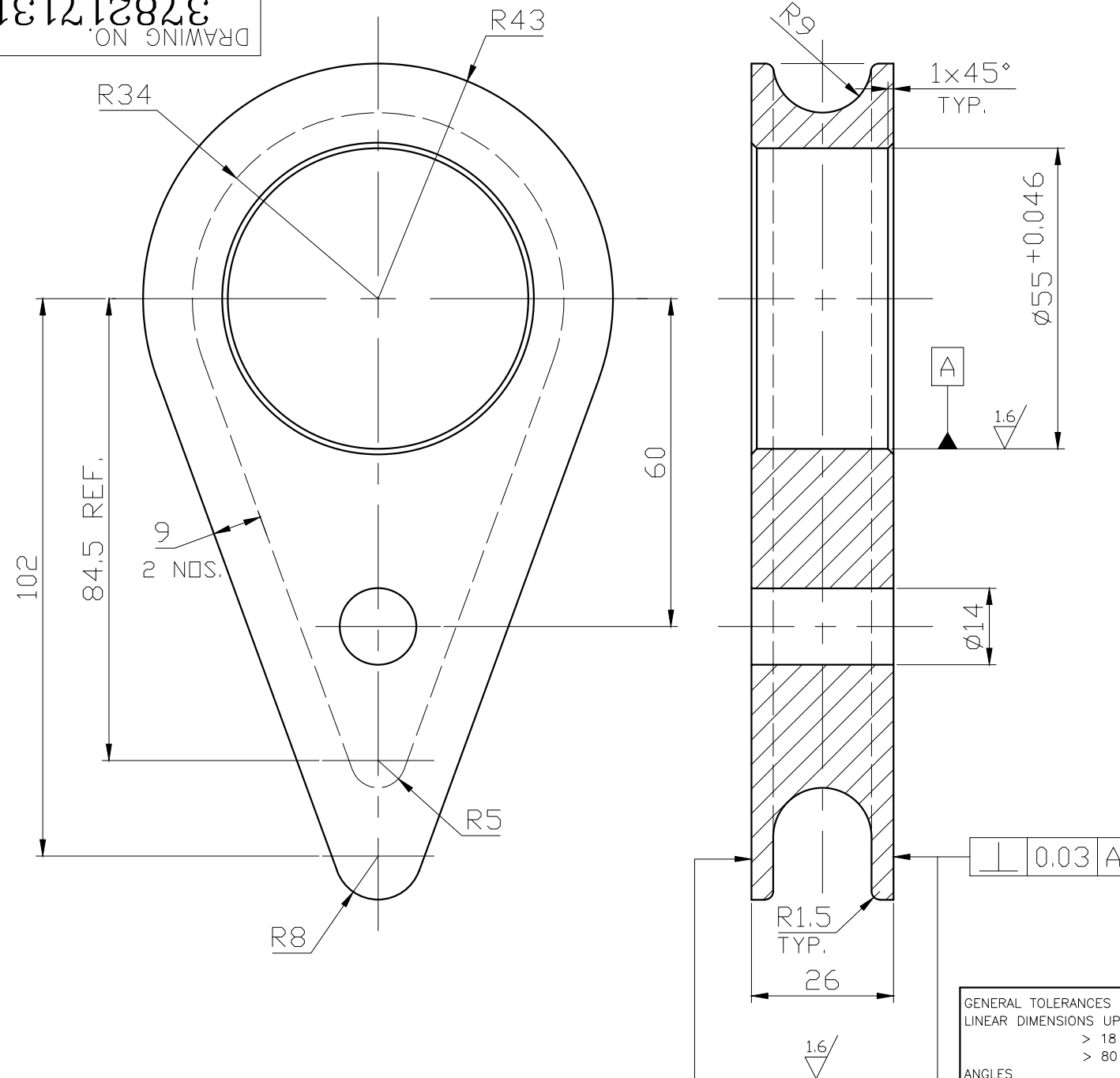

TECHNICAL REQUIREMENTS

- IDENTIFICATION AS PER HW0400397
- FINAL PROTECTIVE COATING AS PER HW0986097 (RS 10.1.1), COATING THICKNESS = 2-7 MICRONS.

GENERAL TOLERANCES LINEAR DIMENSIONS UP TO 18 ±0.15 > 18 TO 80 ±0.25 > 80 ±0.4 ANGLES ±30'	CASTING TOLERANCES LINEAR DIMENSIONS ±(0.5%+1MM) THICKNESS ±8% (MIN. ±0.5mm) ANGLES ±2'	FORGING TOLERANCES LINEAR DIMENSIONS UP TO 18 +0.5-0.3 > 18 TO 80 +1 -0.5 > 80 +2 -0.8 ANGLES ±1'	UNLESS OTHERWISE SPECIFIED ROUND EDGES 0.3 AND CHAMFER 0.3x45° SURFACE MARKED --- REQUIRE STOCK MATERIAL TO BE REMOVED AT ASSEMBLY
---	---	--	--

GMS NO./GR SP NO		STATUS OF DRG	
CBOM -----			
AGREED DEPT.	NAME	SIGN	DATE
DABG-T	SUMIT	Sd/-	****
GRADE OF UNTOL DIM :-			
M/CG-C/M/F AA0230208			
WELDING-A/B/C/D AA0621104			
GAS CUTTING-T3'AA0621101			
REV	DATE	ALTERED	CHECKED

TYPE OF PRODUCT OR NAME OF CUSTOMER/PROJECT		SRGM 76/62			
BHARAT HEAVY ELECTRICALS LTD. HARDWAR		DRN	NAME	SIGN	DATE
		CHD	RAVENDER	sd/-	21.02.24
		APD	SK SINGH	sd/-	21.02.24
DEPT DPE	SCALE	WEIGHT (kg)	REF TO ASSY DRG.		ITEM NO
CODE 4260	NTS	0.8	-----		NO OF ITEMS
TITLE		CARD CODE	DRAWING NO.		REV.
CABLE THIMBLE		-	37821713143		-
		SHEET NO. 01		NO.OF SHEETS 01	

FIRST ANGLE PROJECTION

(ALL DIMENSIONS ARE IN mm)

FORM DG38(B)

6.3/ALL OVER UNLESS OTHERWISE STATED

DRAWING NO. 37821713144

PROPRIETARY DATA OF DTD MELARA SPA
 LIMITED RIGHTS OF TECHNICAL DATA
 THE LICENSE AGREEMENT BETWEEN DTD MELARA SPA AND BHARAT HEAVY ELECTRICALS LTD.
 THE TECHNICAL DATA CONTAINED HEREIN IS RESTRICTED AS TO USE, DUPLICATION OR
 DISCLOSURE AS PER TERMS AND CONDITIONS OF THE LICENSE AGREEMENT.

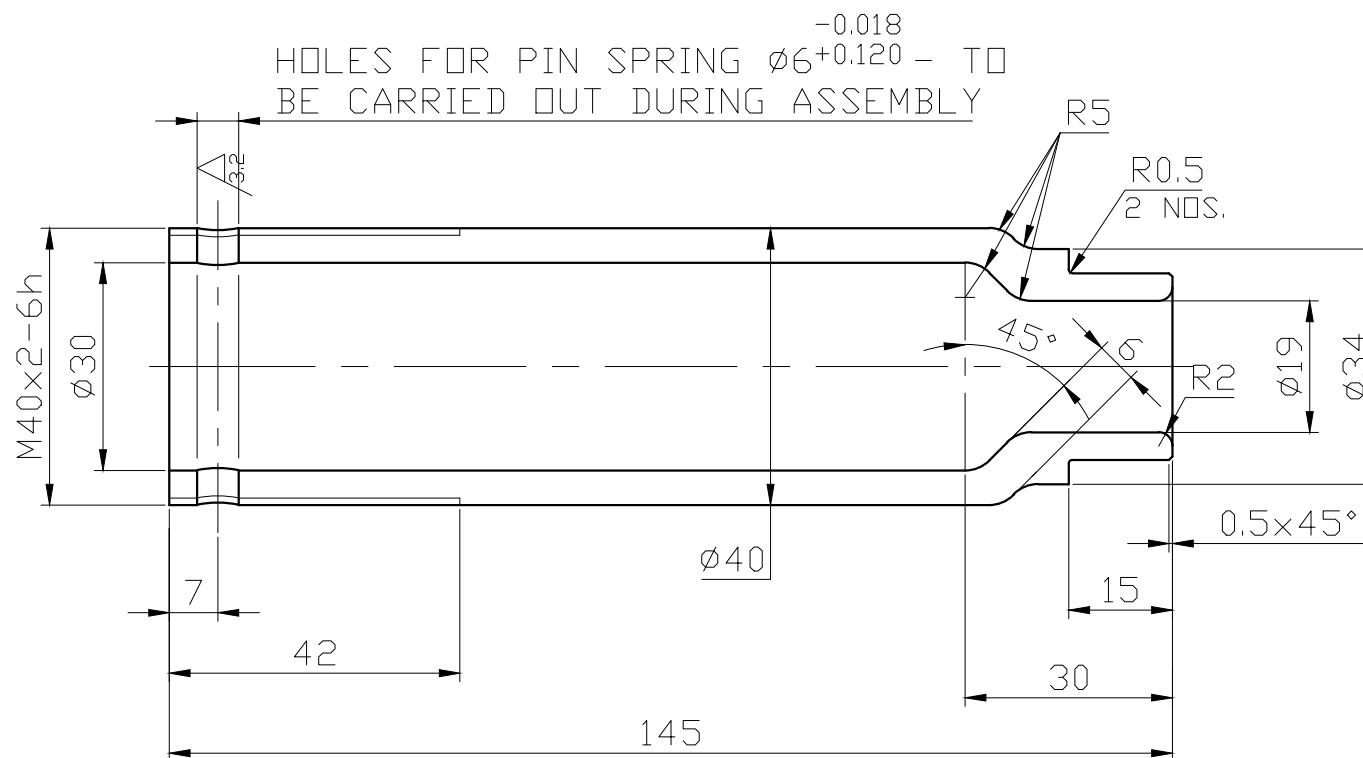
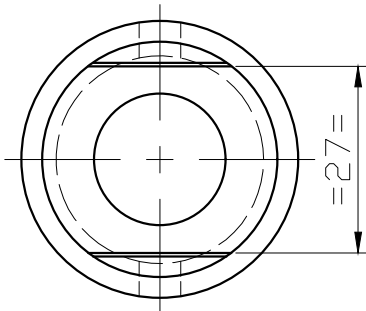

TECHNICAL REQUIREMENTS

- IDENTIFICATION AS PER HW0400397
- FINAL PROTECTIVE COATING AS PER HW0986097 (RS 10.1.2),
 COATING THICKNESS = 8-15 MICRONS.

GENERAL TOLERANCES LINEAR DIMENSIONS UP TO 18 ±0.15 > 18 TO 80 ±0.25 > 80 ±0.4 ANGLES ±30'	CASTING TOLERANCES LINEAR DIMENSIONS ±(0.5%+1MM) THICKNESS ±8% (MIN. ±0.5mm) ANGLES ±2'	FORGING TOLERANCES LINEAR DIMENSIONS UP TO 18 +0.5-0.3 > 18 TO 80 +1 -0.5 > 80 +2 -0.8 ANGLES ±1'	UNLESS OTHERWISE SPECIFIED ROUND EDGES 0.3 AND CHAMFER 0.3x45° SURFACE MARKED --- REQUIRE STOCK MATERIAL TO BE REMOVED AT ASSEMBLY
--	--	---	--

137617144-01
REF. DRG. NO.

SIGN & DATE

INVENTORY NO.

GRADE OF UNTOL DIM :-	
M/CG-C/M/F	AA0230208
WELDING-A/B/C/D	AA0621104
GAS CUTTING-T3	AA0621101

REV	DATE	ALTERED
		CHECKED

GMS NO./GR SP NO		STATUS OF DRG	
CBOM -----			
AGREED DEPT.	NAME	SIGN	DATE
DABG-T	SUMIT	Sd/-	****

TYPE OF PRODUCT
OR
NAME OF CUSTOMER/PROJECT

SRGM 76/62

BHARAT HEAVY ELECTRICALS LTD.
HARDWAR

DRN	NAME	SIGN	DATE	NO. OF VAR.
CHD	RAVENDER	sd/-	21.02.24	-
APD	SK SINGH	sd/-	21.02.24	-

DEPT DPE
CODE 4260

SCALE
NTS

WEIGHT (kg)
0.6

REF TO ASSY DRG.

ITEM NO
-

No of ITEMS
-

TITLE
SLEEVE

CARD CODE
-

DRAWING NO.
37821713144

REV.
-

SHEET NO. 01 | NO.OF SHEETS 01

MAKE IN INDIA SELF CERTIFICATION

As per Government Public procurement order no. P-45021/2/2017-BE-II dt.15.06.2017 & P45021/2/2017-PP(BE-II) dated 28.05.2018,29.5.2019, 04.6.2020 and amendment dated 16.09.2020, it is hereby certifying that we

.....
..... (supplier name) are(Class-I/Class-II)
local supplier and will meet the requirement of minimum local content of
(50%/20%) as defined in public procurement order dated 04.6.2020 for material against Enquiry no.
..... Details of
location at which local value addition will be made is as follows: -
.....
.....
.....

We also understand, false declarations will be in breach of the code of integrity under Rule 175(1)(i)(h) of the General Financial Rules for which a bidder or its successors can be debarred for up to two years as per Rule 151 (iii) of the general financial rules along with such other actions as may be permissible under law.

Note:

As per office order P-45021/102/2019-BE-II-Part (1) (E-50310) Dated 04/03/2021, Bidders can't claim itself as "Class-I local supplier/Class-II local suppliers" by claiming the service such as transportation, insurance, installation, commissioning, training & after sales service support like AMC/CMC etc. as local value addition. Bidder offering imported product will fall under the category of Non-Local supplier.

TECHNO-COMMERCIAL CHECKLIST

SL. NO.	TERMS & CONDITION	VENDOR CONFIRMATION /REMARKS / REPLY
TENDER DETAILS		
1	BIDDER NAME	
2	GEM BID NO	
QUALITY & TECHNICAL REMARKS		
3	VENDOR TO CONFIRM TO PROVIDE MATERIAL & DIMENSIONAL TEST CERTIFICATES AS PER ENQUIRY DRAWING ALONG WITH MATERIAL SUPPLY	
4	VENDOR TO CONFIRM TO PROVIDE CERTIFICATE OF CONFORMANCE ALONG WITH MATERIAL SUPPLY	
5	VENDOR TO CONFIRM ENSURE CO-RELATION OF ALL TEST CERTIFICATES AS PER SPECIFICATION .	
6	VENDOR TO CONFIRM PROVIDE NON-REMOVABLE IDENTIFICATION OF ALL ITEMS AND THEIR REPORT ACCORDINGLY .	
COMMERICAL REMARKS		
7	ITEM IS TO BE SUPPLIED AS PER TECHNICAL SPECIFICATION/DRAWING	
	<p>VENDOR TO CONFIRM THAT DELIVERY SHALL BE IN STAGGERED MANNER AS PER BELOW:</p> <p>1st LOT:DEC 2024</p> <p>2nd LOT:DEC 2025</p> <p>3rd LOT:DEC 2026</p>	
8	KINDLY SUBMIT MAKE IN INDIA CERTIFICATE.	
9	KINDLY UPLOAD/ATTACH THE SPECIFICATION DETAILS/ CATALOGUE OF OFFERED ITEMS.	
10	<p>RISK PURCHASE: IN CASE OF ABNORMAL DELAYS (BEYOND THE MAXIMUM LATE DELIVERY PERIOD AS PER LD CLAUSE) IN SUPPLIES / DEFECTIVE SUPPLIES OR NONFULFILLMENT OF ANY OTHER TERMS AND CONDITIONS GIVEN IN PURCHASE ORDER, BHEL MAY CANCEL THE PURCHASE ORDER IN FULL OR PART THEREOF, AND MAY ALSO MAKE THE PURCHASE OF SUCH MATERIAL FROM ELSEWHERE / ALTERNATIVE SOURCE AT THE RISK AND COST OF THE SUPPLIER. BHEL WILL TAKE ALL REASONABLE STEPS TO GET THE MATERIAL FROM ALTERNATE SOURCE AT OPTIMUM COST. IF BIDDER DOES NOT AGREE TO THE ABOVE RISK PURCHASE CLAUSE, BHEL RESERVES THE RIGHT TO REJECT THE OFFER. IN CASE FOR COMPELLING REASONS BHEL ACCEPTS THE OFFER WITHOUT ACCEPTANCE OF THIS CLAUSE BY THE BIDDER AND IN THE EVENTUALITY OF RISK PURCHASE, APPROPRIATE ACTION WILL BE TAKEN AS PER BHEL EXTANT RULES. THIS WILL BE WITHOUT PREJUDICE TO ANY OTHER RIGHT OF BHEL UNDER THE CONTRACT OR UNDER GENERAL LAW.</p> <p>IN CASE OF BREACH OF CONTRACT, WHEREVER THE VALUE OF SECURITY INSTRUMENTS LIKE PERFORMANCE BANK GUARANTEE AVAILABLE WITH BHEL AGAINST THE SAID CONTRACT IS ATLEAST 10% OF THE CONTRACT VALUE, THE SAME BE ENCASHED. IN CASE THE VALUE OF THE SECURITY INSTRUMENTS AVAILABLE IS LESS THAN 10% OF THE CONTRACT VALUE, THE BALANCE AMOUNT BE RECOVERED FROM OTHER FINANCIAL REMEDIES (I.E. AVAILABLE BILLS OF THE CONTRACTOR, RETENTION AMOUNT, ETC. WITH BHEL) OR LEGAL REMEDIES BE PURSUED.</p>	
11	<p>ACTION AGAINST BIDDERS / VENDOR / SUPPLIER / CONTRACTOR IN CASE OF DEFAULT: IN ORDER TO PROTECT THE COMMERCIAL INTERESTS OF BHEL, BHEL SHALL TAKE ACTION AGAINST SUPPLIES / CONTRACTORS BY WAY OF SUSPENSION OF BUSINESS DEALINGS, WHO EITHER FAIL TO PERFORM OR ARE IN DEFAULT WITHOUT ANY REASONABLE CAUSE, CAUSE LOSS OF BUSINESS/ MONEY/ REPUTATION, INDULGE IN MALPRACTICES, CHEATING, BRIBERY, FRAUD OR ANY OTHER MISCONDUCT OR FORMATION OF CARTELS SO AS TO INFLUENCE THE BIDDING PROCESS OR INFLUENCE THE PRICE ETC.</p> <p>SUSPENSION OF BUSINESS DEALINGS COULD BE IN THE FORM OF "HOLD" OR "BANNING" A SUPPLIER/ CONTRACTOR OR A BIDDER AND SHALL BE AS PER "GUIDELINES FOR SUSPENSION OF BUSINESS DEALINGS WITH SUPPLIERS/ CONTRACTORS" AVAILABLE AT BHEL'S WEBSITE "https://www.bhel.com/guidelines-suspension-business-dealings-supplierscontractors"</p>	
12	REST GENEREL TERMS AND CONDITIONS AS PER GeM	

1. ALL VENDORS TO PROVIDE POINT WISE REPLY/CONFIRMATION ALONG WITH RELEVANT SUPPORTING DOCUMENTS TO EACH AND EVERY POINT OF **PRE-QUALIFICATION REQUIREMENT/PQR** FOR ALL ENQUIRY ITEMS. NONCOMPLIANCE OF THESE MAY LEAD TO REJECTION OF OFFER AS THESE ARE ESSENTIAL CONDITION FOR PARTICIPATING IN TENDER ENQUIRY.
2. KINDLY UPLOAD/ATTACH THE SPECIFICATION DETAILS/ CATALOGUE OF OFFERED ITEMS.
3. KINDLY ARRANGE TO **SUBMIT TECHNO-COMMERCIAL CHECKLIST** ALONG WITH YOUR OFFER.
4. VENDOR TO PROVIDE MATERIAL & DIMENSIONAL TEST CERTIFICATES AS PER ENQUIRY DRAWING ALONG WITH MATERIAL SUPPLY.
5. VENDOR TO PROVIDE CERTIFICATE OF CONFORMANCE.
6. VENDOR TO PROVIDE CO-RELATION OF ALL TEST CERTIFICATES AS PER SPECIFICATION.
7. VENDOR TO PROVIDE NON-REMOVABLE IDENTIFICATION OF ALL ITEMS AND THEIR REPORT ACCORDINGLY.
8. DELIVERY SHALL BE IN STAGGERED MANNER AS PER BELOW TABLE:

Sl. NO.	MAT CODE	ITEM DISCREPTION	LOT NO.	Quantity (NOS.)	The Delivery Schedule
1	W97032901034	CABLE ASSEMBLY SIZE: P/N 157617800	1 st	13	DEC 2024
			2 nd	10	DEC 2025
			3 rd	10	DEC 2026

9. EARLY DELIVERY IS ACCEPTABLE FROM OCTOBER 2024 (FOR 1ST LOT).
10. EARLY DELIVERY IS ACCEPTABLE FROM OCTOBER 2025 (FOR 2ND LOT).
11. EARLY DELIVERY IS ACCEPTABLE FROM OCTOBER 2026 (FOR 3RD LOT).
12. MSE/MII: THE SUPPLIER NEEDS TO SUBMIT/UPDATE MSE/MII CREDENTIALS ON GEM PORTAL DURING PROFILE UPDATION/ OFFER SUBMISSION STAGE. THE MSE DATA SUBMITTED IS CROSS VERIFIED BY GEM WITH GOVT. OF INDIA UDYAM/NSIC DATABASE THROUGH API INTEGRATION ON REAL TIME BASIS AND FOR MII, A SELF DECLARATION IS BEING GIVEN AND AUTHENTICATED BY AADHAR OTP. IF THE SELLER FAILS TO CLAIM MSE/MII PROVISION ON GEM PORTAL AT PROFILE UPDATION/BID SUBMISSION STAGE, THE SAID SELLER WILL BECOME INELIGIBLE FOR GETTING THE MSE/MII BENEFITS FOR THAT BID AUTOMATICLLY. THE VENDOR CAN ALWAYS CONTACT THE GEM HELPDESK, IN CASE OF ANY ISSUES.
13. KINDLY SUBMIT MAKE INDIA CERTIFICATE.
14. THE PRICE QUOTE BY BIDDER SHOULD BE INCLUSIVE OF GST & SHOULD BE ON BHEL HEEP HARIDWAR STORES BASIS.
15. BIDDER'S OFFER IS LIABLE TO BE REJECTED IF THEY DON'T UPLOAD ANY OF THE CERTIFICATES / DOCUMENTS SOUGHT IN THE BID DOCUMENT, ATC AND CORRIGENDUM IF ANY.
16. **RISK PURCHASE:**
IN CASE OF ABNORMAL DELAYS (BEYOND THE MAXIMUM LATE DELIVERY PERIOD AS PER LD CLAUSE) IN SUPPLIES / DEFECTIVE SUPPLIES OR NONFULFILLMENT OF ANY OTHER TERMS AND CONDITIONS GIVEN IN PURCHASE ORDER, BHEL MAY CANCEL THE PURCHASE ORDER IN FULL OR PART THEREOF, AND MAY ALSO MAKE THE PURCHASE OF SUCH MATERIAL FROM ELSEWHERE / ALTERNATIVE SOURCE AT THE RISK AND COST OF THE SUPPLIER. BHEL WILL TAKE ALL REASONABLE STEPS TO GET THE MATERIAL FROM ALTERNATE SOURCE AT OPTIMUM COST. IF BIDDER DOES NOT AGREE TO THE ABOVE RISK PURCHASE CLAUSE, BHEL RESERVES THE RIGHT TO REJECT THE OFFER. IN CASE FOR COMPELLING REASONS BHEL ACCEPTS THE OFFER WITHOUT ACCEPTANCE OF THIS CLAUSE BY THE

BIDDER AND IN THE EVENTUALITY OF RISK PURCHASE, APPROPRIATE ACTION WILL BE TAKEN AS PER BHEL EXTANT RULES. THIS WILL BE WITHOUT PREJUDICE TO ANY OTHER RIGHT OF BHEL UNDER THE CONTRACT OR UNDER GENERAL LAW.

IN CASE OF BREACH OF CONTRACT, WHEREVER THE VALUE OF SECURITY INSTRUMENTS LIKE PERFORMANCE BANK GUARANTEE AVAILABLE WITH BHEL AGAINST THE SAID CONTRACT IS ATLEAST 10% OF THE CONTRACT VALUE, THE SAME BE ENCASHED. IN CASE THE VALUE OF THE SECURITY INSTRUMENTS AVAILABLE IS LESS THAN 10% OF THE CONTRACT VALUE, THE BALANCE AMOUNT BE RECOVERED FROM OTHER FINANCIAL REMEDIES (I.E. AVAILABLE BILLS OF THE CONTRACTOR, RETENTION AMOUNT, ETC. WITH BHEL) OR LEGAL REMEDIES BE PURSUED.

17. ACTION AGAINST BIDDERS / VENDOR / SUPPLIER / CONTRACTOR IN CASE OF DEFAULT:

IN ORDER TO PROTECT THE COMMERCIAL INTERESTS OF BHEL, BHEL SHALL TAKE ACTION AGAINST SUPPLIES / CONTRACTORS BY WAY OF SUSPENSION OF BUSINESS DEALINGS, WHO EITHER FAIL TO PERFORM OR ARE IN DEFAULT WITHOUT ANY REASONABLE CAUSE, CAUSE LOSS OF BUSINESS/ MONEY/ REPUTATION, INDULGE IN MALPRACTICES, CHEATING, BRIBERY, FRAUD OR ANY OTHER MISCONDUCT OR FORMATION OF CARTELS SO AS TO INFLUENCE THE BIDDING PROCESS OR INFLUENCE THE PRICE ETC.

SUSPENSION OF BUSINESS DEALINGS COULD BE IN THE FORM OF "HOLD" OR "BANNING" A SUPPLIER/ CONTRACTOR OR A BIDDER AND SHALL BE AS PER "GUIDELINES FOR SUSPENSION OF BUSINESS DEALINGS WITH SUPPLIERS/ CONTRACTORS" AVAILABLE AT BHEL'S WEBSITE <https://www.bhel.com/guidelines-suspension-business-dealings-supplierscontractors>

18. BIDDERS ARE ADVISED TO CHECK APPLICABLE GST ON THEIR OWN BEFORE QUOTING. BUYER WILL NOT TAKE ANY RESPONSIBILITY IN THIS REGARDS. GST REIMBURSEMENT WILL BE AS PER ACTUALS OR AS PER APPLICABLE RATES (WHICHEVER IS LOWER), SUBJECT TO THE MAXIMUM OF QUOTED GST %.

19. BIDDER SHALL SUBMIT THE FOLLOWING DOCUMENTS ALONG WITH THEIR BID FOR VENDOR CODE CREATION:

A. COPY OF PAN CARD B. COPY OF GSTIN C. COPY OF MSE CERIFICATE

20. DEDICATED /TOLL FREE TELEPHONE NO. FOR SERVICE SUPPORT: BIDDER/OEM MUST HAVE DEDICATED/TOLL FREE TELEPHONE NO. FOR SERVICE SUPPORT.

21. DATA SHEET OF THE PRODUCT(S) OFFERED IN THE BID, ARE TO BE UPLOADED ALONG WITH THE BID DOCUMENTS. BUYERS CAN MATCH AND VERIFY THE DATA SHEET WITH THE PRODUCT SPECIFICATIONS OFFERED. IN CASE OF ANY UNEXPLAINED MISMATCH OF TECHNICAL PARAMETERS, THE BID IS LIABLE FOR REJECTION.

22. SCOPE OF SUPPLY (BID PRICE TO INCLUDE ALL COST COMPONENTS): ONLY SUPPLY OF GOODS.

23. PRODUCTS SUPPLIED SHALL BE NONTOXIC AND HARMLESS TO HEALTH. IN THE CASE OF TOXIC MATERIALS, MATERIAL SAFETY DATA SHEET MAY BE FURNISHED ALONG WITH THE MATERIAL.

24. WHILE GENERATING INVOICE IN GEM PORTAL, THE SELLER MUST UPLOAD SCANNED COPY OF GST INVOICE AND THE SCREENSHOT OF GST PORTAL CONFIRMING PAYMENT OF GST.

25. PAYMENT TERMS SHALL BE AS PER FOLLOWINGS:

a) **FOR NON-MSES BIDDER:** 100% payment along with taxes, freight & insurance will be made after receipt and acceptance of material and within 90 days from the date of invoice subject to submission of non-discrepant documents within 15 days of supply as per terms and conditions of Purchase Order (THIS IS IN SUPERSESION OF 10 DAYS' TIME AS PROVIDED IN CLAUSE 12 OF GEM GTC).

b) **FOR MSES BIDDER:** For MSEs (covered under MSME Act) which are registered and periodically renewed with BHEL, the payment will be made within 45 days or as prescribed in the relevant act.

Benefits of MSE (such as EMD Waiver, Tender fee exemption, Price preference, Payment preference etc.) will be given only to those MSE Vendors who are manufacturers of offered items against the NIT. No MSE benefits shall be provided to Agents / Stockists /Dealers / Traders etc. for the items offered but not manufactured by themselves.”

- c) **FOR MEDIUM ENTERPRISES:** 100% payment along with taxes, freight & insurance will be made after receipt and acceptance of material and within 60 days from the date of invoice subject to submission of non-discrepant documents within 15 days of supply as per terms and conditions of Purchase Order.
- d) Please note that vendor to adhere to the payment terms as per above. No deviation in payment terms shall be accepted. Vendor to submit their offer accordingly.