



Bharat Heavy Electricals Limited

(High Pressure Boiler Plant)

Tiruchirappalli – 620014, TAMIL NADU, INDIA

CAPITAL PURCHASE / MATERIALS MANAGEMENT / MANUFACTURING

An ISO 9001
Company

ENQUIRY	Phone: +91 431 257 79 38 Fax : +91 431 252 07 19 Email : tvenkat@bheltry.co.in Web : www.bhel.com
----------------	---

	Enquiry Number: 2620700079	Enquiry Date: 17.08.2007	Due date for submission of quotation: 29.09.2007
--	---	---	---

You are requested to quote the Enquiry number date and due date in all your correspondences. This is only a request for quotation and not an order

Item	Description	Quantity	Delivery (Item required at BHEL on)
10	Hydraulic Tube End Swaging and Upsetting Machine as per the technical specification & commercial conditions applicable (to be downloaded from web site www.bhel.com or http://tenders.gov.in)	1 No.	30.09.2008

BHEL commercial terms & conditions with Price Bid and Bank Guarantee formats along with technical specifications can be downloaded from BHEL web site <http://www.bhel.com> or from the Government tender website <http://tenders.gov.in> (public sector units > Bharat Heavy Electricals Limited page) under Enquiry reference “2620700079”.

Tenders should reach us before 14:00 hours on the due date
Tenders will be opened at 14:30 hours on the due date
Tenders would be opened in presence of the tenderers who have submitted their offers and who may like to be present

Yours faithfully,
For BHARAT HEAVY ELECTRICALS LIMITED
Manager / Capital Purchase / MM / Manufacturing

PART A**SECTION – I QUALIFYING CRITERIA**

The Bidder / Vendor (OEM) has to compulsorily meet the following requirements to get qualified for consideration of the technical offer for the HYDRAULIC TUBE END SWAGING AND UPSETTING MACHINE.

S.No	REQUIREMENTS	VENDOR's COMMENTS
1.0	The Bidder / Vendor (OEM) shall have a minimum of TEN Years of Continuous Experience in the field of Design, Manufacture and Supply of HYDRAULIC TUBE SWAGING MACHINES	
2.0	Only those vendors (OEMs), who have supplied and commissioned at least ONE HYDRAULIC TUBE SWAGING MACHINE in the past ten years (on the date of opening of Tender) and such machine is presently working satisfactorily for more than one year after commissioning (on the date of opening of Tender), should quote. However, if such machine (s) has/ had been supplied to BHEL, then such machine should be presently working satisfactorily for more than six months after its commissioning and acceptance (on the date of opening of Tender) in BHEL. Performance certificate from the customers regarding satisfactory performance of HYDRAULIC TUBE SWAGING MACHINE supplied to them in attached format to be enclosed along with technical offer.	
3.0	BHEL reserves the right to verify the information provided by vendor. In case the information provided by vendor is found to be false/ incorrect, the offer shall be rejected.	

SECTION – II

The Bidder / Vendors are requested to provide the following details

S.No	PARTICULARS	VENDOR'S RESPONSE
4.0	Number of Years of Experience of the Bidder / Vendor in the field of design, manufacture, supply, erection & commissioning of HYDRAULIC TUBE SWAGING MACHINE	
5.0	Number of HYDRAULIC TUBE SWAGING MACHINE supplied, installed and commissioned till date (with details on machine type / model, configuration, customer and quantity)	
6.0	Details on International Standards / Design Process Codes followed in Design and Manufacture of the Equipment.	
7.0	Details on SERVICE-AFTER-SALES Set-Up in India including the Addresses of Agents / Service Centers in India and competency & Experience of the Local Service Agency are to be provided.	
8.0	Any Additional Data to supplement the manufacturing capability of the BIDDER for the subject equipment.	

SECTION – III

Bidder / Vendor to note the following

S.No	REQUIREMENTS	VENDOR's COMPLIANCE
9.0	The BIDDER / VENDOR shall submit the offer in TWO PARTS -Technical [with PART A & PART B] & Commercial and Price Bid.	
10.0	The Offer shall contain a comparative statement of Technical Specifications given by BHEL and the Offer Details submitted by the Bidder, against each clause. A mere 'CONFIRMED' or 'COMPLIES' or 'YES' or 'NO-DEVIATION' or similar words in the technical comparative statement (without any supporting technical write-ups, photos and datasheets] may lead to disqualification of the Technical Offer.	
11.0	The Technical Offer shall be supported by Product Catalogue and Data Sheets in ORIGINAL and complete technical details of 'Bought-Out-Items' with copies of Product Catalogue and Selection Criteria	
12.0	The Commercial Offer (given with the Technical Offer) shall contain the Scope of Supply and the Un-Priced Part of the Price-Bid, for confirmation	
13.0	BIDDER has to indicate the Country of Origin for the supply of equipment.	

PERFORMANCE CERTIFICATE

(On Customer's Letter Head)

1. Supplier of the machine :

2. Make & Model of the Equipment :

3. Month & Year of Commissioning :

4. Application :

5. Sizes of Jobs Performed in the machine
 - a. Tube diameter :
 - b. Tube thickness :
 - c. Reduction in Tube diameter :
 - d. Swage Length (maximum) :
 - e. Any upsetting is done :

6. Performance of the Machine : Best in the market /
(Strike off whichever is not applicable) Satisfactory /
Good /
Average /
Not Satisfactory

7. Any other remarks:

Date:

Signature & Seal of the Authority
Issuing the Performance Certificate

PART B**TECHNICAL SPECIFICATION FOR HYDRAULIC TUBE END SWAGING AND UPSETTING MACHINE**

S. No.	PARTICULARS	BHEL SPECIFICATIONS	Bidder's OFFER																											
1.0	APPLICATION	<p>A) The machine is meant for Cold Swaging & Hot Upsetting of Tube ends of seamless steel tubes in Horizontal Direction HYDRAULICALLY.</p> <p>B) Swaging is a process of reducing the Tube Outer diameter at the tube ends upto a max. length of 400mm</p> <p>C) Upsetting is a process of increasing the thickness, maintaining the Tube Outer diameter at the tube ends upto a max. length of 60mm.</p>																												
2.0	TUBE SPECIFICATIONS FOR SWAGING & UPSETTING:																													
2.1	TUBE OUTER DIAMETER AND THICKNESS: All are OD (Outer Diameter) Controlled tubes with thickness tolerance of Max.+18 %																													
2.2	<table border="1"> <thead> <tr> <th>S.No</th> <th>Tube OD in mm</th> <th>Tube Thickness in mm</th> </tr> </thead> <tbody> <tr> <td>1</td> <td>38.1</td> <td>4.0 / 5.0 / 6.3</td> </tr> <tr> <td>2</td> <td>44.5</td> <td>4.0 / 4.5 / 5 / 6.3 / 8 / 9 / 10</td> </tr> <tr> <td>3</td> <td>47.63</td> <td>5 / 6.3 / 8 / 10</td> </tr> <tr> <td>4</td> <td>51.0</td> <td>3.6 / 4 / 4.5 / 5 / 6.3 / 8 / 10 / 12</td> </tr> <tr> <td>5</td> <td>54.0</td> <td>3.6 / 4 / 4.5 / 5 / 6.3 / 8 / 10 / 12</td> </tr> <tr> <td>6</td> <td>57.0</td> <td>4 / 5 / 6.3 / 8 / 10</td> </tr> <tr> <td>7</td> <td>63.5</td> <td>4.8 / 5.6 / 6.3 / 10 / 12.5</td> </tr> <tr> <td>8</td> <td>76.1</td> <td>7.1 / 10 / 12.5</td> </tr> </tbody> </table>		S.No	Tube OD in mm	Tube Thickness in mm	1	38.1	4.0 / 5.0 / 6.3	2	44.5	4.0 / 4.5 / 5 / 6.3 / 8 / 9 / 10	3	47.63	5 / 6.3 / 8 / 10	4	51.0	3.6 / 4 / 4.5 / 5 / 6.3 / 8 / 10 / 12	5	54.0	3.6 / 4 / 4.5 / 5 / 6.3 / 8 / 10 / 12	6	57.0	4 / 5 / 6.3 / 8 / 10	7	63.5	4.8 / 5.6 / 6.3 / 10 / 12.5	8	76.1	7.1 / 10 / 12.5	
S.No	Tube OD in mm	Tube Thickness in mm																												
1	38.1	4.0 / 5.0 / 6.3																												
2	44.5	4.0 / 4.5 / 5 / 6.3 / 8 / 9 / 10																												
3	47.63	5 / 6.3 / 8 / 10																												
4	51.0	3.6 / 4 / 4.5 / 5 / 6.3 / 8 / 10 / 12																												
5	54.0	3.6 / 4 / 4.5 / 5 / 6.3 / 8 / 10 / 12																												
6	57.0	4 / 5 / 6.3 / 8 / 10																												
7	63.5	4.8 / 5.6 / 6.3 / 10 / 12.5																												
8	76.1	7.1 / 10 / 12.5																												

S. No.	BHEL SPECIFICATIONS	Bidder's OFFER																																				
2.3	TUBE MATERIAL:																																					
	a. Carbon Steel: SA192, SA210A1, SA210C b. Alloy Steel: SA209T1, SA213T11, SA213T22, SA213T91, T-23, T-93 c. Stainless Steel SA 213 TP304H, SA 213 TP321H, SA 213 TP347H																																					
2.4	Swaging Size:																																					
	<table border="1" data-bbox="423 619 1503 999"> <thead> <tr> <th>S.No</th> <th>Tube OD before Swaging (in mm)</th> <th>Tube OD after Swaging (in mm)</th> <th>Reduction in Tube OD (in mm)</th> </tr> </thead> <tbody> <tr><td>1</td><td>38.1</td><td>31.8</td><td>6.3</td></tr> <tr><td>2</td><td>44.5</td><td>38.1</td><td>6.4</td></tr> <tr><td>3</td><td>47.63</td><td>44.5</td><td>3.13</td></tr> <tr><td>4</td><td>51.0</td><td>47.63</td><td>3.37</td></tr> <tr><td>5</td><td>54.0</td><td>51.0</td><td>3.0</td></tr> <tr><td>6</td><td>57.0</td><td>54.0</td><td>3.0</td></tr> <tr><td>7</td><td>63.5</td><td>57.0</td><td>6.5</td></tr> <tr><td>8</td><td>76.1</td><td>63.5</td><td>12.6</td></tr> </tbody> </table>	S.No	Tube OD before Swaging (in mm)	Tube OD after Swaging (in mm)	Reduction in Tube OD (in mm)	1	38.1	31.8	6.3	2	44.5	38.1	6.4	3	47.63	44.5	3.13	4	51.0	47.63	3.37	5	54.0	51.0	3.0	6	57.0	54.0	3.0	7	63.5	57.0	6.5	8	76.1	63.5	12.6	
S.No	Tube OD before Swaging (in mm)	Tube OD after Swaging (in mm)	Reduction in Tube OD (in mm)																																			
1	38.1	31.8	6.3																																			
2	44.5	38.1	6.4																																			
3	47.63	44.5	3.13																																			
4	51.0	47.63	3.37																																			
5	54.0	51.0	3.0																																			
6	57.0	54.0	3.0																																			
7	63.5	57.0	6.5																																			
8	76.1	63.5	12.6																																			
2.5	Upsetting Sizes:																																					
	<table border="1" data-bbox="501 1094 1424 1321"> <thead> <tr> <th>S.No</th> <th>TUBE OD & Th before upsetting (in mm)</th> <th>TUBE OD & Th after upsetting (in mm)</th> <th>Material</th> </tr> </thead> <tbody> <tr><td>1</td><td>63.5 x 8</td><td>63.5 x 12.5</td><td>347 H</td></tr> <tr><td>2</td><td>51 x 7.1</td><td>51 x 11</td><td>T 91 / 347 H</td></tr> <tr><td>3</td><td>51 x 7.1</td><td>51 x 9</td><td>T 91 / 347 H</td></tr> </tbody> </table>	S.No	TUBE OD & Th before upsetting (in mm)	TUBE OD & Th after upsetting (in mm)	Material	1	63.5 x 8	63.5 x 12.5	347 H	2	51 x 7.1	51 x 11	T 91 / 347 H	3	51 x 7.1	51 x 9	T 91 / 347 H																					
S.No	TUBE OD & Th before upsetting (in mm)	TUBE OD & Th after upsetting (in mm)	Material																																			
1	63.5 x 8	63.5 x 12.5	347 H																																			
2	51 x 7.1	51 x 11	T 91 / 347 H																																			
3	51 x 7.1	51 x 9	T 91 / 347 H																																			

S. No.	BHEL SPECIFICATIONS		Bidder's OFFER
2.6	JOB DETAILS: Refer Annexure 1 & 2 (Typical Drawing)		
3.0	MACHINE CONFIGURATION		
3.1	Hydraulically operated Horizontal Tube Swaging and Upsetting machine – 1 No		
3.2	Hydraulic power pack unit – 1 No		
3.3	Electrical Control Panel – 1 No		
3.4	Operator Control Unit – 1 No		
4.0	QUALITY REQUIREMENTS FOR SWAGING & UPSETTING:		
4.1	Visual Defects: Outside and Inside surfaces shall be free from harmful surface defects when visually inspected, such as Scouring marks, Lines, Scratches, Tapering, Tool marks, Chatter marks, Tears, Drags and Depressions etc		
4.2	% Ovality = $\{(Max.OD - Min.OD) / Original OD\} \times 100$ at any particular cross-section of tube.	To be Less than 1% of Nominal OD.	
4.3	MPI / LPI	No significant indications	
4.4	Diameter tolerance on ID	+ 0.0 / -0.3 mm	
4.5	Axis Offset of small end to big end	0.15 mm	
5.0	OPERATING PARAMETERS:		
5.1	Tube Diameter	Minimum: 38.1 mm Maximum: 76.1 mm	
5.2	Tube Wall Thickness	3.2 mm to 12.5 mm	
5.3	Swaging length	400 mm (maximum)	
5.4	Stages of Swaging (Single stage or Multi stage)	Vendor to specify	
5.5	Included angle for Swaging (Refer Annexure - I)	15 degrees	
5.6	Reduction of Tube OD per stage for swaging	12.5mm	



S. No.	PARTICULARS	BHEL SPECIFICATIONS	Bidder's OFFER
5.7	Upsetting length	60 mm (maximum)	
5.8	Stages of Upsetting (Single stage or Multi stage)	Vendor to specify	
5.9	Merging of higher thickness at tube end to original thickness of tube (Refer Annexure - II)	Max. 35 deg	
5.10	Tube length handled	Minimum: 2000mm (Special Case – 950mm with supporting tube for extra length) Maximum: 15000mm	
5.11	Tube Clamping Length required	Vendor to specify	
5.12	Temperature for Hot Upsetting	1250 deg C (maximum)	
5.13	Swaging & Upsetting Direction	Along the Tube Axis (Horizontal)	
5.14	Tube batch quantity	100 tubes	
5.15	Reference tube size for establishing the machine capacity	<u>For Swaging</u> Tube OD from 57mm to 54mm <u>For Upsetting</u> Tube OD 51mm Thickness growth from 7.1 to 11mm	
6.0	PRODUCTIVITY		
6.1	No.of Swaging operation per shift in OD 57mm to 54mm Alloy Steel Tubes for batch production jobs.	150 Nos in one 8 hour shift	
6.2	No.of upsetting operation per shift in OD51x7.1 mm to OD 51x11mm Alloy Steel Tubes for batch production jobs.	100 Nos in one 8 hour shift	

S. No.	PARTICULARS	BHEL SPECIFICATIONS	Bidder's OFFER
7.0	MACHINE PARAMETERS		
7.1	Machine capacity in Tons	Vendor to specify	
7.2	Maximum Swaging Force in Tons	Vendor to specify	
7.3	Maximum Upsetting Force in Tons	Vendor to specify	
7.4	Maximum Upsetting Pressure	Vendor to specify	
7.5	Maximum Swaging Pressure	Vendor to specify	
7.6	Maximum Swaging Speed	Vendor to specify	
7.7	Maximum Upsetting Speed.	Vendor to specify	
7.8	Tube working Height (Tube axis)	1200 from ground level	
7.9	Maximum Operating Pressure	Vendor to specify	
7.10	Main Pump Motor capacity in kW	Vendor to specify	
7.11	Total Power Requirement in kVA	Vendor to specify	
8.0	MACHINE CONFIGURATION DETAILS:		
8.1	Machine shall be capable of performing both Swaging and Upsetting processes.		
8.2	The Swaging and Upsetting process of tube ends shall be in horizontal direction and in the axial direction of the tube.		
8.3	Vendor to submit General Arrangement drawing with the offer and explain the sequence of operation of Swaging and Upsetting Processes		
8.4	Vendor to explain the method of relieving the tube from the die after swaging or upsetting is completed.		
8.5	Stroke length of Swaging and Upsetting shall be adjustable		
8.6	Machine shall be designed to have rugged construction to withstand the forces applied during swaging and upsetting process.		
8.7	Dies changing shall be simple and easy. Sufficient clearance to be provided for assembling and dismantling of dies. Vendor to confirm.		
8.8	Sensing of tube end during retraction of tube after swaging for feed back to kick off stand (Kick off stand-BHEL Scope)		

S. No.	BHEL SPECIFICATIONS	Bidder's OFFER
8.9	Clamping die shall be in two halves - Vendor to provide details.	
8.10	Machine to be suitable for hot operation during upsetting	
8.11	Vendor to specify the type of lubrication of die during swaging (Whether manual or automatic) - Details to be furnished.	
8.12	SWAGING CYCLE (Preferred sequence) - Vendor to provide details of any other sequence, which will enhance the productivity.	
	a) Tube feeding by pinch roller (BHEL scope)	
	b) Sensing of tube positioning ready for swaging.	
	c) Clamping of tube	
	d) Swaging die movement for swaging operation	
	e) Clamping die open	
	f) Relieving the tube from the swaging die	
	g) Retraction by pinch roller	
8.13	UPSETTING CYCLE (Preferred sequence) - Vendor to provide details of any other sequence, which will enhance the productivity.	
	a) Tube heating to the required temperature (BHEL Scope)	
	b) Tube feeding by pinch roller (BHEL Scope)	
	c) Sensing of tube positioning for upsetting.	
	d) Clamping tube	
	e) Upsetting die / Mandrel movement for upsetting	
	f) Clamping die open	
	g) Relieving the tube from the upsetting die.	
	h) Retraction by pinch roller	
	i) Sensing of tube end before kick off from the tube stand	

S. No.	BHEL SPECIFICATIONS	Bidder's OFFER
8.14	OPTIONAL ITEM: Vendor to suggest a method of heating tube end before upsetting without significant drop in temperature while shifting the job from heating source to the machine.	
9.0	Hydraulics	
9.1	All Hydraulic valves to be of modular construction. All hydraulic operating components to be mounted on the manifold in a centralized place in convenient location for easy approach for Maintenance. Preferably away from the frame and on the side of the machine.	
9.2	Hydraulic power pack and Oil tank shall be separate from the Machine and positioned behind the machine conveniently to attend to any maintenance problems	
9.3	Vendor to specify the size of Hydraulic oil tank, capacity in litres	
9.4	First fill of Lubrication Oil & Grease shall be vendor's scope	
9.5	Hydraulic hose end fittings shall be welded nipple joints of suitable material	
9.6	Hydraulic circuits shall be designed with minimum number of control valves and to suit oil of ISO VG 46 or 68 only. Also minimum number of check-points to be provided wherever pressure is required to be read for setting and trouble shooting. Minimes Pressure Gauge - 1 No with Connecting Hose to be provided.	
9.7	Vendor to provide hydraulic Oil chiller unit - Refrigeration type for required tank capacity to maintain oil temperature not exceeding 40 deg C. – Vendor to provide details of Oil Chiller.	
9.8	All hydraulic tubelines to be neatly laid out.	
9.9	Lubricator, Regulator, Filter fitted with hand wheel valve shall be fitted at the centralized location for any pneumatic circuits	
10.0	Lubrication	
10.1	Centralized Automatic Lubrication system with a provision for adjusting the timer shall be provided for the machine.	

S. No.	BHEL SPECIFICATIONS		Bidder's OFFER
11.0	GENERAL DESIGN & CONSTRUCTIONAL FEATURES		
11.1	Foundation:		
11.1.1	Foundation of the machine shall be designed suitably, if any. Vendor to furnish details of the type of foundation required with force diagram. The machine shall be placed on anti-vibratory pads in case there is no foundation required.	Vendor to specify	
11.2	Controls:		
11.2.1	Type of controls provided	Vendor to specify	
11.2.2	Machine shall be operated in three modes viz., Manual, Semi-Automatic and Automatic Under Automatic option the complete Swaging / Upsetting cycle shall be automatic from tube feeding to tube kick off. Vendor to specify the feedbacks required from BHEL system of tube loading & feeding.	Vendor to specify	
11.2.3	Swaging / Upsetting Stroke Control.	Vendor to specify	
11.2.4	Tube feeding to the machine by pinch roller (BHEL Scope) Control to be provided on operator control panel	Vendor to confirm	
11.2.5	Tube Relieving from the Swaging / Upsetting Die	Vendor to specify	
11.3	Electrical Points:		
11.3.1	Wiring: All electrical motors, limit switches etc, on the machine shall be Wired using PVC sheathed cable running in conduits to cable ducts to common terminal block. External wiring from / to control panel, control desk, external motors etc shall be by means of screened multi-core cables.		
11.3.2	Encoders, limit switch, feed back devices shall be suitably placed for easier accessibility rigidly.		
11.3.3	All alarm tripping logics and control logics incorporated in the machine to be listed out by the vendor.		

S. No.	BHEL SPECIFICATIONS	Bidder's OFFER
11.3.4	Control circuit voltage should be 24 V DC.	
11.3.5	Control panel shall have built in 230V, 5 amps, 3 pin plug.	
11.3.6	Electrical control panel shall be adequately illuminated for maintenance purpose.	
11.3.7	Type of drives used for motors to be indicated.	
11.3.8	The machine shall be suitable for 415V with voltage fluctuation of +/-10%, 50Hz with frequency fluctuation of +/- 3%, 3 Phase, 3 wire system	
11.3.9	Electrics shall have IP 54 protection.	
11.4	Components used:	
11.4.1	All motors shall be from reputed makers like SIEMENS, ABB, Allen Bradley conforming to IEC Standards.	
11.4.2	All hydraulic elements shall be of VICKERS / REXROTH, DENISONS make.	
11.4.3	All hydraulic hoses shall be preferably of GATES make.	
11.4.4	All electrical items shall be of reputed make like SEW / ROCKWELL Allen Bradley/ Telemecanique / Delta	
11.4.5	All components/devices/terminals are to be incorporated with ferrules.	
12.0	GENERAL POINTS	
12.1	Make and Model of the machine to be mentioned. Detailed catalogs of the machine to be submitted with the offer.	
12.2	Complete description of all systems & sub-systems shall form part of the technical bid.	
12.3	A schematic diagram showing the layout of the machine & associated systems with salient dimensions shall be submitted along with the offer.	
12.4	The operating sequence of the machine with broad outline of various operations involved should be furnished with the offer.	

S. No.	BHEL SPECIFICATIONS	Bidder's OFFER
12.5	Standards for Design, Manufacture and testing of the machine shall be in accordance with internationally accepted standards.	
13.0	TOOLINGS	
13.1	List of tooling as follows: <ul style="list-style-type: none"> i. Clamping / Gripper Dies (2 piece construction) ii. Swaging Die iii. Straightening Die iv. Upsetting Die v. Upsetting Sleeve vi. Upsetting Mandrel etc for the sizes mentioned in specification and any optional tooling should be listed and quoted out item wise separately.	
14.0	AMBIENT CONDITIONS	
14.1	The Swaging and Upsetting machine with all Sub-Systems shall be suitable for operation in an ambient temperature varying from 25 to 50°C and with a relative humidity varying from 45% to 90% at the factory location.	
14.2	The entire equipment shall be Tropicalized in Design and Construction	
14.3	The offered equipment, Hydraulic system has to work in a normal fabrication shop environment in ambient conditions.	
15.0	SAFETY	
15.1	All safety features and safety interlocks provided in the machine shall be listed out by the vendor.	
15.2	Vendor to specify the safety features incorporated in the machine particularly during Hot Upsetting Process	

S. No.	BHEL SPECIFICATIONS	Bidder's OFFER
16.0	PAINTING:	
16.1	The heavier machine parts are to be heat-treated after fabrication (including castings and forgings) and shot blasted for surface preparation prior to painting.	
16.2	One coat of Primer with 25microns of DFT (Dry Film Thickness)	
16.3	Finish coat by Polyurethane Paint. Colour shade: RAL 6011 (Reseda Green)	
17.0	SPARES (to be recommended by the vendor)	
17.1	Item wise breakup of mechanical, hydraulic, electrical and electronic spares used on the machine in sufficient quantity as per recommendation of Vendor for 2 years of trouble free operation on three shifts continuous running basis shall be offered by vendor. The list to include following, in addition to BHEL recommended spares: (Unit Price of each item of spare should be offered)	
17.2	a) Mechanical & Hydraulic Spares: All types of Pumps, Valves, Pressure Switches, Transducers, Flow Switches, Filters, Seals, O-rings, Hydraulic Hoses etc.	
17.3	b) Electrical /Electronic: All types of Relays, Contactors, Proximity Switches, Push Buttons, Indicating Lamps, Semiconductor Fuses, Special Fuses, Circuit Breakers, Main Power Switch, Encoders, Power Module & Control cards etc.	
17.4	All types of spares for total machine and accessories should be available for at least ten years after supply of the machine. If machine or control is likely to become obsolete in this period, the vendor should inform BHEL sufficiently in advance and provide drawings of parts / details of spares & suppliers to enable BHEL to procure these in advance, if required	

S. No.	BHEL SPECIFICATIONS	Bidder's OFFER
18.0	DOCUMENTATION:	
18.1	Three sets (hard copies) of following documents, in English language should be supplied along with the machine:	
18.2	Operating manuals of Machine	
18.3	Detailed Maintenance manual of machine with all drawings of machine assemblies/sub-assemblies/parts including Electrical / Pneumatic/ Hydraulic circuit diagrams. All Assembly/ Sub Assembly Drawings shall be supplied with the part list.	
18.4	Machine data/ Commissioning data to be provided.	
18.5	Complete list of spares for machine and accessories, along with item part no / specification / type / model and name & address of the bought out item supplier shall be furnished along with documentation to be supplied with the machine	
18.6	Manufacturing drawings for all supplied toolings as mentioned under Clause 13.1	
18.7	Catalogues, O&M Manuals of all bought out items including drawings, wherever applicable.	
18.8	Detailed specification of all rubber items and hydraulic/lube fittings	
18.9	PLC program print-outs with comments in English, if PLC is used.	
18.10	PLC program and data on CD, if PLC is used	
18.11	Complete Master List of parts used in the machine shall be submitted by the vendor.	
18.12	Complete list of Alarms and Remedies to be provided by the vendor.	
18.13	One additional set of all the above documentation on CD.	
19.0	INSPECTION	
19.1	The Machine shall be offered for inspection and performance trials to test the design capabilities of the machine, by BHEL Engineers at Supplier's works before Dispatch.	

S. No.	BHEL SPECIFICATIONS	Bidder's OFFER
20.0	ACCEPTANCE CRITERIA	
20.1	All the features of the machines shall be operated and shown and to work as given in the specification, at supplier's works during inspection and during commissioning at BHEL works.	
20.2	The prove-out trials shall be for the Tube sizes given by BHEL during the technical discussions or at the time of releasing the Purchase Order. The tubes shall be supplied by BHEL for performing trials. The finished jobs have to pass all the quality tests as mentioned in the specification under Clause: 4.0	
20.3	The production output of the machine shall be proved out by the commissioning Engineer at BHEL works for the Production rate mentioned in the specification under Clause: 6.1 & 6.2	
20.4	Swaging & upsetting shall be proved out during commissioning at BHEL works for all the tube sizes for which Toolings have been ordered.	
21.0	ERECTION AND COMMISSIONING	
21.1	The supplier shall depute his engineer(s) for supervising the erection and commissioning of the machine at BHEL works and prove-out trials	
22.0	TRAINING	
22.1	The supplier shall train Four BHEL's Engineers in Operation and Maintenance (Mechanical, Electrical/ Electronics) of the Machine at supplier's works for a period not less than 5 working days. Vendor to quote on Manday basis.	
22.2	The supplier shall impart training to BHEL's Machine Operators and Maintenance crew in Operation and Maintenance (Mechanical, Electrical/ Electronics) after the commissioning of the Machine at BHEL works for not less than 5 working days. Vendor to quote on Manday basis.	

S. No.	BHEL SPECIFICATIONS	Bidder's OFFER
22.3	The training shall include the following: <ul style="list-style-type: none"> a. Safety b. Operation of the machine c. Trouble-Shooting, d. All special features of the machine e. Electrical / Mechanical / Electronics systems 	
22.4	Co-ordination for a visit of BHEL Personnel to an industry having similar / identical machine & system, in case of order realization, for system acquaintance & performance feedback	
23.0	GUARANTEE	
23.1	Equipment has to be guaranteed for its performance, for a minimum of 24 months from the date of commissioning.	

Enclosures:

- 1) Annexure- I SWAGING - Sketch
- 2) Annexure-II UPSETTING - Sketch

Sri S Ramakrishnan
DGM / M&S

Sri M Balasubramanian
DGM / BPN / TP

Sri S Kumarappan
SM / OP&C / TP

Sri G Subramanian
DM / Tool Engg

A.Venkateshwarlu
SM / Modernisation

SR**MB****SK****GS****AVL**

ANNEXURE - I

SWAGED TUBE END - SKETCH

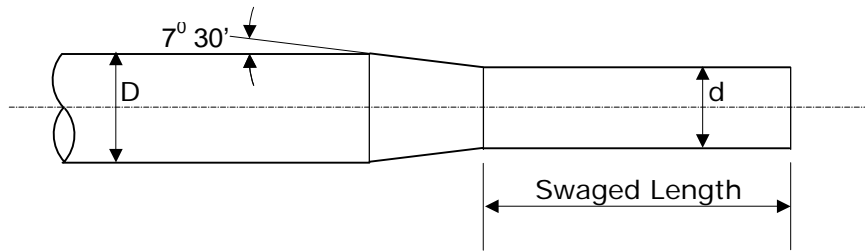

S.No	Tube OD before Swaging, 'D' (in mm)	Tube OD after Swaging, 'd' (in mm)	Reduction in Tube OD (in mm)
1	38.1	31.8	6.3
2	44.5	38.1	6.4
3	47.63	44.5	3.13
4	51.0	47.63	3.37
5	54.0	51.0	3.0
6	57.0	54.0	3.0
7	63.5	57.0	6.5
8	76.1	63.5	12.6

**Sketch No. CABS-2-15-01
BHEL, Tiruchirappalli**

ANNEXURE - II

UPSET TUBE END

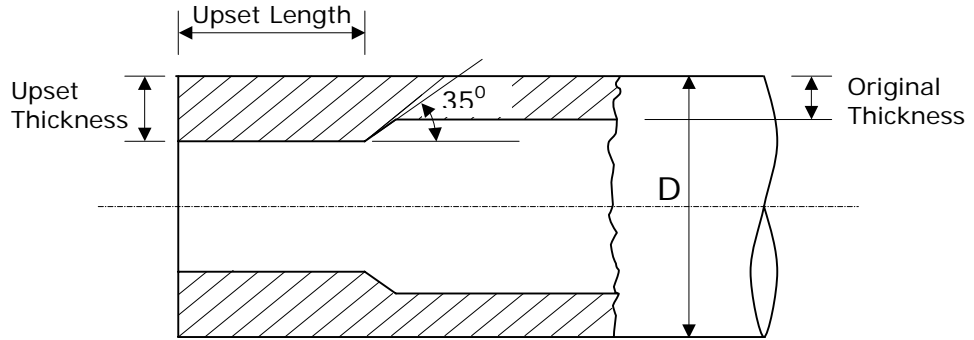

S.No	Tube OD 'D' (in mm)	Original Thickness (in mm)	Upset Thickness (in mm)
1	51.0	7.1	9
2	51.0	7.1	11
3	63.5	8.0	12.5

Sketch No. CABS-2-15-02
BHEL, Tiruchirappalli