



Bharat Heavy Electricals Limited

(High Pressure Boiler Plant)

Tiruchirappalli – 620014, TAMIL NADU, INDIA

CAPITAL PURCHASE / MATERIALS MANAGEMENT / MANUFACTURING

An ISO 9001
Company

ENQUIRY	Phone: +91 431 257 79 38 Fax : +91 431 252 07 19 Email : tvenkat@bheltry.co.in Web : www.bhel.com
----------------	---

	Enquiry Number:	Enquiry Date:	Due date for submission of quotation:
	2620700078	17.08.2007	29.09.2007

You are requested to quote the Enquiry number date and due date in all your correspondences. This is only a request for quotation and not an order.

Item	Description	Quantity	Delivery (Item required at BHEL on)
10	CNC Header Pipe Drilling Station as per the technical specification & commercial conditions applicable (to be downloaded from web site www.bhel.com or http://tenders.gov.in)	1 No.	30.11.2008

BHEL commercial terms & conditions with Price Bid and Bank Guarantee formats along with technical specifications can be downloaded from BHEL web site <http://www.bhel.com> or from the Government tender website <http://tenders.gov.in> (public sector units > Bharat Heavy Electricals Limited page) under Enquiry reference “2620700078”.

Tenders should reach us before 14:00 hours on the due date Tenders will be opened at 14:30 hours on the due date Tenders would be opened in presence of the tenderers who have submitted their offers and who may like to be present	Yours faithfully, For BHARAT HEAVY ELECTRICALS LIMITED Manager / Capital Purchase / MM / Manufacturing
--	--

PART A.**QUALIFYING CRITERIA FOR THE SUPPLY OF
CNC HEADER PIPE DRILLING STATION****SECTION – I : COMPANY PROFILE**

The BIDDER has to provide the details pertaining to each clause in the table given below to understand the profile of the BIDDER's COMPANY.

S.No.	PARTICULARS	VENDOR's RESPONSE
1.0	Number of Years of Experience of the BIDDER / VENDOR in the field of Design, Manufacture & Supply of CNC Machines for Machining/Drilling Applications or SPMs (Special Purpose Machines) for metal cutting works.	
2.0	Details on the Codes/Standards adopted for the Machine Design and Manufacture	
3.0	Details on Manufacturing Facilities available with the VENDOR for : a. Sourcing/Building Large Machine Castings or Fabricated Components b. Heat Treatment Facilities c. Heavy Machining & Grinding Facilities d. Machine Assembly & Testing Rigs	
4.0	Details of Quality System (with Stages of Internal Inspection) followed for the Machine Building and Testing of Capacity	

SECTION – II : QUALIFYING CRITERIA

The BIDDER / VENDOR has to meet the following requirements to get qualified for submitting an offer for the CNC Pipe Drilling Station :
[Additional Sheets shall be attached with the OFFER, to provide requisite details]

S.No.	REQUIREMENTS	VENDOR's RESPONSE
5.0	The BIDDER / VENDOR shall have a minimum of FIVE Years of Experience of in the Field of Design, Manufacture & Supply of Special Purpose or CNC Machines used for Drilling or other Machining Operations	
6.0	The BIDDER / VENDOR might have supplied atleast two numbers of the Machines (falling under the category of machines described under the Clause No. 5.0 and with Spindle Power more than 20 kW).	

S.No.	REQUIREMENTS	VENDOR's RESPONSE
7.0	Performance Certificate in the enclosed FORMAT for a period, not less than one year, from CUSTOMERS or Reference List of Customers with full contact details (E-mail id, Fax Number, Name of Contact Person), who are the End Users of the Machines (mentioned under Clause No. 5.0)	
8.0	BHEL reserves the right to verify the information provided by vendor. In case, it is found to be false/ incorrect, the offer shall get rejected.	
9.0	Details on SERVICE-AFTER-SALES Set-Up in India including the Addresses of Agents / Service Centres in India, to be furnished .	

SECTION – III : BID / OFFER FORMATS

The BIDDER / VENDOR has to note the following :

S.No.	REQUIREMENTS	VENDOR's COMPLIANCE
10.0	The BIDDER shall submit the offer in TWO PARTS - Technical [with PART A & PART B] & Commercial and Price Bid.	
11.0	The OFFER shall contain a comparative statement of Technical Specifications given by BHEL and the Offer Details submitted by the Bidder, against each Clause. A just 'YES' or 'CONFIRMED' or 'NO-DEVIATION' or 'COMPLIES' or 'ACCEPTED' or similar words in the technical comparative statement may lead to disqualification of the Technical Offer.	
12.0	The Technical Offer shall be supported by Product Catalogue (of similar machines supplied earlier) in ORIGINAL and complete technical details of 'Bought-Out-Items' proposed to be built into new machine.	
13.0	The Commercial Offer shall contain the Scope of Supply and the Un-Priced Part of the Price-Bid, for confirmation of the inclusion of all the accessories, tooling, auxiliary parts, spares, consumables, etc. with the main and basic equipment, to meet the technical specification requirements.	
14.0	Earlier performance/field experience (including service support) if any, with BHEL for the VENDOR's Equipment, will be a reckoning factor for the technical qualification of the OFFER.	

PERFORMANCE CERTIFICATE – [SAMPLE FORMAT]

(On Customer's Letter Head)

1. Supplier of the Equipment/Machine :

2. Make & Model of the Equipment :

3. Month & Year of Commissioning :

4. Application for which Machine is used :

5. a. Equipment Serial Number :
b. Spindle Motor Power in Horse Power/kW :
c. Brief Machine Specifications :

6. Performance of the Machine : Best in the market /
(with reasons for recommendation) Satisfactory /
Good /
Average /
Not Satisfactory

7. Any other Remarks :

Date:

Signature & Seal of the Authority
Issuing the Performance Certificate

PART B**TECHNICAL SPECIFICATIONS FOR
CNC PIPE DRILLING STATION****1.0 PURPOSE / APPLICATION :**

This enquiry is for a 5 axis CNC Gantry Type Drilling Machine (5 CNC Axes for the station are X,Y,Z, A & W) to run on the machine slide way, with an integrated indexing unit, shall be suitable for drilling holes radially in seamless steel pipes used in Headers for Higher Pressure Utility Boiler applications.

[ANNEXURE –1 gives the schematic diagram for the proposed drilling station.]

The scope of work also includes edge preparation operation of radially drilled holes on the pipe , for seating the nozzles on to the pipe, for welding. The pipes are to be held in an indexable chuck and intermediate job supports.

[ANNEXURE – 2 & 3 give the details on the drilling & edge preparation styles.]

The drilling head shall be suitable for use with "U" Drill / Indexable Drill / BW Drill / Delta Drill / Trepanning Tool & any latest version tools for this application.

2.0 JOB MATERIAL**Header Pipe**

[As per ASTM Standards]

Carbon Steels - SA 106 GrB & GrC

Alloy steels - SA 335 P11,P12&P22

SA 335 P91

Stainless Steels - SA312 TP304(L)

3.0 JOB SIZES

S.No.	PARTICULARS	SPECIFICATIONS	VENDOR'S COMPLIANCE
3.1	Outer Diameter Range	200 mm to 600 mm	
3.2	Length of Job / Pipe	9000 mm	
3.3	Pipe Wall Thickness Range	40 mm - 120 mm	
3.4	Size (diameter) of 'thru' hole	63 mm	
3.5	Trepanning Hole Size	120 mm	
3.6	Job Weight	5000 kgs. (maximum)	

4.0 TRAVERSES (With reference to the above job sizes)

S.No.	PARTICULARS	SPECIFICATIONS	VENDOR's OFFER
4.1	Gantry Movement : X-axis	Bidder to Specify [to accommodate the length of Job given above]	
4.2	Spindle Head-Stock Travel : Y-axis	500 mm	
4.3	Spindle Head Travel : Z-axis	Bidder to Specify [Note: BHEL Tool Length with Adopter is 250 mm]	
4.4	Size (diameter) of 'thru' hole	63 mm	
4.5	Trepanning Hole Size	120 mm	
4.6	Job Weight	5000 kgs. (maximum)	

5.0 AXES DRIVES (AC SERVO)

S.No.	PARTICULARS	SPECIFICATIONS	VENDOR's COMPLIANCE
5.1	Feed Rate (X,Y,Z,)	1 - 6000 mm/min	
5.2	Rapid Traverse (X,Y,Z)	Bidder to Specify (Industry Standard)	

6.0 SPINDLE HEAD STOCK

S.No.	PARTICULARS	SPECIFICATIONS	VENDOR's OFFER
6.1	Main Spindle Motor	AC Variable Speed	
6.2	Power - Continuous Duty	Bidder to Specify (Not to be less than 30 kW)	[Power calculation details to be submitted by the BIDDER]
6.3	Spindle Speed	0 - 1500 rpm (steplessly variable)	[Bidder to provide details on availability of higher speed options]
6.4	Spindle Nose Taper	BT 50	

7.0 ACCURACY

S.No.	PARTICULARS	SPECIFICATIONS	VENDOR's OFFER
7.1	Positioning Accuracy	± 0.015 mm (over 1000 mm length in X, Y and Z axes)	
7.2	Repeatability	± 0.010 mm (X, Y and Z axes)	
7.3	Resolution on "A" axis	± 0.1 deg.	

8.0 MACHINE BED

S.No.	PARTICULARS	SPECIFICATIONS	VENDOR's OFFER
8.1	No. Of Guide ways	Bidder to Furnish Details	
8.2	Width of Bed across Guide-Ways	Bidder to Furnish Details	
8.3	Type of Guide-Ways	Bidder to Furnish Details	(Details should be given with the offer)
8.4	Hardness of Guide - Ways	Bidder to Furnish Details	

9.0 CNC INDEXING HEAD : (A – axis)

- 9.1 Hydraulically operated 3 - jaw self-centering chuck (OD clamping).
- 9.2 Indexing of the job 'thro' AC Servo Feed Drive
- 9.3 Indexing Head to be located at one end of the machine guide ways.
- 9.4 Rotary Speed for Indexing Head : 0 to 4 rpm (steplessly variable)

10.0 BASIC DESIGN & CONSTRUCTIONAL FEATURES

S.No.	DESCRIPTION / PARTICULARS	VENDOR's OFFER [with Technical Details]
10.1	The machine shall have Moving type of Gantry structure, on which the machine spindle head is to be mounted.	
10.2	The Gantry shall be provided with the longitudinal traverse (X-Axis) on slide- ways built up by adding suitable number of machine beds, to form the required total traverse.	
10.3	Automatic hydraulic plunger clamps shall be provided to clamp the Gantry to the bed after each positioning along X axis before commencement of drilling, in addition to the Servo Lock system .	
10.4	Walk on type telescopic cover (made of stainless steel) fitted with wipers, shall be provided to protect the machine guide ways. Joints of telescopic covers should be so sealed to avoid ingress of dust.	
10.5	Operator Platform along with the Operator Panel shall be integral with the Moving Gantry, as a single unit.	
10.6	Sliding type of Chip Guard shall be provided on the Gantry suitably, to avoid metal chips falling on to the Operator Platform.	
10.7	The Hydraulic Power-pack with Oil Tank for the machine head shall be provided on the Moving Gantry.	

S.No.	DESCRIPTION / PARTICULARS	VENDOR's OFFER [with Technical Details]
10.8	Independent type Chip Conveyor of suitable width shall be provided to collect and deliver the metal chips at one end of the machine bed efficiently.	
10.9	Coolant Tank of suitable volume shall be provided and is to be equipped with a pump of capacity to deliver 75 LPM at 15 bar pressure, at delivery end of pump, to facilitate "pressure coolant thro' spindle" system . Additionally, flood coolant arrangement at the tool tip, also has to be provided with separate pump.	
10.10	Clamping by "W" axis shall be provided in the Gantry to clamp the job and also to ensure better rigidity to the Gantry, during the drilling operation. The "W" Axis has to do clamping as well as give the reference for the spindle stroke.	
10.11	Spindle Head shall be integral with Gantry and shall be powered in vertical "Z"- axis and horizontal "Y"- axis. The axis clamping for the spindle head shall be through hydraulic means.	
10.12	Guards shall be provided around the spindle to guide the chips to fall onto the Chip Conveyor.	
10.13	The Indexing Head shall be of rigid and independent construction, suitably installed and aligned with the machine bed, at one end.	
10.14	Job clamping shall be automatic by the Indexing Head through the three-jaw chuck, operated hydraulically.	
10.15	Steady Rest for job supporting shall be provided with motorized movement for the 'up and down' and the traverse along "X" –axis. In addition, a manual operation for horizontal traverse of 100 mm for the job-supporting roller assembly to be provided.	[Stroke to be specified by the Bidder, to suit the job dimensions].
10.16	All gears are to be hardened and ground	
10.17	Operator's panel having complete CNC and machine control system with CRT of required configuration shall be provided for convenient and efficient operation. All switches should be within reach of operator. All displays/indications should also be conveniently placed .	(Layout showing complete details should be submitted with the offer)
10.18	Vendor to furnish details of material, hardness & constructional details including explanatory drawings of various components/assemblies like Spindle head, Gantry, Tool Holder Slide, Machine Bed, indexing head, Feed Transmission System, Feedback System etc. of the machine.	
10.19	Video images on CD / Hard copy of literature with photographs & drawings explaining the technical features should be enclosed with the offer	

11.0 FEED DRIVE SYSTEM

S.No.	DESCRIPTION / PARTICULARS	VENDOR's OFFER [with Technical Details]
11.1	Feed drives/ motors for X,Y, Z & A axes [AC Servo motors] shall be digital type of either Siemens or Fanuc or any other reputed make	(Details of model, make, type etc. to be furnished in the offer)
11.2	Maximum feed force for all axes	
11.3	Feed back system for X,Y,,Z & A axes : Siemens / Fanuc / Heidenhain Rotary Encoders. For "W" axis Linear Encoder	
11.4	Feed back system for Spindle Rpm: Siemens / Fanuc / Heidenhain Rotary Encoders	
11.5	Type of power transmission: Pre-loaded backlash-free re-circulating ball screw drive for Y and Z axis. For other axes details to be furnished.	(Complete description including dia. of Ball Screw for each axis)

12.0 CNC SYSTEM & FEATURES

S.No.	DESCRIPTION / PARTICULARS	VENDOR's OFFER [with Technical Details]
12.1	Make: Fanuc / Siemens.	
12.2	Type: PC based - Latest version	
12.3	Model (suitable and latest version, as available at the time of ordering, should be supplied).	
12.4	Details of Standard Features of the OFFERED CNC System, suiting to the drilling operations mentioned	
12.5	Details of Optional Features, recommended by Vendor for this configuration of the Drilling Station.	
12.6	The system shall have full alphanumeric keyboard, TFT colour display (10.4" or more), additional draw-out type Qwerty Key Board and mouse in suitable enclosure, RS232C serial interfaces, parallel interface for printer, COM port for tele-diagnostics, electronic hand wheels for all axes (MPG – Manual Pulse Generator), compact disc drive unit for data input/output, hard disk of sufficient capacity (Largest size available at the time of order shall be supplied), graphic simulation and preinstalled system software & other required soft wares etc .	(Details should be furnished by the Vendor in the offer)
12.7	Hand Held Unit : Type B-MPI of Siemens make or equivalent along with sufficient length of interfacing cable which can be taken near to the spindle head for job setting and similar other purposes.	(Details should be furnished by the Vendor in the offer)

13.0 DIAGNOSTIC SYSTEM

S.No.	DESCRIPTION / PARTICULARS	VENDOR's OFFER [with Technical Details]
13.1	TELE-DIAGNOSTIC SERVICE : Tele-diagnostic service should be provided through International telephone lines along with required Hardware / Software package for the supplied CNC system for remote diagnosis and correction of the problems in both CNC System and PLC of the machine. This should be provided free of charge for the guarantee period. The Vendor should inform terms and conditions for the service after guarantee period. Subsequently, it should be possible to use other platforms, such as Internet or ISDN, subject to their availability in future. BHEL will provide the necessary telephone line near the machine.	
13.2	FAULT DIAGNOSTIC SYSTEM : Vendor's own diagnostic system with required hardware and software should be supplied and installed on the CNC system. This should include customized auto-diagnostic system with supporting hardware and software, which shows detailed cause, and remedy for the fault on the display for faults related to mechanical and electrical maintenance.	
13.3	Help guide should be provided to use both diagnostic systems	

14.0 MACHINE LIGHTING SYSTEM

S.No.	DESCRIPTION / PARTICULARS	VENDOR's OFFER [with Technical Details]
14.1	A fluorescent machine lamp with drip proof protective cover to be provided for the drilling area visibility.	
14.2	A spot light with sufficiently long cable should also be provided 24V AC.	
14.3	All light fittings, consumables, adapters/receptacles should have compatibility with Indian equivalents	
14.4	Flashing / Rotary type machine lamp to denote End of Cutting, Program Stop, Alarm/Tripping Condition, etc. as per Industry Standards.	

15.0 SERVO VOLTAGE STABILIZER

S.No.	DESCRIPTION / PARTICULARS	VENDOR's OFFER [with Technical Details]
15.1	Indian make Oil / Air Cooled servo Controlled Voltage Stabilizer suitable for complete machine, its drives, controls, PLC etc. with no undesirable Harmonics in the stabilizer output.	
15.2	Make. : NEEL / DELTA / AEI / POWER AID	
15.3	Model & Rating (Suitable for the machine load. Bidder to specify the noise level also)	
15.4	Spares Package for the Voltage Stabilizer for 2 years working also shall be offered.	
15.5	Catalogue of the Voltage Stabilizer shall be submitted with the offer.	

16.0 ULTRA ISOLATION TRANSFORMER

S.No.	DESCRIPTION / PARTICULARS	VENDOR's OFFER [with Technical Details]
16.1	Indian make Ultra Isolation Transformer suitable for complete machine, its drives, controls, PLC etc. shall be supplied	
16.2	Make NEEL / DELTA / AEI / POWER AID	
16.3	Model and Rating to be suitable for the Drilling Station	
16.4	Spares Package for the Ultra Isolation Transformer for 2 years working shall also be offered.	
16.5	Catalogue of the Ultra Isolation Transformer shall be submitted with the offer.	

17.0 IMPORTANT POINTS

S.No.	DESCRIPTION / PARTICULARS	VENDOR's OFFER [with Technical Details]
17.1	415V + 10% / -10%, 50HZ +/-1.5 HZ, 3 Phase AC (3 wire system with out neutral) Power Supply Source will be provided by BHEL at a single point near the machine, as per layout recommended by Vendor. All types of cables, connections, circuit breakers etc. required for connecting BHEL's power supply point to different parts of the machine/control cabinets, shall be the responsibility of vendor.	
17.2	All electrical equipment shall be Tropicalized and shall have IP 54 degree of protection	
17.3	All electrical control cabinets & panels should be dust and vermin proof	

S.No.	DESCRIPTION / PARTICULARS	VENDOR'S OFFER [with Technical Details]
17.4	All electrical components in the cabinets should be mounted on DIN Rail	
17.5	All electrical panels should be provided with CFL lamps for sufficient illumination and electric power receptacles of 220 Volts, 5/15 Amp. AC. All adapters/receptacles should have compatibility with Indian equivalents.	
17.6	Motors shall be from M/s Siemens / ABB or other reputed make conforming to IEC Standards and acceptable to BHEL	
17.7	All electrics shall be of reputed make like Siemens, L&T, BCH, Tele-mechanique.	
17.8	Electrical drives shall be of Siemens / ABB / L&T / Eurotherm and PLC of SEW / Allen Bradley / Siemens / Messung	
17.9	All components / devices / terminals are to be incorporated with ferrules.	
17.10	All cables/ hoses moving with traversing axes should be installed in cable drag chain. Additionally, all the cable trays required for laying of cables should be included in the offer.	
17.11	Vendor should ensure the proper earthing for the machine and its accessories.	
17.12	AIR CONDITIONERS : Air Conditioners with Dehumidifiers of suitable / sufficient capacity to be provided for all Electrical / Electronic Panels / Cabinets including Operator's Panel considering specified ambient conditions. Detailed specifications of the same are to be submitted.	
17.13	Independent Centralized Automatic Lubricating System for all sliding area in the gantry and bed to be provided with metallic tubings.	
17.14	All hydraulic elements used shall be of Vickers/Rexroth or any other reputed make acceptable to BHEL.	
17.15	All hydraulic operating components to be mounted on the manifold in a centralised place on the hydraulic power pack .	
17.16	Hydraulic circuits shall be designed with minimum number of control valves and to suit oil of ISO VG 46 or 68 only. Also MINIMESS checkpoints to be provided wherever pressure is required to be read for setting and troubleshooting.	
17.17	All Hydraulic hoses shall be preferably from GATES, MARKWELL, Parker Hannifin only,	
17.18	The control voltage for all solenoid operated valves should be less than 110 V	
17.19	Hydraulic Pump Capacity (flow / pressure) to be specified	

S.No.	DESCRIPTION / PARTICULARS	VENDOR'S OFFER [with Technical Details]
17.20	Filtration System, Failure indication Automatic shut off provision Details should be submitted.	
17.21	Each pump should have an independent motor. Tandem pumps should not be used	
17.22	Refrigerant type Cooling system of sufficient capacity to maintain complete Hydraulic System, including lubrication oil, hydrostatic oil and gearbox oil, etc. at a temperature not exceeding 50 deg C irrespective of the ambient conditions. Complete details should be submitted	
17.23	First filling of all required Oils & Grease etc. should be supplied by vendor. Indigenous (Indian) source or Indian equivalent and specifications of oils/ greases are also to be provided by the vendor.	
17.24	GUARANTEE : The equipment has to be guaranteed for its performance and also of the sub-assemblies / bought-out items, for a minimum period of 24 months from the date of commissioning at BHEL Works.	

18.0 ENVIRONMENTAL PERFORMANCE OF THE MACHINE

S.No.	DESCRIPTION / PARTICULARS	VENDOR'S COMPLIANCE]
18.1	Maximum noise level shall be 85 dB (A) at normal load condition, 1 M away from the machine with correction factor for back ground noise, if necessary. This will be measured as per international standards like DIN 45635-16. Vendor to demonstrate compliance to noise level, if so required.	
18.2	The machine shall be suitable for an ambient temperature of +45 ° C and relative humidity of 95 % respectively, but both do not occur simultaneously.	
18.3	If any safety / environmental protection enclosure is required it shall be built in the machine by the vendor.	
18.4	Paint of the machine should be oil / coolant resistant and should not peel off and mix up with coolant.	
18.5	Weather conditions are tropical, Atmosphere may be dust laden during some part of the year. Machine shall be kept in the normal shop floor condition.	
18.6	Thermal Stability of the complete machine keeping in view specified Ambient Conditions and accuracy requirements of BHEL components and vendor should ensure trouble free operation of the machine.	
18.7	The total machine, including attachments and accessories, shall be suitable for 24 hrs. continuous operation to its full capacity for 24 hour a day and 7 days a week throughout.	

19.0 SAFETY ARRANGEMENTS

[the following safety features, in addition to other standard safety features, shall be provided]

S.No.	DESCRIPTION / PARTICULARS	VENDOR's OFFER [with Technical Details]
19.1	Machine should have adequate and reliable safety interlocks / devices to avoid damage to the machine, work piece and the operator due to mistakes or the malfunctioning. Machine functions shall be monitored continuously and alarm / warning indications through lights/ alarm number with messages (on CNC display and panels) should be available.	
19.2	The spindle rotation should start only after proper clamping of job.	
19.3	All relevant axes should be included in the interlock to ensure vibration free drilling operation.	
19.4	Coolant pump and Chip conveyer should start during drilling operation only.	
19.5	A detailed list of all alarms / indications provided on machine should be submitted by the Vendor.	
19.6	All the pipes, cables etc. on the machine should be well supported and protected. These should not create any hindrance to machine operator's movement for effective use of machine.	
19.7	All the rotating parts used on machine should be statically & dynamically balanced to avoid undue vibrations and suitably guarded.	
19.8	Emergency Switches at suitable locations as per International Norms should be provided.	
19.9	All lubricated parts like Bed, guide ways shall have provision for collecting the used Lubrication oil from machine guide ways and preventing them from spilling over on to the ground.	

20.0 TOOLING FOR JOB PROVE-OUT

S.No.	DESCRIPTION / PARTICULARS	VENDOR's OFFER [with Technical Details]
20.1	Tooling System shall consist of a base tool holder fitted with Standard ISO indexable carbide inserts, capable of generating all edge preparation styles as indicated in ANNEXURE-2 & 3, in addition to the through drilling in header pipes. Cutting Parameters Envisaged : a. Cutting Speed : 100 -150 m / min. b. Depth of Cut : 5 -18 mm. c. Cutting Feed : 0.2 - 0.6 mm / rev. [Bidder to recommend better metal cutting parameters , for higher productivity] :	

S.No.	DESCRIPTION / PARTICULARS	VENDOR's OFFER [with Technical Details]
20.2	Limitation regarding length and weight of tool or tool holder clamped in different operating conditions to be elaborated, for trouble free operation	
20.3	5 Sets of Cutting Tools, 2 Nos. of Tool Holders, with sufficient quantity of adapters, etc. as recommended by the Bidder, for complete machining of prove out components (at BHEL works) shall be offered.	

21.0 MACHINE SPARES

S.No.	DESCRIPTION / PARTICULARS	VENDOR's OFFER [with Technical Details]
21.1	Itemised break-up of mechanical, hydraulic, electrical spares used on the machine in sufficient quantity as per recommendation of Vendor for 2 years of trouble free operation on three shifts continuous running basis should be offered by vendor. The list to include following, in addition to other recommended spares: (Unit Price of each item of spare shall be offered)	
21.2	Mechanical & Hydraulic Spares: Bearings, clutches, gears and all types of pumps, Valves, pressure switches / transducers, filters, seals, O rings, Hydraulic Hoses, etc.	
21.3	Electrical: All types of Relays, Contactors, Proximity Switches, Push Buttons, Indicating Lamps, Semiconductor Fuses, Special Fuses, Circuit Breakers, Main Power Switch.	
21.4	All types of spares for total machine and accessories should be available for at least ten years after supply of the machine. If machine or control is likely to become obsolete in this period, the vendor should inform BHEL sufficiently in advance and provide drawings of parts / details of spares & Vendors to enable BHEL to procure these in advance, if required.	
21.5	Vendor to confirm that complete list of spares for machine and accessories, along with specification / type / model, and name & address of the spare Vendor shall be furnished along with documentation to be supplied with the machine.	

22.0 DOCUMENTATION

S.No.	DESCRIPTION / PARTICULARS	VENDOR's OFFER [with Technical Details]
22.1	THREE sets of following documents (Hard Copies) in English language shall be supplied along with machine	
22.2	Operating Manuals of Machine & CNC system	
22.3	Programming Manuals of Machine & CNC system	
22.4	Detailed Maintenance Manual of machine with all drawings of machine assemblies/sub-assemblies/parts including Electrical / Pneumatic/ Coolant / Hydraulic circuit diagrams. All Assembly/ Sub Assembly Drawings shall be supplied with the part list also	
22.5	Maintenance, Interface & Commissioning Manuals for CNC system, spindle & feed drives.	
22.6	Manufacturing drawings for all supplied tool holders, coolant connections, adapters, sleeves, fixtures etc.	
22.7	Component drawings for all wearing parts to be provided.	
22.8	Catalogues, O&M Manuals of all bought-out-items including drawings, wherever applicable.	
22.9	Detailed specification of all rubber items and hydraulic/lube fittings	
22.10	Hydraulic, Coolant, Lubrication and Electrical circuits with Bill Of Materials	
22.11	Operating Manuals, Maintenance Manuals and Catalogues shall be supplied for Voltage Stabilizer, Air-Conditioners, Air-Compressor (if any), Isolation Transformer and all other Accessories supplied.	
22.12	PLC program print-outs with comments in English.	
22.13	PLC program on CD, NC data & PLC data on floppy.	
22.14	Complete back-up of hard disk on GHOST CD and clear written Instructions (3 copies) to take back-up and reloading of a new hard disk.	
22.15	Complete Master List of parts used in the machine shall be submitted by the vendor.	
22.16	One additional set of all the above documentation on CD ROM, wherever possible.	

23.0 TRAINING OF BHEL PERSONNEL

S.No.	DESCRIPTION / PARTICULARS	VENDOR's OFFER [with Technical Details]
23.1	Air-fare, boarding & lodging for the trainees shall be borne by BHEL.	
23.2	Competent, English speaking experts shall be arranged by the vendor during training for satisfactory & effective training of BHEL personnel.	

S.No.	DESCRIPTION / PARTICULARS	VENDOR's OFFER [with Technical Details]
23.3	BHEL Personnel shall be trained at Supplier's Works for mutually agreed period in the area of a. CNC Part Programming / Technology, Use of all CNC Features, Programming for Systems of Supplied Accessories (if any) etc. b. Electrical, Electronic & CNC Maintenance for Machine & other supplied equipments c. Mechanical & Hydraulic Maintenance of the Machine & other supplied equipments d. Operation of the Machine & other supplied equipments.	
23.4	Bidder to quote for training on man / week basis	
23.5	Bidder should commit to organize training of Electronics Engineer and Programmer at the CNC System Manufacturer's works for advanced features and specialised training, if so required by BHEL	

24.0 INSPECTION & MACHINE ACCEPTANCE

S.No.	DESCRIPTION / PARTICULARS	VENDOR's OFFER [with Technical Details]
24.1	MACHINE ACCEPTANCE: (Tests/Activities to be performed by Vendor at Vendor's works, on the machine, before dispatch:)	
24.1.1	Geometrical accuracies as per applicable standard test chart recommended by the Vendor	
24.1.2	Full load test to demonstrate the maximum power & cutting capacity of the machine.	
24.1.3	Demonstration of all features of the machine, control system & accessories	
24.2	Tests / Activities to be carried out at BHEL works while commissioning the machine:	
24.2.1	Geometrical accuracies as per. Applicable standard test chart recommended by the Vendor	
24.2.2	Positioning accuracies as per VDI 3441.	
24.2.3	Full load test to demonstrate the maximum power & cutting capacity of the machine.	
24.2.4	Demonstration of all features of the machine, control system & accessories to the satisfaction of BHEL for efficient and effective use of the machine	
24.2.5	Demonstration by actual use of all supplied attachments and accessories to their full capacity.	
24.2.6	Machining of test pieces to perform the drilling and edge preparation profiles.	

S.No.	DESCRIPTION / PARTICULARS	VENDOR's OFFER [with Technical Details]
24.2.7	The details of prove-out trials shall be based on the mutually agreed job pattern arrived at, during the technical discussions, to be held at BHEL Works after the tender opening.	
24.2.8	Supervision by vendors of independent operation of machine by BHEL after job prove out during the training period of 8 working days	
24.3	ACCURACY TESTS : GEOMETRICAL ACCURACY	
24.3.1	Geometrical Accuracy Tests shall be in accordance with applicable standard (VDI Standard No.3441) recommended by the Vendor. Detailed Test Charts for the same, clearly showing the accuracies to be achieved on the machine, shall be submitted with the offer.	
24.3.2	All other accuracies shall confirm to Vendors Test chart.	
24.3.3	All the above accuracies should be demonstrated to BHEL engineers during pre-acceptance at Vendors works and during Erection & Commissioning at BHEL Works.	

25.0 MACHINE FOUNDATION

S.No.	DESCRIPTION / PARTICULARS	VENDOR's COMPLIANCE
25.1	Vendor shall submit the preliminary layout drawing for getting BHEL's approval within one month from the date of Letter of Intent (LOI). Vendor shall submit complete foundation details including static and dynamic loads within three months after getting BHEL's approval. The layout should consist of all requirements pertaining to complete machine including space requirement for Voltage Stabilizer, Isolation Transformer, & any other accessories. BHEL shall construct complete foundation for the machine as per the Vendor's recommendation.	
25.2	Vendor should arrange equipments required for the testing of foundation, if required by the Vendor. The Vendor shall also indicate detailed specifications of grouting compound and Grouting procedure etc. for foundation bolts of the machine	

26.0 MACHINE ERECTION & COMMISSIONING

S.No.	DESCRIPTION / PARTICULARS	VENDOR'S COMPLIANCE
26.1	Vendor shall submit the preliminary layout drawing for getting BHEL's approval within one month from the date of Letter of Intent (LOI). Vendor shall submit complete foundation details including static and dynamic loads within three months after getting BHEL's approval. The layout should consist of all requirements pertaining to complete machine including space requirement for Voltage Stabilizer, Isolation Transformer, & any other accessories. BHEL shall construct complete foundation for the machine as per the Vendor's recommendation.	
26.2	Vendor to take full responsibility for supervision of the erection, vendor shall start up, test the machine, it's control & all types of other supplied equipment, carrying out machining of test pieces etc. Service requirement like power, air & water shall be provided by BHEL at only one point to be indicated by Vendor in their foundation/layout drawings. Other requirements like crane and helping personnel shall also be provided by BHEL.	
26.3	Erection & Commissioning of Voltage stabilizer, Isolation Transformer & Air Compressor shall also be responsibility of the Vendor.	
26.4	Successful proving of BHEL components by the Vendor shall be considered as part of commissioning. All tests, as mentioned in (Clause 24.0) shall form part of the commissioning activity.	
26.5	Tools, Tackles, Test Mandrels, instruments and other necessary equipment including Laser equipment required to carry out all above activities should be brought by the Vendor.	
26.6	Commissioning spares, required for commissioning of the machine within stipulated time, shall be brought by the Vendor on returnable basis.	
26.7	Portion, if any, of the machine, accessories and other supplied items where paint has rubbed off or peeled during transit or erection should be repainted and merged with the original surrounding paint by the vendor. For this purpose, the Vendor should supply sufficient quantity of touch-up paint of various colours of paint used.	
26.8	Schedule of Erection and Commissioning shall be submitted with the offer.	
26.9	Charges, duration, terms & conditions for Erection & Commissioning should be furnished in detail separately by Vendor along with the Technical Offer.	

S.No.	DESCRIPTION / PARTICULARS	VENDOR'S COMPLIANCE
26.10	LEVELLING & ANCHORING SYSTEM : Complete anchoring system including foundation bolts, anchoring materials, fixtures, levelling shoes etc shall be supplied along with the Machine.	
26.11	TOOLS for ERECTION, OPERATION & MAINTENANCE : The vendor shall bring special tools and equipment required for erection of the machine. Necessary tools like Torque Wrench, Spanners, Keys, Grease Guns etc. for Operation & Maintenance of the machine should be supplied. List of such tools shall be submitted with offer.	

27.0 MACHINE PACKING

S.No.	DESCRIPTION / PARTICULARS	VENDOR'S COMPLIANCE
27.1	Sea worthy & rigid packing for all items of complete machine, CNC System, all accessories and other supplied items to avoid any damage/loss in transit. When machine is dispatched in containers, all small loose items shall be suitably packed in boxes	

28.0 MACHINE DATA [GENERAL] – DESIRED TO BE INDICATED WITH THE OFFER

S.No.	DESCRIPTION / PARTICULARS	VENDOR'S RESPONSE
28.1	Machine Model Number	
28.2	Total Connected Electrical Load in kVA	
28.3	Floor area required (Length, Width, Height) for Complete Machine & Accessories	
28.4	Machine lubrication	
28.5	Painting of Machine / Electrical Panels	
28.6	Total weight of the Machine	
28.7	Weight of heaviest part of Machine	
28.8	Weight of the heaviest assembly / sub-assembly of the Machine	
28.9	Dimensions of largest part/ sub-assembly/ assembly of the Machine	

Enclosures :

- Annexure - 1** : **Schematic Sketch for Machine Configuration**
Annexure - 2 & 3 : **Drilling & Edge Preparation Styles & Details**

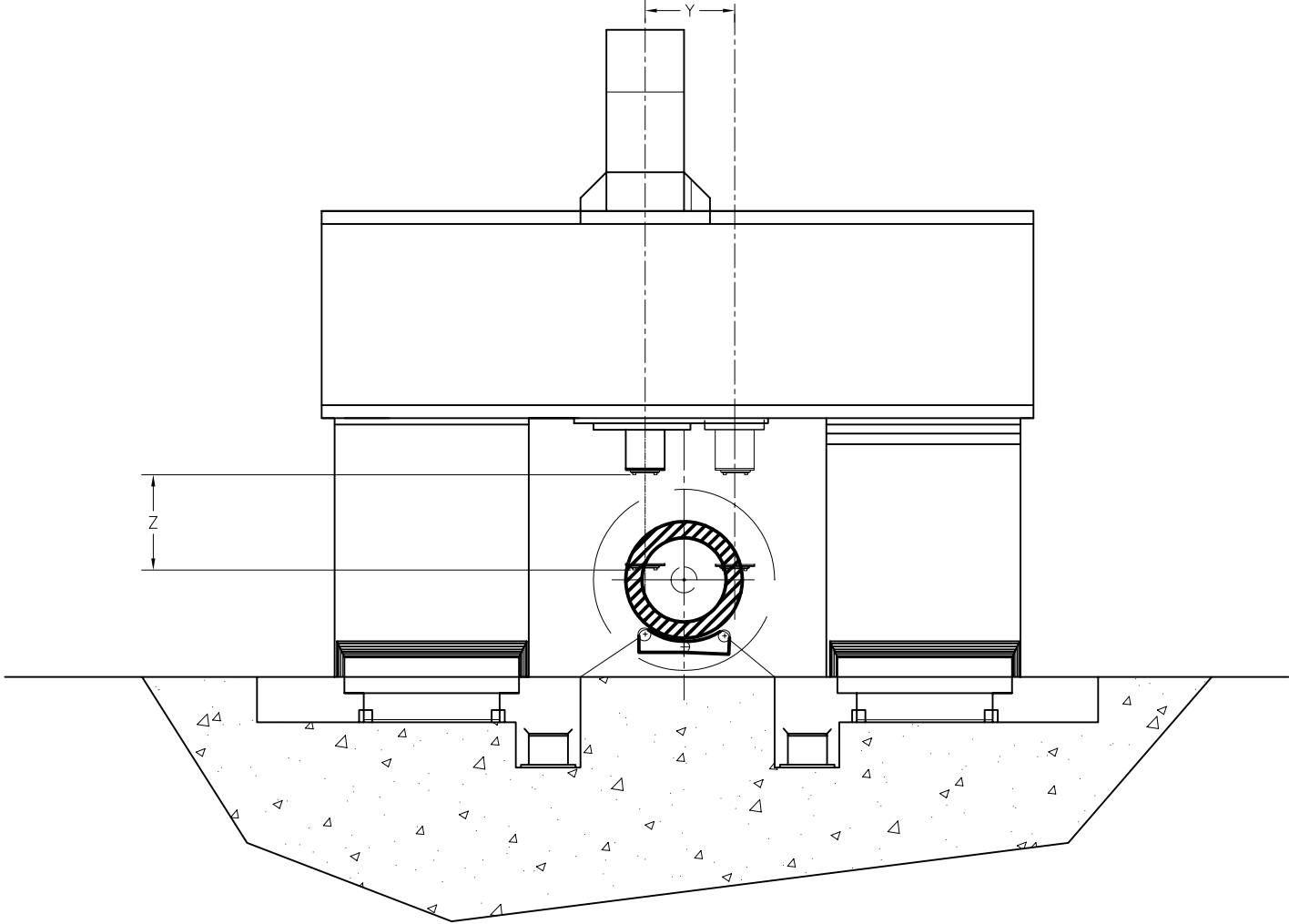

SCHEMATIC SKETCH FOR A CNC
PIPE DRILLING MACHINE

HEADER PIPE DRILLING EDGE PREPARATION DETAIL

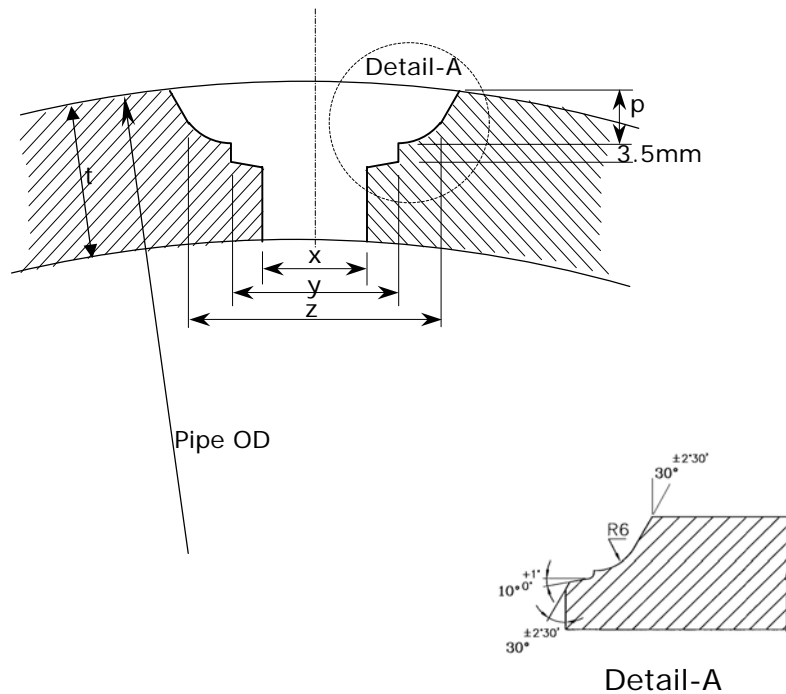

All dimensions are in 'mm'

Dimension	EP Style 1	EP Style 2	EP Style 3
x	21	30	127
y	35	45.5	143.5
z	55	64.5	162.5
p	10	10	21
t	40	50	80

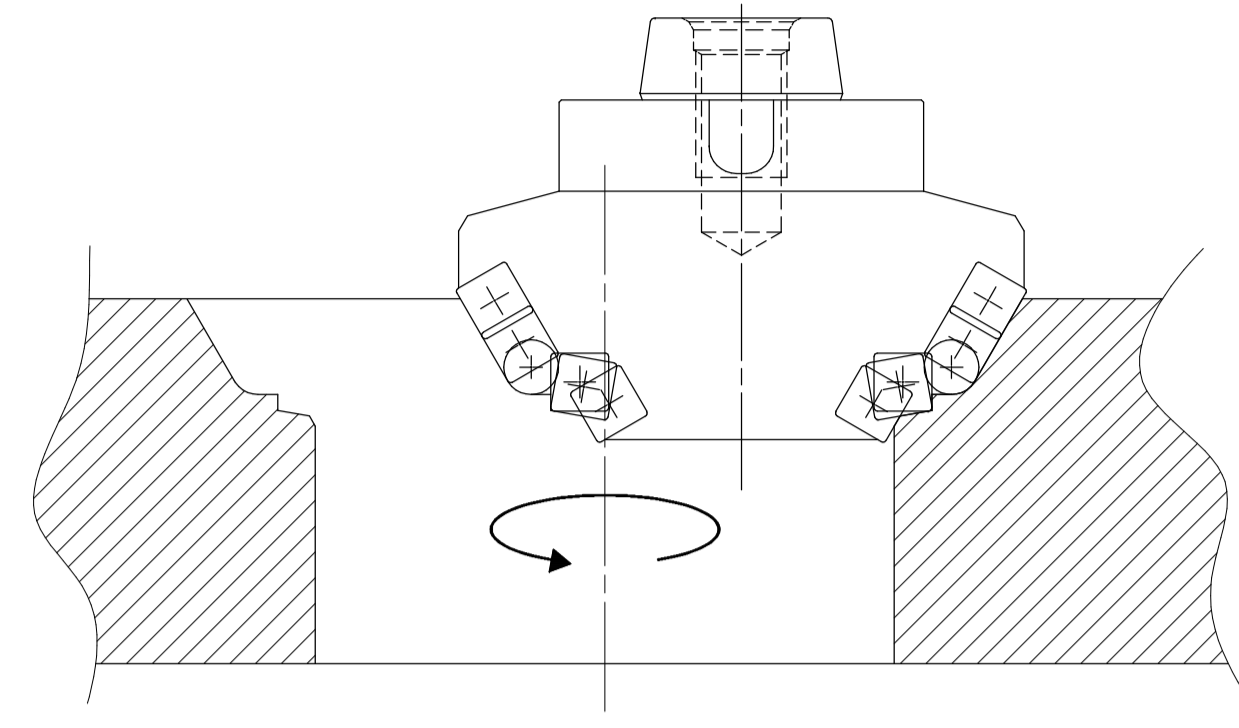
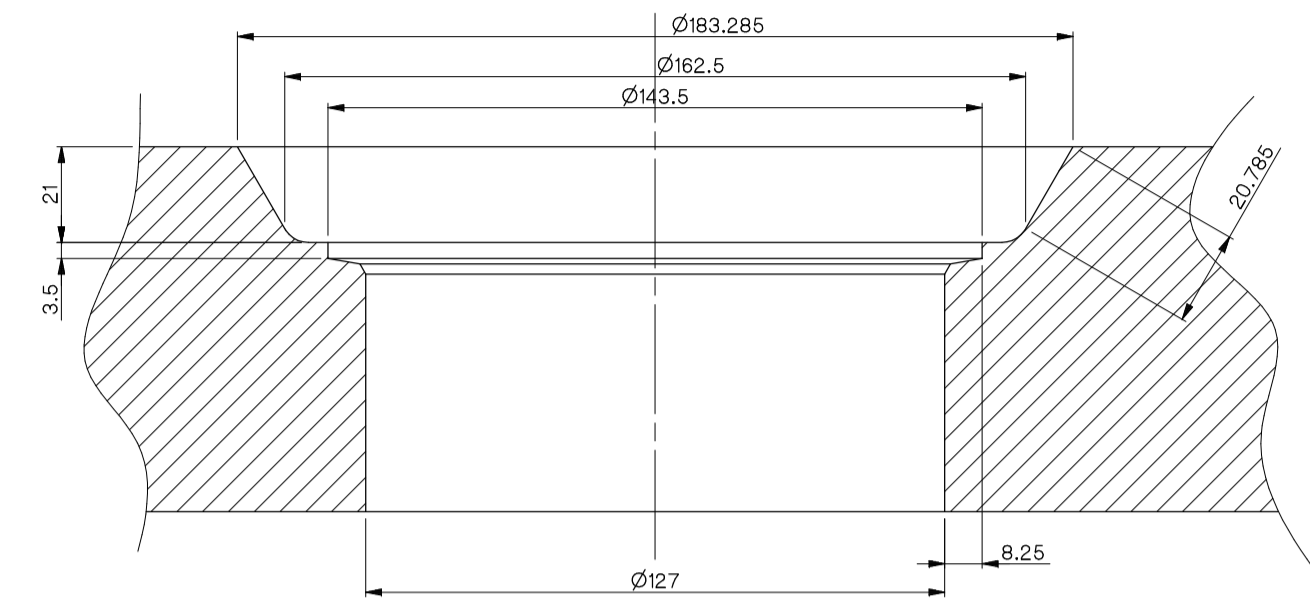

Op. Profile

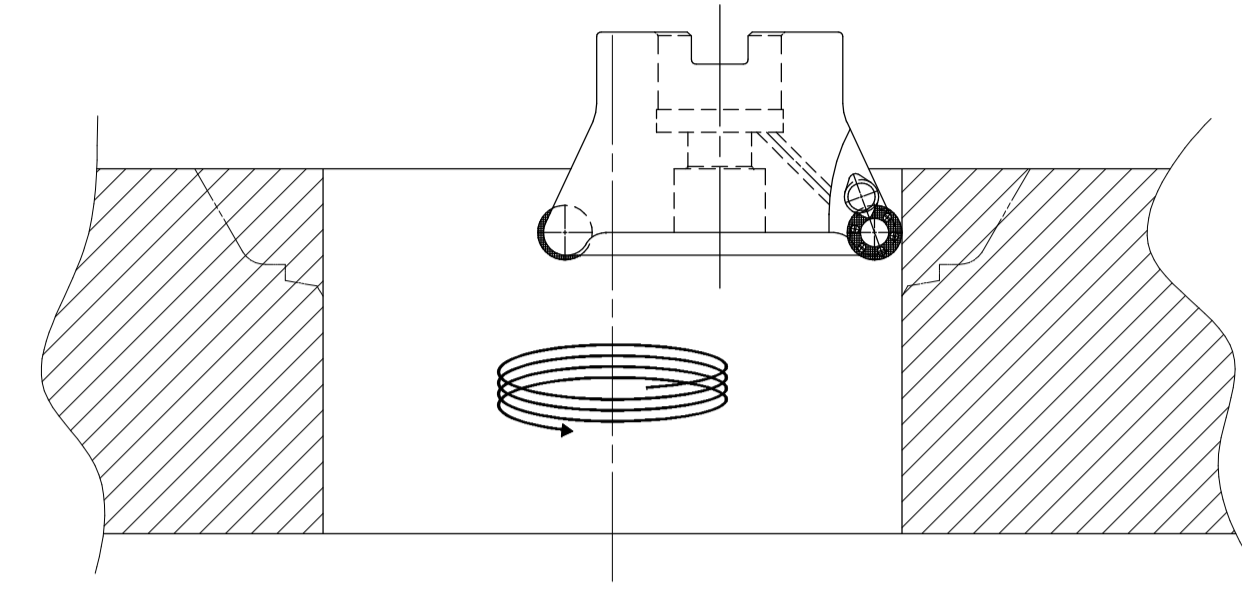

Op. Helicoidal Milling and Boring

EP Style 3

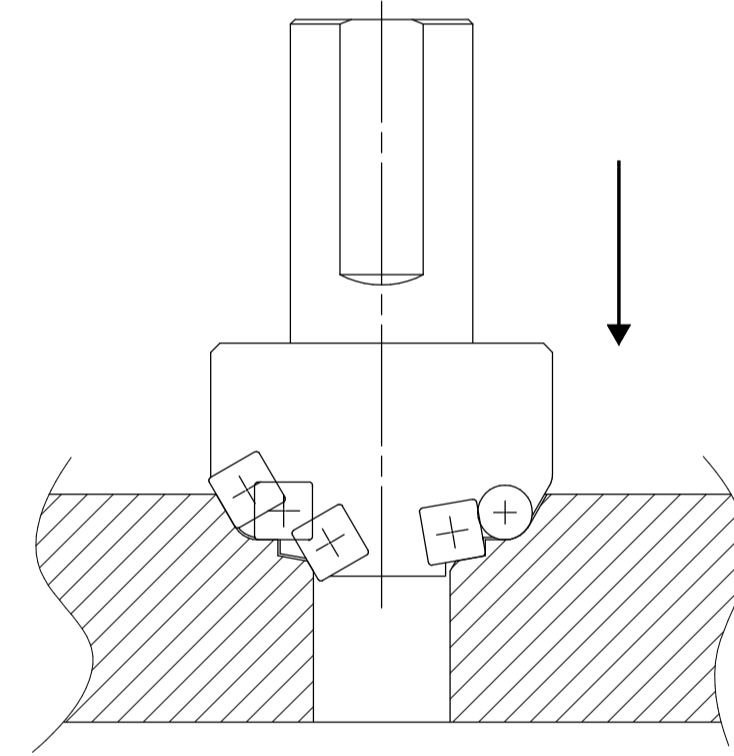
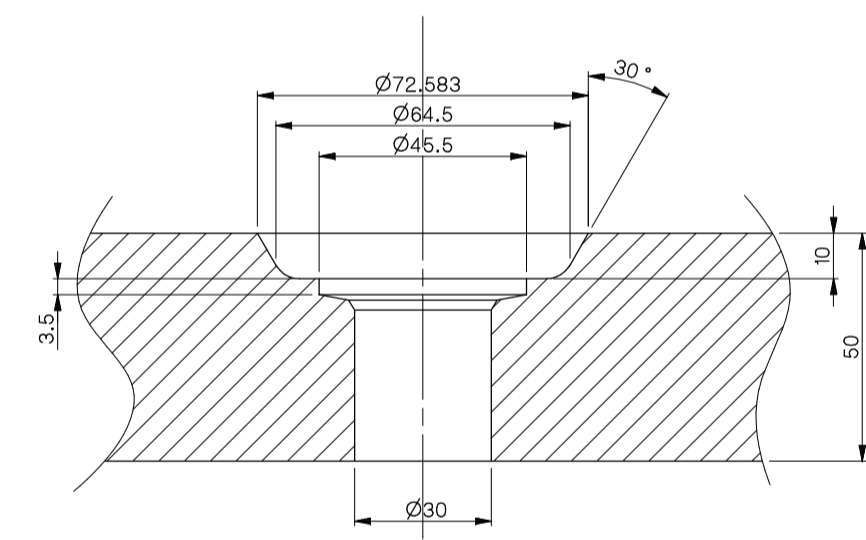

Op. Profile to Plunge

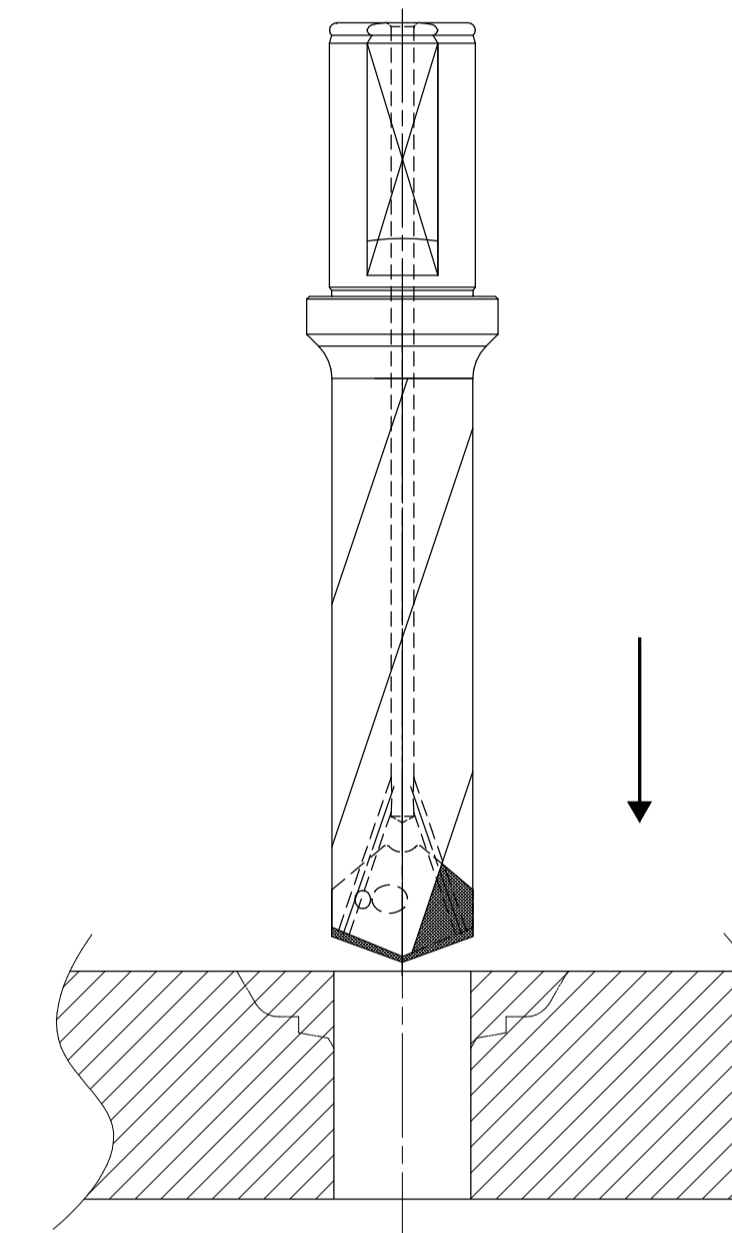

Op. Drilling

EP Style 2

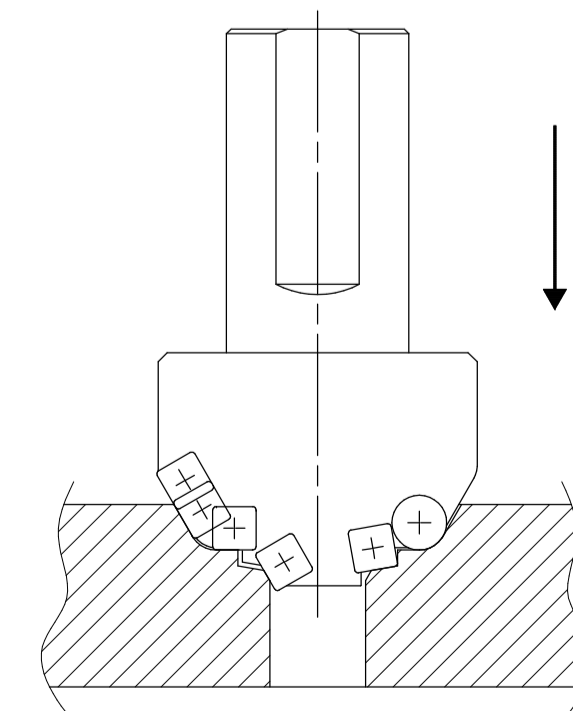
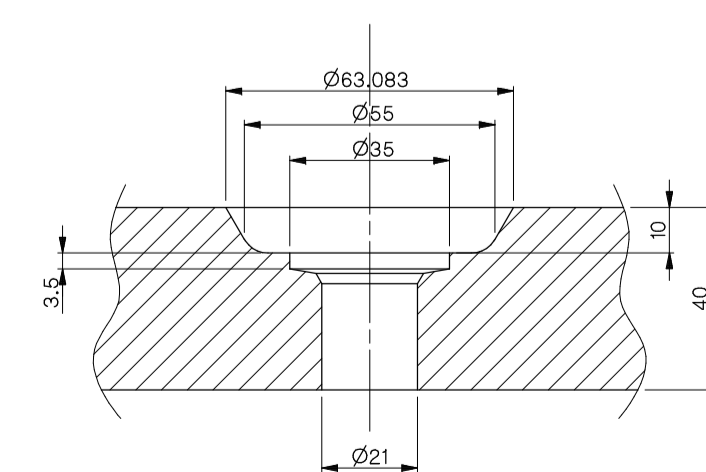

Op. Profile to Plunge

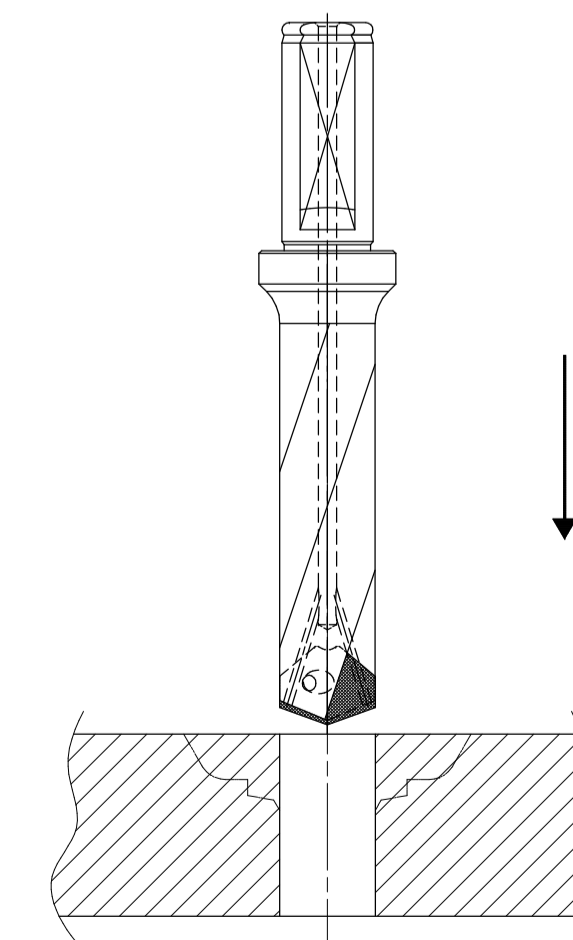

Op. Drilling

EP Style 1