



Bharat Heavy Electricals Limited

(High Pressure Boiler Plant)

Tiruchirappalli – 620014, TAMIL NADU, INDIA

CAPITAL PURCHASE / MATERIALS MANAGEMENT / MANUFACTURING

An ISO 9001
Company

ENQUIRY	Phone: +91 431 257 79 38 Fax : +91 431 252 07 19 Email : tvenkat@bheltry.co.in Web : www.bhel.com
----------------	---

	Enquiry Number: 2620700066	Enquiry Date: 08.08.2007	Due date for submission of quotation: 22.09.2007
--	---	---	---

You are requested to quote the Enquiry number date and due date in all your correspondences. This is only a request for quotation and not an order

Item	Description	Quantity	Delivery (Item required at BHEL on)
10	25 Ton Gantry Crane as per the technical specification & commercial conditions applicable (to be downloaded from web site www.bhel.com or http://tenders.gov.in)	1 No.	30.06.2008

BHEL commercial terms & conditions with Price Bid and Bank Guarantee formats along with technical specifications can be downloaded from BHEL web site <http://www.bhel.com> or from the Government tender website <http://tenders.gov.in> (public sector units > Bharat Heavy Electricals Limited page) under Enquiry reference “2620700066”.

Tenders should reach us before 14:00 hours on the due date Tenders will be opened at 14:30 hours on the due date Tenders would be opened in presence of the tenderers who have submitted their offers and who may like to be present	Yours faithfully, For BHARAT HEAVY ELECTRICALS LIMITED Manager / Capital Purchase / MM / Manufacturing
--	--

PART A**SECTION-I: -QUALIFING CRITERIA**

The BIDDER/VENDOR (OEM) has to compulsorily meet the following requirements to get qualified for consideration of the technical offer for the SUPPLY OF Gantry CRANE

S. No.	PARTICULARS	VENDOR'S RESPONSE
1.0	<p>Only those Bidder/vendor (OEM), who have supplied and commissioned at least ONE 25 Ton capacity GANTRY crane class-3 with minimum span of 18 Mtr and frequency converter drives or higher and such crane is presently working satisfactorily for more than one year after commissioning (on the date of opening of Tender), should quote.</p> <p>However, if such crane has been supplied to BHEL, then it should be presently working satisfactorily for more than six months after its commissioning and acceptance (on the date of opening of Tender) in BHEL.</p> <p>Performance certificate from the customers (minimum 2) regarding satisfactory performance of machine supplied to them in attached format should be enclosed along with technical offer.</p>	
2.0	BHEL reserves the right to verify the information provided by vendor. In case the information provided by vendor is found to be false/ incorrect, the offer shall be rejected.	
3.0	The bidding FIRM should have 'in-house' or 'self-owned' facility for FABRICATION and TESTING at 125 % of the rated capacity	
4.0	The vendor should have minimum 10 years experience in design, fabrication and supply of cranes.	

SECTION – II

The vendors are requested to provide the following details

S. No.	PARTICULARS	VENDOR'S RESPONSE
3.0	Number of Years of Experience of the BIDDER/VENDOR (OEM) in the field of design, manufacture,	

	supply, erection & commissioning of cranes	
4.0	Number of cranes supplied, installed and commissioned till date	
5.0	Number of cranes supplied, installed and commissioned till date in the QUOTED MODEL	
6.0	Number of cranes supplied, installed and commissioned till date for the following category of CUSTOMERS a) Power Utility Boiler Manufacturer b) Equipment Supplier for Process Industries [Heavy Engineering Companies] c) Research Establishments	
7.0	Details on SERVICE-AFTER-SALES Set-Up in India including the Addresses of Agents / Service Centre in India and Asia	
8.0	Any Additional Data to supplement the manufacturing capability of the BIDDER for the subject equipment.	

SECTION – III

Bidder / Vendor (OEM) to note the following

S.No.	REQUIREMENTS	VENDOR'S RESPONSE
9.0	The BIDDER / VENDOR shall submit the offer in TWO PARTS - Technical [with PART A & PART B] & Commercial and Price Bid.	
10.0	The Offer shall contain a comparative statement of Technical Specifications given by BHEL and the Offer Details submitted by the Bidder, against each clause. Where details are required, a mere 'CONFIRMED' or 'COMPLIES' or 'YES' or 'NO-DEVIATION' or similar words in the technical comparative statement may lead to disqualification of the Technical Offer.	
11.0	The Technical Offer shall be supported by Product Catalogue and Data Sheets in ORIGINAL and complete technical details of 'Bought-Out-Items' with copies of Product Catalogue and Selection Criteria	
12.0	The Commercial Offer (given with the Technical Offer) shall contain the Scope of Supply and the Un-Priced Part of the Price-Bid, for confirmation	
13.0	BIDDER has to indicate the Country of Origin for the supply of equipment.	

PERFORMANCE CERTIFICATE

(On Customer's Letter Head)

1. Supplier of the Equipment :

2. Make & Model of the Equipment :

3. Month & Year of Commissioning :

4. Application :

5.
 - a) Crane Type:

 - b) Crane Capacity (Metric Tonnes):

 - c) Crane span :

 - d) Mechanism class :

6. Performance of the Equipment : Best in the market /
(Strike off whichever is not applicable) Satisfactory /
Good /
Average /
Not Satisfactory

7. Any other remarks:

Date:

Signature & Seal of the Authority
Issuing the Performance Certificate

PART B.**TECHNICAL SPECIFICATIONS FOR GANTRY CRANE WITH DOUBLE GIRDERS**

S.No.	PARTICULARS	BHEL SPECIFICATIONS	VENDOR's TECHNICAL OFFER (With Complete Details)
1.0.0	APPLICATION	a. The subject crane is meant for the purpose of handling small to large (within the lifting capacity of the crane) components, bundles of steel sections and sheets & plates [13 Mtr. Long max.] in a large steel storage yard. b. The crane will be put to use for continuous duty with CT, LT and Hoist movements, which may occur simultaneously (within the operating parameters specified under Clause Nos. – 3.1.0, 3.4.0 and 3.5.0). c. The storage yard environment will be open out door area and ambient temperature going up to 40 to 50 ° C.	
2.0.0	SCOPE OF SUPPLY	a. Design as per Tender Specifications b. Detailed Design and Manufacture as per BHEL GENERAL SPECIFICATIONS, given as ANNEXURE-1. c. Assembly and Testing before Despatch d. Supply in Modules / Sub-Assemblies e. Commissioning and Performance Prove-Out at BHEL Works f. Performance Guarantee for 12 months, from the date of commissioning.	<u>SPECIAL NOTE to BIDDER :</u> <i>The SUPPLIER has to abide by the clauses applicable for selection of materials and crane construction, and those clauses irrelevant for semi-gantry crane manufacture may be ignored.</i>

S.No.	PARTICULARS	BHEL SPECIFICATIONS	VENDOR's TECHNICAL OFFER (With Complete Details)
3.0.0	TECHNICAL SPECIFICATIONS		
3.1.0	CAPACITY	Lifting Capacity	
3.1.1	Main Hoist	25 Metric Tonnes	
3.1.2	Auxiliary Hoist	10 Metric Tonnes	
3.2.0	SPAN	Wheel Centre to Wheel Centre Dimensions	
3.2.1	Long Travel (LT)	18,500 mm	
3.2.2	Cross Travel (CT)	3,500 mm	
3.3.0	Height of Lift	10,000 mm [Effective Height of Lift for both the HOISTS]	
3.4.0	DUTY CYCLE	Related to Drive Motor & Mechanisms	
3.4.1	Hoists	40 % E D	
3.4.2	Long Travel	40 % E D	
3.4.3	Cross Travel	40 % E D	
3.5.0	SPEED	Operating / Working Speed [Maximum]	
3.5.1	Main Hoist	7.5 mtrs./minute.	
3.5.2	Auxiliary Hoist	15 mtrs./minute.	
3.5.3	Cross Travel (CT)	30.0 mtrs./minute.	
3.5.4	Long Travel (LT)	70.0 mtrs./minute.	
3.6.0	MOTOR RATINGS	Electric Drive Motor Ratings & Frame Sizes	
3.6.1	Main Hoist	46.5 kW ; Frame Size – 280 M / 6 Pole 40% CDF	
3.6.2	Auxiliary Hoist	30.4 kW ; Frame Size – 250 M / 6 Pole 40% CDF	
3.6.3	Cross Travel (CT)	9.8 kW ; Frame Size – 160 L / 6 Pole 40% CDF	
3.6.4	Long Travel (LT)	2 x 23.7 kW ; Frame Size – 225 M / 6 Pole 40% CDF	
3.7.0	GEAR BOX	Gear Box Sizes	
3.7.1	Main Hoist	HR 850	
3.7.2	Auxiliary Hoist	HR 650	

S.No.	PARTICULARS	BHEL SPECIFICATIONS	VENDOR's TECHNICAL OFFER (With Complete Details)
3.7.3	Cross Travel (CT)	VR 500	
3.7.4	Long Travel (LT)	VR 650 - 2 nos	
3.8.0	ACCELERATION		
3.8.1	Cross Travel (CT)	300 mm / sec.sq.	
3.8.2	Long Travel (LT)	300 mm / sec. sq.	
3.9.0	HOIST ROPE DETAILS	Size and Number of Falls of Rope	
3.9.1	Main Hoist	Dia. 20 mm ; Falls - 8	
3.9.2	Auxiliary Hoist	Dia. 18 mm ; Falls - 4	
3.10.0	CONTROL	Cabin Operation and Remote Control	
3.11.0	Type of Control	Master Control and Radio Remote Control	
3.12.0	Control Voltage	110 V AC	
3.13.0	Input Power Supply	415 ± 10% Volts , 50 ± 3% Hz, 3 Phase- AC	
3.14.0	Duty Class	Class – 3 [Outdoor Service]	
3.15.0	Mechanism Group Classification	M 6	
3.16.0	DESIGN STANDARD	IS – 807 & 3177 / 1999	
3.17.0	Runway Rail Size		
3.17.1	Cross Travel (CT)	ISR 60 Lbs./Yard	
3.17.2	Long Travel (LT)	ISR 105 Lbs/Yard	
3.18.0	Wheel Size		
3.18.1	Cross Travel (CT)	Dia. 320 mm	
3.18.2	Long Travel (LT)	Dia. 630 mm	
3.19.0	Brake Drum Size	Hoist Brake Drum Sizes	
3.19.1	Main Hoist	Dia. 300 mm	
3.19.2	Auxiliary Hoist	Dia. 300 mm	
3.19.3	Cross Travel (CT)	Dia. 160 mm	
3.19.4	Long Travel (LT)	Dia. 200 mm	
3.19.5	Parking brake	Dia. 200 mm - DC brake	

S.No.	PARTICULARS	BHEL SPECIFICATIONS	VENDOR'S TECHNICAL OFFER (With Complete Details)
4.0.0	MAIN FEATURES	Crane Operational Features	
4.1.0	Control System	Frequency Converter type for all motions	
4.2.0	Remote Control	Radio Remote Control for all motions (Microprocessor based)	
4.3.0	Crane Operation	Through Cabin Control and Radio Remote Control with option for control selection	
4.4.0	Operator Cabin	Totally enclosed out door type cabin with fan, light and exhaust fan located on one end of the crane	
5.0.0	STRUCTURAL FABRICATION	Crane Structure Constructional Details	
5.1.0	Bridge / Leg	Box type Construction	
5.2.0	Raw Material	Only steel plates, tested and certified for quality by reputed inspection authorities, shall be used. Test Certificates to be produced for BHEL verification and form part of the documentation.	
5.3.0	Welded Joints	To be followed for Bridge/leg Fabrication	
5.3.1	Number of Joints allowed	For Span upto 23 mtrs. - Two joints For Span 23 mtrs. to 32 mtrs. - Three joints	
5.3.2	Welding Electrodes	a. For all Horizontal Welding E 7018 Electrode only should be used. b. For all Vertical Welding E 7048 Electrode only should be used.	
5.3.3	Welded Joint Testing	All Butt Welded Joints (both compression / tension and flanges / web joints) shall be subjected to 100% X-Ray Testing and X-Ray Films to be produced for BHEL evaluation and form part of the documentation.	

S.No.	PARTICULARS	BHEL SPECIFICATIONS	VENDOR'S TECHNICAL OFFER (With Complete Details)
5.4.0	Splice Joints	NO SPLICE JOINT IS ALLOWED IN GIRDER FABRICATION [Girder has to be of SINGLE PIECE only].	
5.5.0	Leg connection	Leg to bridge connection shall be designed for double shear with fit bolt as per IS-3640 on one end of the bridge and pin connection on the other. LT bogie shall have pin connection with the leg.	
5.6.0	Platform on Girders	The Platforms provided on both the Girders shall be fixed through BOLTED JOINTS with fit bolt as per IS-3640 only.	
5.7.0	Wheel Assembly	The Wheel Assembly coming for Cross Travel (CT) & Long Travel (LT) shall be of LIVE AXLE SYSTEM with L-Type Bearings. [Refer to BHEL Drawing No. 3-M-02R-0011993. Drawing is enclosed and given as ANNEXURE -2]. Bogie type assembly shall be for LT wheels.	
5.8.0	Heat Treatment & NDT Examination	The Trolleys shall be Stress Relieved after welding and NDT examinations. All weldings shall be tested by NDT means [MPI, LPI & RT] after Stress Relieving operation.	
5.9.0	Machining Operation	All mechanical mating surfaces and wheel seating areas are to be machined to the required finish and protected	
5.10.0	Surface Cleaning	Both the Girders and the Trolleys are to be shot blasted or chemically treated for surface cleaning, after completion of all operations but prior to painting.	

S.No.	PARTICULARS	BHEL SPECIFICATIONS	VENDOR'S TECHNICAL OFFER (With Complete Details)
5.11.0	Painting	The crane parts are to be painted as follows : a. One coat of Primer with 25 microns of DFT (Dry Film Thickness) and 48 hours of compulsory curing after painting. b. Two coats of Enamel Paint (Colour – Tractor Orange) each with a DFT of 25 microns and intermittent curing of minimum 16 hours.	
6.0.0	MECHANICAL ELEMENTS		
6.1.0	Gears	Gears in all the Stages shall be helical in design and to be of machined, lapped and hardened.	
6.2.0	Gear Box Casing	Shall be of fabricated type and stress relived by thermal heat-treatment process, prior to machining.	
6.3.0	Rope Drum	Shall be of fabricated type and stress relieved. The circumferential weld joints shall be tested by 100 % X-Ray for quality assurance.	
6.4.0	Type of Coupling	Only GEARED COUPLING to be used a. between Electric Motor and Gear Box b. between Gear Box and Rope Drum c. between Gear Box and Trolley Wheels	
6.5.0	Wheels	The Wheels shall be of Forged and Wheel Tread hardened to 300/350 BHN. Wheels shall be fitted with L-Type Bearings	
6.6.0	Mechanical Joints	Fit Bolts as per IS 3640-1982 for all joints coming in main members and platform with reamed holes	
6.7.0	Pulley Dimension	Rope Pulley diameter shall be 23 times that of Rope diameter	

S.No.	PARTICULARS	BHEL SPECIFICATIONS	VENDOR'S TECHNICAL OFFER (With Complete Details)
6.8.0	Hook	Hook latch shall be provided for both hooks	
6.9.0	Wind Clamp	Wind clamp shall be provided in all four corners	
6.10.0	Roof Covering	Single Roof cover shall be provide for trolley and long travel mechanisms	
6.11.0	Lifting Beam	Lifting beam for handling the components of the trolley in hoist and cross travel mechanisms	
7.0.0	ELECTRICAL ELEMENTS		
7.1.0	Operational Controls	The Crane shall be provided with the following controls : a. Cabin Control [Master Control] b. Radio Remote Control [2 –step Push Button Type , Micro processor based]	
7.2.0	Control Voltage	110 V AC	
7.3.0	Type of Brakes	a. Main Hoist - Thruster Brake b. Auxiliary Hoist – Thruster Brake c. Cross Travel - Thruster Brake d. Long Travel - Thruster Brake e. Parking brake - DC brake	
7.4.0	Protection	All Panels, Limit-Switches and Motors shall have IP 54 protection. (OUTDOOR SERVICE)	
7.5.0	Electric Motors	All Electric Motors shall be as per IS-325 and IS-1231 and also suitable for 300 starts per hour.	

S.No.	PARTICULARS	BHEL SPECIFICATIONS	VENDOR's TECHNICAL OFFER (With Complete Details)
7.6.0	Electric Contactors	All Panels shall have only SIEMENS Contactors and shall be suitable for AC3 Duty Class.	
7.7.0	Contactors Rating	The rating of all Contactors shall be atleast 50% higher than the respective electric motor full load current, at the specified duty cycle.	
7.8.0	Resistance	Stainless steel punched grid resistance continuous rating	
7.9.0	Illumination	a. Four numbers of 500 Watts Halogen Lamps shall be provided under the Bridge b. All Electric Panels shall be provided with suitable illumination for visibility and trouble shooting.	
7.10.0	Controller Steps	A 5-Step Controller has to be provided for a. Main Hoist b. Auxiliary Hoist c. Long Travel d. Cross Travel	
7.11.0	Load Cell for Main Hoist	a. Load Weighing System with LOAD CELL to be fixed / provided at the equalizer pulley. b. The display shall be of 100 mm size (JUMBO)	
7.12.0	Wiring	Wiring shall avoid junction boxes.	
7.13.0	Hoist Limit	Each hoist shall be provided with both rotary and counter weight limits.	
7.14.0	Cabin	Electric Light, Fan, Exhaust-Fan, Warning Bell and Emergency Stop Push Button shall be provided in the Operator Cabin.	

S.No.	PARTICULARS	BHEL SPECIFICATIONS	VENDOR's TECHNICAL OFFER (With Complete Details)
8.0.0	SELECTION of COMPONENTS	The makes of Components or Bought-Out-Items shall be strictly as per the list given below.	
8.1.0	Hoist Hooks	HERMAN MOHTTA / HERCULES / SILPA UDYOG / SMRITI FORGINGS / KARACHIWALA	
8.2.0	Wire Rope	USHA MARTIN / FORT WILLIAM / RA WIRE ROPE	
8.3.0	Electric Motors	GEC / BHARAT BIJLEE / SIEMENS / KEC	
8.4.0	DC Brake Unit	Only BCH make	
8.5.0	Radio Remote Control	Only TELECRANE make (Micro processor type)	
8.6.0	Thruster Brake Unit	ELECTROMAG / SPEED-O-CONTROL / OMEGA	
8.7.0	Limit Switch (Gravity Type)	SIEMENS / INDUSTRIAL SYNDICATE / BCH / SKC / SOC	
8.8.0	Contactors	Only SIEMENS make	
8.9.0	Over-Load-Relay	SIEMENS (THERMAL TYPE)	
8.10.0	HRC Fuses	ENGLISH ELECTRIC / L&T /SIEMENS	
8.11.0	Rotary limit switch	SIEMENS / OMEGA / SOC / INDUSTRIAL SYNDICATE	
8.12.0	Switch fuse unit	ENGLISH ELECTRIC / SIEMENS / GEC	
8.13.0	Moulded case C.B	SIEMENS / L&T	
8.14.0	Pneumatic Time Delay	Only BCH make	
8.15.0	Push - Buttons	SIEMENS / L&T /AIRON	
8.16.0	Connectors	Only ELMAX make	
8.17.0	Couplings	WMI / FENNER / ALFEX	
8.18.0	Bearings	SKF / NBC / ZKL	
8.19.0	Cables	Reputed Makes & ISI Approved	
8.20.0	Bridge Light Fittings	PHILIPS / GE / CROMPTON	

S.No.	PARTICULARS	BHEL SPECIFICATIONS	VENDOR's TECHNICAL OFFER (With Complete Details)
8.21.0	Load Cell	Only IPA make	
8.22.0	Resistance box	OHMARK / BCH	
9.0.0	DOCUMENTS/DETAILS for APPROVAL	The following documents and details are to be submitted for BHEL Approval, prior to taking up the manufacture of the crane.	
9.1.0	Drawings and Documents	<ul style="list-style-type: none"> a. GA Drawing of the Crane. b. GA Drawing of Crab with Trolley c. GA Drawing of Individual Mechanisms. d. Drawings of Bridge, End-Carriage and their connection. e. Sub-Assembly Drawing for Wheels, Hook Blocks, Gear Boxes & Hoist Drums. f. Calculations for Selection of Electric Motors, Gear Reducers, Brakes, Couplings, etc. g. Calculations for Bridge Girder, Crab, End - Carriage and their connections. h. Wiring Diagram with Logic Circuits. i. Cable Selection based on Current Rating. 	

S.No.	PARTICULARS	BHEL SPECIFICATIONS	VENDOR'S TECHNICAL OFFER (With Complete Details)
9.2.0	Technical Details	a. Total Weight of the Crane including all Electrical Equipment b. Total Weight of Trolley including all Electrical Equipment c. Weight of each Bridge assembled and ready for erection with and without Mechanical and Electrical Equipment. d. Weight of each End - Carriage assembled and ready for erection e. Total Weight of Structural, Mechanical and Electrical Equipment and indicated separately also. f. Weight of Operator's Cabin together with all Equipment mounted in it.	
10.0.0	INSPECTION	The following Schedule of Stage Inspections is to be strictly adhered to, prior to dispatch from the Supplier's Works	
10.1.0	STAGE – I	a. Verification of Test Certificate for Raw Materials used for Girders, End-Carriages, Trolleys, Gear Box Casings, etc. b. Verification of X-Ray Report of Butt-Joints coming in the Girders and Random Testing on the Welds, by physical examination. c. Box Girder setting before closing of the Bottom Flanges – for inspecting the quality of welding and presence of waviness d. Trolley Frame Fabrication before setting the Mechanisms e. End – Carriage and legs Fabrication	

S.No.	PARTICULARS	BHEL SPECIFICATIONS	VENDOR's TECHNICAL OFFER (With Complete Details)
10.2.0	STAGE – II	a. Inspection of Bridges and End – Carriages with Wheel Assembly and Alignment checking. b. Verification of Span & Diagonal Dimensions, Checking of Wheel Alignment, Mechanical Assemblies and Total Alignment. c. Free running of the all the Mechanisms.	
10.3.0	STAGE – III [Final Inspection]	a. Measurement of CAMBER in the Bridges. b. Full / Rated Load Test and Deflection Test. c. Deflection and Permanent Set Measurement. d. 25% OVER-LOAD Lifting Ability Check.	
11.0.0	CRANE ERECTION & COMMISSIONING		
11.1.0	Mechanical Erection	Erection of the Crane will be done by BHEL, as per the guidelines furnished in the Erection Manual given	
11.2.0	Crane Commissioning	Commissioning of the Crane and Performance Prove –Out for the Crane's Capacity and Smooth Functioning of the Crane (at BHEL Works) shall be the RESPONSIBILITY of the supplier.	
12.0.0	O & M MANUALS	Each Crane shall be provided with THREE Copies of Erection, Operation & Maintenance Manual hard copy as well as soft copy in CD, containing the following technical details	

S.No.	PARTICULARS	BHEL SPECIFICATIONS	VENDOR'S TECHNICAL OFFER (With Complete Details)
12.1.0	Drawings & Details	a. Crane GA Drawing b. Crab Assembly Drawing c. Total Crane Wiring Schematics d. Detailed Wiring Diagrams for Sub-Systems / Panels e. VVVF Drive's Logic Circuits f. Wheel Assembly Drawings g. Bottom Block Assembly Drawing h. Gear Box Assembly Drawings i. Coupling Drawing and Details j. Specifications/Ratings of All Bought-Out-Items k. Warranty / Guarantee Card for all Bought-Out-Items l. Trouble Shooting Chart for Main and all Sub-Systems	
13.0.0	PERFORMANCE GUARANTEE	The Performance of the Total Crane and/or the Components / Sub-Assemblies / Bought-Out-Items shall be guaranteed for a minimum period of twelve months from the date of performance acceptance at BHEL Works.	

THIS DRAWING IS OUR SOLE PROPERTY AND SHOULD NOT BE USED IN ANY FORM FOR ANY PURPOSE WITHOUT THE WRITTEN PERMISSION OF BHARAT HEAVY ELECTRICALS LIMITED, TRICHIRAPPALLI - 620 014.

ALL DIMENSIONS ARE IN MM

SL. No.	W.D. (WHEEL DIA) IN MM	RAIL SIZE	A	B	D	E	F	ØG	H	ØJ	K	L	Ød	M (KEY)	N	P	Q	S	R	COUPLING No.	SKF BRG No. & BRG. SIZE	TOTAL WEIGHT IN Kg. FOR DRIVE & IDLE
16	800/850	CR-100 CR-120	190	450	80	210	150	152	140	130	212	255	32	32x18x130	687	588	20	150	80	107	22330 150x320x108	870.00 845.00
15		CR-80	168	420	80	180	110	152	125	110	212	255	32	28x16x115	687	588	20	150	80	106	22330 150x320x108	796.00 775.00
14		CR-100 CR-120	190	450	80	210	150	152	140	130	212	255	32	32x18x130	642	588	20	150	80	107	22330 150x320x108	808.00 784.00
13	710/750	CR-100 CR-120	180	420	71	210	150	132	125	110	180	224	32	28x16x115	607	517	20	130	80	106	22326 130x280x93	728.50 711.50
12		CR-80	180	400	71	180	110	132	125	110	180	224	32	28x16x115	607	517	20	130	80	106	22326 130x280x93	653.00 636.00
11	630/680	CR-80/CR-100 & CR-120	180	420	71	210	150	132	125	110	180	224	32	28x16x115	567	517	20	130	80	106	22326 130x280x93	629.00 611.50
10		90-105 Lbs/Yd CR-80	150	365	60	180	105	111	110	90	160	190	26	25x14x100	547	462	20	120	60	105	22322 110x240x80	448.00 434.50
9		CR-80 CR-100	160	375	60	180	125	111	110	90	160	190	26	22x14x100	482	462	20	120	60	105	22322 110x240x80	253.00 245.50
8	500/550	CR-80	150	360	50	180	125	91	105	80	125	160	26	22x14x90	445	395	20	100	50	104	22318 90x190x64	389.00 378.00
7		60/75/90 & 105 Lbs/Yd	150	360	50	180	105	91	105	80	125	160	26	22x14x90	445	395	20	100	50	104	22318 90x190x64	301.00 294.00
6	400/450	CR-80 CR-100	150	360	50	180	125	91	105	80	125	160	26	22x14x90	395	395	20	100	50	104	22318 90x190x64	253.00 245.50
5		90 Lbs/Yd 105 Lbs/Yd	145	315	40	180	105	76	85	70	112	140	22	20x12x75	375	345	16	90	50	103	22315 75x160x55	197.00 192.00
4	320/370	75 / 90 & 105 Lbs/Yd CR-80	145	315	40	180	105	76	85	70	112	140	22	20x12x75	345	345	16	90	50	103	22315 75x160x55	162.00 157.00
3		50 SQ.BAR 60 Lbs/Yd 75 Lbs/Yd	112.5	260	40	125	85	61	65	55	85	112	17	16x10x55	312	287	16	80	50	102	22312 60x130x46	118.50 118.00
2	250/280	50 SQ.BAR 60 / 90 & 105 Lbs/Yd	105	250	32	125	85	61	65	55	76	100	17	16x10x55	254	249	12	60	40	102	22212 60x110x28	66.00 63.00
1	200/230	50 Lbs/Yd 50 SQ.BAR 60 Lbs/Yd	95	220	32	100	67	46	55	40	71	95	17	12x8x45	239	232	12	65	40	101	22309 45x100x36	51.00 50.00

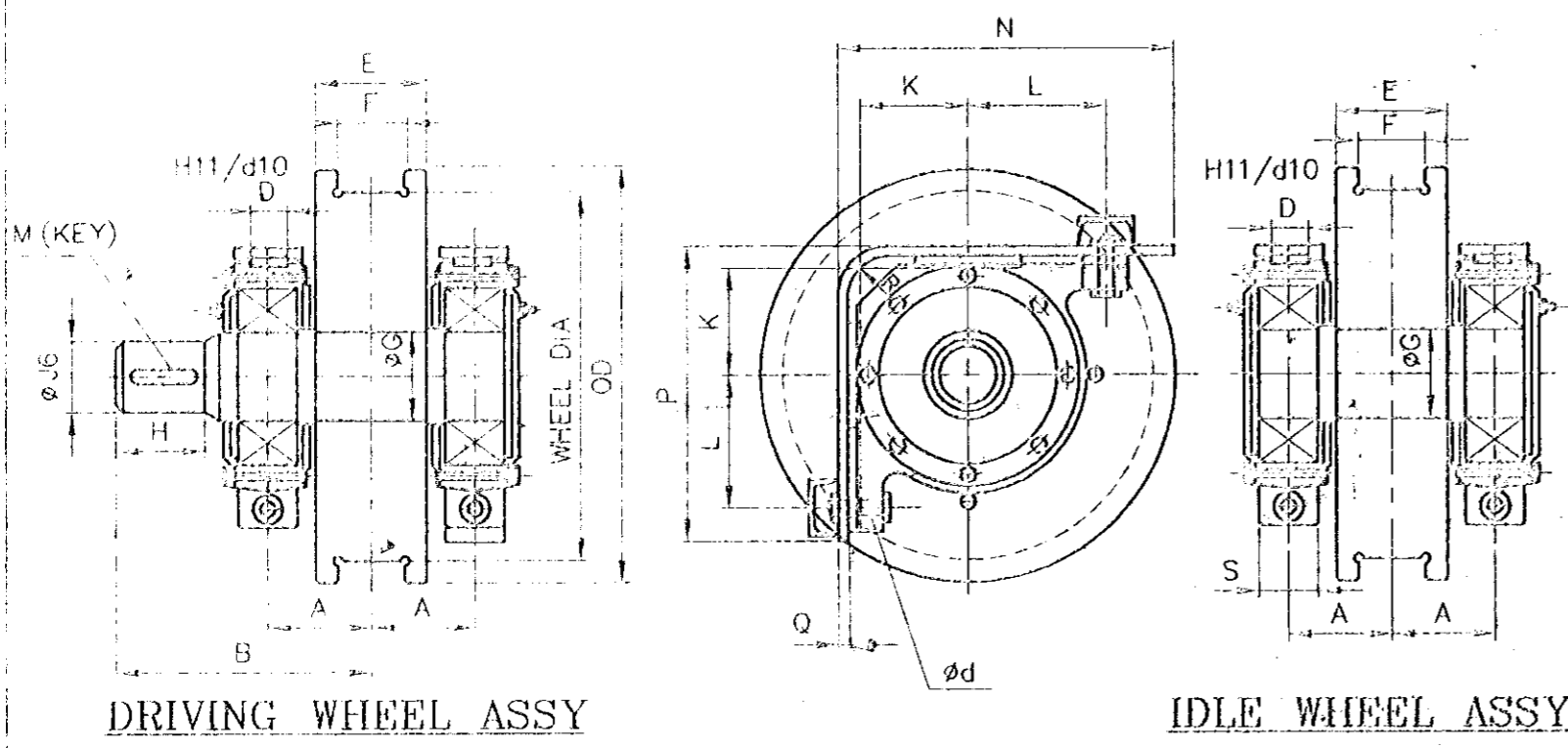

MATERIAL :- SHAFT - 45CB/IS:4283.
WHEEL - 55CB/IS:5517.
FORGED.
THREAD PORTION WHEEL HARDNESS 300 TO 350 (BHN)

No. of Pieces		DESCRIPTION	MATERIAL	STANDARD	NET.WT.IN KGS.	DRAWING No.	ITEM No.
REFERENCE				COMPONENT CODE: 29	EQUIPMENT CODE: 00		
SCALE		DRAWN	CHECKED	APPROVED	DATE	ALTERATIONS	DCN. REF. DATE SIGN. INDEX
					20-10-2000		
MACHINE: CRANE WHEEL ASSY						TYPE: GENERAL	
TITLE: STANDARD CRANE WHEEL ASSY						DRAWING No. 3-M-02R-11993	
No. of Sheets						Sheet No.	