



The Heavy Electricals Equipment Plant (HEEP) located in Haridwar, India is one of the major manufacturing plants of Bharat Heavy Electricals Ltd. The core business of HEEP includes design and manufacture of large steam and gas turbines, turbo generators, Defense Items and so on.

Details of items details as below:

SI. NO.	MAT CODE	ITEM DISCREPTION	Quantity (Nos)	Delivery (Days)
1	W97013311057	NUT, SELF-LOCKING, M12 UNI7473 MATL :6S, FINISH : ZINCO-NICKEL. P/N 211809248 N.STD:UNI 7473 SIZE: P/N 211809248	200	30
2	W97013312045	NUT, SELF-LOCKING, M10 UNI 7474, MATL : 6S, FINISH : ZINCO-NICKEL N.STD:UNI 7474 SIZE: P/N 211809339	100	30
3	W97013312061	NUT, SELF-LOCKING, M12X1.5 UNI 7474, MATL: 6S, FINISH : ZINCO-NICKEL N.STD:UNI 7474 SIZE: P/N 211809342	100	30
4	W97013312231	NUT, SELF-LOCKING, M12X1.25 U NI 7474, MATL : 6.8, FINISH:ZINCO-NICKEL SIZE: 211809355	100	30
5	W97013414093	WASHER 19X34 (FOR HEX HEAD SCREW OF SIZE:M18)AS PER UNI 6592 OR EQUIVALNET STD. DIN 125A/ISO:7089/IS:2016(TYPE -A)ALSO ACCEPTABLE, MATERIAL: STEEL R80(CARBON STEEL HAVING MIN. UTS OF 785 MPA, HARDNESS CLASS: 200 HV), COATING:ZINCO-NICKEL, DIMENSION,TOLERANCE AND DETAILS AS PER GOVERNING STD. SIZE: P/N 210878209	100	30
6	W97013311022	NUT, SELF-LOCKING, M8 UNI 7473 MATL : 6S, FINISH : ZINCO-NICKEL N.STD:UNI 7473 SIZE: P/N 211809244	800	30
7	W97013407496	WASHER, SPRING, LOCK, SINGLE COIL, RECTANGULAR SECTION, TYPEB (WITH FLAT ENDS),DIA 4.1 (SUITABLE FOR SCREW SIZE M4) AS PER IS:3063 OR EQUIVALENT STD -DIN 127 B/ UNI1751 B, MAT : AISI 304(A2-70),ALT.MATERIAL AISI 316 (A4-70) OR AISI 431 (C3-100)ACCEPTABLE,FINISH: PASSIVATION	100	30

		SIZE: P/N 218606441		
8	W97013407500	WASHER, SPRING, LOCK, SINGLE COIL, RECTANGULAR SECTION, TYPEB(WITH FLAT ENDS),DIA 10.2 (SUITABLE FOR SCREW SIZE M10) AS PER IS:3063 OR EQUIVALENT STD -DIN 127 B/ UNI1751 B, MAT: AISI 304(A2-70),ALT. MATERIAL AISI 316 (A4-70) OR AISI 431 (C3-100) ACCEPTABLE, FINISH:PASSIVATION SIZE: P/N 218606446	100	30
9	W97013407518	WASHER, SPRING, LOCK, SINGLE COIL, RECTANGULAR SECTION, TYPEB (WITH FLAT ENDS),DIA 8.2 (SUITABLE FOR SCREW SIZE M8) AS PER IS:3063 OR EQUIVALENT STD -DIN 127 B/ UNI1751 B, MAT: AISI 304(A2-70),ALT. MATERIAL AISI 316 (A4-70) OR AISI 431 (C3-100) ACCEPTABLE, FINISH:PASSIVATION SIZE: P/N 218606445	100	30

1. ALL VENDORS TO PROVIDE POINT WISE REPLY/CONFIRMATION ALONG WITH RELEVANT SUPPORTING DOCUMENTS TO EACH AND EVERY POINT OF PRE-QUALIFICATION REQUIREMENT/PQR FOR ALL ENQUIRY ITEMS. NONCOMPLIANCE OF THESE MAY LEAD TO REJECTION OF OFFER AS THESE ARE ESSENTIAL CONDITION FOR PARTICIPATING IN TENDER ENQUIRY
2. KINDLY UPLOAD/ATTACH THE SPECIFICATION DETAILS/ CATALOGUE OF OFFERED ITEMS.
3. KINDLY ARRANGE TO **SUBMIT TECHNO-COMMERCIAL CHECKLIST** ALONG WITH YOUR OFFER.
4. VENDOR TO CONFIRM TO PROVIDE MATERIAL & DIMENSIONAL TEST CERTIFICATES AS PER ENQUIRY DOCUMENTS ALONG WITH MATERIAL DISPATCH.
5. VENDOR TO CONFIRM TO PROVIDE DOCUMENTS KEEPING PROPER CORRELATION WITH PO ITEMS AND THEIR QUANTITY.
6. VENDOR TO CONFIRM TO PROVIDE CERTIFICATE OF CONFORMANCE ALONG WITH MATERIAL DISPATCH.
7. VENDOR TO CONFIRM TO PROVIDE NON-REMOVABLE IDENTIFICATION OF ALL ITEMS AND THEIR REPORT ACCORDINGLY.

QUALIFYING CONDITIONS for all types of Fasteners

Following can quote:

- a) Manufacturer
- b) Authorized Dealer/Distributor
- c) Stockist
- d) Supplier

Sl.	PQR Requirement	Vendor Response	Vendor Response (Yes / No / Remarks, if any)
1.	who can manufacture or supply ALL TYPES Fasteners as per national and equivalent International standards	Vendor to confirm	
2.	who can provide Material Test Certificate OR Certificate of Conformance (COC) (<i>also known as Certificate of Conformity or Certificate of Compliance</i>)	Vendor to confirm	

**TECHNICAL PARAMETERS CHECK LIST
DATA VALUES TO BE FILLED AND CONFIRMED BY VENDOR**

ITEM MATCODE W97013414093

ITEM NAME WASHER 19X34

ITEM PART NO P/N 210878209

COMMERCIAL EQUIVALENTS

ALL DIMENSIONS IN MM

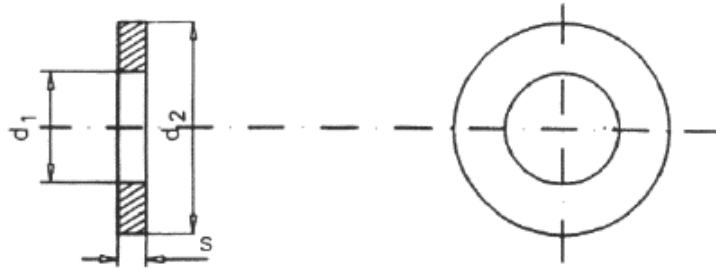

NOTE: Vendor to input parameters based on the specification of the Washer quoted.					
SN.	DESCRIPTION	SPECIFICATION #	TOLERANCE	RESPONSE TYPE	VENDOR RESPONSE
1	ITEM	WASHER 19X34	-	To confirm →	
2	SPECIFICATION & DIMENSIONS	UNI 6592/ DIN-125A / ISO-7089/ IS-2016 TYPE-A	-	To specify →	
3	DIA (d1)	19	+0.033 0.0	To input →	
4	DIA (d2)	34	±0.8	To input →	
5	THICKNESS (s)	3	±0.22	To input →	
6	MATERIAL	STEEL R80	-	To confirm →	
7	FINISH	ZINCO-NICKEL/ ZINC BLUE/ CADMIUM CHROMATE	-	To confirm →	
8	CERTIFICATION	MATERIAL TEST CERTIFICATE	-	Confirm to supply →	
9	CERTIFICATION	Certificate of Conformance / Compliance (COC)	-	Confirm to supply →	
10	VENDOR REMARKS				

Vendor to specify the specification number of the offered item.

**TECHNICAL PARAMETERS CHECK LIST
DATA VALUES TO BE FILLED AND CONFIRMED BY VENDOR**

ITEM MATCODE W97013312045

ITEM NAME NUT, SELF-LOCKING, M10

ITEM PART NO P/N 211809339

COMMERCIAL EQUIVALENTS

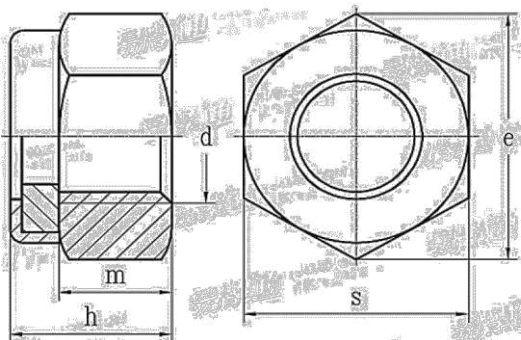

NOTE: Vendor to input parameters based on the specification of the Washer quoted.					
SN.	DESCRIPTION	SPECIFICATION #	TOLERANCE	RESPONSE TYPE	VENDOR RESPONSE
1	ITEM	NUT, SELF-LOCKING	-	To confirm →	
2	SPECIFICATION & DIMENSIONS	UNI 7474 DIN 985	-	To specify →	
3	THREAD SIZE (d)	M10 X 1.5	6H	To input →	
4	NUT HEIGHT (m), MIN.	5	-0.25	To input →	
5	THICKNESS (h), MAX	10	-0.35	To input →	
6	FLAT TO FLAT (s)	17	-0.37	To input →	
7	LOCKING ELEMENT	POLYAMIDE/ NYLON	-	To confirm →	
8	MATERIAL	STEEL CLASS 6S	-	To confirm →	
9	FINISH	ZINCO-NICKEL/ ZINC BLUE/ CADMIUM CHROMATE	-	To confirm →	
10	CERTIFICATION	MATERIAL TEST CERTIFICATE	-	Confirm to supply →	
11	CERTIFICATION	Certificate of Conformance / Compliance (COC)	-	Confirm to supply →	
12	VENDOR REMARKS				

Vendor to specify the specification number of the offered item.

TECHNICAL PARAMETERS CHECK LIST
DATA VALUES TO BE FILLED AND CONFIRMED BY VENDOR

ITEM MATCODE W97013407518

ITEM NAME WASHER, SPRING, LOCK, SINGLE COIL, TYPE-B

ITEM PART NO P/N 218606445

COMMERCIAL EQUIVALENTS

ALL DIMENSIONS IN MM

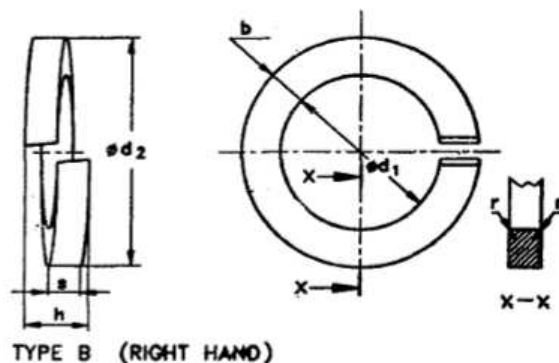

NOTE: Vendor to input parameters based on the specification of the Washer quoted.					
SN.	DESCRIPTION	SPECIFICATION #	TOLERANCE	RESPONSE TYPE	VENDOR RESPONSE
1	ITEM	WASHER, SPRING, LOCK, SINGLE COIL, TYPE-B	-	To confirm →	
2	SPECIFICATION & DIMENSIONS	IS-3063/DIN127B/UNI 1751B	-	To specify →	
3	DIA (d1)	8.1	+0.4 0.0	To input →	
4	THICKNESS (b)	3	±0.15	To input →	
5	DIA (d2)	14.8 MAX	-	To input →	
6	THICKNESS (s)	2	±0.1	To input →	
7	HEIGHT (h)	4.0 TO 4.7	-	To input →	
8	MATERIAL	AISI 304/ AISI 316/ AISI 431	-	To confirm →	
9	FINISH	PASSIVATION	-	To confirm →	
10	CERTIFICATION	MATERIAL TEST CERTIFICATE	-	Confirm to supply →	
11	CERTIFICATION	Certificate of Conformance / Compliance (COC)	-	Confirm to supply →	
12	VENDOR REMARKS				

Vendor to specify the specification number of the offered item.

TECHNICAL PARAMETERS CHECK LIST
DATA VALUES TO BE FILLED AND CONFIRMED BY VENDOR

ITEM MATCODE W97013407500

ITEM NAME WASHER, SPRING, LOCK, SINGLE COIL, TYPE-B

ITEM PART NO P/N 218606446

COMMERCIAL EQUIVALENTS

ALL DIMENSIONS IN MM

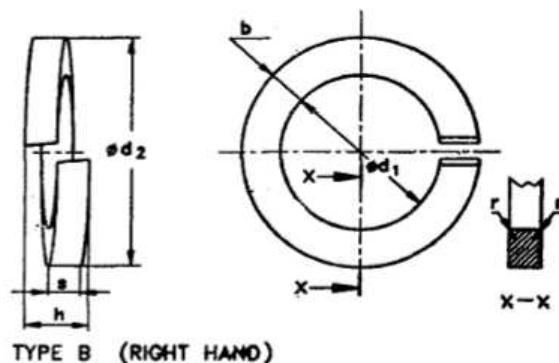

NOTE: Vendor to input parameters based on the specification of the Washer quoted.					
SN.	DESCRIPTION	SPECIFICATION #	TOLERANCE	RESPONSE TYPE	VENDOR RESPONSE
1	ITEM	WASHER, SPRING, LOCK, SINGLE COIL, TYPE-B	-	To confirm →	
2	SPECIFICATION & DIMENSIONS	IS-3063/DIN127B/UNI 1751B	-	To specify →	
3	DIA (d1)	10.2	+0.5 0.0	To input →	
4	THICKNESS (b)	3.5	±0.2	To input →	
5	DIA (d2)	18.1 MAX	-	To input →	
6	THICKNESS (s)	2.2	±0.15	To input →	
7	HEIGHT (h)	4.4 TO 5.2	-	To input →	
8	MATERIAL	AISI 304/ AISI 316/ AISI 431	-	To confirm →	
9	FINISH	PASSIVATION	-	To confirm →	
10	CERTIFICATION	MATERIAL TEST CERTIFICATE	-	Confirm to supply →	
11	CERTIFICATION	Certificate of Conformance / Compliance (COC)	-	Confirm to supply →	
12	VENDOR REMARKS				

Vendor to specify the specification number of the offered item.

**TECHNICAL PARAMETERS CHECK LIST
DATA VALUES TO BE FILLED AND CONFIRMED BY VENDOR**

ITEM MATCODE W97013312061

ITEM NAME NUT, SELF-LOCKING, M12X1.5

ITEM PART NO P/N 211809342

COMMERCIAL EQUIVALENTS

Dimensions in mm.

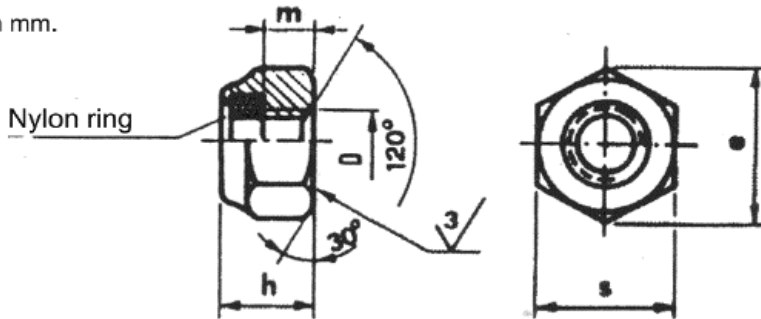

NOTE: Vendor to input parameters based on the specification of the Washer quoted.					
SN.	DESCRIPTION	SPECIFICATION #	TOLERANCE	RESPONSE TYPE	VENDOR RESPONSE
1	ITEM	NUT, SELF-LOCKING	-	To confirm →	
2	SPECIFICATION & DIMENSIONS	UNI 7474 DIN 982	-	To specify →	
3	THREAD SIZE (D)	M12 X 1.5	6H	To input →	
4	NUT HEIGHT (h)	12	-0.43	To input →	
5	THICKNESS (m)	6	-0.3	To input →	
6	FLAT TO FLAT (S)	19	-0.33	To input →	
7	LOCKING ELEMENT	NYLON	-	To confirm →	
8	MATERIAL	STEEL CLASS 6S	-	To confirm →	
9	FINISH	ZINCO-NICKEL/ ZINC BLUE/ CADMIUM CHROMATE	-	To confirm →	
10	CERTIFICATION	MATERIAL TEST CERTIFICATE	-	Confirm to supply →	
11	CERTIFICATION	Certificate of Conformance / Compliance (COC)	-	Confirm to supply →	
12	VENDOR REMARKS				

Vendor to specify the specification number of the offered item.

TECHNICAL PARAMETERS CHECK LIST
DATA VALUES TO BE FILLED AND CONFIRMED BY VENDOR

ITEM MATCODE W97013407496

ITEM NAME WASHER, SPRING, LOCK, SINGLE COIL, TYPE-B

ITEM PART NO P/N 218606441

COMMERCIAL EQUIVALENTS

ALL DIMENSIONS IN MM

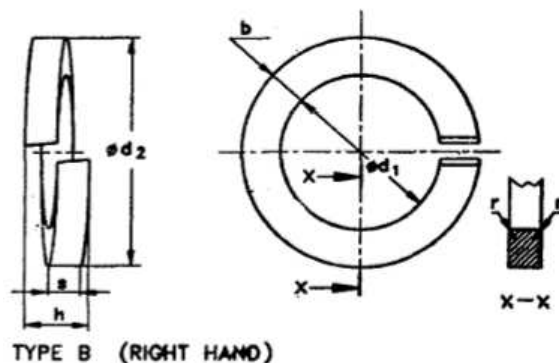

NOTE: Vendor to input parameters based on the specification of the Washer quoted.					
SN.	DESCRIPTION	SPECIFICATION #	TOLERANCE	RESPONSE TYPE	VENDOR RESPONSE
1	ITEM	WASHER, SPRING, LOCK, SINGLE COIL, TYPE-B	-	To confirm →	
2	SPECIFICATION & DIMENSIONS	IS-3063/DIN127B/UNI 1751B	-	To specify →	
3	DIA (d1)	4.1	+0.3 0.0	To input →	
4	THICKNESS (b)	1.5	±0.1	To input →	
5	DIA (d2)	7.6 MAX	-	To input →	
6	THICKNESS (s)	0.9	±0.1	To input →	
7	HEIGHT (h)	1.8 TO 2.1	-	To input →	
8	MATERIAL	AISI 304/ AISI 316/ AISI 431	-	To confirm →	
9	FINISH	PASSIVATION	-	To confirm →	
10	CERTIFICATION	MATERIAL TEST CERTIFICATE	-	Confirm to supply →	
11	CERTIFICATION	Certificate of Conformance / Compliance (COC)	-	Confirm to supply →	
12	VENDOR REMARKS				

Vendor to specify the specification number of the offered item.

**TECHNICAL PARAMETERS CHECK LIST
DATA VALUES TO BE FILLED AND CONFIRMED BY VENDOR**

ITEM MATCODE W97013311022

ITEM NAME NUT, SELF-LOCKING, M8

ITEM PART NO P/N 211809244

COMMERCIAL EQUIVALENTS

DIMENSIONS ARE IN MM

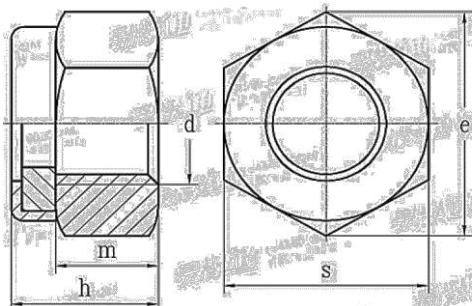

NOTE: Vendor to input parameters based on the specification of the Washer quoted.

SN.	DESCRIPTION	SPECIFICATION #	TOLERANCE	RESPONSE TYPE	VENDOR RESPONSE
1	ITEM	NUT, SELF-LOCKING	-	To confirm →	
2	SPECIFICATION & DIMENSIONS	UNI 7473 DIN 982	-	To specify →	
3	THREAD SIZE (d)	M8 X 1.25	6H	To input →	
4	NUT HEIGHT (m), MIN.	6.4	-0.36	To input →	
5	THICKNESS (h), MAX	10.6	-0.43	To input →	
6	FLAT TO FLAT (s)	13	-0.27	To input →	
7	LOCKING ELEMENT	POLYAMIDE/NYLON	-	To confirm →	
8	MATERIAL	STEEL GRADE 6S	-	To confirm →	
9	FINISH	ZINCO-NICKEL/ ZINC BLUE/ CADMIUM CHROMATE	-	To confirm →	
10	CERTIFICATION	MATERIAL TEST CERTIFICATE	-	Confirm to supply →	
11	CERTIFICATION	Certificate of Conformance / Compliance (COC)	-	Confirm to supply →	
12	VENDOR REMARKS				

Vendor to specify the specification number of the offered item.

**TECHNICAL PARAMETERS CHECK LIST
DATA VALUES TO BE FILLED AND CONFIRMED BY VENDOR**

ITEM MATCODE W97013312231

ITEM NAME NUT, SELF-LOCKING, M12X1.25

ITEM PART NO P/N 211809355

COMMERCIAL EQUIVALENTS

Dimensions in mm.

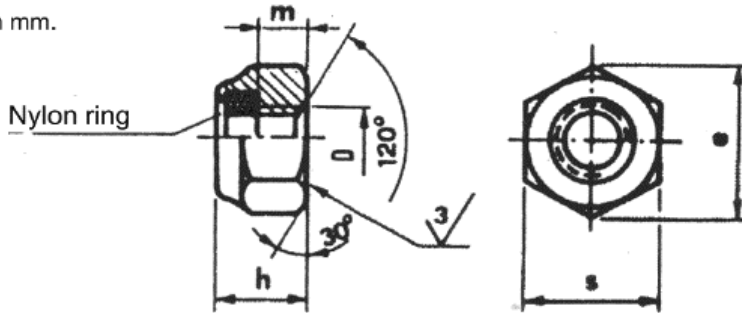

NOTE: Vendor to input parameters based on the specification of the Washer quoted.					
SN.	DESCRIPTION	SPECIFICATION #	TOLERANCE	RESPONSE TYPE	VENDOR RESPONSE
1	ITEM	NUT, SELF-LOCKING	-	To confirm →	
2	SPECIFICATION & DIMENSIONS	UNI 7474 DIN 982/985	-	To specify →	
3	THREAD SIZE (D)	M12 X 1.25	6H	To input →	
4	NUT HEIGHT (h)	12	-0.43	To input →	
5	THICKNESS (m)	6	-0.3	To input →	
6	FLAT TO FLAT (S)	19	-0.33	To input →	
7	LOCKING ELEMENT	NYLON	-	To confirm →	
8	MATERIAL	STEEL CLASS 6S	-	To confirm →	
9	FINISH	ZINCO-NICKEL/ ZINC BLUE/ CADMIUM CHROMATE	-	To confirm →	
10	CERTIFICATION	MATERIAL TEST CERTIFICATE	-	Confirm to supply →	
11	CERTIFICATION	Certificate of Conformance / Compliance (COC)	-	Confirm to supply →	
12	VENDOR REMARKS				

Vendor to specify the specification number # of the offered item.

TECHNICAL PARAMETERS CHECK LIST
DATA VALUES TO BE FILLED AND CONFIRMED BY VENDOR

ITEM MATCODE W97013311057

ITEM NAME NUT, SELF-LOCKING, M12X1.75

ITEM PART NO P/N 211809248

COMMERCIAL EQUIVALENTS

Dimensions in mm.

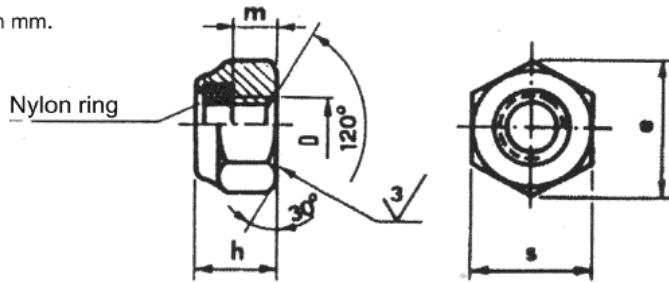

NOTE: Vendor to input parameters based on the specification of the Washer quoted.

SN.	DESCRIPTION	SPECIFICATION #	TOLERANCE	RESPONSE TYPE	VENDOR RESPONSE
1	ITEM	NUT, SELF-LOCKING	-	To confirm →	
2	SPECIFICATION & DIMENSIONS	UNI 7473 DIN 982	-	To specify →	
3	THREAD SIZE (D)	M12 X 1.75	6H	To input →	
4	NUT HEIGHT (h)	14.8	-0.43	To input →	
5	THICKNESS (m)	9.6	-0.36	To input →	
6	FLAT TO FLAT (S)	19	-0.33	To input →	
7	LOCKING ELEMENT	NYLON	-	To confirm →	
8	MATERIAL	STEEL CLASS 6S	-	To confirm →	
9	FINISH	ZINCO-NICKEL/ ZINC BLUE/ CADMIUM CHROMATE	-	To confirm →	
10	CERTIFICATION	MATERIAL TEST CERTIFICATE	-	Confirm to supply →	
11	CERTIFICATION	Certificate of Conformance / Compliance (COC)	-	Confirm to supply →	
12	VENDOR REMARKS				

Vendor to specify the specification number of the offered item.

TECHNO-COMMERCIAL CHECKLIST

SL. NO.	TERMS & CONDITION	VENDOR CONFIRMATION /REMARKS / REPLY
1	BIDDER NAME	
2	GEM BID NO	
3	ITEM IS TO BE SUPPLIED AS PER TECHNICAL SPECIFICATION	
4	ALL VENDORS TO PROVIDE POINT WISE REPLY/CONFIRMATION ALONG WITH RELEVANT SUPPORTING DOCUMENTS TO EACH AND EVERY POINT OF PRE-QUALIFICATION REQUIREMENT/PQR FOR ALL ENQUIRY ITEMS. NONCOMPLIANCE OF THESE MAY LEAD TO REJECTION OF OFFER AS THESE ARE ESSENTIAL CONDITION FOR PARTICIPATING IN TENDER ENQUIRY	
5	KINDLY UPLOAD/ATTACH THE SPECIFICATION DETAILS/ CATALOGUE OF OFFERED ITEMS.	
6	VENDOR TO CONFIRM TO PROVIDE MATERIAL & DIMENSIONAL TEST CERTIFICATES AS PER ENQUIRY DOCUMENTS ALONG WITH MATERIAL DISPATCH	
7	VENDOR TO CONFIRM TO PROVIDE DOCUMENTS KEEPING PROPER CORRELATION WITH PO ITEMS AND THEIR QUANTITY	
8	VENDOR TO CONFIRM TO PROVIDE CERTIFICATE OF CONFORMANCE ALONG WITH MATERIAL DISPATCH.	
9	VENDOR TO CONFIRM TO PROVIDE NON-REMOVABLE IDENTIFICATION OF ALL ITEMS AND THEIR REPORT ACCORDINGLY	
10	RISK PURCHASE: IN CASE OF ABNORMAL DELAYS (BEYOND THE MAXIMUM LATE DELIVERY PERIOD AS PER LD CLAUSE) IN SUPPLIES / DEFECTIVE SUPPLIES OR NONFULFILLMENT OF ANY OTHER TERMS AND CONDITIONS GIVEN IN PURCHASE ORDER, BHEL MAY CANCEL THE PURCHASE ORDER IN FULL OR PART THEREOF, AND MAY ALSO MAKE THE PURCHASE OF SUCH MATERIAL FROM ELSEWHERE / ALTERNATIVE SOURCE AT THE RISK AND COST OF THE SUPPLIER. BHEL WILL TAKE ALL REASONABLE STEPS TO GET THE MATERIAL FROM ALTERNATE SOURCE AT OPTIMUM COST. IF BIDDER DOES NOT AGREE TO THE ABOVE RISK PURCHASE CLAUSE, BHEL RESERVES THE RIGHT TO REJECT THE OFFER. IN CASE FOR COMPELLING REASONS BHEL ACCEPTS THE OFFER WITHOUT ACCEPTANCE OF THIS CLAUSE BY THE BIDDER AND IN THE EVENTUALITY OF RISK PURCHASE, APPROPRIATE ACTION WILL BE TAKEN AS PER BHEL EXTANT RULES. THIS WILL BE WITHOUT PREJUDICE TO ANY OTHER RIGHT OF BHEL UNDER THE CONTRACT OR UNDER GENERAL LAW.	
11	ACTION AGAINST BIDDERS / VENDOR / SUPPLIER / CONTRACTOR IN CASE OF DEFAULT: IN ORDER TO PROTECT THE COMMERCIAL INTERESTS OF BHEL, BHEL SHALL TAKE ACTION AGAINST SUPPLIES / CONTRACTORS BY WAY OF SUSPENSION OF BUSINESS DEALINGS, WHO EITHER FAIL TO PERFORM OR ARE IN DEFAULT WITHOUT ANY REASONABLE CAUSE, CAUSE LOSS OF BUSINESS/ MONEY/ REPUTATION, INDULGE IN MALPRACTICES, CHEATING, BRIBERY, FRAUD OR ANY OTHER MISCONDUCT OR FORMATION OF CARTELS SO AS TO INFLUENCE THE BIDDING PROCESS OR INFLUENCE THE PRICE ETC. SUSPENSION OF BUSINESS DEALINGS COULD BE IN THE FORM OF “HOLD” OR “BANNING” A SUPPLIER/ CONTRACTOR OR A BIDDER AND SHALL BE AS PER “GUIDELINES FOR SUSPENSION OF BUSINESS DEALINGS WITH SUPPLIERS/ CONTRACTORS” AVAILABLE AT BHEL’S WEBSITE “ https://www.bhel.com/guidelines-suspension-business-dealings-supplierscontractors ”	

1. ALL VENDORS TO PROVIDE POINT WISE REPLY/CONFIRMATION ALONG WITH RELEVANT SUPPORTING DOCUMENTS TO EACH AND EVERY POINT OF PRE-QUALIFICATION REQUIREMENT/PQR FOR ALL ENQUIRY ITEMS. NONCOMPLIANCE OF THESE MAY LEAD TO REJECTION OF OFFER AS THESE ARE ESSENTIAL CONDITION FOR PARTICIPATING IN TENDER ENQUIRY
2. KINDLY UPLOAD/ATTACH THE SPECIFICATION DETAILS/ CATALOGUE OF OFFERED ITEMS.
3. KINDLY ARRANGE TO **SUBMIT TECHNO-COMMERCIAL CHECKLIST** ALONG WITH YOUR OFFER.
4. VENDOR TO CONFIRM TO PROVIDE MATERIAL & DIMENSIONAL TEST CERTIFICATES AS PER ENQUIRY DOCUMENTS ALONG WITH MATERIAL DISPATCH.
5. VENDOR TO CONFIRM TO PROVIDE DOCUMENTS KEEPING PROPER CORRELATION WITH PO ITEMS AND THEIR QUANTITY.
6. VENDOR TO CONFIRM TO PROVIDE CERTIFICATE OF CONFORMANCE ALONG WITH MATERIAL DISPATCH.
7. VENDOR TO CONFIRM TO PROVIDE NON-REMOVABLE IDENTIFICATION OF ALL ITEMS AND THEIR REPORT ACCORDINGLY.
8. MSE/MII: THE SUPPLIER NEEDS TO SUBMIT/UPDATE MSE/MII CREDENTIALS ON GEM PORTAL DURING PROFILE UPDATION/ OFFER SUBMISSION STAGE. THE MSE DATA SUBMITTED IS CROSS VERIFIED BY GEM WITH GOVT. OF INDIA UDYAM/NSIC DATABASE THROUGH API INTEGRATION ON REAL TIME BASIS AND FOR MII, A SELF DECLARATION IS BEING GIVEN AND AUTHENTICATED BY AADHAR OTP. IF THE SELLER FAILS TO CLAIM MSE/MII PROVISION ON GEM PORTAL AT PROFILE UPDATION/BID SUBMISSION STAGE, THE SAID SELLER WILL BECOME INELIGIBLE FOR GETTING THE MSE/MII BENEFITS FOR THAT BID AUTOMATICALLY. THE VENDOR CAN ALWAYS CONTACT THE GEM HELPDESK, IN CASE OF ANY ISSUES.
9. THE PRICE QUOTE BY BIDDER SHOULD BE INCLUSIVE OF GST & SHOULD BE ON BHEL HEEP HARIDWAR STORES BASIS.
10. BIDDER'S OFFER IS LIABLE TO BE REJECTED IF THEY DON'T UPLOAD ANY OF THE CERTIFICATES / DOCUMENTS SOUGHT IN THE BID DOCUMENT, ATC AND CORRIGENDUM IF ANY.
11. **RISK PURCHASE:** IN CASE OF ABNORMAL DELAYS (BEYOND THE MAXIMUM LATE DELIVERY PERIOD AS PER LD CLAUSE) IN SUPPLIES / DEFECTIVE SUPPLIES OR NONFULFILLMENT OF ANY OTHER TERMS AND CONDITIONS GIVEN IN PURCHASE ORDER, BHEL MAY CANCEL THE PURCHASE ORDER IN FULL OR PART THEREOF, AND MAY ALSO MAKE THE PURCHASE OF SUCH MATERIAL FROM ELSEWHERE / ALTERNATIVE SOURCE AT THE RISK AND COST OF THE SUPPLIER. BHEL WILL TAKE ALL REASONABLE STEPS TO GET THE MATERIAL FROM ALTERNATE SOURCE AT OPTIMUM COST. IF BIDDER DOES NOT AGREE TO THE ABOVE RISK PURCHASE CLAUSE, BHEL RESERVES THE RIGHT TO REJECT THE OFFER. IN CASE FOR COMPELLING REASONS BHEL ACCEPTS THE OFFER WITHOUT ACCEPTANCE OF THIS CLAUSE BY THE BIDDER AND IN THE EVENTUALITY OF RISK PURCHASE, APPROPRIATE ACTION WILL BE TAKEN AS PER BHEL EXTANT RULES. THIS WILL BE WITHOUT PREJUDICE TO ANY OTHER RIGHT OF BHEL UNDER THE CONTRACT OR UNDER GENERAL LAW.
12. **ACTION AGAINST BIDDERS / VENDOR / SUPPLIER / CONTRACTOR IN CASE OF DEFAULT:**
IN ORDER TO PROTECT THE COMMERCIAL INTERESTS OF BHEL, BHEL SHALL TAKE ACTION AGAINST SUPPLIES / CONTRACTORS BY WAY OF SUSPENSION OF BUSINESS DEALINGS, WHO EITHER FAIL TO PERFORM OR ARE IN DEFAULT WITHOUT ANY REASONABLE CAUSE, CAUSE LOSS OF BUSINESS/ MONEY/ REPUTATION, INDULGE IN MALPRACTICES, CHEATING, BRIBERY, FRAUD OR ANY OTHER MISCONDUCT OR FORMATION OF CARTELS SO AS TO INFLUENCE THE BIDDING PROCESS OR INFLUENCE THE PRICE ETC.
SUSPENSION OF BUSINESS DEALINGS COULD BE IN THE FORM OF "HOLD" OR "BANNING" A SUPPLIER/ CONTRACTOR OR A BIDDER AND SHALL BE AS PER "GUIDELINES FOR SUSPENSION OF BUSINESS DEALINGS WITH SUPPLIERS/ CONTRACTORS" AVAILABLE AT BHEL'S WEBSITE <https://www.bhel.com/guidelines-suspension-business-dealings-supplierscontractors>

13. BIDDERS ARE ADVISED TO CHECK APPLICABLE GST ON THEIR OWN BEFORE QUOTING. BUYER WILL NOT TAKE ANY RESPONSIBILITY IN THIS REGARDS. GST REIMBURSEMENT WILL BE AS PER ACTUALS OR AS PER APPLICABLE RATES (WHICHEVER IS LOWER), SUBJECT TO THE MAXIMUM OF QUOTED GST %.

14. BIDDER SHALL SUBMIT THE FOLLOWING DOCUMENTS ALONG WITH THEIR BID FOR VENDOR CODE CREATION:
A. COPY OF PAN CARD B. COPY OF GSTIN C. COPY OF MSE CERIFICATE

15. DEDICATED /TOLL FREE TELEPHONE NO. FOR SERVICE SUPPORT: BIDDER/OEM MUST HAVE DEDICATED/TOLL FREE TELEPHONE NO. FOR SERVICE SUPPORT.

16. DATA SHEET OF THE PRODUCT(S) OFFERED IN THE BID, ARE TO BE UPLOADED ALONG WITH THE BID DOCUMENTS. BUYERS CAN MATCH AND VERIFY THE DATA SHEET WITH THE PRODUCT SPECIFICATIONS OFFERED. IN CASE OF ANY UNEXPLAINED MISMATCH OF TECHNICAL PARAMETERS, THE BID IS LIABLE FOR REJECTION.

17. SCOPE OF SUPPLY (BID PRICE TO INCLUDE ALL COST COMPONENTS): ONLY SUPPLY OF GOODS.

18. PRODUCTS SUPPLIED SHALL BE NONTOXIC AND HARMLESS TO HEALTH. IN THE CASE OF TOXIC MATERIALS, MATERIAL SAFETY DATA SHEET MAY BE FURNISHED ALONG WITH THE MATERIAL.

19. WHILE GENERATING INVOICE IN GEM PORTAL, THE SELLER MUST UPLOAD SCANNED COPY OF GST INVOICE AND THE SCREENSHOT OF GST PORTAL CONFIRMING PAYMENT OF GST.

20. PAYMENT TERMS SHALL BE AS PER FOLLOWINGS:

a) **For Non-MSME bidders:** 100% payment along with taxes, freight & insurance will be made after receipt and acceptance of material and within 90 days from the date of invoice subject to submission of non-discrepant documents within 15 days of supply as per terms and conditions of Purchase Order. (MSME means Micro, Small & Medium Enterprises) (THIS IS IN SUPERSESSION OF 10 DAYS' TIME AS PROVIDED IN CLAUSE 12 OF GEM GTC).

b) **FOR MSE BIDDER:** For MSEs (covered under MSME Act) which are registered and periodically renewed with BHEL, the payment will be made within 45 days or as prescribed in the relevant act. Benefits of MSE (such as EMD Waiver, Tender fee exemption, Price preference, Payment preference etc.) will be given only to those MSE Vendors who are manufacturers of offered items against the NIT. No MSE benefits shall be provided to Agents / Stockists /Dealers / Traders etc. for the items offered but not manufactured by themselves.”

c) **FOR MEDIUM ENTERPRISES:** 100% payment along with taxes, freight & insurance will be made after receipt and acceptance of material and within 60 days from the date of invoice subject to submission of non-discrepant documents within 15 days of supply as per terms and conditions of Purchase Order.

d) Please note that vendor to adhere to the payment terms as per above. No deviation in payment terms shall be accepted. Vendor to submit their offer accordingly.