



**REQUIREMENT OF BUSH FORGING; BRONZO TENAX K**

The Heavy Electricals Equipment Plant (HEEP) located in Haridwar, India is one of the major manufacturing plants of Bharat Heavy Electricals Ltd. The core business of HEEP includes design and manufacture of large steam and gas turbines, turbo generators, Defense Items and so on.

Details of items as below:

SI. NO.	MAT CODE	ITEM DISCREPTION	LOT NO.	Quantity (NOS.)	The Delivery Schedule
1	W93078299090	BUSH FORGING (FORGING WITH MATERIAL AS PER BHEL PLANT SPECIFICATION AA12142 ALSO ACCEPTABLE SIZE: P/N 127699200 GRADE: BRONZO TENAX K	1 <sup>st</sup>	20	OCT 2024
			2 <sup>nd</sup>	20	OCT 2025
			3 <sup>rd</sup>	12	OCT 2026

**SPECIAL INSTRUCTIONS:**

1. ALL VENDORS TO PROVIDE POINT WISE REPLY/CONFIRMATION ALONG WITH RELEVANT SUPPORTING DOCUMENTS TO EACH AND EVERY POINT OF **PRE-QUALIFICATION REQUIREMENT/PQR** FOR ALL ENQUIRY ITEMS. NONCOMPLIANCE OF THESE MAY LEAD TO REJECTION OF OFFER AS THESE ARE ESSENTIAL CONDITION FOR PARTICIPATING IN TENDER ENQUIRY.
2. KINDLY UPLOAD/ATTACH THE SPECIFICATION DETAILS/ CATALOGUE OF OFFERED ITEMS.
3. KINDLY ARRANGE TO SUBMIT TECHNO-COMMERCIAL CHECKLIST ALONG WITH YOUR OFFER.
4. VENDOR TO CONFIRM TO PROVIDE MATERIAL (CHEMICAL AND MECHANICAL PROPERTIES) AND DIMENSIONAL TEST CERTIFICATES OF BUSH FORGING AS PER ENQUIRY CHECKLIST AND SPECIFICATION ALONG WITH SUPPLY.
5. VENDOR TO PROVIDE CERTIFICATE OF CONFORMANCE ALONG WITH MATERIAL DISPATCH.
6. VENDOR TO CONFIRM TO PROVIDE CO-RELATION OF ALL TEST CERTIFICATES AS PER SPECIFICATION.
7. VENDOR TO PROVIDE NON-REMOVABLE IDENTIFICATION OF ALL ITEMS AND THEIR REPORT ACCORDINGLY.
8. EARLY DELIVERY ACCEPTABLE FOR LOT 1.
9. LOT 2 - EARLY DELIVERY ACCEPTABLE AUGUST 2025 ONWARDS.
10. LOT 3 - EARLY DELIVERY ACCEPTABLE AUGUST 2026 ONWARDS.

**QUALIFYING CONDITIONS FOR BUSH FORGING.**

<b>Sl.</b>	<b>PQR Requirement</b>	<b>Action</b>	<b>Vendor Response (Yes / No / Enclosed)</b>
1.	who can manufacture or supply FORGINGS as per BHEL drawing & specification AA12142	Vendor to specify	
2.	who has read and understood the requirement of BHEL forging drawing & specification AA2142	Vendor to confirm	

**TECHNICAL PARAMETERS CHECK LIST**  
**DATA VALUES TO BE FILLED AND CONFIRMED BY VENDOR**

ITEM CODE                    W93078299090  
ITEM NAME:                    BUSH FORGING  
ITEM PART NO:                127699200  
Internation Equivalent:    AA12142

**NOTE:** Vendor to input parameters based on the specification of the quoted item.

SN.	PARAMETERS	VALUES	UNIT	RESPONSE TYPE	VENDOR RESPONSE
1	MATERIAL CODES	W93078299090	NO	To confirm →	
2	STANDARD	AS PER DRAWING OR SPEC-AA12142	-	To confirm →	
3	GRADE/MATERIAL	AS PER DRAWING OR SPEC-AA12142	-	To confirm →	
4	SUPPLY CONDITION	AS PER DRAWING OR SPEC-AA12142	-	To confirm →	
5	SHAPE/SIZE	AS PER DRAWING	-	To confirm →	
6	CERTIFICATION	AS PER DRAWING OR SPEC-AA12142	Y	confirm to supply →	
7	VENDOR REMARKS (Deviation if any)				

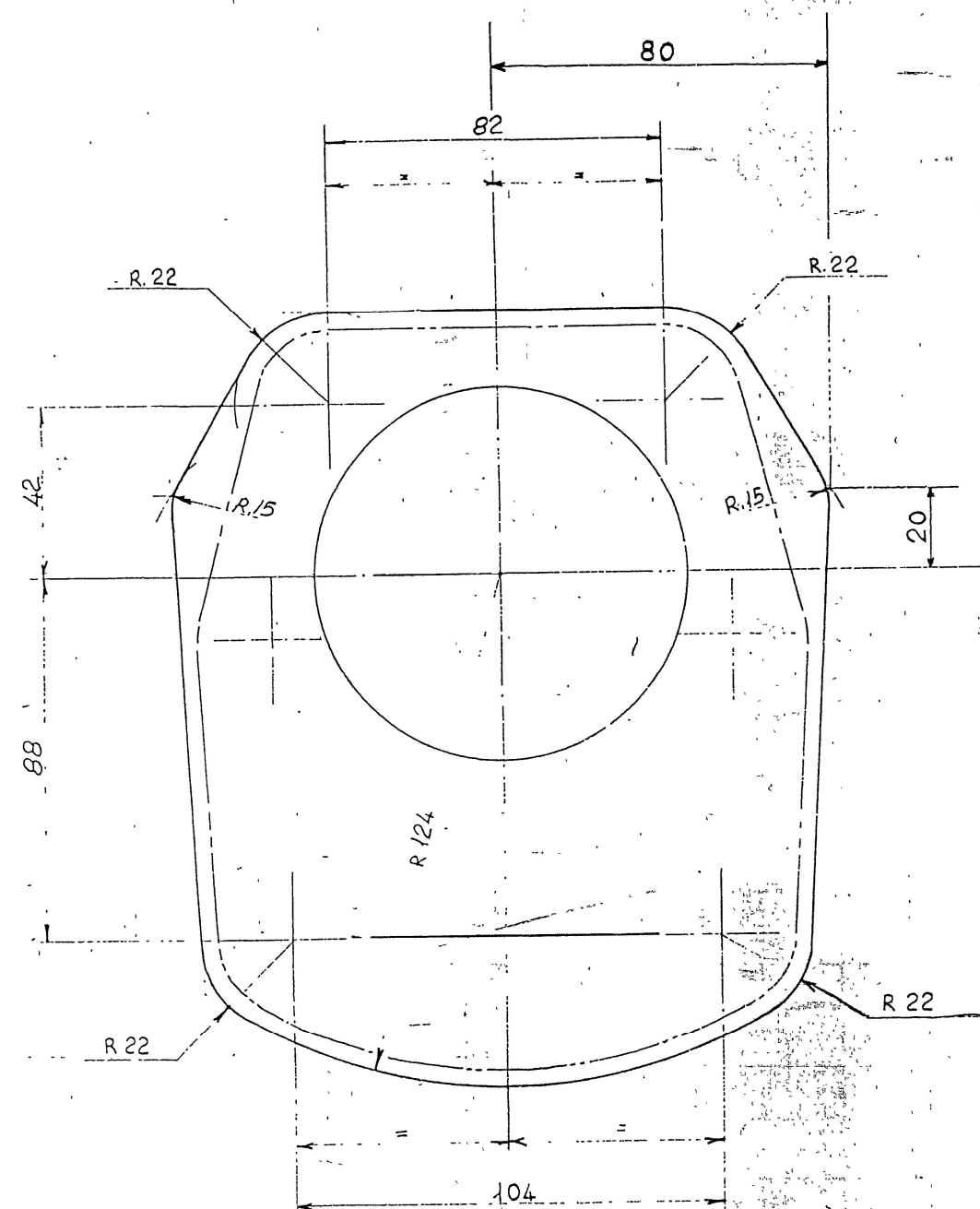

QUESTO DISEGNO VALE SOLO PER I SOPRAMETALLI  
 LE QUOTE E GLI SFORMI VERRANNO STABILITI DAL  
 FORNITORE CONSULTANDO QUELLI DEL DISEGNO FINITO  
 1276-08-188-00

FORGING FOR DWG  
 STAMPATO PER DISEGNO 1276-08-188

Boccola		2	BRONZO TENAX-K			STAMP.	
N. Parti Cotture	DENOMINAZIONE	N. Parti per Serie	MATERIALE	Stivato Finito	RICAVATO DA	NORMALE	NOTE
1	1276-08-188-00	1	Modificata quota da 12 a 14				
2							
3							
4							
5							
6							
7							
8							

Titolo: COSTA COMPACT  
 BOCCOLA STAMPATA  
 SOCIETA PER AZIONI  
 OTO-MELARA  
 LA SPEZIA  
 Disegnata: VISTO  
 Data: 22-5-67  
 Scale: 1:1  
 Det. n.: 1276-99-200-01-00

THIS IS A REFERENCE DRAWING

VERIFY WITH FINISHED PART DWG 1276-08-188

PROPRIETARY DATA  
 LIMITED AMOUNT OF TECHNICAL DATA  
 TECHNICAL DATA SET FORTH HEREIN IS  
 SUBJECT TO THE TERMS AND CONDITIONS OF  
 A LICENSE AGREEMENT SIGNED ON  
 19th MAY 1991 BETWEEN BHAPAT HEAVY  
 ELECTRICALS LIMITED, INDIA AND OTO MELARA  
 A SPEZIA, ITALY TO THE EXTENT APPLICABLE.  
 THE TECHNICAL DATA CONTAINED  
 HEREIN IS RESTRICTED AS TO USE, REPRODUCTION  
 OR DISCLOSURE AS PER TERMS AND  
 CONDITIONS OF THE SAID AGREEMENT

BRONZE TENAX K

PART NUMBER	DESCRIPTIONS	QTY	MATERIAL SPEC	MADE FROM	STANDARD CODIFICATION
	BUSH	2		FORGING	

TITLE: FORGED BUSH  
 GENERAL TOLERANCES:  
 LINEAR DIMENSIONS UP TO 100: ±0.1  
 > 100 TO 300: ±0.15  
 > 300 TO 1000: ±0.2  
 > 1000 TO 3000: ±0.3  
 > 3000 TO 10000: ±0.5  
 ANGLES: 1:30  
 CASTING TOLERANCES:  
 LINEAR DIMENSIONS (0.1 < x < 100 mm): ±0.15  
 THICKNESS: ±0.1 (min 1.0 mm)  
 ANGLES: 1:3  
 FORGING TOLERANCES:  
 LINEAR DIMENSIONS UP TO 100: ±0.1  
 LINEAR DIMENSIONS UP TO 1000: ±0.2  
 > 1000 TO 3000: ±0.3  
 > 3000 TO 10000: ±0.5  
 SURFACES:  
 REQUIRE TO BE REMOVED: ±0.1

## TECHNO-COMMERCIAL CHECKLIST

SL. NO.	TERMS & CONDITION	VENDOR CONFIRMATION /REMARKS / REPLY
<b>TENDER DETAILS</b>		
1	BIDDER NAME	
2	GEM BID NO	
<b>QUALITY &amp; TECHNICAL REQUIREMENTS</b>		
3	VENDOR TO CONFIRM TO PROVIDE MATERIAL (CHEMICAL AND MECHANICAL PROPERTIES) AND DIMENSIONAL TEST CERTIFICATES OF BUSH FORGING AS PER ENQUIRY CHECKLIST AND SPECIFICATION ALONG WITH SUPPLY	
4	VENDOR TO CONFIRM TO PROVIDE CERTIFICATE OF CONFORMANCE ALONG WITH MATERIAL DISPATCH.	
5	VENDOR TO CONFIRM TO PROVIDE CO-RELATION OF ALL TEST CERTIFICATES AS PER SPECIFICATION	
6	VENDOR TO PROVIDE NON-REMOVABLE IDENTIFICATION OF ALL ITEMS AND THEIR REPORT ACCORDINGLY	
<b>COMMERICAL REMARKS</b>		
7	ITEM IS TO BE SUPPLIED AS PER TECHNICAL SPECIFICATION /DRAWING/STANDARDS	
8	KINDLY UPLOAD/ATTACH THE SPECIFICATION DETAILS/ CATALOGUE OF OFFERED ITEMS.	
9	VENDOR TO CONFIRM THAT DELIVERY SHALL BE IN STAGGERED MANNER AS PER BELOW LOT WISE: LOT 1: OCT 2024 LOT 2: OCT 2025 LOT 3: OCT 2026	
10	KINDLY SUBMIT MAKE IN INDIA CERTIFICATE	
11	<p><b>RISK PURCHASE:</b> IN CASE OF ABNORMAL DELAYS (BEYOND THE MAXIMUM LATE DELIVERY PERIOD AS PER LD CLAUSE) IN SUPPLIES / DEFECTIVE SUPPLIES OR NONFULFILLMENT OF ANY OTHER TERMS AND CONDITIONS GIVEN IN PURCHASE ORDER, BHEL MAY CANCEL THE PURCHASE ORDER IN FULL OR PART THEREOF, AND MAY ALSO MAKE THE PURCHASE OF SUCH MATERIAL FROM ELSEWHERE / ALTERNATIVE SOURCE AT THE RISK AND COST OF THE SUPPLIER. BHEL WILL TAKE ALL REASONABLE STEPS TO GET THE MATERIAL FROM ALTERNATE SOURCE AT OPTIMUM COST. IF BIDDER DOES NOT AGREE TO THE ABOVE RISK PURCHASE CLAUSE, BHEL RESERVES THE RIGHT TO REJECT THE OFFER. IN CASE FOR COMPELLING REASONS BHEL ACCEPTS THE OFFER WITHOUT ACCEPTANCE OF THIS CLAUSE BY THE BIDDER AND IN THE EVENTUALITY OF RISK PURCHASE, APPROPRIATE ACTION WILL BE TAKEN AS PER BHEL EXTANT RULES. THIS WILL BE WITHOUT PREJUDICE TO ANY OTHER RIGHT OF BHEL UNDER THE CONTRACT OR UNDER GENERAL LAW.</p> <p>IN CASE OF BREACH OF CONTRACT, WHEREVER THE VALUE OF SECURITY INSTRUMENTS LIKE PERFORMANCE BANK GUARANTEE AVAILABLE WITH BHEL AGAINST THE SAID CONTRACT IS ATLEAST 10% OF THE CONTRACT VALUE, THE SAME BE ENCASHED. IN CASE THE VALUE OF THE SECURITY INSTRUMENTS AVAILABLE IS LESS THAN 10% OF THE CONTRACT VALUE, THE BALANCE AMOUNT BE RECOVERED FROM OTHER FINANCIAL REMEDIES (I.E. AVAILABLE BILLS OF THE CONTRACTOR, RETENTION AMOUNT, ETC. WITH BHEL) OR LEGAL REMEDIES BE PURSUED.</p>	
12	<p><b>ACTION AGAINST BIDDERS / VENDOR / SUPPLIER / CONTRACTOR IN CASE OF DEFAULT:</b> IN ORDER TO PROTECT THE COMMERCIAL INTERESTS OF BHEL, BHEL SHALL TAKE ACTION AGAINST SUPPLIES / CONTRACTORS BY WAY OF SUSPENSION OF BUSINESS DEALINGS, WHO EITHER FAIL TO PERFORM OR ARE IN DEFAULT WITHOUT ANY REASONABLE CAUSE, CAUSE LOSS OF BUSINESS/ MONEY/ REPUTATION, INDULGE IN MALPRACTICES, CHEATING, BRIBERY, FRAUD OR ANY OTHER MISCONDUCT OR FORMATION OF CARTELS SO AS TO INFLUENCE THE BIDDING PROCESS OR INFLUENCE THE PRICE ETC.</p> <p>SUSPENSION OF BUSINESS DEALINGS COULD BE IN THE FORM OF "HOLD" OR "BANNING" A SUPPLIER/ CONTRACTOR OR A BIDDER AND SHALL BE AS PER "GUIDELINES FOR SUSPENSION OF BUSINESS DEALINGS WITH SUPPLIERS/ CONTRACTORS" AVAILABLE AT BHEL'S WEBSITE "<a href="https://www.bhel.com/guidelines-suspension-business-dealings-supplierscontractors">https://www.bhel.com/guidelines-suspension-business-dealings-supplierscontractors</a>"</p>	
13	REST GENERAL TERMS AND CONDITIONS AS PER GeM	



# CORPORATE PURCHASING SPECIFICATION

AA12142

Rev No.04

PREFACE SHEET

## 10% ALUMINIUM BRONZE RODS

FOR INTERNAL USE ONLY

REMOVE THIS PREFACE BEFORE ISSUE TO SUPPLIERS

### Equivalent/Comparable Standards

- |             |   |                                    |
|-------------|---|------------------------------------|
| 1) INDIAN   | : | IS: 10569-2005<br>Gr: CuAl10Fe5Ni5 |
| 2) AMERICAN | : | ASTM B150-2013                     |
| 3) BRITISH  | : | BS EN 12163-2011                   |

### Suggested/Probable Suppliers and Grades:

Refer plant vendors list

### User Plants and Replaced Plant Specifications/References:

- |              |   |            |
|--------------|---|------------|
| 1. BHOPAL    | : | P.S. 12019 |
| 2. HYDERABAD | : | 0502. 206  |

Revisions:  
As per clause 26.5.3 of MOM of MRC-  
NFM+HE

**APPROVED:**  
INTERPLANT MATERIAL RATIONALISATION  
COMMITTEE – MRC(NFM+HE)

Rev No.04	Amd No.	Reaffirmed	Prepared	Issued	Dt. of 1 <sup>st</sup> Issue
Dt:22-08-2014	Dt:	Year:	HEEP, Haridwar	Corp.R&D	01-04-1978



# CORPORATE PURCHASING SPECIFICATION

AA12142

Rev No.04

PAGE 1 of 3

## 10% ALUMINIUM BRONZE RODS

### 1.0 GENERAL

This specification governs the quality of 10% Aluminium Bronze Rods.

### 2.0 APPLICATION

For general engineering purposes.

### 3.0 CONDITION OF DELIVERY

Extruded / Rolled / Forged.

The ends shall be cut square with the axis of the rod.

### 4.0 COMPLIANCE WITH NATIONAL STANDARDS

The material shall comply with the requirements of the following national standard and also meet the requirements of this specification.

IS: 10569 – 2005: ALUMINIUM BRONZE RODS, BARS AND SECTIONS

Grade: CuAl10Fe5Ni5

### 5.0 DIMENSIONS AND TOLERANCES

5.1 **Sizes:** The material shall be supplied as per the dimensions specified in the order.

5.2 **Tolerances:** The tolerance on sizes of bars/rods shall be as per IS: 2826

### 6.0 FREEDOM FROM DEFECTS

The material shall be clean, smooth and free fins, spills, porosity, cracks or other defects and shall be reasonably straight and free from twists.

### 7.0 CHEMICAL COMPOSITION

The chemical composition of the material when analyzed in accordance with IS: 4027 (Method for chemical analysis of bronzes) or any other established instrumental/chemical method shall conform following:

Aluminium	Iron	Nickel	Manganese	Copper	Tin	Lead
8.5 – 11.0	4.0 – 6.0	4.0 – 6.0	≤ 0.50	Remainder	≤ 0.10	≤ 0.05

Zinc	Silicon	Magnesium	Total Impurities
≤ 0.40	≤ 0.10	≤ 0.05	≤ 0.50 (excluding Manganese)

Revisions:  
As per clause 26.5.3 of MOM of MRC-NFM+HE

**APPROVED:**  
INTERPLANT MATERIAL RATIONALISATION  
COMMITTEE – MRC(NFM+HE)

Rev No.04	Amd No.	Reaffirmed	Prepared	Issued	Dt. of 1 <sup>st</sup> Issue
Dt:22-08-2014	Dt:	Year:	HEEP, Haridwar	Corp.R&D	01-04-1978

COPYRIGHT AND CONFIDENTIAL  
The Information on this document is the property of BHARAT HEAVY ELECTRICALS LIMITED.  
It must not be used directly or indirectly in any way detrimental to the Interest of the company.

CS-1005  
22/08/14

AA12142

Rev No.04

PAGE 2 of 3

# CORPORATE PURCHASING SPECIFICATION



## 8.0 TEST SAMPLES

8.1 One sample per heat shall be taken for chemical analysis.

### 8.2 For Mechanical Properties

The material shall be grouped in batches as given below and one sample shall be selected from each batch or remaining part of a batch to provide the necessary test pieces.

Size (Diameter or width across flats, mm)		Weight of batch, kg
Over	Up to & incl.	
-	12	250
12	40	500
40	-	1000

8.3 The tensile test shall be made on test pieces machined to shape and largest dimensions practicable as specified in IS: 1608

8.4 Up to and including 32 mm rods, the central longitudinal axis of test pieces shall be the same as that of rods.

8.5 In case of rods over 32 mm, the central longitudinal axis of the test piece shall be at least 16 mm from the nearest face/surface.

8.6 The fractured test piece shall be free from pipe and other surface defects.

8.7 If the tensile test piece break outside the middle third of the gauge length and the elongation percentage obtained be lower than minimum specified, the test may be discarded and another test made.

## 9.0 MECHANICAL PROPERTIES

### 9.1 Tensile Test

The material when tested in accordance with IS: 1608 shall meet the following properties.

Size (in mm)		Tensile Strength N/mm <sup>2</sup>	0.2% Proof Stress N/mm <sup>2</sup>	% Elongation on 5.65√So Gauge length
Over	Up to & including			
6	15	≥ 700	≥ 400	≥ 10
15	50	≥ 700	≥ 400	≥ 12
50	80	≥ 680	≥ 350	≥ 12
80 and above		≥ 650	≥ 320	≥ 12

## 10.0 RETEST

If any of the test pieces first selected fail to pass any of the prescribed tests, two further samples from the same batch shall be selected for testing, one of which shall be from the same piece of material from which the original test sample was taken, unless it is withdrawn by the supplier.

If the test pieces from both this additional samples pass, the batch represented by the test sample shall be accepted. If the test pieces from either of these additional samples fail, the batch represented by the test samples shall be rejected.

41/8/20

5001-50



# CORPORATE PURCHASING SPECIFICATION

AA12142

Rev No.04

PAGE 3 of 3

## 11.0 INSPECTION AT SUPPLIER'S WORKS

Tests and inspection are to be conducted in the presence of the customer's representative. The representative shall have free access at all times while the work on the contract is being performed, to all parts of the manufacture's works. The supplier shall offer the purchaser's representative all reasonable facilities, without charge, to satisfy the latter that the material is being furnished in accordance with this specification. The supplier shall prepare and provide necessary test specimens for testing to be carried out at his premises. If facilities are not available at his works, the supplier shall make necessary arrangement for carrying out the prescribed test elsewhere.

## 12.0 TEST CERTIFICATES

The supplier shall submit 3 copies of test certificates giving the following information:

In addition, the supplier shall ensure to enclose one copy of the test certificate along with the dispatch documents to facilitate quick clearance of the material.

BHEL Order No.

AA12142, Rev-04: 10% ALUMINIUM BRONZE RODS

Supplier's Reference and Name

Batch No.

Consignment/Identification No.

Results of chemical analysis, mechanical and all other tests as called for in this specification/ order.

Consignment/Identification No.

## 13.0 PACKING AND MARKING

The material shall be suitably packed to prevent corrosion and damage during transit. Machined surfaces shall be properly protected with anti-corrosive compounds.

Each package shall be legibly marked with the following information:

BHEL Order No.

AA12142

Batch No.

Identification mark /No.

Weight

Supplier's Reference and Name

## 14.0 REFERRED STANDARDS (Latest Publications including Amendments)

1) IS: 2826

2) IS: 4027

3) IS: 1608

27/8/14

500-50

1. ALL VENDORS TO PROVIDE POINT WISE REPLY/CONFIRMATION ALONG WITH RELEVANT SUPPORTING DOCUMENTS TO EACH AND EVERY POINT OF **PRE-QUALIFICATION REQUIREMENT/PQR** FOR ALL ENQUIRY ITEMS. NONCOMPLIANCE OF THESE MAY LEAD TO REJECTION OF OFFER AS THESE ARE ESSENTIAL CONDITION FOR PARTICIPATING IN TENDER ENQUIRY.
2. KINDLY UPLOAD/ATTACH THE SPECIFICATION DETAILS/ CATALOGUE OF OFFERED ITEMS.
3. KINDLY ARRANGE TO **SUBMIT TECHNO-COMMERCIAL CHECKLIST** ALONG WITH YOUR OFFER.
4. VENDOR TO PROVIDE MATERIAL (CHEMICAL AND MECHANICAL PROPERTIES) AND DIMENSIONAL TEST CERTIFICATES OF BUSH FORGING AS PER ENQUIRY CHECKLIST AND SPECIFICATION ALONG WITH SUPPLY.
5. VENDOR TO PROVIDE CERTIFICATE OF CONFORMANCE ALONG WITH MATERIAL DISPATCH.
6. VENDOR TO PROVIDE CO-RELATION OF ALL TEST CERTIFICATES AS PER SPECIFICATION.
7. VENDOR TO PROVIDE NON-REMOVABLE IDENTIFICATION OF ALL ITEMS AND THEIR REPORT ACCORDINGLY.
8. DELIVERY SHALL BE IN STAGGERED MANNER AS PER BELOW TABLE:

SI. NO.	MAT CODE	ITEM DISCREPTION	LOT NO.	Quantity (NOS.)	The Delivery Schedule
1	W93078299090	BUSH FORGING (FORGING WITH MATERIAL AS PER BHEL PLANT SPECIFICATION AA12142 ALSO ACCEPTABLE SIZE: P/N 127699200 GRADE: BRONZO TENAX K	1 <sup>st</sup>	20	OCT 2024
			2 <sup>nd</sup>	20	OCT 2025
			3 <sup>rd</sup>	12	OCT 2026
2	W93078299120	BUSH FORGING (FORGING WITH MATERIAL AS PER BHEL PLANT SPECIFICATION AA12142 ALSO ACCEPTABLE SIZE: P/N 127699192 GRADE: BRONZO TENAX K	1 <sup>st</sup>	20	OCT 2024
			2 <sup>nd</sup>	20	OCT 2025
			3 <sup>rd</sup>	14	OCT 2026

9. EARLY DELIVERY ACCEPTABLE FOR LOT 1.
10. LOT 2 - EARLY DELIVERY ACCEPTABLE AUGUST 2025 ONWARDS.
11. LOT 3 - EARLY DELIVERY ACCEPTABLE AUGUST 2026 ONWARDS.
12. KINDLY SUBMIT MAKE IN INDIA CERTIFICATE.
13. MSE/MII: THE SUPPLIER NEEDS TO SUBMIT/UPDATE MSE/MII CREDENTIALS ON GEM PORTAL DURING PROFILE UPDATION/ OFFER SUBMISSION STAGE. THE MSE DATA SUBMITTED IS CROSS VERIFIED BY GEM WITH GOVT. OF INDIA UDYAM/NSIC DATABASE THROUGH API INTEGRATION ON REAL TIME BASIS AND FOR MII, A SELF DECLARATION IS BEING GIVEN AND AUTHENTICATED BY AADHAR OTP. IF THE SELLER FAILS TO CLAIM MSE/MII PROVISION ON GEM PORTAL AT PROFILE UPDATION/BID SUBMISSION STAGE, THE SAID SELLER WILL BECOME INELIGIBLE FOR GETTING THE MSE/MII BENEFITS FOR THAT BID AUTOMATICALLY. THE VENDOR CAN ALWAYS CONTACT THE GEM HELPDESK, IN CASE OF ANY ISSUES.
14. THE PRICE QUOTE BY BIDDER SHOULD BE INCLUSIVE OF GST & SHOULD BE ON BHEL HEEP HARIDWAR STORES BASIS.

15. BIDDER'S OFFER IS LIABLE TO BE REJECTED IF THEY DON'T UPLOAD ANY OF THE CERTIFICATES / DOCUMENTS SOUGHT IN THE BID DOCUMENT, ATC AND CORRIGENDUM IF ANY.

**16. RISK PURCHASE:**

IN CASE OF ABNORMAL DELAYS (BEYOND THE MAXIMUM LATE DELIVERY PERIOD AS PER LD CLAUSE) IN SUPPLIES / DEFECTIVE SUPPLIES OR NONFULFILLMENT OF ANY OTHER TERMS AND CONDITIONS GIVEN IN PURCHASE ORDER, BHEL MAY CANCEL THE PURCHASE ORDER IN FULL OR PART THEREOF, AND MAY ALSO MAKE THE PURCHASE OF SUCH MATERIAL FROM ELSEWHERE / ALTERNATIVE SOURCE AT THE RISK AND COST OF THE SUPPLIER. BHEL WILL TAKE ALL REASONABLE STEPS TO GET THE MATERIAL FROM ALTERNATE SOURCE AT OPTIMUM COST. IF BIDDER DOES NOT AGREE TO THE ABOVE RISK PURCHASE CLAUSE, BHEL RESERVES THE RIGHT TO REJECT THE OFFER. IN CASE FOR COMPELLING REASONS BHEL ACCEPTS THE OFFER WITHOUT ACCEPTANCE OF THIS CLAUSE BY THE BIDDER AND IN THE EVENTUALITY OF RISK PURCHASE, APPROPRIATE ACTION WILL BE TAKEN AS PER BHEL EXTANT RULES. THIS WILL BE WITHOUT PREJUDICE TO ANY OTHER RIGHT OF BHEL UNDER THE CONTRACT OR UNDER GENERAL LAW.

IN CASE OF BREACH OF CONTRACT, WHEREVER THE VALUE OF SECURITY INSTRUMENTS LIKE PERFORMANCE BANK GUARANTEE AVAILABLE WITH BHEL AGAINST THE SAID CONTRACT IS ATLEAST 10% OF THE CONTRACT VALUE, THE SAME BE ENCASHED. IN CASE THE VALUE OF THE SECURITY INSTRUMENTS AVAILABLE IS LESS THAN 10% OF THE CONTRACT VALUE, THE BALANCE AMOUNT BE RECOVERED FROM OTHER FINANCIAL REMEDIES (I.E. AVAILABLE BILLS OF THE CONTRACTOR, RETENTION AMOUNT, ETC. WITH BHEL) OR LEGAL REMEDIES BE PURSUED.

**17. ACTION AGAINST BIDDERS / VENDOR / SUPPLIER / CONTRACTOR IN CASE OF DEFAULT:**

IN ORDER TO PROTECT THE COMMERCIAL INTERESTS OF BHEL, BHEL SHALL TAKE ACTION AGAINST SUPPLIES / CONTRACTORS BY WAY OF SUSPENSION OF BUSINESS DEALINGS, WHO EITHER FAIL TO PERFORM OR ARE IN DEFAULT WITHOUT ANY REASONABLE CAUSE, CAUSE LOSS OF BUSINESS/ MONEY/ REPUTATION, INDULGE IN MALPRACTICES, CHEATING, BRIBERY, FRAUD OR ANY OTHER MISCONDUCT OR FORMATION OF CARTELS SO AS TO INFLUENCE THE BIDDING PROCESS OR INFLUENCE THE PRICE ETC.

SUSPENSION OF BUSINESS DEALINGS COULD BE IN THE FORM OF "HOLD" OR "BANNING" A SUPPLIER/ CONTRACTOR OR A BIDDER AND SHALL BE AS PER "GUIDELINES FOR SUSPENSION OF BUSINESS DEALINGS WITH SUPPLIERS/ CONTRACTORS" AVAILABLE AT BHEL'S WEBSITE <https://www.bhel.com/guidelines-suspension-business-dealings-supplierscontractors>

18. BIDDERS ARE ADVISED TO CHECK APPLICABLE GST ON THEIR OWN BEFORE QUOTING. BUYER WILL NOT TAKE ANY RESPONSIBILITY IN THIS REGARDS. GST REIMBURSEMENT WILL BE AS PER ACTUALS OR AS PER APPLICABLE RATES (WHICHEVER IS LOWER), SUBJECT TO THE MAXIMUM OF QUOTED GST %.

19. BIDDER SHALL SUBMIT THE FOLLOWING DOCUMENTS ALONG WITH THEIR BID FOR VENDOR CODE CREATION:

**A. COPY OF PAN CARD B. COPY OF GSTIN C. COPY OF MSE CERIFICATE**

20. DEDICATED /TOLL FREE TELEPHONE NO. FOR SERVICE SUPPORT: BIDDER/OEM MUST HAVE DEDICATED/TOLL FREE TELEPHONE NO. FOR SERVICE SUPPORT.

21. DATA SHEET OF THE PRODUCT(S) OFFERED IN THE BID, ARE TO BE UPLOADED ALONG WITH THE BID DOCUMENTS. BUYERS CAN MATCH AND VERIFY THE DATA SHEET WITH THE PRODUCT SPECIFICATIONS OFFERED. IN CASE OF ANY UNEXPLAINED MISMATCH OF TECHNICAL PARAMETERS, THE BID IS LIABLE FOR REJECTION.

22. SCOPE OF SUPPLY (BID PRICE TO INCLUDE ALL COST COMPONENTS): ONLY SUPPLY OF GOODS.

23. PRODUCTS SUPPLIED SHALL BE NONTOXIC AND HARMLESS TO HEALTH. IN THE CASE OF TOXIC MATERIALS, MATERIAL SAFETY DATA SHEET MAY BE FURNISHED ALONG WITH THE MATERIAL.

24. WHILE GENERATING INVOICE IN GEM PORTAL, THE SELLER MUST UPLOAD SCANNED COPY OF GST INVOICE AND THE SCREENSHOT OF GST PORTAL CONFIRMING PAYMENT OF GST.

**25. PAYMENT TERMS SHALL BE AS PER FOLLOWINGS:**

- a) **FOR NON-MSES BIDDER:** 100% payment along with taxes, freight & insurance will be made after receipt and acceptance of material and within 90 days from the date of invoice subject to submission of non-discrepant documents within 15 days of supply as per terms and conditions of Purchase Order (THIS IS IN SUPERSESSION OF 10 DAYS' TIME AS PROVIDED IN CLAUSE 12 OF GEM GTC).
  
- b) **FOR MSES BIDDER:** For MSEs (covered under MSME Act) which are registered and periodically renewed with BHEL, the payment will be made within 45 days or as prescribed in the relevant act. Benefits of MSE (such as EMD Waiver, Tender fee exemption, Price preference, Payment preference etc.) will be given only to those MSE Vendors who are manufacturers of offered items against the NIT. No MSE benefits shall be provided to Agents / Stockists /Dealers / Traders etc. for the items offered but not manufactured by themselves.”
  
- c) **FOR MEDIUM ENTERPRISES:** 100% payment along with taxes, freight & insurance will be made after receipt and acceptance of material and within 60 days from the date of invoice subject to submission of non-discrepant documents within 15 days of supply as per terms and conditions of Purchase Order.
  
- d) Please note that vendor to adhere to the payment terms as per above. No deviation in payment terms shall be accepted. Vendor to submit their offer accordingly.