



An ISO 9001
Company

Bharat Heavy Electricals Limited

High Pressure Boiler Plant

Tiruchirappalli – 620014, TAMIL NADU, INDIA

Works Contracts Management Dept.

| | |
|--|--|
| ENQUIRY – Corrigendum-1 Dt.02.12.2023 | Phone: +91 431 257 1519 / 8187 Email : umashankarm@bhel.in Web : www.bhel.com |
|--|--|

| Web hosting ref no. | Enquiry Number & Date | Previous Corrigendum | Date for submission of quotation |
|-----------------------------------|--|----------------------|----------------------------------|
| <u>BHEL Website:</u> NIT_78436 | GeM Bid No. GEM/2023/B/4211114, dt. 23.11.2023 | NIL | 04.12.2023 |

Details of Corrigendum

| SL | NIT Page / Clause | Existing Clause | Revised Clause |
|----|-------------------------------|--|--|
| 1 | Tender Due Date Page 1 | Last date of receipt of filled in Tender / Offer 02.00 p.m. on 04.12.2023 Date & Time of opening of techno-commercial bid (Part-I) 02.30 p.m. on 04.12.2023 | Last date of receipt of filled in Tender / Offer 02.00 p.m. on 11.12.2023 Date & Time of opening of techno-commercial bid (Part-I) 02.30 p.m. on 11.12.2023 |
| 2 | Page 45 / Item SL 20 Point 1) | 3 KL , 17 kg/cm2(g) vacuum insulated liquid oxygen cryogenic storage tank with their accessories - 1 No. | 13 KL , 17 kg/cm2(g) vacuum insulated liquid oxygen cryogenic storage tank with their accessories - 1 No. |

All other tender terms & conditions remain unaltered. This corrigendum-1 is the integral part of the Tender. Hence the Tenderers are requested to Sign & Seal this Corrigendum-1 and enclose along with the Techno Commercial Bid in the e-Procurement Portal.

Tenders should be submitted in GeM Portal on or before 02:00 P.M. on the due date. Tenders will be opened at 02:30 P.M on the due date. Tenders would be opened in in the GeM Portal

Yours faithfully,
For BHARAT HEAVY ELECTRICALS LIMITED , TRICHY
ANJANA PACHORI
Digitally signed by ANJANA PACHORI
Date: 2023.12.02 15:03:28 +05'30'
Dy. Manager / WCM

**BHARAT HEPAVY ELECTRICALS LIMITED**

(A Govt of India Undertaking)

High Pressure Boiler Plant, Tiruchirappalli – 620 014, Tamil Nadu
 Ph. No. 0431-2578187, 1519, e-mail: umashankarm@bhel.in, website:
 www.bhel.com

WORKS CONTRACTS MANAGEMENT DEPT.**NOTICE INVITING e-TENDER (Through GeM Portal)**

Please submit your competitive bid for the following scope of work as per the conditions given in the WORK/RATE SCHEDULE enclosed along with the tender.

| SL | Description | Details |
|----|--|--|
| 1 | Scope of Work | Supply, Installation and Maintenance of 13 KL Capacity Thermosiphon Vacuum Insulated Liquid Oxygen (LOX) Cryogenic Vessel and its associated equipment on Rental/Hired Basis at Unit-I, BHEL Trichy Supply, Installation and Maintenance of 13 KL Capacity Non-Thermosiphon Vacuum Insulated Liquid Oxygen (LOX) Cryogenic Vessel and its associated equipment on Rental/Hired Basis at Unit-II, BHEL Trichy |
| 2 | Location of work | BHEL Trichy Complex |
| 3 | Period of contract | Two Years from 01.03.2024 to 28.02.2026 |
| 4 | Last date of receipt of filled-in Tender / Offer | 02.00 p.m. on 11.12.2023 Online bid submission through GeM Portal https://gem.gov.in |
| 5 | Date & Time of opening of techno-commercial bid (Part-I) | 02.30 p.m. on 11.12.2023 Online bid opening through GeM Portal https://gem.gov.in In case bid opening day falls on holiday or happened to be declared as a holiday, opening of the Tender shall automatically fall on the same timing of the next working day |
| 6 | Date & Time of opening of Price Bids (Part-2) | Online bid opening through GeM Portal https://gem.gov.in The date / time of opening of Price Bids will be intimated to all the technically qualified bidders at a later date by BHEL. |
| 7 | Earnest Money Deposit (EMD) | NIL |
| 8 | Contact details for queries related to tender | Anjana Pachori, Dy. Manager/ WCM 0431 257 8187; e-mail: apachori@bhel.in M.Umashankar, Engineer/ WCM; 0431 257 1519; e-mail: umashankarm@bhel.in |
| 9 | Working Area Contact details | S Vijayarajan , Manager / M&S Gas PG Plant Mtce. e-mail : vijayarajan@bhel.in / Ph: 0431 257 5227 |

Date :
Place:

Signature of the Bidder with seal
(Authorized Signatory)

The tender documents comprise the following: -

(I) Part-1 – Techno Commercial Bid

- Annexure-T1 : Terms & conditions for submitting the offers
- Annexure-T2 : Terms & conditions for finalizing the Contract
- Annexure-T3 : Terms & conditions for operation of the Contract
- Annexure-T4 : General Terms & Conditions of the Contract
- Annexure-T5 : Pre-Qualification Requirements (PQRs)

(II) Part-2 – Price Bid

- Annexure-P1 : Price bid - Work / Rate Schedules

Tender can be cancelled at any stage due to unavoidable circumstances. Please note that this is only a request for an Offer and not a Contract.

Dy. Manger / WCM
(Anjana Pachori)

Date :
Place:

Signature of the Bidder with seal
(Authorized Signatory)

PART-1

TECHNO-COMMERCIAL BID

Date :
Place:

Signature of the Bidder with seal
(Authorized Signatory)

ANNEXURE-T1

TERMS & CONDITIONS FOR SUBMITTING THE OFFERS

1. SIGNING THE TENDER DOCUMENTS

- 1.1 The tender & all other connected documents shall be digitally / physically signed by the Authorized Signatory Only. Authorized signatory shall be the person holding 'Power of Attorney' on behalf of the firm/company/Bidder-concerned authorized/empowered, by MD or Board of Directors or authorized person, to act on behalf for the specific purpose of quoting tender and all procedures connected with, till finalization and execution of the Contract.

2. ELIGIBILITY FOR PARTICIPATING IN THIS TENDER

- 2.1 If the bidder has taken any deviation to this tender terms & conditions, and schedules of this tender it lead to total rejection of the offer submitted.
- 2.2 The offers of the Tenderer / bidders who are on the banned / Hold / Under Interim Suspension list and also the offer of the bidders, who engage the services of the banned Hold / Under Interim Suspension firms, shall be rejected. The list of banned Hold / Under Interim Suspension firms is available on BHEL web site (www.bhel.com > Tender Notification > List of Banned Firms).
- 2.3 Even during the course of evaluation/ finalization of tender if it is found that some of the parties are black listed/ barred from business transaction/ under business hold, BHEL will not consider them for further participation in the tender.
- 2.4 If a tenderer or a contractor has a dependent/relative or in the case of a partnership firm, any of its partners or dependents of partners is employed in BHEL, the authority inviting tenders should be informed of this fact at the time of submission of the Tender failing which Tender may be disqualified or if such fact subsequently come to light, the contract may be cancelled.
- 2.5 No BHEL employee and their dependents are eligible to submit their offer against this tender.

3. QUOTING OPTIONS

- 3.1 Quoting
- 3.1.1 Rates should be quoted as per the Work / Rate schedule (Price bid/Part –II). Rates quoted in any other form will not be accepted, and will be rejected.
- 3.2 Quoting best lowest rate and the sanctity of the L1 status.
- 3.2.1 Quoting the lowest best rate is a must against this Tender. However, bidders are required to understand that the lowest rate offered by them or accepted by them, as the case may be, should be honored throughout the tenure of the Contract. During the tenure of the Contract, if any such bidder who have quoted/accepted the lowest rate, do not execute contract as per BHEL's requirements or shun away from doing business with BHEL on some pretext or other, and on whatsoever may be the reason, will be considered as a defaulter and that will purport to sabotaging the total Tendering process of BHEL. Hence BHEL will exercise their right in taking severe action under Contractual obligations including legal action against those bidders.

4. VALIDITY OF OFFERS

- 4.1 The rates quoted shall be valid for acceptance for a minimum period of 120 days from the date of Tender opening. If bidders indulge in withdrawal of Tender or increasing the rates, within this validity period, BHEL will take suitable action as per BHEL's the guidelines of Suspension of Business Dealings with Suppliers / Contractors.

Date :
Place:

Signature of the Bidder with seal
(Authorized Signatory)

- 4.2 After price bid opening but before placement of LOI / Order, if any bidder withdraws his offer / varies it any manner within the validity period, BHEL will initiate suitable penal action against the bidder as per the guidelines of Suspension of Business Dealings with Suppliers / Contractors.

5. SUBMISSION OF OFFERS

- 5.1 Tender only to be submitted electronically by logging to GeM portal i.e. <https://gem.gov.in>. Physical submission of Tender shall not be accepted.
- 5.2 Totally there will be two part bid viz., (i) Techno-Commercial Bid & (ii) Price Bid.

Part – (1)

- 5.3 Techno Commercial Bid consists of the documents Annexure T1 to T5 shall be duly digitally / physically signed & stamped by the bidder in all the pages and uploaded in GeM Portal while submitting offer.
- 5.4 The copies of all the supporting documents uploaded in GeM Portal may be SELF attested by the Bidder concerned.

Part – (2)

- 5.5 The price bids shall be uploaded in GeM Portal while submitting offer.

General

- 5.6 Kindly ensure that the total size of the scanned documents to be uploaded remains minimum. If required, documents may be scanned at lower resolutions say at 150 dpi. However, it shall be sole responsibility of bidder that the uploaded documents remain legible.
- 5.7 Bidder are advised not to wait till the last minutes or last few seconds w.r.t tender closing time to submit their offer to avoid complications related with internet connectivity / network problem/ power failure etc.
- 5.8 Bidders are advised take due care while quoting the technical and price bids forms in the GeM Portal. Bidders, those who tampers with tendering procedure affecting ordering process or misusing the technical information of the tender document or withdrawing their offer after price bid opening, will be penalized as per BHEL guidelines on suspension of business dealings with suppliers/ contractors. Abridged version of the guideline is available in www.bhel.com.
- 5.9 It is advised that all the documents to be submitted are kept scanned or converted to PDF format in a separate folder on your computer before starting online submission.
- 5.10 The bidder has to upload the scanned copy of all the mentioned original documents during online bid-submission.

6. OTHER CONDITIONS

- 6.1 All entries in tender documents shall be clearly written in one ink or typed. All the corrections/cancellations/ insertions, if any, shall be duly attested by the Bidders concerned.
- 6.2 Rates should be quoted as per the Price Bid. Rates quoted in any other form will not be accepted and will be rejected.
- 6.3 The tender shall fill in all the required particulars of the tender documents and also sign on each and every page of the tender documents before submitting their offer.

Date :
Place:

Signature of the Bidder with seal
(Authorized Signatory)

- 6.4 Should a Bidder find discrepancies or omissions in the tender documents or should there any doubt as to their meaning, he should at once address the authority inviting the Tender, for clarification well before the due date, so as to submit his Tender in time. (No extension of time shall be given for submission of the tender on any account)
- 6.5 Conditional offers, offers which are incomplete or otherwise considered defective with respect to tender Terms & conditions and tenders not in accordance with the Terms & Conditions herein contained and the tenders not in original shall be rejected, out rightly, at any point of time during the evaluation process.
- 6.6 If a bidder deliberately gives wrong information in his offer or creates conditions favorable for the acceptance of his offer, the BHEL WILL REJECT SUCH OFFER AT ANY STAGE and take very severe action as per BHEL procedure/ guidelines/ practices.
- 6.7 Canvassing in any form, in connection with the tender is strictly prohibited and such tender are bound to be rejected. All information furnished is taken to be authentic by the Bidder for evaluation of offers. Should any information found to be incorrect subsequently, at any point of time, the LOI / Contract shall be rejected / terminated and the EMD / SD shall be forfeited and take very severe action as per BHEL procedure/ guidelines/ practices.
- 6.8 Should a Bidder's or a Contractor's or in the case of a firm or company of Bidder/any of its shareholder's or shareholder's relative is employed in BHEL, the authority inviting the Tenders shall be informed in writing of this fact at the time of submission of the tender, failing which the offer may be disqualified, or if such fact subsequently comes to light, the LOI / Contract may be cancelled.
- 6.9 The Tender schedule and the total Tender Terms and Conditions shall be deemed to form an integral part of the Contract to be entered into for this work.
- 6.10 BHEL Trichy may at its sole discretion amend the Bidding Documents at any time prior to the deadline for submission of bids. However, in case of such amendment, the bid submission date may be extended at the discretion of BHEL Trichy.
- 6.11 All corrigenda/addenda/amendments/time extensions/clarifications, etc. to the Tender will be hosted on GeM portal, BHEL website only (i.e. <http://www.bhel.com>) and will not be published in any other media. Bidders should regularly visit above website(s) to keep themselves updated.
- 6.12 BHEL may reject the bid or in case the contract has been awarded, then terminate the contract apart from taking any other suitable action under the contract or applicable legal provisions or BHEL guidelines including GeM GTC, without any liability for any compensation to the bidder if, BHEL discovers at any time that any statement made by the bidder in the affidavit cum undertaking is false, fraudulent or any document submitted by the bidder was fake and forged or If BHEL determines in the sole discretion that any statement was aimed at deliberately misleading BHEL with a view to ensure award of the subject contract to the bidder
- 6.13 Expenses incurred by bidder towards preparation of bid incidental to Tender irrespective of whether it is accepted or not, shall be borne by bidder only
- 6.14 In order to avoid unforeseen delay, it is advised that, any correspondence by bidder to BHEL shall be emailed to all the addressees instead of one individual, as mentioned in Tender. The correspondence through email wherever sought by BHEL shall be replied with all the addressees in 'cc' of the mail. Bidder shall furnish valid email id's in the Tender and regularly verify the same.
- 6.15 The Tenderer/Bidder or any of his authorized personnel or agents will be granted permission by the BHEL to enter upon its premises and lands for the purpose of site visit. However, the bidder shall undertake that he, his personnel, and agents will be responsible against all liability in respect thereof, including death or personal injury, loss of or damage to property, and any other loss, damage, costs, and expenses incurred as a result of the inspection.

Date :
Place:

Signature of the Bidder with seal
(Authorized Signatory)

- 6.16 In general, Bidders shall themselves obtain all necessary information. A Bidder shall be deemed to have full knowledge of the Site, whether he inspects it or not and no extra claims due to any misunderstanding or otherwise shall be allowed. The cost of visiting the Site shall be at the Bidders' own expense.
- 6.17 If Tenderer expires after the submission of his Tender or after the acceptance of his Tender the BHEL may, at their discretion, cancels such Tender. If a partner of a firm expires after submission of Tender or after the acceptance of the Tender, BHEL may cancel such Tender at their discretion unless the firm retain its character. The works executed in the own name of the Tenderer only will be considered for eligibility criteria.

7. CONFLICT OF INTEREST

- 7.1 A bidder shall not have conflict of interest with other bidders. Such conflict of interest can lead to anti-competitive practices to the detriment of Procuring Entity's interests. The bidder found to have a conflict of interest shall be disqualified. A bidder may be considered to have a conflict of interest with one or more parties in this bidding process, if:
- 7.1.1 they have controlling partner (s) in common; or
- 7.1.2 they receive or have received any direct or indirect subsidy / financial stake from any of them; or
- 7.1.3 they have the same legal representative / agent for purposes of this bid; or
- 7.1.4 they have relationship with each other, directly or through common third parties, that puts them in a position to have access to information about; or
- 7.1.5 Bidder participates in more than one bid in this bidding process. Participation by a Bidder in more than one Bid will result in the disqualification of all bids in which the parties are involved. this does not limit the inclusion of the components / sub-assembly / Assemblies one bidding manufacturer in more than one bid; or
- 7.1.6 In cases of agents quoting in offshore procurements, on behalf of their principal manufacturers, one agent cannot represent two manufacturers or quote on their behalf in a particular tender enquiry. One manufacturer can also authorise only one agent / dealer. There can be only one bid from the following:
- 7.1.7 The principal manufacturer directly or through one Indian agent on his behalf; and
- 7.1.8 Indian / foreign agent on behalf of only one principal; or
- 7.1.9 A Bidder or any of its affiliates participated as a consultant in the preparation of the design or technical specifications of the contract that is the subject of the Bid; or
- 7.1.10 In case of a holding company having more than one independently manufacturing units, or more than one unit having common business ownership / management, only one unit should quote. Similar restrictions would apply to closely related sister companies. Bidders must proactively declare such sister / common business / management units in same / similar line of business.

Date :
Place:

Signature of the Bidder with seal
(Authorized Signatory)

ANNEXURE-T2

TERMS & CONDITIONS FOR FINALIZING THE CONTRACT

1. METHOD OF EVALUATION OF PRICES

- 1.1 BHEL will finalize the rates through GeM Portal. Hence Tenderers are requested to give their best prices at the first instance itself.
- 1.2 BHEL would negotiate or re-float the Tender opened if L1 price is not the lowest acceptable price to them inter-alia other reasons.
- 1.3 Lowest prices received against BHEL Tenders need not be acceptable price to BHEL and in that case BHEL would not consider the same for award of Contract, despite the price being L1 in the Tender.
- 1.4 In the event of the final L1 prices are not reasonable / acceptable to BHEL; BHEL also may resort to short closure of this Tender.

2. EVALUATION OF TECHNO-COMMERCIAL BIDS

- 2.1 Only those Bidders who meet all the requirements as per Pre-Qualification Requirements (PQR) will be considered for further evaluation. Otherwise offers are liable for rejection.
- 2.2 Then, the Techno-commercial bid of the bidder shall be evaluated for acceptance of technical and commercial terms.
- 2.3 Prior to opening of price bid, BHEL will determine whether each bid is accompanied by required commercial terms & conditions, fulfils the qualifying requirement stated in Bidding Document and compliance to the requirement of the Bidding Document.

3. EVALUATION OF THE PRICE BID

- 3.1 Techno commercially qualified offers will be considered for price evaluation.
- 3.2 Evaluation of offers shall be on the basis of delivered cost (Net cash outflow to BHEL, Trichy i.e. on cumulative L1 value for the entire scope of requirements (Total Net cash outflow to BHEL basis for Fixed facility charges and Mobilisation, Erection & Commissioning charges for both the tanks in Unit-I & Unit-II).
- 3.3 The rental contract will be awarded to a single vendor for the total scope, based on the above evaluation.
- 3.4 In case more than one bidder happens to occupy L-1 status, the L-1 bidder shall be decided by random algorithm of GeM portal.
- 3.5 Ranking will be done accordingly. BHEL decision in such situations shall be final and binding.

4. COUNTER OFFER

- 4.1 Counter offer is applicable for the MSE bidders if the rate quoted is equal or less then L1+15%.
- 4.2 In case of non- MSE bidder become L1, then counter offer will be given to MSE bidders as per merit, if quoted lumpsum value will be within L1+15% and if accepted, contract will be awarded to MSE bidder.

Date :
Place:

Signature of the Bidder with seal
(Authorized Signatory)

5. TAXES AND DUTIES:

5.1 All Taxes and Duties payable as extra to the quoted price should be specifically stated in offers along with GST No. & Service Accounting Code (SAC) failing which the BHEL will not be liable for payment of such Taxes and Duties. BHEL Trichy GST No. 33AAACB4146P2ZL.

6. INCOME TAX APPLICABLE

6.1 Any service charges payable towards supervision of E&C, training, performance prove-out etc., will be released after deduction of Income Tax as per Indian Income Tax Act / as per the Govt. of India rules and TDS certificate will be issued by BHEL for such deductions. Applicable service tax on E&C charges will be payable extra. The liability of depositing the same to the Govt. will be of the bidder. Income tax depreciation will be claimed by BHEL

7. TERMS FOR PRICE BID & RATE BASIS

7.1 Price bid is to be submitted in a separate price bid form provided in the GeM Portal.
7.2 The period of the contract can be extended if required by BHEL and agreed by contractor.
7.3 The rates quoted should be inclusive of GST and inclusive of any taxes and duties levied or to be levied both by Central and State Government authorities from time to time. Such levies should be borne by the Contractor. GST will be paid extra only on submission of documentary evidence.

8. CRITERIA FOR AWARD OF WORK

8.1 The evaluation of offer for award of work shall be on the Lumpsum basis for L1 (lowest bidder).

9. MICRO & SMALL ENTERPRISES (MSE)

9.1 MSE suppliers can avail the intended benefits only if they submit along with the offer, attested copies of either valid UDYAM Registration certificate.
9.2 Date to be reckoned for determining the deemed validity will be the date of bid opening (Part 1 in case of two part bid). Non submission of such documents will lead to consideration of their bid at par with other bidders. No benefit shall be applicable for this enquiry if any deficiency in the above required documents are not submitted before price bid opening. If the tender is to be submitted through GeM Portal, then the above required documents are to be uploaded on the GeM Portal.
9.3 Any new supplier will be eligible for registration with BHEL as MSE supplier provided Valid UDYAM Registration Certificate is submitted along with application for registration.
9.4 However, credentials of all MSE suppliers will be verified before considering the intended benefits for MSE suppliers as per clause (ii) at the time of tender evaluation.
9.5 In case NON-MSE vendor is L1 and MSE vendors offer values are within L1 + 15 %, the L1 offer rate shall be counter offered to MSE Vendors as per merit. 100% work shall be awarded to MSE vendor accepting the counter offered L1 value of Non MSE L1 Vendor.

Date :
Place:

Signature of the Bidder with seal
(Authorized Signatory)

ANNEXURE-T3**TERMS AND CONDITIONS FOR OPERATION OF THE CONTRACT****1. TECHNICAL SPECIFICATION / DETAILED SCOPE OF WORK FOR EACH UNIT****1.1 TECHNICAL SPECIFICATION FOR UNIT-I**

| SL | DESCRIPTION | DETAILS / VENDOR COMPLIANCE |
|----------|---|---|
| 1 | CRYOGENIC LIQUID OXYGEN VESSEL SPECIFICATION | |
| 1.1 | PURPOSE | The cryogenic vessel is required to meet the Oxygen gas requirement for cutting of boiler components at a pressure of 5 to 15 Kg per cm ² (g) in various shop floors through pipeline distribution system and is also required for filling of oxygen gas in industrial cylinders. |
| 1.2 | DESCRIPTION OF VESSEL | The 13 KL (+/-5%) water capacity Liquid oxygen vessel with operating pressure of 17 Kg/cm ² (g) shall be Vertical, Cylindrical, Double Wall, Vacuum + Perlite Insulation type with complete fittings and thermo-siphon system. |
| 1.3 | Qty of LOX Vessel with fittings & thermosiphon system. | One No. |
| 1.4 | Year of Manufacture of Cryogenic Vessel | The year of manufacture of the LOX vessel of 2014 or later is acceptable. LOX Vessels manufactured before 2014 are liable for rejection. |
| 1.5 | General description | The vessel with thermo-siphon system shall be fitted with required fittings like pressure built up coil, cryo-regulator, dual safety valves, other valves, pressure and level gauges, vents, drains, etc., as per the requirement of statutory authorities like M/s PESO (CCOE) and for the operational and maintenance convenient. |
| 1.6 | Name of compressed gas(liquid) to be used | Oxygen |
| 2 | AMBIENT(LOW PRESSURE) VAPORISER UNIT | |
| 2.1 | Quantity | 1 No. |
| 2.2 | Type | Ambient |
| 2.3 | Duty | Continuous duty 24x7 Hrs |
| 2.4 | Material | Vendor to specify |
| 2.5 | Capacity | 400 Nm ³ /Hr |
| 2.6 | Heating medium | Ambient |
| 3 | PRESSURE REGULATING SYSTEM FOR AMBIENT VAPOURISER UNIT | |
| 3.1 | Quantity | 1 No. |
| 3.2 | Inlet Pressure | 17 Kg/cm ² (g) |
| 3.3 | Outlet Pressure | 5 to 15 Kg/cm ² (g) |
| 3.4 | Flow Rate | 0 - 400 Nm ³ /hr. |
| 3.5 | Pressure regulator | 2 Nos.(1 Working + 1 Standby) |
| 3.6 | Out Let Pipe Size | 50 NB |

Date :
Place:Signature of the Bidder with seal
(Authorized Signatory)

| SL | DESCRIPTION | DETAILS / VENDOR COMPLIANCE |
|----------|--|---|
| 4 | PIPE LINES WITHIN STORAGE YARD | |
| 4.1 | Quantity | 1 Lot |
| 4.2 | Pipes and fittings | The pipeline includes all the pipes, pipe fittings, Flanges, Studs, Nuts, Copper jumper, etc., required within LOX storage yard for inter-connecting LOX vessel, LP vaporiser unit and pressure regulating station. Required isolation valves, safety valves, pressure gauges, non-return valve, blow down lines in the piping to be provided. |
| 4.3 | Working Pressure | 5 to 17 Kg/cm ² (g) |
| 4.4 | Design Pressure | Vendor to specify |
| 5 | DETAILS OF EXISTING LIQUID OXYGEN PUMP TO BE USED FOR FILLING OF OXYGEN IN INDUSTRIAL CYLINDERS | |
| 5.1 | Pump model: LOX 36/32 | Vendor to note |
| 5.2 | Pump supplier: M/s Industrial Compressor and Cryo pumps Pvt.Ltd., Faridabad | Vendor to note |
| 5.3 | Type :Reciprocating | Vendor to note |
| 5.4 | Number of pistons : One | Vendor to note |
| 5.5 | Liquid :LOX | Vendor to note |
| 5.6 | Flow : 300 cubic metre/Hr | Vendor to note |
| 5.7 | Maximum Discharge Pressure :165 bar | Vendor to note |
| 5.8 | Operating Pressure : 150 bar | Vendor to note |
| 5.9 | Suction line size: 3/4" | Vendor to note |
| 5.10 | Return line size: 1/2" | Vendor to note |
| 5.11 | Delivery line size: 1/2" | Vendor to note |
| 6 | CIVIL WORKS | |
| 6.1 | The new Vessel has to be installed in the existing Foundation of 13 KL capacity LOX Vessel. | Vendor to comply |
| 6.2 | Foundation bolt with nuts required for Erection of the equipments is in the scope of vendor. | Vendor to comply |
| 6.3 | Required civil works will be carried out by BHEL. | Vendor to note |
| 7 | ERECTION AND COMMISSIONING | |
| 7.1 | Vendor has to arrange necessary cranes, trucks, tools & tackles, man power required for unloading of materials, erection and commissioning of the system. | Vendor to comply |
| 7.2 | BHEL will provide power supply, water, consumables such as welding electrodes, oxy-acetylene gas & LPG at free of cost. | Vendor to comply |
| 7.3 | Required Gas cutting sets, brazing sets, welding machine with accessories will be provided by BHEL at free of cost. | Vendor to comply |
| 7.4 | It is the scope of vendor to take back the installed LOX system at Unit 1 on completion of contract period for which the vendor has to arrange necessary cranes, trucks, tools & tackles, man power required for the work. | Vendor to comply |

Date :
Place:

Signature of the Bidder with seal
(Authorized Signatory)

| SL | DESCRIPTION | DETAILS / VENDOR COMPLIANCE |
|-----------|--|------------------------------------|
| 8 | CCOE LICENSE | |
| 8.1 | Two number of vessels for storing of Liquid Oxygen (each 13 KL capacity) are available in BHEL/HPBP/Unit 1 Premises. One Vessel is BHEL owned and the other is Rented. The existing CCOE license for two number of vessels for storing of Liquid Oxygen in 13 KL capacity Vessel each is valid up to 30/09/2024. | Vendor to comply |
| 8.2 | Required amendment, getting/renewal of CCOE license for the LOX System during the contract period is in the scope of the contractor for which the required license fees will be paid by BHEL. Applicable statutory documents, calibration certificates are to be provided for the LOX System during the contract period by the contractor. | Vendor to comply |
| 9 | MAINTENANCE OF THE LOX SYSTEM | |
| 9.1 | The contractor shall visit BHEL periodically for regular inspection/preventive checking of the LOX system and rectify if any problem is observed in the LOX system for which the required spares and consumables are to be brought by the contractor. | Vendor to comply |
| 9.2 | If any problem is observed in the LOX system during usage by BHEL, the contractor shall rectify the same within 24 hours of intimation for which the required spares and consumables are to be brought by the contractor. | Vendor to comply |
| 10 | DOCUMENTATION : Vendor has to provide the following documents in hardbound(3 Nos.) along with supply of Vessel; | Vendor to comply |
| 10.1 | As built process & Instrumentation diagram of vessel | Vendor to comply |
| 10.2 | Do's and Don'ts | Vendor to comply |
| 10.3 | MSDS of Oxygen | Vendor to comply |
| 10.4 | Standard Operating Procedure of Cryogenic Storage vessel | Vendor to comply |
| 10.5 | Standard Operating procedure for warm filling | Vendor to comply |
| 10.6 | Liquid Level gauge calibration chart | Vendor to comply |
| 10.7 | Volume equivalent chart | Vendor to comply |
| 10.8 | CCOE approved certificate | Vendor to comply |
| 10.9 | Vessel Test Certificate | Vendor to comply |
| 10.10 | SRV Test Certificate (Rule 18) | Vendor to comply |
| 10.11 | Vessel Documents | Vendor to comply |
| 10.12 | Valid Rule 19(if applicable),Rule 33 documents, liquid level gauge calibration certificate, pressure gauge calibration certificates and any other applicable statutory documents shall be submitted along with the manual. | Vendor to comply |
| 11 | CONTRACT VALIDITY | |
| 11.1 | The period of contract is for Two years from the date of PO. | Vendor to comply |

Date :
Place:

Signature of the Bidder with seal
(Authorized Signatory)

| SL | DESCRIPTION | DETAILS / VENDOR COMPLIANCE |
|-----------|---|------------------------------------|
| 11.2 | The contract for Hiring of the LOX Vessel with associated items may be short closed if required after completion of 1 year contract period (i.e between 1st and 2 nd year of the contract period) by BHEL with 3 months prior intimation to the vendor. | Vendor to comply |
| 11.3 | LOX vessel with all associated items should be Erected and Commissioned if applicable with appropriate approval from concerned authorities including CCOE and LOX system should be ready to deliver the oxygen gas within Two months from date of Purchase order. During the period of erection and commissioning of the system (if applicable), temporary arrangement for supply of oxygen with pipelines is to be ensured by the vendor for which no separate additional payment (rental charges) will be made. | Vendor to comply |
| 12 | PAYMENT TERMS | Vendor to comply |
| 12.1 | For the installed equipment, rental charges(fixed facility charges) will be made in monthly basis. | Vendor to comply |
| 12.2 | Separate payment will be made for mobilisation, installation and commissioning of the LOX System if applicable. | Vendor to comply |
| 12.3 | No separate payment will be made for periodic visits, maintenance works, spares during the contract period and for taking back of the LOX System. | Vendor to comply |
| 13 | SPECIFIC NOTE | Vendor to comply |
| 13.1 | Offerer to note that, the contract is for only rental of LOX Vessel with its associated accessories. BHEL reserves the right to fill Liquid Oxygen in the rented LOX Vessel from any of the LOX suppliers during the contract period. | Vendor to comply |

Date :
Place:

Signature of the Bidder with seal
(Authorized Signatory)

1.2 **TECHNICAL SPECIFICATION FOR UNIT-II**

| SL | DESCRIPTION | DETAILS / VENDOR COMPLIANCE |
|----------|---|---|
| 1 | CRYOGENIC LIQUID OXYGEN VESSEL SPECIFICATION | |
| 1.1 | PURPOSE | The cryogenic vessel is required to meet the Oxygen gas requirement for cutting of boiler components at a pressure of 5 to 15 Kg per cm ² (g) in various shop floors through pipeline distribution system. |
| 1.2 | DESCRIPTION OF VESSEL | The 13 KL (+/-5%) water capacity Liquid oxygen vessel with operating pressure of 17 Kg/cm ² (g) shall be Vertical, Cylindrical, Double Wall, Vacuum + Perlite Insulation type with complete fittings. |
| 1.3 | Qty of LOX Vessel with fittings | One No. |
| 1.4 | Year of Manufacture of Cryogenic Vessel | The year of manufacture of the LOX vessel of 2014 or later is acceptable. LOX Vessels manufactured before 2014 are liable for rejection. |
| 1.5 | General description | The vessel shall be fitted with required fittings like pressure built up coil, cryo-regulator, dual safety valves, other valves, pressure and level gauges, vents, drains, etc as per the requirement of statutory authorities like M/s PESO (CCOE) and for the operational and maintenance convenient.t. |
| 1.6 | Name of compressed gas(liquid) to be used | Oxygen |
| 2 | AMBIENT(LOW PRESSURE) VAPORISER UNIT | |
| 2.1 | Quantity | 1 No. |
| 2.2 | Type | Ambient |
| 2.3 | Duty | Continuous duty 24x7 Hrs |
| 2.4 | Material | Vendor to specify |
| 2.5 | Capacity | 400 Nm ³ /Hr |
| 2.6 | Heating medium | Ambient |
| 3 | PRESSURE REGULATING SYSTEM FOR AMBIENT VAPOURISER UNIT | |
| 3.1 | Quantity | 1 No. |
| 3.2 | Inlet Pressure | 17 Kg/cm ² (g) |
| 3.3 | Outlet Pressure | 5 to 15 Kg/cm ² (g) |
| 3.4 | Flow Rate | 0 - 400 Nm ³ /hr. |
| 3.5 | Pressure regulator | 2 Nos.(1 Working + 1 Standby) |
| 3.6 | Out Let Pipe Size | 50 NB |
| 3.7 | General Description | Required safety valves with vent line, pressure gauges, non-return valves, drain lines with valves are to be provided in the pressure regulating station. |
| 4 | PIPE LINES WITHIN STORAGE YARD | |
| 4.1 | Quantity | 1 Lot |
| 4.2 | Pipes and fittings | The pipeline includes all the pipes, pipe fittings, Flanges, Studs, Nuts, Copper jumper, etc., required within LOX storage yard for inter-connecting LOX vessel, LP vaporiser unit and pressure regulating station. Required isolation valves, safety valves, pressure gauges, non-return valve, blow down lines in the piping to be provided. |
| 4.3 | Working Pressure | 5 to 17 Kg/cm ² (g) |
| 4.4 | Design Pressure | Vendor to specify |
| 5 | CIVIL WORKS | |

Date :
Place:

Signature of the Bidder with seal
(Authorized Signatory)

| SL | DESCRIPTION | DETAILS / VENDOR COMPLIANCE |
|----------|---|-----------------------------|
| 5.1 | The new Vessel has to be installed in the existing Foundation of 13 KL capacity LOX Vessel. | Vendor to comply |
| 5.2 | Foundation bolt with nuts required for Erection of the equipments is in the scope of vendor.. | Vendor to comply |
| 5.3 | Required civil works will be carried out by BHEL. | Vendor to note |
| 6 | ERECTION AND COMMISSIONING | |
| 6.1 | Vendor has to arrange necessary cranes, trucks, tools & tackles, man power required for unloading of materials, erection and commissioning of the system. | Vendor to comply |
| 6.2 | BHEL will provide power supply, water, consumables such as welding electrodes, oxy-acetylene gas & LPG at free of cost. | Vendor to comply |
| 6.3 | Required Gas cutting sets, brazing sets, welding machine with accessories will be provided by BHEL at free of cost. | Vendor to comply |
| 6.4 | It is the scope of vendor to take back the installed LOX system at Unit-II on completion of contract period for which the vendor has to arrange necessary cranes, trucks, tools & tackles, man power required for the work. | Vendor to comply |
| 7 | CCOE LICENSE | |
| 7.1 | The existing rental vessel premises license for storing of Liquid Oxygen in 13 KL capacity Vessel is valid up to 30/09/2024. | Vendor to comply |
| 7.2 | Required amendment, getting/renewal of CCOE license for the LOX System during the contract period is in the scope of the contractor for which the required license fees is also in the scope of vendor. Applicable statutory documents, calibration certificates are to be provided for the LOX System during the contract period by the contractor. | Vendor to comply |
| 8 | MAINTENANCE OF THE LOX SYSTEM | |
| 8.1 | The contractor shall visit BHEL periodically for regular inspection/preventive checking of the LOX system and rectify if any problem is observed in the LOX system for which the required spares and consumables are to be brought by the contractor. | Vendor to comply |
| 8.2 | If any problem is observed in the LOX system during usage by BHEL, the contractor shall rectify the same within 24 hours of intimation for which the required spares and consumables are to be brought by the contractor. | Vendor to comply |
| 9 | DOCUMENTATION : Vendor has to provide the following documents in hardbound(3 Nos.) along with supply of Vessel; | Vendor to comply |
| 9.1 | As built process & Instrumentation diagram of vessel | Vendor to comply |
| 9.2 | Do's and Don'ts | Vendor to comply |
| 9.3 | MSDS of Oxygen | Vendor to comply |

Date :
Place:

Signature of the Bidder with seal
(Authorized Signatory)

| SL | DESCRIPTION | DETAILS / VENDOR COMPLIANCE |
|-----------|---|-----------------------------|
| 9.4 | Standard Operating Procedure of Cryogenic Storage vessel | Vendor to comply |
| 9.5 | Standard Operating procedure for warm filling | Vendor to comply |
| 9.6 | Liquid Level gauge calibration chart | Vendor to comply |
| 9.7 | Volume equivalent chart | Vendor to comply |
| 9.8 | CCOE approved certificate | Vendor to comply |
| 9.9 | Vessel Test Certificate | Vendor to comply |
| 9.10 | SRV Test Certificate (Rule 18) | Vendor to comply |
| 9.11 | Vessel Documents | Vendor to comply |
| 9.12 | Valid Rule 19(if applicable),Rule 33 documents, liquid level gauge calibration certificate, pressure gauge calibration certificates and any other applicable statutory documents shall be submitted along with the manual. | Vendor to comply |
| 10 | CONTRACT VALIDITY | Vendor to comply |
| 10.1 | The period of contract is for Two years from the date of PO. | Vendor to comply |
| 10.2 | The contract for Hiring of the LOX Vessel with associated items may be short closed if required after completion of 1 year contract period (i.e between 1st and 2 nd year of the contract period) by BHEL with 3 months prior intimation to the vendor. | Vendor to comply |
| 10.3 | LOX vessel with all associated items should be Erected and Commissioned if applicable with appropriate approval from concerned authorities including CCOE and LOX system should be ready to deliver the oxygen gas within Two months from date of Purchase order. During the period of erection and commissioning of the system (if applicable), temporary arrangement for supply of oxygen with pipelines is to be ensured by the vendor for which no separate additional payment (rental charges) will be made. | Vendor to comply |
| 11 | PAYMENT TERMS | |
| 11.1 | For the installed equipment, rental charges(fixed facility charges) will be made in monthly basis. | Vendor to comply |
| 11.2 | Separate payment will be made for mobilisation, installation and commissioning of the LOX System if applicable. | Vendor to comply |
| 11.3 | No separate payment will be made for regular visits, maintenance works, spares during the contract period and for taking back of the LOX System. | Vendor to comply |
| 12 | SPECIFIC NOTE | |
| 12.1 | Offerer to note that, the contract is for only rental of LOX Vessel with its associated accessories. BHEL reserves the right to fill Liquid Oxygen in the rented LOX Vessel from any of the LOX suppliers during the contract period. | Vendor to comply |

Date :
Place:

Signature of the Bidder with seal
(Authorized Signatory)

1.3 SUPPLIER / BIDDER SCOPE

- 1.3.1 Civil input details like foundation drawing, etc., are to be provided well in advance. (i.e. at least 15 days prior to start of erection)
- 1.3.2 Foundation bolts & nuts, other fasteners required for the erection of equipment should be provided by the bidder.
- 1.3.3 All the necessary license / renewal of license like CCOE & etc., for the installation and operation of LOX and its related associated items shall be in the scope of bidder including all statutory fees (for Unit I alone, the statutory fees is in the scope of BHEL).
- 1.3.4 The installation of pipelines at the outlet of the Liquid Oxygen Vessel and safety valves with vent line, non-return valves, pressure gauges, drain line with valve and isolation valves, etc., is in the scope of the supplier / bidder. Hence visit the site at our complex before submitting your offer and quote accordingly. Vendor has to arrange necessary cranes, truck, tools & tackles, manpower required for unloading of materials, erection and commissioning of the system.
- 1.3.5 To take care of the production needs of BPN/Unit II and SSTP during the transition period for dismantling of the existing LOX vessel and erection & commissioning of the new LOX vessel if applicable, the successful bidder shall make available a temporary arrangement in the form of a portable LOX vessel with built-in vaporiser, of suitable capacity for supplying LOX at 1.5 ton/day at 4 - 15 bar pressure for a period of 10-15 days.

1.4 PREVENTIVE AND BREAKDOWN MAINTENANCE: -

- 1.4.1 Bidder should periodically inspect and certify the healthy operation of the equipment LOX vessel and its associated items as required by BHEL.
- 1.4.2 Required spares for the (Preventive maintenance & Breakdown maintenance and also for the continuous operation of the total installation is at bidder's scope. Moreover one set of critical spares such as safety valve, rupture disc, pressure regulator, NRV, gaskets and etc., to be given to BHEL for emergency purpose.
- 1.4.3 On the occasion of breakdown of the system, bidder should depute their engineer within the possible time and restore the system in to normal operation. In case failure of the system occurs for more than 24 Hrs, penalty @ 2% per day will be charged on the monthly rate and the same will be deducted from the invoice raised by the bidder in respective monthly invoice.

1.5 MANUALS: -

- 1.5.1 Bidder should provide O & M manuals (3 hard copy + 1 soft copy) of LOX built process & instrumentation diagram of vessel.
- 1.5.2 Valid Rule 19(if applicable),Rule 33 documents, liquid level gauge calibration certificate, pressure gauge calibration certificates and any other applicable statutory documents shall be submitted along with the manual.
- 1.5.3 MSDS of Oxygen, Do's & don'ts Standard operating procedure of cryogenic storage vessel.
- 1.5.4 Standard operating procedure of warm filling.
- 1.5.5 Liquid level gauge calibration chart.
- 1.5.6 Volume equivalent chart.
- 1.5.7 CCOE, Tank Test certificate & SRV test certificate.
- 1.5.8 Tank documents and other necessary drawing like layout and individual component on Completion of commissioning of system in case of award of contract

1.6 TRAINING: -

- 1.6.1 On placement of order of the above system, vendor should provide necessary training regarding operation and safety aspects of the Cryogenic equipment/product to BHEL staff.

Date :
Place:

Signature of the Bidder with seal
(Authorized Signatory)

1.7 BHEL SCOPE: -

1.7.1 Providing Civil platform, Power supply, Water, Consumables such as Welding electrodes, Oxy-acetylene gas & LPG will be provided by BHEL

1.8 PERFORMANCE: -

1.8.1 After commissioning of the LOX storage vessel and its accessories its performance will be witnessed by Maintenance & Services department of BHEL

1.9 SPECIFIC NOTE

1.9.1 Vendor to note that, the contract is for only rental of LOX Vessel with its associated accessories. BHEL reserves the right to fill Liquid Oxygen in the rented LOX Vessel from any of the LOX suppliers during the contract period

2. DURATION OF CONTRACT:

2.1 The period of contract is **Two Years** from the date of commissioning with all the required CCOE certificates for regular usage

3. DELIVERY SCHEDULE:

3.1 Erection & Commissioning of tanks shall be completed within 10 to 15 days from the mutually agreed start date for each tank.

3.2 Rental period is for 2 years from the date of Commissioning as certified by Engineer in charge, BHEL-Trichy. The contract may be short closed if required after completion of 1 year contract period (i.e. between 1st and 2nd year of the contract period) by BHEL with 3 months prior intimation to the Bidder / Contractor.

4. PRICE VARIATION CLAUSE

4.1 Fixed price: Prices quoted by the bidder shall be fixed and not subject to any escalation whatsoever during the period of bid validity and execution of the Purchase Order. A bid submitted with an adjustable price will be treated as non - responsive and rejected

5. LIQUIDATED DAMAGES (LD):

5.1 For Monthly rental charges:

5.1.1 On the occasion of breakdown of the system, bidder should depute their engineer within the possible time and restore the system in to normal operation. In case failure of the system occurs for more than 24 Hrs, penalty @ 2% per day will be charged on the monthly rental rate of that tank and the same will be deducted from the monthly invoice raised by the bidder.

5.2 For Mobilisation, Erection and Commissioning:

5.2.1 If the contractor fails to complete the Mobilisation, Erection and Commissioning of a particular tank as per terms & conditions of the order within the delivery schedule, Purchaser shall deduct Liquidated Damages, 0.5% per Day subject to Maximum of 10% of the Mobilisation, Erection and Commissioning Charges of that tank.

Date :
Place:

Signature of the Bidder with seal
(Authorized Signatory)

6. TERMS OF PAYMENT:

6.1 All payments to be made to the contractor, shall be through NEFT (National Electronic Fund Transfer) / RTGS (Real Time Gross Settlement) within reasonable time, as given below, after the certification of bills by the end user / executing agency.

| SL | Type of Firm | Payment Terms |
|----|----------------------------------|---------------|
| 1 | Micro & Small Enterprises (MSEs) | 45 days |
| 2 | Medium Enterprises | 60 days |
| 3 | Non MSME | 90 days |

6.2 Mobilization charges will be paid to the vendor based on the certification from the user department after commissioning and handing over of the system

6.3 For Mobilisation, Erection and Commissioning charges: 100% payment will be made, as per the above terms, from the date of certification by BHEL Engineer in charge.

6.4 Rental period will start after issue of Commissioning Certificate by BHEL Trichy.

6.5 Monthly rental charges become payable at the end of each Month after certification by Engineer in charge, BHEL Trichy. Bidder shall submit the invoice after each Month. 100% monthly rental payment will be made as per the above terms from the date of certification.

6.6 For the installed equipment, fixed facility charges will be made in monthly basis.

6.7 No separate payment will be made for periodic visits, maintenance works, spares during the contract period and for taking back of the LOX System.

6.8 Supplier shall mention their GSTN registration number in all their invoices and invoices shall be in the format as specified/prescribed under GST laws for processing the bills on monthly basis.

6.9 Statutory deduction like IT etc. will be deducted from contractor payment as required by Law.

6.10 INCOME TAX:

6.11 Income Shall be deducted at the applicable rate in respect of the service contract including supply of labour for any work as follows:

6.12 Self-attested copy of PAN card shall be submitted to Account Dept. along with original for verification.

6.13 TDS Certificate will be issued to vendors for each quarter ending as on 30th June, 30th Sept, 31st Dec and 31st Mar during the following quarter.

6.14 GST:

6.14.1 Wherever GST is liable to be paid by the contractor, the contractor shall register himself under the GST Rules and a Self-attested copy of Certificate of Registration shall be furnished to Account Dept.

6.14.2 After registration, the payment of GST shall be effected by the contractor to the Central Government monthly/quarterly based on the invoices raised before the due date of payment. The GST Return also shall be submitted to the Government before the due date.

6.15 The invoice/bill in original duly signed by the contractor claiming the payment for GST shall clearly indicate the following:

6.15.1.1 Continuous Serial no. & date of the bill

6.15.1.2 Cost of the service

6.15.1.3 Separately showing the GST amount calculated at the applicable rate

6.15.1.4 PAN based GST Registration No.

Date :

Place:

Signature of the Bidder with seal
(Authorized Signatory)

- 6.16 The GST claimed in the bill will be paid to the contractor based on the proof of payment of GST to the Government for the previous month/quarter as the case may be.
- 6.17 GST shall be shown extra in the bid. Bharat Heavy Electricals Limited, Trichy will not entertain any claim what so ever in this respect after opening the tenders. Also GST Registration number has to be provided as applicable.
- 6.18 All payments from BHEL in view of the execution of the contract are liable for Works Contract Tax, Income Tax (TDS), GST, PF & Group Insurance and all other statutory provisions as applicable. Hence, bidders shall confirm that they have suitable mechanism for effective compliance to the same.

7. AVAILING INPUT TAX CREDIT (ITC):

- 7.1 As per GST in line with new GST Return System from 1st Oct 2019.

8. GOODS & SERVICE TAX (GST) REGISTRATION & COMPLIANCE

- 8.1 Response to Tenders for Indigenous supplier will be entertained only if the vendor has a valid GST registration Number (GSTIN) which should be clearly mentioned in the offer. If the dealer is exempted from GST registration, a declaration with due supporting documents need to be furnished for considering the offer. Dealers under composition scheme should declare that he is a composition dealer supported by the screen shot taken from GSTN portal.
- 8.2 The dealer has to submit necessary documents if there is any change in status under GST.
- 8.3 Supplier shall mention their GSTIN in all their invoices (incl. credit Notes, Debit Notes) and invoices shall be in the format as specified/prescribed under GST laws. Invoices shall necessarily contain Invoice number (in case of multiple numbering system is being followed for billing like SAP invoice no, commercial invoice no etc., then the Invoice No. which is linked/uploaded in GSTN network shall be clearly indicated), Billed to party (with GSTIN) & Shipped to party details, item description as per PO, Quantity, Rate, Value, applicable taxes with nomenclature (like IGST, SGST, CGST & UTGST) separately, HSN/ SAC Code, Place of Supply etc. Wherever E-Invoice is applicable, the tax invoice/ CN / DN submitted by the vendor must contain the QR code generated in E-Invoice Portal & IRN.
- 8.4 All invoices shall bear the HSN Code for each item separately (Harmonized System of Nomenclature)/ SAC code (Services Accounting Code)
- 8.5 Invoices will be processed only upon completion of statutory requirement and further subject to following:
- 8.5.1 Vendor declaring such invoice in their GSTR-1 Return/ IFF
- 8.5.2 Receipt of Goods or Services and Tax invoice by BHEL
- 8.6 As the continuous uploading of tax invoices in GSTN portal (in GSTR-1/ IFF) is available for all (i.e. both Small & Large) tax payers, all invoices raised on BHEL may be uploaded immediately in GST portal on dispatch of material /rendering of services. The supplier shall ensure availability of Invoice in GSTN portal before submission of invoice to BHEL. Invoices will be admitted by BHEL only if the invoices are available in GSTN portal (in BHEL's GSTR-2A/ GSTR-2B).
- 8.7 In case of discrepancy in the data uploaded by the supplier in the GSTN portal or in case of any shortages or rejection in the supply, then BHEL will not be able to avail the tax credit and will notify the supplier of the same. Supplier has to rectify the data discrepancy in the GSTN portal or issue credit note or debit note (details also to be uploaded in GSTN portal) for the shortages or rejections in the supplies or additional claims, within the calendar month informed by BHEL.

Date :
Place:

Signature of the Bidder with seal
(Authorized Signatory)

- 8.8 In cases where invoice details have been uploaded by the vendor but failed to remit the GST amount to GST Department (Form PMT-08 or Form GST RET-01 to be submitted) within stipulated time, then GST paid on the invoices pertaining to the month for which GST return not filed by the vendor will be recovered from the vendor along with the applicable interest (currently 24% p.a) and all subsequent bills of the vendor will not be processed till filing of the GST return by the vendor
- 8.9 In case GST credit is denied to BHEL due to non-receipt or delayed receipt of goods and/ or tax invoice or expiry of timeline prescribed in GST law for availing such ITC, or any other reasons not attributable to BHEL, GST amount claimed in the invoice shall be disallowed to the vendor.
- 8.10 Where any GST liability arising on BHEL under Reverse Charge (RCM), the vendor has to submit the invoices to BHEL well within the timeline prescribed in GST Law, to enable BHEL to discharge the GST liability. If there is a delay in submission of invoice by the vendor resulting in delayed payment of GST by BHEL along with Interest, then such Interest payable or paid shall be recovered from the vendor.
- 8.11 GST TDS will be deducted as per Section 51 of CGST Act 2017 and in line with Notification 50/2018 –Central Tax dated 13.09.2018. GST TDS certificate will be generated in GSTN portal subsequent to vendor accepting the TDS deduction in the GSTN portal & the vendor can directly download the Certificate from the GSTN Portal.

9. FORCE MAJEURE CLAUSE:

- 9.1 If, at any time during the continuance of this Contract the performance in whole or in part by either party of any obligations under this Contract shall be prevented or delayed by reason of any War, Hostile acts of the public enemy Civil Commotion, Epidemics, or Acts of God (Floods, Storm/Cyclone, Hurricane, Earth Quake etc.) then provided notice of happening of any such event is given by either party to other within 7 days from the date of occurrence therefor neither party shall by reason of such event be entitled to terminate this Contract nor shall either party have any claim for damages against the other in respect of such non-performance and delay in performance under the Contract shall be resumed as soon as practicable after such event has come to an end or ceased to exist. If the performance in whole or part of any obligation under this Contract is prevented or delayed by reason of any such event, claims for extension of time shall be granted for periods considered reasonable by BHEL subject to prompt notification by the Contractor.

10. INDEMNITY:

- 10.1 The Contractor shall have to indemnify BHEL against all claims for injury or damage to any person or property caused by his negligence or negligence of his employees whilst in BHEL premises / sites.
- 10.2 The Contractor shall indemnify the company against all payments by way of compensation or otherwise which the company may be called upon to make under the provisions of the applicable Acts to any Contract employee as aforesaid, and any cost incurred by the company in connection with any claim preferred by such Contract employee and or against all actions, claims and demands whatsoever in respect thereof or in respect of any loss, injury or damages whatsoever to any third person arising out of or occasioned by the negligent, imperfect or improper performance of this Contract by the Contractor, their employee servants or agents.
- 10.3 The Contractor approved and operating under the Tender, Works Contracts shall further indemnify BHEL against: -
- 10.3.1 Observance of Labour & Industrial Laws.
- 10.3.2 All claims by way of compensation and all other types of unforeseen claims, which may arise in the course of Contract.
- 10.3.3 Documentary compliance relating to billing.

Date :
Place:

Signature of the Bidder with seal
(Authorized Signatory)

11. INSURANCE POLICIES

11.1 The Contractor shall at his own cost take insurance and maintain at all times until the close out of the Contract, insurance policies in respect of equipment and workmen engaged by him for providing services under this Contract.

**12. WORKING CONDITIONS:
(FOR MOBILISATION, ERECTION AND COMMISSIONING)**

12.1 The contractor shall provide all safety devices and personal protective equipment to his workmen at his own cost and shall ensure that his workmen wear / use such device or equipment provided to them while doing the work and there should not be any relaxation on this.

12.2 The Contractor shall ensure that his workmen movement is restricted to their relevant work areas only & shall vacate the premises after the shift is over

12.3 The Contractor should bring contract labour to BHEL premises at his/her own cost, risk and execute the work allotted to him in BHEL premises. All safety equipment's to the workmen, safety rules & regulations are to be followed as per BHEL's Safety Rules & Regulations.

12.4 BHEL will no way be responsible for any loss of life or any injury caused to any of the contractors or their crew while executing the above work at BHEL premises.

13. NOTICES OF ACCIDENTS:

13.1 In the event of an accident the contractor shall be required to fill injury report and submit to the Engineer In-charge immediately and ensure compliance of ESI / Workmen's Compensation of accident as per the Act.

14. SAFETY CONDITIONS & GUIDELINES

14.1 The Factories' Act, 1948:

14.1.1 Section 32: Floors, stairs and means of access shall be properly maintained to ensure safety. Every place of working should have safe access. When any person has to work at a height from which he is likely to fall, provision shall be made, so far as is reasonably practicable, by fencing or otherwise, to ensure the safety of person so working.

14.2 Tamil Nadu Factories' Rules, 1950

14.2.1 Rule 55: Hoists and Lifts & Rule 55A. Lifting machines, chains, ropes and lifting tackles: Shall be maintained in good condition, thoroughly inspected and examined by competent persons and records to be maintained.

14.2.2 Rule 57: Excessive Weights: No person shall, unaided by another person, lift, carry or move by hand or on head, any material, article, tool or appliance exceeding the maximum limit in weight set out in the schedule (50 kg for adult male and 30 kg for adult female).

14.2.3 Rule 61E: Machinery and plant: No machinery, plant or equipment shall be constructed, situated, operated or maintained in any factory in such a manner as to cause risk of bodily injury.

14.2.4 Rule 61F: Methods of Work: No process or work shall be carried on in any factory in such a manner as to cause risk of bodily injury.

14.2.5 Rule 61G: Stacking and storing of materials etc.: No materials or equipment shall be stacked or stored in such a manner as to cause risk of bodily injury.

Date :
Place:

Signature of the Bidder with seal
(Authorized Signatory)

- 14.2.6 Rule 61-K. Examination of eye sight of certain workers: No person shall be employed to operate a crane or to give signals to crane operator unless his eye sight and colour vision have been examined and declared fit by a qualified ophthalmologist.
- 14.2.7 Rule 61-N and Rule 61- O: Workers to be provided with Personal Protective equipment suitable for the hazards and should be of good quality / have certification by Indian Standard Institute.
- 14.2.8 Note: For the type of work envisaged, personal protective equipment such as helmet, safety shoes and gloves are essential.
- 14.2.9 Rule 96: Notification of accidents: Shall be complied with as required in the Factories Act (Section 88 and Section 88A) and Tamil Nadu Factories Rules.

15. EQUIPMENT:

- 15.1 All the equipment used by the contractors are to be in good condition with all safety provisions and to be checked and certified by the department officials.
- 15.2 Electrical supply to be taken through the M&S department. Unauthorized connections taken any will be viewed seriously.
- 15.3 Welding machines are to be used with proper earth connection. Cables should be in good condition. Insulation to be checked regularly and maintained.
- 15.4 Qualified electricians are only to be used for giving connections.
- 15.5 Good quality Electrical equipment and tools are to be used with valid certificates. These certificates must be shown on demand.
- 15.6 For portable electrical equipment supply to be taken using plugs points.
- 15.7 Wires / cables extension box should be in good condition.
- 15.8 Proper earthing should be maintained.
- 15.9 Mobile Crane, Fork lift, Trailers; JCB etc. should be in good condition with specified capacity and should not cause any untoward incident while in use.
- 15.10 Fitness Certificate issued by competent person approved by Govt. authorities, insurance and emission certificate etc. should be in possession and should be shown on demand.

16. SAFETY EQUIPMENT:

During mobilisation, erection and commissioning activities, Contract employees must wear the PPEs relevant to the nature of work in addition to the safety shoes.

- 16.1 Welding - Welding Shield and goggles
- 16.2 Gas cutting - Aprons, Gas cutting goggles
- 16.3 Painting - PVC gloves, PVC apron, respirators
- 16.4 Electrical work - Electrical Resistance gloves, gum boots (during rain)
- 16.5 Work near hot furnace - Heat resistant gloves or Apron
- 16.6 Glass wool related works - Respirators, Barrier Cream
- 16.7 Slag removal, cleaning and grinding work - Goggles / dust respirators.
- 16.8 Handling of rough and sharp surfaced objects - Leather gloves
- 16.9 Concrete preparation - Gum boots Electrical
- 16.10 Work at height - Rubber gloves, Safety Belt, fall arrestors, Life line Rope

Date :
Place:

Signature of the Bidder with seal
(Authorized Signatory)

17. PREFERENCE TO MAKE IN INDIA:

- 17.1 For this procurement, the local content to categorize a supplier as a Class I local supplier/ Class II local Supplier/ Non Local supplier and purchase preference to Class I local supplier, is as defined in Public Procurement (Preference to Make in India), Order 2017 dated 04.06.2020 issued by DPIIT. In case of subsequent orders issued by the nodal ministry, changing the definition of local content for the items of the NIT, the same shall be applicable even if issued after issue of this NIT, but before opening of Part-II bids against this NIT.

18. BHEL's FRAUD PREVENTION POLICY

- 18.1 The Bidder along with its associate/ collaborators/ sub – vendors/ consultants/ service providers shall strictly adhere to BHEL Fraud Prevention Policy displayed on BHEL website <http://www.bhel.com> and shall immediately bring to the notice of BHEL Management about fraud or suspected fraud as soon as it comes to their notice. Fraud Prevention policy and List of Nodal Officers shall be hosted on BHEL website, vendor portals of Units / Regions intranet.

19. BHEL'S GUIDELINES FOR SUSPENSION OF BUSINESS DEALINGS WITH SUPPLIERS / CONTRACTORS:

- 19.1 Penal action can be initiated on the suppliers / Contractors in line with extant 'Guidelines for Suspension of Business Dealings with Suppliers/ Contractors'. The abridged version of extant 'Guidelines for suspension of business dealings with suppliers/ contractors' has been uploaded on <http://www.bhel.com> on "supplier registration page".
- 19.2 The offers of the bidders who are under suspension as also the offers of the bidders, who engage the services of the banned firms, shall be rejected. The list of banned firms is available on BHEL web site www.bhel.com.

20. INTEGRITY COMMITMENT, PERFORMANCE OF THE CONTRACT AND PUNITIVE ACTION THEREOF:

- 20.1 Commitment by BHEL: BHEL commits to take all measures necessary to prevent corruption in connection with the tender process and execution of the contract. BHEL will during the tender process treat all Bidder(s) in a transparent and fair manner, and with equity.
- 20.2 Commitment by Bidder/ Supplier/ Contractor: The bidder/ supplier/ contractor commit to take all measures to prevent corruption and will not directly or indirectly influence any decision or benefit which he is not legally entitled to nor will act or omit in any manner which tantamount to an offence punishable under any provision of the Indian Penal Code, 1860 or any other law in force in India.
- 20.3 The bidder/ supplier/ contractor will, when presenting his bid, disclose any and all payments he has made, and is committed to or intends to make to agents, brokers or any other intermediaries in connection with the award of the contract and shall adhere to relevant guidelines issued from time to time by Govt. of India/ BHEL.
- 20.4 The bidder/ supplier/ contractor will perform/ execute the contract as per the contract terms & conditions and will not default without any reasonable cause, which causes loss of business/ money/ reputation, to BHEL.
- 20.5 If any bidder/ supplier/ contractor during pre-tendering/ tendering/ post tendering/ award/ execution/ post-execution stage indulges in mal-practices, cheating, bribery, fraud or and other misconduct or formation of cartel so as to influence the bidding process or influence the price or acts or omits in any manner which tantamount to an offence punishable under any provision of the Indian Penal Code, 1860 or any other law in force in India, then, action may be taken against such bidder/ supplier/ contractor as per extant guidelines of the company available on [www. bhel.com](http://www.bhel.com) and/or under applicable legal provisions.

Date :
Place:

Signature of the Bidder with seal
(Authorized Signatory)

21. COMPENSATION CLAUSE FOR CONTRACTS VALUING ₹5 LAKHS AND ABOVE.

21.1 BHEL shall recover the amount of compensation paid to victim(s) by BHEL towards loss of life / permanent disability due to an accident which is attributable to the negligence of contractor, agency or firm or any of its employees as detailed below.

21.1.1 Victim: Any person who suffers permanent disablement or dies in an accident as defined below

21.1.2 Accident: Any death or permanent disability resulting solely and directly from any unintended and unforeseen injurious occurrence caused during the manufacturing / operation and works incidental thereto at BHEL factories/ offices and precincts thereof, project execution, erection and commissioning, services, repairs and maintenance, trouble shooting, sewing, overhaul, renovation and retrofitting, trial operation, performance guarantee testing undertaken by the company or during any works / during working at BHEL Units/ Offices/ townships and premises/ Project Sites.

21.1.3 Compensation in respect of each of the victims:

- (i) In the event of death or permanent disability resulting from Loss of both limbs: ₹ 10,00,000/- (Rupees Ten Lakh)
- ii) In the event of other permanent disability: ₹ 7,00,000/- (Rupees Seven Lakh)

21.1.4 Permanent Disablement: A disablement that is classified as a permanent total disablement under the proviso to Section 2 (l) of the Employee's Compensation Act, 1923

22. SECRECY OF CONFIDENTIAL INFORMATION:

22.1 The Contractor undertakes and agrees that he/it will not disclose or reveal in part or full the proprietary/confidential information, which terms shall mean and include patents, trademarks, service marks, registered designs, copyright, design rights, know-how, confidential information, trade and business names and any other similar protected information of BHEL received during negotiation or currency of the contract to any third party or governmental authorities without written permission from BHEL. In the event of termination or expiry of the contract, the contractor shall return all proprietary/confidential information to BHEL. This clause shall survive termination or expiry of the contract.

22.2 All the input details: transmittals and sample drawings supplied for preparation of drawings are confidential information of BHEL for specific purpose only. The contractor shall never pass on / part with the information to anybody and shall maintain the secrecy of the information. As soon as the bills are certified by BHEL, all the relevant drawing files shall be erased from PCs and shall not be made use under any circumstances.

22.3 BHEL reserves the right to initiate appropriate action including legal proceeds / termination of contract, recovery of damages, penalties etc., if the contractor is found guilty / wrong usage of the documents given by BHEL for any unauthorised activity.

23. RISK PURCHASE:

23.1 In case of abnormal delays (beyond the maximum late delivery period as per LD clause) or non-fulfilment of any other terms and conditions given in work order, BHEL may cancel the work order in full or part thereof, and may also make a contract of such work/service from elsewhere / alternative source at the risk and cost of the original contractor. BHEL will take all reasonable steps to complete the contract obligations from alternate source at optimum cost. If bidder does not agree to the above Risk Purchase Clause, BHEL reserves the right to reject the offer. In case for compelling reasons BHEL accepts the offer without acceptance of this clause by the bidder and in the eventuality of Risk Purchase, appropriate action will be taken as per BHEL extant rules. This will be without prejudice to any other right of BHEL under the contract. Risk & cost clause, in line with conditions of contract may be invoked in any of the following cases:

Date :
Place:

Signature of the Bidder with seal
(Authorized Signatory)

- 23.1.1 Contractor's poor progress of the work vis-à-vis execution timeline as stipulated in the contract, backlog attributable to contractor/ supplier including unexecuted portion of work/ supply does not appear to be executable within balance available period (#) considering its performance of execution.
- 23.1.2 Withdrawal from or abandonment of the work by contractor before completion of the work as per contract.
- 23.1.3 Non completion of work / Non-supply by the contractor within scheduled completion/delivery period as per contract or as extended from time to time, for the reason attributable to the contractor.
- 23.1.4 Termination of contract on account of any other reason (s) attributable to contractor.
- 23.1.5 Assignment, transfer, subletting of contract without BHEL's written permission resulting in termination of Contract or part thereof by BHEL.
- 23.1.6 Non-compliance to any contractual condition or any other default attributable to contractor.
- 23.1.7 Risk and Cost amount against balance work will be calculated as follows:

Risk & Cost Amount= [(A-B) + (A x H/100)]

Where,

A= Value of Balance scope of Work/ Supply (*) as per rates of new contract

B= Value of Balance scope of Work/ Supply (*) as per rates of old contract being paid to the contractor/ supplier at the time of termination of contract i.e. inclusive of PVC & ORC, if any.

H = Overhead Factor to be taken as 5

In case (A-B) is less than 0 (zero), value of (A-B) shall be taken as 0 (zero).

*(Balance scope of work/ supply)

- 23.2 Difference of Contract Quantities and Executed Quantities as on the date of issue of Letter for 'Termination of Contract', shall be taken as balance scope of Work/ Supply for calculating risk & cost amount.
- 23.3 Contract quantities are the quantities as per original contract. If, Contract has been amended, quantities as per amended Contract shall be considered as Contract Quantities.
- 23.4 Items for which total quantities to be executed have exceeded the Contract Quantities based on drawings issued to contractor from time to time till issue of Termination letter, then for these items total Quantities as per issued drawings would be deemed to be contract quantities.
- 23.5 Substitute/ extra items whose rates have already been approved would form part of contract quantities for this purpose. Substitute/ extra items which have been executed but rates have not been approved, would also form part of contract quantities for this purpose and rates of such items shall be determined in line with contractual provisions.
- 23.6 However, increase in quantities on account of additional scope in new tender shall not be considered for this purpose.
- 23.7 NOTE: In case portion of work is being withdrawn, contract quantities pertaining to portion of work withdrawn shall be considered as 'Balance scope of work/supply' for calculating Risk & Cost amount.

24. SECURITY DEPOSIT

- 24.1 Security Deposit means the security provided by the Contractor towards fulfilment of any obligations in terms of the provisions of the contract.
- 24.2 The total amount of Security Deposit will be 5% of the contract value.
- 24.3 EMD of the successful tenderer will be converted and adjusted towards the required amount of Security Deposit.

Date :
Place:

Signature of the Bidder with seal
(Authorized Signatory)

- 24.4 Submission of Security Deposit by the Contractors
- 24.4.1 At least 50% of the required Security Deposit, including the EMD, will be collected before start of the work. Balance of the Security Deposit will be collected by deducting 10% of the gross amount progressively from each of the running bills of the Contractor till the total amount of the required Security Deposit is collected.
- 24.4.2 In case of delay in submission of performance security, enhanced performance security which would include interest (Repo rate + 4%) for the delayed period, shall be submitted by the bidder.
- 24.4.3 If the value of work done at any time exceeds the contract value, the amount of Security Deposit will be correspondingly enhanced and the additional Security Deposit shall be immediately deposited by the Contractor or recovered from payment/s due to the Contractor.
- 24.4.4 The recoveries made from running bills (cash deduction towards balance SD amount) will be released against submission of equivalent Bank Guarantee in acceptable form, but only once, before completion of work, with the approval of the authority competent to award the work.
- 24.4.5 (Note: In case of small value contracts not exceeding Rs. 20 lakhs, work can be started before the required Security Deposit is collected. However, payment can be released only after collection/ recovery of initial 50% Security Deposit).
- 24.5 The balance amount to make up the required Security Deposit of the contract value may be accepted in the following forms:
- 24.5.1 Cash (as permissible under the extant Income Tax Act
- 24.5.2 Local cheques of Scheduled Banks (subject to realization)/ Pay Order/ Demand Draft/ Electronic Fund Transfer in favour of BHEL
- 24.5.3 Bank Guarantee from Scheduled Banks/ Public Financial Institutions as defined in the Companies Act. The Bank Guarantee format should have the approval of BHEL
- 24.5.4 Securities available from Indian Post offices such as National Savings Certificates, Kisan Vikas Patras etc. (held in the name of Contractor furnishing the security and duly endorsed/ hypothecated/ pledged, as applicable, in favour of BHEL)
- 24.5.5 Insurance Surety Bonds
(Note: BHEL will not be liable or responsible in any manner for the collection of interest or renewal of the documents or in any other matter connected therewith)
- 24.6 Security Deposit shall be released by BHEL to the Contractor upon fulfilment of contractual obligations as per terms of the contract.
- 24.7 The Security Deposit shall not carry any interest.
- 24.8 In case of failure of the contractor to fulfil any of the tender / Contract obligations, either the whole of the contract or any part or in case actions under the Guidelines for Suspension of Business Dealings with Suppliers and Contractors is taken against a contractor, EMD and Security Deposit shall be liable for forfeiture as per BHEL Guidelines.

25. BREACH OF CONTRACT, REMEDIES AND TERMINATION

In case of breach of contract, wherever the value of security instruments like performance bank guarantee available with BHEL against the said contract is atleast 10% of the contract value, the same be encashed. In case the value of the security instruments available is less than 10% of the contract value, the balance amount be recovered from other financial remedies (i.e. available bills of the contractor, retention amount, etc. with BHEL) or legal remedies be pursued.

- 25.1 Further, levy of liquidated damages, debarment, termination, de-scoping, short-closure, etc., shall be applied as per provisions of the contract.
- 25.2 Accordingly, recovery of an amount equivalent to 10% of the contract value will be recovered in case of breach of contract.

Date :
Place:

Signature of the Bidder with seal
(Authorized Signatory)

26. RESOLUTION OF DISPUTES

- 26.1 The Parties agree that if at any time (whether before, during or after the arbitral or judicial proceedings), any Disputes (which term shall mean and include any dispute, difference, question or disagreement arising in connection with construction, meaning, operation, effect, interpretation or breach of the contract/tender which the Parties are unable to settle mutually), arise inter-se the Parties, the same may, be referred by either party to Conciliation to be conducted through Independent Experts Committee to be appointed by competent authority of BHEL from the BHEL Panel of Conciliators.
- 26.2 The proceedings of Conciliation shall broadly be governed by Part-III of the Arbitration and Conciliation Act 1996 or any statutory modification thereof.
- 26.3 Notes:
- 26.3.1 No serving or a retired employee of BHEL/Administrative Ministry of BHEL shall be included in the BHEL Panel of Conciliators.
- 26.3.2 Any other person(s) can be appointed as Conciliator(s) who is/are mutually agreeable to both the parties from outside the BHEL Panel of Conciliators.
- 26.4 The proceedings of Conciliation shall broadly be governed by Part-III of the Arbitration and Conciliation Act 1996 or any statutory modification thereof and as provided in Annexure ... to the Terms and conditions of the tender.
- 26.5 The Annexure-1 together with its appendices will be treated as if the same is part and parcel hereof and shall be as effectual as if set out herein in the terms and conditions of the tender.
- 26.6 Except as provided elsewhere in this Contract, in case amicable settlement is not reached between the parties, in respect of any dispute or difference; arising out of the formation, breach, termination, validity or execution of the Contract; or, the respective rights and liabilities of the Parties; or, in relation to interpretation of any provision of the Contract ; or , in any manner touching upon the Contract, then, either Party may , by a notice in writing to other Party refer such dispute or difference to sole arbitration of an arbitrator appointed as per the Arbitration and Conciliation Act, 1996 (India) or statutory modification or re-enactment thereof and the rules made thereunder and for the time being in force .
- 26.7 The Arbitrator shall pass a reasoned award and the award of the Arbitrator shall be final and binding upon the parties.
- 26.8 Subject as aforesaid, the provision of Arbitration & Conciliation Act 1996 (India) or statutory modification or re-enactment thereof and the rules made thereunder and for the time being in force shall apply to the arbitration proceeding under this clause.
- 26.9 The seat of arbitration shall be the place from which the Contract is issued.
- 26.10 The cost of arbitration shall be borne as per the award of the Arbitrator.
- 26.11 Subject to arbitration in terms of clause above, the Courts at the place from which the Contract is issued shall have exclusive jurisdiction over any matter arising out of or in connection with this Contract.
- 26.12 Notwithstanding the existence or any dispute or difference and/or reference for the arbitration, the vendor shall proceed with and continue without hindrance the performance of its obligation under this Contract with due diligence and expedition in a professional manner except where the Contract has been terminated by either Party in terms of this Contract.
- 26.13 In Case of Contract with Public Sector Enterprise (PSE) or a Government Department, the following shall be applicable:

Date :
Place:

Signature of the Bidder with seal
(Authorized Signatory)

- 26.14 In the event of any dispute or difference relating to the interpretation and application of the provisions of commercial contract(s) between Central Public Sector Enterprises (CPSEs)/Port Trusts inter se and also between CPSEs and Government Departments/Organizations (Excluding disputes concerning Railways, Income Tax, Customs & Excise Departments, such dispute or difference shall be taken up by either party for resolution through AMRCD as mentioned in DPE OM No. 4(1)/2013 –DPE (GM)/FTS-1835 dated 22-05-2018.

ANNEXURE-1

BRIEF PROCEDURE FOR CONDUCT OF CONCILIATION PROCEEDINGS

1. The proceedings of Conciliation shall broadly be governed by Part-III of the Arbitration and Conciliation Act 1996 or any statutory modification thereof and as provided herein:
2. The party desirous of resorting to Conciliation shall send an invitation/notice in writing to the other party to conciliate specifying all points of Disputes with details of the amount claimed. The party concerned shall not raise any new issue thereafter. Parties shall also not claim any interest on claims/counter-claims from the date of notice invoking Conciliation till the conclusion of the Conciliation proceedings.
3. The party receiving the invitation/notice for Conciliation shall within 30 days of receipt of the notice of Conciliation intimate its consent for Conciliation along with its counter-claims, if any.
4. The Conciliation in a matter involving claim or counter-claim (whichever is higher) up to Rs 5 crores shall be carried out by sole Conciliator nominated by BHEL while in a matter involving claim or counter-claim (whichever is higher) of more than Rs 5 crores
5. Conciliation shall be carried out by 3 Conciliators nominated by BHEL.
6. The Parties shall be represented by only their duly authorized in-house executives/officers and neither Party shall be represented by a Lawyer.
7. The first meeting of the IEC shall be convened by the IEC by sending appropriate communication/notice to both the parties as soon as possible but not later than 30 days from the date of his/their appointment. The hearings in the Conciliation proceeding shall ordinarily be concluded within two (2) months and, in exceptional cases where parties have expressed willingness to settle the matter or there exists possibility of settlement in the matter, the proceedings may be extended by the IEC by a maximum of further 2 months with the consent of the Parties subject to cogent reasons being recorded in writing.
8. The IEC shall thereafter formulate recommendations for settlement of the Disputes supported by reasons at the earliest but in any case within 15 days from the date of conclusion of the last hearing. The recommendations so formulated along with the reasons shall be furnished by the IEC to both the Parties at the earliest but in any case within 1 month from the date of conclusion of the last hearing.
9. Response/modifications/suggestions of the Parties on the recommendations of the IEC are to be submitted to the IEC within time limit stipulated by the IEC but not more than 15 days from the date of receipt of the recommendations from the IEC.
10. In the event, upon consideration, further review of the recommendations is considered necessary, whether by BHEL or by the other Party, then, the matter can be remitted back to the IEC with request to reconsider the same in light of the issues projected by either/both the Parties and to submit its recommendations thereon within the following 15 days from the date of remitting of the case by either of the Parties.

Date :
Place:

Signature of the Bidder with seal
(Authorized Signatory)

11. Upon the recommendations by the Parties, with or without modifications, as considered necessary, the IEC shall be called upon to draw up the Draft Settlement Agreement in terms of the recommendations.
12. When a consensus can be arrived at between the parties only in regard to any one or some of the issues referred for Conciliation the draft Settlement Agreement shall be accordingly formulated in regard to the said Issue(s), and the said Settlement Agreement, if signed, by the parties, shall be valid only for the said issues. As regards the balance issues not settled, the parties may seek to resolve them further as per terms and conditions provided in the contract.
13. In case no settlement can be reached between the parties, the IEC shall by a written declaration, pronounce that the Conciliation between the parties has failed and is accordingly terminated.
14. Unless the Conciliation proceedings are terminated in terms of para 22 (b), (c) & (d) herein below, the IEC shall forward his/its recommendations as to possible terms of settlement within one (1) month from the date of last hearing. The date of first hearing of Conciliation shall be the starting date for calculating the period of 2 months.
15. In case of 3 members IEC, 2 members of IEC present will constitute a valid quorum for IEC and meeting can take place to proceed in the matter after seeking consent from the member who is not available. If necessary, videoconferencing may be arranged for facilitating participation of the members. However, the IEC recommendations will be signed by all members. Where there is more than one (1) Conciliator, as a general rule they shall act jointly. In the event of differences between the Members of IEC, the decision/recommendations of the majority of the Members of IEC shall prevail and be construed as the recommendation of the IEC.
16. The Draft Settlement Agreement prepared by the IEC in terms of the consensus arrived at during the Conciliation proceedings between the Parties shall be given by the IEC to both the parties for putting up for approval of their respective Competent Authority.
17. Before submitting the draft settlement agreement to BHEL's Competent Authority viz. the Board Level Committee on Alternative Dispute Resolution (BLCADR) for approval, concurrence of the other party's Competent Authority to the draft settlement agreement shall be obtained by the other party and informed to BHEL within 15 days of receipt of the final draft settlement agreement by it. Upon approval by the Competent Authority, the Settlement Agreement would thereafter be signed by the authorized representatives of both the Parties and authenticated by the members of the IEC.
18. In case the Draft Settlement Agreement is rejected by the Competent Authority of BHEL or the other Party, the Conciliation proceedings would stand terminated.
19. A Settlement Agreement shall contain a statement to the effect that each of the person(s) signing thereto (i) is fully authorized by the respective Party(ies) he/she represents, (ii) has fully understood the contents of the same and (iii) is signing on the same out of complete freewill and consent, without any pressure, undue influence.
20. The Settlement Agreement shall thereafter have the same legal status and effect as an arbitration award on agreed terms on the substance of the dispute rendered by an arbitral tribunal passed under section 30 of the Arbitration and Conciliation Act, 1996.
21. Acceptance of the Draft Settlement Agreement/recommendations of the Conciliator and/or signing of the Settlement Agreement by BHEL shall however, be subject to withdrawal/closure of any arbitral and/or judicial proceedings initiated by the concerned Party in regard to such settled issues.
22. Unless otherwise provided for in the agreement, contract or the Memorandum of Understanding, as the case may be, in the event of likelihood of prolonged absence of the Conciliator or any member of IEC, for any reason/incapacity, the Competent Authority/Head of Unit/Division/Region/Business Group of BHEL may substitute the Conciliator or such

Date :
Place:

Signature of the Bidder with seal
(Authorized Signatory)

member at any stage of the proceedings. Upon appointment of the substitute Conciliator(s), such reconstituted IEC may, with the consent of the Parties, proceed with further Conciliation into the matter either de-novo or from the stage already reached by the previous IEC before the substitution.

1. The proceedings of Conciliation under this Scheme may be terminated as follows:
 - a. On the date of signing of the Settlement agreement by the Parties; or,
 - b. By a written declaration of the IEC, after consultation with the parties, to the effect that further efforts at conciliation are no longer justified, on the date of the declaration; or,
 - c. By a written declaration of the Parties addressed to the IEC to the effect that the Conciliation proceedings are terminated, on the date of the declaration; or,
 - d. By a written declaration of a Party to the other Party and the IEC, if appointed, to the effect that the Conciliation proceedings are terminated, on the date of the declaration.
 - e. On rejection of the Draft Settlement Agreement by the Competent Authority of BHEL or the other Party.
2. The Conciliator(s) shall be entitled to following fees and facilities:

| SL. | Particulars | Amount |
|------------|---|---|
| 1 | Sitting fees | Each Member shall be paid a Lump Sum fee of Rs 75,000/- for the whole case payable in terms of paragraph No. 27 herein below. |
| 2 | Towards drafting of settlement agreement | In cases involving claim and/or counter-claim of up to Rs 5crores. Rs 50,000/- (Sole Conciliator) In cases involving claim and/or counter-claim of exceeding Rs 5 crores but less than Rs 10 crores. Rs 75,000 (per Conciliator) In cases involving claim and/or counter-claim of more than Rs 10 crores. Rs 1,00,000/- (per Conciliator) Note: The aforesaid fees for the drafting of the Settlement Agreement shall be paid on Signing of the Settlement Agreement after approval of the Competent Authority or Rejection of the proposed Settlement Agreement by the Competent Authority of BHEL. |
| 3 | Secretarial expenses | Rs 10,000/- (one time) for the whole case for Conciliation by a Sole Member IEC. Where Conciliation is by multi member Conciliators –Rs 30,000/- (one time)- to be paid to the IEC |
| 4 | Travel and transportation and stay at outstation i) Retired Senior Officials of other Public Sector Undertakings (pay scale wise equivalent to or more than E-8 level of BHEL) | As per entitlement of the equivalent officer (pay scale wise) in BHEL. |
| | Others | As per the extant entitlement of whole time Functional Directors in BHEL. Ordinarily, the IEC Member(s) would be entitled to travel by air Economy Class. |
| 5 | Venue for meeting | Unless otherwise agreed in the agreement, contract or the Memorandum of Understanding, as the case may be, the venue/seat of proceedings shall be the location of the concerned Unit / Division / Region / Business Group of BHEL. Without prejudice to the seat/venue of the Conciliation being at the location of concerned BHEL Unit / Division / Region / Business Group, the IEC after consulting the Parties may decide to hold |

Date :
Place:

Signature of the Bidder with seal
(Authorized Signatory)

| SL. | Particulars | Amount |
|------------|--------------------|--|
| | | the proceedings at any other place/venue to facilitate the proceedings. Unless, Parties agree to conduct Conciliation at BHEL premises, the venue is to be arranged by either Party alternately. |

3. The parties will bear their own costs including cost of presenting their cases/evidence/witness(es)/expert(s) on their behalf. The parties agree to rely upon documentary evidence in support of their claims and not to bring any oral evidence in IEC proceedings.
4. If any witness(es) or expert(s) is/are, with the consent of the parties, called upon to appear at the instance of the IEC in connection with the matter, then, the costs towards such witness(es)/expert(s) shall be determined by the IEC with the consent of the Parties and the cost so determined shall be borne equally by the Parties.
5. The other expenditures/costs in connection with the Conciliation proceedings as well as the IEC's fees and expenses shall be shared by the Parties equally.
6. Out of the lump sum fees of Rs 75,000/- for Sitting Fees, 50% shall be payable after the first meeting of the IEC and the remaining 50% of the Sitting Fees shall be payable only after termination of the conciliation proceedings in terms of para 22 hereinabove.
7. The travelling, transportation and stay at outstation shall be arranged by concerned Unit as per entitlements as per Serial No. 3 of the Table at para 23 above, and in case such arrangements are not made by the BHEL Unit, the same shall be reimbursed to the IEC on actuals limited to their entitlement as per Serial No. 4 of the Table at Para 23 above against supporting documents. The IEC Member(s) shall submit necessary invoice for claiming the fees/reimbursements.
8. The Parties shall keep confidential all matters relating to the conciliation proceedings. Confidentiality shall extend also to the settlement agreement, except where its disclosure is necessary for purposes of its implementation and enforcement or as required by or under a law or as per directions of a Court/Governmental authority/ regulatory body, as the case may be.
9. The Parties shall not rely upon or introduce as evidence in any further arbitral or judicial proceedings, whether or not such proceedings relate to the Disputes that is the subject of the Conciliation proceedings:
 - a. Views expressed or suggestions made by the other party in respect of a possible settlement of the Disputes;
 - b. admissions made by the other party in the course of the Conciliator proceedings;
 - c. proposals made by the Conciliator;
 - d. The fact that the other Party had indicated his willingness to accept a proposal for settlement made by the Conciliator.
10. The Parties shall not present the Conciliator(s) as witness in any Alternative Dispute Resolution or Judicial proceedings in respect of a Disputes that is/was the subject of that particular Conciliation proceeding.
11. None of the Conciliators shall act as an arbitrator or as a representative or counsel of a Party in any arbitral or judicial proceeding in respect of a Disputes that is/was the subject of that particular Conciliation proceeding.
12. The Parties shall not initiate, during the Conciliation proceedings, any arbitral or judicial proceedings in respect of a Disputes that is the subject matter of the Conciliation proceedings except that a Party may initiate arbitral or judicial proceedings where, in his opinion, such proceedings are necessary for preserving his rights including for preventing expiry of period of limitation. Unless terminated as per the provisions of this Scheme, the Conciliation proceedings shall continue notwithstanding the commencement of the arbitral or judicial proceedings and

Date :
Place:

Signature of the Bidder with seal
(Authorized Signatory)

the arbitral or judicial proceedings shall be primarily for the purpose of preserving rights including preventing expiry of period of limitation.

13. The official language of Conciliation proceedings under this Scheme shall be English unless the Parties agree to some other language.

Appendix I

**FORMAT FOR SEEKING CONSENT FOR REFERRING THE DISPUTES TO
CONCILIATION THROUGH IEC**

To,

M/s. (Stakeholder's name)

Sub: Resolution of the Disputes through conciliation by Independent Expert Committee (IEC).

Ref: Contract No/MoU/Agreement/LOI/LOA& date _____.

Sir,

With reference to above referred Contract/MoU/Agreement/LOI/LOA, you have raised certain Disputes/claims. Vide your letter dated____ you have requested BHEL to refer the Disputes/claims to IEC for Conciliation.

We are enclosing herewith Format (3) for giving consent and the terms and conditions of BHEL Conciliation Scheme, 2018 governing conciliation through IEC. You are requested to give your unconditional consent to the said terms and conditions of the Scheme by returning the same duly sealed and signed on each page. On receipt of your consent, matter will be put to the Competent Authority for consideration and decision.

Please note that BHEL has also certain claims against you (if applicable). BHEL reserves its right to agree or not to agree conciliation of the said disputes through BHEL and this letter is being issued without prejudice to BHEL's rights and contentions available under the contract and law.

Yours faithfully,

Representative of BHEL

Date :
Place:

Signature of the Bidder with seal
(Authorized Signatory)

**FORMAT FOR GIVING CONSENT BY CONTRACTOR /VENDOR/ CUSTOMER/
COLLABORATOR /CONSORTIUM PARTNERS FOR REFERRING THE DISPUTES TO
CONCILIATION THROUGH IEC**

To,

BHEL

.....

Sub: Resolution of Disputes through Conciliation by Independent Expert Committee (IEC).
Ref: Contract/MoU/Agreement/LOI/LOA No _____ & date_____

With reference to above referred contract, our following bills/invoices/claims submitted to BHEL are still unpaid giving rise to Disputes:

| SL. no. | Claim Description | Bill submitted to BHEL (no. and date) | Amount of the bill/claim | Amount received from BHEL | Outstanding Amount |
|---------|-------------------|---------------------------------------|--------------------------|---------------------------|--------------------|
| | | | | | |
| | | | | | |
| | | | | | |

Accordingly we request you to kindly refer the Disputes in respect of above claims to IEC for Conciliation.

We hereby agree and give our unconditional consent to the terms and conditions of BHEL Conciliation Scheme, 2018 governing conciliation through IEC. We have signed the same on each page and enclosed it for your consideration.

Yours faithfully,

(Signature with stamp)
Authorized Representative of Contractor
Name, with designation Date

Appendix III

**STATEMENT OF CLAIMS/COUNTER CLAIMS TO BE SUBMITTED TO THE IEC BY
BOTH THE PARTIES**

1. Chronology of the Disputes
2. Brief of the Contract/MoU/Agreement/LOI/LOA
3. Brief history of the Disputes:
4. Issues:
5. Details of Clam(s)/Counter Claim(s):

| SI. No. | Description of claim(s)/Counter Claim | Amount (in INR)Or currency applicable in the contract | Relevant contract clause |
|---------|---------------------------------------|---|--------------------------|
| | | | |
| | | | |
| | | | |

Basis/Ground of claim(s)/counter claim(s) (along with relevant clause of contract)

Note– The Statement of Claims/Counter Claims may ideally be restricted to maximum limit of 20 pages. Relevant documents may be compiled and submitted along with the statement of Claims/Counter Claims. The statement of Claims/Counter Claims is to be submitted to all IEC members and to the other party by post as well as by email.

Date :
Place:

Signature of the Bidder with seal
(Authorized Signatory)

ANNEXURE-T4

GENERAL TERMS AND CONDITIONS OF THE CONTRACT

1. DEFINITION: - IN THESE GENERAL CONDITIONS OF CONTRACT, THE FOLLOWING TERMS SHALL HAVE THE MEANING HEREBY ASSIGNED TO THEM, EXCEPT WHERE THE CONTEXT OTHERWISE REQUIRES: -

- 1.1 The "Contract" means, the documents forming the tender and acceptance thereof, together with all the documents referred to therein including general and special conditions to contract. All these documents as applicable taken together shall be deemed to form one contract and shall be complementary to one another.
- 1.2 The "work" means, the analytical work described in the tender documents.
- 1.3 The "contractor/ bidder" means, the individual Firm or Company whether incorporated or not, undertaking the work and shall include the legal personal representatives of such individuals or the persons composing the firm or Company or the successors of the firm or company and the permitted assigns of such individual or firm or Company.
- 1.4 "The Officer-In charge/ Lab-in-charge" means, the Officer deputed by the HEAD / NGA, WRI& Labs to supervise the work or part of the work.
- 1.5 "Approved" and "Directed" means, the approval or direction of HOD/WCM, or person deputed by him for the particular purposes.
- 1.6 "BHARAT HEAVY ELECTRICALS LIMITED" (herein after referred to as BHEL) shall mean the Board of Directors, Chairman, Executive Director, General Manager or other Administrative Officer of the said Company including SM/WCM authorized to invite tenders and enter into contract for works on behalf of the Company.
- 1.7 The "Contract sum" means, the sum accepted or the sum calculated in accordance with the prices accepted in tender and / or the contract rates as payable to the contractor for the execution of the work during the currency of the contract.
- 1.8 A "week" means, Seven Days, without regard to the number of hours worked or not worked in any day in that week.
- 1.9 A "day" means, the day of 24 hours (TWENTY-FOUR) irrespective of the number of hours worked or not worked in that day.
- 1.10 A "working day" means, any day other than that prescribed by the NEGOTIABLE INSTRUMENTS ACT as being a Holiday, and consists of the number of hours of labour as commonly recognized by good employers in the trade in the district where the work is carried out or as laid down in the BHEL regulations.

2. HEADING TO THE CONTRACT CONDITIONS: -

- 2.1 The heading to these conditions shall not affect the interpretations thereof.

3. WORK TO BE CARRIED OUT: -

- 3.1 The Contractor will be deemed to have satisfied himself as to the nature of the site, local facilities of access and all matters affecting the execution of the work. No extra charges consequent on any misunderstanding in these respects or otherwise will be allowed.

Date :
Place:

Signature of the Bidder with seal
(Authorized Signatory)

4. DEVIATIONS: -

4.1 The contractor shall not carry out any work not covered by schedule except in pursuance of the written instructions of an executive not below the rank of DGM of WCM / end user. No such work shall be valid unless the same has been specifically confirmed and accepted by BHEL in writing and incorporated in the Contract.

5. ASSIGNMENT OF TRANSFER OF CONTRACT: -

5.1 The Contractor shall not without the prior written approval of the BHEL, assign or transfer the contract or any part thereof, or any share, or interest thereon to any other persons. No sum of money which may become payable under the contract shall be payable to any person, other than the contractor unless the prior written approval of the BHEL to the assignment or transfer of such money is given.

5.2 **SUB-CONTRACT: -** The Contractor shall not sub-let any portion of the contract.

6. COMPLIANCE TO REGULATIONS AND BY-LAWS: -

6.1 The Contractor shall confirm to the provisions of any statute relating to the work and regulations and Bye-Laws of any local authority. The Contractor shall be bound to give all notices required by statute regulations or By-Laws as aforesaid and to pay all fees and taxes payable to any authority in respect thereof.

7. SECURITY DEPOSIT: -

7.1 BHEL shall not be responsible for any loss of securities, due to liquidation for any other reasons, what-so-ever or any depreciation in the value of the securities while in their charge or for any loss of interest there on.

7.2 All compensation or other sums of money payable by the Contractor to BHEL under the terms of this contract or under any other contract with BHEL may be deducted from the Security Deposit or realised by the sale of the securities or from the interest arising therefrom or from any sums which may be due or may become due to the contractor by BHEL and in the event of this Security Deposit being deducted by reason of such deductions or sale, as aforesaid, the Contractor shall within 7 days thereafter, make good in cash or in securities endorsed as aforesaid, any sum by which the Security Deposit has been reduced.

8. REFUND OF SECURITY DEPOSIT: -

8.1 Security Deposit will be refunded on completion of the work and after the expiry of the maintenance period, if any, provided always that the Contractor shall first have been paid the last and final bill and have rendered a "NO DEMAND CERTIFICATE". In case no maintenance period is applicable, then 100% of security Deposit will be refunded after providing "NO DEMAND CERTIFICATE" by the contractor as per format provide by BHEL

9. ORDERS UNDER THE CONTRACT: -

9.1 All orders, notices etc. to be given under the contract shall be in writing, type-script or printed and if sent by registered post to the address given in the Tender of the Contract, shall be deemed to have been served on the date, when in the ordinary course they would have been delivered to him. The Contractor shall carry out without delay all orders given to him. Contractor shall be deemed to have included in his tender price of all the plant, machinery and appliances required for the purpose of all operations connected with the work embraced under the contract to secure a satisfactory quality of work and rate of progress which in the opinion of the " Contract Signing Officer" will ensure the completion of the work within the time specified. BHEL is having every right to split the schedule and to award the work to single or many parties on the lowest offered rates basis. This is a time bound contract for period mentioned, and does not envisage any extension of time / period.

Date :
Place:

Signature of the Bidder with seal
(Authorized Signatory)

10. CONTRACTOR'S SUPERVISION: -

- 10.1 The contractor shall either himself supervise the execution of the contract or shall appoint a competent agent acceptable to BHEL Officials.
- 10.2 Orders given to the contractor's agent shall be considered to have the same force as if they have been given to the contractor himself.
- 10.3 The contractor or his accredited agent shall attend when required without making any claim for doing so to the Executive/WCM or OFFICER-INCHARGE, to receive instructions.
- 10.4 The respective area HOD have full powers and without assigning any reason, require the contractor to immediately cease to employ in connection with this contract, any agent, servant or employee where continued employment is, in his opinion undesirable. The contractor shall not be allowed any compensation on this account.

11. LABOUR

- 11.1 The Contractor shall remain liable for the payment of all wages or other moneys to his work-people or employees under the payment of Wages Act 1936, Employees Liability Act. 1938, Workmen's Compensation Act 1923 or any other Act or enactment, relating thereto and rules framed, there under from time to time.

12. PRECAUTIONS AGAINST RISK: -

- 12.1 The Contractor shall be responsible for providing at his own expense for all precautions to prevent loss or damage from any and all risks and to minimize the amount of any such loss or damage and for the necessary steps to be taken for the said purpose.

13. DAMAGE & LOSS TO PRIVATE PROPERTY & INJURY TO WORKMEN: -

- 13.1 The Contractor shall at his own expense reinstate and make good to the satisfaction of the respective area HOD and pay compensation for any injury, loss or damage occurred to any property or rights whatever including property and rights of BHEL (or agents) servants or employee of BHEL, the injury loss or damage arising out of or in any way in connection with the execution or purported execution of the contract and further the contractor shall indemnify, the BHEL against all claims enforceable against BHEL (or any agent, servant or employee of BHEL) or which would be so enforceable against BHEL where BHEL is a private person, in respect of any such injury (including injury resulting in death) loss or damage to any person whomsoever or property including all claims which may arise under the Workmen's Compensation Act or otherwise.

14. LAWS GOVERNING THE CONTRACT: -

- 14.1 The contract shall be governed by the Indian Laws for time being in force.

15. CANCELLATION OF CONTRACT FOR CORRUPT ACTS: -

- 15.1 BHEL, whose decision shall be final and conclusive, shall without prejudice to any other right or remedy which shall have accrued shall accrue thereafter to BHEL cancel the contract in any of the following cases and the Contractor shall be liable to make payment to BHEL for any loss or damage resulting from any such cancellation to the same extend as provided in the case of cancellation for default.

If the Contractor shall: -

- 15.2 Offer or give or agree to give to any person in BHEL service any gift or consideration of any kind, as an inducement or reward for doing or for bearing to do or for having done or for borne to do any act, in relation to the obtaining or execution of this or any other contract for BHEL service,

Date :
Place:

Signature of the Bidder with seal
(Authorized Signatory)

OR

15.3 enter in to a contract with BHEL in connection with which commission has been paid or agreed to be paid by him or with his knowledge, unless the particulars of any such commission and the terms of payment thereof have previously been disclosed in writing to BHEL.

OR

15.4 obtain a contract with BHEL as a result of ring tendering or by non-bonafide methods of competitive tendering, without first disclosing the fact in writing to BHEL.

16. CANCELLATION OF CONTRACT FOR INSOLVENCY ASSIGNMENT OF TRANSFER OR SUB-LETTING OF CONTRACT: -

BHEL, without prejudice to any other right or remedy which shall have accrued or shall accrue thereafter to BHEL shall cancel the contract in any of the following cases:

If the Contractor,

16.1 being an individual or if a firm any partner thereof shall at any time be adjudged bankrupt or have a receiving order for administration of his estate, made against him or shall take any proceedings for liquidation or composition under any bankruptcy Act or assignment of his effects of composition or arrangement for the benefit of his creditors or purport to do so, or if any application made under any Bankruptcy Act for the time being in force for the sequestration of his estate or if a trust deed be granted by him on behalf of his creditors

OR

16.2 being a Company, shall pass a resolution or the Court shall make an order for the liquidation of its affairs, or a receiver or Manager on-behalf of the debenture holders shall be appointed or circumstances shall arise which entitle the Court or debenture holders to appoint a receiver or Manager,

16.3 Assigns, Transfers, Sub-lets or attempts to assign, transfer or sub-let any portion of the work.

16.4 Whenever BHEL exercise the authority to cancel the contract under this conditions, BHEL may have the work done by any means at the Contractor's risks and expenses provided always that in the event of the cost of the work so done (as certified by an Executive not below the rank of DGM of WCM / end user which is final and conclusive) being less than the contract cost, the advantage shall accrue to the BHEL and if the cost exceeds the money due to Contractor under the contract, the Contractor shall either pay the excess amount ordered by the Executive not below the rank of DGM of WCM / end user, or the same shall be recovered from the Contractor by other means.

16.5 In case the BHEL carries-out the work under the provisions of this condition the cost to be taken into account in determining the excess cost to be charged to the Contractor under this condition shall consist of the cost of the materials, hire charges of tools and plants and/or labour provided by the BHEL with an addition of such percentage to cover superintendence and establishment charges as may be decided by the Executive not below the rank of DGM of WCM / end user, whose decision shall be final and conclusive.

17. CANCELLATION OF CONTRACT IN PART OF FULL FOR CONTRACATOR'S DEFAULT:

If the Contractor:

17.1 Makes default in carrying out the work as directed and continues in that state after a reasonable notice from the Executive not below the rank of DGM of WCM / end user, or his authorized representative;

17.2 Fails to comply with any of the Terms and Conditions of the contract or after reasonable notice in writing with orders properly issued thereunder;

Date :
Place:

Signature of the Bidder with seal
(Authorized Signatory)

17.3 BHEL, may without prejudice to any other right or remedy which shall have accrued or shall accrue thereafter to BHEL CANCEL the contract as whole or in part thereof or only such work order or items of work in default from the contract. Whenever BHEL exercise the authority to cancel the contract as whole or part under this condition BHEL may complete the work at the contractor's risk and cost (as certified by the Executive not below the rank of DGM of WCM / end user, which is final and conclusive) being less than the contract cost, the advantage shall accrue to the BHEL. If the cost exceeds the moneys due to the Contractor under this contract the Contractor shall either pay the excess amount ordered **by the Executive not below the rank of DGM of WCM / End user** or the same shall be recovered from the Contractor by other means. In case the BHEL carries out the work or any part thereof under the provisions of the conditions the cost to be taken into account in determining the excess cost to be charged to the Contractor under this condition shall consist of the cost of the materials, hire charges of tools and plant and/or labour provided by the BHEL with an addition of such percentage to cover the superintendence and establishment charges as may be decided by the Executive not below the rank of DGM of WCM / end user, whose decision shall be final and conclusive.

18. TERMINATION OF CONTRACT ON DEATH OF CONTRACTOR. :-

18.1 Without prejudice to any of the rights or remedies under this contract, if the Contractor dies, or if the firm is dissolved or the company is liquidated, BHEL shall have the option of terminating the contract without compensation to the Contractor.

19. SPECIAL POWER TO TERMINATION: -

19.1 If at any time after the award of contract, BHEL shall for any reason whatsoever does not require whole or any part of the work to be carried out, then Head of WCM shall give notice in writing of the fact to the Contractor and terminate the contract. The contractor shall have no claim to any payment of compensation or otherwise howsoever on account of any profit or advantage which he might have derived from the execution of the work in full but which he did not derive in consequence of the fore-closing of the work.

20. RECOVERY FROM CONTRACTOR: -

20.1 Whenever under the contract, any sum of money, shall be recoverable from or payable by the Contractors, the same may be deducted from or any sum then due or which at any time thereafter may become due to Contractor under the contract or under any other contract with BHEL or from his Security Deposit or he shall pay the claim on demand.

21. POST TECHNICAL AUDIT OF WORK AND BILLS: -

21.1 BHEL reserves the right to carry out the post-payment Audit and technical examination of the work and final bill including all supporting vouchers, abstracts etc., and enforce recovery of any sum becoming due as a result thereof in the manner provided in the presiding sub-paragraphs. However, no such recovery shall be enforced after three years of passing the final bill.

22. SIGNING OF CONTRACT: -

22.1 Each contract document shall be signed by the Contractor with his usual signature. Contract by partnership of Hindu Joint Family firm, may be signed in the FIRM'S name by one of the Partners or the Karta or Manager as the case may be or by any other duly authorised representative followed by the name and designation of the persons so signing. Contracts by a Company shall be signed with the name of the Company by a person authorised in this behalf and a power of attorney or other satisfactory proof showing that the persons signing the Contract documents on behalf of the Company is duly authorised to do so, shall accompany the contract.

Date :
Place:

Signature of the Bidder with seal
(Authorized Signatory)

23. STATUTORY REQUIREMENTS:

- 23.1 All statutory requirements under Minimum Wages Act,1948, Factories Act 1948, Workmen Compensation Act 1923, Employees Provident Fund and Miscellaneous Provisions Act 1952, Payment of Gratuity Act 1972, Employee State Insurance Act 1948, Contract Labour (R&A) Act 1970, Payment of Bonus Act 1965, Income Tax Act, GST Act and all other applicable Acts shall be complied with by the Contractor.
- 23.2 Contractor shall comply with all statutory requirements, rules, regulations, notifications in relation to employment of his employees issued from time to time by the concerned authorities.
- 23.3 Contractor shall indemnify BHEL against all claims and losses under various Labour Laws, statutes or any civil or criminal law in connection with employees deployed by him.
- 23.4 Contractor wherever applicable shall maintain proper records prescribed by the concerned statutory authorities and provide a copy of the same to BHEL.
- 23.5 Contractor shall furnish proper returns to the concerned statutory authorities and provide a copy of the same to BHEL.

24. REGISTERS & RECORDS: -

- 24.1 The Contractor shall maintain all registers and records in the proper manner and as required by the regulations of the various authorities concerned and indemnify the Employer from the consequences due to any inaccurate or faulty documentation on the part of the Contractor.

25. REMOTE TRANSACTIONS: -

- 25.1 The Contractor shall agree to and comply with all such terms and conditions as BHEL may prescribe from time to time and shall confirm that all transactions effected by or through facilities for conducting remote transactions including the Internet, World Wide Web, electronic data interchange, call centers, teleservice operations (whether voice, video, data or combination thereof) or by means of electronic, computer, automated machines network or through other means of telecommunication established by BHEL shall constitute legally binding and valid transactions when done.

26. CHANGE IN CONSTITUTION OF FIRM: -

- 26.1 Changes in constitution of firm whenever it is made after submission of application or during currency of the contract, the existing firm has to duly inform the proposed changes to contracting department of BHEL at the appropriate time before the changes in the constitution are made. In case the absence of any such information BHEL is not responsible for the consequences arising out of the absence or suppression of information and the issue / dispute arising out of these changes and the firm is responsible for settling the issue or dispute among themselves (Partners etc) or with the bankers or with any third party. Under the above circumstances when dispute arises and the firm does not inform the change in the constitution of the firm BHEL may reserve its rights for suspending or terminating the contract.

Date :
Place:

Signature of the Bidder with seal
(Authorized Signatory)

ANNEXURE-T5**PRE-QUALIFYING REQUIREMENTS (PQR)****IMPORTANT CONDITIONS**

The Bidders must comply with all the PQR mentioned below. Noncompliance of any one of the PQR will lead to total rejection of the offer submitted by the bidders, who are not complying with the PQR, in full.

All the supporting documents enclosed shall be duly self-attested by the bidder concerned.

All the information furnished / supporting documents enclosed by the bidders will be considered as authentic for evaluation of Bid. If any information furnished / supporting documents attached are subsequently found to be incorrect / fraudulent / forged, at any later date or during the tenure of the Contract, it will be viewed seriously and suitable penal action (viz., delisting, termination of the bidder from Contract, legal action, forfeiture of EMD / SD etc.,) will be initiated against such bidders as per the Rules and Guidelines prevailing in BHEL.

BHEL reserves the right to visit the vendor's works if required for verifying the credential furnished by the vendor. In case the information furnished along with the offers is found to be false/incorrect, the offer shall be rejected.

1. ORGANIZATION/FIRM REGISTRATION

1.1 Only registered / licensed companies / firms / proprietors / partnerships, will be eligible for participating in this Tendering Process. Wherever "Companies Act 1956" is applicable the Company shall be registered in line with "Companies Act 1956".

1.2 Documents to be submitted: The details of the registration Documents to be submitted are below: -

| SL | Type of Organisation | Documents to be submitted (Self-Attested) |
|----|----------------------------|---|
| 1 | Sole Proprietorship | Trade License / GST registration / Auditor's letter |
| 2 | Partnership | Partnership Deed Copy of Extract from Register of Firms showing latest constitution of Firm (Form A /G/any other form as the case may be) , Trade License / GST Certificate and PAN |
| 3 | Unregistered Partnership | Partnership Deed, Notarized Declaration as to the constitution of Firm signed by all the Partners and Trade License , GST Certificate and PAN |
| 4 | Private Limited Company | Certificate of Registration/Memorandum of Association & Articles of Association |
| 5 | Public Limited Company | Certificate of Registration/Memorandum of Association & Articles of Association |
| 6 | Public Sector / Govt. org. | Certificate of Registration/Memorandum of Association & Articles of Association |

2. PERMANENT ACCOUNT NUMBER (PAN):

2.1 Bidder should have valid Permanent Account Number (PAN) and Self-Attested copy of PAN Card shall be enclosed.

3. GST REGISTRATION NUMBER:

3.1 The bidder shall be possessing GST Certificate. The copy of GST certificate shall be enclosed.

Date :
Place:

Signature of the Bidder with seal
(Authorized Signatory)

4. POWER OF ATTORNEY:

- 4.1 The tender documents should be signed by authorized signatory. Authorized signatory shall be the person holding 'power of attorney' on behalf of the firm/company/bidder-concerned authorized/empowered to act on behalf for the specific purpose.
- 4.2 BHEL will not be bound by any other Power of Attorney granted or the change in the composition of the firm made, subsequent to the execution of the Contract agreement. They may however recognize such Power of Attorney or change in status after obtaining legal advice and the cost involved in that connection shall be chargeable to the bidder concerned
- 4.3 **Documents to be submitted:** A self-attested copy of the Power of Attorney, in case an individual/authorized signatory other than the sole proprietor signs the tender shall be submitted along with the tenders.

5. PREVIOUS EXPERIENCE

- 5.1 OEM Vendors who have manufactured and supplied CCOE(PESO) approved cryogenic liquid vessel(LAR/LOX/LIN/LNG) of minimum 10KL capacity.

OR

- 5.2 Vendors who have installed CCOE(PESO) approved cryogenic liquid vessel (LAR/LOX/LIN/LNG) of minimum 10KL capacity on rental basis for at least to two companies in the past seven years from the date of tender opening for which required purchase order/work order copies are to be submitted along with the offer.

5.3 Documents to be submitted

- 5.3.1 Experience proof from BHEL shall contain work order copies and experience proof from other than BHEL shall contain work order / Documentary evidence (WO /Agreement/ Completion certificate) copy to be uploaded in GeM Portal)
- 5.3.2 Above experience other than BHEL to be supported by TDS (Tax Deducted at Source) certificate issued by the organization OR Form 26 AS OR Bank statement for transaction of payment.

6. NO DEVIATION DECLARATION

- 6.1 The Bidder should furnish and enclose the "No Deviation Declaration" as per Proforma-1

7. CORRIGENDUM (IF ANY)

- 7.1 Corrigendum issued by BHEL if any shall be enclosed.

8. STATEMENT FOR EVALUATION ON PQR

- 8.1 The Bidder shall furnish the following table.

Date :
Place:

Signature of the Bidder with seal
(Authorized Signatory)

STATEMENT FOR EVALUATION ON PQR
(to be filled and uploaded in GeM Portal)

Important: All the points of the statements to be adequately substantiated invariably with documentary proof thereto. Non-compliance of this requirement shall be deemed fit to reject the offers.

| SL | Description | Details (Write / Tick as applicable) |
|-----|--|---|
| 1 | Registered Name of the Bidder | |
| 1.1 | Contact Details | Address: Contract Person Name:..... Designation: Mobile No: Land Line Number: Email ID-1:..... Email ID-2: |
| 2.1 | MSE Details | UDYAM Registration Certificate Number : Date : MSE Status |
| 3 | Type of Company | <input type="checkbox"/> Sole Proprietorship <input type="checkbox"/> Partnership <input type="checkbox"/> Unregistered Partnership <input type="checkbox"/> Private Limited Company <input type="checkbox"/> Public Limited Company <input type="checkbox"/> Public Sector / Govt. org. |
| 3.1 | Company Registration Number & Date | |
| 3.2 | Type of Proof Enclosed | |
| 4 | Power of Attorney | <input type="checkbox"/> Enclosed, <input type="checkbox"/> Not Enclosed |
| 5.2 | Income Tax Permanent Account Number (PAN) | PAN No..... |
| 5.3 | GST Registration | GST Registration No. |
| 5.4 | GST % quoted | % |
| 6 | Previous Experience Proof | <input type="checkbox"/> Enclosed, <input type="checkbox"/> Not Enclosed |
| 7 | No Deviation Declaration | <input type="checkbox"/> Enclosed, <input type="checkbox"/> Not Enclosed |
| 9 | Corrigendum, if any | <input type="checkbox"/> Enclosed, <input type="checkbox"/> Not Enclosed, <input type="checkbox"/> Not Applicable |
| 10 | At the time of award of Contract, the service provider has to have PF and Group Insurance covered for his employees. | <input type="checkbox"/> Agreed, <input type="checkbox"/> Not Agreed |

Date :
Place:

Signature of the Bidder with seal
(Authorized Signatory)

NO DEVIATION DECLARATION

GeM Bid Ref: GEM/2023/B/4211114

I/We, have read and clearly understood all the Terms and conditions in Tender Schedule of and accordingly accept the same without any deviation what so ever.

I/ We unconditionally agree to all the tender conditions and no new conditions are imposed by us in the technical / price bid. I understand in the event of imposing any condition in the technical / price bid, such condition would be ignored by BHEL and only the prices will be considered for the purpose of evaluation”

I/ We confirm that none of our group concern or affiliates etc., appears on the list of banned firms / companies by BHEL (list available on www.bhel.com) nor any of the Director / Partner / proprietor of bidder / such group concern or affiliate etc. are involved with such company.

I/ We also declare that, we have not been suspended or black listed or issued with Show Cause Notice by BHEL- Trichy or any other BHEL Unit or any PSU/ Government organization.

I/ We confirm that other than us, none of our group concerns or affiliates etc. are participating in the tender either directly or indirectly through any other agency under same proprietor / common director(s) / common partner(s).

I/ We confirm that if any of the above statement / information furnished by us in this tender is found to be false/ fake at any stage of tender evaluation or during execution of contract, BHEL will have the right to initiate appropriate action including legal proceeds / termination of contract, recovery of damages, penalties etc. as deemed fit.

I/ We will not enter into any illegal or undisclosed agreement or understanding, whether formal or informal with other Bidder(s). This applies in particular to prices, specifications, certifications, subsidiary contracts, submission or non-submission of bids or any other actions to restrict competitiveness or to introduce cartelization in the bidding process

I/ We undertakes that, I/We had never been found guilty by a court of law in India for any offence involving fraud, dishonesty and moral turpitude. If at a later date, if it comes to the notice of BHEL about any such occurrences on the subject bidder, BHEL will have every right to reject the offer of such vendors at any point of time.

Yours Sincerely,

Signature of the Bidder with date & Seal

Date :
Place:

Signature of the Bidder with seal
(Authorized Signatory)

PART-2

PRICE BID

(Vendor to quote the price GeM portal)

1. WORK / RATE SCHEDULE

| Item SL. | Scope | Duration | Total Value for 24 Months including GST |
|--|---|-----------|--|
| 10 | <p><u>FIXED FACILITY CHARGES FOR LOX-UNIT 1</u> Supply, Installation and Maintenance charges for Liquid Oxygen vessel with Thermos Siphon provision for cylinder filling purpose and their accessories / facilities on Rental/Hired Basis which are to be located at Bldg.12, BHEL, Trichy (Unit-1) comprising of the following for a period of two years.</p> <p>1) 13 KL, 17 kg/cm²(g) vacuum insulated Liquid Oxygen Cryogenic storage tank with thermo-siphon system- 1No. 2) Low Pressure Vaporiser system (400 Nm³/hr capacity for line distribution) -1No. 3) Pressure regulating station (400 Nm³/hr capacity for line distribution) with safety valves- 1 Set. 4) Piping and fittings for interconnecting above equipment- 1 Set.</p> <p>DETAILED TECHNICAL PART AS PER ANNEXURE-T3, Clause-1.1.</p> | 24 Months | < to be filled in GeM portal only> |
| 20 | <p><u>FIXED FACILITY CHARGES FOR LOX-UNIT 2</u> Supply, Installation and Maintenance charges for liquid oxygen vessel and their accessories / facilities on Rental/Hired Basis which are to be located at Unit-II, BHEL, Trichy comprising of the following for a period of two years.</p> <p>1) 13 KL, 17 kg/cm²(g) vacuum insulated liquid oxygen cryogenic storage tank with their accessories - 1 No. 2) Low Pressure Vaporiser system (400 m³/hr capacity for line distribution) - 1No. 3) Pressure regulating station (400 Nm³/hr capacity for line distribution) with safety valves - 1 Set. 4) Piping and fittings for interconnecting above equipment - 1 Lot</p> <p>DETAILED TECHNICAL PART AS PER ANNEXURE-T3, Clause-1.2.</p> | 24 Months | < to be filled in GeM portal only> |
| Item SL. | Scope | Qty | Lumpsum Rate including GST |
| 30 | <p><u>MOBILISATION, ERECTION AND COMMISSIONING CHARGES - UNIT-I</u> Mobilisation, Erection and Commissioning of the LOX vessel with accessories said in Item-10, if applicable.</p> | Lumpsum | < to be filled in GeM portal only> |
| 40 | <p><u>MOBILISATION, ERECTION AND COMMISSIONING CHARGES - UNIT-II</u> Mobilisation, Erection and Commissioning of the LOX vessel with accessories said in Item-20, if applicable.</p> | Lumpsum | < to be filled in GeM portal only> |
| TOTAL (L1 Vendor will be identified based on this total value only. i.e. =sum of {quantity x rates quoted} for respective Item) | | | |

Date :
Place:Signature of the Bidder with seal
(Authorized Signatory)

2. IMPORTANT INSTRUCTION

- 2.1 Rate will be considered up to TWO (02) decimal points only (i.e., XX.XX). Digit beyond two decimal points will be ignored and not rounded off. No representation on this account will be entertained.
- 2.2 The rate offered shall provide for the complete cost towards labour, supervision, profits & overheads, and all other incidentals inclusive of applicable GST (As per BOQ), GST will be reimbursed on production of valid documentary proof for having paid the GST.
- 2.3 Layout Drawing is attached.

Date :
Place:

Signature of the Bidder with seal
(Authorized Signatory)

BHE:CP:01:386/09
04
DRAWING NO.

ALL DIMENSIONS ARE IN MILLIMETERS

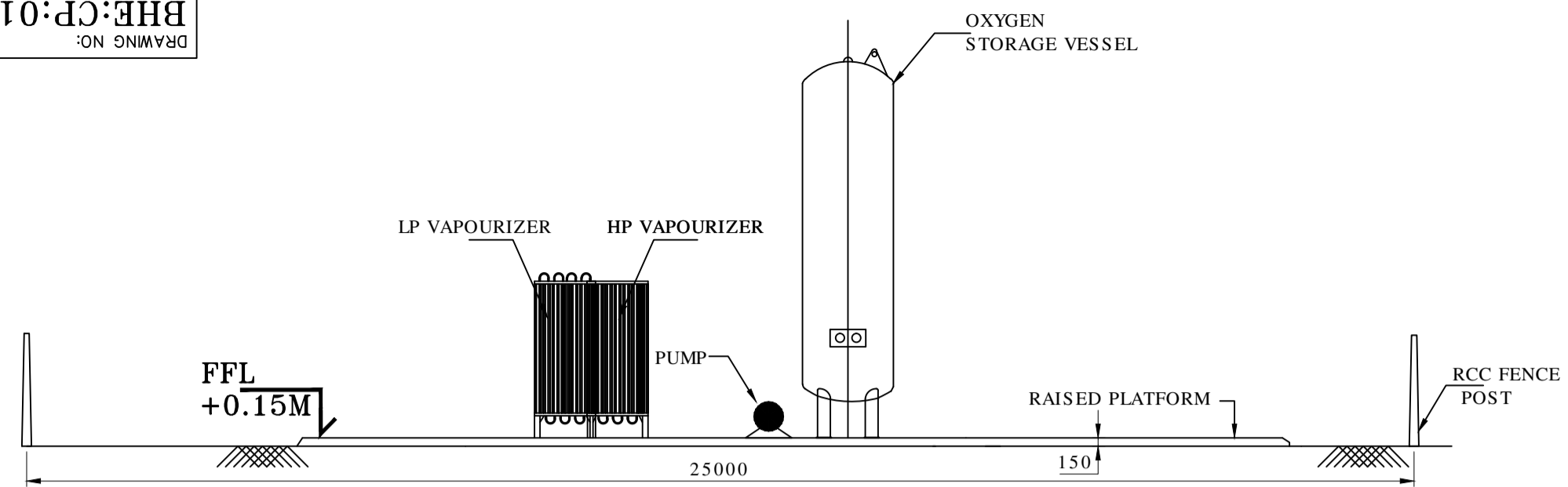

ELEVATION-BB

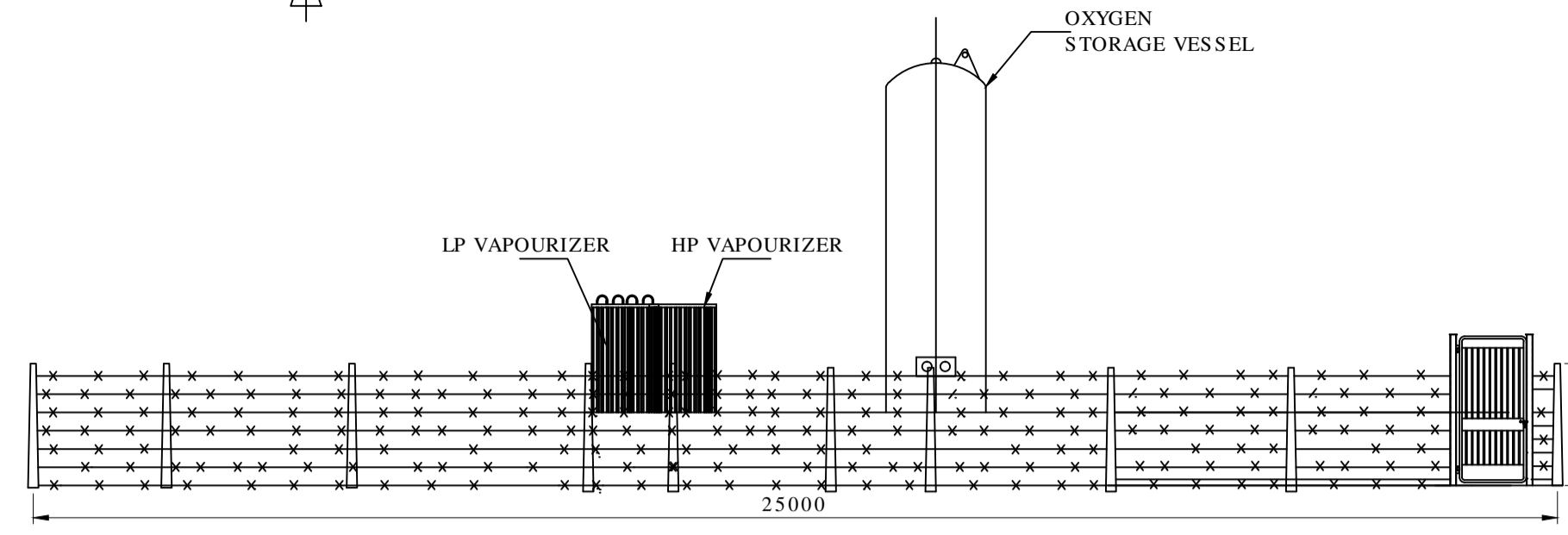

ELEVATION-AA

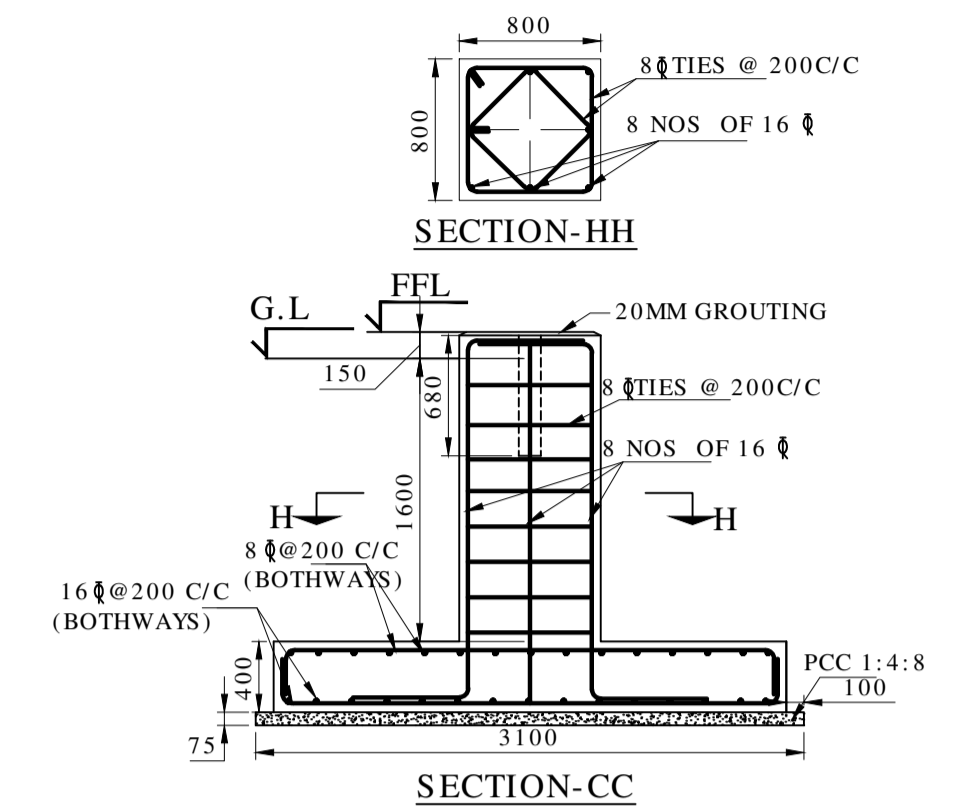

SECTION-HH

SECTION-CC

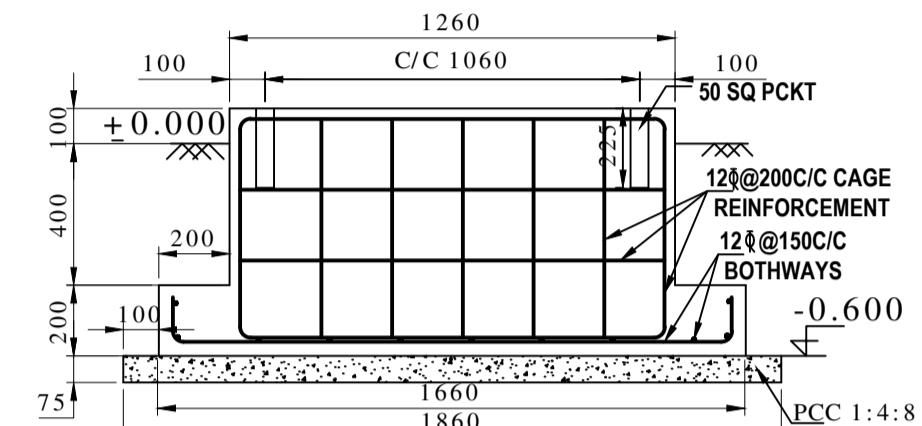

SEC Z-Z

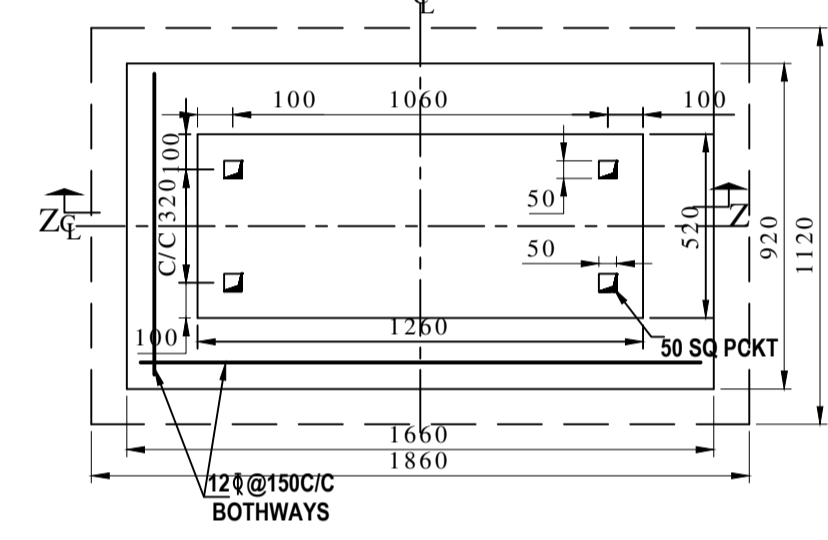

PLAN OF CRYOPUMP

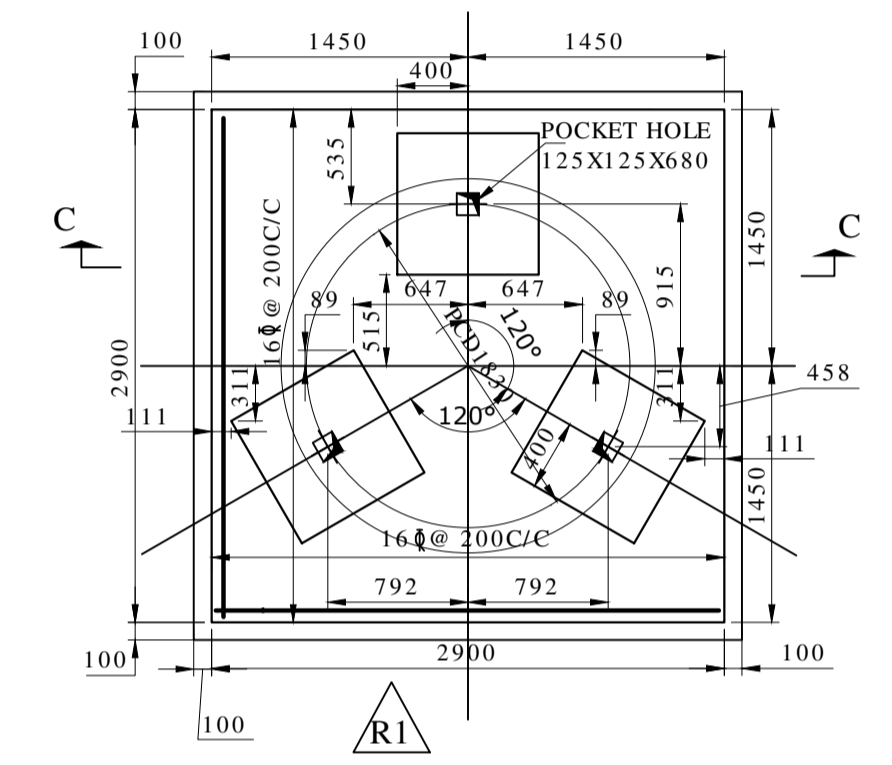

PLAN OF OXYGEN STORAGE VESSEL FOUNDATION

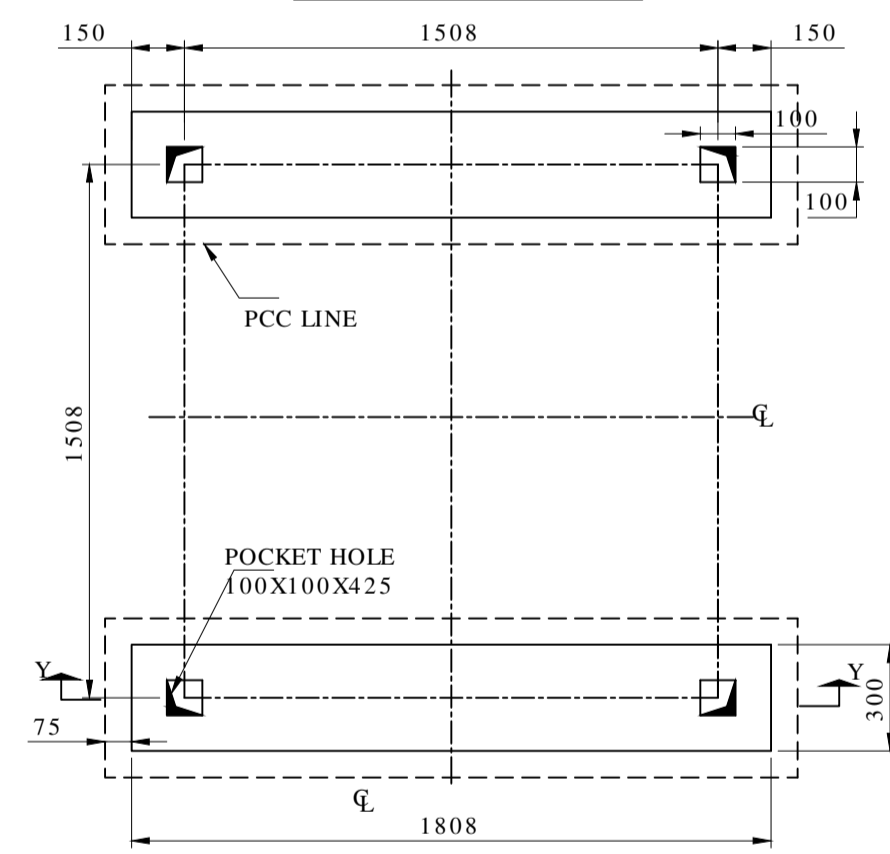

PLAN OF LP VAPOURIZER FOUNDATION

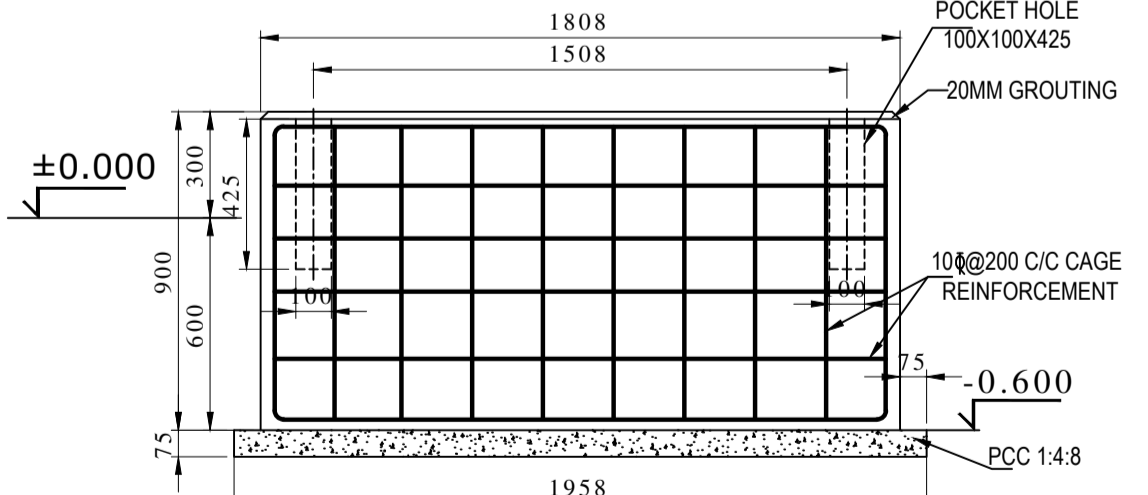

SECTION-YY

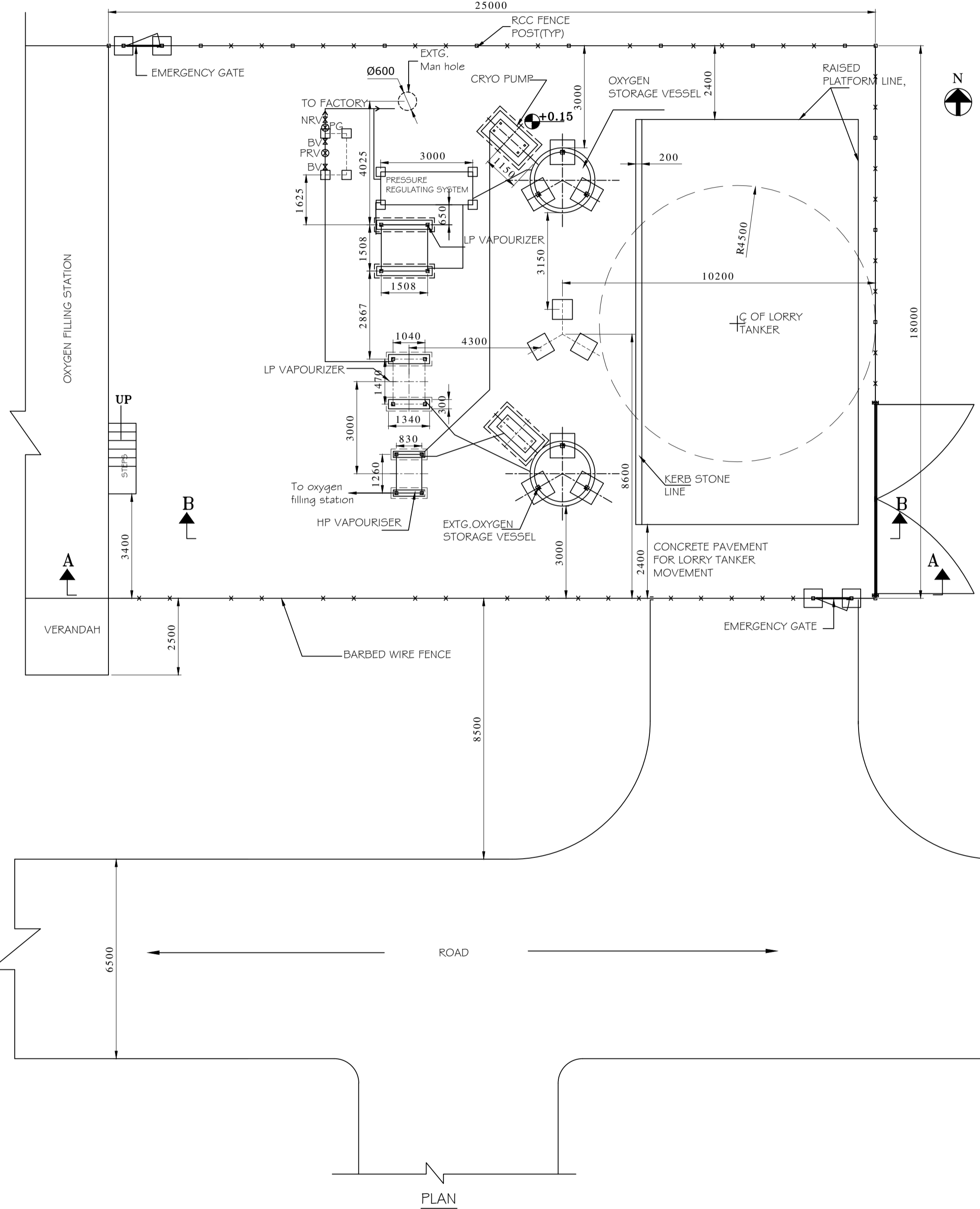

PLAN

NOTES:-

- 1) ALL DIMENSIONS ARE IN 'MM' & LEVELS ARE IN 'M'
- 2) CLEAR COVER TO REINFORCEMENT IS 40MM FOR ALL SIDE
- 3) CONCRETE GRADE M20
- 4) ALL REINFORCEMENT BARS SHALL BE HIGH YIELD STRENGTH DEFORMED BARS CONFORMING TO IS: 1786-(LATEST REVISION)
- 5) DEVELOPMENT LENGTH $L_d = 50$ TIMES THE DIA OF THE BAR
- 6) IF SOIL AT FOUNDING LVL IS LOOSE EXTRA EXCAVATION TO BE CARRIED OUT TILL HARD STRATA AND EXTRA EXCAVATED PORTION TO BE FILLED WITH PCC
- 7) BASE PLATE & FOUNDATION BOLTS ARE IN THE SCOPE OF M&S

LEGEND:-

± 0.000 INDICATES GROUND LEVEL

| REV | DATE | DESCRIPTION | SIGN |
|-----|----------|--|------|
| 04 | 22-01-13 | EXISTING CENTRE OXYGEN VESSEL REMOVED | |
| 03 | 22-01-13 | EXISTING CENTRE OXYGEN VESSEL TO BE REMOVED | |
| 02 | 17-09-12 | DRAWING REVISED FOR THE PROPOSED FOUNDATIONS | |
| 01 | 03-02-10 | FOUNDATION SIZE REVISED AS PER REVISED VESSEL SIZE | |

| | | | | | |
|---|-------|--|---------------------|-----------------------|---------------|
| TYPE OF PRODUCT OR NAME OF CUSTOMER/PROJECT | | OXYGEN STORAGE VESSEL (INSIDE FACTORY) | | | |
| Bharat Heavy Electricals Ltd UNIT: HIGH PRESSURE BOILER PLANT TIRUCHIRAPALLI - 620014 | | DRN | J.Dhanabai | SIGNATURE | DATE 22.01.13 |
| | | CHD | T.Aaruyir Yogaa | | 22.01.13 |
| | | APPO | K.Gunasekaran | | 22.01.13 |
| DEPT | civil | SCALE | WEIGHT (Kg) | REF TO ASSY / OLD DWG | ITEM NO |
| CODE | 2200 | C/M/F | | | No OF ITEMS |
| TITLE | | CARD CODE | DRAWING NO : | | REV |
| SITE CUM LAYOUT DRAWING FOR OXYGEN STORAGE VESSEL,VAPOURISER&CRYOPUMP - AS BUILT DRAWING | | U 01 | BHE:CP:01:386/09 04 | | 04 |

CAUTION: The information on this drawing is the property of Bharat Heavy Electricals Ltd. It must not be used directly or indirectly in any way without the prior written consent of the company.