 <p>SOLAR BUSINESS DIVISION</p>	<p>NOTICE INVITING TENDER (NIT) Rev 00</p>	<p>TENDER NO. 278561</p>
---	---	---------------------------------

2026

**BHARAT HEAVY ELECTRICALS LIMITED
SOLAR BUSINESS DIVISION, BENGALURU
TENDER DOCUMENT**

Name: A K Jaiswal

Designation: Manager/WCC

BHEL- SBD, Bengaluru

 SOLAR BUSINESS DIVISION	NOTICE INVITING TENDER (NIT) Rev 00	TENDER NO. 278561
---	--	--------------------------

NOTICE INVITING TENDER

1. BHEL/ SBD (A Govt. of India Enterprise) invites Tender for engaging a Contractor for **Type Testing of BHEL KAVACH Panels & its accessories.**
2. The enquiry has been floated through e-procurement and offers shall be accepted through e-procurement only. BHEL shall neither entertain offers through hard copy nor provide any due date extension on account of the same. Interested vendors who do not have login ID and password are requested to register themselves on <https://eprocurebhel.co.in> through “Online Bidder Enrolment” link available on the portal.
3. Class-III, SHA2 2048 BIT – Signing & Encryption, Digital Signature Certificate (DSC) is required for bidders for authentication purpose (log in and bid submission). Vendors, who do not possess the DSC, are requested to obtain the same. The procedure for obtaining DSCs is detailed in the “Seller Manual” available on the above-mentioned website.

TENDER DOCUMENT VOLUME - I

1.	GENERAL INFORMATION
2.	SCOPE OF WORK
3.	PRE- QUALIFICATION CRITERIA
4.	OTHERS ELIGIBILITY CRITERIA
5.	PRICE VARIATION CLAUSE
6.	PAYMENT TERMS
7.	ANNEXURES

 SOLAR BUSINESS DIVISION	NOTICE INVITING TENDER (NIT) Rev 00	TENDER NO. 278561
---	--	--------------------------

1.	General Information			
1.1.	Tender Reference Number:	278561		
1.2.	Tender Name:	Type Testing of BHEL KAVACH Panels & its accessories		
1.3.	Location of Site	BHEL DOCUMENT NUMBER: EN-TS-04-52-505-K-003- CLAUSE 2 for type testing location		
1.4.	Tender System	Single Stage, Two Part Bid (through E-procurement portal) Part-I-Technical Bid-Tender NIT includes Volume-I, II, Technical specification, GCC. Part-II-Financial Bid- Tender Price bid.		
1.5.	Tender Type	Open Tender - One-time contract		
1.6.	Estimated Value	Rs 35,50,288/- excl GST		
1.7.	Duration of contract	Work order shall be valid for One year from the date of placement of Purchase Order. Delivery Period: BHEL shall provide equipment/ panels and accessories to be tested to the laboratory. Laboratory/Testing agency shall complete testing within 120 days of delivery of equipments to laboratory.		
1.8.	Qualifying Requirement	As per PQC criteria and other NIT terms compliances		
1.9.	Earnest Money Deposit to accompany Tender	Not Applicable		
1.10.	Security Deposit	Not Applicable		
1.11.	Warranty	Not applicable		
1.12.	Cost of Tender documents	NIL		
1.13.	Price Variation Clause (PVC)	Not Applicable		
1.14.	LD/Penalty	Refer BHEL DOCUMENT NUMBER: EN-TS-04-52-505-K-003- CLAUSE 10 for LIQUIDATED DAMAGES		
1.15.	Reverse Auction	<i>“BHEL shall be resorting to Reverse Auction (RA) (Guidelines as available on www.bhel.com) for this tender. RA shall be conducted among the techno-commercially qualified bidders. Price bids of all techno-commercially qualified bidders shall be opened and same shall be considered for RA. In case any bidder(s) do(es) not participate in online Reverse Auction, their sealed price bid along with applicable loading, if any, shall be considered for ranking”.</i>		
1.16.	Dealing Officer (For any Clarifications)	<table border="0"> <tr> <td style="vertical-align: top;"> (i) Commercial Ajeet Kumar Jaiswal, Manager – Works Contract Cell Contact No: 080-22182246 </td> <td style="vertical-align: top;"> (ii) Commercial Mr. Pragadessh T G Sr. Manager – Works Contract Cell Contact No.: 080-2218-2232 Email: pragadeeshtg@bhel.in </td> </tr> </table>	(i) Commercial Ajeet Kumar Jaiswal, Manager – Works Contract Cell Contact No: 080-22182246	(ii) Commercial Mr. Pragadessh T G Sr. Manager – Works Contract Cell Contact No.: 080-2218-2232 Email: pragadeeshtg@bhel.in
(i) Commercial Ajeet Kumar Jaiswal, Manager – Works Contract Cell Contact No: 080-22182246	(ii) Commercial Mr. Pragadessh T G Sr. Manager – Works Contract Cell Contact No.: 080-2218-2232 Email: pragadeeshtg@bhel.in			

 SOLAR BUSINESS DIVISION	NOTICE INVITING TENDER (NIT) Rev 00	TENDER NO. 278561
---	--	--------------------------

		Email: ajaiswal@bhel.in Or (i) Technical: Mrs. Madhushree Pandey MANAGER/ TCAS E-Mail: madhushree@bhel.in Phone: +91- 080-2218-2250
1.17.	Bid participation note	Firms debarred/Banned by BHEL are not eligible to participate in the tender. Any bidder on whom Show Cause Notice / Risk & Cost action initiated/action due to non-performance implemented, are not eligible for participation in this tender. The tender envelope submitted by such a firms/ bidder will not be considered for evaluation and no communication in this regard will be entertained.
1.18.	Site Visit Requirement	Not Applicable
1.19.	Pre-Bid meeting	Not Applicable
1.20.	Splitting	Not Applicable
1.21.	Issue of tender documents	As per Enquiry / RFQ / Notification on www.bhel.com & https://eprocurebhel.co.in
1.22.	Pre- BID Meeting	As per Enquiry / RFQ / Notification on www.bhel.com & https://eprocurebhel.co.in
1.23.	Last date for Issue of tender documents	As per Enquiry / RFQ / Notification on www.bhel.com & https://eprocurebhel.co.in
1.24.	Last date for submission of tender doc	As per Enquiry / RFQ / Notification on www.bhel.com & https://eprocurebhel.co.in
1.25.	Date and time of opening of Tender (Part-A)	As per Enquiry / RFQ / Notification on www.bhel.com & https://eprocurebhel.co.in
1.26.	Tender Submission Place	Online at https://eprocurebhel.co.in
1.27.	Tender Opening Place	Online at https://eprocurebhel.co.in
2.	SCOPE OF WORK	
2.1.	The scope of this specification covers services for Type Testing of Stationary KAVACH, Onboard KAVACH & Remote Interface Unit Panels and its accessories as required for complying with RDSO/SPN/196/2020 Version 4.0 d3 or latest version and RDSO_SPN_144_2006 Rev 2 Dated 14.03.2006. Refer enclosed Specification: EN-TS-04-52-505-K-003 Rev 02 for “TYPE TESTING OF BHEL KAVACH SYSTEM” attached for detail Scope of Service.	
3.	PRE- QUALIFICATION CRITERIA (PQC)	
	BHEL Requirement	Documents to be submitted for evaluation along with the technical offer
3.1.	The bidder shall be an NABL-accredited Testing Laboratory as per ISO/IEC 17025	NABL Accreditation Certificate as per ISO/IEC 17025
3.2.	Pre-Qualification Criteria: (Technical) The bidder shall have experience in testing and successful completion of Type	Purchase order(s) or proof of services or Invoices or Test Reports to be submitted for similar works*

 SOLAR BUSINESS DIVISION	NOTICE INVITING TENDER (NIT) Rev 00	TENDER NO. 278561
---	--	--------------------------

	testing of kavach panels as per applicable IS/IEC standards (as per annexure-1, which is in accordance with RDSO specifications: RDSO/SPN/196/2020 version 4, amendment 3 effective from 07.06.2024 or latest or KAVACH Version 3.2 & acceptance test format for kavach as per RDSO/SPN/196/2020 (version 4.0) effective from 08.11.2024 or latest & specification for safety and reliability requirement of electronic signaling equipment - RDSO/ SPN/ 144/2006 Revision 2 effective from 14.03.2006 or latest)	conducted within last five years from the date of tender. “*Similar works” is defined as service delivery to Railways or RDSO or RDSO Approved KAVACH Vendors or RDSO Approved KAVACH Developmental Vendors
3.3.	Financial PQC: Average Annual Financial turnover during the last 3 years ending 31st March of the previous financial year, should be at least INR 10.65 Lakhs excluding GST.	Audited Balance sheet and profit& Loss account OR Turn over Certificate from Chartered Accountant to be enclosed for the FY 22-23 23-24 and 24-25 along with ITR.
3.4.	The selected lab should be capable of carrying out in-house, at least 50 % tests as specified in annexure-1. If required other tests, for which facility is not available at parent lab, may be offloaded to any other NABL accredited lab / Government lab (offloading limited to one lab only) for which qualification criteria will be NABL Accreditation Certificate as per ISO/IEC 17025. However, all responsibility for offloaded tests and their appropriate test report shall rest with parent lab. Credentials of the outsourced labs to be submitted in bid.	1. Self-certification in case of 100 % inhouse testing. or 2. For offloaded laboratory, NABL Accreditation Certificate as per ISO/IEC 17025.
	Note: BHEL reserves the right to verify the documents submitted by the bidder. During verification, if it is found fake/forged/manipulated, suitable penal action shall be taken against bidder as per extent guidelines of BHEL for suspension of business dealing.	
4.	OTHERS ELIGIBILITY CRITERIA	
4.1.	The bidder shall also mention the PAN Number issued by Income Tax Department, copy of the PAN card or PAN number allotment letter shall be submitted along with the tender documents.	
4.2.	A copy of GST to be submitted.	

 SOLAR BUSINESS DIVISION	NOTICE INVITING TENDER (NIT) Rev 00	TENDER NO. 278561
---	--	--------------------------

4.3.	There should be no litigation or charge under investigation / enquiry / trial against the Tenderer, or conviction in a court of law or suspension or blacklisting by any organization on any ground. During the course of work, if any such information comes to light, the contract may be terminated.
4.4.	The opinion / decision of BHEL regarding the bid shall be final and conclusive. BHEL reserves the right to reject any or all the bids at any time without assigning any reason.
4.5.	In case the bidder has a relative employed in BHEL, the authority inviting tender shall be informed of this fact in writing at the time of submission of tender, failing which the tender may be disqualified, or if such fact comes to light subsequently, the contract may be terminated.
4.6.	If the bidder gives wrong information in his tender or creates conditions favorable for the acceptance of his tender, BHEL reserves the right to reject such tender at any stage.
5.	PRICE VARIATION CLAUSE (PVC): Not Applicable
6.	<u>PAYMENT TERMS</u>
6.1.	Refer BHEL DOCUMENT NUMBER: EN-TS-04-52-505-K-003- Clause 7 of Milestone based payment terms.
6.2.	Payment timeline from the date of certification of invoice/bill: Payment time line shall be 45 days for Micro & Small Enterprises (MSEs), 60 days for Medium Enterprises and 90 days for Non-MSME bidders from date of certification of invoice/bill.
6.3.	All payments will be made through BHEL SUVIDHA Portal.
6.4.	No advance payment is applicable for the contract
6.5.	Micro & Small Enterprises (MSEs) and Medium Enterprises can also avail the benefits of payments through TReDS platforms. Currently BHEL is empaneled with M/s RXIL, Invoicemart - M/s A.TREDS Ltd. & M/s M1xchange for payments through TReDS platforms.
7.	<u>Annexures</u>
7.1	Detailed Scope of Work – Annexure I
7.2	ANNEXURE – II TECHNO-COMMERCIAL BID APPLICATION
7.3	Bidder Information – Annexure III
7.4	CHECKLIST OF ENCLOSURES – Annexure IV
7.5	Declaration by Bidder-I – Annexure V
7.6	Declaration by Bidder-II – Annexure VI
7.7	Unpriced Price BID - Annexure VII
7.8	PPP-MII Format- Annexure VIII
7.9	Deviations Sheet- Annexure IX
7.10	Conflict of Interest among Bidders/ Agents- Annexure X
8.	<u>MSEs bidders to note the following:</u>
8.2	Micro & Small Enterprises (MSEs) bidder can avail the purchase preference only if they submit along with the offer, copy of Valid UDYAM Certificate. Non-submission of such document will lead to consideration of their bid at par with other bidders. No benefit shall be applicable for this enquiry if any deficiency is observed in the above required documents or all required documents are not submitted before price bid opening.

 SOLAR BUSINESS DIVISION	NOTICE INVITING TENDER (NIT) Rev 00	TENDER NO. 278561
---	--	--------------------------

8.3	<p>MSE vendors quoting within a price band of L1 + 15% shall be allowed to supply 100 % of the requirement against this tender provided:</p> <ol style="list-style-type: none"> 1. The MSE vendor matches the L1 price. 2. L1 price is from a non MSE vendor. 3. L1 price will be offered to the vendor nearest to L1 in terms of price ranking (L2 – nearest to L1). In case of non-acceptance by the MSE vendor (L2), next ranking MSE vendor will be offered who is within the L1+ 15% band (if L3 is also within 15% band).
8.4	<p>In this tender considering the nature of service being critical in nature, the exemption of Experience and Turnover criteria for MSEs and Start-ups are Not Applicable.</p>
8.5	<p>In the course of evaluation, if more than one bidder happens to occupy L-1 status, effective L-1 will be decided after RA. Ranking will be decided after RA accordingly. BHEL's decision in such situations shall be final and binding.”</p>
9.0	<p><u>Loading criteria in case deviation on payment time line clause</u></p>
9.1	<p>The bidders are requested to accept the BHEL payment terms specified in clause no 6.2 of this NIT. If any bidders take deviations in the payment term the following loading criteria shall be applicable.</p> <p>Base rate of RBI repo rate (as applicable on the date of Techno-commercial bid opening) + 4%', shall be considered for loading for the period of relaxation sought by bidders.</p>
9.2	<p><u>Loading criteria calculation:</u> In case any qualified bidder takes deviation (i.e., reduction of time period in payment terms from BHEL standard payment terms, the ranking of L-1, L-2, L-3, etc. will be decided on Interest-Based loading criteria as mentioned below:</p> <p>Loading criteria calculation:</p> <ol style="list-style-type: none"> i. Evaluated bid price= Quoted price + Loading amount (Rs.) ii. Loading amount = Quoted price (Rs.) X Reduction period/365 X Interest Rate (%) iii. Reduction period= Standard payment term - offered payment term (in days) iv. Interest rate= RBI Repo Rate as on Techno-commercial bid opening date+4% <p>Commercial loading shall be added by the respective bidder in its price during Reverse Auction. Modalities of loading & de-loading shall be separately intimated to the bidders. The responsibility for correctness of total cost to BHEL shall lie with the bidders.</p>

 <p>SOLAR BUSINESS DIVISION</p>	<p>NOTICE INVITING TENDER (NIT) Rev 00</p>	<p>TENDER NO. 278561</p>
---	---	---------------------------------

7.1 ANNEXURE – I: SCOPE OF WORK

Refer Specification of Type Testing of BHEL KAVACH System for Indian Railways under BHEL DOCUMENT NUMBER: EN-TS-04-52-505-K-003- Rev 02 enclosed with this NIT.

 SOLAR BUSINESS DIVISION	NOTICE INVITING TENDER (NIT) Rev 00	TENDER NO. 278561
---	--	--------------------------

7.2 ANNEXURE – II TECHNO-COMMERCIAL BID APPLICATION

To,

Manager/WCC/ WCC
Bharat Heavy Electricals Limited
Solar Business Division,
IISc Post, Malleswaram,
Bengaluru – 560 012

Dear Sir,

I / We hereby offer to carry out the contract for **“Type Testing of BHEL KAVACH Panels & its accessories”**.

I /We have carefully perused the all the clauses mentioned in NIT (Complete Tender documents and other T&C) and agree to abide with the same.

I/ We further agree to execute all the works referred to in the said documents.

I declare that, there was never / is no litigation or charge under investigation / enquiry / trial against me / us, nor conviction in a court of law or suspended or blacklisted by any organization on any grounds.

Signature of Tenderer

Date:

 SOLAR BUSINESS DIVISION	NOTICE INVITING TENDER (NIT) Rev 00	TENDER NO. 278561
---	--	--------------------------

7.3 ANNEXURE – III: BIDDER INFORMATION

S. No.	DETAILS REQUIRED	Bidder Requirement fulfilled (Yes / No / NA/ Value/Tick)	
1	Name of the Enterprise / Company / Firm		
2	Name of Authorized Signatory		
3	Type Under MSE (tick mark category) OWNERSHIP STATUS (SC/ ST OR WOMEN-OWNED OR OTHERS)	1. MICRO 2. SMALL 3. SC/ST owned 4. Women Owned 5. Others (excluding SC/ST/Women owned	<input type="checkbox"/> <input type="checkbox"/> <input type="checkbox"/> <input type="checkbox"/> <input type="checkbox"/>
4	Name of Contact person for this tender		
5	Email-id of contact person		
6	Contact number		
7	Bank Account Details (Name of Bank, Branch and Account Number). Cancelled Cheque to be enclosed		
8	Details of Relatives employed in BHEL, Name Designation and Unit - Clause 4.8	If no relative: Write NIL	
	Relative 1		
	Relative 2		
	Relative 3		

 SOLAR BUSINESS DIVISION	NOTICE INVITING TENDER (NIT) Rev 00	TENDER NO. 278561
---	--	--------------------------

7.4 ANNEXURE – IV: CHECKLIST OF ENCLOSURES

S. No.	DETAILS REQUIRED	Requirement fulfilled (Yes / No / NA/ Value)	Whether proof / document enclosed (YES / NO)
1	Documentary Evidence as per Clause 3.1, 3.2 & 3.4		
2	Declaration as per cl. 4.3		
3	Copy of GST (under Cl. 4.2)		
4	Average turnover of last 3 years - Clause 3.3		
5	PAN No. - Clause 4.1		
6	Deleted		
7	Deleted		
8	Non-Disclosure Agreement		
9	EMD Details (DD No., Amount, Date & Bank)	NA	NA
10	Annexure I to X		

 SOLAR BUSINESS DIVISION	NOTICE INVITING TENDER (NIT) Rev 00	TENDER NO. 278561
---	--	--------------------------

7.5 ANNEXURE – V: BIDDER DECLARATION - I

S. No.	DETAILS REQUIRED	Requirement fulfilled (Yes / No / NA/ Value)
1	I have carefully read the Tender Terms and Conditions and I submit my agreement for the same.	
2	I have completely understood the scope of work and submit my agreement to carry out the work as per mentioned in Tender document.	
3	I have quoted rates for the total scope of work mentioned in the tender document	
4	I have understood and accepted the payment terms of BHEL as per Cl.6	
5	I am responsible for the safety of workmen deployed and agree to fulfil the requirements as per tender terms	
6	I agree to participate in the tender and carry out the work (if awarded) ethically and submit my agreement to various requirements in this contract.	
7	I have carefully read the Tender Terms and Conditions and I submit my agreement for the same.	
8	Signed and submitted the deviations sheet	

 SOLAR BUSINESS DIVISION	NOTICE INVITING TENDER (NIT) Rev 00	TENDER NO. 278561
---	--	--------------------------

7.6 ANNEXURE – VI, BIDDER DECLARATION - II

I, -----, aged-----Yrs., S/o -----,

Residing at -----

Hereby declare as follows:

- (i) That my nationality is _____.
- (ii) That I am a major and eligible to enter into contract / my firm / my company is competent to enter into an agreement.
- (iii) I shall employ only such personnel who have not been found unfit for employment in Organizations such as Central / state / Public undertaking by the Police Authorities.
- (iv) I shall not employ persons against whom Criminal cases are pending or under investigation.
- (v) I shall also not employ persons found guilty of offences involving moral turpitude for executing work in BHEL contracts.
- (vi) That there are no Criminal cases/Civil/Labor pending or under investigation against me or my firm or company.
- (vii) I have not been found guilty of offences involving moral turpitude nor any of the company directors / partners of my firm have been found guilty of offences involving moral turpitude.
- (viii) Neither I nor my firm nor my company has been declared insolvent in the past.
- (ix) I have taken due care and efforts to furnish only information which are true in the tender document.
- (x) I shall employ labor who is more than 18 years of age and less than 60 years and having sound physical and mental health.
- (xi) I shall keep Photograph / identity proof / residential proof of the laborers to be employed against this tender and arrange for police verification.
- (xii) I shall employ and deploy suitable qualified personnel for supervision of the work in each shift and additionally as required for monitoring compliance to process requirements and compliance to contract terms & conditions.

[Signature with Name & seal of the Tenderer]

Date :
Place

 <p>SOLAR BUSINESS DIVISION</p>	<p>NOTICE INVITING TENDER (NIT) Rev 00</p>	<p>TENDER NO. 278561</p>
---	---	---------------------------------

**7.7 ANNEXURE VII Unpriced BID-
Refer enclosure with this NIT**

7.8 ANNEXURE- VIII, PPP-MII Format

**FORMAT FOR VERIFICATION OF LOCAL CONTENT UNDER PREFERENCE TO
MAKE IN INDIA ORDER**

(To be submitted with the offer)

[Applicable for procurement value from Rs. 5.00 Lac to Rs. 10.00 Crore]

Self-certification giving the percentage of local content, in line with PPP-MII order, if applicable [to be submitted on the letter head of the issuer.]

Item Name: **Type Testing of BHEL KAVACH Panels & its accessories**

Enquiry No.: **278561**

Project: **BHEL KAVACH Panels & its accessories for BHEL SBD**

Applicable percentage of Local Content.....

(Bidder to indicate local content in percentage)

We have read and understood the provisions of “Public Procurement (Preference to Make in India) Order, 2017” dated 15/06/2017, its revision dated 28/05/2018 and any subsequent modifications/Amendments, if any [hereinafter, “PPP-MII Order”] issued by Department of Industrial Policy and Promotion (DIPP), Ministry of Commerce and Industry, Government of India.

In line with the provisions of the PPP-MII Order, We, M/s. [Enter the name of the Bidder] [hereinafter, “Local Supplier”] submits self-certification to M/s. Bharat Heavy Electricals Limited [hereinafter, BHEL] regarding Local Content in Goods/Services/Works to be supplied by the Local Supplier for the “**Type Testing of BHEL KAVACH Panels & its accessories**”, wherein we have agreed to abide by the terms and conditions of the PPP-MII Order.

Details of location at which local value addition will be made is as follows:

We also understand, false declarations will be in breach of the Code of Integrity under Rule 175(1)(i)(h) of the General Financial Rules for which a bidder or its successors can be debarred for up to two years as per Rule 151 (iii) of the General Financial Rules along with such other actions as may be permissible under law.

For and on behalf of, Date:

Authorized Signatory

(With Company Seal & Signature)

Note: This is a guiding format. In case the bidder submits the certificate in a format different from the above, the same may be considered provided it meets the intent and purpose, as may be ascertained by BHEL.

7.7 Unpriced Price BID - Annexure VII

Validate		Print		Help		Percentage BoQ			
Tender Inviting Authority: SDGM									
Name of Work: Type Testing of BHEL KAVACH Panels & its accessories									
Contract No: 278561									
Name of the Bidder/ Bidding Firm / Company :									
PRICE SCHEDULE									
<p>(This BOQ template must not be modified/replaced by the bidder and the same should be uploaded after filling the relevant columns, else the bidder is liable to be rejected for this tender. Bidders are allowed to enter the Bidder Name and Values only)</p> <p>Notes:</p> <p>1. Rates of Below mentioned items referred in BOQ is firm.</p> <p>2. CONTRACTOR SHOULD QUOTE PERCENTAGE (%) ABOVE/BELOW (OR) AT PAR WITH RESPECT TO TOTAL AMOUNT.</p> <p>3. QUOTED PERCENTAGE (%) IS APPLICABLE ON ALL ITEM RATES UNIFORMLY.</p> <p>4. GST Extra applicable (on Total Quoted Price/Rate).</p>									
NUMBER #	TEXT #	NUMBER #	TEXT #	NUMBER	NUMBER #	TEXT #			
Sl. No.	Test Category/Type	Quantity	Units	Estimated Rate in Rs. P	TOTAL AMOUNT Without Taxes in Rs. P	TOTAL AMOUNT In Words			
1	2	4	5	6	53	55			
	Type Testing of BHEL KAVACH Panels & its accessories as per Annexure 1 of BHEL Technical Specification EN-TS-04-52-505-K-003								
1.00	Developmental Tests (As per SI No 3.00- 1,2,3,4,5,6)	1	Set	567500.00	567500.000	INR Five Lakh Sixty Seven Thousand Five Hundred Only			
2.00	Environmental/Climatic Test								
2.01	Dry heat test (Operation) For functional trials: Temp. 70 °C, Duration: 16 hrs. As per IS: 9000 Pt.III Section: V	1	Set	49000.00	49000.000	INR Forty Nine Thousand Only			
2.02	Dry heat test (Storage) Temp. 75 °C, Duration: 16 hrs. As per IS: 9000 Pt.III Section: V	1	Set	49000.00	49000.000	INR Forty Nine Thousand Only			
2.03	Cold Test (Operation) Temp. -10 °C ± 3 °C, Duration: 2 hrs. As per IS: 9000, Pt. II	1	Set	15500.00	15500.000	INR Fifteen Thousand Five Hundred Only			

2.04	Rapid Variation Temperature Test/ Change of Temp Test -10 ±3 °C to +70 °C±2 °C, Duration: 7 hrs at each temperature. Rate of change: 1°C per Minute. No. of cycle: 03 As per IS: 9000 Pt. XIV Section: II	1	Set	134500.00	134500.000	INR One Lakh Thirty Four Thousand Five Hundred Only
2.05	Damp heat test (steady state storage) RH 93% (+2%, -3%) @ 40 °C±2 °C Duration = 4 days, As per IS: 9000 Pt. IV	1	Set	269000.00	269000.000	INR Two Lakh Sixty Nine Thousand Only
2.06	Damp heat test (Cyclic) RH 95% (+1%, -5%) @ 40 °C ±2 °C (high), 25 °C (low)Duration: 12 + 12 = 24 hrs. cyclic No. of cycles = 6 (Fully functional during one hour period toward end of each cycle. Stabilisation shall be done at 25± 3°C). As per IS: 9000 Pt. V Section-II	1	Set	367500.000	367500.000	INR Three Lakh Sixty Seven Thousand Five Hundred Only
2.07	Bump Test (Package) Peak acceleration 400 m/s ² or 40g, 1000 bumps per axis Duration: 6 milliseconds No. of axes: 03, As per IS: 9000 Pt. VII Section II	1	Set	80937.50	80937.500	INR Eighty Thousand Nine Hundred & Thirty Seven and Paise Fifty Only
2.08	Mechanical Shock Peak acceleration: 20g Pulse Duration: 11 millisecc (Half sine pulse). Total No. of shocks: 18 No. of axes: 3 shocks in each direction Equipment in unpacked condition shall be subjected Mechanical Shock. In addition to physical checks, the assembly shall be subjected to performance test. As per IS: 9000 Pt. VII , Section- I or IEC 60068-2- 27 -2008	1	Set	99375.00	99375.000	INR Ninety Nine Thousand Three Hundred & Seventy Five Only

2.09	Mechanical Shock Peak acceleration: 40 g. Duration of the pulse: 11 m.sec. No. of shocks: 18 Velocity change : Half sine pulse, As per IS 9000 Part VII Sec. 1 Clause 9	1	Set	28125.00	28125.000	INR Twenty Eight Thousand One Hundred & Twenty Five Only
2.10	Vibration test Freq. Range: 5 Hz to 350 Hz Acceleration: 2 g No. Of Axis: 3 No. Of Sweep cycles: 20 Total Duration: 105 min/axis If resonance is observed: 10 minutes at each resonant frequency.As per IS: 9001 Pt. XIII	1	Set	105750.00	105750.000	INR One Lakh Five Thousand Seven Hundred & Fifty Only
2.11	Vibration test Freq. Range: 5 Hz to 150 Hz Acceleration: 3 g. No. Of Axis: 3 No. of Sweep cycles: 20	1	Set	160125.00	160125.000	INR One Lakh Sixty Thousand One Hundred & Twenty Five Only
2.12	Salt Mist Test-On Board (inside cab) & Indoor Procedure 3: Salt Duration: 2hrs, Mist Duration =22 hours 35± 3°C, RH: 93% (+2, -3%) No. of cycles: 03 As per IS: 9000 Pt. XI	1	Set	43450.00	43450.000	INR Forty Three Thousand Four Hundred & Fifty Only
2.13	Salt Mist Test- On Board (outside cab) & Outdoor (On Track /Track side) Procedure 2: Salt Duration: 2hrs, Mist: Duration=7 days 35° ± 3°C, RH: 93% (+2, -3%) No. of cycles: 04 As per IS: 9000 Pt. XI	1	Set	401400.00	401400.000	INR Four Lakh One Thousand Four Hundred Only
2.14	Dust test 1 hour only As per IS: 9000 Pt.XII	1	Set	59375.00	59375.000	INR Fifty Nine Thousand Three Hundred & Seventy Five Only
2.15	Water Immersion Test Head of water 1 m Duration 24 hours Condition After this test, electrical parameters shall be monitored in addition to physical checks (Ingress of water). As per Annexure F & RDSO/SPN/1 44/2006 Rev 02 : Clause 9.3 - 8/ IS 9000 Part XV Sect. 7	1	Set	61250.00	61250.000	INR Sixty One Thousand Two Hundred & Fifty Only

2.16	Driving Rain test Water spray for 1 hour As per IS 9000 Part XVI Test condition 'c'	1	Set	79000.00	79000.000	INR Seventy Nine Thousand Only
2.17	Insulation Resistance (IR) Test after completion of each Climatic Clause This test shall be conducted between the equipment power supply line terminals and the earth. Clause no. 23.4.1 (b) of RDSO/SPN/196/2020 SRS Ver.-4.0, Ref.- 9.5 (c) of RDSO/SPN/144/2014	1	Set	141000.00	141000.000	INR One Lakh Forty One Thousand Only
3.00	EMI/EMC					
3.01	Variation and interruption of voltage supply 1. Voltage fluctuations lying between 0.6 Un and 1.4 Un and not exceeding 0.1s (100msec) shall not cause deviation of function. Note : Un is Nominal voltage Onboard KAVACH: 72 VDC Nominal voltage 0.6 Un = 43.2V, 1.4 Un = 100.8 VDC (Input voltage variation from 43.2 VDC to 100.8 VDC) Onboard KAVACH: 110VDC Nominal voltage 0.6 Un = 66.0V, 1.4 Un = 154.0 VDC (Input voltage variation from 66.0 VDC to 154.0 VDC) 2. Interruption of voltage supply: system input power supply ON/OFF Interruptions up to 10ms. This shall not cause any equipment failure. As per (Class: S2) to equipment tests as per clause 5.1.1.2 and 5.1.1.3 of IEC 60571 -2012 in accordance with IEC-61000-4.29 or relevant clause of latest amendment/issue.	1	Set	102500.00	102500.000	INR One Lakh Two Thousand Five Hundred Only
3.02	Supply Overvoltage 1. Supply over-voltage (as per below Table) i. Voltage level (minimum) 1.4 Un Note : Un is Nominal voltage Onboard KAVACH: 72V Nominal Voltage: 100.8V DC 110V Nominal voltage : 154.0V DC ii. Duration d(max) raise time, fall time : 0.1Sec iii. Duration D (maximum) stable state : 1.0 Sec As per clauses 5.2 & 12.2.7 of IEC 60571 -2012 in accordance with IEC-61000-4.29 or relevant clause of the latest amendment/issue. Electrostatic discharge tests shall be carried out as per Clause 9.4.1 of RDSO/SPN/144/2006 or the relevant clause of the latest amendment.	1	Set	135000.000	135000.000	INR One Lakh Thirty Five Thousand Only
3.03	Surge Tests Surges (as per below Table) Apply between the system voltage potential return and equipment earth terminal. Voltage level (Tolerance +/-3 %) : 1800 V Raise time (10% to 90% voltage level): 5 µs and Raise time 50% to 100%, fall time 100% to 50% : 50 µs. As per clauses 5.2 & 12.2.7 of IEC 60571 -2012 in accordance with IEC-61000-4.29 or relevant clause of the latest amendment/issue. Electrostatic discharge tests shall be carried out as per Clause 9.4.1 of RDSO/SPN/144/2006 or the relevant clause of the latest amendment.	1	Set	121750.00	121750.000	INR One Lakh Twenty One Thousand Seven Hundred & Fifty Only
3.04	7 KV discharge test 1. Chassis of the equipment shall be firmly grounded. 2. A charged capacitor of 7 KV should be discharged by touching the chassis by testing probe through 330Ω resistance and 150pF capacitor. 3. The above discharge test should be repeated minimum 3 times. As per RDSO/SPN/144/2006: Clause 9.4.1.	1	Set	105000.00	105000.000	INR One Lakh Five Thousand Only

3.05	Transient Burst & Susceptibility Test Including Electrical Fast transient and Radiated susceptibility, Conducted Susceptibility. As per clause 5.5 of IEC 60571-2012 in accordance with IEC-62236-3-2 or relevant clause of latest amendment/issue	1	Set	106000.00	106000.000	INR One Lakh Six Thousand Only
3.06	Radio Interference Test Including conducted Emission, Radiated emission As per clause 5.5 & 12.2.8 of IEC 60571-2012 in accordance with IEC-62236-3-2 or relevant clause of latest amendment/issue.	1	Set	268250.00	268250.000	INR Two Lakh Sixty Eight Thousand Two Hundred & Fifty Only
Total in Figures					3550287.500	INR Thirty Five Lakh Fifty Thousand Two Hundred & Eighty Seven and Paise Fifty Only
Quoted Rate in Figures			Select		0.000	INR Zero Only
Quoted Rate in Words		INR Zero Only				

 <p>SOLAR BUSINESS DIVISION</p>	<p>NOTICE INVITING TENDER (NIT) Rev 00</p>	<p>TENDER NO. 278561</p>
---	---	---------------------------------

7.9 ANNEXURE -IX: DEVIATION SHEET

SI No.	Volume	Part/Clause SI no.	NIT requirement	Bidder's Deviation

Total No. of deviations proposed by the Bidder- _____ nos.

BIDDER'S SIGN & SEAL:

Note: The Offers should be in full conformity with the terms and conditions of this tender. Incorrect and incomplete tenders are liable to be rejected. Deviations, if any, should only be mentioned as per format for Non-Technical Deviations (i.e. General Terms & Conditions, Commercial Terms etc.) & Technical Deviations (i.e. Scope of Work, Modalities of Contract etc.). BHEL at its discretion whether to give any further chance to a bidder in case of any deviation or reject the same offer.

 <p>SOLAR BUSINESS DIVISION</p>	<p>NOTICE INVITING TENDER (NIT) Rev 00</p>	<p>TENDER NO. 278561</p>
---	---	---------------------------------

7.10 ANNEXURE -X

CONFLICT OF INTEREST AMONG BIDDERS/ AGENTS

“A bidder shall not have conflict of interest with other bidders. Such conflict of interest can lead to anti-competitive practices to the detriment of Procuring Entity's interests.

The bidder found to have a conflict of interest shall be disqualified.

The bidder notes that a conflict of interest would said to have occurred in the tender process and execution of the resultant contract, in case of any of the following situations:

- (i) If its personnel have a close personal, financial, or business relationship with any personnel of BHEL who are directly or indirectly related to the procurement or execution process of the contract, which can affect the decision of BHEL directly or indirectly;
- (i) The bidder (or his allied firm) provided services for the need assessment/ procurement planning of the Tender process in which it is participating;
- (ii) Procurement of goods directly from the manufacturers/ suppliers shall be preferred. However, if the OEM/ Principal insists on engaging the services of an agent, such agent shall not be allowed to represent more than one manufacturer/ supplier in the same tender. Moreover, either the agent could bid on behalf of the manufacturer/ supplier or the manufacturer/ supplier could bid directly but not both. In case bids are received from both the manufacturer/ supplier and the agent, bid received from the agent shall be ignored. However, this shall not debar more than one Authorized distributor (with/ or without the OEM) from quoting equipment manufactured by an Original Equipment Manufacturer (OEM) in procurements under a Proprietary Article Certificate.
- (iii) A bidder participates in more than one bid in this tender process. Participation in any capacity by a Bidder (including the participation of a Bidder as a partner/ JV member or sub-contractor in another bid or vice-versa) in more than one bid shall result in the disqualification of all bids in which he is a party. However, this does not limit the participation of an entity as a sub-contractor in more than one bid if he is not bidding independently in his own name or as a member of a JV.

The Bidder declares that they have read and understood the above aspects, and the bidder confirms that such conflict of interest does not exist and undertakes that they will not enter into any illegal or undisclosed agreement or understanding, whether formal or informal with other Bidder(s), in this regard. This applies in particular to prices, specifications, certifications, subsidiary contracts, submission or non-submission of bids or any other actions to restrict competitiveness or to introduce cartelization in the bidding process. In case, the Bidder is found having indulged in above activities, the same will be considered as a violation of the tender conditions, and suitable action shall be taken by BHEL as per extant policies/ guidelines.

Signature with company seal -

Name –

Company / Organization –

Designation within Company / Organization –

Address of Company / Organization –

 SOLAR BUSINESS DIVISION	NOTICE INVITING TENDER (NIT) Rev 00	TENDER NO. 278561
---	--	--------------------------

TENDER DOCUMENT

PART – A

VOLUME - II

1.	INSTRUCTION TO BIDDER
2.	EARNEST MONEY DEPOSIT (EMD):
3.	SECURITY DEPOSIT (SD) :
4.	NON DISCLOSURE AGREEMENT
5.	CONFIDENTIALITY
6.	STATUTORY REQUIREMENTS
7.	PERIOD OF CONTRACT
8.	FAILURE TO COMPLY WITH CONTRACT
9.	SUB-CONTRACTING
10.	LAWS GOVERNING THE CONTRACT
11.	LEGAL JURISDICTION:
12.	SETTLEMENT OF DISPUTES
13.	ARBITRATION
14.	COMPENSATION:
15.	PENALTY/ LD FOR DELAYED DELIVERY
16.	REVERSE AUCTION
17.	CONCILIATION CLAUSE – Annexure IA
18.	MAKE IN INDIA CLAUSE
19.	GOODS & SERVICE TAX (GST) REGISTRATION & COMPLIANCE
20.	FORCE MAJEURE
21.	NO INTEREST PAYABLE TO CONTRACTOR
22.	INTIMATION OF CHANGE OF NAME/ RE-CONSTITUTION OF THE ORGANIZATION
23.	INSURANCE
24.	LIMITATION ON LIABILITY
25.	THIRD PARTY NON-DISCLOSURE AGREEMENT (NDA) FORMAT
26.	EFT FORMAT
27.	GCC
28.	Bank Guarantee Format

 SOLAR BUSINESS DIVISION	NOTICE INVITING TENDER (NIT) Rev 00	TENDER NO. 278561
---	--	--------------------------

1.	INSTRUCTION TO BIDDER
1.1.	<p>Tender is a two-part bid system. The tender documents consist of Part - A and Part - B as detailed below:</p> <ol style="list-style-type: none"> a. Part 'A': Techno-commercial Bid duly sealed and signed to be uploaded at the web-portal (https://eprocurebhel.co.in) on or before the due date. b. Part 'B': Price Bid to be quoted in prescribed format available on web portal (https://eprocurebhel.co.in) on or before the due date.
1.2.	<p>Envelope 1: Techno-Commercial Offer</p> <ol style="list-style-type: none"> a. Documents to be uploaded at NIC web portal (https://eprocurebhel.co.in): <ol style="list-style-type: none"> i. Earnest Money Deposit (EMD) either in the form of DD or UTR Number (if paid through EFT) at the space provided. ii. Duly completed tender documents volume I&II(Part-A) sign and Sealed. iii. Each and every page of tender documents should be sealed signed. iv. Documents satisfying PQR/Eligibility Criteria as per relevant clause of NIT. v. Any other documents as per Tender requirements. vi. Each and every page of tender documents should be sealed & signed by the tenderer vii. Any other documents as per Tender requirements. b. The tenderer shall not indicate the price or rate in this Envelope. <p>Envelope 2: Part 'B': Online Price-Bid.</p> <ol style="list-style-type: none"> i. To be submitted online at NIC web portal (https://eprocurebhel.co.in)
1.3.	The tenderer shall expressly accept all the terms and conditions of the Tender. The tender which does not comply with the BHEL's Terms & Conditions may be rejected as Non-responsive/non-conforming and non-acceptable.
1.4.	The techno-commercial offer will be opened on the due date. The tenders meeting our techno-commercial requirements will be considered for online initial sealed bid auction at a later date for which eligible vendors will be intimated in due course.
1.5.	The tender forms duly filled in all respects shall be signed on each page by the tenderer. Any alteration, erasing will render the tender invalid. Corrections, over writing, cutting(s) etc. are not permitted. All entries in the tender document should be in one ink. All the columns in the tender form should be filled without leaving any column blank in any page of the tender. In case any of the relevant columns are left blank, the tender can be rejected. However, alteration neatly carried out and duly attested over with the full signature of the tenderer is permitted.
1.6.	The tenderer should submit the tender documents intact without detaching any page or pages
1.7.	Before making the offer, the bidders are advised to carefully go through the terms and conditions, which form part of the Agreement.
1.8.	Tender documents consisting of Part 'A' Volume I & II duly sealed and signed and Part 'B' shall be uploaded duly on or before the said Date and Time.

 SOLAR BUSINESS DIVISION	NOTICE INVITING TENDER (NIT) Rev 00	TENDER NO. 278561
---	--	--------------------------

	Part 'A' Volume I & II of tender form i.e. PQR and Techno-commercial Bid will be opened on specified Tender Due Date and Time. Bidders who qualify the PQR & Techno-commercial Bid will be intimated to participate in R.A.
1.9.	BHEL reserves the right to assess the capacity and capability of the parties for pre-qualification. The company also reserves the right to accept or reject any or all the tenders or any part thereof at any stage of process without assigning any reason whatsoever. The company has no obligation to accept the lowest tender. Offer of the Tenderer if prima-facie found not comparable with the quantum of work envisaged and the bid is a desperate effort to be L1, then the offer is liable to be rejected. BHEL's decision in this regard shall be final and binding.
1.10.	PRICE BID - The tenderers are required to submit their quotation for all the items listed in the Price Bid format given along with the tender documents. The price should be quoted for each activity after careful study of the actual job requirement so that, in case the contract is awarded, contractor should not express any difficulties in execution of the contract.
1.11.	Contractor to ensure payment of Minimum Wages payable as per statutory provisions of the Appropriate Govt.
1.12.	VALIDITY OF RATES: The rates quoted should be valid for 90 days initially from the date of opening of the Techno-Commercial bid. (Part-A)
1.13.	The rates shall include the payments on account of Employee contribution to PF, PF Admin. Charges, EDLI, Employer contribution to ESI, Gratuity, Bonus as per statutory requirement, applicable taxes, as per the directives issued by BHEL from time to time.
1.14.	BHEL reserves the right to reject any bid, which is technically unacceptable and unworkable. Further BHEL also reserves the right to reject any or all tenders without assigning any reasons thereof.
1.15.	BHEL reserves the right to cancel the contract at the initial stage or during the contract period without assigning any reason to the tenderer.
1.16.	Wherever prescribed formats are specified for the tenderers use, he shall use the same for making his Claims.
1.17.	Tender document should be complete in all respects.
1.18.	Successful tenderers shall enter into an Agreement on a non-judicial stamp paper of Rs.100/- as a token of having accepted the rates, terms and conditions of the contract as per the Proforma given by BHEL.
1.19.	The Offers should be in full conformity with the terms and conditions of this tender. No contradictions are acceptable. Incorrect and incomplete tenders are liable for rejection.
1.20.	Tenders not submitted in the prescribed forms are liable for rejection.
1.21.	BHEL reserves the right to accept or reject any tender in part or full at their discretion without assigning any reason.
1.22.	If a tenderer deliberately gives wrong information in his tender or creates conditions favorable for the acceptance of his tender, then BHEL reserves the right to reject such tender at any stage.
1.23.	If the tenderer indulges in any unethical practice for securing the contract, the offer of such tenderer shall be rejected.

 SOLAR BUSINESS DIVISION	NOTICE INVITING TENDER (NIT) Rev 00	TENDER NO. 278561
---	--	--------------------------

1.24.	Any written communication required to be sent to the contractor in writing shall be sent at the address mentioned on the tender form or to any other address subsequently intimated by contractor in writing to BHEL SBD for the contract purposes.
1.25.	Evaluation of Bids
1.26.	Techno-Commercial Bid & PQR: The techno-commercial bid & PQR will be evaluated based on the eligibility criteria and on acceptance of NIT terms and conditions of BHEL. Only qualified bids will be eligible for price-bid opening.
1.27.	Evaluation of Price-Bids: Evaluation of the L-1 offer shall be computed on overall lowest cost to BHEL basis (Grand Total Price for all the items indicated in Price Bid minus tax credit, if, any)
1.28.	Compensation to Contractor: No compensation to contractor shall be given for prior completion/ early closure or any negative/ positive variation in contract value.
1.29.	In the course of evaluation, if more than one bidder happens to occupy the L-1 status, effective L- will be decided by soliciting discounts from the respective L-1 bidders. In case more than one bidder happens to occupy L-1 status even after soliciting discounts, the L-1 bidder will be decided by a toss/draw of lots, in the presence of respective L-1 bidder (s) or their representative (s). Ranking will be done accordingly. BHEL's decisions in such situations shall be final and binding
2.	EARNEST MONEY DEPOSIT (EMD): Note Applicable
3.	SECURITY DEPOSIT (SD) : Not applicable
1.	NON DISCLOSURE AGREEMENT. The contractor shall sign a Non-Disclosure Agreement (NDA) as per BHEL format (Copy enclosed) in compliance to Information Security Management System.
2.	CONFIDENTIALITY: The contractor and his representatives shall, at all times, undertake to maintain and ensure complete confidentiality and integrity of all data, information, software, drawings & documents, etc. belonging to BHEL and also of the systems, procedures, reports, input documents, results and any other company documents discussed and/or finalized during the course of execution of the order/contract.
3.	STATUTORY REQUIREMENTS: Refer applicable GCC clause
4.	PERIOD OF CONTRACT
4.1.	Duration of contract is as mentioned in the General Information of NIT
5.	<u>FAILURE TO COMPLY WITH CONTRACT</u>
5.1.	Notwithstanding anything contained in any other clause, BHEL reserves the right to terminate the contract due to any failure on the part of the Tenderer in discharging his obligations under the contract or in the event of his becoming insolvent or going into liquidation. The decision of the BHEL about the failure on the part of the Tenderer shall be final and binding on the tenderer.

 SOLAR BUSINESS DIVISION	NOTICE INVITING TENDER (NIT) Rev 00	TENDER NO. 278561
---	--	--------------------------

5.2.	<p>In case of any damage to the existing building, structures, materials, tools, furniture and fixtures, machines etc., caused from contractor's end, the cost of its repairs or replacement will be recovered from the contractor. If there is any work stoppage in any area of the Plant due to the fault of the tenderer, the tenderer is liable to compensate the same.</p>
5.3.	<p>A) Breach of contract and Termination: In case of breach of contract, 10% of the contract value shall be recovered from the contractor. This 10% of the recovery amount is other than the penalty/LD amount mentioned elsewhere in the contract. In case of breach of contract, wherever the value of security instruments like performance bank guarantee available with BHEL against the said contract is at least 10% of the contract value, the same be encashed. In case the value of the security instruments available is less than 10% of the contract value, the balance amount be recovered from other financial remedies (i.e. available bills of the contractor, retention amount, etc. with BHEL) or legal remedies be pursued. The balance scope shall be got done independently without Risk & Cost of the failed supplier/ contractor.</p> <p>B) Following cases shall be considered as terms of breach of contract:</p> <ol style="list-style-type: none"> i. Contractor/ supplier's poor progress of the work vis-à-vis execution timeline as stipulated in the Contract, backlog attributable to contractor/ supplier including unexecuted portion of work/ supply does not appear to be executable within balance available period considering its performance of execution ii. Withdrawal from or abandonment of the work by contractor before completion of the work as per contract. iii. Non-completion of work/ Non-supply by the Contractor/ supplier within scheduled completion/delivery period as per Contract or as extended from time to time, for the reasons attributable to the contractor/ supplier. iv. Termination of Contract on account of any other reason (s) attributable to Contractor/ Supplier. If at any time the Contractor defaults in proceeding with the work with due diligence and continues to do so or commit any default in complying any of the tender terms and conditions even after the notice in writing is given, BHEL may, without prejudice to any other right to remedy which shall have accrued or shall accrue thereafter to BHEL, to terminate the contract by giving 30 days' notice in writing. The notice will be deemed to have been served as and when sent to the address given in the tender. v. Assignment, transfer, subletting of Contract without BHEL's written permission resulting in termination of Contract or part thereof by BHEL. vi. Non-compliance to any contractual condition or any other default attributable to Contractor/ Supplier. <p>C) The following sequence shall be applicable for recoveries from contractor/ supplier, who has breached the contract:</p> <ol style="list-style-type: none"> i. Dues available in the form of Bills payable to contractor/ supplier, Security deposits, Bank Guarantees against the same contract in BHEL SBD.

 SOLAR BUSINESS DIVISION	NOTICE INVITING TENDER (NIT) Rev 00	TENDER NO. 278561
---	--	--------------------------

	<p>ii. Dues payable to contractor/ supplier against other contracts in BHEL SBD or any other units/regions of BHEL shall be considered for recovery from the Unpaid Bills/Running Bills/SD/BGs/Final Bills of contractor/ supplier.</p> <p>iii. In-case recoveries are not possible with any of the above available options, Legal action shall be initiated for recovery against contractor/supplier.</p>
6.	<u>SUB-CONTRACTING</u>
6.1.	The contractor shall not sub-contract or transfer or assign the contract in full or any part thereof to any other person or firm or company without the previous express written approval of BHEL.
7.	<u>LAWS GOVERNING THE CONTRACT</u>
7.1.	The contract will be governed by the Laws of India for the time being in force and as amended or made from time to time.
7.2.	All disputes shall be settled in accordance with the Laws of India for the time being in force and as amended from time to time.
7.3.	All disputes arising out of or in relation to this contract or Agreement shall be settled by mutual discussions and in the event of failure such disputes shall be referred to the Arbitrator.
8.	<u>LEGAL JURISDICTION:</u>
8.1.	In respect of all matters arising out of or pertaining to the contract, the cause of action thereof shall be deemed to have arisen only at Bengaluru, where BHEL – SBD is situated. All legal proceedings pertaining to the above matters or dispute shall be instituted only in courts having territorial jurisdiction over the place where BHEL-SBD is situated and no other court shall have the jurisdiction.
8.2.	<u>CARTEL FORMATION:</u> The Bidder declares that they will not enter into any illegal or undisclosed agreement or understanding, whether formal or informal with other Bidder(s). This applies in particular to prices, specifications, certifications, subsidiary contracts, submission or non-submission of bids or any other actions to restrict competitiveness or to introduce cartelization in the bidding process. In case, the Bidder is found having indulged in above activities, suitable action shall be taken by BHEL as per extant policies/ guidelines.
9.	<u>SETTLEMENT OF DISPUTES</u> If any dispute or difference of any kind whatsoever shall arise between BHEL and the Supplier/Vendor, arising out of the contract for the performance of the work whether during the progress of contract termination, abandonment or breach of the contract, it shall in the first place referred to Designated Engineer for amicable resolution by the parties. Designated Engineer (to be nominated by BHEL for settlement of disputes arising out of the contract) who within 60 days after being requested shall give written notice of his decision to the contractor. Save as hereinafter provided, such decision in respect of every matter so referred shall forthwith be given effect to by the Supplier/Vendor who shall proceed with the work with all due diligence, whether he or BHEL desires to resolve the dispute as hereinafter provided or not. If after the Designated Engineer has given written notice of this decision to the party and no intention to pursue the dispute has been communicated to him by the affected party within 30

 SOLAR BUSINESS DIVISION	NOTICE INVITING TENDER (NIT) Rev 00	TENDER NO. 278561
---	--	--------------------------

	days from the receipt of such notice, the said decision shall become final and binding on the parties. In the event the Supplier/Vendor being dissatisfied with any such decision or if amicable settlement cannot be reached then all such disputed issues shall be resolved through conciliation in terms of the BHEL Conciliation Scheme 2018 as per Clause 17.
10.	ARBITRATION
10.1.	Except as provided elsewhere in this contract, in case Parties are unable to reach an amicable settlement (whether by Conciliation to be conducted as provided in Clause 17 herein above or otherwise) in respect of any dispute or difference; arising out of the formation, breach, termination, validity or execution of the Contract; or, the respective rights and liabilities of the Parties; or, in relation to interpretation of any provision of the Contract; or, in any manner touching upon the Contract (hereinafter referred to as the ‘Dispute’), then, either Party may, refer the disputes to Arbitral Institution “ Arbitration & Conciliation Centre, Bengaluru (Domestic and International) ” and such dispute to be adjudicated by Sole Arbitrator appointed in accordance with the Rules of the said Arbitral Institution.
10.2.	A Party willing to commence arbitration proceeding shall invoke Arbitration Clause by giving notice to the other party in terms of section 21 of The Arbitration and Conciliation Act, 1996 (hereinafter referred to as the ‘Notice’) before referring the matter to arbitral institution. The Notice shall be addressed to the Head of the Region, Power Sector/ Unit, BHEL, executing the Contract and shall contain the particulars of all claims to be referred to arbitration with sufficient detail and shall also indicate the monetary amount of such claim including interest, if any.
10.3.	After expiry of 30 days from the date of receipt of aforesaid notice, the party invoking the Arbitration shall submit that dispute to the Arbitration & Conciliation Centre, Bengaluru (Domestic and International) and that dispute shall be adjudicated in accordance with their respective Arbitration Rules. The matter shall be adjudicated by a Sole Arbitrator who shall necessarily be a Retd. Judge having considerable experience in commercial matters to be appointed/nominated by the respective institution. The cost/expenses pertaining to the said Arbitration shall also be governed in accordance with the Rules of the respective Arbitral Institution. The decision of the party invoking the Arbitration for reference of dispute to Arbitration & Conciliation Centre, Bengaluru (Domestic and International) for adjudication of that dispute shall be final and binding on both the parties and shall not be subject to any change thereafter. The institution once selected at the time of invocation of dispute shall remain unchanged.
10.4.	The fee and expenses shall be borne by the parties as per the Arbitral Institutional rules.
10.5.	The Arbitration proceedings shall be in English language and the seat and venue of Arbitration shall be in Bengaluru, Karnataka only.
10.6.	Subject to the above, the provisions of The Arbitration & Conciliation Act, 1996 and any amendment thereof shall be applicable. All matters relating to this Contract and arising out of

 SOLAR BUSINESS DIVISION	NOTICE INVITING TENDER (NIT) Rev 00	TENDER NO. 278561
---	--	--------------------------

	invocation of Arbitration clause are subject to the exclusive jurisdiction of the Court(s) situated at Bengaluru, Karnataka only.
10.7.	Notwithstanding any reference to the Designated Engineer or Conciliation or Arbitration herein, the parties shall continue to perform their respective obligations under the Contract unless they otherwise agree. Settlement of Dispute clause cannot be invoked by the Contractor, if the Contract has been mutually closed or 'No Demand Certificate' has been furnished by the Contractor or any Settlement Agreement has been signed between the Employer and the Contractor.
10.8.	It is agreed that Mechanism of resolution of disputes through arbitration shall be available only in the cases where the value of the dispute is less than Rs. 10 Crores.
10.9.	In case the disputed amount Claim, Counter claim including interest is Rs. 10 crores and above, the parties shall be within their rights to take recourse to remedies other than Arbitration, as may be available to them under the applicable laws after prior intimation to the other party. Subject to the aforesaid conditions, provisions of the Arbitration and Conciliation Act, 1996 and any statutory modifications or re-enactment thereof as amended from time to time, shall apply to the arbitration proceedings under this clause.
10.10.	In case, multiple arbitrations are invoked (whether sub-judice or arbitral award passed) by any party to under this contract, then the cumulative value of claims (including interest claimed or awarded) in all such arbitrations shall be taken in to account while arriving at the total claim in dispute for the subject contract for the purpose of clause 13.9. Disputes having cumulative value of less than 10 crores shall be resolved through arbitration and any additional dispute shall be adjudicated by the court of competent jurisdiction.
10.11.	In case of Contract with Public Sector Enterprise (PSE) or a Government Department, the following shall be applicable: In the event of any dispute or difference relating to the interpretation and application of the provisions of commercial contract(s) between Central Public Sector Enterprises (CPSEs)/ Port Trusts inter se and also between CPSEs and Government Departments/Organizations (excluding disputes concerning Railways, Income Tax, Customs & Excise Departments), such dispute or difference shall be taken up by either party for resolution through AMRCD (Administrative Mechanism for Resolution of CPSEs Disputes) as mentioned in DPE OM No. 05/0003/2019-FTS-10937 dated 14-12-2022 as amended from time to time.
11.	COMPENSATION:
11.1.	“BHEL shall recover the amount of compensation paid to victim(s) by BHEL towards loss of life / permanent disability due to an accident which is attributable to the negligence of contractor, agency or firm or any of its employees as detailed below. a) Victim: Any person who suffers permanent disablement or dies in an accident as defined below. b) Accident: Any death or permanent disability resulting solely and directly from any unintended and unforeseen injurious occurrence caused during the manufacturing/ operation and works incidental thereto at BHEL factories/ offices and precincts thereof, project execution, erection and commissioning, services, repairs and maintenance, trouble shooting, serving, overhaul, renovation and retrofitting, trial operation, performance guarantee testing

 SOLAR BUSINESS DIVISION	NOTICE INVITING TENDER (NIT) Rev 00	TENDER NO. 278561
---	--	--------------------------

	<p>undertaken by the company or during any works / during working at BHEL Units/ Offices/ townships and premises/ Project Sites.</p> <p>c) Compensation in respect of each of the victims:</p> <p>(i) In the event of death or permanent disability resulting from Loss of both limbs: ₹10,00,000/- (Rupees Ten Lakhs)</p> <p>(ii) In the event of other permanent disability: ₹7,00,000/- (Rupees Seven Lakhs)</p> <p>d) Permanent Disablement: A disablement that is classified as a permanent total disablement under the provision to Section 2 (I) of the Employee’s Compensation Act, 1923.”</p>
15	<p>PENALTY/ LIQUIDATED DAMAGES (LD): Refer NIT Vol I Clause 1.14 of General Information for LD/Penalty terms</p>
16	<p>REVERSE AUCTION- Terms and conditions (Refer forms) “BHEL shall be resorting to Reverse Auction (RA)-2024-Doc. No. AA:SSP:RA:00 dated 05.12.2024(Guidelines as available on www.bhel.com) for this tender. RA shall be conducted by BHEL assigned agency. Refer Clause 10 for Reverse Auction Process in RA 2024 guidelines.</p>
17	<p>CONCILIATION CLAUSE – Annexure IA Any dispute, difference or controversy of whatever nature howsoever arising under or out of or in relation to this Agreement (including its interpretation) between the Parties, and so notified in writing by either Party to the other Party (the “Dispute”) shall, in the first instance, be attempted to be resolved amicably in accordance with the conciliation procedure as per BHEL Conciliation Scheme 2018. The proceedings of Conciliation shall broadly be governed by Part-III of the Arbitration and Conciliation Act 1996 or any statutory modification thereof and as provided in - “Procedure for conduct of conciliation proceedings” (as available in https://www.bhel.com/bhel-conciliation-scheme-2018-0). Note: Ministry of Finance has issued OM reference No. 1/2/24 dated 03.06.2024 regarding “Guidelines for Arbitration and Mediation in Contracts of Domestic Public Procurement. In the said OM it has been recommended that Government departments/ Entities/agencies are to encourage mediation under the Mediation Act. 2023. Entities/agencies are to encourage mediation under the Mediation Act. 2023. The said Act has not yet been notified by the Government. Therefore, the clause “Settlement of Disputes” shall be modified accordingly as and when the Mediation Act 2023 gets notified.</p>
18	<p>MAKE IN INDIA CLAUSE</p> <p>I. For this procurement, Public Procurement (Preference to MAKE IN INDIA) Order 2017 Dated 15.06.2017, 28.05.2018, 29.05.2019, 04.06.2020 and subsequent orders issued by the respective Nodal Ministry shall be applicable. Even if issued after issue of this NIT but before finalization of contract WO against this NIT.</p> <p>II. In the event of any Nodal Ministry prescribing higher or lower percentage of purchase preference and/ or local content in respect of this procurement same shall be applicable.</p>
19	<p>GOODS & SERVICE TAX (GST) REGISTRATION & COMPLIANCE</p>
	<p>A. Response to tenders for indigenous supplier will be entertained only if the vendor has a valid GST registration number (GSTIN) which should be clearly mentioned in the offer. If the dealer</p>

 <p>SOLAR BUSINESS DIVISION</p>	<p align="center">NOTICE INVITING TENDER (NIT) Rev 00</p>	<p align="center">TENDER NO. 278561</p>
---	--	--

is exempted from GST registration, a declaration with due supporting documents need to be furnished for considering the offer. Dealers under composition scheme should declare that he is a composition dealer supported by the screen shot taken from GST portal. The dealer has to submit necessary documents if there is any change in status under GST.

B. Supplier shall mention their GSTIN in all their invoices (incl. Credit notes, debit notes) and invoices shall be in the format as specified/prescribed under GST laws. Invoices shall necessarily contain invoice number (in case of multiple numbering system is being followed for billing like sap invoice no, commercial invoice no etc., then the invoice no. Which is linked/uploaded in GSTN network shall be clearly indicated), billed to party (with GSTIN) & shipped to party details, item description as per po, quantity, rate, value, applicable taxes with nomenclature (like IGST, SGST, CGST & UTGST) separately, HSN/ SAC code, place of supply etc.

C. All invoices shall bear the HSN code for each item separately (harmonized system of nomenclature)/ sac code (services accounting code).

D. Invoices will be processed only upon completion of statutory requirement and further subject to following: a. Vendor declaring such invoice in form GST anx-1 b. Receipt of goods or services and tax invoice by BHEL

E. As the continuous uploading of tax invoices in GSTN portal (in GST anx-1) is available for all (i.e. Both small & large) tax payers under proposed new GST return system, all invoices raised on BHEL may be uploaded immediately in GST portal on dispatch of material /rendering of services. The supplier shall ensure availability of invoice in GST portal before submission of invoice to BHEL. Invoices will be admitted by BHEL only if the invoices are available in GSTN portal (in BHEL'S GST anx-2).

F. In case of discrepancy in the data uploaded by the supplier in the GSTN portal or in case of any shortages or rejection in the supply, then BHEL will not be able to avail the tax credit and will notify the supplier of the same. Supplier has to rectify the data discrepancy in the GSTN portal or issue credit note or debit note (details also to be uploaded in GSTN portal) for the shortages or rejections in the supplies or additional claims, within the calendar month informed by BHEL.

G. In cases where invoice details have been uploaded by the vendor but failed to remit the GST amount to GST department (form pmt-08 or form GST ret-01 to be submitted) within stipulated time, then GST paid on the invoices pertaining to the month for which GST return not fled by the vendor will be recovered from the vendor along with the applicable interest (currently 24% P.A) and all subsequent bills of the vendor will not be processed till filing of the GST return by the vendor

H. In case GST credit is denied to BHEL due to non-receipt or delayed receipt of goods and/ or tax invoice or expiry of timeline prescribed in GST law for availing such ITC, or any other reasons not attributable to BHEL, GST amount claimed in the invoice shall be disallowed to the vendor.

I. Where any GST liability arising on BHEL under reverse charge (RCM), the vendor has to submit the invoices to BHEL well within the timeline prescribed in GST law, to enable BHEL to discharge the GST liability. If there is a delay in submission of invoice by the vendor

 SOLAR BUSINESS DIVISION	NOTICE INVITING TENDER (NIT) Rev 00	TENDER NO. 278561
---	--	--------------------------

	<p>resulting in delayed payment of GST by BHEL along with interest, then such interest payable or paid shall be recovered from the vendor.</p> <p>J. GST TDS will be deducted as per section 51 of CGST act 2017 and in line with notification 50/2018 – central tax dated 13.09.2018. GST TDS certificate which will be generated in GST portal subsequent to vendor accepting the TDS deduction in the GST portal, will be issued to the vendor.</p>
20	<p>FORCE MAJEURE</p> <p>20.1 "Force Majeure" shall mean circumstance which is:</p> <ol style="list-style-type: none"> a) beyond control of either of the parties to contract, b) either of the parties could not reasonably have provided against the event before entering into the contract, c) having arisen, either of the parties could not reasonably have avoided or overcome, and d) is not substantially attributable to either of the parties <p>And</p> <p>Prevents the performance of the contract,</p> <p>Such circumstances include but shall not be limited to:</p> <ol style="list-style-type: none"> i) War, hostilities, invasion, act of foreign enemies. ii) Rebellion, terrorism, revolution, insurrection, military or usurped power, or civil war. iii) Riot, commotion or disorder by persons other than the contractor's personnel and other employees of the contractor and sub-contractors. iv) Strike or lockout not solely involving the contractor's personnel and other employees of the contractor and sub-contractors. v) Encountering munitions of war, explosive materials, ionizing radiation or contamination by radio-activity, except as may be attributable to the contractor's use of such munitions, explosives, radiation or radio- activity. vi) Natural catastrophes such as earthquake, tsunami, volcanic activity, hurricane or typhoon, flood, fire, cyclones etc. vii) Epidemic, pandemic etc. <p>20.2 The following events are explicitly excluded from Force Majeure and are solely the responsibilities of the non-performing party: a) any strike, work-to-rule action, go-slow or similar labour difficulty (b) late delivery of equipment or material (unless caused by Force Majeure event) and (c) economic hardship.</p> <p>20.3 If either party is prevented, hindered or delayed from or in performing any of its obligations under the Contract by an event of Force Majeure, then it shall notify the other in writing of the occurrence of such event and the circumstances thereof within 15 (fifteen) days after the occurrence of such event.</p> <p>20.4 The party who has given such notice shall be excused from the performance or punctual performance of its obligations under the Contract for so long as the relevant event of Force Majeure continues and to the extent that such party's performance is prevented, hindered or delayed. The Time for Completion shall be extended by a period of time equal to period of delay caused due to such Force Majeure event.</p> <p>20.5 Delay or non-performance by either party hereto caused by the occurrence of any event of Force Majeure shall not</p> <ol style="list-style-type: none"> i) Constitute a default or breach of the Contract. ii) Give rise to any claim for damages or additional cost expense occasioned thereby, if and to the extent that such delay or non-performance is caused by the occurrence of an event of Force Majeure.

 SOLAR BUSINESS DIVISION	NOTICE INVITING TENDER (NIT) Rev 00	TENDER NO. 278561
---	--	--------------------------

	<p>20.6 BHEL at its discretion may consider short closure of contract after 1 year of imposition of Force Majeure in line with extant guidelines. In any case, Supplier/Vendor cannot consider deemed short-closure after 1 year of imposition of Force Majeure</p>
21	<p>NO INTEREST PAYABLE TO CONTRACTOR Notwithstanding anything to the contrary contained in any other document comprising in the Contract, no interest shall be payable by BHEL to Contractor on any moneys or balances including but not limited to the Security Deposit, EMD, Retention Money, RA Bills or the Final Bill, or any amount withheld and/or appropriated by BHEL etc., which becomes or as the case may be, is adjudged to be due from BHEL to Contractor whether under the Contract or otherwise.</p>
22	<p>INTIMATION OF CHANGE OF NAME/ RE-CONSTITUTION OF THE ORGANIZATION In the event of the organization (Proprietorship/Partnership/Company) undergoing any change of name or reconstitution, prior intimation of the same shall be given to BHEL. Upon such changes coming into effect, the same is to be intimated to BHEL immediately with supporting documents as applicable.</p>
23	<p>INSURANCE:</p> <ol style="list-style-type: none"> i. BHEL/their customer shall arrange for insuring the materials/properties of BHEL/customer covering the risks during transit, storage, erection and commissioning. ii. It is the sole responsibility of the contractor to insure his materials, equipment, workmen etc. against accidents and injury while at work and to pay compensation, if any, to workmen as per Workmen’s compensation Act. The work will be carried out in a protected area and all the rules and regulations of the client /BHEL in the area of project which are in force from time to time will have to be followed by the contractor. iii. If due to negligence and or non-observation of safety and other precautions by the contractors, any accident/injury occurs to the property / manpower belong to third party, the contractor shall have to pay necessary compensation and other expense, if so decided by the appropriate authorities. iv. The contractor will take necessary precautions and due care to protect the material, while in his custody from any damage/ loss due to theft or otherwise till the same is taken over by BHEL or customer. For lodging / processing of insurance claim, the contractor will submit necessary documents. BHEL will recover the loss including the deductible franchise from the contractor, in case the damage / loss is due to carelessness / negligence on the part of the contractor. In case of any theft of material under contractor's custody, matter shall be reported to Police by the contractor immediately and copy of FIR and subsequently police investigation report shall be submitted to BHEL for taking up with insurance. However, this will not relieve the contractor of his contractual obligation for the material in his custody.
24	<p>LIMITATION ON LIABILITY: “Notwithstanding anything to the contrary in this Contract or LOA or Work Order or any other mutually agreed document between the parties, the maximum liability, for damages, of the contractor, its servants or agents, shall under no circumstances exceed an amount equal to the Price of the Contract or the Work Order. Neither party shall be liable to the other for any indirect or consequential loss or damage, including but not limited to loss of use, loss of profits,</p>

 <p>SOLAR BUSINESS DIVISION</p>	<p align="center">NOTICE INVITING TENDER (NIT) Rev 00</p>	<p align="center">TENDER NO. 278561</p>
---	--	--

	<p>or loss of contracts, or special, punitive, exemplary losses whatsoever, arising out of or in connection with this contract. This shall not be applicable on the recoveries made by Customer from BHEL on account of Contractor, any other type of recoveries for workmanship, material, T&P etc. due from the contractor.”</p>
25	Third Party Non-Disclosure Agreement (NDA) format
26	EFT Format
27	GCC (enclosed with NIT). In case of any conflict between the General Conditions of Contract and NIT Terms, provisions contained in the NIT terms shall prevail. Provisions contained in the Scope of works terms (Technical Specification and price BOQ) shall prevail over NIT Vol I and Vol II.

 <p>SOLAR BUSINESS DIVISION</p>	<p align="center">NOTICE INVITING TENDER (NIT) Rev 00</p>	<p align="center">TENDER NO. 278561</p>
---	--	--

Reverse Auction Form

Event Information

The “BHEL” has contracted to conduct this online bidding event. Service Provider shall answer all questions relating to the bidding process and conduct of the Reverse Auction Event.

1. Scheduled Date & Time of the event:

WILL BE INTIMATED BY

Any change in the scheduled time will be duly informed to you in advance.

2. Contact Information

“BHEL-SBD”

A. General Contract Related Queries

Name:

Designation:

Tel Nos.

E-mail ID:

Mobile No:

“Service Provider”

Software Related Queries/ Process related Queries

Name:

Designation:

Tel Nos.

E-mail ID:

TO BE INTIMATED LATER

 <p>SOLAR BUSINESS DIVISION</p>	<p align="center">NOTICE INVITING TENDER (NIT) Rev 00</p>	<p align="center">TENDER NO. 278561</p>
---	--	--

Process Compliance Form

To
Service Provider,

-----.

Sub: Agreement to the Process related Terms and Conditions

Dear Sir,

This has reference to the Terms & Conditions for the Reverse Auction mentioned in the bid document for ----- (Items) against BHEL Tender No. dated

This letter is to confirm that:

- 1) The undersigned is authorized official of the company.
- 2) We have studied the Reverse Auction Terms & Conditions and the Business rules governing the Reverse Auction as mentioned in your letter and confirm our agreement to them.
- 3) We also confirm that we have taken the training on the auction tool and have understood the functionality of the same thoroughly.

We, hereby confirm that we will honor the Bids placed by us during the auction process.

With regards

Signature with company seal -

Name –

Company / Organization –

Designation within Company / Organization –

Address of Company / Organization –

 <p>SOLAR BUSINESS DIVISION</p>	<p align="center">NOTICE INVITING TENDER (NIT) Rev 00</p>	<p align="center">TENDER NO. 278561</p>
---	--	--

THIRD PARTY NON-DISCLOSURE AGREEMENT

I, _____ on behalf of the _____ (Name of Company),

acknowledge that the information received or generated, directly or indirectly, while working with BHEL on contract is confidential and that the nature of the business of the BHEL is such that the following conditions are reasonable, and therefore:

I warrant and agree as follows:

I, or any other personnel employed or engaged by our company, agree not to disclose, directly or indirectly, any information related to the BHEL. Without restricting the generality of the foregoing, it is agreed that we will not disclose such information consisting but not necessarily limited to:

- Technical information: Methods, drawings, processes, formulae, compositions, systems, techniques, inventions, computer programs/data/configuration and research projects.
- Business information: Customer lists, project schedules, pricing data, estimates, financial or marketing data,

On conclusion of contract, I, or any other personnel employed or engaged by our company shall return to BHEL all documents and property of BHEL, including but not necessarily limited to: drawings, blueprints, reports, manuals, computer programs/data/configuration, and all other materials and all copies thereof relating in any way to BHEL's business, or in any way obtained by me during the course of contract. I further agree that I, or any others employed or engaged by our company shall not retain copies, notes or abstracts of the foregoing.

This obligation of confidence shall continue after the conclusion of the contract also.

I acknowledge that the aforesaid restrictions are necessary and fundamental to the business of the BHEL, and are reasonable given the nature of the business carried on by the BHEL. I agree that this agreement shall be governed by and construed in accordance with the laws of country.

I enter into this agreement totally voluntarily, with full knowledge of its meaning, and without duress.

Dated at....., this.....day of20 .

Name

Company

Signature

 SOLAR BUSINESS DIVISION	NOTICE INVITING TENDER (NIT) Rev 00	TENDER NO. 278561
---	--	--------------------------

Bank Detail (For EMD/SD submission as applicable): Bharat Heavy Electricals Limited Solar Business Division Prof. CNR Rao Circle Malleswaram Bengaluru-560012		
1	Name of the Beneficiary:	Bharat Heavy Electricals Limited
2	Name of the Bank & Branch:	IDBI Bank Limited, Trade Finance
3	Address of the Branch:	Trade Finance IDBI House,58, 1 st Floor, Mission road, Bengaluru-560027
4	Bank Telephone No:	080-2227 9576
5	NEFT IFSC code	IBKL0000377
6	Account Type:	Current
7	Account No.	008103000003605
8	RTGS IFSC code:	IBKL0000377

QR-CODE for EMD/SD Submission

Powered by



BHIM  **UPI** 

BHARAT INTERFACE FOR MONEY UNIFIED PAYMENTS INTERFACE

SCAN & PAY



1000200123000007.8792274550@idbi

BHARAT HEAVY ELECTRICALS LIMITED

Payment Accepted from all UPI Apps.

सभी UPI Apps से भुगतान स्वीकार किया जाता है।



**Electronic Funds Transfer (EFT) OR
Paylink Direct Credit Form**

Please Fill up the form in **CAPITAL LETTERS** only.

TYPE OF REQUEST(Tick one): _____ CREATE _____ CHANGE

BHEL Vendor / Supplier Code:	
Company Name :	
Permanent Account Number(PAN):	
Address	

City:	PINCODE	STATE
-------	---------	-------

Contact Person(s)	
Telephone No:	
Fax No:	
e-mail id:	

1 Bank Name:	
2 Bank Address:	
3 Bank Telephone No:	
4 Bank Account No:	
5 Account Type: Savings/Cash Credit	
6 9 Digit Code Number of Bank and branch appearing on MICR cheque issued by Bank	
7 Bank swift Code(applicable for EFT only)	
8 Bank IFSC code(applicable for RTGS)	
9 Bank IFSC code(applicable for NEFT)	

- A I hereby certify that the particulars given above are true, correct and complete and that I, as a representative for the above named Company, hereby authorise BHEL, SBD, Bangalore to electronically deposit payments to the designated bank account.
- B If the transaction is delayed or not effected at all for reasons of incomplete or incorrect information, I would not hold BHEL / transferring Bank responsible.
- C This authority remains in full force until BHEL, SBD, Bangalore receives written notification requesting a change or cancellation.
- D I have read the contents of the covering letter and agree to discharge the responsibility expected of me as a participant under ECS / EFT.

Date:

Authorised Signatory:

Designation:

Telephone NO. with STD Code

Company Seal

Bank Certificate

We certify that _____ has an Account No _____ with us and we confirm that the bank details given above are correct as per our records.

Date:

(.....)

Place:

Signature

In case of any query, please call Purchase Officer/ Contract Executive concerned at BHEL-SBD

BHEL DOCUMENT NUMBER: EN-TS-04-52-505-K-003



KAVACH PROJECT
 (The Indian Railway Automatic Train Protection System)

PACKAGE DETAILS Development of KAVACH
 System

PAGE 1 OF 24

DOCUMENT DESCRIPTION:

Specification of Type Testing of BHEL KAVACH System for Indian Railways

APPLICATION : BHEL KAVACH Systems

OEM/VENDOR  : Bharat Heavy Electricals Limited

END CLIENT  : Indian Railways

GC / Indian Railway APPROVAL

<input type="checkbox"/>	C. Notice of No Objection
<input type="checkbox"/>	B. No Objection with comments
<input type="checkbox"/>	A. Objection. A complete resubmission is required

Revision:	Rev 02		
Date of Issue:	14.03.2026		
Status:	For Approval		
Author(s):	Madhushree Pandey		
Reviewer(s):	VER 1 (Verifier): G V Raghavendra Babu VER 2 (Verifier):	Name of Validator /Safety Manager (VAL/SM):	G Sobha Rani
Project Manager (PM):	Ritesh R	Project Assessor (ASR)	ITCF

Additional Info

BHEL DOCUMENT NUMBER: EN-TS-04-52-505-K-003		
	KAVACH PROJECT The Indian Railway Automatic Train Protection System)	PAGE 2 OF 24
	PACKAGE DETAILS Development of KAVACH System	

Approved by	Name	Date	Signature
Reviewer 1 [VER]	G V Raghavendra Babu		
Reviewer 2 [VER]			
Quality Manager [QM]	Rajnish Chaudhary		
Validator [VAL]	G Sobha Rani		
Project Manager [PM]	Ritesh R		

BHEL DOCUMENT NUMBER: EN-TS-04-52-505-K-003		
	KAVACH PROJECT (The Indian Railway Automatic Train Protection System)	PAGE 3 OF 24
	PACKAGE DETAILS Development of KAVACH System	

History

Revision	Date	Description/Modification	Author/Authors
00	19.09.2025	Initial Draft	Madhushree Pandey, Sai Akhilesh
01	10.02.2026	First Submission	Madhushree Pandey
02	14.03.2026	Second Submission	Madhushree Pandey



BHEL DOCUMENT NUMBER: EN-TS-04-52-505-K-003		
	KAVACH PROJECT (The Indian Railway Automatic Train Protection System)	PAGE 4 OF 24
	PACKAGE DETAILS Development of KAVACH System	

TABLE OF CONTENTS

1	INTRODUCTION.....	6
1.1	Purpose of this Document	6
1.2	General Instructions	6
1.3	Scope of the Project	7
	Norms and Standards	7
1.3.1	Input Documents.....	8
1.3.2	Referenced Documents	8
1.4	Abbreviations and Acronyms.....	8
1.5	Terms and Definitions.....	9
2.	DETAILED TECHNICAL FEATURES	11
2.1.	BSKS: BHEL Stationary Kavach System	11
2.2.	BRIKS: BHEL Remote Interface Kavach System.....	14
2.3.	BOKS- BHEL Onboard Kavach System	16
3.	PRE-QUALIFYING REQUIREMENTS/ ELIGIBILITY CRITERIA.....	19
4.	DETAILED SCOPE OF WORK.....	21
5.	VALIDITY	22
6.	PRICE VARIATION CLAUSE (PVC).....	23
7.	PAYMENT TERMS	23
8.	DELIVERABLES	23
9.	DELIVERY PERIOD.....	23
10.	LIQUIDATED DAMAGES:.....	24
11.	TYPE TESTS: ANNEXURE-1	24

BHEL DOCUMENT NUMBER: EN-TS-04-52-505-K-003		
	KAVACH PROJECT (The Indian Railway Automatic Train Protection System)	PAGE 5 OF 24
	PACKAGE DETAILS Development of KAVACH System	

List of Tables

Table 1: Norms and Standards	7
Table 2: Input Documents	8
Table 3: Referenced Documents	8
Table 4: Abbreviations and Acronyms.....	8
Table 5: Terms and Definitions	9

BHEL DOCUMENT NUMBER: EN-TS-04-52-505-K-003		
	KAVACH PROJECT (The Indian Railway Automatic Train Protection System)	PAGE 6 OF 24
	PACKAGE DETAILS Development of KAVACH System	

1 INTRODUCTION

KAVACH is an indigenously developed Automatic Train Protection (ATP) system meant to provide protection to the trains against Signal Passing at Danger (SPAD), excessive speed and collisions. KAVACH provides protection to the trains against Signal Passing at Danger (SPAD), excessive speed and collisions. KAVACH provides continuous update of Movement Authority (distance up to which the train is permitted to travel without danger). Hence during unsafe situations when brake application is necessitated, and the crew has either failed to do so, or is not in position to do so, automatic brake application shall take place. KAVACH has additional features to display information like speed, location, distance to signal ahead, Signal aspects etc. in Locomotive cab and generation of Auto and Manual SOS messages (Distress messages) from Locomotive as well as from the Station unit in case of emergency situation. The Communication between Stationary KAVACH and Loco KAVACH units shall be Safety Integrity Level-4(SIL4) certified as per the CENELEC standards for railways.

1.1 PURPOSE OF THIS DOCUMENT

This specification covers the technical requirements of Type Testing for BHEL KAVACH systems as per RDSO System Requirement Specification: RDSO/SPN/196/2020 Version 4.0 d3 & RDSO/SPN/144 Rev 02

1.2 GENERAL INSTRUCTIONS:

The Testing agency shall submit the offer / bids in two parts:

Part 1: Techno-commercial bid (without pricing). Unpriced bid to be enclosed with the technical bid.

Part 2: Price bid

BHEL DOCUMENT NUMBER: EN-TS-04-52-505-K-003		
	KAVACH PROJECT (The Indian Railway Automatic Train Protection System)	PAGE 7 OF 24
	PACKAGE DETAILS Development of KAVACH System	

1.3 SCOPE OF THE PROJECT

Scope of this project includes Developmental, Environmental & EMI-EMC Testing of following BHEL KAVACH Panels and its accessories as per this specification. This shall consist of following panels.

1. BHEL Stationary KAVACH System (BSKS) & accessories
2. BHEL Onboard KAVACH System (BOKS) & accessories
3. BHEL Remote Interface KAVACH System (BRIKS) & accessories

NORMS AND STANDARDS

Table 1: Norms and Standards

Reference	Title	Edition
IS: 9000	Basic environmental testing procedures for electronic and electrical items	
EN 50155 standard	Railway applications- Rolling stock- Electronic Equipment	-
EN 61010-1 2010 standard	specifies general safety requirements for the following types of electrical equipment and their accessories, wherever they are intended to be used	-
IEC 61373	Railway applications - Rolling stock equipment - Shock and vibration tests	-
ELRS/SPEC/S1/0015	Reliability of electronics used in rolling stock application	
EN 50121-4	Railway Applications -Electromagnetic Compatibility (EMC)	
IEC 60571:2012	Railway applications - Electronic equipment used on rolling stock	
IEC 61000-4.29	Electromagnetic compatibility : Testing and measurement Techniques	
IEC 62236-3-2	Railway Application- Electromagnetic Compatibility- Rolling stock	

BHEL DOCUMENT NUMBER: EN-TS-04-52-505-K-003		
	KAVACH PROJECT (The Indian Railway Automatic Train Protection System)	PAGE 8 OF 24
	PACKAGE DETAILS Development of KAVACH System	

1.3.1 INPUT DOCUMENTS

Table 2: Input Documents

Title
SRS: System Requirement Specification of KAVACH (The Indian Railway Automatic Train Protection System) - RDSO/SPN/196/2020 Version 4.0 d3 or its latest along with its associated annexures
RDSO/SPN/144/ 2006 or latest- Safety and reliability requirement of electronic signalling equipment
IS: 9000 Basic environmental testing procedures for electronic and electrical items

1.3.2 REFERENCED DOCUMENTS

Table 3: Referenced Documents

Title	Version
System Requirement Specification of KAVACH (The Indian Railway Automatic Train Protection System) - RDSO/SPN/196/2020 Version 4.0 d3 or its latest along with its associated annexures.	4.0 Amdt -3
Safety and reliability requirement of Electronic signalling equipment- RDSO/ SPN/ 144/2006 or latest along with its associated annexures.	Revision: 2

1.4 ABBREVIATIONS AND ACRONYMS

Table 4: Abbreviations and Acronyms

Abbreviation/ Acronym	Definition/Description
TCAS	Train collision avoidance system
ATP	Automatic Train Protection
RDSO	Research Designs & Standards organization
EMC/ EMI	Electromagnetic compatibility/ Electromagnetic Interference
EN	European standard

BHEL DOCUMENT NUMBER: EN-TS-04-52-505-K-003		
	KAVACH PROJECT (The Indian Railway Automatic Train Protection System)	PAGE 9 OF 24
	PACKAGE DETAILS Development of KAVACH System	

Abbreviation/ Acronym	Definition/Description
MTBF	Mean Time Between Failure
PD	Pollution Degree
MCB	Miniature Circuit Breaker
ISO	International Organization for Standardization
OEM	Original Equipment Manufacturer
SIL	Safety integrity level
IEC	International Electrotechnical Commission
BSKS	BHEL Stationary KAVACH System
BRIKS	BHEL Remote Interface KAVACH System
BOKS	BHEL Onboard KAVACH System

1.5 TERMS AND DEFINITIONS

The following table describes or defines terms which are used within this document to get a better understanding or if the term is used in a specific way to avoid misunderstandings.

Table 5: Terms and Definitions

Term	Definition/Description
PM	Project manager
RQM	Requirements manager
DES	Designer
VER	Verifier
VAL	Validator
TST	Tester
INT	Integrator
IMP	Implementor

BHEL DOCUMENT NUMBER: EN-TS-04-52-505-K-003		
	KAVACH PROJECT (The Indian Railway Automatic Train Protection System) PACKAGE DETAILS Development of KAVACH System	PAGE 10 OF 24

This page is intentionally left blank

BHEL DOCUMENT NUMBER: EN-TS-04-52-505-K-003		
	KAVACH PROJECT (The Indian Railway Automatic Train Protection System)	
	PACKAGE DETAILS Development of KAVACH System	PAGE 11 OF 24

2. DETAILED TECHNICAL FEATURES

2.1. BSKS: BHEL STATIONARY KAVACH PANEL

Stationary Kavach

Tentative weight of the assembled panel: approx. 240 kg

Panel Dimension: 650 x 450 x 1600 mm

Input Voltage: 110 V DC

Input Current: 6 A

Output Voltage: 24 V DC

Output Current: 20 A

Location: Inside Station (Indoor)

Operating Environment: Ground Stationary

Fig 1: Front view of Stationary kavach Panel (Indicative)

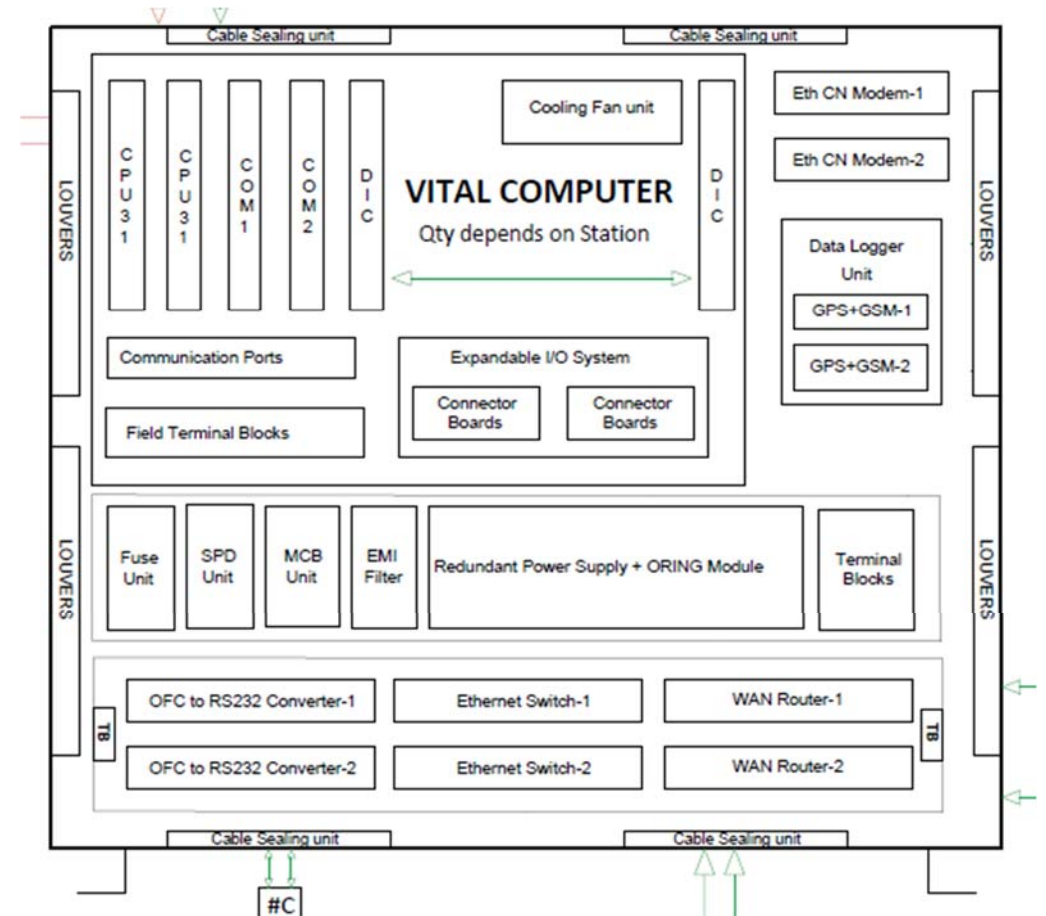

BHEL DOCUMENT NUMBER: EN-TS-04-52-505-K-003		
	KAVACH PROJECT (The Indian Railway Automatic Train Protection System)	
	PACKAGE DETAILS Development of KAVACH System	PAGE 12 OF 24

Stationary KAVACH associated sub-systems

Sl No	Item	Weight (Kg)	Dimensions (LXWXH mm)
1	SKAVACH Panel	240	650 x 450 x 1600
2	Station Master – Operation Cum Indication Panel (SM-OCIP)	6.5	220 x 200 x 162
3	RFID Tags	Without enclosure: 0.175 kg	Without enclosure: 236 x 35 x 20
		With enclosure and clamps: 3 Kg	With enclosure: 300 x 150 x 68
4	UHF Antenna	0.8 Kg	320 x 280 x 90
5	Global Positioning System (GPS) / Global navigation satellite system (GNSS) /GSM Antenna / LTE Antenna	1 Kg	260 x 85 x 110



BHEL DOCUMENT NUMBER: EN-TS-04-52-505-K-003		
	KAVACH PROJECT (The Indian Railway Automatic Train Protection System)	PAGE 13 OF 24
	PACKAGE DETAILS Development of KAVACH System	

Fig 2: Different views of Stationary kavach Panel (General Arrangement)

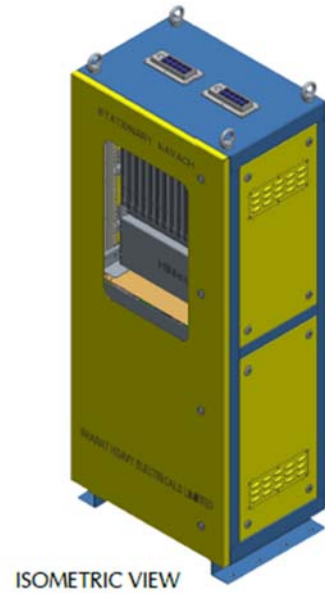

BHEL DOCUMENT NUMBER: EN-TS-04-52-505-K-003		
	KAVACH PROJECT (The Indian Railway Automatic Train Protection System)	PAGE 14 OF 24
	PACKAGE DETAILS Development of KAVACH System	

2.2. BRIKS: BHEL REMOTE INTERFACE KAVACH SYSTEM

Panel Dimension: 650 x 450 x 950 mm

Input Voltage: 230 V AC

Input Current: <=5 A

Output Voltage: 24 V DC

Output Current: <=10 A

Location: Location box/ OFC huts (Outdoor-inside Location Box/ Indoor- OFC huts)

Operating Environment: Ground Stationary

Sl No	Item	Weight (Kg)	Dimensions (LXWXH mm)
1	RIU Panel	150 Approx	650 x 450 x 950 mm-tentative

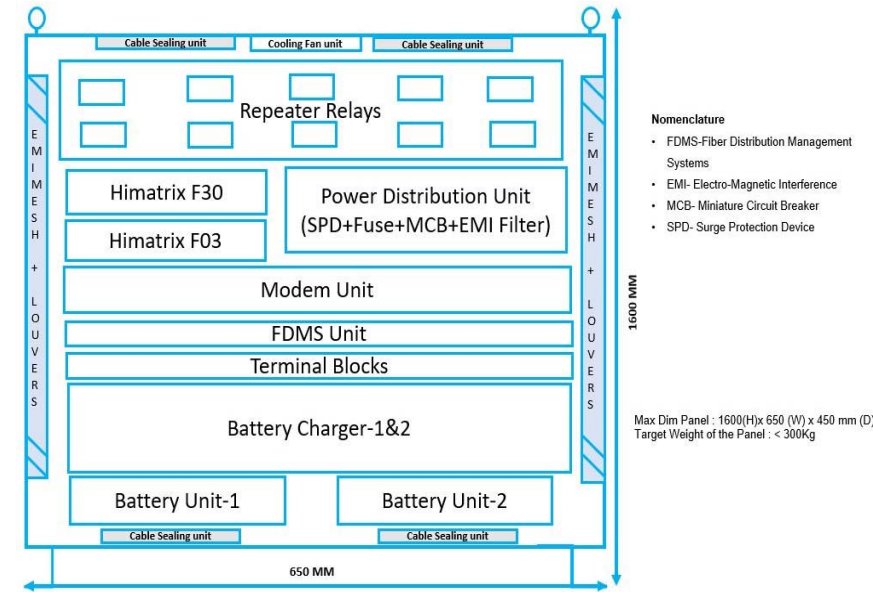

Fig 3: Front view of Remote Interface kavach Panel

BHEL DOCUMENT NUMBER: EN-TS-04-52-505-K-003		
	KAVACH PROJECT (The Indian Railway Automatic Train Protection System)	PAGE 15 OF 24
	PACKAGE DETAILS Development of KAVACH System	

Fig 5: Different views of Remote Interface kavach Panel



LEFT SIDE VIEW

ISOMETRIC VIEW

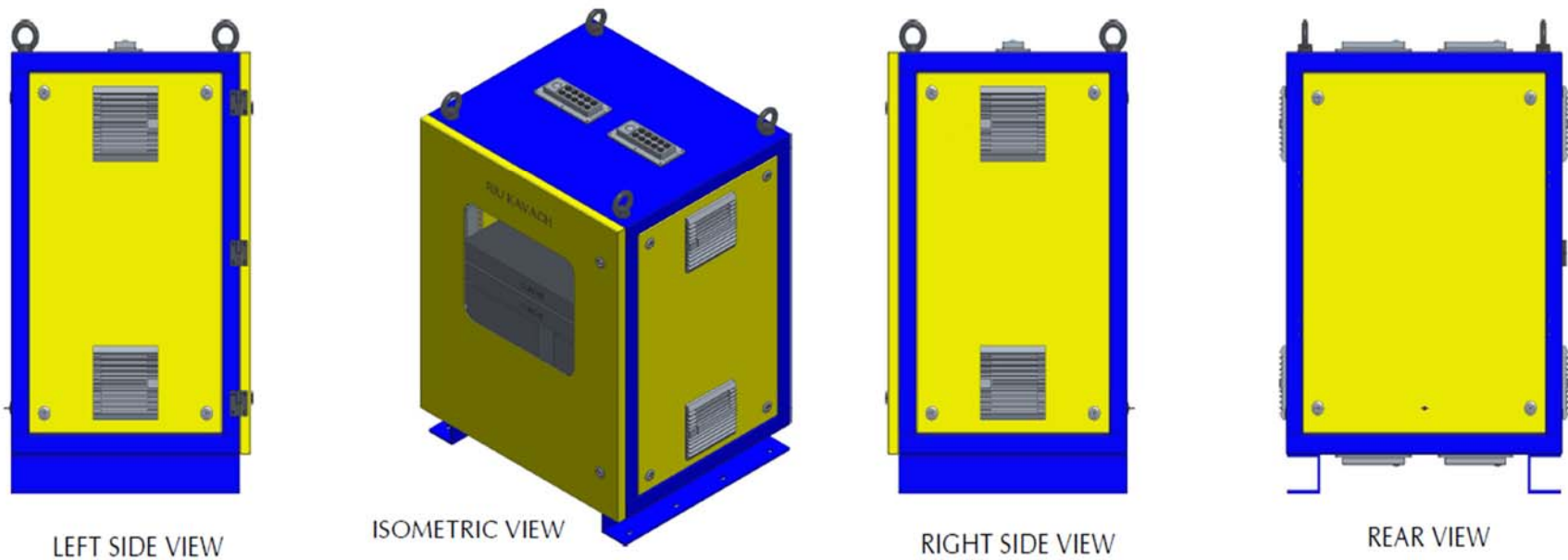
RIGHT SIDE VIEW

REAR VIEW

BHEL DOCUMENT NUMBER: EN-TS-04-52-505-K-003		
	KAVACH PROJECT The Indian Railway Automatic Train Protection System)	
	PACKAGE DETAILS Development of KAVACH System	PAGE 16 OF 24

2.3. BOKS- BHEL ONBOARD KAVACH PANEL AND ITS ASSOCIATED SUB-SYSTEMS

Tentative weight of the assembled panel: approx. 198 kg

Panel Dimension: 650 x 435 x 1150 mm

Input Voltage: 110 V DC

Input Current: 5 A

Output Voltage: 110 V DC/ 24 V DC

Output Current: 5 A

Location: Inside Locomotive (Indoor)

Operating Environment: Ground Mobile

Sl No	Item	Weight (Kg)	Dimensions (LXWXH mm)
1	On board Panel	198	650 x 435 x 1150
2	Driver Machine Interface (LP-OCIP)	9.5	337 x 120 x 31.8
3	RFID Reader	Reader with enclosure: 9.8	Reader with enclosure: 336 x 424 x 145
		Reader with enclosure and mounting: 23.6	Reader with enclosure and mounting: 700 x 424 x 550
		Bare Reader: 2.8	Bare Reader: 200 x 320 x 100 mm
4	UHF Antenna	0.5	150 x 80 x 140
5	Global Positioning System (GPS) / Global navigation satellite system (GNSS) /GSM Antenna / LTE Antenna	1	260 x 85 x 110
6	Pulse generators	2.5	155 x 200 x 70
7	Brake Interface Unit (E-70/CCB/IRAB)	50	305 x 160 x 230

BHEL DOCUMENT NUMBER: EN-TS-04-52-505-K-003		
	KAVACH PROJECT (The Indian Railway Automatic Train Protection System)	PAGE 17 OF 24
	PACKAGE DETAILS Development of KAVACH System	

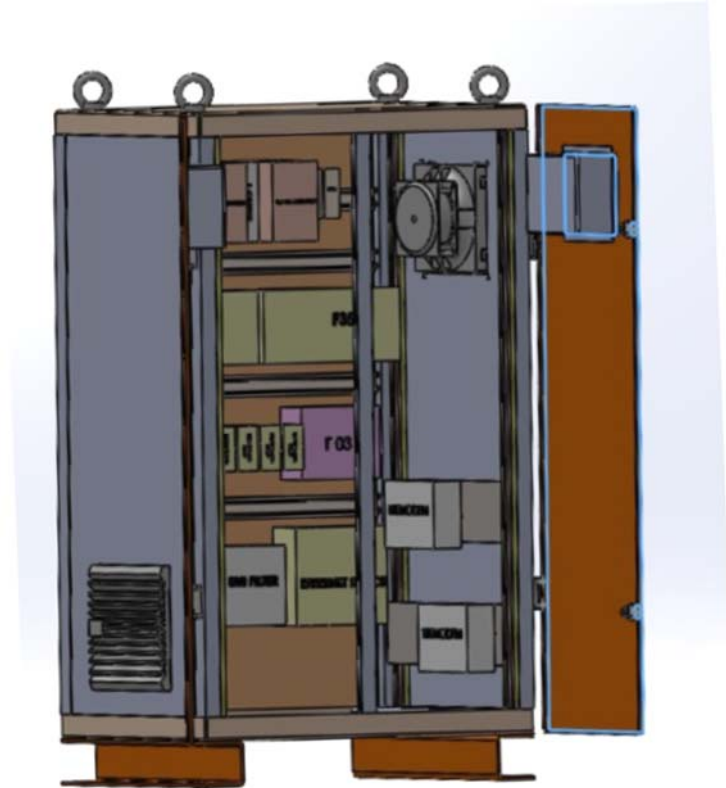
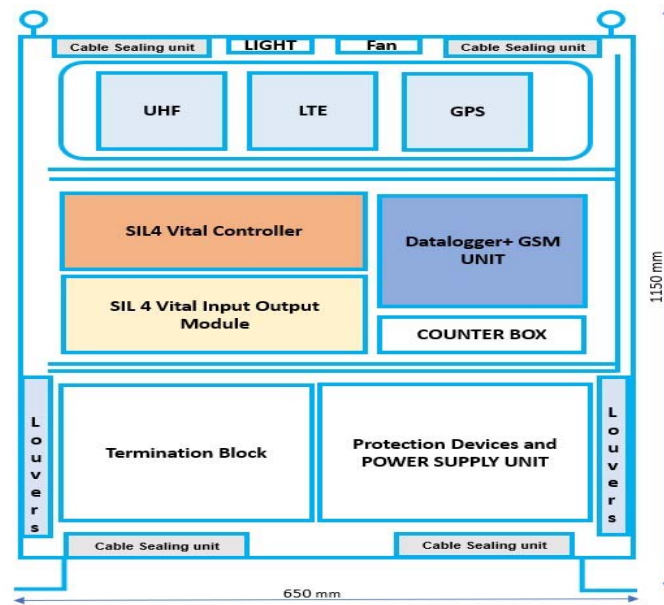



Fig 6: Front view of Onboard kavach Panel (Indicative)
 Fig 7: Front view of Onboard kavach Panel (General Arrangement)

BHEL DOCUMENT NUMBER: EN-TS-04-52-505-K-003		
	KAVACH PROJECT (The Indian Railway Automatic Train Protection System)	PAGE 18 OF 24
	PACKAGE DETAILS Development of KAVACH System	

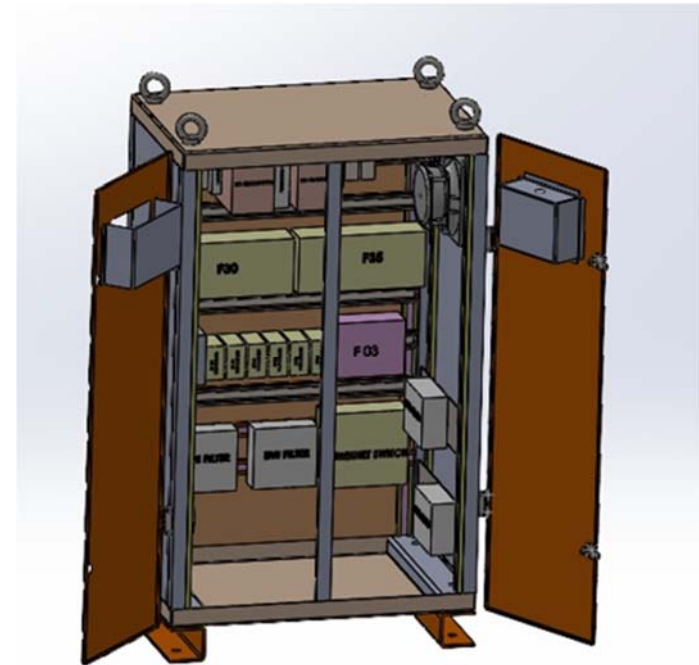
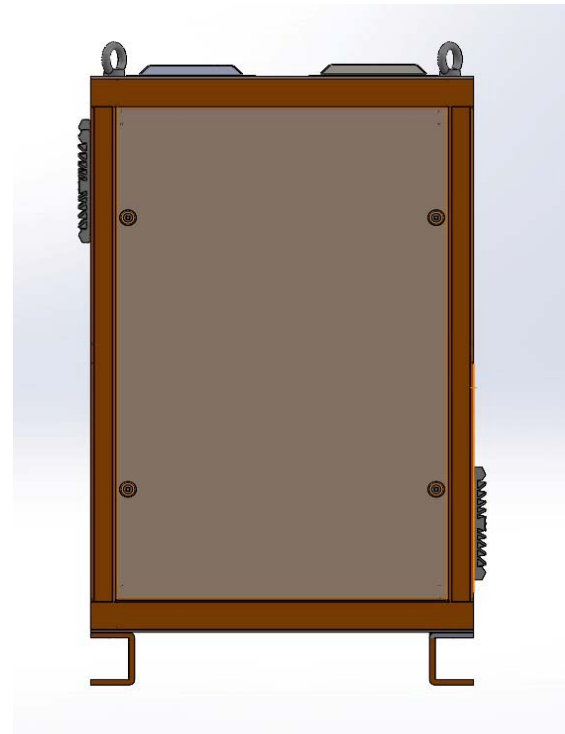
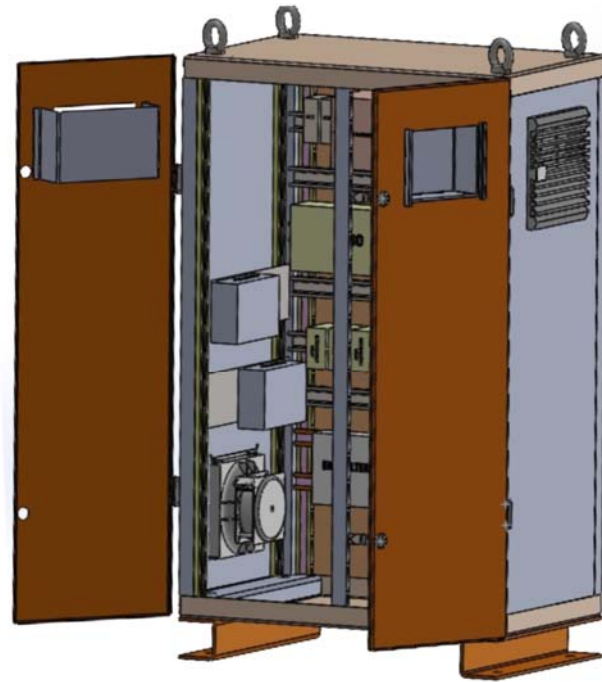



Fig 8: Different views of Onboard kavach Panel

BHEL DOCUMENT NUMBER: EN-TS-04-52-505-K-003		
	KAVACH PROJECT (The Indian Railway Automatic Train Protection System)	
	PACKAGE DETAILS Development of KAVACH System	PAGE 19 OF 24

3. PRE-QUALIFYING REQUIREMENTS/ ELIGIBILITY CRITERIA

Type Testing Agency / Laboratory shall comply the following.

BHEL Requirement	Documents to be submitted for evaluation along with the technical offer
1. The bidder shall be an NABL-accredited Testing Laboratory as per ISO/IEC 17025	NABL Accreditation Certificate as per ISO/IEC 17025
2. The bidder shall have experience in testing and successful completion of Type testing of kavach panels as per applicable IS/IEC standards (as per annexure-1, which is in accordance with RDSO specifications: RDSO/SPN/196/2020 version 4, amendment 3 effective from 07.06.2024 or latest or KAVACH Version 3.2 & acceptance test format for kavach as per RDSO/SPN/196/2020 (version 4.0) effective from 08.11.2024 or latest & specification for safety and reliability requirement of electronic signalling equipment - RDSO/ SPN/ 144/2006 Revision 2 effective from 14.03.2006 or latest)	<p>Purchase order(s) or proof of services or Invoices or Test Reports to be submitted for similar works* conducted within last five years from the date of tender.</p> <p>*Similar works is defined as service delivery to Railways or RDSO or RDSO Approved KAVACH Vendors or RDSO Approved KAVACH Developmental Vendors.</p>

BHEL DOCUMENT NUMBER: EN-TS-04-52-505-K-003		
	KAVACH PROJECT (The Indian Railway Automatic Train Protection System)	
	PACKAGE DETAILS Development of KAVACH System	PAGE 20 OF 24

<p>3. Average Annual financial turnover during the last 3 years, ending 31st March of the previous financial year, should be at least ₹ 10.65 Lacs/-</p>	<p>Bidder shall submit the audited balance sheet and profit & Loss account OR Certificate from Chartered Accountant for the audited last two FY.</p>
<p>4. The selected lab should be capable of carrying out in-house, at least 50 % tests as specified in annexure-1. If required other tests, for which facility is not available at parent lab, may be offloaded to any other NABL accredited lab / Government lab (offloading limited to one lab only) for which qualification criteria will be NABL Accreditation Certificate as per ISO/IEC 17025. However, all responsibility for offloaded tests and their appropriate test report shall rest with parent lab. Credentials of the outsourced labs to be submitted in bid.</p>	<p>1. Self-certification in case of 100 % inhouse testing. or 2. For offloaded laboratory, NABL Accreditation Certificate as per ISO/IEC 17025.</p>

BHEL DOCUMENT NUMBER: EN-TS-04-52-505-K-003		
	KAVACH PROJECT (The Indian Railway Automatic Train Protection System)	
	PACKAGE DETAILS Development of KAVACH System	PAGE 21 OF 24

4. DETAILED SCOPE OF WORK

To and fro transport cost and transit insurance for all equipment under test (EUT) shall be borne by BHEL. Handling of equipment at test lab shall be responsibility of lab. L1 vendor shall be decided based on total package price of testing charges of all items including development charges, i.e. Annexure-1.

- Development charge for EMI/EMC: Bidder shall carry out EMI/EMC testing as per annexure-1 and shall allow BHEL to do required correction before carrying out final testing.
- Lab shall provide assistance in the form of tools and tackles or man power for minor corrections in equipment under test, required during testing.
- Power supply availability and other assistance required during functional test which is part of Type Testing shall be in Lab scope.

The laboratory shall be capable of facilitating functional/ performance/ interface & operational checks as required during Type Testing of KAVACH Panels.

Following procedure shall be followed.

1) At the time of bid submission

Test lab shall submit the company's ISO certificate, NABL Accreditation, list of apparatus along with their calibration certificate and other required documents for BHEL review. Also, type testing agency shall submit the necessary dimensions available for the chamber along with weight limitations and single point of contact for coordination for performing the tests. Test lab shall submit test plan and time schedule for each test after equipment are made available at test lab i.e. Complete schedule of testing including outsourced tests along with their place of testing shall be clearly brought out in the bid.

BHEL DOCUMENT NUMBER: EN-TS-04-52-505-K-003		
	KAVACH PROJECT (The Indian Railway Automatic Train Protection System)	
	PACKAGE DETAILS Development of KAVACH System	PAGE 22 OF 24

2) After placement of work order

Test lab shall give detailed plan for Annexure 1 which should also mention the duration of all the tests along with slots for performing the tests. As per the plan agreed mutually between BHEL and Test lab, BHEL shall deliver 1 set of panels of each type as described in clause 2.0 to the type testing location which shall be kept in safe location by test lab.

BHEL along with RDSO may be witnessing the tests performed and shall verify the setup before the start of the test. If any test started, without the consent of BHEL and RDSO, it will be re-performed at the scope of Type testing agency without any additional cost.

Test lab shall submit the reports and observations for each test in a format that is mutually agreed between BHEL and test lab.

Repetition of test due to test lab's lack of some items required for testing or lack of test apparatus during testing slot failure or malfunctioning or lack of coordination shall be borne by test lab.

5. VALIDITY

- VALIDITY OF OFFER: The offer shall be valid for minimum of 180 days from the date of bid opening.
- VALIDITY OF PURCHASE ORDER: The Purchase Order shall be valid for one year from the date of placement of Order.

BHEL DOCUMENT NUMBER: EN-TS-04-52-505-K-003		
	KAVACH PROJECT The Indian Railway Automatic Train Protection System)	
	PACKAGE DETAILS Development of KAVACH System	PAGE 23 OF 24

6. PRICE VARIATION CLAUSE (PVC)

The prices shall be firm and fixed till validity of Purchase Order. PVC is not applicable.

7. PAYMENT TERMS

- Payment will be made on completion of each milestone as below on successful completion & certification from BHEL in charge.
 - a. **Milestone 1: Completion of Developmental Tests (SI No I of Annexure-1)**
 - b. **Milestone 2: Completion of Environmental Tests (SI No II of Annexure-1)**
 - c. **Milestone 3: Completion of EMI/ EMC Tests (SI No III of Annexure-1)**

Payment shall be as per BHEL standard payment terms & conditions as mentioned in GCC.

8. DELIVERABLES

Final test reports / certifications for tests conducted as per BHEL Specification.

9. DELIVERY PERIOD

BHEL shall provide equipment/ panels and accessories to be tested to the laboratory. Laboratory shall complete testing within 120 days of delivery of equipments to laboratory.

BHEL DOCUMENT NUMBER: EN-TS-04-52-505-K-003		
	KAVACH PROJECT (The Indian Railway Automatic Train Protection System)	
	PACKAGE DETAILS Development of KAVACH System	PAGE 24 OF 24

10. LIQUIDATED DAMAGES:

Delivery period will start from delivery of equipment to test lab and considered complete on finishing of testing activity. Testing has to be completed within 120 days from the date of equipment delivery by BHEL to Test Laboratory. However, any delay on account of BHEL shall not be included for calculation of delivery period. This shall be based on certification from BHEL in Charge. Liquidated Damages shall be applicable as per BHEL standard terms and condition.

LD shall be 0.5 % of contract value per week for delay beyond 120 days for test completion (as per annexure 1) from the date of equipment delivery to Test laboratory for reasons attributable to laboratory. This LD shall be maximum of 10% of the contract value.

11. TYPE TESTS: ANNEXURE-1

As per Annexure-1 attached herewith. This is in line with Clause 22 of RDSO System requirement Specification No RDSO/196/2020 Version 4.0 & its Type Test format.

KAVACH PROJECT
PACKAGE DETAILS Development of KAVACH System-Type Certification
BHEL DOCUMENT NUMBER: EN-TS-04-52-505-K-003 Annexure 1

SI No	Test Category	Type of Test	Equipment Condition	SKAVACH	ONBOARD KAVACH	RIU	Separately for other Sub Systems	Requirement	Severity	Specification	UOM	Qty
I	Developmental Tests	As per SI No III- 1,2,3,4,5,6	Operating	x	✓	x	✓	1. System shall be fully functional during test. 2. No apparent damage or deterioration should be observed during physical check, after completion of test and standard recovery. 3. After completion of the test, the equipment shall be tested for its nominal	As per SI No III- 1,2,3,4,5,6	As per SI No III- 1,2,3,4,5,6	Set	1
II	Environmental/ Climatic Test											
1a	Environmental Reliability Test	Dry heat test (Operation)	Operating	✓	✓	✓	✓	1. The system shall be fully functional during the test. 2. At the end of the test, the interconnected system shall be tested as mentioned in 7.5 of System level functional testing (Integrated) (before Environmental) of document Ref: Type Test Format for KAVACH Hardware of M/S Firm's Name. 3. No apparent damage or deterioration should be observed during the physical check, after completion of the test and standard recovery.	For functional trials: Temp. 70 °C, Duration: 16 hrs.	IS: 9000 Pt.III Section: V	Set	1
1b	Environmental Reliability Test	Dry heat test (Storage)	Non Operating	✓	✓	✓	✓	1. The system shall be switched off during the test. 2. At the end of the test, the interconnected system shall be tested as mentioned in 7.5 of System level functional testing (Integrated) (before Environmental) of document Ref: Type Test Format for KAVACH Hardware of M/S Firm's Name. 3. No apparent damage or deterioration should be observed during the physical check, after completion of the test and standard recovery.	Temp. 75 °C, Duration: 16 hrs.	IS: 9000 Pt.III Section: V	Set	1
2	Environmental Reliability Test	Cold Test (Operation)	Operating	✓	✓	✓	✓	1. The system shall be fully functional during the test. 2. At the end of the test, the interconnected system shall be tested as mentioned in 7.5 of System level functional testing (Integrated) (before Environmental) of document Ref: Type Test Format for KAVACH Hardware of M/S Firm's Name. 3. No apparent damage or deterioration should be observed during the physical check, after completion of the test and standard recovery.	Temp. -10 °C ± 3 °C, Duration: 2 hrs.	IS: 9000, Pt. II	Set	1
3	Environmental Reliability Test	Rapid Variation Temperature Test/ Change of Temp Test	Operating	✓	✓	✓	✓	1. The system shall be fully functional during the test. 2. At the end of the test, the interconnected system shall be tested as mentioned in 7.5 of System level functional testing (Integrated) (before Environmental) of document Ref: Type Test Format for KAVACH Hardware of M/S Firm's Name. 3. No apparent damage or deterioration should be observed during the physical check, after completion of the test and standard recovery.	-10 ±3 °C to +70 °C±2 °C, Duration: 7 hrs at each temperature. Rate of change: 1°C per Minute. No. of cycle: 03	IS: 9000 Pt. XIV Section: II	Set	1
4	Environmental Reliability Test	Damp heat test (steady state storage)	Operating	✓	✓	✓	✓	1. The system shall be fully functional during the test. 2. At the end of the test, the interconnected system shall be tested as mentioned in 7.5 of System level functional testing (Integrated) (before Environmental) of document Ref: Type Test Format for KAVACH Hardware of M/S Firm's Name. 3. No apparent damage or deterioration should be observed during the physical check, after completion of the test and standard recovery.	RH 93% (+2 %, -3%) @ 40 °C±2 °C Duration = 4 days	IS: 9000 Pt. IV	Set	1
5	Environmental Reliability Test	Damp heat test (Cyclic)	Operating (Fully functional during one-hour period towards end of each cycle. Stabilization shall be done at 25°C ±30C.)	✓	✓	✓	✓	1. The system shall be fully functional during the test. 2. At the end of the test, the interconnected system shall be tested as mentioned in 7.5 of System level functional testing (Integrated) (before Environmental) of document Ref: Type Test Format for KAVACH Hardware of M/S Firm's Name. 3. No apparent damage or deterioration should be observed during the physical check, after completion of the test and standard recovery.	RH 95% (+1 %, -5%) @ 40 °C ±2 °C (high), 25 °C (low)Duration: 12 + 12 = 24 hrs. cyclic No. of cycles = 6 (Fully functional during one hour period toward end of each cycle. Stabilisation shall be done at 25± 3°C).	IS: 9000 Pt. V Section-II	Set	1
6	Environmental Reliability Test	Bump Test (Package)	Non-operating	✓	✓	✓	✓	1. Modules/ Units shall be in packed condition during the test. 2. No apparent damage or deterioration should be observed. 3. After completion of the test, the equipment shall be tested for its nominal operation as per 7.5 of System level functional testing (Integrated) (before Environmental) of document Ref: Type Test Format for KAVACH Hardware of M/S Firm's Name.	Peak acceleration 400 m/s ² or 40g, 1000 bumps per axis Duration: 6 milliseconds No. of axes: 03	IS: 9000 Pt. VII Section II	Set	1
7a	Environmental Reliability Test	Mechanical Shock	Power off Condition (At the end of the test, the assembly shall be subjected to performance test)	✓	✓	✓	RFID Reader, Radio Antenna, GPS & GSM Antenna, Radio Modem, DMI, SMOICP, BIU, Pulse Generator	1. The system shall be switched off during the test. 2. No apparent damage or deterioration should be observed. 3. After completion of the test, the equipment shall be tested for its nominal operation as per 7.5 of System level functional testing (Integrated) (before Environmental) of document Ref: Type Test Format for KAVACH Hardware of M/S Firm's Name.	Peak acceleration: 20g Pulse Duration: 11 millisecond (Half sine pulse). Total No. of shocks: 18 No. of axes: 3 shocks in each direction Equipment in unpacked condition shall be subjected Mechanical Shock. In addition to physical checks, the assembly shall be subjected to performance test.	IS: 9000 Pt. VII , Section-I or IEC 60068-2-27 -2008	Set	1

KAVACH PROJECT
PACKAGE DETAILS Development of KAVACH System-Type Certification
BHEL DOCUMENT NUMBER: EN-TS-04-52-505-K-003 Annexure 1

7b	Environmental Reliability Test	Mechanical Shock	Power off Condition (At the end of the test, the assembly shall be subjected to performance test)	x	x	x	RFID Tag	1. The system shall be switched off during the test. 2. No apparent damage or deterioration should be observed. 3. Equipment in unpacked condition shall be subjected to Bump test. In addition to physical checks, the equipment shall be tested for its nominal operation as per 7.5 of System level functional testing (Integrated) (before Environmental) of document Ref: Type Test Format for KAVACH Hardware of M/S Firm's Name.	Peak acceleration: 40 g. Duration of the pulse: 11 m.sec. No. of shocks: 18 Velocity change : Half sine pulse	IS 9000 Part VII Sec. 1 Clause 9	Set	1
8a	Environmental Reliability Test	Vibration test	Non Operating	✓		✓	SMOCIP, Radio Modem, Radio Antenna, RFID Tag	1. No apparent damage or deterioration should be observed during physical check, after completion of test. 2. After completion of the test, the equipment shall be tested for its nominal operation as per 7.5 of System level functional testing (Integrated) (before Environmental) of document Ref: Type Test Format for KAVACH Hardware of M/S Firm's Name.	Freq. Range: 5 Hz to 350 Hz Acceleration: 2 g No. Of Axis: 3 No. Of Sweep cycles: 20 Total Duration: 105 min/axis If resonance is observed: 10 minutes at each resonant frequency.	IS: 9001 Pt. XIII	Set	1
8b	Environmental Reliability Test	Vibration test	Non Operating		✓		DMI, RFID Reader,GPS & GSM Antenna, BIU,Pulse Generator	1. No apparent damage or deterioration should be observed during physical check, after completion of test. 2. After completion of the test, the equipment shall be tested for its nominal operation as per 7.5 of System level functional testing (Integrated) (before Environmental) of document Ref: Type Test Format for KAVACH Hardware of M/S Firm's Name.	Freq. Range: 5 Hz to 150 Hz Acceleration: 3 g. No. Of Axis: 3 No. of Sweep cycles: 20 Total Duration: 105 min/axis If resonance is observed: 10 minutes at each resonant frequency.	IS: 9001 Pt. XIII	Set	1
9a	Environmental Reliability Test	Salt Mist Test-On Board (inside cab) & Indoor	Non Operating	x	✓	x	DMI, BIU, Radio Unit & SMOCIP	1. The system shall be switched off during the test. 2. No apparent damage or deterioration should be observed. 3. After completion of the test, the equipment shall be tested for its nominal operation as per document Ref: Type Test Format for KAVACH Hardware of M/S Firm's Name.	Procedure 3: Salt Duration: 2hrs, Mist Duration =22 hours 35± 3°C, RH: 93% (+2, -3%) No. of cycles: 03	IS: 9000 Pt. XI	Set	1
9b	Environmental Reliability Test	Salt Mist Test- On Board (outside cab) & Outdoor (On Track /Track side)	Non Operating	x	✓	x	RFID Reader, Radio Antenna, GPS & GSM Antenna,Pulse Generator, RFID Tag	1. The system shall be switched off during the test. 2. No apparent damage or deterioration should be observed. 3. After completion of the test, the equipment shall be tested for its nominal operation as per document Ref: Type Test Format for KAVACH Hardware of M/S Firm's Name.	Procedure 2: Salt Duration: 2hrs, Mist: Duration=7 days 35± 3°C, RH: 93% (+2, -3%) No. of cycles: 04	IS: 9000 Pt. XI	Set	1
10	Environmental Reliability Test	Dust test	Non Operating	✓	✓	✓	RFID Reader, Radio Antenna, GPS & GSM Antenna, Radio Modem, DMI, SMOCIP,BIU,RFID Tag	1. The system shall be switched off during the test. 2. No apparent damage or deterioration should be observed. 3. After completion of the test, the equipment shall be tested for its nominal operation as per document Ref: Type Test Format for KAVACH Hardware of M/S Firm's Name.	1 hour only	IS: 9000 Pt.XII	Set	1
11a	Environmental Reliability Test	Water Immersion Test	Non Operating	X	X	X	RFID Tag	After this test,electrical parameters shall be monitored in addition to physical checks(Ingress of water).	Head of water 0.4 m Duration 24 hours Condition After this test, electrical parameters shall be monitored in addition to physical checks (Ingress of water).	RDSO/SPN/144/2006 Rev 02 : Clause 9.3 - 8/ IS 9000 Part XV Sect. 7	Set	1
11b	Environmental Reliability Test	Driving Rain test	Non Operating	X	X	X	RFID Tag, RFID Reader, Radio Antenna, GPS & GSM Antenna, Pulse Generator	After this test, electrical parameters shall be monitored in addition to physical checks.	Water spray for 1 hour	IS 9000 Part XVI Test condition 'c'	Set	1
12	Environmental Reliability Test	Insulation Resistance (IR) Test after completion of each Climatic Clause	NA	✓	✓	✓	x	The values shall not be less than 10 Mega ohms for the equipment at a temperature of 40°C and relative humidity 60%. The measurement shall be made at a potential of 500V DC.	This test shall be conducted between the equipment power supply line terminals and the earth.	Clause no. 23.4.1 (b) of RDSO/SPN/196/2020 SRS Ver.- 4.0, Ref.- 9.5 (c) of RDSO/SPN/144/2014	Set	1
III	EMI/EMC											

KAVACH PROJECT
PACKAGE DETAILS Development of KAVACH System-Type Certification
BHEL DOCUMENT NUMBER: EN-TS-04-52-505-K-003 Annexure 1

1	EMI EMC	Variation and interruption of voltage supply	Operating	x	✓	x	RFID Tag to be present with RFID Reader	1. System shall be fully functional during test. 2. No apparent damage or deterioration should be observed during physical check, after completion of test and standard recovery. 3. After completion of the test, the equipment shall be tested for its nominal operation as per Sr. No. 9.2 of document Ref: Type Test Format for KAVACH Hardware of M/S Firm's Name.	1. Voltage fluctuations lying between 0.6 Un and 1.4 Un and not exceeding 0.1s (100msec) shall not cause deviation of function. Note : Un is Nominal voltage Onboard KAVACH: 72 VDC Nominal voltage 0.6 Un = 43.2V, 1.4 Un = 100.8 VDC (Input voltage variation from 43.2 VDC to 100.8 VDC) Onboard KAVACH: 110VDC Nominal voltage 0.6 Un = 66.0V, 1.4 Un = 154.0 VDC (Input voltage variation from 66.0 VDC to 154.0 VDC) 2. Interruption of voltage supply: system input power supply ON/OFF Interruptions up to 10ms. This shall not cause any equipment failure.	(Class: S2) to equipment tests as per clause 5.1.1.2 and 5.1.1.3 of IEC 60571 -2012 in accordance with IEC-61000-4.29 or relevant clause of latest amendment/issue.	Set	1
2	EMI EMC	Supply Overvoltage	Operating	x	✓	x	✓	1. System shall be fully functional during test. 2. No apparent damage or deterioration should be observed during physical check, after completion of test and standard recovery. 3. After completion of the test, the equipment shall be tested for its nominal operation as per Sr. No. 9.2 of document Ref: Type Test Format for KAVACH Hardware of M/S Firm's Name.	1. Supply over-voltage (as per below Table) i. Voltage level (minimum) 1.4 Un Note : Un is Nominal voltage Onboard KAVACH: 72V Nominal Voltage: 100.8V DC 110V Nominal voltage : 154.0V DC ii. Duration d(max) raise time, fall time : 0.1Sec iii. Duration D (maximum) stable state : 1.0 Sec	clauses 5.2 & 12.2.7 of IEC 60571 -2012 in accordance with IEC-61000-4.29 or relevant clause of the latest amendment/issue. Electrostatic discharge tests shall be carried out as per Clause 9.4.1 of RDSO/SPN/144/2006 or the relevant clause of the latest amendment.	Set	1
3	EMI EMC	Surge Tests	Operating	x	✓	x	✓	1. System shall be fully functional during test. 2. No apparent damage or deterioration should be observed during physical check, after completion of test and standard recovery. 3. After completion of the test, the equipment shall be tested for its nominal operation as per Sr. No. 9.2 of document Ref: Type Test Format for KAVACH Hardware of M/S Firm's Name.	Surges (as per below Table) Apply between the system voltage potential return and equipment earth terminal. Voltage level (Tolerance +/-3 %) : 1800 V Raise time (10% to 90% voltage level): 5 µs and Raise time 50% to 100%, fall time 100% to 50% : 50 µs.	clauses 5.2 & 12.2.7 of IEC 60571 -2012 in accordance with IEC-61000-4.29 or relevant clause of the latest amendment/issue. Electrostatic discharge tests shall be carried out as per Clause 9.4.1 of RDSO/SPN/144/2006 or the relevant clause of the latest amendment.	Set	1
4	EMI EMC	7 KV discharge test	Non Operating	✓	✓	✓	RFID Tag, RFID Reader,	1. The system shall be switched off during the test. 2. No apparent damage or deterioration should be observed during physical check, after completion of test and standard recovery. 3. After completion of the test, the equipment shall be tested for its nominal operation as per document Ref: Type Test Format for KAVACH Hardware of M/S Firm's Name.	1. Chassis of the equipment shall be firmly grounded. 2. A charged capacitor of 7 KV should be discharged by touching the chassis by testing probe through 330Ω resistance and 150pF capacitor. 3. The above discharge test should be repeated minimum 3 times.	RDSO/SPN/144/2006: Clause 9.4.1.	Set	1
5	EMI EMC	Transient Burst & Susceptibility Test	Operating	X	✓	X	✓		Including Electrical Fast transient and Radiated susceptibility, Conducted Susceptibility.	clause 5.5 of IEC 60571-2012 in accordance with IEC-62236-3-2 or relevant clause of latest amendment/issue	Set	1
6	EMI EMC	Radio Interference Test	Operating	X	✓	X	✓		Including conducted Emission, Radiated emission	clause 5.5 & 12.2.8 of IEC 60571-2012 in accordance with IEC-62236-3-2 or relevant clause of latest amendment/issue.	Set	1



GENERAL CONDITIONS OF CONTRACT

**SOLAR BUSINESS DIVISION
BHARAT HEAVY ELECTRICALS LIMITED**
(A Govt. of India Undertaking)
PROF. CNR RAO CIRCLE, IISc POST
MALLESHWARAM
BENGALURU - 560012



CONTENTS

Chapter-1

- 1. General Instructions to Tenderers*
 - 1.1. Dispatch Instructions*
 - 1.2. Submission of Tenders*
 - 1.3. Language*
 - 1.4. Price Discrepancy*
 - 1.5. Evaluation of Bids*
 - 1.6. Data to be enclosed*
 - 1.7. Authorisation and Attestation*
 - 1.8. Earnest Money Deposit*
 - 1.9. Security Deposit*
 - 1.10. Return of Security Deposit*
 - 1.11. Bank Guarantee*
 - 1.12. Validity of offer*
 - 1.13. Execution of Contract Agreement*
 - 1.14. Rejection of Tender and other Conditions*
 - 1.15. BHEL Fraud Prevention Policy*



2. Chapter-2

2.1. Definitions

2.2. Law Governing Contract and Court Jurisdiction

2.3. Issue of Notice

2.4. Use of land

2.5. Commencement of Work

2.6. Measurement of Work and Mode of Payment

2.7. Rights of BHEL

2.8. Responsibilities of Contractor in respect of Local Laws, Employment of Workers etc

2.9. Progress Monitoring, Monthly Review and Performance Evaluation

2.10. Time of Completion

2.11. Extension of Time for Completion

2.12. Over Run Compensation

2.13. Quantity Variation

2.14. Extra Works

2.15. Supplementary Items

2.16. Strikes & Lockout

2.17. Force Majeure

2.18. Arbitration and Reconciliation

2.19. Payments

2.20. Performance Guarantee for Workmanship

2.21. Closing of Contracts

2.22. Reverse Auction

2.23. Suspension of Business Dealings

2.24. Other Issues

CHAPTER -1

1. GENERAL INSTRUCTION TO TENDERERS

1.1. DESPATCH INSTRUCTION

i) The General Conditions of Contract form part of the Tender specifications. All pages of the tender documents shall be duly signed, stamped and submitted along with the offer in token of complete acceptance thereof. The information furnished shall be complete by itself. The tenderer is required to furnish all the details and other documents as required in the following pages

ii) Tenderers are advised to study all the tender documents carefully. Any submission of tender by the tenderer shall be deemed to have been done after careful study and examination of the tender documents and with the full understanding of the implications thereof. Should the tenderers have any doubt about the meaning of any portion of the Tender Specification or find discrepancies or omissions in the drawings or the tender documents issued are incomplete or shall require clarification on any aspects, the scope of work etc., he shall contact the authority inviting the tender well in time (so as not to affect last date of submission) for clarification before the submission of the tender. Tenderer's request for clarifications shall be with reference to Sections and Clause numbers given in the tender documents. The tender specifications and terms and conditions shall be deemed to have been accepted by the tenderer in the offer. Pre requirements and conditions shall be liable for rejection.

iii) Integrity pact (IP): If NIT calls for Integrity Pact, the same shall be duly signed & stamped by the authorised signatory & submitted along with tender document.

1.2. SUBMISSION OF TENDERS

1.2.1 The tenderers must submit their tenders as per instructions in the NIT

1.2.2 BHEL takes no responsibility for delay, loss or non-receipt of tenders sent by post/courier. The tenders received after the specified time of their submission are treated as 'Late Tenders' and shall not be considered under any circumstances. Offers received by Fax/Email/Internet shall be considered as per terms of NIT.

1.2.3 Tenders shall be opened by authorised Officer of BHEL at his office at the time and date as specified in the NIT, in the presence of such of those tenderers or their authorised representatives who may be present



1.2.4 Tenderers whose bids are found techno commercially qualified shall be informed the date and time of opening of the Price Bids and such Tenderers may depute their representatives to witness the opening of the price bids. BHEL's decision in this regard shall be final and binding.

1.2.5 Before submission of Offer, the tenderers are advised to inspect the site of work and the environments and be well acquainted with the actual working and other prevalent conditions, facilities available, position of material and labour, means of transport and access to Site, accommodation, etc. No claim will be entertained later on the grounds of lack of knowledge of any of these conditions.

1.3. **LANGUAGE**

1.3.1 The tenderer shall quote the rates in English language and international numerals. These rates shall be entered in figures as well as in words. For the purpose of the tenders, the metric system of units shall be used.

1.3.2 All entries in the tender shall either be typed or written legibly in ink. Erasing and overwriting is not permitted and may render such tenders liable for rejection. All cancellations and insertions shall be duly attested by the tenderer.

1.4 **PRICE DISCREPANCY:**

1.4.1 Conventional (Manual) Price Bid opening:

i) If, in the price structure quoted for the required goods/services/works, there is discrepancy between the unit price and the total price (which is obtained by multiplying the unit price by the quantity), the unit price shall prevail and the total price corrected accordingly, unless in the opinion of BHEL there is obvious misplacement of decimal point in the unit price, in which case the total price as quoted shall govern and the unit price corrected accordingly

ii) If there is an error in a total corresponding to the addition or subtraction of subtotals, the subtotals shall prevail and the total shall be corrected;

iii) If there is a discrepancy between words and figures, the amount in words shall prevail, unless the amount expressed in words is related to an arithmetic error, in which case the amount in figures shall prevail subject of (i) and (ii) above.

iv) If there is such discrepancy in an offer, the same shall be conveyed to the bidder with target date up to which the bidder has to send his acceptance on the above lines and if the bidder does not agree to the decision of BHEL, the bid is liable to be ignored.

v) In case of lump sum price, if there is any difference between the amount in figures and in words, the amount quoted by the bidder in words shall be taken as correct.



vi) *In case of omission in quoting any rate for one or more items, the evaluation shall be done considering the highest quoted rate obtained against the respective items by other tenderers for the subject tender. If the tenderer becomes L-1, the notional rates for the omission items shall be the lowest rates quoted for the respective items by the other tenderers against the respective omission items for the subject job and the 'Total quoted price (loaded for omissions)' shall be arrived at. However, the overall price remaining the same as quoted originally, the rates for all the items in the 'Total quoted price (loaded for omissions)' shall be reduced item wise in proportion to the ratio of 'Original' total price and the 'Total quoted price (loaded for omissions)'.*

1.4.2 Reverse Auction: In case of Reverse Auction, the successful bidder shall undertake to execute the work as per overall price offered by him during the Reverse Auction process. In case of omission of rates, the procedure shall be as per 'Guidelines for Reverse Auction' enclosed.

i) Offers from tenderers who are under suspension (banned) by any Unit/Region/Division of BHEL shall not be considered. ii) Offers from tenderers who do not comply with the latest guidelines of Ministry/ Commissions of Govt of India shall not be considered.

1.5. EVALUATION OF BIDS

i) Technical Bids submitted by the tenderer will be opened first and evaluated for fulfilling the Pre-Qualification criteria and other conditions in NIT/Tender documents, based on documentary evidences submitted along with the offer, BHEL reserves the right to ask for proofs/documents, clarification in relation to Technical/commercial data during tender evaluation

ii) Price Bids of shortlisted bidders shall only be opened either through the conventional price bid opening or through electronic Reverse Auction, at the discretion of BHEL

iii) Price Bids of unqualified bidders shall not be opened. Reasons for rejection shall be intimated to the vendor before the opening of Price bid.

1.6. DATA TO BE ENCLOSED

The following information in full shall be furnished by the tenderer. Non-submission of this information may lead to rejection of the offer.

i) INCOME TAX PERMANENT ACCOUNT NUMBER, GSTIN, SAC, HSN Certified copies of PAN, GSTIN shall be furnished along with tender. The names, addresses and contact information of the Directors/Partners shall be furnished along with the offer.

ii) An attested copy of the Power of Attorney, in case the tender is signed by an individual other than the sole proprietor.



iii) *IN CASE OF INDIVIDUAL TENDERER:*

His / her full name, address, PAN, GSTIN and place & nature of business to be furnished. iv)

IN CASE OF PARTNERSHIP FIRM

The names of all the partners and their addresses, a copy of the partnership deed/instrument of partnership shall be enclosed.

v) *IN CASE OF COMPANIES:*

Date and place of registration including date of commencement certificate in case of Public Companies (certified copies of Memorandum and articles of Association are also to be furnished). Nature of business carried on by the Company and the provisions of the Memorandum relating thereof.

1.7. AUTHORIZATION AND ATTESTATION

Tenders shall be signed by a person duly authorised/empowered to do so. An attested copy of the Power of Attorney, in case the tender is signed by an individual other than the sole proprietor shall be submitted along with the tenders

1.8. EARNEST MONEY DEPOSIT

1.8.1 Every tender must be accompanied by the prescribed amount of Earnest Money Deposit (EMD) in the manner described herein.

The EMD may be accepted only in the following forms:

- (i) Electronic Fund Transfer credited in BHEL account (before tender opening)*
- (ii) Banker's cheque/ Pay order/ Demand draft, in favour of BHEL (along with offer) In case total EMD amount is more than Rs.20 Lakh, the amount in excess of Rs.20 lakh maybe accepted in the form of Bank Guarantee from scheduled bank. The Bank Guarantee in such cases shall be valid for at-least six months.*
- (iii) Through SBI collect/RTGS (before tender opening)*
- (iv) No other form of EMD remittance shall be acceptable to BHEL*

1.8.2 EMD by the bidder will be forfeited as per Tender Documents if

- i) After opening the tender and within the offer validity period, the tenderer revokes his/her tender or makes any modification in his tender which is not acceptable to BHEL.*
- ii) The Contractor fails to deposit the required Security deposit or commence the work within the period as per LOI/ Contract.*
- iii) EMD by the tenderer shall be withheld in case any action on the tenderer is envisaged in derailing the tender process by unlawful means.*

1.8.3 EMD shall not carry any interest.



1.8.4 In the case of unsuccessful bidders, the Earnest Money will be refunded to them within a reasonable time after acceptance of award by successful tenderer.

1.8.5 EMD of successful tenderer will be converted as part of Security Deposit

1.9. **SECURITY DEPOSIT**

"Bidder agrees to submit performance security required for execution of the contract within the time period mentioned. In case of delay in submission of performance security, enhanced performance security which would include interest (SB/ rate + 6%) for the delayed period, shall be submitted by the bidder. Further, if performance security is not submitted till such time the first bill becomes due, the amount of performance security due shall be recovered as per terms defined in NIT I contract, from the bills along with due interest "

The total amount of Security Deposit will be 5% of the contract value (including all applicable taxes) EMD of the successful tenderer shall be converted and adjusted towards the required amount of Security Deposit.

1.9.1 Modes of Security deposit:

The balance amount to make up the required Security Deposit of 5% of the contract value may be accepted in the following forms:

i) Cash (as permissible under the extant Income Tax Act) ii) Local cheques of Scheduled Banks (subject to realization)/ Pay Order/ Demand Draft/ Electronic Fund Transfer in favour of BHEL

iii) Bank Guarantee from Scheduled Banks/ Public Financial Institutions as defined in the Companies Act. The Bank Guarantee format should have the approval of BHEL iv) Fixed Deposit Receipt issued by Scheduled Banks/ Public Financial Institutions as defined in the Companies Act (FDR should be in the name of the Contractor, a/c BHEL)

v) Securities available from Indian Post offices such as National Savings Certificates, Kisan Vikas Patras etc. (held in the name of Contractor furnishing the security and duly endorsed/ hypothecated/ pledged, as applicable, in favour of BHEL) (Note: BHEL will not be liable or responsible in any manner for the collection of interest or renewal of the documents or in any other matter connected therewith) vi) 50% of the required Security Deposit, including the EMD, should be paid before start of the work. Balance of the Security Deposit can be collected by deducting 10% of the gross amount progressively from each of the running bills of the Contractor till the total amount of the required Security Deposit is collected. If the value of work done at any time exceeds the contract value, the amount of Security Deposit shall be correspondingly enhanced and the additional Security Deposit shall be immediately deposited by the Contractor or recovered from payment/s due to the Contractor. Security Deposit shall be released to the Contractor upon fulfilment of contractual obligations as per terms of the contract.

1.9.2 The Security Deposit shall not carry any interest.



1.9.3 The validity of Bank Guarantees towards Security Deposit shall be initially up to the completion period as stipulated in the Letter of Intent/Award (plus maintenance period if applicable), and 03 months claim period. The same shall be kept valid by proper renewal till the acceptance of Final Bills of the Contractor, by BHEL

1.9.4 BHEL reserves the right of forfeiture of Security Deposit in addition to other claims and penalties in the event of the Contractor's failure to fulfil any of the contractual obligations or in the event of termination of contract as per terms and conditions of contract. BHEL reserves the right to set off the Security Deposit against any claims of other contracts with BHEL.

1.10. **REFUND OF SECURITY DEPOSIT**

50% of the security deposit may be refunded on completion of the work after payment of the final bill and the balance 50% of the security deposit is refunded only after the expiry of the maintenance period from date of completion of work as stipulated in the contract concerned.

1.10.1 DEFECTS LIABILITY PERIOD:

The contractor shall be responsible to make good and remedy at his own expenses within such period as may be stipulated by the Engineer-in-charge, any defect which may develop or may be noticed before the expiry of the maintenance period of six months or as stipulated in NIT hereto from the certified date of completion and intimation of which has been sent to the contractor within seven days of the expiry of the said period by a letter sent by hand delivery or by registered post or Email. If contractor fails to attend to the above, defect will be rectified at contractor's risk & cost and same will be deducted from the security deposit/payable amounts available with BHEL.

1.11. **BANK GUARANTEES**

Where ever Bank Guarantees are to be furnished/submitted by the contractor, the following shall be complied with

i) Bank Guarantees shall be from Scheduled Banks / Public Financial Institutions as defined in the Companies Act. ii) The Bank Guarantees shall be as per prescribed BHEL formats.

iii) It is the responsibility of the bidder to get the Bank Guarantees revalidated/extended for the required period (subject to a minimum period of six months), as per the advice of BHEL. BHEL shall not be liable for issue of any reminders regarding expiry of the Bank Guarantees.

iv) In case extension/further extensions of any Bank Guarantees are not required, the bidders shall ensure that the same is explicitly endorsed by BHEL



- v) *In case the Bank Guarantees are not extended before the expiry date, BHEL reserves the right to invoke the same by informing the concerned Bank in writing, without any advance notice/communication to the concerned bidder.*
- vi) *Bidders to note that any corrections to Bank Guarantees shall be done by the issuing Bank, only through an amendment in an appropriate non judicial stamp paper.*
- vii) *The Original Bank Guarantee shall be sent directly by the Bank to BHEL under Registered Post (Acknowledgement Due).*

1.12. VALIDITY OF OFFER

The rates in the Tender shall be kept open for acceptance for a minimum period of Ninety (90) DAYS from latest due date of offer submission (including extension, if any). In case BHEL calls for negotiations, such negotiations shall not amount to cancellation or withdrawal of the original offer which shall be binding on the tenderers.

1.13 EXECUTION OF CONTRACT AGREEMENT

The successful tenderer's responsibility under this contract commences from the date of issue of the Letter of Intent by BHEL. The Tenderer shall submit an unqualified acceptance to the Letter of Intent/Award within the period stipulated therein.

The successful tenderer shall be required to execute an agreement in the prescribed form, with BHEL, within fifteen days (15 days) after the acceptance of the Letter of Intent/Award, and in any case before releasing the first running bill. The contract agreement shall be signed by a person duly authorized/empowered by the tenderer. The expenses for preparation of agreement document shall be borne by Tenderer.

1.14. REJECTION OF TENDER AND OTHER CONDITIONS

1.14.1 The acceptance of tender will rest with BHEL which does not bind itself to accept the lowest tender or any tender and reserves to itself full rights for the following without assigning any reasons whatsoever: -

- a. To reject any or all of the tenders.*
- b. To split up the work amongst two or more tenderers as per NIT*
- c. To award the work in part if specified in NIT*
- d. In case of either of the contingencies stated in (b) and (c) above, the time for completion as stipulated in the tender shall be applicable.*



1.14.2 Conditional tenders, unsolicited tenders, tenders which are incomplete or not in the form specified or defective or have been materially altered or not in accordance with the tender conditions, specifications etc., are liable to be rejected.

1.14.3 Tenders are liable to be rejected in case of unsatisfactory performance of the tenderer with BHEL, or tenderer under suspension (hold/banning /delisted) by any unit / region / division of BHEL or tenderers who do not comply with the latest guidelines of Ministry/Commissions of Govt of India. BHEL reserves the right to reject a bidder in case it is observed that they are overloaded and may not be in a position to execute this job. The decision of BHEL will be final in this regard.

1.14.4 If a tenderer who is a proprietor expires after the submission of his tender or after the acceptance of his tender, BHEL may at their discretion, cancel such tender. If a partner of a firm expires after the submission of tender or after the acceptance of the tender, BHEL may then cancel such tender at their discretion, unless the firm retains its character.

1.14.5 BHEL will not be bound by any Power of Attorney granted by changes in the composition of the firm made subsequent to the execution of the contract. They may, however, recognize such power of Attorney and changes after obtaining proper legal advice, the cost of which will be chargeable to the contractor concerned.

1.14.6 If the tenderer deliberately gives wrong information in his tender, BHEL reserves the right to reject such tender at any stage or to cancel the contract if awarded and forfeit the Earnest Money/Security Deposit/any other money due.

1.14.7 Canvassing in any form in connection with the tenders submitted by the Tenderer shall make his offer liable to rejection.

1.14.8 In case the Proprietor, Partner or Director of the Company/Firm submitting the Tender, has any relative or relation employed in BHEL, the authority inviting the Tender shall be informed, along with the Offer. Failing to do so, BHEL may, at its sole discretion, reject the tender or cancel the contract and forfeit the Earnest Money/Security Deposit.

1.14.9 The successful tenderer should not sub-contract part or complete work detailed in the tender specification undertaken by him without written permission of BHEL's Construction Manager/Site Incharge. The tenderer is solely responsible to BHEL for the work awarded to him.

1.14.10 The Tender submitted by a techno commercially qualified tenderer shall become the property of BHEL who shall be under no obligation to return the same to the bidder. However unopened price bids and late tenders shall be returned to the bidders after finalization of contract.

1.14.11 Unsolicited discount received after the due date and time of Bid Submission shall not be considered for evaluation. However, if the party who has submitted the unsolicited



discount/rebate becomes the L-I party, then the awarded price i.e contract value shall be worked out after considering the discount so offered.

1.14.12 BHEL shall not be liable for any expenses incurred by the bidder in the preparation of the tender irrespective of whether the tender is accepted or not.

1.15 BHEL Fraud Prevention Policy:

The bidder along with its associate/ collaborators/sub-contractors/ Sub-Vendors/ Consultants/service providers shall strictly adhere to BHEL Fraud Prevention Policy displayed on BHEL website <http://www.bhel.com> and shall immediately bring to the notice of BHEL Management about any fraud or suspected fraud as soon as it comes to their notice. Fraud prevention policy and list of Nodal officers shall be hosted on BHEL website, vendor portals of Units/Regions Internet.

CHAPTER-2

2.1 DEFINITION: The following terms shall have the meaning hereby assigned to them except where the context otherwise requires

- i) BHEL shall mean Bharat Heavy Electricals Limited, a company registered under Companies Act 1956, with its Registered Office at BHEL HOUSE, SIRI FORT, NEW DELHI – 110 049, or its Authorised Officers or its Site Engineers or other employees authorised to deal with any matters with which these persons are concerned on its behalf.
- ii) “EXECUTIVE DIRECTOR” or ‘GROUP GENERAL MANAGER’ or “GENERAL MANAGER (Incharge)” or “GENERAL MANAGER” shall mean the Officer in SOLAR BUSINESS DIVISION, Prof. CNR Rao Circle, IISc Post, Malleshwaram, BENGALURU - 560012
- iii) “COMPETENT AUTHORITY” shall mean Executive Director or Group General Manager or General Manager (In-charge) or General Manager or BHEL Officers who are empowered to act on behalf of the Executive Director or General Manager (In-charge) or General Manager of BHEL.
- iv) “ENGINEER” or “ENGINEER IN CHARGE” shall mean an Officer of BHEL as may be duly appointed and authorized by BHEL to act as “Engineer” on his behalf for the purpose of the Contract, to perform the duty set forth in this General Conditions of Contract and other Contract documents. The term also includes ‘CONSTRUCTION MANAGER’ or ‘SITE INCHARGE’ as well as Officers



- v) *"SITE" shall mean the places or place at which the plants/equipment are to be erected and services are to be performed as per the specification of this Tender.*
- vi) *"CLIENT OF BHEL" or "CUSTOMER" shall mean the project authorities with whom BHEL has entered into a contract for supply of equipment or provision of services.*
- vii) *"CONTRACTOR" shall mean the successful Bidder/Tenderer who is awarded the Contract and shall include the Contractor's successors, heirs, executors, administrators and permitted assigns.*
- viii) *"CONTRACT" or "CONTRACT DOCUMENT" shall mean and include the Work Order, Contract Agreement, the accepted appendices of Rates, Schedules, Quantities if any, General Conditions of Contract, Special Conditions of Contract, Instructions to the Tenderers, Drawings, Technical Specifications, the Special Specifications if any, the Tender documents, subsequent amendments mutually agreed upon and the Letter of Intent/Acceptance issued by BHEL. Any conditions or terms stipulated by the contractor in the tender documents or subsequent letters shall not form part of the contract unless, specifically accepted in writing by BHEL in the Letter of Intent/Award and incorporated in the agreement.*
- ix) *"GENERAL CONDITIONS OF CONTRACT" shall mean the 'Instructions to Tenderers' and 'General Conditions of Contract' pertaining to the work for which above tenders have been called for.*
- x) *"TENDER SPECIFICATION" or "TENDER" or "TENDER DOCUMENTS" shall mean General Conditions, Common Conditions, Special Conditions, Price Bid, Rate Schedule, Technical Specifications, Appendices, Annexures, Corrigendum's, Amendments, Forms, procedures, Site information, etc and drawings/documents pertaining to the work for which the tenderers are required to submit their offers. Individual specification number will be assigned to each Tender Specification.*
- xi) *"LETTER OF INTENT" shall mean the intimation by a Post/Fax/email to the tenderer that the tender has been accepted in accordance with provisions contained in the letter. The responsibility of the contractor commences from the date of issue of this letter and all terms and conditions of the contract are applicable from this date.*
- xii) *"COMPLETION TIME" shall mean the period by 'date/month' specified in the 'Letter of Intent/Award' or date mutually agreed upon for handing over of the intended scope of work, the erected equipment/plant which are found acceptable by the Engineer, being of required standard and conforming to the specifications of the Contract.*
- xiii) *"PLANT" shall mean and connote the entire assembly of the plant and equipment's covered by the contract.*



- xiv) *"EQUIPMENT"* shall mean equipment, machineries, materials, structural, electrical and other components of the plant covered by the contract.
- xv) *"TESTS"* shall mean and include such test or tests to be carried out on the part of the contractor as are prescribed in the contract or considered necessary by BHEL, in order to ascertain the quality, workmanship, performance and efficiency of the contractor or part thereof.
- xvi) *"APPROVED", "DIRECTED" or "INSTRUCTED"* shall mean approved, directed or instructed by BHEL.
- xvii) *"WORK or CONTRACT WORK"* shall mean and include supply of all categories of labour, specified consumables, tools and tackles and Plants required for complete and satisfactory site transportation, handling, stacking, storing, erecting, testing and commissioning of the equipment's to the entire satisfaction of BHEL.
- xviii) *"SINGULAR AND PLURALS ETC"* words carrying singular number shall also include plural and vice versa, where the context so requires. Words imparting the masculine Gender shall be taken to include the feminine Gender and words imparting persons shall include any Company or Associations or Body of Individuals, whether incorporated or not.
- xix) *"HEADING"* – The heading in these General Conditions are solely for the purpose of facilitating reference and shall not be deemed to be part thereof or be taken as instructions thereof or of the contract.
- xx) *"MONTH"* shall mean calendar month unless otherwise specified in the Tender.
- xxi) *Day' or 'Days'* unless herein otherwise expressly defined shall mean calendar day or days of twenty-four (24) hours each. A week shall mean continuous period of seven (7) days.
- xxii) *"COMMISSIONING"* shall mean the synchronization testing and achieving functional operation of the Equipment with associated system after all initial adjustments, trials, cleaning, re-assembly required at site if any, have been completed and Equipment with associated system is ready for taking into service.
- xxiii) *"WRITING"* shall include any manuscript type written or hand written or printed statement or electronically transmitted messages, under the signature or seal or transmittal of BHEL.
- xxiv) *"TEMPORARY WORK"* shall mean all temporary works for every kind required in or for the execution, completion, maintenance of the work.
- xxv) *'CONTRACT PRICE' or 'CONTRACT VALUE'* shall mean the sum including applicable taxes mentioned in the LOI/LOA/Contract Agreement subject to such additions thereto or deductions there from as may be made under provisions hereinafter contained



xxvi) "COMMENCEMENT DATE" or "START DATE" shall mean the commencement/start of work at Site as per terms defined in the Tender

xxvii) "SHORT CLOSING" or "FORE CLOSING" of Contract shall mean the premature closing of Contract, for reasons not attributable to the contractor and mutually agreed between BHEL and the contractor

xxviii) "TERMINATION" of Contract shall mean the premature closing of contract due to reasons as mentioned in the contract

2.2 LAW GOVERNING THE CONTRACT AND COURT JURISDICTION

The contract shall be governed by the Law for the time being in force in the Republic of India. The Civil Court having original Civil Jurisdiction at Bengaluru, shall alone have exclusive jurisdiction in regard to all claims in respect of the Contract. No other Civil Court shall have jurisdiction in case of any dispute, under this contract

2.3 ISSUE OF NOTICE

2.3.1 Service of notice on contractor: Any notice to be given to the Contractor under the terms of the contract shall be served by sending the same by Registered Post / Speed Post/ FAX / Email to or leaving the same at the Contractor's last known address of the principal place of business (or in the event of the contractor being a company, to or at its Registered Office). In case of change of address, the notice shall be served at changed address as notified in writing by the Contractor to BHEL. Such posting or leaving of the notice shall be deemed to be good service of such notice and the time mentioned to the condition for doing any act after notice shall be reckoned from the date so mentioned in such notice.

2.3.2 Service of notice on BHEL Any notice to be given to BHEL in-charge under the terms of the Contract shall be served by sending the same by post or Email or leaving the same at BHEL address or changed address as notified in writing by BHEL to the Contractor.

2.4 USE OF LAND

No land belonging to BHEL or their Customer under temporary possession of BHEL shall be occupied by the contractor without written permission of BHEL.

2.4.1 STORES AND MATERIALS:

The contractor shall, at his own expense, supply all stores and materials required for the contract, other than those which may be provided by BHEL at the rates detailed therein subject to their availability at the place of issue indicated therein. All stores and materials to be supplied by the Contractor shall be of the best kind as described in the Specifications and the Contractor shall, if required by the Engineer –in- charge furnish him with proof to his satisfaction that the store and materials so comply with the specifications.



The contractor shall, at his own expense and without delay, supply samples of stores and materials proposed to be used in the execution of the work for the approval of the Engineer-in charge, who may reject all stores and materials not corresponding either in quality or character to the approved samples.

In the case of stores provided by BHEL, the Contractor shall bear the cost of loading, transporting to site, unloading, storing under cover as required, assembling & jointing the several parts together as necessary and incorporating & fixing these stores & materials in the work, including all preparatory work of whatever description that may be required, and closing, preparing, loading and returning empty cases or containers to the place of issue without any extra charges.

Contractor is responsible for safe & secure storage of above material.

2.4.2 PATENT RIGHTS:

The contractor shall fully indemnify BHEL, or the agent, servant, or employee of BHEL, against any action, claim or proceeding relating to infringement or the use of any patent or design or any alleged patent or design rights, and shall pay any royalties which may be payable in respect of any article/ or part thereof included in the contract.

In the event of any claims being made or action brought against BHEL, or any agent, or servant or employee of BHEL., in respect of any of the matters aforesaid, the contractor shall not apply when such increment has taken place in complying with the specific directions issued by the BHEL but the contractor shall pay any royalties payable in respect of any such use.

2.4.3 WATER:

The contractor shall allow in his tender and provide at his cost all water required for the work or his employees on the work, together with all pipes and fittings or other means that may be necessary or required to ensure a proper and ample supply of water for all purpose connected with the work.

In the event of a provision existing in the Tender documents for supply of water on payment by BHEL, water will be supplied from the BHEL supply System, or other sources at any points fixed by the Site Engineer/ Engineer-in-charge on the site of work. The contractor shall make necessary arrangement for lifting, pumping, carrying or conveying the water as required at his own cost. The levy of water charges to be borne by the Contractor in such case shall be specifically mentioned in the Tender documents.

2.4.4 TEMPORARY WORKSHOPS, STORES ETC.:

The Contractor shall, during the progress of the work provide, erect and maintain at his own expense all necessary temporary workshops, store, offices, toilets etc., required for the proper and efficient execution of the work. The planning, siting and erection of these building shall have the approval of the Engineer-in-charge and the Contractor shall at all times keep them in a clean and sanitized condition to the entire satisfaction of the Engineer-in-charge.

On completion of the work all such temporary buildings shall be cleared and the site restored to its original state in a clean and tidy condition to the entire satisfaction of the Engineer-in-charge.

2.5 COMMENCEMENT OF WORK

2.5.1 Time is essence of contract and is specified in the tender document or in each individual work order.

2.5.2 The contractor shall commence the work within seven (07) days from LOI/work order or as intimated by BHEL and shall proceed with the same with due expedition without delay.

2.5.3 If the contractor fails to start the work within stipulated time as per LOI or as intimated by BHEL, then BHEL at its sole discretion will have the right to cancel the contract. The Earnest Money and/or Security Deposit with BHEL will stand forfeited without any further reference to him without prejudice to any and all of BHEL's other rights and remedies in this regard.

2.5.4 All the work shall be carried out under the direction and to the satisfaction of BHEL.

2.6 MEASUREMENT OF WORK AND MODE OF PAYMENT:

2.6.1 All payments due to the contractors shall be made by electronic mode only, unless otherwise found operationally difficult.

2.6.2 For progress running bill payments: - The Contractor shall present detailed measurement sheets in triplicate, duly indicating all relevant details based on technical documents and connected drawings for work done during the month/period under various categories in line with terms of payment as per contract. The basis of arriving at the quantities, weights shall be relevant documents and drawings released by BHEL. These measurement sheets shall be prepared jointly with BHEL Engineers and signed by both the parties.

2.6.3 These measurement sheets will be checked by BHEL Engineer and quantities and percentage eligible for payment under various groups shall be decided by BHEL Engineer.



The abstract of quantities and percentage so arrived at based on the terms of payment shall be entered in Measurement Book and signed by both the parties.

2.6.4 Based on the above quantities, contractor shall prepare the bills in prescribed format and work out the financial value. These will be entered in Measurement Book and signed by both the parties. Payment shall be made by BHEL after effecting the recoveries due from the contractor.

2.6.5 All recoveries due from the contractor for the month/period shall be effected in full from the corresponding running bills unless specific approval from the competent authorities is obtained to the contrary.

2.6.6 Measurement shall be restricted to that portion of work for which it is required to ascertain the financial liability of BHEL under this contract.

2.6.7 The measurement shall be taken jointly by persons duly authorized on the part of BHEL and by the Contractor.

2.6.8 The Contractor shall bear the expenditure involved if any, in making the measurements and testing of materials to be used/used in the work. The contractor shall, without extra charges, provide all the assistance with appliances and other things necessary for measurement.

2.6.9 If at any time due to any reason whatsoever, it becomes necessary to re-measure the work done in full or in part, the expenses towards such re measurements shall be borne by the contractor unless such re measurements are warranted solely for reasons not attributable to contractor.

2.6.10 Passing of bills covered by such measurements does not amount to acceptance of the completion of the work measured. Any left out work has to be completed, if pointed out at a later date by BHEL.

2.6.11 Final measurement bill shall be prepared in the final bill format prescribed for the purpose based on the certificate issued by BHEL Engineer that entire works as stipulated in tender specification has been completed in all respects to the entire satisfaction of BHEL. Contractor shall give unqualified "No Claim" Certificate. All the tools and tackles loaned to him should be returned in satisfactory condition to BHEL. The abstract of final quantities and financial values shall also be entered in the Measurement Books and signed by both parties to the contract. The Final Bill shall be prepared and paid within a reasonable time after completion of work.



2.7 RIGHTS OF BHEL

BHEL reserves the following rights in respect of this contract during the original contract period or its extensions if any, as per the provisions of the contract, without entitling the contractor for any compensation.

2.7.1 To withdraw any portion of work and/or to restrict/alter quantum of work as indicated in the contract during the progress of work and get it done through other agencies to suit BHEL's commitment to its customer or in case BHEL decides to advance the date of completion due to other emergent reasons/ BHEL's obligation to its customer.

2.7.2 To terminate the contract or get any part of the work done through other agency or deploy BHEL's own/hired/otherwise arranged resources, at the risk and cost of the contractor after due notice of a period of two weeks by BHEL, in the event of: -

i) Contractor's continued poor progress

ii) Withdrawal from or abandonment of the work before completion of the work iii)

Contractor's inability to progress the work for completion as stipulated in the contract

iv) Poor quality of work

v) Corrupt act of Contractor

vi) Insolvency of the Contractor

vii) Persistent disregard to the instructions of BHEL

viii) Assignment, transfer, sub-letting of contract without BHEL's written permission

ix) Non fulfilment of any contractual obligations / non-compliance of statutory requirements

x) In the opinion of BHEL, the contractor is overloaded and is not in a position to execute

the job as per required schedule

2.7.3 To meet the expenses including BHEL overheads of 35% & Liquidated damage/penalties arising out of "Risk & Cost" as explained above under SI.No. 2.7.2. BHEL shall recover the amount from any money due from Contractor, from any money due to the Contractor including Security Deposit or by forfeiting any T&P or material of the contractor under this contract or any other contract of BHEL or by any other means or any combination thereof

2.7.4 To terminate the contract or to restrict the quantum of work and pay for the portion of work executed in case BHEL's contract with their customer are terminated for any reason, as per mutual agreement.



2.7.5 To effect recovery from any amounts due to the contractor under this or any other contract or in any other form, the moneys BHEL is statutorily forced to pay to anybody, due to contractor's failure to fulfil any of his obligations. BHEL shall levy overheads of 35% on all such payments.

2.7.6 While every endeavour will be made by BHEL to this end, they cannot guarantee uninterrupted work due to conditions beyond their control. The Contractor will not be normally entitled for any compensation/extra payment on this account unless otherwise specified elsewhere in the contract.

2.7.7 In case the execution of works comes to a complete halt or reaches a stage wherein worthwhile works cannot be executed and there is no possibility of commencement of work for a period of not less than two months, due to reasons not attributable to the contractor and other than Force Majeure conditions, BHEL may consider permitting the contractor to de mobilize forthwith and re mobilize at an agreed future date. Cost of such demobilization/remobilization shall be mutually agreed. ORC (Over run Charges) in such cases shall not be applicable for the period between the period of demobilization and re mobilisation. The duration of contract/time extension shall accordingly get modified suitably. In case of any conflict, BHEL decision in this regard shall be final and binding on the contractor.

2.7.8 In the unforeseen event of inordinate delay in receipt of materials, drawings, fronts, etc, due to which inordinate discontinuity of work is anticipated, BHEL at its discretion may consider contractor's request to short close the contract, provided that the balance works are minor vis a vis the scope of work envisaged as per the contract. At the point of requesting for short closure, contractor shall establish that he has completed all works possible of completion and he is not able to proceed with the balance works due to constraints beyond his control. In such a case, the estimated value of the unexecuted portion of work as mutually agreed, shall however be reduced from the final contract value.

2.7.9 LIQUIDATED DAMAGES/PENALTY

COMPENSATION FOR DELAY:

If the contractor fails to maintain the required progress in terms of condition 2.10 or to complete the work and clear the site on or before the contracted or extended the period of completion, he shall, without prejudice to any other right or remedy of the BHEL on account of such breach, pay as agreed compensation an amount calculated as stipulated below

For unfinished anticipated value of work where finished portion is fit for use

Rate of compensation as follows:



- Completion period (as originally stipulated) not exceeding 6 months.@ 1 percent per week
- Completion period (as originally stipulated) Exceeding 6 months and not exceeding 2 years...@ 0.5 percent per week
- Completion period (as originally stipulated) exceeding 2 years..... @ 0.25 percent per week

Provided always that the total amount of compensation for delay to be paid under condition shall not exceed the under noted percentage of the anticipated contract value

- Completion period (as originally stipulated) not exceeding 6 months.@ 10 percent of anticipated value of work
- Completion period (as originally stipulated) Exceeding 6 months and not exceeding 2 years...@ 7.5 percent of anticipated value of work
- Completion period (as originally stipulated) Exceeding 2 years.....@ 5 percent of anticipated value of work

The amount of compensation may be adjusted or set off against any sum payable to the Contractor under this or any other contract with the BHEL.

2.7.10 POST TECHNICAL AUDIT OF WORK AND BILLS: BHEL reserve the right to carry out a post-payment audit and technical examination of the work and final bill including all supporting vouchers, abstract etc., and to enforce recovery of any sums becoming due as a result thereof in the manner provided in the proceeding sub-paragraph's provided however that no such recovery shall be enforced after three years of passing the final bill

2.8 RESPONSIBILITIES OF THE CONTRACTOR IN RESPECT OF LOCAL LAWS, EMPLOYMENT OF WORKERS ETC.

The following are the responsibilities of the contractor in respect of observance of local laws, employment of personnel, payment of taxes etc. The subcontractor shall fully indemnify BHEL against any claims of whatsoever nature arising due to the failure of the contractor in discharging any of his responsibilities hereunder:

2.8.1 *The contractor at all times during the continuance of this contract shall, in all his dealings with local labour for the time being employed on or in connection with the work, have due regard to all local festivals and religious and other customs.*

2.8.2 *The contractor shall comply with all applicable State and Central Laws, Statutory Rules, Maternity act, Regulations etc. such as contract labour(R&A) Act 1970, Minimum wage Act 1974, Payment of wages Act 1936,ESI Act 1948, EPF Act 1952, Employees' compensation Act 1923, Provision of Companies Act 1948 & rules thereof, The interstate Migrant Workmen 1979, The Karnataka Factories Rules 1969, Payment of Bonus Act 1965, Payment of Gratuity Act 1972. Child labour Prohibition act 1986, Karnataka Minimum Wage Act , Prevention of sexual harassment at work place Act 2013, Guidelines/notification related to Safai Karamchari Act , Equal Remuneration Act 1976, The company's instructions as*

issued from time to time in regard to working hours, wages, leaves, holidays etc. for labour as may be enacted by the Government during the tenure of the Contract and having force or jurisdiction at Site. The Contractor shall also give to the local Governing Body, Police and other relevant Authorities all such notices as may be required by the Law.

The contractor shall produce the following registers and forms:

- Form XIII- Register of work men employed by contractor(Rule 75)
- Form XIV- Employment Card issued by contractor(Rule 76)
- Form XVI- Muster Roll (Rule 78(1) (a)(i))
- Form XVII- Register of Wages (Rule 78(1) (a)(i))
- Form XVIII- Register of wages cum Muster Roll(in case of weekly payment)
- Form XIX- Wage slip (Rule 78(b))
- Form XX- Register of deduction for damages Or Loss Rule 78(1) (a)(ii))
- Form XXI- Register of files Rule 78(1) (a)(ii))
- Form XXII- Register of Advance Rule 78(1) (a)(ii)) x Form XXIII- Register of Overtime Rule 78(1) (a)(iii))
- Form XXIV- Return to be sent by the contractor to the Licensing officer (Rule 82(1))

2.8.3 The contractor shall obtain independent License under the Contract Labour (Regulations and Abolition Act) as required from the concerned Authorities based on the certificate (Form-V) issued by the Principal Employer/Customer

2.8.4 The contractor shall pay all taxes, fees, license charges, deposits, duties, tolls, royalties, commission or other charges which may be levied on account of his operations in executing the contract.

2.8.5 While BHEL would pay the inspection fees and Registration fees of Boiler & explosive/Electrical Inspectorate, all other arrangements for site visits periodically by the Inspectorate to site, Inspection certificate etc. will have to be made by contractor. However, BHEL will not make any payment to the Inspectorate in connection with contractor's Welders/Electricians qualification tests etc.

2.8.6 Contractor shall be responsible for provision of Health and Sanitary arrangements (more particularly described in Contract Labour Regulation & Abolition Act), Safety precautions etc. as may be required for safe and satisfactory execution of contract.

2.8.7 The contractor shall be responsible for proper accommodation including adequate medical facilities for personnel employed by him.

2.8.8 The contractor shall be responsible for the proper behavior and observance of all regulations by the staff employed by him.



2.8.9 The contractor shall ensure that no damage is caused to any person/property of other parties working at site. If any such damage is caused, it is responsibility of the contractor to make good the losses or compensate for the same.

2.8.10 All the properties/equipment/components of BHEL/their Client loaned with or without deposit to the contractor in connection with the contract shall remain properties of BHEL/their Client.

2.8.11 The contractor shall use such properties for the purpose of execution of this contract. All such properties/equipment/components shall be deemed to be in good condition when received by the contractor unless he notifies within 48 hours to the contrary. The contractor shall return them in good condition as and when required by BHEL/their Client. In case of non-return, loss, damage, repairs etc, the cost thereof as may be fixed by BHEL Engineer will be recovered from the contractor

2.8.12 Any delay in completion of works/or non-achievement of periodical targets due to the reasons attributable to the contractor, the same may have to be compensated by the contractor either by increasing manpower and resources or by working extra hours and/or by working more than one shift. All these are to be carried out by the contractor at no extra cost.

2.8.13 The contractor shall arrange, coordinate his work in such a manner as to cause no hindrance to other agencies working in the same premises.

2.8.14 All safety rules and codes applied by the Client/BHEL at site shall be observed by the contractor without exception. The contractor shall be responsible for the safety of the equipment/material and works to be performed by him and shall maintain all light, fencing guards, slings etc. or other protection necessary for the purpose. Contractor shall also take such additional precautions as may be indicated from time to time by the Engineer with a view to prevent pilferage, accidents, fire hazards. Due precautions shall be taken against fire hazards and atmospheric conditions. Suitable number of Clerical staff, watch and ward, store keepers to take care of equipment/materials and construction tools and tackles shall be posted at site by the contractor till the completion of work under this contract. The contractor shall arrange for such safety devices as are necessary for such type of work and carry out the requisite site tests of handling equipment, lifting tools, tackles etc. as per prescribed standards and practices. Contractor has to ensure the implementation of Health, Safety and Environment (HSE) requirements as per directions given by BHEL/Customer. The contractor has to assist in HSE audit by BHEL/Customer and submit compliance Report. The contractor has to generate and submit record/reports as per HSE plan/activities as per instruction of BHEL/Customer. All tools, plant and equipment brought to the site shall become the property of BHEL and shall not be removed from the site without the prior written approval from BHEL. When the work is finally completed or the Contractor is determined for reasons other than the defaults of the contract, he shall forthwith remove from the site all tools, plants, equipment etc., (other than those as may have been provided by BHEL) and upon such removal, the same shall revert in, and become the property of the contractor.



2.8.15 The contractor will be directly responsible for payment of wages to his workmen on specified date of respective month declared as per applicable Labour Act. A pay roll sheet giving all the payments given to the workers and duly signed by the contractor's representative should be furnished to BHEL site for record purpose.

2.8.16 In case of any class of work for which there is no such specification as laid down in the contract, such work shall be carried out in accordance with the instructions and requirements of the Engineer.

2.8.17 Also, no idle charges will be admissible in the event of any stoppage caused in the work resulting in contractor's labour and Tools & Plants being rendered idle due to any reason at any time.

2.8.18 The contractor shall take all reasonable care to protect the materials and work till such time the plant/equipment has been taken over by BHEL or their Client whichever is earlier.

2.8.19 The contractor shall not stop the work or abandon the site for whatsoever reason of dispute, excepting force majeure conditions. All such problems/disputes shall be separately discussed and settled without affecting the progress of work. Such stoppage or abandonment shall be treated as breach of contract and dealt with accordingly

2.8.20 The contractor shall keep the area of work clean and shall remove the debris etc. while executing day-to-day work. Upon completion of work, the contractor shall remove from the vicinity of work, all scrap, packing materials, rubbish, unused and other materials and deposit them in places specified by the Engineer. The contractor will also demolish all the hutments, sheds, offices, etc. constructed and used by him and shall clean the debris. In the event of his failure to do so, the same will be arranged to be done by the Engineer and the expenses recovered from the contractor. If the work is executed in Factory premises, no hutment will be allowed.

2.8.21 The contractor shall execute the work in the most substantial and workman like manner in the stipulated time. Accuracy of work and timely execution shall be the essence of this contract. The contractor shall be responsible to ensure that the quality, assembly and workmanship conform to the dimensions and clearance given in the drawings and/ or as per the instructions of the Engineer.

2.8.22 The Contractor to note that some of BHEL's T&Ps/MMDs may not be insured. The Contractor will take necessary precautions and due care to protect the same while in his custody from any damage/ loss till the same is handed over back to BHEL. In case the damage / loss is due to carelessness/ negligence on the part of the contractor, the Contractor is liable to get them repair/ replaced immediately and in case of his failure to do so within a reasonable time, BHEL will reserve the right to recover the loss from the contractor.

2.8.23 The contractor shall provide all watchmen necessary, for the protection of the site, the work, the materials, the tools, plant, equipment and anything else lying on the site during the progress of the work. He shall solely be responsible for and shall take all reasonable and proper steps for protecting, securing, lighting and watching all places on or about the work and the site which may be dangerous to any person whom so ever.

2.8.24 SITE DRAINAGE: All water that may accumulate on the site during the process of the work, or in trenches and excavations shall be removed to the entire satisfaction of the Engineering-charge and at Contractors expense.

2.8.25 INSPECTION OF THE WORK: BHEL Officers concerned with the Contract shall have power at any time to inspect and examine any part of the work and the contractor shall give such facilities as may be required to given for such inspection and examination.

2.8.26 In case the contractor is required to undertake any work outside the scope of this contract, the rates payable shall be those mutually agreed upon if the item rates are not mentioned in existing contract

- i. For any item of wok required to be carried out after the contract has been awarded and which is not covered by Contractors Schedule but is covered by C.P.W.D. schedule of rates the rate payable for such a fresh item will be derived from updated C.P.W.D. schedule of rates by the method of proportion as follows:
- ii. Rate as per estimated updated C.P.W.D DSR and loading tender excess (plus or minus) on pro-rata basis for nearest analogous items. For other items rate as per estimated C.P.W.D DSR and loading tender excess(plus or minus) iii. If rates are not available in C.P.W.D. DSR, deviated item rates will be derived from market rate with 15% profit and overheads.

2.9 PROGRESS MONITORING, MONTHLY/ WEEKLY REVIEW AND PERFORMANCE EVALUATION

2.9.1 A detailed plan/programme for completion of the contractual scope of work as per the time schedule given in the contract shall be jointly agreed between BHEL and Contractor, before commencement of work. The above programme shall be supported by month/ week wise deployment of resources viz Manpower, T&P, Consumables, etc. Progress will be reviewed periodically (Daily/Weekly/Monthly) vis a vis this jointly agreed programme. The Contractor shall submit periodical progress reports (Daily/Weekly/Monthly) and other reports/information including manpower, consumables, T&P mobilization etc as desired by BHEL.

2.9.2 Monthly/ weekly progress review between BHEL and Contractor shall be based on the agreed programme as above, availability of inputs/fronts etc, and constraints if any, as per prescribed formats. Manpower, T&P and consumable reports as per prescribed formats shall

be submitted by contractor every month. Release of RA Bills shall be contingent upon certification by BHEL Site Engineer of the availability of the above prescribed formats duly filled in and signed.

2.9.3 The burden of proof that the causes leading to any shortfall is not due to any reasons attributable to the contractor is on the contractor himself. The monthly progress review shall record shortfalls attributable to (i) Contractor, (ii) Force Majeure Conditions, and (iii) BHEL

2.10 TIME OF COMPLETION

2.10.1 Time is essence of the contract. The time schedule shall be as prescribed in the Contract. The time for completion shall be reckoned from the date of commencement of work at Site as certified by BHEL Engineers

2.10.2 The entire work shall be completed by the contractor within the time schedule or within such extended periods of time as may be allowed by BHEL under clause 2.11

2.11 EXTENSION OF TIME FOR COMPLETION

2.11.1 If the completion of work as detailed in the scope of work gets delayed beyond the contract period, the contractor shall request for an extension of the contract and BHEL at its discretion may extend the Contract.

2.11.2 Based on the monthly reviews jointly signed, the works balance at the end of original contract period less the backlog attributable to the contractor shall be quantified, and the number of months of 'Time extension' required for completion of the same shall be jointly worked out. Within this period of 'Time extension', the contractor is bound to complete the portion of backlog attributable to the contractor. Any further 'Time extension' or 'Time extensions' at the end of the previous extension shall be worked out similarly.

2.11.3 However if any 'Time extension' is granted to the contractor to facilitate continuation of work and completion of contract, due to backlog attributable to the contractor alone, then it shall be without prejudice to the rights of BHEL to impose penalty/LD for the delays attributable to the contractor, in addition to any other actions BHEL may wish to take at the risk and cost of contractor.

2.11.4 A joint programme shall be drawn for the balance amount of work to be completed during the period of 'Time Extension', along with matching resources (with weightages) to be deployed by the contractor as per specified format. Review of the programme and record of shortfall shall be done every month of the 'Time extension' period in the same manner as is done for the regular contract period.

2.11.5 During the period of 'Time extension', contractor shall maintain their resources as per mutually agreed program

2.11.6 At the end of total work completion as certified by BHEL Engineer, and upon analysis of the total delay, the portion of time extensions attributable to (i) Contractor, (ii) Force majeure conditions, and (iii) BHEL, shall be worked out and shall be considered to be exhausted in the same order. The total period of time extensions shall be the sum of (i), (ii) and (iii) above and shall be equal to period between the scheduled date of completion and the actual date of completion of contract. LD shall be imposed/levied for the portion of time extensions attributable to contractor and recoverable from the dues payable to the contractor.

2.12 OVERRUN COMPENSATION (THIS CLAUSE IS NOT APPLICABLE IN BHEL FACTORY & TOWNSHIP PREMISES)

2.12.1 Over Run Compensation (ORC) is payable by way of rate revisions for periods beyond original, contract period subject to the following terms and conditions.

2.12.2 Rates shall be increased by 10% for the first twelve months of one or more extensions beyond original contract period. For the next twelve months of further extensions if any, rates shall be increased as above by 10% over the previous twelve months, and similarly for each subsequent twelve months extension.

2.12.3 Should there be any 'Time extension' for reasons attributable only to the contractor, then the work shall be executed by the contractor at the rates applicable for the period the work was planned

2.12.4 Payment of ORC shall be regulated as follows:

i) Contractor is entitled to Over Run Compensation (ORC) only for the portion of backlog attributable to BHEL.

ii) 50% of the compensation is allocated for deployment of resources agreed as per the joint programme drawn vide 2.11.4. Payment shall however be based on the actual deployment of resources for the month as certified by BHEL, as per weightages assigned therein

iii) 50% of the compensation, is allocated for achieving of planned progress agreed as per the joint programme drawn vide 2.11.4. Payment shall be on pro rata basis for actual achieved quantities

iv) Total Over Run Compensation shall be limited to 10% of the executed contract value as certified in Final Bill. For this purpose, executed contract value excludes PVC, ORC, Supplementary/Additional Items and Extra Works done on Man-day rate basis

2.12.5 Contractor shall not be entitled for any Over Run Compensation (ORC) for the portion of backlog attributable to the contractor. Such works shall be executed at the rates applicable for the period the work was planned

2.13 **QUANTITY VARIATION**

2.13.1 *The quoted rates shall remain firm irrespective of any variations in the individual quantities.*

2.14 **EXTRA WORKS**

2.14.1 *All rectifications/modifications, revamping, and reworks required for any reasons not attributable to the contractor, or needed due to any change in deviation from drawings and design of equipment, operation/maintenance requirements, mismatching, or due to damages in transit, storage and erection/commissioning, and other allied works which are not very specifically indicated in the drawings, but are found essential for satisfactory completion of the work, will be considered as extra works.*

2.14.2 *Extra works arising on account of the contractor's fault, irrespective of time consumed in rectification of the damage/loss, will have to be carried out by the contractor free of cost. Under such circumstances, any material and consumable required for this purpose will also have to be arranged by the contractor at his cost.*

2.14.3 *All the extra work should be carried out by a separately identifiable gang, without affecting routine activities. Daily log sheets in the pro-forma prescribed by BHEL should be maintained and shall be signed by the contractor's representative and BHEL engineer. No claim for extra work will be considered/entertained in the absence of the said supporting documents i.e. daily log sheets. Signing of log sheets by BHEL engineer does not necessarily mean the acceptance of such works as extra works.*

2.14.4 *BHEL retains the right to award or not to award any of the major repair/rework/modification/rectification/fabrication works to the contractor, at their discretion without assigning any reason for the same*

2.14.5 *After eligibility of extra works is established and finally accepted by BHEL engineer/designer, payment will be released on competent authority's approval at the following rate.*

MAN-HOUR RATE FOR ELIGIBLE EXTRA WORKS: *Single composite average labour manhour rate, including overtime if any, supervision, use of tools and tackles and other site expenses and incidentals, consumables for carrying out any major rework/repairs/rectification/modification/fabrication as certified by site as may arise during the course of erection, testing, commissioning or extra works arising out of transit, storage and erection damages, payment, if found due will be as per applicable minimum wage act*

2.14.6 *The above composite labour man hour rate towards extra works shall remain firm and not subject to any variation during execution of the work. PVC will not be applicable for extra works. Rate revision, Over Run Charges/compensation etc will not be applicable due to extra works.*

2.14.7 Extra Works for Civil Packages shall be regulated as follows

i) Rates for Extra Works arising due to (1) non availability of BOQ (Rate Schedule), OR (2) change in Specifications of materials/works (3) rectification/modification/dismantling & re-erecting etc due to no fault of Contractor, shall be in the order of the following:

a) Item rates are to be derived from similar nature of items in the BOQ (Rate Schedule) with applicable escalation derived from All India Consumer Price Index for Whole Sale Commodities.

b) As per applicable updated CPWD-DSR (or latest edition) with applicable escalation derived, Notification issued by the office of CPWD for 'Cost Index' in that Region where the project is being executed,

c) Item rates are to be worked out on the basis of prevailing market rates mutually agreed between BHEL and Contractor, plus 15% towards Contractor's overheads and profit.

ii) PVC and ORC will not applicable be for (i) above.

2.15 **SUPPLEMENTARY ITEMS**

2.15.1 For NON Civil Works

Supplementary items are items/works required for completion of entire work but not specified in the scope of work. Subject to certification of such items/works as supplementary items by BHEL Engineer, rates shall be derived on the basis of any one of the following on mutual agreement:

i) Based on percentage breakup/rates indicated for similar/nearby items

ii) In case (i) above does not exist, then BHEL/site may derive the percentage breakup/rates to suit the type of work

2.15.2 For Civil Works

i) Rates for Supplementary Works/Additional Works arising out due to additions/alterations in the original scope of works as per contract subject to certification of BHEL Engineer shall be worked out as under:

a) Item rates which are available in existing BOQ (Rate Schedule) shall be operated with applicable escalation derived from All India Consumer Price Index for Whole Sale Commodities

b) Items of works which are not available in existing BOQ shall be operated as an 'Extra Works' and rate shall be derived as per clause no 2.14



ii) Execution of Supplementary Works/Additional Works through the Contractor shall be at the sole discretion of BHEL, and shall be considered as part of executed contract value for the purpose of Quantity Variation as per clause 2.13

iii) BHEL Engineer's decision regarding fixing the rate as above is final and binding on the contractor. iv) PVC and ORC will not be applicable for (i) above.

2.16 STRIKES & LOCKOUT

2.16.1 The contractor will be fully responsible for all disputes and other issues connected with his labour/employee. In the event of the contractor's labour/employee resorting to strike or the Contractor resorting to lockout and if the strike or lockout declared is not settled within a period of 15 days, BHEL shall have the right to get the work executed through any other agencies and the cost so incurred by BHEL along with Overhead charges of 35% shall be deducted from the Contractor's bills along with overhead of 35%

2.16.2 For all purposes whatsoever, the employees of the contractor shall not be deemed to be in the employment of BHEL

2.17 FORCE MAJEURE

The following shall amount to Force Majeure: -

2.17.1 Acts of God, act of any Government, War, Sabotage, Riots, Strike, Civil commotion, Police action, Revolution, Flood, Fire, Cyclones, Earth quake and Epidemic and other similar causes over which the contractor has no control.

2.17.2 If the contractor suffers delay in the due execution of the contractual obligation due to delays caused by force majeure as defined above, the agreed time of completion of the job covered by this contract or the obligations of the contractor shall be extended by a period of time equal to period of delay, provided that on the occurrence of any such contingency, the contractor immediately reports to BHEL in writing the causes of delay and the contractor shall not be eligible for any compensation.

2.18 ARBITRATION & RECONCILIATION

2.18.1 In case amicable settlement is not reached in the event of any dispute or difference arising out of the execution of the Contract or the respective rights and liabilities of the parties or in relation to interpretation of any provision by the Contractor in any manner touching upon the Contract, such dispute or difference shall (except as to any matters, the decision of which is specifically provided for therein) be referred to the sole arbitration of the arbitrator appointed by BHEL/In charge.

The award of the Arbitrator shall be binding upon the parties to the dispute Subject as aforesaid, the provisions of Arbitration and Reconciliation Act 1996 (India) or statutory

modifications or reenactments thereof and the rules made there under and for the time being in force shall apply to the arbitration proceedings under this clause. The venue of the arbitration shall be the place from which the contract is issued or such other place as the Arbitrator at his discretion may determine

2.18.2 In case of Contract with Public Sector Enterprise (PSE) or a Government Department, the following shall be applicable:

In the event of any dispute or difference relating to the interpretation and application of the provisions of the Contract, such dispute or difference shall be referred to by either party to the arbitration of one of the arbitrators in the department of public enterprises. The award of the arbitrator shall be binding upon the parties to the dispute, provided, however, any party aggrieved by such award may make further reference for setting aside or revision of the award to the Law Secretary, Department of Legal Affairs, Ministry of Law and Justice, Government of India. Upon such reference the dispute shall be decided by the Law Secretary or the Special Secretary or Additional Secretary when so authorized by the Law Secretary, whose decision shall bind the parties hereto finally and conclusively.

2.18.3 The cost of arbitration shall be borne equally by the parties.

2.18.4 Work under the contract shall be continued during the arbitration proceedings

2.19 PAYMENTS

Payments to Contractors are made in any one of the following forms

2.19.1 Running Account Bills (RA Bills)

- i) These are for interim payments when the contracts are in progress. The bills for such interim payments are to be prepared by Contractor in prescribed formats (RA Bill forms).*
- ii) Payments shall be made according to the extent of work done as per measurements taken up to the end of the calendar month and in line with the terms of payments described in the Tender documents along with relevant statutory documents applicable for the work.*
- iii) Recoveries on account of electricity, water, statutory deductions, etc are made as per terms of contract*
- iv) Full rates for the work done shall be allowed only if the quantum of work has been done as per the specifications stipulated in the contract. If the work is not executed as per the stipulated specifications, BHEL may ask the contractor to re do the work according to the required specifications, without any extra cost. However, where this is not considered necessary 'OR' where the part work is done due to factors like non-availability of material to be supplied by BHEL 'OR' non availability of fronts 'OR' non availability of drawings, fraction payment against full rate, as is considered reasonable, may be allowed with due regard for*



the work remaining to be done. BHEL decision in this regard will be final and binding on the contractor.

v) In order to facilitate part payment, BHEL Site Engineer at his discretion may further split the contracted rates/percentages to suit site conditions, cash flow requirements according to the progress of work

2.19.2 Final Bill

'Final Bill' is used for final payment on closing of Running Account for works or for single payment after completion of works. 'Final Bill' shall be submitted as per prescribed format after completion of works as per scope and upon material reconciliation, along with the following.

i) 'No Claim Certificate' by contractor

ii) Clearance certificates where ever applicable viz Clearance Certificates from Customer, various Statutory Authorities like Labour department, PF Authorities, Commercial Tax Department, etc

iii) Indemnity bond as per prescribed format BHEL shall settle the final bills after deducting all liabilities of Contractor to BHEL

2.20 PERFORMANCE GUARANTEE FOR WORKMANSHIP

2.20.1 Even though the work will be carried out under the supervision of BHEL Engineers the Contractor will be responsible for the quality of the workmanship and shall guarantee the work done for a period of as mentioned in the contract/NIT from the date of commencement of guarantee period as defined in Technical Conditions of Contract, for good workmanship and shall rectify free of cost all defects due to faulty erection detected during the guarantee period. In the event of the Contractor failing to repair the defective works within the time specified by the Engineer, BHEL may proceed to undertake the repairs of such defective works at the Contractor's risk and cost, without prejudice to any other rights and recover the same from the balance security deposit.

2.20.2 BHEL shall release the balance security deposit subject to the following

i) Contractor has submitted 'Final Bill'

ii) Guarantee period as per contract has expired

iii) Contractor has furnished 'No Claim Certificate' in specified format

iv) BHEL Site Engineer/Construction Manager has furnished the 'No Demand Certificate' in specified format



v) Contractor has carried out the works required to be carried out by him during the period of Guarantee and all expenses incurred by BHEL on carrying out such works is included for adjustment from the Guarantee money refundable.

2.21 CLOSING OF CONTRACTS

The Contract shall be considered completed and closed upon completion of all contractual obligations and settlement of Final Bill or completion of Guarantee period whichever is later. Upon closing of Contract, BHEL shall issue a completion certificate as per standard format, based on specific request of Contractor.

2.22 REVERSE AUCTION/PRICE BID OPENING:

- BHEL reserves the right to go for reverse auction at any point of time before opening of Price Bid.
- Bids with non-acceptance of reverse auction will be liable for rejection.
- Opening of Price Bid at discretion of BHEL.
- BHEL shall be at liberty to cancel the tender at any time, before ordering, without assigning any reason.

2.23 SUSPENSION OF BUSINESS DEALINGS

BHEL reserves the right to take action against Contractors who either fail to perform or Tenderers/Contractor who indulge in malpractices, by suspending business dealings with them in line with BHEL guidelines issued from time to time.

2.24 OTHER ISSUES

2.24.1 Value of Non judicial Stamp Paper for Bank Guarantees and for Contract Agreement shall be not less than Rs 200/- unless otherwise required under relevant statutes.

2.24.2 In case of any conflict between the General Conditions of Contract and Special Conditions of Contract, provisions contained in the Special Conditions of Contract shall prevail.

2.24.3 Unless otherwise specified in NIT, offers from consortium/JVs shall not be considered.

2.24.4 BHEL may not insist for signing of Contract Agreements in respect of low value and short time period contracts



GUIDELINES FOR REVERSE AUCTION - 2024

(AA:SSP:RA:00 dated 05.12.2024)

ABRIDGED VERSION

BHEL, New Delhi

Guidelines for Reverse Auction – 2024

Doc. No. AA:SSP:RA:00
Dated: 05.12.2024

1.0 Scope

This document describes the guidelines to be followed by BHEL for conducting Reverse Auction (RA) for procurement of material/ works/ services. The RA shall follow the philosophy of English Reverse (No ties).

English Reverse (No ties) is a type of auction where the starting price and bid decrement are announced before start of online reverse auction. The interested bidders can thereupon start bidding in an iterative process wherein the lowest bidder at any given moment can be displaced by an even lower bid of a competing bidder, within a given time frame. The bidding is with reference to the current lowest bid in the reverse auction. All bidders will see the current lowest quoted price and their rank. The term 'No ties' is used since more than one bidder cannot give an identical price, at a given instant, during the reverse auction. In other words, there shall never be a tie in the bids.

3.0 Upfront declaration in NIT

Decision to go for RA would be taken before floating of the tender. In case it is decided to go for RA, same shall be declared upfront in NIT by inserting the following **clause**:

"BHEL shall be resorting to Reverse Auction (RA) (Guidelines as available on www.bhel.com) for this tender. RA shall be conducted among the techno-commercially qualified bidders.

Price bids of all techno-commercially qualified bidders shall be opened and same shall be considered for RA. In case any bidder(s) do(es) not participate in online Reverse Auction, their sealed price bid along with applicable loading, if any, shall be considered for ranking."

6.0 Business rules for RA

Model Annexure-I is attached.

7.0 Role of Service Provider

- (1) Acknowledge the receipt of mandate from BHEL.
- (2) Contact the bidders, provide business rules and train them, as required.
- (3) Get the process compliance form (annexure III) signed by all the

Guidelines for Reverse Auction – 2024

Doc. No. AA:SSP:RA:00
Dated: 05.12.2024

-
- participating bidders before RA event.
 - (4) Conduct the event as per the contract and business rules.
 - (5) Submit the Login Reports, Results, History sheet and authorized final bid from the bidders.
 - (6) To obtain price breakup from successful bidder and submit the same to BHEL.

10.0 Reverse Auction Process

- 10.1. Reverse Auction will be conducted if two or more bidders are techno-commercially qualified.
- 10.2. Wherever RA is opted in a tender, the techno-commercially qualified H1 will not be allowed to participate in RA. In case more than one H1 bidder quote the same rate, the Price Offer received last, as per the time log of the Portal, shall be removed first, on the principle of last in, first out by the system.
- 10.3. However, H1 will be allowed to participate in RA in the following cases:
 - a) If number of techno-commercially qualified bidders are only 2 or 3.
 - b) In case Primary product of only one OEM is left in contention for participation in RA on elimination of H1.
 - c) For cases where there are more than 3 techno-commercially qualified bidders, if lowest bidder in sealed price bid is non-MSE and H-1 is eligible MSE and H-1 price is coming within price band of 15% of Non-MSE lowest bidder.
 - d) For cases where there are more than 3 techno-commercially qualified bidders, if lowest bidder in sealed price bid is non-MII and H-1 is eligible MII and H-1 price is coming within price band of 20% of Non-MII lowest bidder.
- 10.4. Only those bidders who submit the online sealed bid within the scheduled time shall be eligible to participate further in the RA process.
- 10.7. During RA, all bidders will see their rank and current L1 price on the screen. Once the RA is done, the ranking status would be based on the last quoted price of the bidder(s) irrespective of the quote received in RA or sealed price bid.

Guidelines for Reverse Auction – 2024

Doc. No. AA:SSP:RA:00
Dated: 05.12.2024

10.8 No bidder shall be allowed to lower its bid below the current L1 by more than 5 decrements at one go.

13.0 Others

13.2 In case of enquiry through e-Procurement, the sealed electronic price bid (e-bid) is to be treated as sealed price bid.

13.3 BHEL will inform bidders the details of service provider who will provide business rules, all necessary training and assistance before commencement of online bidding.

13.4 Bidders will be advised to read the 'Business Rules' indicating details of RA event carefully, before reverse auction event.

---XXX---

ABRIDGED VERSION

Guidelines for Reverse Auction – 2024

Doc. No. AA:SSP:RA:00

Dated: 05.12.2024

Business Rules for Reverse Auction

Annexure – I

This has reference to tender no **{tender number....date...}**. BHEL shall finalise the Rates for the supply of **{item name}** through Reverse Auction mode. BHEL has made arrangement with M/s. **{Service provider}**, who shall be BHEL's authorized service provider for the same. Bidders should go through the instructions given below and submit acceptance of the same.

The technical & commercial terms are as per (a) BHEL Tender Enq. No. {...} dated {...}, (b) Bidders' technical & commercial bid (in case of two part bid) and (c) subsequent correspondences between BHEL and the bidders, if any.

1. Procedure of Reverse Auctioning

- i. Price bids of all techno-commercially qualified bidders shall be opened.
- ii. **Reverse Auction:** The 'bid decrement' will be decided by BHEL.
- iii. The lowest bidder in sealed price bid shall be shown as current L1 automatically by the system and no acceptance of that price is required. System shall have the provision to indicate this bid as current L1.
- iv. Bidders by offering a minimum bid decrement or the multiples thereof can displace a standing lowest bid and become "L1" and this continues as an iterative process. However, no bidder shall be allowed to lower its bid below the current L1 by more than 5 decrements at one go.
- v. After the completion of the reverse auction, the Closing Price shall be available for further processing.
- vi. Wherever the evaluation is done on total cost basis, after Reverse Auction, prices of individual line items shall be reduced on pro-rata basis.

2. Schedule for reverse auction: The Reverse Auction is tentatively scheduled on **{date}: ;{start time}: ;{Close Time}: }**.

3. Auction extension time: If a bidder places a bid in the last {...} minutes of closing of the Reverse Auction and if that bid gets accepted, then the auction's duration shall get extended automatically for another {...} minutes,

Guidelines for Reverse Auction – 2024

Doc. No. AA:SSP:RA:00

Dated: 05.12.2024

Business Rules for Reverse Auction

Annexure – I

for the entire auction (i.e. for all the items in the auction), from the time that bid comes in. Please note that the auto-extension will take place only if a bid comes in those last {...} minutes and if that bid gets accepted as the lowest bid. If the bid does not get accepted as the lowest bid, the auto-extension will not take place even if that bid might have come in the last {...} minutes. In case, there is no bid in the last {...} minutes of closing of Reverse Auction, the auction shall get closed automatically without any extension. However, bidders are advised not to wait till the last minute or last few seconds to enter their bid during the auto-extension period to avoid complications related with internet connectivity, network problems, system crash down, power failure, etc.

The above process will continue till completion of Reverse Auction.

Complaints/ Grievances, if any, regarding denial of service or any related issue should be given in writing thru e-mail/ fax to M/s. {Service provider} with a copy to BHEL within 15 minutes prior to initial closing time of Reverse Auction.

4. **Bid price:** The Bidder has to quote the {.....} Price inclusive of Packing & Forwarding charges, all the routine & type tests as per tender scope, taxes, duties, freight and insurance as specified in tender document, including loading (if indicated by BHEL due to deviations in technical/ commercial terms) for the Items specified. Details are as shown in Excel Sheet for calculation of total cost to BHEL (To be specified by Unit as per NIT conditions).
5. **Bidding currency and unit of measurement:** Bidding will be conducted in *Indian Rupees per Unit* of the material as per the specifications {...}

In case of foreign currency bids, exchange rate (TT selling rate of State Bank of India) as on scheduled date of tender opening (Part-I bid) shall be considered for conversion in Indian Rupees. If the relevant day happens to be a Bank holiday, then the forex rate as on the previous bank (SBI) working day shall be taken.

6. **Validity of bids:** Price shall be valid for {... days} from the date of reverse auction. These shall not be subjected to any change whatsoever.

Guidelines for Reverse Auction – 2024

Doc. No. AA:SSP:RA:00
Dated: 05.12.2024

Business Rules for Reverse Auction

Annexure – I

-
7. **Lowest bid of a bidder:** In case the bidder submits more than one bid, the lowest bid at the end of Reverse Auction will be considered as the bidder's final offer to execute the work.
 8. Unique user IDs shall be used by bidders during bidding process. All bids made from the Login ID given to the bidders will be deemed to have been made by the bidders/ bidders' company.
 9. **Post auction procedure:** BHEL will proceed with the Lowest Bid in the Reverse Auction for further processing.
 10. Any commercial/ technical loading shall be separately intimated to respective bidders prior to RA. The excel sheet provided in this regard shall cover all these aspects. Commercial/ technical loading if any, shall be added by the respective bidder in its price during Reverse Auction. Modalities of loading & de-loading shall be separately intimated to the bidders. The responsibility for correctness of total cost to BHEL shall lie with the bidders.
 11. Reverse auction shall be conducted by BHEL (through M/s {Service Provider}), on pre-specified date, while the bidders shall be quoting from their own offices/ place of their choice. Internet connectivity shall have to be ensured by bidders themselves.

During the RA process if a bidder is not able to bid and requests for extension of time by FAX/ email/ phone then time extension of additional 15 minutes will be given by the service provider provided such requests come before 5 minutes of auction closing time. However, only one such request per bidder can be entertained.

In order to ward-off contingent situation of connectivity failure bidders are requested to make all the necessary arrangements/ alternatives whatever required so that they are able to circumvent such situation and still be able to participate in the reverse auction successfully. Failure of power or loss of connectivity at the premises of bidders during the Reverse auction cannot be the cause for not participating in the reverse auction. On account of this, the time for the auction cannot be extended and neither BHEL nor M/s. {Service provider} is responsible for such eventualities.

Guidelines for Reverse Auction – 2024

Doc. No. AA:SSP:RA:00

Dated: 05.12.2024

Business Rules for Reverse Auction

Annexure – I

-
- 12.** Proxy bids: Proxy bidding feature is a pro-bidder feature to safe guard the bidder's interest of any internet failure or to avoid last minute rush. The proxy feature allows bidders to place an automated bid in the system directly in an auction and bid without having to enter a new amount each time a competing bidder submits a new offer. The bid amount that a bidder enters is the minimum that the bidder is willing to offer. Here the software bids on behalf of the bidder. This obviates the need for the bidder participating in the bidding process until the proxy bid amount is decrementally reached by other bidders. When proxy bid amount is reached, the bidder (who has submitted the proxy bid) has an option to start participating in the bidding process.

The proxy amount is the minimum amount that the bidder is willing to offer. During the course of bidding, the bidder cannot delete or change the amount of a proxy bid.

Bids are submitted in decrements (decreasing bid amounts). The application automates proxy bidding by processing proxy bids automatically, according to the decrement that the auction originator originally established when creating the auction, submitting offers to the next bid decrement each time a competing bidder bids, regardless of the fact whether the competing bids are submitted as proxy or standard bids. However, it may please be noted that if a manual bid and proxy bid are submitted at the same instant manual bid will be recognized as the L1 at that instant.

In case of more than one proxy bid, the system shall bid till it crosses the threshold value of 'each lowest proxy bid' and thereafter allow the competition to decide the final L1 price.

Proxy bids are fed into the system directly by the respective bidders. As such this information is privy only to the respective bidder(s).

- 13.** Bidders are advised to get fully trained and clear all their doubts such as refreshing of Screen, quantity being auctioned, tender value being auctioned etc from M/s {Service provider}.
- 14.** M/s. {Service provider}, shall arrange to demonstrate/ train the bidder or bidder's nominated person(s), without any cost to bidders. M/s. {Service provider}, shall also explain the bidders, all the business rules related to the
-

Guidelines for Reverse Auction – 2024

Doc. No. AA:SSP:RA:00

Dated: 05.12.2024

Business Rules for Reverse Auction

Annexure – I

Reverse Auction. Bidders are required to submit their acceptance to the terms/ conditions/ modalities before participating in the Reverse Auction in the process compliance form as enclosed. Without this, the bidder will not be eligible to participate in the event.

15. Successful bidder shall be required to submit the final prices (L1) in prescribed format (Annexure – VI) for price breakup, quoted during the Reverse Auction, duly signed and stamped as token of acceptance without any new condition (other than those already agreed to before start of auction), after the completion of auction to M/s. {Service provider} besides BHEL within two working days of Auction without fail.
16. Any variation between the final bid value and that in the confirmatory signed price breakup document will be considered as tampering the tender process and will invite action by BHEL as per extant guidelines for suspension of business dealings (as available on www.bhel.com).
17. Bidders' bid will be taken as an offer to execute the work/ supplies the item as per enquiry no. {...} dt. {...}. Bids once made by the bidder, cannot be cancelled/ withdrawn and bidder shall be bound to execute the work as mentioned above at bidder's final bid price. Should bidder back out and not execute the contract as per the rates quoted, BHEL shall take action as per extant guidelines for suspension of business dealings (as available on www.bhel.com).
18. Bidders shall be able to view the following on their screen along with the necessary fields during Reverse Auction:
 - a. Leading (Running Lowest) Bid in the Auction (only total price of package)
 - b. Bid Placed by the bidder
 - c. Start Price
 - d. Decrement value
 - e. Rank of their own bid during bidding as well as at the close of auction.
19. BHEL's decision on award of contract shall be final and binding on all the Bidders.
20. BHEL reserves the right to extend, reschedule or cancel the Reverse Auction process at any time, before ordering, without assigning any reason, with

Guidelines for Reverse Auction – 2024

Doc. No. AA:SSP:RA:00

Dated: 05.12.2024

Business Rules for Reverse Auction

Annexure – I

intimation to bidders.

21. BHEL shall not have any liability to bidders for any interruption or delay in access to the site irrespective of the cause. In such cases, the decision of BHEL shall be binding on the bidders.
22. Other terms and conditions shall be as per bidder's techno-commercial offers and other correspondences, if any, till date.
23. If there is any clash between this business document and the FAQ available, if any, in the website of M/s. {Service provider}, the terms & conditions given in this business document will supersede the information contained in the FAQs. Any changes made by BHEL/ service provider (due to unforeseen contingencies) after the first posting shall be deemed to have been accepted if the bidder continues to access the portal after that time.
24. Bidder shall not divulge either his Bids or any other exclusive details of BHEL to any other party. If the Bidder or any of his representatives are found to be involved in Price manipulation/ cartel formation of any kind, directly or indirectly by communicating with other bidders, action as per extant BHEL guidelines for suspension of business dealings (as available on www.bhel.com), shall be initiated by BHEL.