

Tender No. F/T237/22/1298/R1

BHARAT HEAVY ELECTRICALS LIMITED
HEEP HARIDWAR INDIA-PIN 249403
FAX NO: 0091 1334 226462/223948
PHONE NO: 0091 1334 284144

Tender No.: F/T237/22/1298/R1

Opening Date: 23.09.2022

Sub: BHEL-HEEP/OPEN-TENDER (Anchor Rod Assembly)

The Heavy Electricals Equipment Plant (HEEP) located in Haridwar, India is one of the major manufacturing plants of Bharat Heavy Electricals Ltd. The core business of HEEP includes design and manufacture of large steam turbines, turbo generators and so on.

For this procurement, the local content to categorize a supplier as a Class I local supplier/ Class II local supplier/ Non- Local supplier and purchase preference to Class I local supplier, is as defined in Public Procurement (Preference to Make in India), Order 2017 dated 16.09.2020 issued by DPIIT (Annexure- VI). In case of subsequent orders issued by the nodal ministry, changing the definition of local content for the items of the NIT, the same shall be applicable even if issued after issue of this NIT, but before opening of Part-II bids against this NIT.

Only ‘Class- I local supplier’ and ‘Class- II local supplier’, as defined under the order 2017 dt. 16.09.2020 (Annexure- VI) shall be eligible to bid in this procurement and must submit self-certification for local content (Annexure- VII).

Online offers are invited through e-procurement portal <https://eprocurebhel.co.in/nicgep/app> from suppliers for the supply of the following items: -

Sl. No.	Item Description	Material Code & Drawing	Size (mm)	Qty. (No)
1	ANCHOR ROD ASSEMBLY DIA 32 CONSIST OF 1 NO. OF ANCHOR ROD DIA 32 (ITEM NO.1), 1 NO. OF HEXAGCON COUPLER DIA 32 (ITEM NO.2), 2NO. OF FIX NUT DIA 32 (ITEM NO. 3) & 1 NO. OF ANCHOR NUT DIA 32 (ITEM NO. 4) AS PER DRAWING NO. 31240250124	W97312402038 DRG: 31240250124 REV: 02	φ- 32	88
2	ANCHOR ROD ASSEMBLY DIA 36 CONSIST OF 1 NO. OF ANCHOR ROD DIA 36 (ITEM NO.1), 1 NO. OF HEXAGCON COUPLER DIA 36 (ITEM NO.2), 2NO. OF FIX NUT DIA 36 (ITEM NO. 3) & 1 NO. OF ANCHOR NUT DIA 36 (ITEM NO. 4) AS PER DRAWING NO. 31240250324	W97312402046 DRG: 31240250324 REV: 02	φ- 36	40

The Techno-Commercial offers received will be evaluated by BHEL & successful short-listed parties will be asked to supply the item as per tender document. Vendors shall confirm that there is no deviation with respect to BHEL Specifications. However, deviations, if any are to be listed as a separate attachment. The offers that do not meet the substantial requirements of our specifications are liable to be ignored.

The tender documents can be downloaded from <https://eprocurebhel.co.in/nicgep/app>, <https://hwr.bhel.com> and www.bhel.com portals. **Only those vendors who fulfill the Minimum Qualifying Requirements (as per Annexure-II) will be considered for further technical evaluation.**

The last date for downloading tender documents shall be 22.09.2022 & opening of tender shall be 23.09.2022. Tenders will be received up to 01.45 P.M. on 22.09.2022 and opened on 23.09.2022 at 2.00 P.M. on <https://eprocurebhel.co.in/nicgep/app> . **Please note that tender received after 01.45 PM on 22.09.2022 will not be opened.** BHEL will not be responsible for any type of delay.

Tender No. F/T237/22/1298/R1

Intending vendors must remit requisite EMD 100,000/- (Rupees One Hundred thousand only) in the form of pay order or bank draft while submitting the tender documents as detailed in "Instruction to Bidders", after downloading from this web site. Please submit DRAFTS FOR EMD DRAWN IN FAVOUR OF BHARAT HEAVY ELECTRICALS LTD. HEPP, HARIDWAR. E-payment may also be accepted as EMD. Details of BHEL account as per following-

Bank Details	SWIFT Details of bank	Contact Details of Banker
STATE BANK OF INDIA RANIPUR BRANCH, OPP: BHEL MAIN GATE, SECTOR-5, RANIPUR, HARIDWAR, UTTRAKHAND, INDIA PIN CODE: 249403	SWIFT NO: SBININBB225 CC ACCOUNT NO: 10667995458 IFSC CODE: SBIN0000586	Chief Manager (IBD) Contact No. +91 1334 224201 +91 1334 226125 Fax: +91 1334 226512

EMD is waived off for-

- a) Central/ State – PSUs/ Government departments
- b) As per government guidelines, MSE suppliers are exempted for submission of EMD (Valid Documentary proof against MSE must be submitted along with offer to avail the benefits).

The total quantity may undergo change at the time of ordering.

The details of each item with required delivery are given in **Annexure-I (Details of Items)**

Please submit your Techno-Commercial offer only for the above requirement subject to our terms and conditions.

IN ADDITION TO VENDORS MENTIONED ABOVE, OFFERS SHALL ONLY BE CONSIDERED OF THOSE VENDORS WHO WILL SUBMIT EMD.

KINDLY READ "INSTRUCTIONS TO BIDDERS." QUOTATION NOT IN ACCORDANCE WITH THE INSTRUCTIONS ARE LIABLE TO BE DISQUALIFIED AND IGNORED.

INSTRUCTIONS TO BIDDERS FOR OPEN TENDER

Vendors must fill up Annexure– II in confirmation to mandatory Pre- Qualification Requirements and quality requirements.

ESSENTIAL INSTRUCTIONS

1. **BHEL team may visit the vendor (s) works for verification of capability and capacity claimed in tender documents/offer (s).**
2. The tenders shall be submitted in two parts
 - i. Part I - Techno -Commercial Bid & Pre-Qualification Requirement,
 - ii. Part II - Price Bid
3. **Procurement directly from the manufacturers/ suppliers shall be preferred. However, if the OEM/ Principal insists on engaging the services of an agent following to be followed-**
 - a. Either the agent could bid on behalf of the manufacturer/ supplier or the manufacturer/ supplier could bid directly but not both.
 - b. In case bids are received from both the manufacturer/ supplier and the agent, bid received from the agent shall be ignored.
 - c. The agent shall not be allowed to represent more than one manufacturer/ supplier in the same tender.
4. Documents submitted with the offer/bid by the bidder shall be signed and stamped in each page by authorized representative of the bidder.
5. Any corrections / amendments shall be properly & fully authenticated with signature. No overwriting is acceptable.
6. Part-I containing Techno-Commercial bid & Pre-Qualification Requirement will be opened on the date and time specified in the tender notice in the presence of those vendors who wish to attend.
7. Part-II (Price Bids) along with supplementary price bids, if necessary, will be opened at a later date of only those bidders whose techno-commercial bid has been found acceptable.
8. Suitability of delivery shall be the important criteria for evaluation of techno commercial bid.
9. **Evaluation of Bid: - The bid shall be evaluated**
 - a. **Cost to BHEL basis. (Basic Cost + Inspection + Transportation + Duty + Taxes)**
 - b. **The loading, if any, on account of LD penalty, payment terms or any other cost determined at later stage, which shall be communicated to the vendor.**
10. Tenders when finalized shall be in the name of the bidder only and change of name during tender evaluation (without certificate from registrar of company) and after submission of the tender is liable to make the offer ineligible for participation.
11. All test certificates / Guarantee certificates to be submitted in TRIPLICATE along with dispatch documents.
12. BHEL reserves the right to open the price bid (part-II) along with the opening of techno-commercial offer at its option and in that case vendor will be informed accordingly.
13. Total weight--/Gross/Net in Kg & also package size essentially should be indicated if not exact then approximate.
14. BHEL will evaluate the technical bids against essential criteria/requirements. BHEL may seek clarifications, if required, from the qualified bidders only. These clarifications will be communicated to the eligible vendors. **The offers of those bidders, who are unable to respond in specified time frame, are likely to be ignored.**

Note: Please visit our site <https://hwr.bhel.com> for General Instructions and Standard Terms & Conditions (GISTC) for Tender Enquiries. All the bidders / vendors must ensure compliance of latest GISTC.

GISTC are available in following link

<https://hwr.bhel.com/bhelweb/Gistc.jsp>

IN CASE YOU ARE NOT MAKING AN OFFER AGAINST THIS ENQUIRY, THEN PLEASE ARRANGE TO SEND A LETTER OF REGRET.

For clarification regarding tender, please contact following persons:

- | | |
|---|--|
| 1) P K Bansal / Sr. Engineer (PPX- F)
4 th Floor Main ADM Building
BHEL (HEEP), Haridwar
Phone No.- 01334284144
Mob No- 7533968681
Email- pankajkumar.bansal@bhel.in | 2) Pankaj Yadav / Manager (PPX- F)
4 th Floor Main ADM Building
BHEL (HEEP), Haridwar
Phone No.- 01334281032
Mob No- 9442275514
Email- pankaj.yadav@bhel.in |
|---|--|

DETAILS OF COMPOSITION OF PART-I (TECHNO-COMMERCIAL BID) & PART-II (PRICE BID)

PART-I (TECHNO-COMMERCIAL BID) shall comprise of following documents:

- a. Confirmation to Pre- Qualification Requirement and Quality Requirement as per Annexure-II.
- b. Complete technical offer as per specification, drawings, technical requirement along with un-priced bid.
- c. Delivery schedule.
- d. Validity of offer for 90 days to be indicated.
- e. **Deviation with reference to specification/drawing, if any, should be clearly indicated on a separate sheet.**
- f. Details of activity outsourced.

PART –II (Price Bid)

- a. Price bid with prices to be submitted as part-II of the tender.
- b. Prices should remain firm till the execution of the order.
- c. **Prices may be quoted on FOR- Destination- Store-HEEP-BHEL basis. In case BHEL accepts the EX-Works prices such offers will be loaded by 1.5% of EX-Works value towards freight or with actual freight charges as per BHEL freight rate contract whichever is higher.**
- d. Insurance – Inland insurance shall be taken care by BHEL.
- e. **Prices are to be written in both Figures & Words. In case of any difference between the two, the figure written in words shall be considered for evaluation. No over writing in this is acceptable.**
- f. Liquidated Damages (LD) for Late Deliveries shall be applicable @0.5% per week or part thereof on the value of respective delayed supplies subject to a maximum of 10% of the value of respective delayed supplies.

ANNEXURE-I**Item Details and Delivery Schedule**

Sl. No.	Item Description	Mat. Code &	Size (mm)	Qty. (No)	Delivery
1	ANCHOR ROD ASSEMBLY DIA 32 CONSIST OF 1 NO. OF ANCHOR ROD DIA 32 (ITEM NO.1), 1 NO. OF HEXAGCON COUPLER DIA 32 (ITEM NO.2), 2NO. OF FIX NUT DIA 32 (ITEM NO. 3) & 1 NO. OF ANCHOR NUT DIA 32 (ITEM NO. 4) AS PER DRAWING NO. 31240250124	W97312402038 DRG: 31240250124 REV: 02	φ- 32	88	15.12.2022
2	ANCHOR ROD ASSEMBLY DIA 36 CONSIST OF 1 NO. OF ANCHOR ROD DIA 36 (ITEM NO.1), 1 NO. OF HEXAGCON COUPLER DIA 36 (ITEM NO.2), 2NO. OF FIX NUT DIA 36 (ITEM NO. 3) & 1 NO. OF ANCHOR NUT DIA 36 (ITEM NO. 4) AS PER DRAWING NO. 31240250324	W97312402046 DRG: 31240250324 REV: 02	φ- 36	40	

Remarks-

1. Bids will be evaluated on item wise basis.
2. Risk purchase clause shall be applicable. If you do not confirm this in your offer, then it shall be presumed to be acceptable and no further confirmation will be taken after opening of techno-commercial bid part- 1.
3. After placement of order vendor should submit their invoices against goods and services immediately after supply of goods & services but not later than 30 days from the invoice date. In case of any delay, consequential losses like loss of input credit and non-availability of concessional forms etc., shall be to the vendor account.
4. Liquidated Damages (LD) for Late Deliveries shall be applicable @0.5% per week or part thereof on the value of respective delayed supplies subject to a maximum of 10% of the value of respective delayed supplies.
5. NOTE: THE QUANTITY INDICATED ABOVE CAN BE INCREASED/ DECREASED.

ANNEXURE-II

Pre-Qualification Requirements for Anchor Rods Assembly (For Material Codes: W97312402038 & W97312402046)

➤ **Pre-Qualification Requirement for Anchor Rod with Nut-**

Description

Anchor Rods Assembly is specifically designed item used in Anchor Boxes to fix the Bearing Pedestals of steam turbine to the foundation Deck and these items go inside the concrete as special embedment. Stability of the Turbine depends on these Anchor Rods and Nut. These Anchor Rod assemblies consist of threaded Anchor Rods with matching Hexagonal Coupler, Anchor Nut & Fix nuts having internal threads (Refer below pictorial representation).

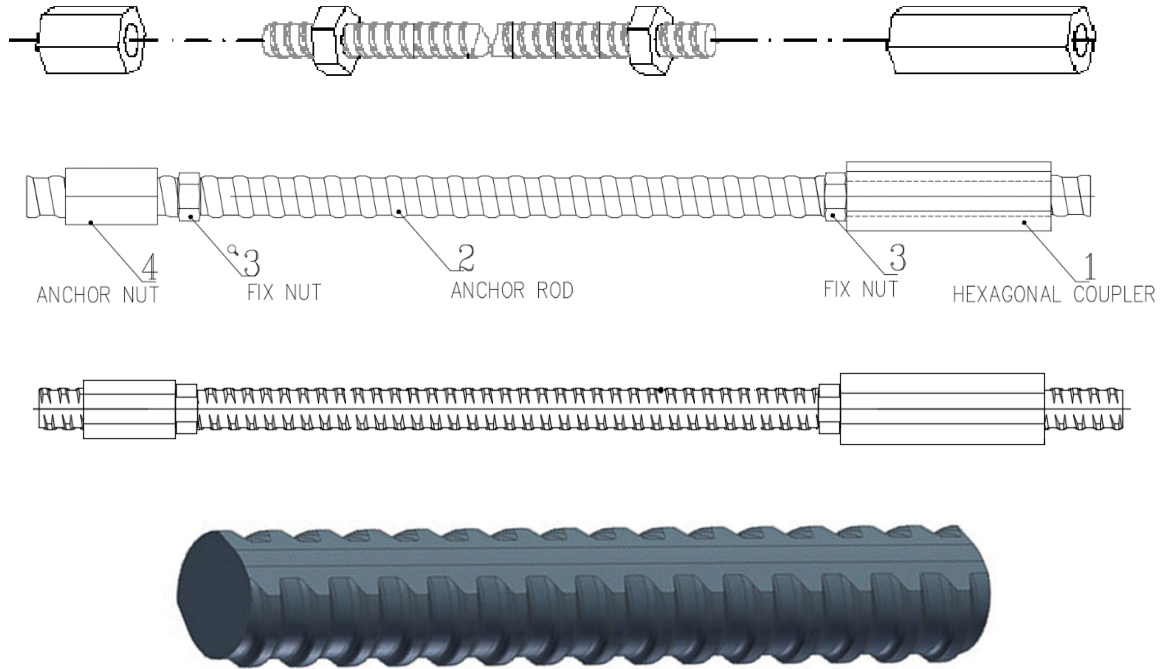

Qualification Criteria

The vendors meeting the below mentioned criteria shall be considered for further evaluation. Vendor to state its response as per Format below:

Sr. No.	Pre-Qualification Requirements	Vendor Response															
1	<p>Vendor must have experience of supplying post tensioned threaded Anchor Rod (hot rolled and proof stressed alloy steel having uniformly spaced threaded Rod) of nominal diameter 32 & 36 mm meeting the mechanical properties as below and conforming rest of all the details as per ASTM A722, prEN 10138-1 & prEN 10138-4 or equivalent and supplied to OEMs of Steam Turbine/Nuclear Turbine/Gas Turbine etc. of rating 200MW & higher or Civil Construction Industry (having application in pre-stressing concrete building construction).</p> <table border="1" style="width: 100%; border-collapse: collapse; margin-top: 10px;"> <thead> <tr> <th style="width: 35%;">Properties</th> <th style="width: 30%;">Anchor Rod (Nominal Diameter: 32 mm)</th> <th style="width: 35%;">Anchor Rod (Nominal Diameter: 36 mm)</th> </tr> </thead> <tbody> <tr> <td>Tensile Strength (N/mm²)</td> <td style="text-align: center;">≥ 1050</td> <td style="text-align: center;">≥ 1050</td> </tr> <tr> <td>Yield Strength (N/mm²)</td> <td style="text-align: center;">≥ 950</td> <td style="text-align: center;">≥ 950</td> </tr> <tr> <td>Design Load (KN)</td> <td style="text-align: center;">≥ 705</td> <td style="text-align: center;">> 908</td> </tr> <tr> <td>Elongation at maximum force</td> <td style="text-align: center;">≥ 5%</td> <td style="text-align: center;">≥ 5%</td> </tr> </tbody> </table> <p>Anchor rods must be bonded bar tendon and used as an embedment in concrete.</p>	Properties	Anchor Rod (Nominal Diameter: 32 mm)	Anchor Rod (Nominal Diameter: 36 mm)	Tensile Strength (N/mm ²)	≥ 1050	≥ 1050	Yield Strength (N/mm ²)	≥ 950	≥ 950	Design Load (KN)	≥ 705	> 908	Elongation at maximum force	≥ 5%	≥ 5%	YES/NO
Properties	Anchor Rod (Nominal Diameter: 32 mm)	Anchor Rod (Nominal Diameter: 36 mm)															
Tensile Strength (N/mm ²)	≥ 1050	≥ 1050															
Yield Strength (N/mm ²)	≥ 950	≥ 950															
Design Load (KN)	≥ 705	> 908															
Elongation at maximum force	≥ 5%	≥ 5%															

2	<p>The Vendor should have experience of supplying at least 25 nos. each of fully finished Anchor Rods Assembly of Nominal Diameter = 32 & 36 mm respectively, having length ≥ 1500 mm in the last 10 years from the date of issuance of enquiry and successfully executed 2 different Purchase Orders for each diameter of Anchor Rod Assembly (fulfilling requirements as mentioned at Sl. No. 1). Vendor to provide details of past executed Purchase Orders in the format given in Table-1 below:</p> <p style="text-align: center;">Table-1</p> <table border="1" style="width: 100%; border-collapse: collapse;"> <thead> <tr> <th style="width: 5%;">Sl.</th> <th style="width: 15%;">Name of Customer</th> <th style="width: 15%;">Detailed Address</th> <th style="width: 15%;">Name, Phone no. and email - Id of contact person</th> <th style="width: 10%;">Purchase order No.</th> <th style="width: 10%;">Date of Supply</th> <th style="width: 10%;">Size & material of Threaded Anchor Rod (Dia. & Length)</th> <th style="width: 5%;">Type of Thread</th> <th style="width: 10%;">Nominal Tensile strength & Yield Strength of Anchor Rod (N/mm²)</th> <th style="width: 5%;">Qty.</th> </tr> </thead> <tbody> <tr><td> </td><td> </td><td> </td><td> </td><td> </td><td> </td><td> </td><td> </td><td> </td><td> </td></tr> <tr><td> </td><td> </td><td> </td><td> </td><td> </td><td> </td><td> </td><td> </td><td> </td><td> </td></tr> <tr><td> </td><td> </td><td> </td><td> </td><td> </td><td> </td><td> </td><td> </td><td> </td><td> </td></tr> <tr><td> </td><td> </td><td> </td><td> </td><td> </td><td> </td><td> </td><td> </td><td> </td><td> </td></tr> </tbody> </table>	Sl.	Name of Customer	Detailed Address	Name, Phone no. and email - Id of contact person	Purchase order No.	Date of Supply	Size & material of Threaded Anchor Rod (Dia. & Length)	Type of Thread	Nominal Tensile strength & Yield Strength of Anchor Rod (N/mm ²)	Qty.																																									Format Filled: YES/NO
Sl.	Name of Customer	Detailed Address	Name, Phone no. and email - Id of contact person	Purchase order No.	Date of Supply	Size & material of Threaded Anchor Rod (Dia. & Length)	Type of Thread	Nominal Tensile strength & Yield Strength of Anchor Rod (N/mm ²)	Qty.																																											
3	<p>Vendor has to submit documentary evidence in support of experience details submitted in Table-1:</p> <p>I. Unpriced Purchase Order Copies (2 nos. for each diameter of Anchor Rod Assembly as per above details provided in Table)</p> <p>II. Dispatch documents of Supplies (for any 1 submitted PO of each diameter of Anchor Rod Assembly)</p> <p>III. Test certificates (for any 1 submitted PO of each diameter of Anchor Rod Assembly). Test certificate must contain following detail:</p> <ul style="list-style-type: none"> • Anchor Rod size • Material / Chemical composition • Yield Strength • Elongation • Cross-Sectional Area • Conforming Standard 	Document Enclosed: YES/NO YES/NO YES/NO																																																		

Technical Requirement:

Vendor to confirm the technical requirements as per Table-2 & 3 below:

Table-2

Sr. No.	TECHNICAL REQUIREMENTS FOR MATERIAL CODE: W97312402046	Vendor Response (YES/NO)
1	Vendor to confirm that delivery of Anchor Rod assembly shall be as per BHEL drawing (Drawing No. 31240250324) and all the technical requirements mentioned in drawing must be met in totality.	
2	Vendor to confirm delivery of Anchor Nut of Anchor Rod assembly shall be as per material & dimension mentioned in BHEL drawing (Drawing no. 31240250324).	
3	The yield strength & tensile strength of the anchor rods must be ≥ 950 N/mm ² & ≥ 1050 N/mm ² respectively.	
4	Minimum elongation at maximum force ≥ 5 %.	
5	The yield load for the dia. 36 mm threaded anchor rod (Material code: W97312402046) must be 960kN or above.	
6	The design load for the dia. 36 mm threaded anchor rod (Material code: W97312402046) must be > 908 kN.	
7	Internal thread of Hexagonal Anchor Nut & external thread of Anchor rod shall be compatible to each other throughout the length.	
8	In case of any mismatch found in technical requirement / mechanical characteristics/ properties of anchor rod between the specification ASTM A722, prEN 10138-1, prEN 10138-4 and BHEL drawing, later will prevail.	

Table-3

Sr. No.	TECHNICAL REQUIREMENTS FOR MATERIAL CODE: W97312402038	Vendor Response (YES/NO)
1	Vendor to confirm that delivery of Anchor Rod assembly shall be as per BHEL drawing (Drawing no. 31240250124) and all the technical requirements mentioned in drawings must be met in totality.	
2	Vendor to confirm delivery of Anchor Nut of Anchor Rod assembly shall be as per material & dimension mentioned in BHEL drawing (Drawing no. 31240250124).	
3	The yield strength & tensile strength of the anchor rods must be ≥ 950 N/mm ² & ≥ 1050 N/mm ² respectively.	
4	Minimum elongation at maximum force ≥ 5 %.	
5	The yield load for the dia. 32 mm threaded anchor rod (Material code: W97312402038) must be 760kN or above.	
6	The design load for the dia. 32 mm threaded anchor rod (Material code: W97312402038) must be > 705 kN.	
7	Internal thread of Hexagonal Anchor Nut & external thread of Anchor rod shall be compatible to each other throughout the length.	
8	In case of any mismatch found in technical requirement / mechanical characteristics/ properties of anchor rod between the specification ASTM A722, prEN 10138-1, prEN 10138-4 and BHEL drawing, later will prevail.	

General Notes:

- a. Against vendor's reply, BHEL reserves the right to verify /ask additional information / documents / clarifications. In case any information is found to be false / incorrect, BHEL reserves the right to reject vendor's offer.
- b. Vendor's offer shall not be considered if vendor fails to furnish the document / information / clarification as mentioned above or vendor doesn't meet the acceptance criteria (mentioned above from Sr. No. 1 to 3).
- c. All the documents and correspondences shall be accepted in English language only.
- d. BHEL team may visit Vendor works to assess vendor's manufacturing and/or testing facilities, if required.

➤ Quality Requirements-

Sl. No.	Quality Requirement	Vendor's confirmation (Y/N)
01	Testing & certification as per ordering specification, drawings and documents.	

Signature with stamp**Name:****Name of Firm:****Designation:****Date:**

ANNEXURE-III

(Drawing)

3-12402-50124
DRAWING No.

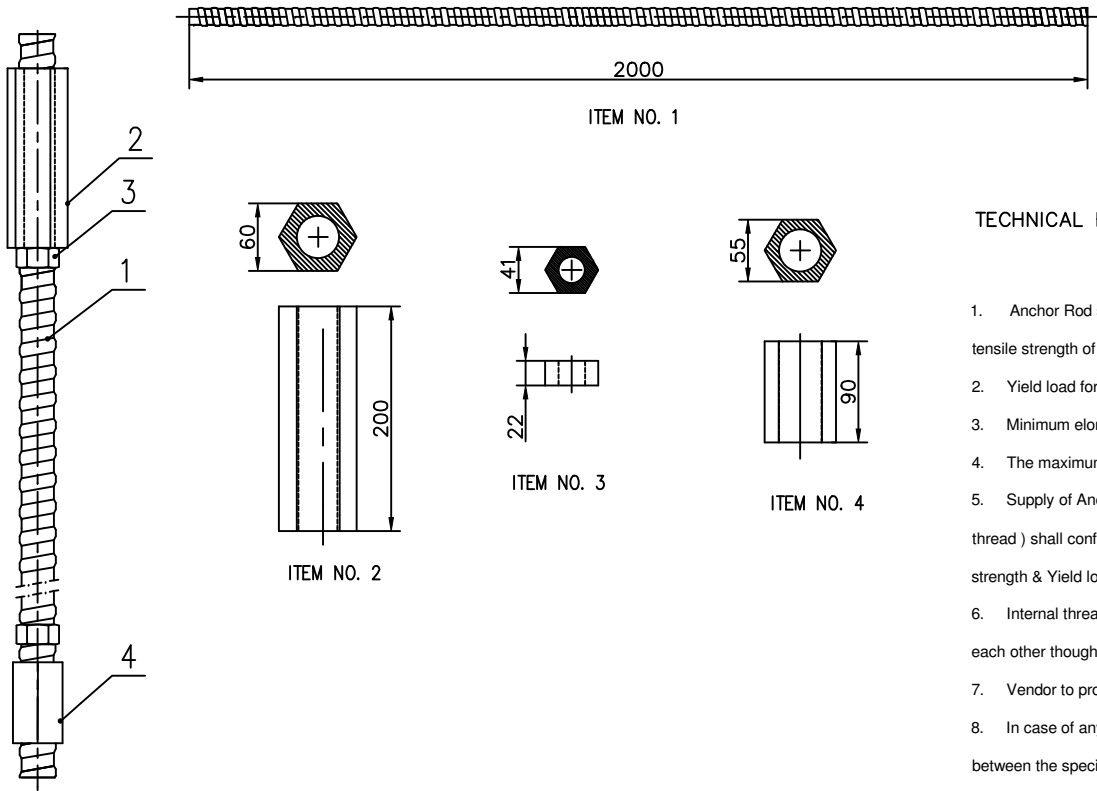

ITEM NO.	DESCRIPTION	QTY.	MATERIAL	LENGTH	WEIGHT
1.	ANCHOR ROD SAS950/1050- ϕ 32	1	St950/1050	2000	13.06 KG.
2.	HEXAGONAL COUPLER SAS-WR3009- ϕ 32	1	S355J2	200	3.37 KG
3.	FIX NUT SAS-WR-5005- ϕ 32	2	S355J2	22	0.180 KG. (M)
4.	ANCHOR NUT SAS-WR-2002- ϕ 32	1	S355J2	90	1.17 KG.
TOTAL WEIGHT					17.78 KG.

TECHNICAL REQUIREMENT: -

- Anchor Rod shall made of pre-stressing steel have a minimum yield strength of 950 N/mm² & minimum nominal tensile strength of 1050N/ mm².
- Yield load for the dia. 32 mm threaded anchor rod must be 760kN or above.
- Minimum elongation (Anchor Rod) at maximum force \geq 5 %.
- The maximum design load for the dia. 32 mm threaded anchor rod must be > 705kN.
- Supply of Anchor Rod (hot rolled and proof stressed alloy steel having uniform spaced continuous right hand coarse thread) shall conform to ASTM A722, prEN 10138-1 & prEN 10138-4 however Yield strength, nominal tensile strength & Yield load shall be as per Technical requirement 1 & 2 mentioned above.
- Internal thread of Hexagonal Anchor Nut/ coupler/ fix nut & external thread of Anchor rod shall be compatible to each other though out the length of anchor rod.
- Vendor to provide test certificate along with certificate of compliance.
- In case of any mismatch found in technical requirement / mechanical characteristics/ properties of anchor rod between the specification ASTM A722, prEN 10138-1, prEN 10138-4 and BHEL drawings requirement, later (i.e. BHEL Drawing : 3-12402-50124) will prevail.

Supplier:- STAHLWERK ANNAHUTTE MAX AICHER GmbH&Co.KG,
D-83404 HAMMERAU/GERMANY OR EQUIVALENT.

MATERIAL CODE : W97312402038.

COPYRIGHT AND CONFIDENTIAL
THE INFORMATION ON THIS DOCUMENT IS THE PROPERTY OF BHARAT HEAVY ELECTRICALS LIMITED. IT MUST NOT BE USED DIRECTLY OR INDIRECTLY IN ANY WAY DETERIMENTAL TO THE INTEREST OF THE COMPANY.

BD1033-UMA-&CLC061--600007
Sign & Date Ref.Drawing No>

Inventory No.	REV	DATE	ALTERED	MONIKA SD/-	REV	DATE	ALTERED	MONIKA SD/-	DEPT STE	SCALE	WEIGHT (KG)	REF. TO ASSY. DRG.	ITEM No.	NO. OF ITEMS							
			CHECKED	RITESH SD/-	01	31.12.19	CHECKED	RITESH SD/-													
	OR EQUIVALENT TO BE ADDED IN SUPPLIER.														ITEM NO. 3 WEIGHT CORRECTED IN TABLE		1-12402-50100		75	77	
	AS PER C/A NO. STE-21-F0054.														AS PER C/A NO. STE-19-F0339.		DRAWING NO. 3-12402-50124		22	23	24
GRADE OF UNTOL.DIM M/CG.-C/M/F AA0230208 WELDING-A/B/C/D / AA0621104 GAS CUTTING-T3'AA0621101										TYPE OF PRODUCT OR NAME OF CUSTOMER/PROJECT STEAM TURBINE		NAME MONIKA SINGH SD/- 26.02.2018 RITESH KUMAR SD/- 28.02.2018 D.K.RAY SD/- 28.02.2018		NO. OF VAR --- 73 74							
AGREED DEPT WTX NAME S.K.T SIGN SD/- DATE ---										STATUS OF DRG C B O M 0 12402 50000		BHARAT HEAVY ELECTRICALS LTD. RANIPUR, HARDWAR		CARD CODE 7		SHEET No. 01 No. OF SHEETS 01					
GMS No. / C B O M 0 12402 50000										DEPT STE CODE 4011		SCALE 1: 2.5		WEIGHT (KG) ---		REF. TO ASSY. DRG. 1-12402-50100		ITEM No. ---		NO. OF ITEMS --- 75 77	
TITLE : ANCHOR ROD ASSEMBLY										CARD CODE 7		DRAWING NO. 3-12402-50124		SHEET No. 01 No. OF SHEETS 01		NO. OF ITEMS --- 75 77					

FIRST ANGLE PROJECTION

(ALL DIMENSIONS ARE IN mm)

FORM DG 38(B)

DRAWING No. 3-12402-50324

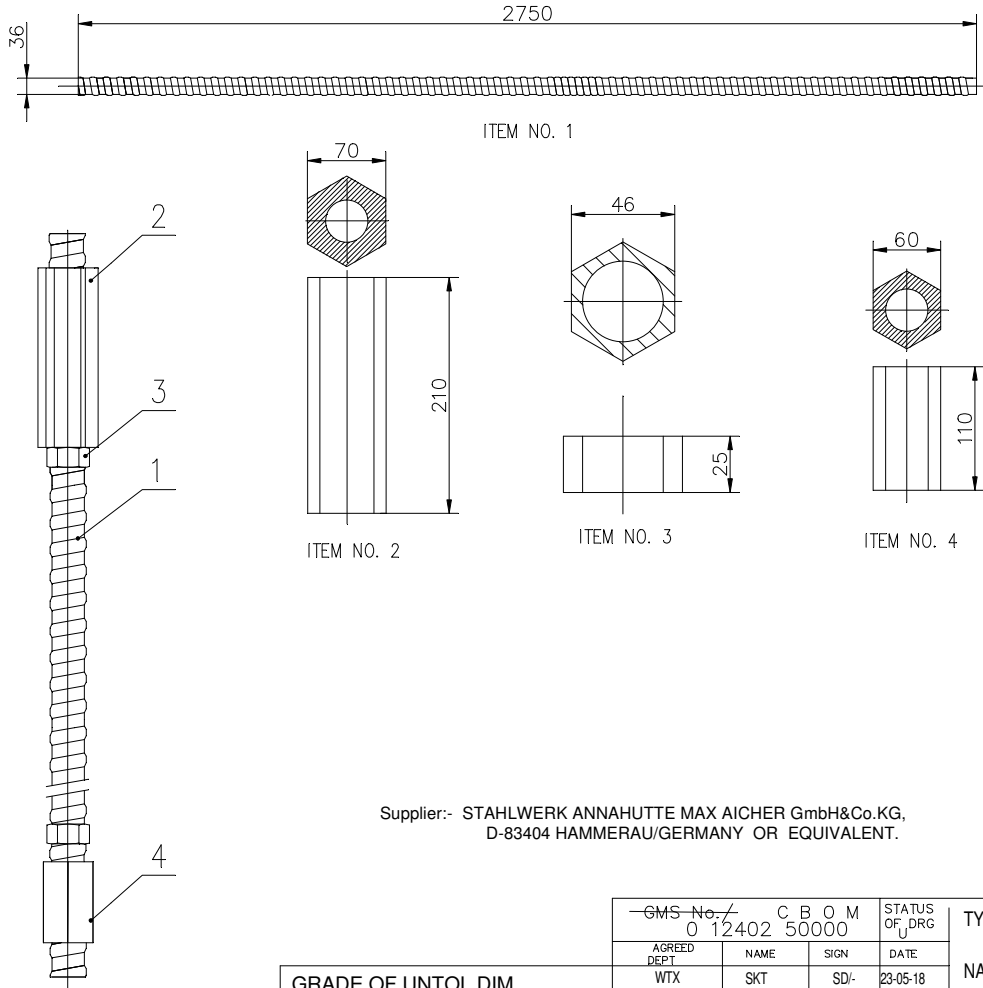

ITEM NO.	DESCRIPTION	QTY.	MATERIAL	LENGTH	WEIGHT
1.	ANCHOR ROD SAS950/1050- ϕ 36	1	St950/1050	2750	22.75 KG.
2.	HEXAGONAL COUPLER SAS-WR3009- ϕ 36	1	S355J2	210	4.46 KG
3.	FIX NUT SAS-WR-5005- ϕ 36	2	S355J2	25	0.26 KG.
4.	ANCHOR NUT SAS-WR-2002- ϕ 36	1	S355J2	110	1.63 KG.
TOTAL WEIGHT					29.1 KG.

TECHNICAL REQUIREMENT: -

- Anchor Rod shall made of pre-stressing steel have a minimum yield strength of 950 N/mm² & minimum nominal tensile strength of 1050N/ mm².
- Yield load for the diameter 36 mm threaded anchor rod must be 960kN or above.
- The maximum design load for the dia. 36 mm threaded anchor rod must be > 908kN.
- Minimum elongation of Anchor Rod at maximum force \geq 5 %
- Supply of Anchor Rod (hot rolled and proof stressed alloy steel having uniform spaced continuous right hand coarse thread) shall conform to ASTM A722, prEN 10138-1 & prEN 10138-4; however Yield strength, nominal tensile strength ,Yield load, elongation and maximum design load shall be as per Technical requirement 1 & 2 mentioned above.
- Internal thread of Hexagonal Anchor Nut/ coupler/ fix nut & external thread of Anchor rod shall compatible to each other though out the length of anchor rod.
- In case of any mismatch found in technical requirement / mechanical characteristics/ properties of anchor rod between the specification ASTM A722, prEN 10138-1, prEN 10138-4 and BHEL drawings requirement, later (i.e. BHEL Drawing : 3-12402-50324) will prevail.
- Vendor to provide test certificate along with certificate of compliance.

Supplier:- STAHLWERK ANNAHUTTE MAX AICHER GmbH&Co.KG,
D-83404 HAMMERAU/GERMANY OR EQUIVALENT.

Material Code : W97312402046.

Inventory No.	Sign & Date	REV	DATE	ALTERED CHECKED	REV 02	DATE 13.02.21	ALTERED CHECKED	MONIKA SD/- RITESH SD/-	REV 01	DATE 31.12.19	ALTERED CHECKED	MONIKA SD/- RITESH SD/-	TYPE OF PRODUCT OR NAME OF CUSTOMER/PROJECT	STEAM TURBINE				DEPT STE	SCALE 1:2.5	WEIGHT (KG) SEE TABLE	REF. TO ASSY. DRG. 1-12402-50300	ITEM No. ---	NO. OF ITEMS 75 77								
														GRADE OF UNTOL.DIM M/CG.-C/M/F AA0230208 WELDING-A/B/C/D / AA0621104 GAS CUTTING-T3'AA0621101										Bharat Heavy Electricals Ltd. RANIPUR, HARDWAR				DRAWING NO. 3-12402-50324			
OR EQUIVALENT TO BE ADDED IN SUPPLIER. AS PER C/A NO. STE-21-F0054.													ITEM NO.1 & 3 WEIGHT CORRECTED IN TABLE. AS PER C/A NO. STE-19-F0339.													CARD CODE 7		SHEET No. 01		No. OF SHEETS 01	

COPYRIGHT AND CONFIDENTIAL
THE INFORMATION ON THIS DOCUMENT IS THE PROPERTY OF BHARAT HEAVY ELECTRICALS LIMITED. IT MUST NOT BE USED DIRECTLY OR INDIRECTLY IN ANY WAY DETERIMENTAL TO THE INTEREST OF THE COMPANY.

ANNEXURE-IV
(Risk Purchase Clause)

Risk Purchase Clause

In case of abnormal delays (beyond the maximum late delivery period as per Penalty clause) in supplies / defective supplies or non-fulfilment of any other terms and conditions given in Purchase Order, BHEL may cancel the Purchase Order in full or part thereof, and may also make the purchase of such material from elsewhere / alternative source at the risk and cost of the supplier. BHEL will take all reasonable steps to get the material from alternate source at optimum cost. If bidder does not agree to the above Risk Purchase Clause, BHEL reserves the right to reject the offer. In case for compelling reasons BHEL accepts the offer without acceptance of this clause by the bidder and in the eventuality of Risk Purchase, appropriate action will be taken as per BHEL extant rules. This will be without prejudice to any other right of BHEL under the contract.

Risk & Cost Clause, in line with Conditions of Contract may be invoked in any of the following cases:

1. Contractor/ supplier's poor progress of the work vis-à-vis execution timeline as stipulated in the Contract, backlog attributable to contractor/ supplier including unexecuted portion of work/ supply does not appear to be executable within balance available period (#) considering its performance of execution.
2. Withdrawal from or abandonment of the work by contractor before completion of the work as per contract.
3. Non completion of work/ Non-supply by the Contractor/ supplier within scheduled completion/delivery period as per Contract or as extended from time to time, for the reason attributable to the contractor/ supplier.
4. Termination of Contract on account of any other reason (s) attributable to Contractor/ Supplier.
5. Assignment, transfer, subletting of Contract without BHEL's written permission resulting in termination of Contract or part thereof by BHEL.
6. Non-compliance to any contractual condition or any other default attributable to Contractor/ Supplier.

#In-case inputs from BHEL/Customer are likely to be delayed or are actually delayed, this delay may also be taken into account while considering balance period available for execution of Contract.

Risk and Cost against Balance Work:

Risk & Cost Amount= $[(A-B) + (A \times H/100)]$

Where,

A= Value of Balance scope of Work/ Supply (*) as per rates of new contract

B= Value of Balance scope of Work/ Supply (*) as per rates of old contract being paid to the contractor/ supplier at the time of termination of contract i.e. inclusive of PVC & ORC, if any.

H = Overhead Factor to be taken as 5

In case (A-B) is less than 0 (zero), value of (A-B) shall be taken as 0 (zero).

***(Balance scope of work/ supply)**

Difference of Contract Quantities and Executed Quantities as on the date of issue of Letter for 'Termination of Contract', shall be taken as balance scope of Work/ Supply for calculating risk & cost amount.

Contract quantities are the quantities as per original contract. If, Contract has been amended, quantities as per amended Contract shall be considered as Contract Quantities.

Items for which total quantities to be executed have exceeded the Contract Quantities based on drawings issued to contractor from time to time till issue of Termination letter, then for these items total Quantities as per issued drawings would be deemed to be contract quantities.

Substitute/ extra items whose rates have already been approved would form part of contract quantities for this purpose. Substitute/ extra items which have been executed but rates have not been approved, would also form part of contract quantities for this purpose and rates of such items shall be determined in line with contractual provisions.

However, increase in quantities on account of additional scope in new tender shall not be considered for this purpose.

NOTE: In case portion of work is being withdrawn, contract quantities pertaining to portion of work withdrawn shall be considered as 'Balance scope of work/supply' for calculating Risk & Cost amount.

LD against delay in executed work/supply in case of Termination of Contract

LD against delay in executed work/supply shall be calculated in line with LD clause of the contract for the delay attributable to contractor/ supplier. For this purpose, contract value shall be taken as Executed Value of work/supply for the purpose of limiting maximum LD value.

Method for calculation of "LD against delay in executed work/supply" is given below.

- i. Let the time period from scheduled date of start of work till termination of contract excluding the period of Hold (if any) not attributable to contractor/ supplier= T1
- ii. Let the value of executed work/supply till the time of termination of contract= X
- iii. Let the Total Executable Value of work/supply for which inputs/fronTS were made available to contractor/ supplier and were planned for execution till termination of contract = Y
- iv. Delay in executed work/supply attributable to contractor/supplier i.e.
$$T2 = \frac{(1-X)}{Y} \times T1$$
- v. LD shall be calculated in line with LD clause of the Contract for the delay attributable to contractor/ supplier taking "X" as Contract Value and "T2" as delay attributable to contractor/ supplier.

Note: In case portion of work/supply is withdrawn, no LD shall be applicable for portion of work/supply withdrawn.

ANNEXURE- V

Certificate by Chartered Accountant on letter head

This is to Certify that M/s
(hereinafter referred to as 'company') having its registered office atis
registered under MSMED Act 2006, (Entrepreneur Memorandum No (Part- II)
.....dtd:.....,
Category:.....(Micro/Small).(copy enclosed).

Further verified from the Books of Accounts that the investment of the company as
on dateas per MSMED Act 2006 is as follows:

1. **For Manufacturing Enterprises:** Investment in plant and machinery (i.e. original cost excluding land and building and the items specified by the Ministry of Small Scale Industries vide its notification No. S.O.1722(E) dated October 5, 2006:
Rs.....Lacs
2. **For Service Enterprises:** Investment in equipment (original cost excluding land and building and furniture, fittings and other items not directly related to the service rendered or as may be notified under the MSMED act, 2006:
Rs.....Lacs

(Strike off whichever is not applicable)

The above investment of RsLacs is within permissible limit of Rs..... Lacs for
.....micro / small (Strike off which is not applicable) Category under MSMED Act 2006.

Or

The company has been graduated from its original category (Micro / Small) (**Strike off whichever is not applicable**) and the date of graduation of such enterprises from its original category is
(dd/mm/yyyy) which is within the period of 3 years from the date of graduation of such enterprises from its original category as notified vide S.O. No. 3322(E) dated 01.11.2013 published in the gazette notification dated 04.11.2013 by Ministry of MSME.

Date:

(Signature)

Name-

Membership Number-

Seal of Chartered Accountant

ANNEXURE-VI
(Order 2017 dated 16.09.2020)

No. P-45021/2/2017-PP (BE-II)
Government of India
Ministry of Commerce and Industry
Department for Promotion of Industry and Internal Trade
(Public Procurement Section)

Udyog Bhawan, New Delhi
Dated: 16th September, 2020

To

All Central Ministries/Departments/CPSUs/All concerned

ORDER

Subject: Public Procurement (Preference to Make in India), Order 2017– Revision; regarding.

Department for Promotion of Industry and Internal Trade, in partial modification [Paras 2, 3, 5, 10 & 13] of Order No.P-45021/2/2017-B.E.-II dated 15.6.2017 as amended by Order No.P-45021/2/2017-B.E.-II dated 28.05.2018, Order No.P-45021/2/2017-B.E.-II dated 29.05.2019 and Order No.P-45021/2/2017-B.E.-II dated 04.06.2020, hereby issues the revised 'Public Procurement (Preference to Make in India), Order 2017' dated 16.09.2020 effective with immediate effect.

Whereas it is the policy of the Government of India to encourage 'Make in India' and promote manufacturing and production of goods and services in India with a view to enhancing income and employment, and

Whereas procurement by the Government is substantial in amount and can contribute towards this policy objective, and

Whereas local content can be increased through partnerships, cooperation with local companies, establishing production units in India or Joint Ventures (JV) with Indian suppliers, increasing the participation of local employees in services and training them,

Now therefore the following Order is issued:

1. This Order is issued pursuant to Rule 153 (iii) of the General Financial Rules 2017.
2. **Definitions:** For the purposes of this Order:

'Local content' means the amount of value added in India which shall, unless otherwise prescribed by the Nodal Ministry, be the total value of the item procured (excluding net domestic indirect taxes) minus the value of imported content in the item (including all customs duties) as a proportion of the total value, in percent.

'Class-I local supplier' means a supplier or service provider, whose goods, services or works offered for procurement, meets the minimum local content as prescribed for 'Class-I local supplier' under this Order.

.....Contd. p/2

'Class-II local supplier' means a supplier or service provider, whose goods, services or works offered for procurement, meets the minimum local content as prescribed for 'Class-II local supplier' but less than that prescribed for 'Class-I local supplier' under this Order.

'Non - Local supplier' means a supplier or service provider, whose goods, services or works offered for procurement, has local content less than that prescribed for 'Class-II local supplier' under this Order.

'L1' means the lowest tender or lowest bid or the lowest quotation received in a tender, bidding process or other procurement solicitation as adjudged in the evaluation process as per the tender or other procurement solicitation.

'Margin of purchase preference' means the maximum extent to which the price quoted by a "Class-I local supplier" may be above the L1 for the purpose of purchase preference.

'Nodal Ministry' means the Ministry or Department identified pursuant to this order in respect of a particular item of goods or services or works.

'Procuring entity' means a Ministry or department or attached or subordinate office of, or autonomous body controlled by, the Government of India and includes Government companies as defined in the Companies Act.

'Works' means all works as per Rule 130 of GFR- 2017, and will also include 'turnkey works'.

3. Eligibility of 'Class-I local supplier' / 'Class-II local supplier' / 'Non-local suppliers' for different types of procurement

(a) In procurement of all goods, services or works in respect of which the Nodal Ministry / Department has communicated that there is sufficient local capacity and local competition, only 'Class-I local supplier', as defined under the Order, shall be eligible to bid irrespective of purchase value.

(b) Only 'Class-I local supplier' and 'Class-II local supplier', as defined under the Order, shall be eligible to bid in procurements undertaken by procuring entities, except when Global tender enquiry has been issued. In global tender enquiries, 'Non-local suppliers' shall also be eligible to bid along with 'Class-I local suppliers' and 'Class-II local suppliers'. In procurement of all goods, services or works, not covered by sub-para 3(a) above, and with estimated value of purchases less than Rs. 200 Crore, in accordance with Rule 161(iv) of GFR, 2017, Global tender enquiry shall not be issued except with the approval of competent authority as designated by Department of Expenditure.

(c) For the purpose of this Order, works includes Engineering, Procurement and Construction (EPC) contracts and services include System Integrator (SI) contracts.

.....Contd. p/3

3A. Purchase Preference

(a) Subject to the provisions of this Order and to any specific instructions issued by the Nodal Ministry or in pursuance of this Order, purchase preference shall be given to 'Class-I local supplier' in procurements undertaken by procuring entities in the manner specified here under.

(b) In the procurements of goods or works, which are covered by para 3(b) above and which are divisible in nature, the 'Class-I local supplier' shall get purchase preference over 'Class-II local supplier' as well as 'Non-local supplier', as per following procedure:

- i. Among all qualified bids, the lowest bid will be termed as L1. If L1 is 'Class-I local supplier', the contract for full quantity will be awarded to L1.
- ii. If L1 bid is not a 'Class-I local supplier', 50% of the order quantity shall be awarded to L1. Thereafter, the lowest bidder among the 'Class-I local supplier' will be invited to match the L1 price for the remaining 50% quantity subject to the Class-I local supplier's quoted price falling within the margin of purchase preference, and contract for that quantity shall be awarded to such 'Class-I local supplier' subject to matching the L1 price. In case such lowest eligible 'Class-I local supplier' fails to match the L1 price or accepts less than the offered quantity, the next higher 'Class-I local supplier' within the margin of purchase preference shall be invited to match the L1 price for remaining quantity and so on, and contract shall be awarded accordingly. In case some quantity is still left uncovered on Class-I local suppliers, then such balance quantity may also be ordered on the L1 bidder.

(c) In the procurements of goods or works, which are covered by para 3(b) above and which are not divisible in nature, and in procurement of services where the bid is evaluated on price alone, the 'Class-I local supplier' shall get purchase preference over 'Class-II local supplier' as well as 'Non-local supplier', as per following procedure:

- i. Among all qualified bids, the lowest bid will be termed as L1. If L1 is 'Class-I local supplier', the contract will be awarded to L1.
- ii. If L1 is not 'Class-I local supplier', the lowest bidder among the 'Class-I local supplier', will be invited to match the L1 price subject to Class-I local supplier's quoted price falling within the margin of purchase preference, and the contract shall be awarded to such 'Class-I local supplier' subject to matching the L1 price.
- iii. In case such lowest eligible 'Class-I local supplier' fails to match the L1 price, the 'Class-I local supplier' with the next higher bid within the margin of purchase preference shall be invited to match the L1 price and so on and contract shall be awarded accordingly. In case none of the 'Class-I local supplier' within the margin of purchase preference matches the L1 price, the contract may be awarded to the L1 bidder.

- (d) "Class-II local supplier" will not get purchase preference in any procurement, undertaken by procuring entities.

3B. Applicability in tenders where contract is to be awarded to multiple bidders -

In tenders where contract is awarded to multiple bidders subject to matching of L1 rates or otherwise, the 'Class-I local supplier' shall get purchase preference over 'Class-II local supplier' as well as 'Non-local supplier', as per following procedure:

- a) In case there is sufficient local capacity and competition for the item to be procured, as notified by the nodal Ministry, only Class I local suppliers shall be eligible to bid. As such, the multiple suppliers, who would be awarded the contract, should be all and only 'Class I Local suppliers'.
- b) In other cases, 'Class II local suppliers' and 'Non local suppliers' may also participate in the bidding process along with 'Class I Local suppliers' as per provisions of this Order.
- c) If 'Class I Local suppliers' qualify for award of contract for at least 50% of the tendered quantity in any tender, the contract may be awarded to all the qualified bidders as per award criteria stipulated in the bid documents. However, in case 'Class I Local suppliers' do not qualify for award of contract for at least 50% of the tendered quantity, purchase preference should be given to the 'Class I local supplier' over 'Class II local suppliers'/'Non local suppliers' provided that their quoted rate falls within 20% margin of purchase preference of the highest quoted bidder considered for award of contract so as to ensure that the 'Class I Local suppliers' taken in totality are considered for award of contract for at least 50% of the tendered quantity.
- d) First purchase preference has to be given to the lowest quoting 'Class-I local supplier', whose quoted rates fall within 20% margin of purchase preference, subject to its meeting the prescribed criteria for award of contract as also the constraint of maximum quantity that can be sourced from any single supplier. If the lowest quoting 'Class-I local supplier', does not qualify for purchase preference because of aforesaid constraints or does not accept the offered quantity, an opportunity may be given to next higher 'Class-I local supplier', falling within 20% margin of purchase preference, and so on.
- e) To avoid any ambiguity during bid evaluation process, the procuring entities may stipulate its own tender specific criteria for award of contract amongst different bidders including the procedure for purchase preference to 'Class-I local supplier' within the broad policy guidelines stipulated in sub-paras above.

4. **Exemption of small purchases:** Notwithstanding anything contained in paragraph 3, procurements where the estimated value to be procured is less than Rs. 5 lakhs shall be exempt from this Order. However, it shall be ensured by procuring entities that procurement is not split for the purpose of avoiding the provisions of this Order.

5. **Minimum local content:** The 'local content' requirement to categorize a supplier as 'Class-I local supplier' is minimum 50%. For 'Class-II local supplier', the 'local content' requirement is minimum 20%. Nodal Ministry/ Department may prescribe only a higher

percentage of minimum local content requirement to categorize a supplier as 'Class-I local supplier'/ 'Class-II local supplier'. For the items, for which Nodal Ministry/ Department has not prescribed higher minimum local content notification under the Order, it shall be 50% and 20% for 'Class-I local supplier'/ 'Class-II local supplier' respectively.

6. **Margin of Purchase Preference:** The margin of purchase preference shall be 20%.
7. **Requirement for specification in advance:** The minimum local content, the margin of purchase preference and the procedure for preference to Make in India shall be specified in the notice inviting tenders or other form of procurement solicitation and shall not be varied during a particular procurement transaction.
8. **Government E-marketplace:** In respect of procurement through the Government E-marketplace (GeM) shall, as far as possible, specifically mark the items which meet the minimum local content while registering the item for display, and shall, wherever feasible, make provision for automated comparison with purchase preference and without purchase preference and for obtaining consent of the local supplier in those cases where purchase preference is to be exercised.
9. **Verification of local content:**
 - a. The 'Class-I local supplier'/ 'Class-II local supplier' at the time of tender, bidding or solicitation shall be required to indicate percentage of local content and provide self-certification that the item offered meets the local content requirement for 'Class-I local supplier'/ 'Class-II local supplier', as the case may be. They shall also give details of the location(s) at which the local value addition is made.
 - b. In cases of procurement for a value in excess of Rs. 10 crores, the 'Class-I local supplier'/ 'Class-II local supplier' shall be required to provide a certificate from the statutory auditor or cost auditor of the company (in the case of companies) or from a practicing cost accountant or practicing chartered accountant (in respect of suppliers other than companies) giving the percentage of local content.
 - c. Decisions on complaints relating to implementation of this Order shall be taken by the competent authority which is empowered to look into procurement-related complaints relating to the procuring entity.
 - d. Nodal Ministries may constitute committees with internal and external experts for independent verification of self-declarations and auditor's/ accountant's certificates on random basis and in the case of complaints.
 - e. Nodal Ministries and procuring entities may prescribe fees for such complaints.
 - f. False declarations will be in breach of the Code of Integrity under Rule 175(1)(i)(h) of the General Financial Rules for which a bidder or its successors can be debarred for up to two years as per Rule 151 (iii) of the General Financial Rules along with such other actions as may be permissible under law.

- g. A supplier who has been debarred by any procuring entity for violation of this Order shall not be eligible for preference under this Order for procurement by any other procuring entity for the duration of the debarment. The debarment for such other procuring entities shall take effect prospectively from the date on which it comes to the notice of other procurement entities, in the manner prescribed under paragraph 9h below.
- h. The Department of Expenditure shall issue suitable instructions for the effective and smooth operation of this process, so that:
 - i. The fact and duration of debarment for violation of this Order by any procuring entity are promptly brought to the notice of the Member-Convenor of the Standing Committee and the Department of Expenditure through the concerned Ministry /Department or in some other manner;
 - ii. on a periodical basis such cases are consolidated and a centralized list or decentralized lists of such suppliers with the period of debarment is maintained and displayed on website(s);
 - iii. in respect of procuring entities other than the one which has carried out the debarment, the debarment takes effect prospectively from the date of uploading on the website(s) in the such a manner that ongoing procurements are not disrupted.

10. Specifications in Tenders and other procurement solicitations:

- a. Every procuring entity shall ensure that the eligibility conditions in respect of previous experience fixed in any tender or solicitation do not require proof of supply in other countries or proof of exports.
- b. Procuring entities shall endeavour to see that eligibility conditions, including on matters like turnover, production capability and financial strength do not result in unreasonable exclusion of 'Class-I local supplier'/ 'Class-II local supplier' who would otherwise be eligible, beyond what is essential for ensuring quality or creditworthiness of the supplier.
- c. Procuring entities shall, within 2 months of the issue of this Order review all existing eligibility norms and conditions with reference to sub-paragraphs 'a' and 'b' above.

d. Reciprocity Clause

- i. When a Nodal Ministry/Department identifies that Indian suppliers of an item are not allowed to participate and/ or compete in procurement by any foreign government, due to restrictive tender conditions which have direct or indirect effect of barring Indian companies such as registration in the procuring country, execution of projects of specific value in the procuring country etc., it shall provide such details to all its procuring entities including CMDs/CEOs of PSEs/PSUs, State Governments and other procurement agencies under their administrative control and GeM for appropriate reciprocal action.

- ii. Entities of countries which have been identified by the nodal Ministry/Department as not allowing Indian companies to participate in their Government procurement for any item related to that nodal Ministry shall not be allowed to participate in Government procurement in India for all items related to that nodal Ministry/ Department, except for the list of items published by the Ministry/ Department permitting their participation.
 - iii. The stipulation in (ii) above shall be part of all tenders invited by the Central Government procuring entities stated in (i) above. All purchases on GeM shall also necessarily have the above provisions for items identified by nodal Ministry/ Department.
 - iv. State Governments should be encouraged to incorporate similar provisions in their respective tenders.
 - v. The term 'entity' of a country shall have the same meaning as under the FDI Policy of DPIIT as amended from time to time.
- e. Specifying foreign certifications/ unreasonable technical specifications/ brands/ models in the bid document is restrictive and discriminatory practice against local suppliers. If foreign certification is required to be stipulated because of non-availability of Indian Standards and/or for any other reason, the same shall be done only after written approval of Secretary of the Department concerned or any other Authority having been designated such power by the Secretary of the Department concerned.
- f. "All administrative Ministries/Departments whose procurement exceeds Rs. 1000 Crore per annum shall notify/ update their procurement projections every year, including those of the PSEs/PSUs, for the next 5 years on their respective website."

10A. Action for non-compliance of the Provisions of the Order: In case restrictive or discriminatory conditions against domestic suppliers are included in bid documents, an inquiry shall be conducted by the Administrative Department undertaking the procurement (including procurement by any entity under its administrative control) to fix responsibility for the same. Thereafter, appropriate action, administrative or otherwise, shall be taken against erring officials of procurement entities under relevant provisions. Intimation on all such actions shall be sent to the Standing Committee.

11. Assessment of supply base by Nodal Ministries: The Nodal Ministry shall keep in view the domestic manufacturing / supply base and assess the available capacity and the extent of local competition while identifying items and prescribing the higher minimum local content or the manner of its calculation, with a view to avoiding cost increase from the operation of this Order.

12. Increase in minimum local content: The Nodal Ministry may annually review the local content requirements with a view to increasing them, subject to availability of sufficient local competition with adequate quality.

13. **Manufacture under license/ technology collaboration agreements with phased indigenization:** While notifying the minimum local content, Nodal Ministries may make special provisions for exempting suppliers from meeting the stipulated local content if the product is being manufactured in India under a license from a foreign manufacturer who holds intellectual property rights and where there is a technology collaboration agreement / transfer of technology agreement for indigenous manufacture of a product developed abroad with clear phasing of increase in local content.

13A. In procurement of all goods, services or works in respect of which there is substantial quantity of public procurement and for which the nodal ministry has not notified that there is sufficient local capacity and local competition, the concerned nodal ministry shall notify an upper threshold value of procurement beyond which foreign companies shall enter into a joint venture with an Indian company to participate in the tender. Procuring entities, while procuring such items beyond the notified threshold value, shall prescribe in their respective tenders that foreign companies may enter into a joint venture with an Indian company to participate in the tender. The procuring Ministries/Departments shall also make special provisions for exempting such joint ventures from meeting the stipulated minimum local content requirement, which shall be increased in a phased manner.

14. **Powers to grant exemption and to reduce minimum local content:** The administrative Department undertaking the procurement (including procurement by any entity under its administrative control), with the approval of their Minister-in-charge, may by written order, for reasons to be recorded in writing,

- a. reduce the minimum local content below the prescribed level; or
- b. reduce the margin of purchase preference below 20%; or
- c. exempt any particular item or supplying entities from the operation of this Order or any part of the Order.

A copy of every such order shall be provided to the Standing Committee and concerned Nodal Ministry / Department. The Nodal Ministry / Department concerned will continue to have the power to vary its notification on Minimum Local Content.

15. **Directions to Government companies:** In respect of Government companies and other procuring entities not governed by the General Financial Rules, the administrative Ministry or Department shall issue policy directions requiring compliance with this Order.

16. **Standing Committee:** A standing committee is hereby constituted with the following membership:

Secretary, Department for Promotion of Industry and Internal Trade—Chairman
Secretary, Commerce—Member
Secretary, Ministry of Electronics and Information Technology—Member
Joint Secretary (Public Procurement), Department of Expenditure—Member
Joint Secretary (DPIIT)—Member-Convenor

The Secretary of the Department concerned with a particular item shall be a member in respect of issues relating to such item. The Chairman of the Committee may co-opt technical experts as relevant to any issue or class of issues under its consideration.

17. Functions of the Standing Committee: The Standing Committee shall meet as often as necessary, but not less than once in six months. The Committee

- a. shall oversee the implementation of this order and issues arising therefrom, and make recommendations to Nodal Ministries and procuring entities.
- b. shall annually assess and periodically monitor compliance with this Order
- c. shall identify Nodal Ministries and the allocation of items among them for issue of notifications on minimum local content
- d. may require furnishing of details or returns regarding compliance with this Order and related matters
- e. may, during the annual review or otherwise, assess issues, if any, where it is felt that the manner of implementation of the order results in any restrictive practices, cartelization or increase in public expenditure and suggest remedial measures
- f. may examine cases covered by paragraph 13 above relating to manufacture under license/ technology transfer agreements with a view to satisfying itself that adequate mechanisms exist for enforcement of such agreements and for attaining the underlying objective of progressive indigenization
- g. may consider any other issue relating to this Order which may arise.

18. Removal of difficulties: Ministries /Departments and the Boards of Directors of Government companies may issue such clarifications and instructions as may be necessary for the removal of any difficulties arising in the implementation of this Order.

19. Ministries having existing policies: Where any Ministry or Department has its own policy for preference to local content approved by the Cabinet after 1st January 2015, such policies will prevail over the provisions of this Order. All other existing orders on preference to local content shall be reviewed by the Nodal Ministries and revised as needed to conform to this Order, within two months of the issue of this Order.

20. Transitional provision: This Order shall not apply to any tender or procurement for which notice inviting tender or other form of procurement solicitation has been issued before the issue of this Order.

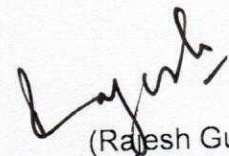

(Rajesh Gupta)
Director

Tel: 23063211

rajesh.gupta66@gov.in

ANNEXURE-VII

(Self-Certification for local content)

In line with Government Public Procurement Order 2017 dated 16.09.2020, we hereby certify that we

.....
(supplier name) inform that local content is% (indicate percentage of local content) and are

Class- I local supplier (meeting requirement of)-

Minimum Local content 50%

OR

Class- II local supplier (meeting requirement of)-

Minimum Local content 20%

(mark wherever applicable)

defined by Nodal Ministries/ Departments as per above order for the material against Enquiry No.

.....
Details of location at which local value addition will be made is as follows:

.....
.....
.....

We also understand, false declarations will be in breach of the Code of Integrity under Rule 175(1)(i)(h) of the General Financial Rules for which a bidder or its successors can be debarred for up to two years as per Rule 151 (iii) of the General Financial Rules along with such other actions as may be permissible under law.

Seal and Signature of Supplier