



**NOTICE INVITING TENDER**

Ref.: OS/26-27/CS DE/12/012

Date: 09.06.2026

**Sub: Forming of CS Dished Ends against SO Nos. 8117, 8136, 8158, 8159, 8160, 8170, 8194, 8195, 8207 & 8208 at vendor works with free issue materials**

Dear Sir,

Sealed tenders are invited for the subject work in **Two-part bid** system from the vendors who are experienced in execution of similar jobs subject to the following **eligibility criteria**:

- (1) Bidders must have an experience in execution of similar jobs during the past 7 Years as on **31.05.2026**. Bidders shall enclose Work Orders, Work Completion Certificates and all other relevant documents in support of their experience in execution of similar job for at least one project. The works executed in own name of the individual / firm of the tenderer will only be considered for eligibility criteria.
- (2) Bidders shall have to enclose the documents of PAN, GSTIN, Udyam Registration Certificate (if registered with MSME) etc.
- (3) Any Bidder falling under MSE category shall furnish the following details & submit documentary evidence/ Govt. Certificate etc., in support of the same along with their Techno-commercial offer.

Type under MSE	SC/ST Owned	Women Owned	Others (excluding SC/ST & Women Owned)
Micro			
Small			

**Note:** Tick (✓) mark in the applicable box and mention "NA" wherever not applicable.

If the bidder does not furnish the above in the tender, offer shall be processed construing that the bidder is not falling under MSE category.

**1. VENDOR'S SCOPE OF WORK:**

- a) Forming of Carbon Steel Dished Ends (2:1 Ellipsoidal & Tori spherical Dished ends) for various projects as detailed in Annexure-II with free issue Cut-to-size blanks as per applicable Drawings, QAP/SQP, Specifications, Standards, Procedures etc.
- b) Collection of Cut to Size blank plates along with Production Test Coupons (PTC) from Production Shops at HPVP-Visakhapatnam.
- c) Transportation of (i) Cut to Size Blank plates from BHEL-HPVP, Visakhapatnam to Vendor works and (ii) Formed Dished Ends along with Templates from vendor works to BHEL-HPVP, Visakhapatnam including transit insurance and delivery at BHEL-HPVP Production shops, Visakhapatnam. Unloading of Cut-to-size blanks at vendor's works. Transportation will be in lots - 2 trips maximum from one side.
- d) **For SOQ item nos. 1, 2, 3 & 5:** Cut-to-Size blanks in 1 piece per Dished end and  
**For SOQ item nos. 4 & 6:** Cut-to-Size blanks in 2 pieces per Dished end shall be issued along with PTC with Edge Preparation by BHEL-HPVP.
- e) For SOQ item nos. 4 & 6 only: Fit-up, Welding, BG, Grinding, DPT, RT of Weld Joint in between the two pieces of Cut-to-Size blanks for formation of circular Blank for each Dished end as per approved drawings and QAP/SQP is in vendor's scope. PTC have no optional joint.
- f) Welding shall be carried out with qualified welders as per approved WPS provided by BHEL-HPVP followed by required NDT as per approved QAP/SQP.
- g) Dimensions, ID & Thickness of formed dished ends shall be strictly within the tolerances given in the drawings, QAP / SQP. Vendor has to ensure specified minimum thickness after forming through out the surface of the dished ends including Knuckle portion.

- h) Normalizing of formed Dished ends shall be carried out as per respective drawings, Standards & QAP/SQP. Normalizing Charts duly certified by the inspection agency shall be submitted to BHEL/TPIA along with the inspection reports for clearance for further operations.
- i) After welding of PTC, Dished end mechanical properties shall be proved on the test coupons, after the Test coupon is subjected to same heat treatment as the dished ends including the final normalization (only for blanks with chordal Joints). Testing charges are in vendor's scope.
- j) 100% radiography is to be carried out for the butt weld joint after forming. In case of any repairs, the rectification of the repair is to be carried out with qualified welders as per approved procedures followed by required NDT as per approved QAP/SQP.
- k) Both inside and outside surface of weld seam shall be MT examined after normalization as per approved QAP/SQP.
- l) DPT shall be carried out on both sides of the knuckle area & weld joints and UT shall be carried out on entire surface of dished ends after forming as per approved QAP/SQP.
- m) In case of spinning method of forming, central hole is to be plugged and radiography is to be carried out. Welding is to be carried out by qualified welders as per approved WPS.
- n) All consumables like Electrodes & Filler wires, Gases, Grinding wheels etc., required for Welding are in the scope of the Vendor. The electrodes / filler wire shall be of BHEL approved makes only and the vendor shall submit the Batch Test Certificates to BHEL for verification before using on the job.
- o) **For SOQ item no. 4:** WPS No. M.1.1.85, R02 and **For SOQ item no. 6:** WPS No. M.1.1.02, R02 are to be followed.
- p) Material identification no. is to be maintained by Dished End manufacturer before, during & after forming operation.
- q) Dished ends shall be protected against corrosion by a temporary coat of rust preventive.
- r) All NDT requirements like PT, UT, RT etc., shall be carried out as per applicable drawings, approved QAP, Standards & procedures.
- s) Ovality at any cross section shall not exceed 0.5% of the nominal diameter and actual ovality readings at the SF end are to be mentioned in the dimensional report.
- t) Template used for checking the profile to be sent along with dished end by the vendor.
- u) The Straightness of SF is to be ensured and the same is to be reported in the dimensional report. Tolerance of SF length is + 10/-0 mm.
- v) The ID Dimension to be measured at SF and the same is to be reported in the dimensional report.
- w) Dished end inner height tolerance (excluding SF): = + 0.625% of ID / - 0.3125% of ID and the same to be reported in the dimensional report.
- x) HT report & graph, NDE reports and dimensional reports duly certified by the inspection agencies are to be sent along with the Dished end by the vendor.
- y) Though not mentioned specifically, any activity which is required for completion of the work is deemed to be included in the scope of bidders without any price implication.

**2. LOCATION OF WORK SPOT:**

Forming of Dished ends shall be carried out at **Vendor's Works.**

**3. BHEL SCOPE:**

- a) Issue of Drawings, WPS, Approved QAP/ SQP, Product Standard etc.
- b) Issue of Cut-to-Size blanks in i) 2 pieces per Dished end for SOQ item nos. 4 & 6, ii) one piece per Dished end for SOQ item nos. 1, 2, 3 & 5 and PTC with Edge Preparation
- c) Unloading of Formed Dished ends at BHEL-HPVP, Visakhapatnam
- d) Height & TL Marking, cutting of extra height and Edge Preparation of formed Dished ends as per drawings

**4. INSPECTION:**

- a) Inspection shall be carried out at Vendor's works by M/s. BHEL / BHEL Authorized Inspection Agency and as per approved QAP / SQP.
- b) The drawings and QAP / SQP enclosed with the tender are indicative and for tendering purpose only. The approved QAP / SQP & drawings issued to the vendor after ordering shall only be followed for execution and inspection of the job.
- c) Dished End supplier shall furnish Inspection Reports for a) Method of Forming, b) Intermediate Heat Treatment, if any carried out, c) Dimensional Report including minimum thickness, ovality readings at the SF end, Straightness of SF, ID Dimension at SF etc., d) NDE Reports, e) Results of Template check etc., to BHEL as per approved QAP.
- d) All the documentation related to inspection clearance of BHEL / TPIA / Customer, Generation of Inspection Reports, Preparation of Final Documents etc., as per BHEL standard formats is included in the scope of vendor and submission of soft copy as well as hard copy of the same to BHEL-QA.

**5. DELIVERY:**

- a) The delivery period shall be **within 8 weeks from the date of intimation of readiness of blank plates** at BHEL-HPVP shops, Visakhapatnam.
- b) The delivery period will be calculated from the date of intimation of readiness of blank plates at BHEL-HPVP, Visakhapatnam to the date of delivery of finished Dished Ends at BHEL-HPVP, Visakhapatnam.
- c) In case the delivery period offered by the vendor is more than the tender delivery, Loading for additional delivery period shall be @ 0.5% per week or part thereof on the price quoted by the vendor for the purpose of evaluation of L1 status.

**6. PRICE:**

- a) The price shall be quoted in the **Price Bid** as per the Schedule of Quantities & Rates for the detailed scope of work and the quoted price shall be inclusive of all applicable taxes & duties except GST.
- b) Bidder has to quote for all the items. **Part quotation is not acceptable and liable for rejection.**
- c) The prices shall be fixed & firm without any escalation during the entire period of contract and till completion of the work.
- d) Income tax shall be deducted at applicable rates from the vendor's bills. GST shall be reimbursable to the vendor as per applicable guidelines.

**7. VALIDITY OF OFFER:**

The offer shall be valid for a period of **3 months** from the date of Reverse Auction.

**8. GOODS & SERVICES TAX (GST):**

**Bidders shall make a note of the following points of GST before submission of their offer: -**

- a) Vendors shall have to mention their GSTIN no. (15 Digits) in their Technical Bid. If any specific exemption is available, a declaration with due supporting documents need to be furnished for considering their offer.
- b) Semi-finished goods are to be delivered by the Vendors in BHEL, HPVP premises within a maximum period of one year from the date of issue of the material, failing which the whole transaction will be considered as Supply and Sale and GST is required to be paid along with interest (calculated @ SBI Base Rate + 6%) along with penalty, if any, from the date of Challan on the whole value of materials. Hence vendors shall have to ensure that materials issued to them are returned within 365 days.
- c) After fabrication, the vendors shall have to deliver the Semi-Finished Goods by fulfilling the following formalities: -
  - i) GST invoice should be raised by the vendors by paying GST on job work charges at applicable rates and by incorporating the HPVP GSTIN no. in the invoice for availing the reimbursement of GST from HPVP.
  - ii) The vendor shall also have to enter in their GST Return -1 (GSTR-1) the details of invoice raised for payment of GST so as to enable HPVP to avail input credit.

**9. REVERSE AUCTION:**

- a) BHEL shall be resorting to Reverse Auction (RA) for this tender. RA shall be conducted among the techno-commercially qualified bidders. Business Rules for Reverse Auction are given at Annexure – V. Bidder may refer Guidelines for Reverse Auction on our website, [www.bhel.com](http://www.bhel.com) → supplier registration → Guidelines for Reverse Auction, before submission of their offer.
- b) Sealed envelope / Electronic Price bids of all the techno-commercially qualified bidders shall be opened and the same shall be considered as initial bids of the bidders in RA. In case any bidder(s) do(es) not participate in online Reverse Auction, their sealed envelope / Electronic price bid along with applicable loading, if any, shall be considered for ranking.
- c) BHEL will inform bidders the details of service provider who will provide business rules, all necessary training and assistance before commencement of online bidding. The bidders participating in the Reverse Auction shall have to necessarily submit ‘**Process Compliance Form**’ (PCF) to the designated Service Provider.
- d) Bidders are advised to read the ‘Business Rules’ (Annexure – V) indicating details of RA event carefully, before reverse auction event.

**10. RISK PURCHASE:**

In case the contractor fails to execute the work within the scheduled time or due to any other reasons, BHEL-HPVP reserves the right to get the same completed through some other party at the risk & cost of the contractor and any additional expenditure incurred due to the same shall be charged to the contractor. Non-performance of contractor attracts penal provisions in line with BHEL Guidelines for Suspension of Business Dealings.

**11. GENERAL:**

- a) The bidders shall study the Tender documents, Drawings, Quality Documents and all other relevant documents in detail for understanding the scope of work and the processes involved before submission of offer. Bidders shall get clarifications, if any, from concerned officials on the scope of work or any other details of the tender document, over phone between 09:00 AM and 04:00 PM on any working day (or) through e-mail.
- b) **Conditional / Partial Price Bids** and any other deviations to the tender terms & conditions are not acceptable and BHEL reserves the right to reject such offers without further correspondence. Bidders shall confirm their acceptance to all the terms & conditions of the tender enquiry in the Techno-commercial Bid.
- c) BHEL reserves the right to modify (or) cancel the tender enquiry at any stage without assigning any reasons thereof.
- d) The General Terms & Conditions, if any, contradicting with the specific terms & conditions given in the tender, then specific terms & conditions shall only be considered.
- e) Other Terms & Conditions, whichever are applicable, shall be as per Annexure – III enclosed.

**12. The following documents shall form part of the tender enquiry including this Notice Inviting Tender:**

**PART - 1: TECHNO-COMMERCIAL BID**

- i) Schedule of Quantities : Annexure – I
- ii) Details of Dished Ends to be formed : Annexure – II
- iii) General Terms & Conditions : Annexure – III
- iv) Acceptance to tender terms & conditions : Annexure – IV
- v) Business Rules for Reverse Auction : Annexure – V
- vi) GST Compliance for Indigenous Suppliers : Annexure – GST
- vii) Tentative Drawings, WPS, QAP / SQP etc.

**PART - 2: PRICE BID**

- viii) Price Bid (Schedule of Quantities & Rates)

**13. TENDER SUBMISSION (Through e-Procurement system):**

a) The tender completed in all respects shall be submitted in **Two parts** (Techno-commercial bid and Price Bid) through online e-procurement portal (<https://eprocurebhel.co.in>) latest by **13:00 Hrs. on 19.06.2026**.

**Note:** Techno-commercial bid along with all the tender documents shall be duly signed & stamped by the bidder on all pages.

b) Submission of offer by the bidder implies that all the tender documents were read by the bidder and the bidder is aware of the scope and specifications of the job.

c) **OFFERS SENT IN ANY OTHER FORM WILL BE TREATED AS INVALID AND WILL BE SUMMARILY REJECTED.**

**14. TENDER OPENING:**

a) Techno-commercial Bids will be opened on **19.06.2026 at 15:00 Hrs.** in online e-procurement portal.

b) After evaluation of the Techno-commercial Bids, intimation regarding date & procedure of conducting reverse auction shall be given by the service provider to all eligible techno-commercially qualified bidders through an e-mail in advance at an appropriate time.

For Bharat Heavy Electricals Limited,

  
09/06/2026  
**D. N. MURTHY**  
Manager (OS)  
Bharat Heavy Electricals Ltd  
4PVP Visakhapatnam-530 017

Tender Enquiry ref.: OS/26-27/CS DE/12/012

Date: 09.06.2026

Sub: Forming of CS Dished Ends against SO Nos. 8117, 8136, 8158, 8159, 8160, 8170, 8194, 8195, 8207 & 8208 at vendor works with free issue materials

**SCHEDULE OF QUANTITIES**

Sl. No.	Description of Item	Unit	Qty.
1	<u>Torispherical Dished ends</u> ID 1468 mm x 14 mm (Min) Thk. from a blank of OD 1860 mm x 16 mm thk. - <b>Wt. 341 Kgs. each</b> Matl. Specn.: SA 516Gr.70	Nos.	6
2	<u>Torispherical Dished ends</u> ID 1968 mm x 13.5 mm (Min) Thk. from a blank of OD 2428 mm x 16 mm thk. - <b>Wt. 581 Kgs. each</b> Matl. Specn.: SA 516Gr.70	Nos.	6
3	<u>2:1 Ellipsoidal Dished ends</u> ID 1472 mm x 12 mm (Min) Thk. from a blank of OD 1900 mm x 14 mm thk. - <b>Wt. 312 Kgs. each</b> Matl. Specn.: SA 516Gr.70	Nos.	2
4	<u>2:1 Ellipsoidal Dished ends</u> ID 3450 mm x 20 mm (Min) Thk. from a blank of OD 4390 mm x 25 mm thk. - <b>Wt. 3785 Kgs. each</b> Matl. Specn.: SA 516Gr.70	Nos.	2
5	<u>2:1 Ellipsoidal Dished ends</u> ID 1468 mm x 12 mm (Min) Thk. from a blank of OD 1958 mm x 16 mm thk. - <b>Wt. 356 Kgs. each</b> Matl. Specn.: SA 516Gr.70	Nos.	1
6	<u>2:1 Ellipsoidal Dished ends</u> ID 3390 mm x 18.8 mm (Min) Thk. from a blank of OD 4405 mm x 25 mm thk. - <b>Wt. 3000 Kgs. each</b> Matl. Specn.: SA 516Gr.70	Nos.	4
	<b>Total</b>		<b>21</b>

**Notes :**

- 1) **a) L1 status will be evaluated based on total quoted price.**  
**b) Bidder has to quote for all the items. Part quotation is not acceptable.**
- 2) The quantity indicated above is tentative and may vary subject to the requirement at the time of ordering / execution. However, payment shall be made for the actual quantity only.
- 3) The prices shall be fixed & firm without any escalation during the entire period of contract and till completion of work.
- 4) The quoted price shall be inclusive of all applicable taxes & duties except GST. However, GST shall be reimbursed by BHEL on submission of proof of GST payment.
- 5) The bidders are advised to go through all the drawings & documents before quoting the tender.

**Signature of the bidder with Stamp**

**DETAILS OF DISHED ENDS TO BE FORMED**

Sub: Forming of CS Dished Ends against SO Nos. 8117, 8136, 8158, 8159, 8160, 8170, 8194, 8195, 8207 &amp; 8208 at vendor works with free issue materials

Sl. No.	Sale order no.	Equipment Name	Head	ID (mm)	Min. Thk (mm)	Nom. Thk (mm)	SF (mm)	Blank Size (mm)	Qty. (No.)	No. of Chordal Joints in Blank	Blank Unit Weight (Kg)	Total Weight (Kg)	Material Specn.	Remarks
1.1	8136, 8194 & 8195	CBD Tank	Torispherical	1468	14	16	50	1860	2	Nil	341	682	SA516Gr70	
1.2	8170	CBD Tank	Torispherical	1468	14	16	50	1860	2	Nil	341	682	SA516Gr70	
1.3	8158, 8159 & 8160	CBD Tank	Torispherical	1468	14	16	50	1860	2	Nil	341	682	SA516Gr70	
2.1	8136, 8194 & 8195	IBD Tank	Torispherical	1968	13.5	16	50	2428	2	Nil	581	1162	SA516Gr70	
2.2	8170	IBD Tank	Torispherical	1968	13.5	16	50	2428	2	Nil	581	1162	SA516Gr70	
2.3	8158, 8159 & 8160	IBD Tank	Torispherical	1968	13.5	16	50	2428	2	Nil	581	1162	SA516Gr70	
3	8117	IBD Tank	2:1 Ellipsoidal	1472	12	14	50	1900	2	Nil	312	624	SA516Gr70	
4	8117	Deaerator FST	2:1 Ellipsoidal	3450	20	25	50	4390	2	1 Joint	3785	7570	SA516Gr70	
5	8117	Deaerator Heater	2:1 Ellipsoidal	1468	12	16	50	1958	1	Nil	356	356	SA516Gr70	
6.1	8207	Flash Tank	2:1 Ellipsoidal	3390	18.8	25	50	4405	2	1 Joint	3000	6000	SA516Gr70	
6.2	8208	Flash Tank	2:1 Ellipsoidal	3390	18.8	25	50	4405	2	1 Joint	3000	6000	SA516Gr70	
		<b>TOTAL</b>							<b>21</b>			<b>26082</b>		

**GENERAL TERMS & CONDITIONS**

**1. TECHNICAL DELIVERY CONDITIONS:**

The work should conform to the technical data given in our drawings, GMS, Shipping List Specifications, QAP, WPS etc.

**2. PARTY'S SCOPE:**

The scope of the party shall be as follows: -

- a) All welding equipments, baking oven, tools, jigs and fixtures, measuring instruments duly calibrated, handling facilities, testing facilities etc.
- b) All materials other than those mentioned under "Free Issue Materials", which are required for completion of the work.
- c) All consumables such as electrodes, gases, grinding wheels etc.

**Note: Electrodes of specification mentioned in the drawings / WPS and of BHEL approved brands only shall be used and MTCs of the same shall be submitted to BHEL for verification before use.**

**3. REVISION OF DRAWINGS:**

There may be minor changes in the drawings during execution. In such a case, party should accommodate the same without any extra claim.

**4. WELDING QUALIFICATION: Qualification of required number of Welders is party's responsibility at their cost.**

**5. X-RAY:**

All welding shall be of X-ray quality where specified on drawings. Inspection would specify the quantum of X-ray based on drawings / code requirement. Party should strictly follow the WPS and QAP issued by BHEL during welding. Getting the welds radiographed and getting them cleared by inspection is the responsibility of the party.

**6. RECTIFICATIONS / REJECTIONS:**

Any rectification due to defective work, if required, shall be done by the party free of charge with a suitable technology approved before hand by BHEL in writing. The cost of material, if any used for rectification work / rejection work, will be estimated by BHEL and the same shall be debited to party's account. In case any rectification / rework is to be carried out due to defective material supplied by BHEL, the replacement material and consumables will be supplied by BHEL free of Cost.

**7. SECURITY DEPOSIT:**

- a) Vendors shall have to submit a Bank Guarantee for **10%** of the order value in case of **HPVP ADM / Lovagarden site** (or) **25%** of the material cost in case of Vendor works towards Security Deposit and safe custody of free issue materials within 15 days from the date of intimation by Outsourcing dept. The BG shall be valid for the contract period with a claim period of 12 months. This Bank Guarantee shall be released to the contractor after completion of work and on acceptance of the same by BHEL / Owner. Bidder agrees to submit performance security required for execution of the contract within the time period mentioned above. In case of delay in submission of performance security, enhanced performance security which would include interest (Repo rate + 4%) for the delayed period, shall be submitted by the bidder. Further, if performance security is not submitted till such time the first bill becomes due, the amount of performance security due shall be recovered as per terms defined in NIT/contract, from the bills along with due interest.
- b) **MODE OF DEPOSIT:** Security Deposit may be furnished in the following forms:
  - i) Local cheques of Scheduled Banks (subject to realization)/ Pay Order/ Demand Draft/ Electronic Fund Transfer in favour of BHEL.
  - ii) Bank Guarantee from Scheduled Banks / Public Financial Institutions as defined in the Companies Act. The Bank Guarantee format should have the approval of BHEL.
  - iii) Fixed Deposit Receipt issued by Scheduled Banks / Public Financial Institutions as defined in the Companies Act (FDR should be in the name of the Contractor, a/c BHEL).
  - iv) Securities available from Indian Post offices such as National Savings Certificates, Kisan Vikas Patras etc. (held in the name of Contractor furnishing the security and duly endorsed/ hypothecated/ pledged, as applicable, in favour of BHEL).
  - v) Insurance Surety Bond.

(Note: BHEL will not be liable or responsible in any manner for the collection of interest or renewal of the documents or in any other matter connected therewith).

**8. PERFORMANCE BANK GUARANTEE:**

Vendors shall have to submit Performance Bank Guarantee (claim period of 12 months) for 10% of the order value covering for the defects liability period. If PBG is not submitted, 10% of the order value shall be deducted towards PBG from the final bill and shall be refundable after performance guarantee period, if no defects are found during this period.

**9. RAW MATERIALS ISSUE:**

Raw materials shall be issued with appropriate processing allowance and invisible wastage over the theoretical requirement of raw materials (**Plates, Sheets, Sections and Pipes**).

**10. TRANSFER / RETURN OF LEFT-OVER MATERIALS:**

Party should maintain proper records for receipt & use of all free issue materials. The left-over materials & scrap as per the material accounting statement shall be returned to HPVP stores along with finished job. Material Transfer Vouchers (MTV) from one order to another or from one vendor to another and Material Return Vouchers should be submitted immediately after transfer / return. The material reconciliation statement shall be submitted by the contractor after verification and certification by BHEL along with the final bill **within 30 days from the date of completion of work**. Otherwise, recovery for the balance materials shall be made from any of their pending bills without further intimation.

**11. MATERIAL RECONCILIATION:**

Orders issued to the vendors have to be completed in all respects including Material Accounting within a maximum of **180 days** from the **date of issue of material** from BHEL - HPVP stores.

**Maximum of 0.5 %** on the requirement of materials (**Plates, Sections and Pipes**) is admitted towards **process allowance and invisible wastage**.

Scrap quantity is permissible up to a **maximum of 1% on Structural (Beams, Channels, Angles, Rods, Pipes etc.), 2% on Sheets, 3% for Plates** on the theoretical requirement of materials.

**If wastage and scrap is beyond the above limits**, it should be fully justified with cutting diagrams etc. which are to be approved in advance by BHEL. **Otherwise, the cost of raw materials beyond approved limits will be recovered from the contractor as per BHEL recovery rates including applicable taxes & duties.**

Material reconciliation including return of balance materials, off-cuts is to be completed within 20 days from the date of completion of the order. The material reconciliation statement shall be submitted by the contractor after verification and certification by BHEL-HPVP along with the final bill **within 30 days from the date of completion of work**. Otherwise, recovery for the balance materials shall be made from any of their pending bills without further intimation,

Repeated occurrence of inordinate delays in returning and settling the material accounting will entail BHEL the right to terminate the contract forthwith or impose a temporary suspension on further loading at the discretion of BHEL.

**12. SCRAP & OFF-CUT NORMS:**

Sl. No.	Description	Scrap Size (in mm)	Off-Cut (in MM)
1.	CS/AS Sheets & Plates	Below 500 × 250	500 × 250 & above
2.	Rolled sections Rod, angles etc. (other than -tubes, pipes)	Below 1000	1000 & above
3.	Tubes & Pipes	Below 500	500 & above
4.	Universal column	Below 1000	1000 & Above
5.	SS Sheets & Plates	Below 500 × 250	500 × 250 & above
6.	SS Structural, Rods, Tubes, Pipes	Below 250	250 & above
7.	Non – ferrous: sheets & plates, rods & tubes	Below 500 × 250 (S & PL), Below 250 (Rods & Tubes)	500 × 250 & above, 250 & above
8.	Big size Scrap	(2500 & above) × (150 to 249)	-

**13. INSPECTION:**

Party shall contact our Quality Control Dept. for stages of inspection before commencement of job and should strictly follow the stages of inspection as per QAP.

**14. WORKMANSHIP GUARANTEE:**

The vendors should give workmanship guarantee for fabricated items for a period of 18 months from the date of last delivery of the order. Any defects due to incomplete work, faulty workmanship found in the fabricated items after delivery during the defects liability period shall be rectified / replaced by the vendor free of cost. Otherwise, the expenditure incurred towards the same will be recovered from the pending bills of vendors.

**15. WORK PROGRESS:**

The fabricator shall furnish a weekly report on the progress of work along with the status of availability of free issue materials and requirement of further materials, if any.

Outsourcing dept. personnel will visit vendor's works from time to time to assess and review the work progress. Free access shall be provided to BHEL or its inspection agency at all reasonable times of the day / night.

In case the progress is not satisfactory or supplies are delayed abnormally beyond the contractual delivery date, BHEL-HPVP, Visakhapatnam reserves the right to cancel the order in part or full or get the balance job in as is where is condition completed elsewhere by another agency at the risk and cost of Fabricator. The value of the work carried out by the party will be assessed by BHEL and the same shall be final. No compensation will be given to the fabricator in case of cancellation of order or diversion of balance job even if the jobs have been processed partly.

**16. DELIVERY:**

Finished items should be handed over to BHEL-HPVP on party's delivery challans along with Job completion certificate / Final Inspection Report from inspection agency / HPVP-QC department.

**17. PENALTY:**

Penalty calculations will be done on DU wise (Dispatchable Unit) delivery. If delivery exceeds the stipulated delivery schedule, penalty @ 1/2 % of the value of each DU per week (or) part thereof subject to a maximum of 10% of the value of each DU will be levied. However, time taken for the following will not be considered as delay on the part of the Sub-Contractor.

- 1) Intermediate operations, if any, carried out by BHEL.
- 2) Waiting time for BHEL / Third party Inspection beyond a normal time of 3 days.

**18. PAYMENT TERMS:**

Payment shall be made against RA Bills within 45 days for MSE (Micro & Small Enterprise), 60 days for Medium Enterprise and 90 days for non-MSEs from the date of submission of Bill.

90% payment will be made after handing over of the finished equipments along with all inspection documents to HPVP shops / Logistics dept. / ADM site / Lova Garden site, duly inspected & cleared by Inspection authority. Balance 10% payment shall be made along with the Final Bill against completion of total order in all respects including documentation.

Vendors shall have to submit the bills in the formats specified by HPVP-Outsourcing and the bills submitted in the specified format along with necessary supporting documents are only admitted for processing. The following documents shall be submitted along with the Final Bill:

1. No Claim Certificate from the contractor
2. No Dues Certificate from BHEL
3. Work Completion Certificate from BHEL
4. Material Reconciliation Statement submitted by the Contractor and certified by concerned authority of BHEL (if applicable)
5. Workmanship Guarantee certificate from the contractor

**19. SECRECY:**

All the documents of BHEL inclusive of Drawings, GMS and Standards made available to the fabricator should be kept in strict confidence and under no circumstance be made available to others or allow others to make use of them. Such documents shall be returned to BHEL on demand after completion of the job. This secrecy clause is binding on the employees of the fabricators also. Violation of the same may lead to suspension of business with the vendor and necessary legal action.

**20. SUB-LETTING:**

In general, sub-letting of jobs will not be permitted. But in special circumstances, this may be allowed. In such case, the party should obtain written approval from BHEL-HPVP, Visakhapatnam before sub-letting.

**21. FACTORY RULES AND REGULATIONS:**

Party shall abide by all the rules and statutory regulations in force from time to time as per factories act. It shall be party's responsibility to ensure the safety of their workmen and fulfilling the ESI, PF and other relevant statutory regulations.

**22. SAFETY:**

- a) Contractor shall adhere to safe construction practices, guard against hazardous & unsafe working conditions and shall comply with the safety rules of BHEL and local authorities. He shall maintain First Aid facilities for all his employees and labour. Contractor's responsibility includes supply of welder kit, all safety items such as safety belts, white and colour glasses, goggles, safety helmets, safety shoes etc.
- b) Contractor and his employees shall follow all fire & safety, security regulations of BHEL.

**23. HOUSE KEEPING:**

During execution of work, the contractor at all times keep the working place and storage area clean and free from accumulation of waste materials, rubbish etc.,

**24. ACCIDENT / DAMAGE / CONDUCT ETC.:**

Contractor will be held responsible for any disorderly conduct / misconduct, indiscipline, theft, smoking etc., on the part of his men. He will ensure summarily eviction of such men from his premises failing which BHEL would remove them from the factory on his responsibility. Any damage to and or loss of equipment, machinery, building etc., to BHEL or BHEL employees, visitors or other contractors resulting from his own or any of his men's negligence shall be liable to be made good by him. Contractor shall be solely responsible for any accident in which you or your men or your equipment may be involved during the execution of contract on account of any reason what so ever.

**25. TERMINATION OF CONTRACT:**

In the event of any failure on the part of the contractor, BHEL reserves the right to terminate the contract by giving a notice of 2 weeks for any of the following lapses and contractual violations: -

- a) Failure to make labour payments in time as per the rules
- b) Failure to progress the job according to the agreed schedule
- c) Failure to mobilize adequate man power, tools & tackles and consumables in time
- d) Failure to adhere to Quality Standards of BHEL
- e) Refused to co-operate with other agencies working in the same area
- f) Failure to resolve labour disputes like strikes etc., within 7 days of occurrence
- g) Failure to comply with statutory regulations applicable at BHEL

BHEL shall also be free to intervene and take necessary remedial measures. All costs incurred with interest and overheads shall be recovered from contractor by such foreclosing or off-loading any part of the contract work.

**26. CONFLICT OF INTEREST AMONG BIDDERS / AGENTS:**

A bidder shall not have conflict of interest with other bidders. Such conflict of interest can lead to anti-competitive practices to the detriment of Procuring Entity's interests. ***The bidder found to have a conflict of interest shall be disqualified.*** A bidder may be considered to have a conflict of interest with one or more parties in this bidding process, if:

- a) they have controlling partner (s) in common; **or**
- b) they receive or have received any direct or indirect subsidy / financial stake from any of them; **or**
- c) they have the same legal representative / agent for purposes of this bid; **or**
- d) they have relationship with each other, directly or through common third parties, that puts them in a position to have access to information about or influence on the bid of another Bidder; or
- e) Bidder participates in more than one bid in this bidding process. Participation by a Bidder in more than one Bid will result in the disqualification of all bids in which the parties are involved. However, this does not limit the inclusion of the components/ sub-assembly/ Assemblies from one bidding manufacturer in more than one bid; or
- f) In cases of agents quoting in offshore procurements, on behalf of their principal manufacturers, one agent cannot represent two manufacturers or quote on their behalf in a particular tender enquiry. One manufacturer can also authorise only one agent / dealer. There can be only one bid from the following:
  - 1. The principal manufacturer directly or through one Indian agent on his behalf, and
  - 2. Indian/foreign agent on behalf of only one principal,
- g) A Bidder or any of its affiliates participated as a consultant in the preparation of the design or technical specifications of the contract that is the subject of the Bid, **or**
- h) In case of a holding company having more than one independently manufacturing units, or more than one unit having common business ownership/management, only one unit should quote. Similar restrictions would apply to closely related sister companies. Bidders must proactively declare such sisters' common business/ management units in same/ similar line of business"

**27. TAXES & DUTIES:**

- a) BOCW Cess if applicable is to be paid by Contractor.
- b) In addition to existing taxes, any new taxes, cess, duties, levies imposed by Central/ State Govt. shall be borne by the contractor.
- b) In case, any new tax is imposed instead of existing tax, difference of the amount shall be reimbursed/ recovered on submission of documentary evidence.
- c) Any new tax is imposed by Central/ State Govt. (or) there is any variation in taxes after expiry of delivery / contract period, the same shall be borne by contractor only.
- d) All terms & conditions of the contract in respect of taxes & duties are subject to new taxation laws introduced from time to time by Govt. and Terms & conditions will deemed to be modified in accordance with the provisions of New Laws.

**28. CONTRACTOR'S MATERIAL:**

Security of Contractor's Equipment, Tools & Tackles, Machinery etc., is in the scope of Contractor. BHEL is not responsible for the same.

**29. RETURNING OF BHEL MATERIAL:**

All Materials, machinery, equipment etc., of BHEL sent to site from BHEL-HPVP for execution of the Order are to be returned back to BHEL by the Contractor.

**30. OVER RUN COMPENSATION (ORC) / IDLE CHARGES:**

The contractor shall not be entitled to claim and the company shall not be liable to pay any amount on account of overrun compensation and idle charges, the overrun/ idling may be for whatsoever reasons.

**31. DISPUTES:**

Head of BHEL- HPVP Unit will be the final authority for any disputes arising out of this contract. The disputes / arbitration / settlement of contractual or legal issues shall be under the Jurisdiction of Visakhapatnam Court.

- 32.** For this procurement, Public Procurement (Preference to Make in India), Order 2017 dated 15.06.2017 & 28.05.2018 and subsequent Orders issued by the respective Nodal Ministry shall be applicable even if issued after issue of this NIT but before finalization of Contract / PO / WO against this NIT.

In the event of any Nodal Ministry prescribing higher or lower percentage of purchase preference and / or local content in respect of this procurement, same shall be applicable.

- 33.** The Bidder declares that they will not enter into any illegal or undisclosed agreement or understanding, whether formal or informal with other Bidder(s). This applies in particular to prices, specifications, certifications, subsidiary contracts, submission or non-submission of bids or any other actions to restrict competitiveness or to introduce cartelization in the bidding process.

In case, the Bidder is found having indulged in above activities, suitable action shall be taken by BHEL as per extant policies/ guidelines.

**34. GRIEVANCE REDRESSAL MECHANISM:**

To promote transparency and ensure fair treatment of all bidders, a structured Grievance Redressal Mechanism is in place to address any concerns or issues arising during the tendering process or in subsequent business dealings with the company.

Suppliers/Contractors are requested to follow the below escalation process for grievance resolution:

- 1. **First Level:** Any grievance should initially be addressed to the designated Dealing Officer, whose contact details are provided in the Notice Inviting Tender (NIT) / Contract.
- 2. **Second Level:** If the issue remains unresolved, it may be escalated by lodging a formal grievance through the SUVIDHA Portal: <https://suvidha.bhel.in/suvidha/>. Responses will be provided in accordance with the defined escalation matrix."

**35. ORDER ACCEPTANCE:**

If the order acceptance is not received within 03 days from the date of release of Sub-contract order, it shall be assumed that the same has been accepted by you thereof.

**Signature of the Bidder with stamp**

**Acceptance to Tender Terms & Conditions**

I / We hereby confirm that the Tender documents, Drawings, Quality documents etc. have been studied in detail and we have fully understood the scope of work.

I / We accept to all the Terms and Conditions of the Tender Enquiry without any deviations and the prices quoted are in accordance with the same.

I / We give our acceptance to participate in reverse auction for this tender.

Tender documents duly signed on all the pages by the Owner / authorized representative of the bidder are attached herewith.

**Signature of the bidder with Stamp**

**BUSINESS RULES FOR REVERSE AUCTION (RA)**

This has reference to tender no. **OS/26-27/CS DE/12/012, dated 09.06.2026**. BHEL shall finalise the Rates for **Forming of CS Dished Ends against SO Nos. 8117, 8136, 8158, 8159, 8160, 8170, 8194, 8195, 8207 & 8208 at vendor works with free issue materials** through Reverse Auction mode. BHEL has made arrangement with an authorized Service provider (details will be shared before reverse auction) for conducting RA. Bidders should go through the instructions given below and submit acceptance of the same.

The technical & commercial terms are as per (a) BHEL Tender Enquiry No. **OS/26-27/CS DE/12/012, dated 09.06.2026**, (b) Bidders' technical & commercial bid (in case of two-part bid) and (c) subsequent correspondences between BHEL and the bidders, if any.

**1. Procedure of Reverse Auctioning:**

- i) Price bids of all techno-commercially qualified bidders shall be opened.
- ii) **Reverse Auction:** The 'bid decrement' will be decided by BHEL.
- iii) The lowest bidder in sealed envelope price bid shall be shown as current L1 automatically by the system and no acceptance of that price is required. System shall have the provision to indicate this bid as current L1.
- iv) Bidders by offering a minimum bid decrement or the multiples thereof can displace a standing lowest bid and become "L1" and this continues as an iterative process. However, no bidder shall be allowed to lower its bid below the current L1 by more than 5 decrements at one go.
- v) After the completion of the reverse auction, the Closing Price shall be available for further processing.
- vi) Wherever the evaluation is done on total cost basis, after Reverse Auction, prices of individual line items shall be reduced on pro-rata basis.

**2. Schedule for reverse auction:** The Reverse Auction schedule will be intimated to the techno-commercially qualified bidders at a later stage.**3. Auction extension time:** If a bidder places a bid in the last {...} minutes of closing of the Reverse Auction and if that bid gets accepted, then the auction's duration shall get extended automatically for another {...} minutes, for the entire auction (i.e. for all the items in the auction), from the time that bid comes in. Please note that the auto-extension will take place only if a bid comes in those last {...} minutes and if that bid gets accepted as the lowest bid. If the bid does not get accepted as the lowest bid, the auto-extension will not take place even if that bid might have come in the last {...} minutes. In case, there is no bid in the last {...} minutes of closing of Reverse Auction, the auction shall get closed automatically without any extension. However, bidders are advised not to wait till the last minute or last few seconds to enter their bid during the auto-extension period to avoid complications related with internet connectivity, network problems, system crash down, power failure, etc. The above process will continue till completion of Reverse Auction.

Complaints/ Grievances, if any, regarding denial of service or any related issue should be given in writing thru e-mail/ fax to M/s. {Service provider} with a copy to BHEL within 15 minutes prior to initial closing time of Reverse Auction.

**4. Bid price:** The Bidder has to quote the {...} Price inclusive of Packing & Forwarding charges, all the routine & type tests as per tender scope, taxes, duties, freight and insurance as specified in tender document including loading (if indicated by BHEL due to deviations in technical/ commercial terms) for the Items specified. Details are as shown in Excel Sheet for calculation of total cost to BHEL (To be specified by Unit as per NIT conditions).**5. Bidding currency and unit of measurement:** Bidding will be conducted in *Indian Rupees per Unit* of the material as per the specifications mentioned in the tender.

In case of foreign currency bids, exchange rate (TT selling rate of State Bank of India) as on scheduled date of tender opening (Part-I bid) shall be considered for conversion in Indian Rupees. If the relevant day happens to be a Bank holiday, then the forex rate as on the previous bank (SBI) working day shall be taken.

6. **Validity of bids:** Price shall be valid for 90 days from the date of reverse auction. These shall not be subjected to any change whatsoever.
7. **Lowest bid of a bidder:** In case the bidder submits more than one bid, the lowest bid at the end of Reverse Auction will be considered as the bidder's final offer to execute the work.
8. Unique user IDs shall be used by bidders during bidding process. All bids made from the Login ID given to the bidders will be deemed to have been made by the bidders/ bidders' company.
9. **Post auction procedure:** BHEL will proceed with the Lowest Bid in the Reverse Auction for further processing.
10. Any commercial/ technical loading shall be separately intimated to respective bidders prior to RA. The excel sheet provided in this regard shall cover all these aspects. Commercial/ technical loading if any, shall be added by the respective bidder in its price during Reverse Auction. Modalities of loading & de-loading shall be separately intimated to the bidders. The responsibility for correctness of total cost to BHEL shall lie with the bidders.
11. Reverse auction shall be conducted by BHEL (through M/s {Service Provider}), on pre-specified date, while the bidders shall be quoting from their own offices/ place of their choice. Internet connectivity shall have to be ensured by bidders themselves.

During the RA process if a bidder is not able to bid and requests for extension of time by FAX/ email/ phone then time extension of additional 15 minutes will be given by the service provider provided such requests come before 5 minutes of auction closing time. However, only one such request per bidder can be entertained.

In order to ward-off contingent situation of connectivity failure bidders are requested to make all the necessary arrangements/ alternatives whatever required so that they are able to circumvent such situation and still be able to participate in the reverse auction successfully. Failure of power or loss of connectivity at the premises of bidders during the Reverse auction cannot be the cause for not participating in the reverse auction. On account of this, the time for the auction cannot be extended and neither BHEL nor M/s. {Service provider} is responsible for such eventualities.

12. **Proxy bids:** Proxy bidding feature is a pro-bidder feature to safe guard the bidder's interest of any internet failure or to avoid last minute rush. The proxy feature allows bidders to place an automated bid in the system directly in an auction and bid without having to enter a new amount each time a competing bidder submits a new offer. The bid amount that a bidder enters is the minimum that the bidder is willing to offer. Here the software bids on behalf of the bidder. This obviates the need for the bidder participating in the bidding process until the proxy bid amount is decrementally reached by other bidders. When proxy bid amount is reached, the bidder (who has submitted the proxy bid) has an option to start participating in the bidding process.

The proxy amount is the minimum amount that the bidder is willing to offer. During the course of bidding, the bidder cannot delete or change the amount of a proxy bid.

Bids are submitted in decrements (decreasing bid amounts). The application automates proxy bidding by processing proxy bids automatically, according to the decrement that the auction originator originally established when creating the auction, submitting offers to the next bid decrement each time a competing bidder bids, regardless of the fact whether the competing bids are submitted as proxy or standard bids. However, it may please be noted that if a manual bid and proxy bid are submitted at the same instant manual bid will be recognized as the L1 at that instant.

In case of more than one proxy bid, the system shall bid till it crosses the threshold value of 'each lowest proxy bid' and thereafter allow the competition to decide the final L1 price.

Proxy bids are fed into the system directly by the respective bidders. As such this information is privy only to the respective bidder(s).

13. Bidders are advised to get fully trained and clear all their doubts such as refreshing of Screen, quantity being auctioned, tender value being auctioned etc. from M/s. {Service provider}.

14. M/s. {*Service provider*}, shall arrange to demonstrate/ train the bidder or bidder's nominated person(s), without any cost to bidders. M/s. {*Service provider*}, shall also explain the bidders, all the business rules related to the Reverse Auction. Bidders are required to submit their acceptance to the terms/ conditions/ modalities before participating in the Reverse Auction in the process compliance form as enclosed. Without this, the bidder will not be eligible to participate in the event.
15. Successful bidder shall be required to submit the final prices (L1) in prescribed format (Annexure – VI) for price breakup, quoted during the Reverse Auction, duly signed and stamped as token of acceptance without any new condition (other than those already agreed to before start of auction), after the completion of auction to M/s. {*Service provider*} besides BHEL within two working days of Auction without fail.
16. Any variation between the final bid value and that in the confirmatory signed price breakup document will be considered as tampering the tender process and will invite action by BHEL as per extant guidelines for suspension of business dealings (as available on [www.bhel.com](http://www.bhel.com)).
17. Bidders' bid will be taken as an offer to execute the work/ supplies the item as per enquiry no. **OS/26-27/CS DE/12/012, dated 09.06.2026**. Bids once made by the bidder, cannot be cancelled/ withdrawn and bidder shall be bound to execute the work as mentioned above at bidder's final bid price. Should bidder back out and not execute the contract as per the rates quoted, BHEL shall take action as per extant guidelines for suspension of business dealings (as available on [www.bhel.com](http://www.bhel.com)).
18. Bidders shall be able to view the following on their screen along with the necessary fields during Reverse Auction:
  - a. Leading (Running Lowest) Bid in the Auction (only total price of package)
  - b. Bid Placed by the bidder
  - c. Start Price
  - d. Decrement value
  - e. Rank of their own bid during bidding as well as at the close of auction.
19. BHEL's decision on award of contract shall be final and binding on all the Bidders.
20. BHEL reserves the right to extend, reschedule or cancel the Reverse Auction process at any time, before ordering, without assigning any reason, with intimation to bidders.
21. BHEL shall not have any liability to bidders for any interruption or delay in access to the site irrespective of the cause. In such cases, the decision of BHEL shall be binding on the bidders.
22. Other terms and conditions shall be as per bidder's techno-commercial offers and other correspondences, if any, till date.
23. If there is any clash between this business document and the FAQ available, if any, in the website of M/s. {*Service provider*}, the terms & conditions given in this business document will supersede the information contained in the FAQs. Any changes made by BHEL/ service provider (due to unforeseen contingencies) after the first posting shall be deemed to have been accepted if the bidder continues to access the portal after that time.
24. Bidder shall not divulge either his Bids or any other exclusive details of BHEL to any other party. If the Bidder or any of his representatives are found to be involved in Price manipulation/ cartel formation of any kind, directly or indirectly by communicating with other bidders, action *as per extant BHEL guidelines for suspension of business dealings (as available on [www.bhel.com](http://www.bhel.com))*, shall be initiated by BHEL.

**Signature of the Bidder with Stamp**

**GST COMPLIANCE FOR INDIGENOUS SUPPLIERS**

1. In Response to Tenders for Indigenous supplier will be entertained only if the vendor has a valid GSTIN which should be clearly mentioned in the offer. If any specific exemption is available, a declaration with due supporting documents need to be furnished for considering the offer.
2. Supplier shall mention their GSTIN in all their invoices and invoices shall be in the format as specified/prescribed under GST laws. Invoices shall necessarily contain Invoice number (in case of multiple numbering system is being followed for billing like SAP invoice no, commercial invoice no etc., then the Invoice No which is linked/uploaded in GSTN network shall be clearly indicated), item description as per PO, Quantity, Rate, Value, applicable taxes with nomenclature (like IGST, SGST, CGST & UTGST) separately, HSN/ SAC Code, etc.
3. All invoices shall bear the HSN Code for each item separately (Harmonized System of Nomenclature)/ SAC code (Services Accounting Code).
4. A declaration to the effect that all invoice particulars are/were uploaded in the GSTN network/ portal & all tax liability as per GST rules and regulations have been and will be discharged, shall be mentioned in the invoice. If not mentioned in the invoice, a separate declaration shall be submitted as per the requirement of BHEL.
5. All documents like Test Certificate, LR copy, Guarantee/Warranty certificate, work completion certificate, any other document mentioned in PO, shall be sent along with the vehicle/consignment where ever applicable. For all consignments received within the calendar month, input credit will be availed within that month in line with monthly returns filing cycle. In case of any discrepancy in the document or non-submission of documents mentioned in the PO, then BHEL will not be able to accept or account the material, in such case availing of tax credit will be deferred to next month or so.
6. In case of discrepancy in the data uploaded by supplier in the GSTN portal or in case of any shortages or rejection in the supply, then BHEL will not be able to avail the tax credit and will notify the supplier of the same. Supplier has to rectify the data discrepancy in the GSTN portal or issue credit note (details to be uploaded in GSTN portal) for the shortages or rejections in the suppliers, within the calendar month notified by BHEL.
7. For any such delay in availing of tax credit for reasons attributable to supplier (as mentioned above), interest (calculated @ SBI Base Rate + 6%) along with penalty if any will be deducted for the delayed period i.e. from the month of receipt till the month tax credit is availed, from the running bills.
8. Under GST regime, BHEL has to discharge GST liability on LD recovered from suppliers/contractors. Hence applicable GST shall also be recoverable from suppliers/contractors on LD amount. For this Debit note will be issued by BHEL indicating the respective supply invoice number.
9. This is to inform that GST portion of invoice, shall be released only upon Vendor declaring such invoice in his GSTR-1 and receipt of goods and Tax invoice by BHEL and Confirmation of payment of GST thereon by vendor on GSTN portal. Alternatively, BG of appropriate value may be obtained from vendor which shall be valid At least one month after the confirmation of date of payment of GST by vendor on GSTN portal and receipt of Tax invoice and receipt of goods, whichever is later. Above is subject to receipt of goods/service and tax invoice thereof along with vendor declaring invoice in his return and paying GST within timeline prescribed for availing ITC by BHEL.
10. That in case vendor delays Declaring such invoice in his return and GST credit availed by BHEL is denied or reversed subsequently as per GST law, GST amount paid by BHEL towards such ITC reversal as per GST law shall be recoverable from vendor/contractor along with interest levied/ leviable on BHEL.

***Note: The above will be followed strictly for processing vendor payments to ensure GST Compliance.***

**Signature of the Bidder with Stamp**

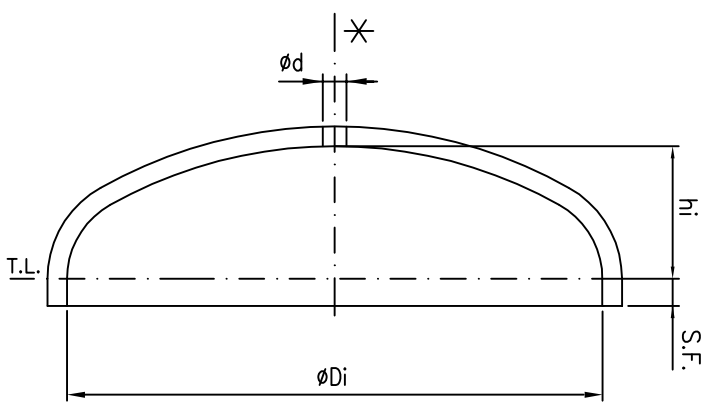

(PROFILE - 2:1 ELLIPSOIDAL)

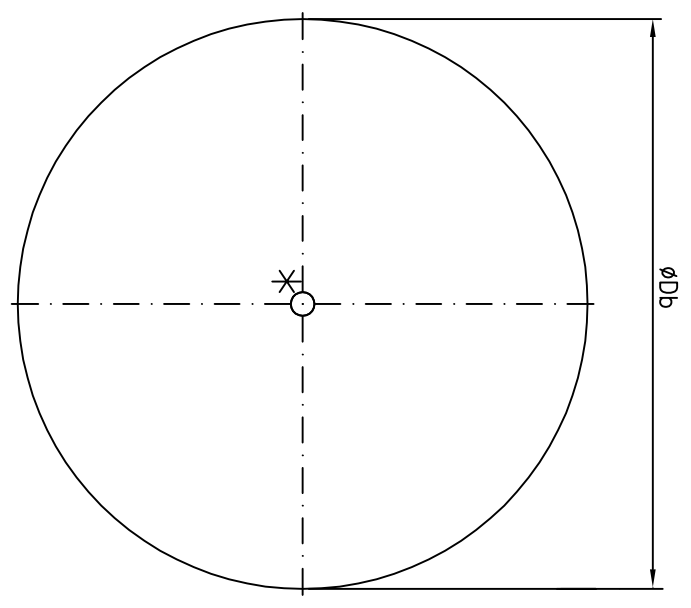

DETAIL OF BLANK

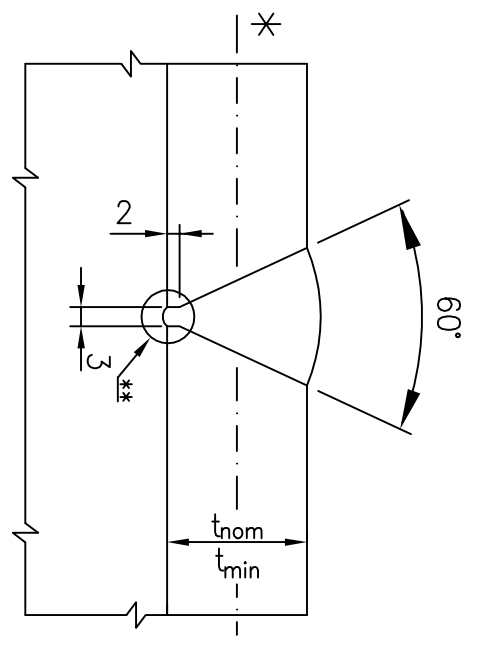

DETAIL - "A"

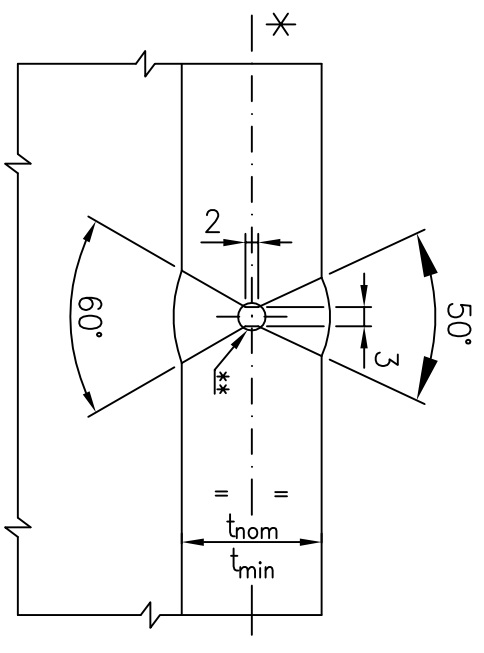

DETAIL - "B"

- $\phi d$  - DIA OF HOLE
- $\phi D_i$  - DISHED END I.D.
- $\phi D_b$  - BLANK DIA
- $h_i$  - HEIGHT OF DISHED END
- S.F. - STRIGHT FACE

NOTES:-

- 1.) NDT REQUIREMENTS TO BE FOLLOWED AS PER THE GENERAL NOTES / DISH END DRAWING
- 2.) FOR SIZES, MATERIAL & WELD DETAIL "A/B" REFER SUB CONTRACT ORDER / PURCHASE ORDER / GENERAL NOTES.
- 3.) \*\*CHIP BACK TO SOUND METAL & REWELD

REV. NO.	ZONE	BRIEF RECORD OF REVISIONS	PPD.	CHD.	APPD.	DATE

CAUTION: The information on this document is the property of BHARAT HEAVY ELECTRICALS LTD. It must not be used directly or indirectly in any way detrimental to the interest of the company.

		<b>Bharat Heavy Electricals Ltd</b> VISHKARPATMAN-590012 VISHKARPATMAN-590012		DATE: 20.02.26 TIME: 20.02.26 DATE: 20.02.26
DESK: P/BLANK CODE: 01 ALL DIMENSIONS IN MM PROJECTION: 1st Angle SCALE: NTS WEIGHT (kg): XXXX	TITLE: TYPICAL SKETCH FOR BLANKING OF DISHED END CENTER HOLE	DRW: LK/M CHK: S MANDAL APP: S MANDAL	NAME: SSNM LK/M S MANDAL	DATE: 20.02.26 TIME: 20.02.26 DATE: 20.02.26
DRAWING NO: 4-02-000-16868			REV: 00	REV: 00



A Maharatna Company

एन टी पी सी लिमिटेड

(भारत सरकार का उद्यम)

NTPC Limited

(A Govt. of India Enterprise)

(Formerly National Thermal Power Corporation Ltd.)

(केंद्रीय कार्यालय नोएडा)

Corporate Center NOIDA

Reference : CC-ENGG-1241-001-102-PESD-QVM-Q-001

Date : 14/05/2026

From : PREM SINGH  
SENIOR MANAGER

To : BHEL DELHI  
SIRIFORT, BHEL HOUSE,P.S.PROJECT  
MANAGEMENT GRP BHEL  
NEW DELHI  
110049

Cc :

Subject : Ex Works (India) Supply for EPC Package for 1X660 MW Ultra Super critical Unit#6 at Amarkantak TPS, Chachai.

Please find enclosed following drawings/ documents for necessary action at your end.

Vendor Drg. No. : BP-QP-1241-100-001  
Orgn. Drg. No. : 1241-001-102-PESD-QVM-Q-001  
Revision No. : 00  
Drg. Title : QAP for Tanks and Vessels  
App. Category : CAT-I  
Release Date : 14/05/2026



Scan to verify

Comments : Approved in CAT-I with Comments



Engineering Division  
ISO 9001:2008 Certified



अभियंत्रिकी कार्यालय परिसर, प्लॉट नं.- ए 8ए, सेक्टर-24, पोस्ट बॉक्स नं.- 13, नोएडा (उ प) पिन-201 307  
टेलिफोन नं.- 0120-2410333, 2410116 फेक्स-0120-2410136, 2410137

पंजीकृत कार्यालय: एनटीपीसी भवन, स्कोप कॉम्प्लेक्स, 7 इंस्टीट्यूशनल एरिया, लोधी रोड, नई दिल्ली-110 003

टेलिफोन नं.- 011-24361018 फेक्स-011-24361018, वेबसाइट: www.ntpc.co.in

ENGINEERING OFFICE COMPLEX, Plot No: A-SA, Sector-24, Post Box No: 13, Noida (UP), Pin-201 307

Telephone No: 0120-2410333, 2410116 Fax-0120-2410136, 2410137

Registered Office: NTPC Bhawan, Scope Complex, 7 Institutional Area, Lodhi Road, New Delhi-110 003

Telephone No: 011 24360100 Fax: 011 24361018, Website: www.ntpc.co.in





## MPPGCL AMARKANTAK

TITLE OF THE DRAWING / DOCUMENT	QAP FOR TANKS AND VESSELS
BHEL DRG NO	PESD/QA/TANK /1/25-26

This Std. MQP is applicable for SG area - Low Pressure Tanks and vessels.



0	24-04-2026	FOR APPROVAL	AKN		AKN		AKN	Sd
REV NO.	DATE	STATUS	INITIALS	SIGN	INITIALS	SIGN	INITIALS	SIGN
			PRPD. BY		CHKD. BY		APPRD. BY	
PROJECT: MPPGCL AMARKANTAK							REV 0	
							Date: 24-04-2026	Page 1 of 1



	<b>STANDARD MANUFACTURING QUALITY PLAN</b>				QP. NO.: PESD/QA/TANK /1/25-26			
	<b>PROJECT ENGINEERING &amp; SYSTEMS DIVISION</b> BHEL-HYD 502032		PRODUCT : TANKS & VESSELS PROJECT: MPPGCL AMARKANTAK		REV NO: 00		DATE: 05.02.2026	
					PAGE 1 OF 6			

SL. NO	COMPONENT & OPERATIONS	CHARACTERISTICS	CLASS	CLASS TYPE OF CHECK	QUANTUM OF CHECK		REFERENCE DOCUMENT	ACCEPTANCE NORMS	FORMAT OF RECORD		AGENCY			REMARKS
					M	C / N				D*	M	C	N	
1	2	3	4	5	6		7	8	9	D*	** 10			11



1.0 RAW MATERIAL & BOUGHT OUT ITEMS													
1.1	Shell Plate SA 515 Gr 70 OR As per Drawing	Physical & Chemical, Heat Treatment if applicable,	MAJOR	Review of T.C	1/ HEAT	1/ HEAT	ASME SA 515 Gr 70 or Material Specification	TC	v	P	V	V	
		NDE		UT on Plate thickness >25 mm and = 25 mm.	100%	100%	ASTM A 435	TC	v	P	V	V	
1.2	Dished Ends SA 515 Gr 70 OR As per Drawing	Physical & Chemical, Heat Treatment if applicable,	MAJOR	Review of T.C	1/ HEAT	1/ HEAT	ASME SA 515 Gr 70 or Material Specification	TC	v	P	V	V	
1.3		NDE	MAJOR	UT on Plate thickness >25 mm and = 25 mm.	100%	100%	ASTM A 435	TC	v	P	V	V	
1.4		<u>DIMENSION</u> Outside Diameter Including Circumference, Knuckle Height ,Total height, Ovality, Profile (Crown, Knuckle,	MAJOR	Measurement	100%	100%	Approved Drawing	HC	v	P	W	V	

<p>LEGEND: P: PERFORM, W: WITNESS, V: VERIFICATION. INDICATE "C" FOR BHEL/<del>BHEL-NOMINATED INSPECTION AGENCY</del>, "N" END CUSTOMER/CONSULTANT &amp; "M" FOR VENDOR/SUB VENDOR AS APPROPRIATE AGAINST EACH COMPONENT /CHARACTERISTIC UNDER P, W &amp; V COLUMNS. <del>*FOR ITEMS MARKED ✓ (TICK) IN COLUMN "D", TEST CERTIFICATES SHALL BE SUBMITTED TO BHEL FOR RECORDS.</del></p> <p>*Records identified with "TICK"- ✓ shall be essentially included by supplier in QA Documentation.</p>	<p>PREPARED BY</p> <p style="text-align: center;">             BHEL QA         </p>	<p>APPROVED BY</p> <p style="text-align: center;">             BHEL QA         </p>	<p>APPROVED BY</p> <p style="text-align: center;">CUSTOMER'S</p>
--	--	--	--

	<b>STANDARD MANUFACTURING QUALITY PLAN</b>				QP. NO.: PESD/QA/TANK /1/25-26			
	<b>PROJECT ENGINEERING &amp; SYSTEMS DIVISION</b> BHEL-HYD 502032		PRODUCT : TANKS & VESSELS PROJECT: MPPGCL AMARKANTAK		REV NO: 00		DATE: 05.02.2026	
					PAGE 2 OF 6			

SL. NO	COMPONENT & OPERATIONS	CHARACTERISTICS	CLASS	CLASS TYPE OF CHECK	QUANTUM OF CHECK		REFERENCE DOCUMENT	ACCEPTANCE NORMS	FORMAT OF RECORD		AGENCY			REMARKS
					M	C / N				D*	M	C	N	
1	2	3	4	5	6		7	8	9	D*	** 10			11



		Straight Face) Minimum Thickness at Knuckle area by "D" meter												
1.5		<u>HEAT TREATMENT</u> Material Condition and verification of HT Chart.	MAJOR	Verification	100%	100%	ASME SA 515 Gr 70 or Material Specification	HT Report	√	P	V	V		
1.6		<u>SURFACE CHECK AFTER HT</u> Visual Check, NDE on Knuckle Area. Edge Preparation	MAJOR	Visual  LPI	100%	10%	ASME Sec.V Article 9 Clause T-940 /No crack ASME Sec V Article 6/ASME	H C  NDE Report	- √	P P	W W	- V		
1.7	Branch Connection SA 106 Gr B SA 105 for Nozzle & Stubs SA 672 Gr B 60 with flange for Manhole & drain or as per drawings	Chemical & Mechanical Properties	MAJOR	Review of TC as per specification	100%	100%	As per Specification/BHEL approved drawings.	TC	√	P	V	V		
		Hydraulic Test for Pipes.		Review of TC as per specification	100%	100%	ASME SA 530/BHEL Approved drawing/Relevant standard	TC	√	P	V	V		

<p>LEGEND: P: PERFORM, W: WITNESS, V: VERIFICATION. INDICATE "C" FOR BHEL/<del>BHEL NOMINATED INSPECTION AGENCY</del>, "N" END CUSTOMER/CONSULTANT &amp; "M" FOR VENDOR/SUB VENDOR AS APPROPRIATE AGAINST EACH COMPONENT /CHARACTERISTIC UNDER P, W &amp; V COLUMNS. *<del>FOR ITEMS MARKED ✓ (TICK) IN COLUMN 'D', TEST CERTIFICATES SHALL BE SUBMITTED TO BHEL FOR RECORDS.</del></p> <p>*Records identified with "TICK"- ✓ shall be essentially included by supplier in QA Documentation.</p>	PREPARED BY   BHEL QA	APPROVED BY   BHEL QA	APPROVED BY  CUSTOMER'S
--	---	---	-------------------------------

	<b>STANDARD MANUFACTURING QUALITY PLAN</b>				QP. NO.: PESD/QA/TANK /1/25-26			
	<b>PROJECT ENGINEERING &amp; SYSTEMS DIVISION</b> BHEL-HYD 502032		PRODUCT : TANKS & VESSELS PROJECT: MPPGCL AMARKANTAK		REV NO: 00		DATE: 05.02.2026	
					PAGE 3 OF 6			

SL. NO	COMPONENT & OPERATIONS	CHARACTERISTICS	CLASS	CLASS TYPE OF CHECK	QUANTUM OF CHECK		REFERENCE DOCUMENT	ACCEPTANCE NORMS	FORMAT OF RECORD		AGENCY			REMARKS
					M	C / N					M	C	N	
1	2	3	4	5	6		7	8	9	D*	** 10			11

1.8	Fasteners	Chemical & Mechanical Properties	MAJOR	Review of TC as per specification	100%	100%	As per Specification/BHEL approved drawings	TC	√	P	V	V	
1.9	Gasket	Material/Size	MAJOR	Review of TC as per specification	100%	100%	As per Specification/BHEL approved drawings	TC	√	P	V	V	
1.10	Electrodes	Chemical & Mechanical Properties	MAJOR	Correlation	100%	100%	As per Specification/BHEL approved drawings	Batch Certificate	√	P	V	V	
1.11	Paints	Catalogue	MAJOR	Correlation	100%	100%	As per Specification/BHEL approved drawings	Batch Certificate	√	P	V	V	
<b>2.0</b>	<b>IN PROCESS INSPECTION</b>												
2.1	Welding Procedure Qualification and Welders Performance Qualification	Procedure, Performance Qualification (Only Qualified Welders and WPS Shall be employed)	MAJOR	Review of WPS,PQR & WPQ	100%	100%	ASME Sec IX	WPS PQR WPQ		P	V	V	



<p>LEGEND: P: PERFORM, W: WITNESS, V: VERIFICATION. INDICATE "C" FOR BHEL/<del>BHEL Nominated Inspection Agency</del>, "N" END CUSTOMER/CONSULTANT &amp; "M" FOR VENDOR/SUB VENDOR AS APPROPRIATE AGAINST EACH COMPONENT /CHARACTERISTIC UNDER P, W &amp; V COLUMNS. <del>*FOR ITEMS MARKED ✓ (TICK) IN COLUMN 'D', TEST CERTIFICATES SHALL BE SUBMITTED TO BHEL FOR RECORDS.</del></p> <p><i>*Records identified with "TICK"- ✓ shall be essentially included by supplier in QA Documentation.</i></p>	PREPARED BY   BHEL QA	APPROVED BY   BHEL QA	APPROVED BY  CUSTOMER'S
---	---	---	-------------------------------

	<b>STANDARD MANUFACTURING QUALITY PLAN</b>				QP. NO.: PESD/QA/TANK /1/25-26			
	<b>PROJECT ENGINEERING &amp; SYSTEMS DIVISION</b> BHEL-HYD 502032		PRODUCT : TANKS & VESSELS PROJECT: MPPGCL AMARKANTAK		REV NO: 00		DATE: 05.02.2026	
					PAGE 4 OF 6			

SL. NO	COMPONENT & OPERATIONS	CHARACTERISTICS	CLASS	CLASS TYPE OF CHECK	QUANTUM OF CHECK		REFERENCE DOCUMENT	ACCEPTANCE NORMS	FORMAT OF RECORD		AGENCY			REMARKS
					M	C/N				D*	M	C	N	
1	2	3	4	5	6		7	8	9	D*	** 10			11

2.2	Weld Inspection	NDE Edge preparation	MAJOR	LPI	100%	10%	ASME Sec V/ ASME Sec VIII Division 1 Appendix-8	NDE Report	√	P	W	V	
2.3		Weld Edge Preparation & Fit up	Major	Visual & Measurement	100%	10%	BHEL Approved drawing/ ASME Sec VIII UW 31-33	IR	√	P	V	-	
2.4		Surface Discontinuities	Major	Visual	100%	10%	ASME Sec VIII/No Crack	IR	√	P	w	-	
2.5	Weld Inspection	Fillet Size	Major	Measurement	100%	10%	BHEL Approved Drawing	IR	√	P	w	-	
2.6		NDE on Butt Weld	Major	RT Film Review	Refer remarks	Refer remarks	ASME Sec V/ASME Sec VIII Div I Appendix-4	RT Report	√	P	w	v	<p>Circumferential seam 10% with 100% T Joints. Longitudinal seam 100% .All RT films shall be reviewed by BHEL TPIA and End Client</p>



reviewed by BHEL and End Client/NTPC.

<p>LEGEND: P: PERFORM, W: WITNESS, V: VERIFICATION. INDICATE "C" FOR BHEL/<del>BHEL-NOMINATED INSPECTION AGENCY</del>, "N" END CUSTOMER/CONSULTANT &amp; "M" FOR VENDOR/SUB VENDOR AS APPROPRIATE AGAINST EACH COMPONENT /CHARACTERISTIC UNDER P, W &amp; V COLUMNS. <del>*FOR ITEMS MARKED ✓ (TICK) IN COLUMN "D", TEST CERTIFICATES SHALL BE SUBMITTED TO BHEL FOR RECORDS.</del></p> <p>*Records identified with "TICK"- ✓ shall be essentially included by supplier in QA Documentation.</p>	<p>PREPARED BY</p>  <p>BHEL QA</p>	<p>APPROVED BY</p>  <p>BHEL QA</p>	<p>APPROVED BY</p> <p>CUSTOMER'S</p>
--	---	---	--------------------------------------

	<b>STANDARD MANUFACTURING QUALITY PLAN</b>				QP. NO.: PESD/QA/TANK /1/25-26			
	<b>PROJECT ENGINEERING &amp; SYSTEMS DIVISION</b> BHEL-HYD 502032		PRODUCT : TANKS & VESSELS PROJECT: MPPGCL AMARKANTAK		REV NO: 00		DATE: 05.02.2026	
					PAGE 5 OF 6			

SL. NO	COMPONENT & OPERATIONS	CHARACTERISTICS	CLASS	CLASS TYPE OF CHECK	QUANTUM OF CHECK		REFERENCE DOCUMENT	ACCEPTANCE NORMS	FORMAT OF RECORD		AGENCY			REMARKS
					M	C / N				D*	M	C	N	
1	2	3	4	5	6		7	8	9	D*	** 10			11

2.7		Butt Welds & Fillet Welds	Major	LPI	100%	100%	ASME Sec V/ ASME Sec VIII Division 1 Appendix-8	NDT Report	√	P	w	v		
<b>3.0 FINAL INSPECTION</b>														
3.1	TANK Dimension	Overall Dimension Length ,OD Orientation & location of stubs, nozzle etc.	Major	Measurement	100%	100%	BHEL Approved Drawing/Specification	Inspection Report	√	P	w	w		
3.2	Reinforcement Pads.	Pneumatic Test	Major	Soap Solution Test	100%	100%	BHEL Approved Drawing/No leakage	Inspection Report	√	P	w	w		
3.3	Tank Pressure Test	Strength and Leak tightness	Critical	Hydrotest	100%	100%	BHEL Approved Drawing/No leakage at 1.5 times design pressure	Inspection Report	√	P	w	w		
3.4	Identification	Punching	Major	Visual Check	100%	100%	Purchase Order, DU number, etc as per Specification.	Inspection Report	√	P	w	v		

<p>LEGEND: P: PERFORM, W: WITNESS, V: VERIFICATION. INDICATE "C" FOR BHEL/BHEL NOMINATED INSPECTION AGENCY, "N" END CUSTOMER/CONSULTANT &amp; "M" FOR VENDOR/SUB VENDOR AS APPROPRIATE AGAINST EACH COMPONENT /CHARACTERISTIC UNDER P, W &amp; V COLUMNS. *FOR ITEMS MARKED ✓ (TICK) IN COLUMN "D", TEST CERTIFICATES SHALL BE SUBMITTED TO BHEL FOR RECORDS.</p> <p>*Records identified with "TICK"- ✓ shall be essentially included by supplier in QA Documentation.</p>	<p>PREPARED BY</p>  <p>BHEL QA</p>	<p>APPROVED BY</p>  <p>BHEL QA</p>	<p>APPROVED BY</p> <p>CUSTOMER'S</p>
--	---	---	--------------------------------------



	<b>STANDARD MANUFACTURING QUALITY PLAN</b>				QP. NO.: PESD/QA/TANK /1/25-26				
	<b>PROJECT ENGINEERING &amp; SYSTEMS DIVISION</b> BHEL-HYD 502032		PRODUCT : TANKS & VESSELS PROJECT: MPPGCL AMARKANTAK		REV NO: 00		DATE: 05.02.2026		
PAGE 6 OF 6									

SL. NO	COMPONENT & OPERATIONS	CHARACTERISTICS	CLASS	CLASS TYPE OF CHECK	QUANTUM OF CHECK		REFERENCE DOCUMENT	ACCEPTANCE NORMS	FORMAT OF RECORD		AGENCY			REMARKS
					M	C / N				D*	M	C	N	
1	2	3	4	5	6		7	8	9	D*	** 10			11

3.5		Surface preparation, Painting, Stenciling and Packing	Major	Visual Check	100%	100%	Approved Painting Specification <i>Shall be approved by NTPC-Engg.</i>	Inspection Report	√	P	w	v	
-----	--	---	-------	--------------	------	------	---	-------------------	---	---	---	---	--

**NOTE:**

1. This standard MQP should be read along with specification (latest revision), approved drawings & approved data sheet.
2. Specification/drawing/data sheet shall prevail over quality plan for contradiction if any between Quality plan and drawing/specification.
3. All test certificates/reports reviewed and certified by TPI/BHEL shall be submitted to BHEL as documentation package.
4. Welding shall be done as per WPS and Drawing requirement, full penetration shall be ensured for all nozzle welds.
5. All lab reports shall be from NABL accredited lab.
6. All materials shall be procured from approved sources.

LEGEND: P: PERFORM, W: WITNESS, V: VERIFICATION. INDICATE "C" FOR BHEL/BHEL Nominated Inspection Agency, "N" END CUSTOMER/CONSULTANT & "M" FOR VENDOR/SUB VENDOR AS APPROPRIATE AGAINST EACH COMPONENT /CHARACTERISTIC UNDER P, W & V COLUMNS. *FOR ITEMS MARKED ✓ (TICK) IN COLUMN 'D', TEST CERTIFICATES SHALL BE SUBMITTED TO BHEL FOR RECORDS. <i>*Records identified with "TICK"- ✓ shall be essentially included by supplier in QA Documentation.</i>	PREPARED BY   BHEL QA	APPROVED BY   BHEL QA	APPROVED BY  CUSTOMER'S
--	---	---	-------------------------------



A Maharatna Company

एन टी पी सी लिमिटेड

(भारत सरकार का उद्यम)

NTPC Limited

(A Govt. of India Enterprise)

(Formerly National Thermal Power Corporation Ltd.)

(केंद्रीय कार्यालय नोएडा)

Corporate Center NOIDA

Reference : CC-ENGG-1233-001-102-QVM-Q-001

Date : 14/05/2026

<b>From :</b> SUSHANTA BHUYAN SENIOR MANAGER	<b>To :</b> BHEL DELHI SIRIFORT, BHEL HOUSE,P.S.PROJECT MANAGEMENT GRP BHEL NEW DELHI 110049
<b>Cc :</b>	
<b>Subject :</b> EPC Package for 1X660 MW Ultra Super critical Unit#12 at Satpura TPS, Sarni. Please find enclosed following drawings/ documents for necessary action at your end.	
<b>Vendor Drg. No. :</b> PESD/QA/TANK/1/25-26 <b>Orgn. Drg. No. :</b> 1233-001-102-QVM-Q-001 <b>Revision No. :</b> 00 <b>Drg. Title :</b> QAP FOR TANK AND VESSELS <b>App. Category :</b> CAT-I <b>Release Date :</b> 14/05/2026	 Scan to verify
<b>Comments :</b> Approved in CAT-I with comments	



Engineering Division  
ISO 9001:2008 Certified



अभियंत्रिकी कार्यालय परिसर, प्लॉट नं.- ए 8ए, सेक्टर-24, पोस्ट बॉक्स नं.- 13, नोएडा (उ.प्र.) पिन-201 307

टेलिफोन नं.- 0120-2410333, 2410116 फैक्स-0120-2410136, 2410137

पंजीकृत कार्यालय: एनटीपीसी भवन, स्कोप कॉम्प्लेक्स, 7 इंस्टीट्यूशनल एरिया, लोधी रोड, नई दिल्ली-110 003

टेलिफोन नं.- 011-24361018 फैक्स-011-24361018, वेबसाइट: www.ntpc.co.in

ENGINEERING OFFICE COMPLEX, Plot No: A-SA, Sector-24, Post Box No: 13, Noida (UP), Pin-201 307

Telephone No: 0120-2410333, 2410116 Fax-0120-2410136, 2410137

Registered Office: NTPC Bhawan, Scope Complex, 7 Institutional Area, Lodhi Road, New Delhi-110 003

Telephone No: 011 24360100 Fax: 011 24361018, Website: www.ntpc.co.in



## MPPGCL SATPURA

TITLE OF THE DRAWING / DOCUMENT	QAP FOR TANKS AND VESSELS
BHEL DRG NO	PESD/QA/TANK /1/25-26

This Std. MQP is applicable for SG area - Low Pressure Tanks and vessels.



0	24-04-2026	FOR APPROVAL	AKN		AKN		AKN	Sd
REV NO.	DATE	STATUS	INITIALS	SIGN	INITIALS	SIGN	INITIALS	SIGN
			PRPD. BY		CHKD. BY		APPRD. BY	
PROJECT: MPPGCL SATPURA							REV 0	
							Date: 24-04-2026	Page 1 of 1

	<b>STANDARD MANUFACTURING QUALITY PLAN</b>				QP. NO.: PESD/QA/TANK /1/25-26			
	<b>PROJECT ENGINEERING &amp; SYSTEMS DIVISION</b> BHEL-HYD 502032		PRODUCT : TANKS & VESSELS PROJECT: MPPGCL SATPURA		REV NO: 00		DATE: 05.02.2026	
					PAGE 1 OF 6			

SL. NO	COMPONENT & OPERATIONS	CHARACTERISTICS	CLASS	CLASS TYPE OF CHECK	QUANTUM OF CHECK		REFERENCE DOCUMENT	ACCEPTANCE NORMS	FORMAT OF RECORD		AGENCY			REMARKS
					M	C / N				D*	M	C	N	
1	2	3	4	5	6		7	8	9	D*	** 10			11

1.0 RAW MATERIAL & BOUGHT OUT ITEMS													
1.1	Shell Plate SA 515 Gr 70 OR As per Drawing	Physical & Chemical, Heat Treatment if applicable,	MAJOR	Review of T.C	1/ HEAT	1/ HEAT	ASME SA 515 Gr 70 or Material Specification	TC	v	P	V	V	
		NDE		UT on Plate thickness >25 mm and = 25 mm.	100%	100%	ASTM A 435	TC	v	P	V	V	
1.2	Dished Ends SA 515 Gr 70 OR As per Drawing	Physical & Chemical, Heat Treatment if applicable,	MAJOR	Review of T.C	1/ HEAT	1/ HEAT	ASME SA 515 Gr 70 or Material Specification	TC	v	P	V	V	
1.3		NDE	MAJOR	UT on Plate thickness >25 mm and = 25 mm.	100%	100%	ASTM A 435	TC	v	P	V	V	
1.4		<u>DIMENSION</u> Outside Diameter Including Circumference, Knuckle Height ,Total height, Ovality, Profile (Crown, Knuckle,	MAJOR	Measurement	100%	100%	Approved Drawing	HC	v	P	W	V	

LEGEND: P: PERFORM, W: WITNESS, V: VERIFICATION. INDICATE "C" FOR BHEL/BHEL Nominated Inspection Agency, "N" END CUSTOMER/CONSULTANT & "M" FOR VENDOR/SUB VENDOR AS APPROPRIATE AGAINST EACH COMPONENT /CHARACTERISTIC UNDER P, W & V COLUMNS. \* FOR ITEMS MARKED ✓ (TICK) IN COLUMN 'D', TEST CERTIFICATES SHALL BE SUBMITTED TO BHEL FOR RECORDS.

\*Records identified with "TICK"- ✓ shall be essentially included by supplier in QA Documentation.

PREPARED BY

BHEL QA



APPROVED BY

BHEL QA





APPROVED BY

CUSTOMER'S

	<b>STANDARD MANUFACTURING QUALITY PLAN</b>				QP. NO.: PESD/QA/TANK /1/25-26			
	<b>PROJECT ENGINEERING &amp; SYSTEMS DIVISION</b> BHEL-HYD 502032		PRODUCT : TANKS & VESSELS PROJECT: MPPGCL SATPURA		REV NO: 00		DATE: 05.02.2026	
					PAGE 2 OF 6			

SL. NO	COMPONENT & OPERATIONS	CHARACTERISTICS	CLASS	CLASS TYPE OF CHECK	QUANTUM OF CHECK		REFERENCE DOCUMENT	ACCEPTANCE NORMS	FORMAT OF RECORD		AGENCY			REMARKS
					M	C / N				D*	M	C	N	
1	2	3	4	5	6		7	8	9	D*	** 10	11		



		Straight Face) Minimum Thickness at Knuckle area by "D" meter												
1.5		<u>HEAT TREATMENT</u> Material Condition and verification of HT Chart.	MAJOR	Verification	100%	100%	ASME SA 515 Gr 70 or Material Specification	HT Report	√	P	V	V		
1.6		<u>SURFACE CHECK AFTER HT</u> Visual Check, NDE on Knuckle Area. Edge Preparation	MAJOR	Visual  LPI	100%	10%	ASME Sec.V Article 9 Clause T-940 /No crack ASME Sec V Article 6/ASME	H C  NDE Report	- √	P P	W W	- V		
1.7	Branch Connection SA 106 Gr B SA 105 for Nozzle & Stubs SA 672 Gr B 60 with flange for Manhole & drain or as per drawings	Chemical & Mechanical Properties	MAJOR	Review of TC as per specification	100%	100%	As per Specification/BHEL approved drawings.	TC	√	P	V	V		
		Hydraulic Test for Pipes.		Review of TC as per specification	100%	100%	ASME SA 530/BHEL Approved drawing/Relevant standard	TC	√	P	V	V		

<p>LEGEND: P: PERFORM, W: WITNESS, V: VERIFICATION. INDICATE "C" FOR BHEL/BHEL Nominated Inspection Agency, "N" END CUSTOMER/CONSULTANT &amp; "M" FOR VENDOR/SUB VENDOR AS APPROPRIATE AGAINST EACH COMPONENT /CHARACTERISTIC UNDER P, W &amp; V COLUMNS. *FOR ITEMS MARKED ✓ (TICK) IN COLUMN 'D', TEST CERTIFICATES SHALL BE SUBMITTED TO BHEL FOR RECORDS.</p> <p>*Records identified with "TICK"- ✓ shall be essentially included by supplier in QA Documentation.</p>	PREPARED BY	APPROVED BY	APPROVED BY
	BHEL QA		

	<b>STANDARD MANUFACTURING QUALITY PLAN</b>				QP. NO.: PESD/QA/TANK /1/25-26			
	<b>PROJECT ENGINEERING &amp; SYSTEMS DIVISION</b> BHEL-HYD 502032		PRODUCT : TANKS & VESSELS PROJECT: MPPGCL SATPURA		REV NO: 00		DATE: 05.02.2026	
					PAGE 3 OF 6			

SL. NO	COMPONENT & OPERATIONS	CHARACTERISTICS	CLASS	CLASS TYPE OF CHECK	QUANTUM OF CHECK		REFERENCE DOCUMENT	ACCEPTANCE NORMS	FORMAT OF RECORD		AGENCY			REMARKS
					M	C / N				D*	M	C	N	
1	2	3	4	5	6		7	8	9		** 10			11

1.8	Fasteners	Chemical & Mechanical Properties	MAJOR	Review of TC as per specification	100%	100%	As per Specification/BHEL approved drawings	TC	√	P	V	V	
1.9	Gasket	Material/Size	MAJOR	Review of TC as per specification	100%	100%	As per Specification/BHEL approved drawings	TC	√	P	V	V	
1.10	Electrodes	Chemical & Mechanical Properties	MAJOR	Correlation	100%	100%	As per Specification/BHEL approved drawings	Batch Certificate	√	P	V	V	
1.11	Paints	Catalogue	MAJOR	Correlation	100%	100%	As per Specification/BHEL approved drawings	Batch Certificate	√	P	V	V	
<b>2.0</b>	<b>IN PROCESS INSPECTION</b>												
2.1	Welding Procedure Qualification and Welders Performance Qualification	Procedure, Performance Qualification (Only Qualified Welders and WPS Shall be employed)	MAJOR	Review of WPS,PQR & WPQ	100%	100%	ASME Sec IX	WPS PQR WPQ		P	V	V	

<p>LEGEND: P: PERFORM, W: WITNESS, V: VERIFICATION. INDICATE "C" FOR BHEL/BHEL NOMINATED INSPECTION AGENCY, "N" END CUSTOMER/CONSULTANT &amp; "M" FOR VENDOR/SUB VENDOR AS APPROPRIATE AGAINST EACH COMPONENT /CHARACTERISTIC UNDER P, W &amp; V COLUMNS. *FOR ITEMS MARKED ✓ (TICK) IN COLUMN 'D', TEST CERTIFICATES SHALL BE SUBMITTED TO BHEL FOR RECORDS.</p> <p>*Records identified with "TICK"-✓ shall be essentially included by supplier in QA Documentation.</p>	PREPARED BY	APPROVED BY	APPROVED BY
	BHEL QA		



	<b>STANDARD MANUFACTURING QUALITY PLAN</b>		QP. NO.: PESD/QA/TANK /1/25-26	
	<b>PROJECT ENGINEERING &amp; SYSTEMS DIVISION</b> BHEL-HYD 502032	PRODUCT : TANKS & VESSELS PROJECT: MPPGCL SATPURA	REV NO: 00	DATE: 05.02.2026
PAGE 4 OF 6				

SL. NO	COMPONENT & OPERATIONS	CHARACTERISTICS	CLASS	CLASS TYPE OF CHECK	QUANTUM OF CHECK		REFERENCE DOCUMENT	ACCEPTANCE NORMS	FORMAT OF RECORD		AGENCY			REMARKS
					M	C/N				D*	M	C	N	
1	2	3	4	5	6		7	8	9	D*	** 10			11

2.2	Weld Inspection	NDE Edge preparation	MAJOR	LPI	100%	10%	ASME Sec V/ ASME Sec VIII Division 1 Appendix-8	NDE Report	√	P	W	V	
2.3		Weld Edge Preparation & Fit up	Major	Visual & Measurement	100%	10%	BHEL Approved drawing/ ASME Sec VIII UW 31-33	IR	√	P	V	-	
2.4		Surface Discontinuities	Major	Visual	100%	10%	ASME Sec VIII/No Crack	IR	√	P	w	-	
2.5	Weld Inspection	Fillet Size	Major	Measurement	100%	10%	BHEL Approved Drawing	IR	√	P	w	-	
2.6		NDE on Butt Weld	Major	RT Film Review	Refer remarks	Refer remarks	ASME Sec V/ASME Sec VIII Div I Appendix-4	RT Report	√	P	w	v	

Circumferential seam 10% with 100% T Joints. Longitudinal seam 100% .All RT films shall be reviewed by BHEL TPIA and End Client

reviewed by BHEL and End Client/NTPC.

<p>LEGEND: P: PERFORM, W: WITNESS, V: VERIFICATION. INDICATE "C" FOR BHEL/<del>BHEL NOMINATED INSPECTION AGENCY</del>, "N" END CUSTOMER/CONSULTANT &amp; "M" FOR VENDOR/SUB VENDOR AS APPROPRIATE AGAINST EACH COMPONENT /CHARACTERISTIC UNDER P, W &amp; V COLUMNS. * <del>FOR ITEMS MARKED ✓ (TICK) IN COLUMN 'D', TEST CERTIFICATES SHALL BE SUBMITTED TO BHEL FOR RECORDS.</del></p> <p>*Records identified with "TICK"- ✓ shall be essentially included by supplier in QA Documentation.</p>	PREPARED BY	APPROVED BY	APPROVED BY
	BHEL QA		

	<b>STANDARD MANUFACTURING QUALITY PLAN</b>				QP. NO.: PESD/QA/TANK /1/25-26			
	<b>PROJECT ENGINEERING &amp; SYSTEMS DIVISION</b> BHEL-HYD 502032		PRODUCT : TANKS & VESSELS PROJECT: MPPGCL SATPURA		REV NO: 00		DATE: 05.02.2026	
					PAGE 5 OF 6			

SL. NO	COMPONENT & OPERATIONS	CHARACTERISTICS	CLASS	CLASS TYPE OF CHECK	QUANTUM OF CHECK		REFERENCE DOCUMENT	ACCEPTANCE NORMS	FORMAT OF RECORD		AGENCY			REMARKS
					M	C / N				D*	M	C	N	
1	2	3	4	5	6		7	8	9	D*	** 10			11

2.7		Butt Welds & Fillet Welds	Major	LPI	100%	100%	ASME Sec V/ ASME Sec VIII Division 1 Appendix-8	NDT Report	√	P	w	v		
<b>3.0</b>	<b>FINAL INSPECTION</b>													
3.1	TANK Dimension	Overall Dimension Length ,OD Orientation & location of stubs,nozzle etc.	Major	Measurement	100%	100%	BHEL Approved Drawing/Specification	Inspection Report	√	P	w	w		
3.2	Reinforcement Pads.	Pneumatic Test	Major	Soap Solution Test	100%	100%	BHEL Approved Drawing/No leakage	Inspection Report	√	P	w	w		
3.3	Tank Pressure Test	Strength and Leak tightness	Critical	Hydrotest	100%	100%	BHEL Approved Drawing/No leakage at 1.5 times design pressure	Inspection Report	√	P	w	w		
3.4	Identification	Punching	Major	Visual Check	100%	100%	Purchase Order,DU number,etc as per Specification.	Inspection Report	√	P	w	v		

LEGEND: P: PERFORM, W: WITNESS, V: VERIFICATION. INDICATE "C" FOR BHEL/BHEL Nominated Inspection Agency, "N" END CUSTOMER/CONSULTANT & "M" FOR VENDOR/SUB VENDOR AS APPROPRIATE AGAINST EACH COMPONENT /CHARACTERISTIC UNDER P, W & V COLUMNS. \*FOR ITEMS MARKED ✓ (TICK) IN COLUMN "D", TEST CERTIFICATES SHALL BE SUBMITTED TO BHEL FOR RECORDS.

\*Records identified with "TICK"- ✓ shall be essentially included by supplier in QA Documentation.

PREPARED BY

BHEL QA



APPROVED BY

BHEL QA



APPROVED BY

CUSTOMER'S



	<b>STANDARD MANUFACTURING QUALITY PLAN</b>				QP. NO.: PESD/QA/TANK /1/25-26			
	<b>PROJECT ENGINEERING &amp; SYSTEMS DIVISION</b> BHEL-HYD 502032		PRODUCT : TANKS & VESSELS PROJECT: MPPGCL SATPURA		REV NO: 00		DATE: 05.02.2026	
					PAGE 6 OF 6			

SL. NO	COMPONENT & OPERATIONS	CHARACTERISTICS	CLASS	CLASS TYPE OF CHECK	QUANTUM OF CHECK		REFERENCE DOCUMENT	ACCEPTANCE NORMS	FORMAT OF RECORD		AGENCY			REMARKS
					M	C / N				D*	M	C	N	
1	2	3	4	5	6		7	8	9	D*	** 10	11		

3.5		Surface preparation, Painting, Stenciling and Packing	Major	Visual Check	100%	100%	Approved Painting Specification <i>Shall be approved by NTPC-Engg.</i>	Inspection Report	√	P	w	v	
-----	--	---	-------	--------------	------	------	---	-------------------	---	---	---	---	--

**NOTE:**

1. This standard MQP should be read along with specification (latest revision), approved drawings & approved data sheet.
2. Specification/drawing/data sheet shall prevail over quality plan for contradiction if any between Quality plan and drawing/specification.
3. All test certificates/reports reviewed and certified by ~~TPI~~/BHEL shall be submitted to BHEL as documentation package.
4. Welding shall be done as per WPS and Drawing requirement, full penetration shall be ensured for all nozzle welds.
5. All lab reports shall be from NABL accredited lab.
6. All materials shall be procured from approved sources.

LEGEND: P: PERFORM, W: WITNESS, V: VERIFICATION. INDICATE "C" FOR BHEL/ <del>BHEL Nominated Inspection Agency</del> , "N" END CUSTOMER/CONSULTANT & "M" FOR VENDOR/SUB VENDOR AS APPROPRIATE AGAINST EACH COMPONENT /CHARACTERISTIC UNDER P, W & V COLUMNS. * <del>FOR ITEMS MARKED ✓ (TICK) IN COLUMN 'D', TEST CERTIFICATES SHALL BE SUBMITTED TO BHEL FOR RECORDS.</del> <i>*Records identified with "TICK"- ✓ shall be essentially included by supplier in QA Documentation.</i>	PREPARED BY	APPROVED BY	APPROVED BY
	BHEL QA		



**MANUFACTURER'S NAME & ADDRESS**  
**BHEL: VISAKHAPATNAM**  
**APPROVED VENDOR**

## STANDARD QUALITY PLAN

**ITEM: DISHED ENDS OF COLUMNS & PRESSURE VESSELS**

**BHEL SPECIFICATION: HPV: DG: ENGG: 031**

**QP NO.: SQP: H: PP:29**  
**REV.NO.01 DATE: 02.04.2026**  
**PAGE: 2 OF 7**

SL. NO.	COMPONENT & OPERATIONS	CHARACTERISTICS	CLASS	TYPE OF CHECK	QUANTUM OF CHECK		REFERENCE DOCUMENT	ACCEPTANCE NORMS	FORMAT OF RECORD		AGENCY			REMARKS
					B	C					M	B	C	
1	2	3	4	5	6	7	8	9	D*	**	10	11		

<b>1.0</b>	<b>RAW MATERIAL:</b>												
1.1	Plates	Physical condition, Chemical & Mechanical Properties, Heat No, UT	MA	Verification & Correlation of Material Spec. & MTC	100%	TDC & Material Specification	MTC	√	P	V			
<b>2.0</b>	<b>IN PROCESS CONTROL:</b>												
2.1	Material identification	Heat No, Plate No, Grade etc.,	MA	Transfer of Marking and Heat Number	100%	Drawing & TDC	IR		P	V			Refer Note-3
2.2	Welding qualifications	Procedure Qualification, Personnel Qualification	MA	WPS, PQR review WQR review	100%	ASME Sec IX	ASME Format	√	P	W/V			W- for new WPS V- Old WPS
2.3	Weld Edge Preparation & NDE (if applicable)	Bevel angle, Surface finish, Detection of flaws	MA	Visual, Measurement, LPI	100%	Drawing/LPI Procedure	IR	√	P	V			

**LEGEND:** RECORDS, IDENTIFIED WITH "TICK" (√) AGAINST "D" SHALL BE ESSENTIALLY INCLUDED BY SUPPLIER IN FINAL DOCUMENTATION.  
**\*\* M:** MANUFACTURER **B:** BHEL QC / BHEL AUTHORISED INSPECTION AGENCY **C:** CUSTOMER **P:** PERFORM. **W:** WITNESS. **V:** VERIFICATION OF DOCUMENTS CLASS : **CR** - CRITICAL; **MA** - MAJOR; **MI** - MINOR; **MTC**- MILL /MANUFACTURER'S TEST CERTIFICATE; **TDC:** TECHNICAL DELIVERY CONDITIONS **IR** – INSPECTION/TEST REPORT;  
**WPS:** WELDING PROCEDURE SPECIFICATION **PQR:** PROCEDURE QUALIFICATION RECORD **WQR:** WELDER QUALIFICATION RECORD **HT:** HEAT TREATMENT **PFHT:** POST FORMING HEAT TREATMENT; **NDE:** NON DESTRUCTIVE EXAMINATION **LPI:** LIQUID PENETRANT INSPECTION **MPI:** MAGNETIC PARTICLE INSPECTION **RT:** RADIOGRAPHIC TESTING **UT:** ULTRASONIC TESTING; **PTC:** PRODUCTION TEST COUPON



**MANUFACTURER'S NAME & ADDRESS**  
**BHEL: VISAKHAPATNAM**  
**APPROVED VENDOR**

## STANDARD QUALITY PLAN

**ITEM: DISHED ENDS OF COLUMNS & PRESSURE VESSELS**

**BHEL SPECIFICATION: HPVP: DG: ENGG: 031**

**QP NO.: SQP: H: PP:29**  
**REV.NO.01 DATE: 02.04.2026**  
**PAGE: 3 OF 7**

SL. NO.	COMPONENT & OPERATIONS	CHARACTERISTICS	CLASS	TYPE OF CHECK	QUANTUM OF CHECK		REFERENCE DOCUMENT	ACCEPTANCE NORMS	FORMAT OF RECORD		AGENCY			REMARKS
					B	C					M	B	C	
1	2	3	4	5	6	7	8	9	D*	**	10	11		

2.4	Fit up & Welding of L-Seam along with PTC as applicable (if weld is applicable)	Orientation, Dimensions, Weld soundness, PTC	MA	Visual, Measurement	100%	Drawing & ASME Sec VIII Div I	BHEL specification & Drawing	IR	√	P	V	
2.5	NDT on chipped back L-Seam weld before forming (if weld is applicable)	Weld soundness	MA	LPI	100%	Drawing & ASME Sec VIII Div I		LPI report	√	P	V	* RT film review Refer enclosed Appendix in case of Clad material
2.6			MA	RT	100%	Drawing & ASME Sec VIII Div I		RT report & RT Films	√	P	V*	
2.7	Forming of Dish End	Dimensions (including minimum thickness)	MA	Measurement, Template check	100%	BHEL specification & drawing		IR	√	P	V	Refer enclosed Appendix before forming in case of Clad material
2.8	NDT of L-Seam weld (if weld is applicable) after forming before heat treatment	Weld soundness	MA	RT	100%	Drawing & ASME Sec VIII Div I		RT report & RT Films	√	P	V*	*RT film review

**LEGEND:** RECORDS, IDENTIFIED WITH "TICK" (√) AGAINST "D" SHALL BE ESSENTIALLY INCLUDED BY SUPPLIER IN FINAL DOCUMENTATION.  
**\*\* M:** MANUFACTURER **B:** BHEL QC / BHEL AUTHORISED INSPECTION AGENCY **C:** CUSTOMER **P:** PERFORM. **W:** WITNESS. **V:** VERIFICATION OF DOCUMENTS CLASS : **CR** - CRITICAL; **MA** - MAJOR; **MI** - MINOR; **MTC**- MILL /MANUFACTURER'S TEST CERTIFICATE; **TDC:** TECHNICAL DELIVERY CONDITIONS **IR** – INSPECTION/TEST REPORT;  
**WPS:** WELDING PROCEDURE SPECIFICATION **PQR:** PROCEDURE QUALIFICATION RECORD **WQR:** WELDER QUALIFICATION RECORD **HT:** HEAT TREATMENT **PFHT:** POST FORMING HEAT TREATMENT; **NDE:** NON DESTRUCTIVE EXAMINATION **LPI:** LIQUID PENETRANT INSPECTION **MPI:** MAGNETIC PARTICLE INSPECTION **RT:** RADIOGRAPHIC TESTING **UT:** ULTRASONIC TESTING; **PTC:** PRODUCTION TEST COUPON



**MANUFACTURER'S NAME & ADDRESS**  
**BHEL: VISAKHAPATNAM**  
**APPROVED VENDOR**

## STANDARD QUALITY PLAN

**ITEM: DISHED ENDS OF COLUMNS & PRESSURE VESSELS**

**BHEL SPECIFICATION: HPVP: DG: ENGG: 031**

**QP NO.: SQP: H: PP:29**  
**REV.NO.01 DATE: 02.04.2026**  
**PAGE: 4 OF 7**

SL. NO.	COMPONENT & OPERATIONS	CHARACTERISTICS	CLASS	TYPE OF CHECK	QUANTUM OF CHECK		REFERENCE DOCUMENT	ACCEPTANCE NORMS	FORMAT OF RECORD		AGENCY			REMARKS
					B	C					M	B	C	
1	2	3	4	5	6	7	8	9	D*		**	10	11	

2.9	Post forming Heat Treatment (along with PTC) as applicable	Time & Temperature	MA	Review of HT charts	100%	As per HT instruction sheet provided by BHEL	HT Chart	√	P	V			
<b>3.0</b>	<b>FINAL INSPECTION</b>												
3.1	NDE on dished ends post forming heat treatment	Detection of flaws in Formed Head	MA	UT	100%	Drawing & ASME Sec VIII Div I	UT report	√	P	W			Refer enclosed Appendix before Final Inspection in case of Clad material Entire Knuckle area region (both inside & outside) & on welds  100% MPI for LAS materials
				LPI	As per remarks	Drawing & ASME Sec VIII Div I	LPI report	√	P	W			
				MPI	100%	Drawing & ASME Sec VIII Div I	MPI report	√	P	W			
3.3	Testing of PTC (as applicable)	Physical properties	MA	Destructive testing	100%	As per Drawing / Material Specification	IR	√	P	V			

**LEGEND:** RECORDS, IDENTIFIED WITH "TICK" (√) AGAINST "D" SHALL BE ESSENTIALLY INCLUDED BY SUPPLIER IN FINAL DOCUMENTATION.  
**\*\* M:** MANUFACTURER **B:** BHEL QC / BHEL AUTHORISED INSPECTION AGENCY **C:** CUSTOMER **P:** PERFORM. **W:** WITNESS. **V:** VERIFICATION OF DOCUMENTS CLASS : **CR** - CRITICAL; **MA** - MAJOR; **MI** - MINOR; **MTC**- MILL /MANUFACTURER'S TEST CERTIFICATE; **TDC:** TECHNICAL DELIVERY CONDITIONS **IR** – INSPECTION/TEST REPORT;  
**WPS:** WELDING PROCEDURE SPECIFICATION **PQR:** PROCEDURE QUALIFICATION RECORD **WQR:** WELDER QUALIFICATION RECORD **HT:** HEAT TREATMENT **PFHT:** POST FORMING HEAT TREATMENT; **NDE:** NON DESTRUCTIVE EXAMINATION **LPI:** LIQUID PENETRANT INSPECTION **MPI:** MAGNETIC PARTICLE INSPECTION **RT:** RADIOGRAPHIC TESTING **UT:** ULTRASONIC TESTING; **PTC:** PRODUCTION TEST COUPON



**MANUFACTURER'S NAME & ADDRESS**  
**BHEL: VISAKHAPATNAM**  
**APPROVED VENDOR**

## STANDARD QUALITY PLAN

**ITEM: DISHED ENDS OF COLUMNS & PRESSURE VESSELS**

**BHEL SPECIFICATION: HPVP: DG: ENGG: 031**

**QP NO.: SQP: H: PP:29**  
**REV.NO.01 DATE: 02.04.2026**  
**PAGE: 5 OF 7**

SL. NO.	COMPONENT & OPERATIONS	CHARACTERISTICS	CLASS	TYPE OF CHECK	QUANTUM OF CHECK		REFERENCE DOCUMENT	ACCEPTANCE NORMS	FORMAT OF RECORD		AGENCY			REMARKS
					B	C					M	B	C	
1	2	3	4	5	6		7	8	9	D*	** 10			11

3.4	Final Inspection	Minimum thickness, profile, ovality, Depth, Circumference etc.,	MA	Visual, Dimensional	100%		Drawing & ASME Sec VIII Div I	BHEL specification & Drawing	IR	√	P	W	Dimensional check including minimum thickness using UT or UT-D meter
3.5	Pickling & Passivation	Surface quality	MA	Visual	100%		Drawing		IR	√	P	V	For Alloy steel & Stainless steel only
3.6	Final Documentation	Compliance with Quality plan	MA	Verification	100%		As per PO		MRB	√	P	V	Refer Note-5

### NOTES:

- In case of conflict, more stringent requirement shall prevail.
- All the measuring instruments / equipment shall have valid calibration records as on the date of use, from NABL / equivalent accredited bodies.
- Transfer of identification mark on each part to be ensured before use.
- In case spinning method is adopted, the central hole shall be plugged and radiographed 100% and the RT films would be offered to BHEL TPIA.
- MRB shall comprise reports as per this QP and shall be prefixed with an Index sheet with page numbers.
- The latest revisions/year of issue of ASME/ASTM standards shall be referred.
- Products shall be inspected as per this SQP. Manufacturer shall prepare and submit a separate quality plan wherever BHEL's customer/customer TPIA inspection is envisaged (as specified in the BHEL purchase order).

**LEGEND:** RECORDS, IDENTIFIED WITH "TICK" (√) AGAINST "D" SHALL BE ESSENTIALLY INCLUDED BY SUPPLIER IN FINAL DOCUMENTATION.  
**\*\* M:** MANUFACTURER **B:** BHEL QC / BHEL AUTHORISED INSPECTION AGENCY **C:** CUSTOMER **P:** PERFORM. **W:** WITNESS. **V:** VERIFICATION OF DOCUMENTS CLASS : **CR** - CRITICAL; **MA** - MAJOR; **MI** - MINOR; **MTC** - MILL /MANUFACTURER'S TEST CERTIFICATE; **TDC:** TECHNICAL DELIVERY CONDITIONS **IR** - INSPECTION/TEST REPORT;  
**WPS:** WELDING PROCEDURE SPECIFICATION **PQR:** PROCEDURE QUALIFICATION RECORD **WQR:** WELDER QUALIFICATION RECORD **HT:** HEAT TREATMENT **PFHT:** POST FORMING HEAT TREATMENT; **NDE:** NON DESTRUCTIVE EXAMINATION **LPI:** LIQUID PENETRANT INSPECTION **MPI:** MAGNETIC PARTICLE INSPECTION **RT:** RADIOGRAPHIC TESTING **UT:** ULTRASONIC TESTING; **PTC:** PRODUCTION TEST COUPON



**MANUFACTURER'S NAME & ADDRESS**  
**BHEL: VISAKHAPATNAM**  
**APPROVED VENDOR**

## STANDARD QUALITY PLAN

**ITEM: DISHED ENDS OF COLUMNS & PRESSURE VESSELS**

**BHEL SPECIFICATION: HPVP: DG: ENGG: 031**

**QP NO.: SQP: H: PP:29**  
**REV.NO.01 DATE: 02.04.2026**  
**PAGE: 6 OF 7**

SL. NO.	COMPONENT & OPERATIONS	CHARACTERISTICS	CLASS	TYPE OF CHECK	QUANTUM OF CHECK		REFERENCE DOCUMENT	ACCEPTANCE NORMS	FORMAT OF RECORD		AGENCY			REMARKS
					B	C					M	B	C	
1	2	3	4	5	6	7	8	9	D*	**	10	11		

### APPENDIX SHEET CONTAINING ADDITIONAL REQUIREMENTS APPLCABLE IN CASE OF CLAD MATERIAL:

1.0	Clad Restoration on L-Seam weld & test coupon	Continuity of Clad	MA	-	100%	Approved Procedure	IR	√	P				(if weld is applicable in Clad Plate)
2.0	100% PT on Clad restoration each layer	Detection of flaws	MA	-	100%	Drawing & ASME Sec VIII Div I	IR	√	P				(if the Material of Construction is Clad Plate)
3.0	Copper Sulphate test on L-seam after barrier layer deposition and preparation before start of deposition of subsequent layers	Detection of flaws	MA	-	100%	Approved Procedure	IR	√	P				(if M O C is from clad Plate)
4.0	Ferroxyl Test after L-seam Clad restoration	No iron contamination	MA	-	100%	Approved Procedure	IR		P				As applicable

**LEGEND:** RECORDS, IDENTIFIED WITH "TICK" (√) AGAINST "D" SHALL BE ESSENTIALLY INCLUDED BY SUPPLIER IN FINAL DOCUMENTATION.

\*\* **M:** MANUFACTURER **B:** BHEL QC / BHEL AUTHORISED INSPECTION AGENCY **C:** CUSTOMER **P:** PERFORM. **W:** WITNESS. **V:** VERIFICATION OF DOCUMENTS CLASS : **CR** - CRITICAL; **MA** - MAJOR; **MI** - MINOR; **MTC**- MILL /MANUFACTURER'S TEST CERTIFICATE; **TDC:** TECHNICAL DELIVERY CONDITIONS **IR** - INSPECTION/TEST REPORT; **WPS:** WELDING PROCEDURE SPECIFICATION **PQR:** PROCEDURE QUALIFICATION RECORD **WQR:** WELDER QUALIFICATION RECORD **HT:** HEAT TREATMENT **PFHT:** POST FORMING HEAT TREATMENT; **NDE:** NON DESTRUCTIVE EXAMINATION **LPI:** LIQUID PENETRANT INSPECTION **MPI:** MAGNETIC PARTICLE INSPECTION **RT:** RADIOGRAPHIC TESTING **UT:** ULTRASONIC TESTING; **PTC:** PRODUCTION TEST COUPON



**MANUFACTURER'S NAME & ADDRESS**  
**BHEL: VISAKHAPATNAM**  
**APPROVED VENDOR**

### STANDARD QUALITY PLAN

**ITEM: DISHED ENDS OF COLUMNS & PRESSURE VESSELS**

**BHEL SPECIFICATION: HPVP: DG: ENGG: 031**

**QP NO.: SQP: H: PP:29**  
**REV.NO.01 DATE: 02.04.2026**  
**PAGE: 7 OF 7**

SL. NO.	COMPONENT & OPERATIONS	CHARACTERISTICS	CLASS	TYPE OF CHECK	QUANTUM OF CHECK		REFERENCE DOCUMENT	ACCEPTANCE NORMS	FORMAT OF RECORD		AGENCY			REMARKS
					B	C					M	B	C	
1	2	3	4	5	6	7	8	9	D*	**	10	11		

5.0	Disbondment check (100% UT) for rolled sections of clad and weld overlay	Lack of bonding	MA	-	100%	Drawing & ASME Sec VIII Div I	UT Report	√	R				
6.0	Ferrite Number (2 spots per seam/overlay)	Microstructure % Delta Ferrite	MA	-	100%	ASTM standard	Report	√	P				Using Ferrite Scope
7.0	Chemical Analysis after Clad Restoration and before forming & heat treatment	Chemical properties	MA	-	100%	Approved Procedure	IR	√	P				

**LEGEND:** RECORDS, IDENTIFIED WITH "TICK" (√) AGAINST "D" SHALL BE ESSENTIALLY INCLUDED BY SUPPLIER IN FINAL DOCUMENTATION.  
**\*\* M:** MANUFACTURER **B:** BHEL QC / BHEL AUTHORISED INSPECTION AGENCY **C:** CUSTOMER **P:** PERFORM. **W:** WITNESS. **V:** VERIFICATION OF DOCUMENTS CLASS : **CR** - CRITICAL; **MA** - MAJOR; **MI** - MINOR; **MTC**- MILL /MANUFACTURER'S TEST CERTIFICATE; **TDC:** TECHNICAL DELIVERY CONDITIONS **IR** – INSPECTION/TEST REPORT;  
**WPS:** WELDING PROCEDURE SPECIFICATION **PQR:** PROCEDURE QUALIFICATION RECORD **WQR:** WELDER QUALIFICATION RECORD **HT:** HEAT TREATMENT **PFHT:** POST FORMING HEAT TREATMENT; **NDE:** NON DESTRUCTIVE EXAMINATION **LPI:** LIQUID PENETRANT INSPECTION **MPI:** MAGNETIC PARTICLE INSPECTION **RT:** RADIOGRAPHIC TESTING **UT:** ULTRASONIC TESTING; **PTC:** PRODUCTION TEST COUPON



**BHARAT HEAVY ELECTRICALS LIMITED**  
**HEAVY PLATES & VESSELS PLANT-VISAKHAPATNAM-530012**  
**WELDING TECHNOLOGY**  
**WELDING PROCEDURE SPECIFICATION**

WPS No. : M.1.1.02      Date : 16 / 06 / 2015      Supporting  
 Rev No. : 02      Date : 01 / 07 / 2024      PQR No. 3631

Welding Process : SMAW      Type : Manual  
 (Auto/Semi-Auto/Manual/Machine)

Application : Groove welding of P1 Group 1 or 2 Carbon steel components with P1 Group 1 or 2 Carbon steel components & For all Fillet welds of P1 materials.

**JOINTS (QW-402)**

Joint Design : Groove as per approved fabrication drawing  
 Backing (Yes/No) : SMAW: Yes  
 Backing Material (Type) : SMAW: Metal  
 ( Metal/Non fusing metal/ Non metallic/Others )  
 Root Spacing : As per approved fabrication drawing

**BASE METAL (QW-403)**

P. No. : 1      Group No : 1, 2      TO      P. No. : 1      Group No : 1, 2  
 Spec. Type & Grade : N.A.  
 Chem. Analysis & Mech. Prop : N.A.  
 Thickness Range (T) Groove : 5 to 200.0mm      Fillet : All Thicknesses.  
 Maximum Pass Thickness  $\leq 13$ mm (Yes): Yes (No): \_\_\_\_\_  
 Others : Nil

**FILLER METALS (QW-404)**

	<u>SMAW</u>	Size of filler metal	: Ref. Table
AWS No. (Class)	: E7018	Filler Metal Product Form	: N.A.
Specn. No. (SFA)	: 5.1	Flux trade name	: N.A.
F. No.	: 4	Electrode-flux (Class)	: N.A.
A. No.	: 1	Consumable insert	: N.A.

Deposited weld

metal thickness range (t)  
 Groove : Max.200.0mm (Max.4mm/pass)  
 Fillet : All  
 Others : None

**POSITION (QW-405)**

Position(s) of Groove : All  
 Position(s) of Fillet : All  
 Weld Progression : Uphill  
 Others : Nil

**PREHEAT (QW-406)**

Preheat Temp. (min) : 38°C for T  $\leq$  32 mm  
 95°C for T > 32 mm  
 Interpass Temp. (max) : 150 °C  
 Postheat Maintenance : Not required.  
 Others: : Preheat extend to 75mm on either side of weld





**PWHT (QW-407)**

Temp. Range : 900 ± 10°C (N.R) & 610 ± 10°C (S.R)  
Time Range : As per N.R & S.R cycle  
Others : None

**GAS (QW - 408)**

	<u>Gases</u>	<u>Mix %</u>	<u>Flow Rt.(lpm)</u>
Shielding	N.A	---	---
Trailing	N.A.	----	----
Backing	N.A.	----	----

**ELECTRICAL CHARACTERISTICS (QW – 409)**

Current (AC/DC) : Refer Table      Polarity : Refer Table  
Amps (Range) : Refer Table      Volts : Refer Table  
Tungsten Electrode type and size : N.A.  
Mode of Metal transfer for GMAW : N.A.  
Electrode wire feed speed range : N.A.  
Pulsing current (GTAW) : N.A.  
Heat input (Max.) : N.A.

**TECHNIQUES (QW-410)**

String or Weave Bead : String  
Oscillation / Weaving : N.A.  
Initial and Interpass Cleaning : Chipping, Wire brushing & Grinding  
Method of Back Gouging : Grinding or Air arc gouging.  
Orifice or Gas cup size : N.A  
Contact tube to work distance : N.A  
Multiple or single pass (per side) : Multiple  
Multiple or single Electrode : Single  
Electrode spacing : N.A  
Travel Speed Range : N.A.  
Peening : None  
Use of thermal processes : None  
Others : Nil

Weld Layer(s)	Process	Filler Metal		Current		Volt Range V	ROL/ Travel speed Range	Others
		Class	Dia.(mm)	Type	Amps.			
Root (L1)	SMAW	E9018G	3.15	DCEP	80-110	24-28	140mm minimum/electrode	Nil
L2	SMAW	E9018G	4.0	DCEP	140-165	24-28	200mm minimum/electrode	Nil
L3	SMAW	E9018G	5.0	DCEP	180-220	24-28	250mm minimum/electrode	Nil
Subsequent	SMAW	E9018G	5.0	DCEP	180-220	24-28	250mm minimum/electrode	Nil

Prepared by:

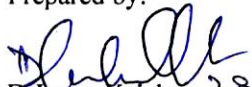
  
D Leva Krishna 29/08/2024  
Engineer / WT

Approved by:

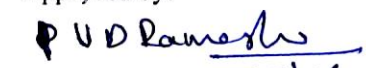
  
P V D Ramesh 29/8/24  
Sr. Manager / WT