

Bharat Heavy Electricals Limited
Heavy Plates & Vessels Plant
Visakhapatnam – 530 012
Andhra Pradesh, INDIA



Tel. +91 - 891 668 1332 / 1359

E-mail : yvrrao@bhel.in
dnmurthy@bhel.in

INVITATION TO TENDER

Ref.: OS/24-25/8013/IBR DE/03/003

Date: 21.05.2024

Sub: Cold Forming of CS Dished Ends (IBR) against S.O. No. 8013 with free issue materials at vendor's works

Dear Sir,

Sealed tenders are invited for the subject work in **two part bid** system from **IBR approved Vendors only** subject to the following **eligibility criteria**:

- (1) Bidders must have an experience in execution of similar jobs in the past 7 Years as on 30.04.2024. Bidders shall enclose Work Orders, Work Completion Certificates and all other relevant documents in support of their experience in execution of similar job for at least one project.
- (2) Bidders shall have to enclose the documents of **valid IBR Registration**, Registration of Firm/ Factory License/ Certificate of Incorporation, PAN, GSTIN, Udyam Registration Certificate (if registered with MSME) etc.
- (3) The works executed in own name of the individual / firm of the tenderer will only be considered for eligibility criteria.

1. VENDOR'S SCOPE OF WORK:

- a) Cold Forming of Carbon Steel Dished Ends (2:1 Ellipsoidal & Spherical Dishes) – **22 nos.** as detailed in Annexure– II with free issue Cut to size blanks as per applicable Drawings, QAP, Specifications, Procedures etc. Wherever blanks are made from segments, Cut-to-Size blanks will be issued by BHEL-HPVP after joint welding with radiography clearance.
- b) Collection of Cut to Size blanks from Production Shops at HPVP-Visakhapatnam, Transportation of (i) Blanks from BHEL-HPVP, Visakhapatnam to Vendor works and (ii) Formed Dished Ends back to BHEL-HPVP, Visakhapatnam including transit insurance and delivery at BHEL-HPVP Production shops.
- c) Profile of Spherical Dished Ends shall match with the outer diameter of Dished End as per drawings and the same are to be delivered in tack welded condition with respective Dished Ends as per the drawings.
- d) Free issue items i.e. Cut to Size Blanks cleared by QC (Shop) are to be collected within 5 days from the date of intimation by HPVP Outsourcing dept. without any failure. Any delay beyond 5 days shall be considered for levy of LD.
- e) Dished End supplier shall verify & confirm the blank diameter required to meet overall dimensions and minimum thickness.
- f) Dimensions, ID & Thickness of formed dished ends shall be strictly within the tolerances given in the drawings, QAP / ITP.
- g) Material identification no. is to be maintained by Dish End manufacturer before, during & after forming operation.
- h) Obtaining approval of drawings from concerned Director of Boilers as per requirement and Co-ordination with IBR authorities and BHEL authorized inspection agency for Stage wise and Final Inspection and obtaining inspection clearance.
- i) Normalizing shall be carried out as per respective drawings & QAP. HT Charts shall be submitted to BHEL/TPIA & IBR along with the inspection reports for clearance for further operations.
- j) IBR Fees / Charges shall be in Bidder's scope.
- k) All NDT requirements shall be carried out as per applicable drawings, approved QAP, Standards & procedures.
- l) PT shall be carried out on both sides of Knuckle area and weld seams as per approved QAP & drawings.

Contd...2

- m) UT shall be carried out on finished Dished ends after forming as per approved QAP & drawings.
- n) Preparation of necessary documentation as per IBR regulations and obtaining **IBR certification** for finished dished ends & Spherical dishes.
- o) Ovality at any cross section shall not exceed 0.5% of the nominal diameter and actual ovality readings at the SF end are to be mention in the dimension report.
- p) Template used for checking the profile to be sent along with dished end by the vendor.
- q) The Straightness of SF is to be ensured and the same is to be reported in the dimensional report.
- r) The ID Dimension to be measured at SF and the same is to be reported in the dimensional report.
- s) Though not mentioned specifically, any activity which is required for completion of the work is deemed to be included in the scope of bidders without any price implication.

2. LOCATION OF WORK SPOT:

Cold Forming of Dished ends shall be carried out at **Vendor's Works**.

3. BHEL SCOPE:

- a) Issue of Drawings, Approved QAP etc.
- b) Issue of Cut-to-Size Blanks. Wherever blanks are made from segments, Cut-to-Size blanks will be issued after joint welding with radiography clearance.
- c) Loading of Blanks and unloading of finished Dished Ends at BHEL – HPVP, Visakhapatnam
- d) Height & TL Marking, Cutting of extra height and Edge Preparation as per drawings

4. INSPECTION:

- a) Inspection shall be carried out at Vendor's works by M/s. BHEL / BHEL Authorized Inspection Agency and D.O.B. (Concerned Region) / IBR authority as per approved QAP.
- b) Approved QAP & drawings issued to the vendor after ordering shall only be followed for execution and inspection of the job.
- c) Dished End supplier shall furnish Inspection Reports for a) Method of Forming, b) Intermediate Heat Treatment, if any carried out, c) Dimensional Report including minimum thickness, ovality readings at the SF end, Straightness of SF, ID Dimension at SF etc., d) NDE Reports, e) Results of Template check etc., to BHEL as per approved QAP.
- d) All the documentation related to inspection clearance of BHEL / TPI / IBR / Customer, Generation of Inspection Reports, Preparation of Final Documents etc., as per BHEL standard formats is included in the scope of vendor and submission of soft copy as well as hard copy of the same to BHEL-QA.

5. DELIVERY:

- a) Finished Dished ends along with all the relevant inspection documents as per approved QAP and all other certificates are to be delivered to HPVP, Visakhapatnam **within 8 weeks from the date of issue of blanks** at HPVP shops.
- b) The delivery period will be calculated from the date of issue of blanks at HPVP, Visakhapatnam to the date of delivery of finished Dished Ends at HPVP, Visakhapatnam.
- c) In case the delivery period offered by the vendor is more than the tender delivery, Loading for additional delivery period shall be @ 1/2 % per week or part thereof on the price quoted by the vendor for the purpose of evaluation of L1 status.

6. PRICE:

- a) L1 status shall be evaluated based on the total quoted value.
- b) Bidder has to quote for all the items. Part quotation is not acceptable.

- c) The price shall be quoted in the **Price Bid** as per the Schedule of Quantities & Rates for the detailed scope of work and the quoted price shall be inclusive of all applicable taxes & duties except GST.
- d) The prices shall be fixed & firm without any escalation during the entire period of contract and till completion of the work.
- e) Income tax shall be deducted at applicable rates from the vendor's bills. GST shall be reimbursable to the vendor as per applicable guidelines.

7. VALIDITY OF OFFER:

The offer shall be valid for a period of **3 months** from the date of Reverse Auction.

8. GOODS & SERVICES TAX (GST):

Bidders shall make a note of the following points of GST before submission of their offer: -

- a) Vendors shall have to mention their GSTIN no. (15 Digits) in their Technical Bid. If any specific exemption is available, a declaration with due supporting documents need to be furnished for considering their offer.
- b) Semi-finished goods are to be delivered by the Vendors in BHEL, HPVP premises within a maximum period of one year from the date of issue of the material, failing which the whole transaction will be considered as Supply and Sale and GST is required to be paid along with interest (calculated @ SBI Base Rate + 6%) along with penalty, if any, from the date of Challan on the whole value of materials. Hence vendors shall have to ensure that materials issued to them are returned within 365 days.
- c) After fabrication, the vendors shall have to deliver the Semi-Finished Goods by fulfilling the following formalities: -
 - i) GST invoice should be raised by the vendors by paying GST on job work charges at applicable rates and by incorporating the HPVP GSTIN no. in the invoice for availing the reimbursement of GST from HPVP.
 - ii) The vendor shall also have to enter in their GST Return -1 (GSTR-1) the details of invoice raised for payment of GST so as to enable HPVP to avail input credit.

9. REVERSE AUCTION:

- a) BHEL shall be resorting to Reverse Auction (RA) for this tender. RA shall be conducted among the techno-commercially qualified bidders. Business Rules for Reverse Auction are given at Annexure – V and Guidelines for Reverse Auction are available on our website, www.bhel.com → supplier registration → Guidelines for Reverse Auction, before submission of their offer.
- b) Sealed envelope / Electronic Price bids of all the techno-commercially qualified bidders shall be opened and the same shall be considered as initial bids of the bidders in RA. In case any bidder(s) do(es) not participate in online Reverse Auction, their sealed envelope / Electronic price bid along with applicable loading, if any, shall be considered for ranking.
- c) BHEL will inform bidders the details of service provider who will provide business rules, all necessary training and assistance before commencement of online bidding. The bidders participating in the Reverse Auction shall have to necessarily submit '**Process Compliance Form**' (PCF) to the designated Service Provider.
- d) Bidders are advised to read the 'Business Rules' (Annexure – V) indicating details of RA event carefully, before reverse auction event.

10. RISK PURCHASE:

In case the contractor fails to execute the work within the scheduled time or due to any other reasons, BHEL – HPVP reserves the right to get the same completed through some other party at the risk & cost of the contractor and any additional expenditure incurred due to the same shall be charged to the contractor. Non-performance of contractor attracts penal provisions in line with BHEL Guidelines for Suspension of Business Dealings.

11. GENERAL:

- a) The bidders shall study the Tender documents, Drawings, Quality Documents and all other relevant documents in detail for understanding the scope of work and the processes involved before submission of offer. Bidders shall get clarifications, if any, from concerned officials on the scope of work or any other details of the tender document, over phone between 09:00 AM and 04:00 PM on any working day (or) through e-mail.
- b) **Conditional / Partial Price Bids** and any other deviations to the tender terms & conditions are not acceptable and BHEL reserves the right to reject such offers without further correspondence. Bidders shall confirm their acceptance to all the terms & conditions of the tender enquiry in the Techno-commercial Bid.
- c) BHEL reserves the right to modify or cancel the tender enquiry at any stage without assigning any reasons thereof.
- d) The General Terms & Conditions, if any, contradicting with the specific terms & conditions given in the tender, then specific terms & conditions shall only be considered.

12. Other Terms & Conditions, whichever are applicable, shall be as per Annexure – III enclosed.

13. The following documents shall form part of the tender enquiry including this Notice Inviting Tender:

PART - 1: TECHNO COMMERCIAL BID

- | | |
|---|------------------|
| i) Schedule of Quantities | : Annexure – I |
| ii) Details of Dished Ends to be formed | : Annexure – II |
| iii) General Terms & Conditions | : Annexure – III |
| iv) Acceptance to tender terms & conditions | : Annexure – IV |
| v) Business Rules for Reverse Auction | : Annexure – V |
| vi) GST Compliance for Indigenous Suppliers | : Annexure – GST |
| vii) Applicable Drawings & QAP | |

PART - 2: PRICE BID

- viii) Price Bid (Schedule of Quantities & Rates)

14. TENDER SUBMISSION (Through e-Procurement system):

- a) The tender completed in all respects shall be submitted in **Two parts** (Techno-commercial bid and Price Bid) through online e-procurement portal (<https://eprocurebhel.co.in>) latest by **13:00 Hrs. on 31.05.2024**.

Note: Techno-commercial bid along with all the tender documents shall be duly signed & stamped by the bidder on all pages.

- b) Submission of offer by the bidder implies that all the tender documents were read by the bidder and the bidder is aware of the scope and specifications of the job.
- c) **OFFERS SENT IN ANY OTHER FORM WILL BE TREATED AS INVALID AND WILL BE SUMMARILY REJECTED.**

15. TENDER OPENING:

- a) Techno-commercial Bids will be opened on **31.05.2024 at 15:00 Hrs.** in online e-procurement portal.
- b) After evaluation of the Techno-commercial Bids, intimation regarding date & procedure of conducting reverse auction shall be given by the service provider to all eligible techno-commercially qualified bidders through an e-mail in advance at an appropriate time.

For Bharat Heavy Electricals Limited,

D. N. Murthy
21/05/2024
D. N. MURTHY
Dy. Manager (OS)

Bharat Heavy Electricals Ltd
HPVP, Visakhapatnam-530 012

Sub: Cold Forming of CS Dished Ends (IBR) against S.O. No. 8013 with Free Issue materials at vendor's works

SCHEDULE OF QUANTITIES

Sl. No.	S.O. No.	Description of Item	Unit	Qty.
		Cold Forming of CS Dished ends (IBR) as per applicable Drawings, QAP, Specifications, Procedures etc., including collection & transportation of Blanks, Co-ordination with IBR / D.O.B. and BHEL authorised inspection agency for Stagewise & Final inspection and obtaining necessary inspection clearance along with relevant documentation and delivery of finished dished ends at BHEL-HPVP, Visakhapatnam as per the detailed scope of work mentioned in the tender.		
1		2:1 Ellipsoidal Dished ends (IBR)		
1.1	8013	ID 4000 mm x 25 mm (Min) Thk. from a blank of OD 5000 mm x 32 mm thk. - Wt. 4932.9 Kgs. each	Nos.	4
1.2	8013	ID 3000 mm x 25 mm (Min) Thk. from a blank of OD 3750 mm x 32 mm thk. - Wt. 2849.27 Kgs. each	Nos.	4
2		Spherical Dishes (IBR)		
2.1	8013	OD 950 x 25 THK (Min.) from a blank of OD 1250 x 32 mm THK. - Wt. 308.31 Kgs. each	Nos.	4
2.2	8013	OD 700 x 25 THK (Min.) from a blank of OD 900 x 32 mm THK. - Wt. 178.08 Kgs. each	Nos.	2
2.3	8013	OD 1700 x 25 THK (Min.) from a blank of OD 2200 x 32 mm THK. - Wt. 955.02 Kgs. each	Nos.	2
2.4	8013	OD 950 x 25 THK (Min.) from a blank of OD 1200 x 32 mm THK. - Wt. 284.14 Kgs. each	Nos.	2
2.5	8013	OD 450 x 25 THK (Min.) from a blank of OD 650 x 32 mm THK. - Wt. 83.37 Kgs. each	Nos.	4
		Total		22

Notes :

- 1) a) **L1 status will be evaluated based on total quoted price.**
b) Bidder has to quote for all the items. Part quotation is not acceptable.
- 2) The quantity indicated above is tentative and may vary subject to the requirement at the time of ordering / execution. However, payment shall be made for the actual quantity only.
- 3) The prices shall be fixed & firm without any escalation during the entire period of contract and till completion of work.
- 4) The quoted price shall be inclusive of all applicable taxes & duties except GST. However, GST shall be reimbursed by BHEL on submission of proof of GST payment.
- 5) The bidders are advised to go through all the drawings & documents before quoting the tender.

Signature of the Bidder with Stamp

Details of Dished Ends to be formed

Ref : OS/24-25/8013/IBR DE/03/003

Date: 21.05.2024

Sub: Cold Forming of CS Dished Ends (IBR) against S.O. No. 8013 with Free Issue materials at vendor's works

SL No.	S.O. No.	PGMA	DRAWING No.	REV. No.	DESCRIPTION	SPEC	Dished End Size (mm)	Blank Size (mm)	QTY (Nos.)	Blank Weight (Kg)	Total Weight (Kg)
1	2:1 Ellipsoidal Dished Ends (IBR)										
1.1	8013	01-000	4-163-10-00743	0	2:1 Ellipsoidal Dished End	SA 516 GR.70	ID 4000 x 25 (Min) THK	OD 5000 x 32 THK	4	4932.9	19731.6
1.2	8013	02-000	4-163-10-00745	0	2:1 Ellipsoidal Dished End	SA 516 GR.70	ID 3000 x 25 (Min) THK	OD 3750 x 32 THK	4	2849.27	11397.08
2	Spherical Dishes (IBR)										
2.1	8013	01-000	4-163-10-00743	0	Spherical dishes-01	SA 516 GR.70	OD 950 x 25 (Min) THK	OD 1250 x 32 THK	4	308.31	1233.24
2.2	8013	01-000	4-163-10-00743	0	Spherical dishes-02	SA 516 GR.70	OD 700 x 25 (Min) THK	OD 900 x 32 THK	2	178.08	356.16
2.3	8013	02-000	4-163-10-00745	0	Spherical dishes-01	SA 516 GR.70	OD 1700 x 25 (Min) THK	OD 2200 x 32 THK	2	955.02	1910.04
2.4	8013	02-000	4-163-10-00745	0	Spherical dishes-02	SA 516 GR.70	OD 950 x 25 (Min) THK	OD 1200 x 32 THK	2	284.14	568.28
2.5	8013	02-000	4-163-10-00745	0	Spherical dishes-03	SA 516 GR.70	OD 450 x 25 (Min) THK	OD 650 x 32 THK	4	83.37	333.48
								TOTAL	22		35529.88

GENERAL TERMS & CONDITIONS**1. TECHNICAL DELIVERY CONDITIONS:**

The work should conform to the technical data given in our drawings, GMS, Shipping List Specifications, QAP, WPS etc.

2. PARTY'S SCOPE:

The scope of the party shall be as follows: -

- a) All welding equipments, baking oven, tools, jigs and fixtures, measuring instruments duly calibrated, handling facilities, testing facilities etc.
- b) All materials other than those mentioned under "Free Issue Materials", which are required for completion of the work.
- c) All consumables such as electrodes, gases, grinding wheels etc.

Note: Electrodes of specification mentioned in the drawings / WPS and of BHEL approved brands only shall be used and MTCs of the same shall be submitted to BHEL for verification before use.

3. REVISION OF DRAWINGS:

There may be minor changes in the drawings during execution. In such a case, party should accommodate the same without any extra claim.

4. WELDING QUALIFICATION: Qualification of required number of Welders is party's responsibility at their cost.**5. X-RAY:**

All welding shall be of X-ray quality where specified on drawings. Inspection would specify the quantum of X-ray based on drawings / code requirement. Party should strictly follow the WPS and QAP issued by BHEL during welding. Getting the welds radiographed and getting them cleared by inspection is the responsibility of the party.

6. RECTIFICATIONS / REJECTIONS:

Any rectification due to defective work, if required, shall be done by the party free of charge with a suitable technology approved before hand by BHEL in writing. The cost of material, if any used for rectification work / rejection work, will be estimated by BHEL and the same shall be debited to party's account. In case any rectification / rework is to be carried out due to defective material supplied by BHEL, the replacement material and consumables will be supplied by BHEL free of Cost.

7. SECURITY DEPOSIT:

- a) Vendors shall have to submit a Bank Guarantee for **10%** of the order value in case of **HPVP ADM / Lovagarden site** (or) **25%** of the material cost in case of Vendor works towards Security Deposit and safe custody of free issue materials within 15 days from the date of intimation by Outsourcing dept. The BG shall be valid for the contract period with a claim period of 12 months. This Bank Guarantee shall be released to the contractor after completion of work and on acceptance of the same by BHEL / Owner.

Bidder agrees to submit performance security required for execution of the contract within the time period mentioned above. In case of delay in submission of performance security, enhanced performance security which would include interest (SBI rate + 6%) for the delayed period, shall be submitted by the bidder. Further, if performance security is not submitted till such time the first bill becomes due, the amount of performance security due shall be recovered as per terms defined in NIT/contract, from the bills along with due interest.

- b) **MODE OF DEPOSIT:** Security Deposit may be furnished in the following forms:

- i) Local cheques of Scheduled Banks (subject to realization)/ Pay Order/ Demand Draft/ Electronic Fund Transfer in favour of BHEL.
- ii) Bank Guarantee from Scheduled Banks / Public Financial Institutions as defined in the Companies Act. The Bank Guarantee format should have the approval of BHEL.
- iii) Fixed Deposit Receipt issued by Scheduled Banks / Public Financial Institutions as defined in the Companies Act (FDR should be in the name of the Contractor, a/c BHEL).
- iv) Securities available from Indian Post offices such as National Savings Certificates, Kisan Vikas Patras etc. (held in the name of Contractor furnishing the security and duly endorsed/ hypothecated/ pledged, as applicable, in favour of BHEL).
- v) Insurance Surety Bond.

(Note: BHEL will not be liable or responsible in any manner for the collection of interest or renewal of the documents or in any other matter connected therewith).

8. PERFORMANCE BANK GUARANTEE:

Vendors shall have to submit Performance Bank Guarantee (claim period of 12 months) for 10% of the order value covering for the defects liability period. If PBG is not submitted, 10% of the order value shall be deducted towards PBG from the final bill and shall be refundable after performance guarantee period, if no defects are found during this period.

9. RAW MATERIALS ISSUE:

Raw materials shall be issued with appropriate processing allowance and invisible wastage over the theoretical requirement of raw materials (**Plates, Sheets, Sections and Pipes**).

10. TRANSFER / RETURN OF LEFT OVER MATERIALS:

Party should maintain proper records for receipt & use of all free issue materials. The left over materials & scrap as per the material accounting statement shall be returned to HPVP stores along with finished job. Material Transfer Vouchers (MTV) from one order to another or from one vendor to another and Material Return Vouchers should be submitted immediately after transfer / return. The material reconciliation statement shall be submitted by the contractor after verification and certification by BHEL along with the final bill **within 30 days from the date of completion of work**. Otherwise, recovery for the balance materials shall be made from any of their pending bills without further intimation.

11. MATERIAL RECONCILIATION:

Orders issued to the vendors have to be completed in all respects including Material Accounting within a maximum of **180 days** from the **date of issue of material** from BHEL - HPVP stores.

Maximum of 0.5 % on the requirement of materials (**Plates, Sections and Pipes**) is admitted towards **process allowance and invisible wastage**.

Scrap quantity is permissible up to a **maximum of 1% on Structural (Beams, Channels, Angles, Rods, Pipes etc.)**, **2% on Sheets**, **3% for Plates** on the theoretical requirement of materials.

If wastage and scrap is beyond the above limits, it should be fully justified with cutting diagrams etc. which are to be approved in advance by BHEL. **Otherwise, the cost of raw materials beyond approved limits will be recovered from the contractor as per BHEL recovery rates including applicable taxes & duties.**

Material reconciliation including return of balance materials, off-cuts is to be completed within 20 days from the date of completion of the order. The material reconciliation statement shall be submitted by the contractor after verification and certification by BHEL-HPVP along with the final bill **within 30 days from the date of completion of work**. Otherwise, recovery for the balance materials shall be made from any of their pending bills without further intimation,

Repeated occurrence of inordinate delays in returning and settling the material accounting will entail BHEL the right to terminate the contract forthwith or impose a temporary suspension on further loading at the discretion of BHEL.

12. SCRAP & OFF-CUT NORMS:

Sl. No.	Description	Scrap Size (in mm)	Off-Cut (in MM)
1.	CS/AS Sheets & Plates	Below 500 × 250	500 × 250 & above
2.	Rolled sections Rod, angles etc. (other than -tubes, pipes)	Below 1000	1000 & above
3.	Tubes & Pipes	Below 500	500 & above
4.	Universal column	Below 1000	1000 & Above
5.	SS Sheets & Plates	Below 500 × 250	500 × 250 & above
6.	SS Structural, Rods, Tubes, Pipes	Below 250	250 & above
7.	Non – ferrous: sheets & plates, rods & tubes	Below 500 × 250 (S & PL), Below 250 (Rods & Tubes)	500 × 250 & above, 250 & above
8.	Big size Scrap	(2500 & above) × (150 to 249)	-

13. INSPECTION:

Party shall contact our Quality Control Dept. for stages of inspection before commencement of job and should strictly follow the stages of inspection as per QAP.

14. WORKMANSHIP GUARANTEE:

The vendors should give workmanship guarantee for fabricated items for a period of 18 months from the date of last delivery of the order. Any defects due to incomplete work, faulty workmanship found in the fabricated items after delivery during the defects liability period shall be rectified / replaced by the vendor free of cost. Otherwise, the expenditure incurred towards the same will be recovered from the pending bills of vendors.

15. WORK PROGRESS:

The fabricator shall furnish a weekly report on the progress of work along with the status of availability of free issue materials and requirement of further materials, if any.

Outsourcing dept. personnel will visit vendor's works from time to time to assess and review the work progress. Free access shall be provided to BHEL or its inspection agency at all reasonable times of the day / night.

In case the progress is not satisfactory or supplies are delayed abnormally beyond the contractual delivery date, BHEL-HPVP, Visakhapatnam reserves the right to cancel the order in part or full or get the balance job in as is where is condition completed elsewhere by another agency at the risk and cost of Fabricator. The value of the work carried out by the party will be assessed by BHEL and the same shall be final. No compensation will be given to the fabricator in case of cancellation of order or diversion of balance job even if the jobs have been processed partly.

16. DELIVERY:

Finished items should be handed over to BHEL-HPVP on party's delivery challans along with Job completion certificate / Final Inspection Report from inspection agency / HPVP-QC department.

17. PENALTY:

Penalty calculations will be done on DU wise (Dispatchable Unit) delivery. If delivery exceeds the stipulated delivery schedule, penalty @ 1/2 % of the value of each DU per week (or) part thereof subject to a maximum of 10% of the value of each DU will be levied. However, time taken for the following will not be considered as delay on the part of the Sub-Contractor.

- 1) Intermediate operations, if any, carried out by BHEL.
- 2) Waiting time for BHEL / Third party Inspection beyond a normal time of 3 days.

18. PAYMENT TERMS:

Payment shall be made against RA Bills within 45 days for MSE (Micro & Small Enterprise), 60 days for Medium Enterprise and 90 days for non-MSEs from the date of submission of Bill.

90% payment will be made after handing over of the finished equipments along with all inspection documents to HPVP shops / Logistics dept. / ADM site / Lova Garden site, duly inspected & cleared by Inspection authority. Balance 10% payment shall be made along with the Final Bill against completion of total order in all respects including documentation.

Vendors shall have to submit the bills in the formats specified by HPVP-Outsourcing and the bills submitted in the specified format along with necessary supporting documents are only admitted for processing. The following documents shall be submitted along with the Final Bill: -

1. No Claim Certificate from the contractor
2. No Dues Certificate from BHEL
3. Work Completion Certificate from BHEL
4. Material Reconciliation Statement submitted by the Contractor and certified by concerned authority of BHEL (if applicable)
5. Workmanship Guarantee certificate from the contractor

19. SECRECY:

All the documents of BHEL inclusive of Drawings, GMS and Standards made available to the fabricator should be kept in strict confidence and under no circumstance be made available to others or allow others to make use of them. Such documents shall be returned to BHEL on demand after completion of the job. This secrecy clause is binding on the employees of the fabricators also. Violation of the same may lead to suspension of business with the vendor and necessary legal action.

20. SUB-LETTING:

In general, sub-letting of jobs will not be permitted. But in special circumstances, this may be allowed. In such case, the party should obtain written approval from BHEL-HPVP, Visakhapatnam before sub-letting.

21. FACTORY RULES AND REGULATIONS:

Party shall abide by all the rules and statutory regulations in force from time to time as per factories act. It shall be party's responsibility to ensure the safety of their workmen and fulfilling the ESI, PF and other relevant statutory regulations.

22. SAFETY:

- a) Contractor shall adhere to safe construction practices, guard against hazardous & unsafe working conditions and shall comply with the safety rules of BHEL and local authorities. He shall maintain First Aid facilities for all his employees and labour. Contractor's responsibility includes supply of welder kit, all safety items such as safety belts, white and colour glasses, goggles, safety helmets, safety shoes etc.
- b) Contractor and his employees shall follow all fire & safety, security regulations of BHEL.

23. HOUSE KEEPING:

During execution of work, the contractor at all times keep the working place and storage area clean and free from accumulation of waste materials, rubbish etc.,

24. ACCIDENT / DAMAGE / CONDUCT ETC.:

Contractor will be held responsible for any disorderly conduct / misconduct, indiscipline, theft, smoking etc., on the part of his men. He will ensure summarily eviction of such men from his premises failing which BHEL would remove them from the factory on his responsibility. Any damage to and or loss of equipment, machinery, building etc., to BHEL or BHEL employees, visitors or other contractors resulting from his own or any of his men's negligence shall be liable to be made good by him. Contractor shall be solely responsible for any accident in which you or your men or your equipment may be involved during the execution of contract on account of any reason what so ever.

25. TERMINATION OF CONTRACT:

In the event of any failure on the part of the contractor, BHEL reserves the right to terminate the contract by giving a notice of 2 weeks for any of the following lapses and contractual violations: -

- a) Failure to make labour payments in time as per the rules
- b) Failure to progress the job according to the agreed schedule
- c) Failure to mobilize adequate man power, tools & tackles and consumables in time
- d) Failure to adhere to Quality Standards of BHEL
- e) Refused to co-operate with other agencies working in the same area
- f) Failure to resolve labour disputes like strikes etc., within 7 days of occurrence
- g) Failure to comply with statutory regulations applicable at BHEL

BHEL shall also be free to intervene and take necessary remedial measures. All costs incurred with interest and overheads shall be recovered from contractor by such foreclosing or off-loading any part of the contract work.

26. CONFLICT OF INTEREST AMONG BIDDERS / AGENTS:

A bidder shall not have conflict of interest with other bidders. Such conflict of interest can lead to anti-competitive practices to the detriment of Procuring Entity's interests. ***The bidder found to have a conflict of interest shall be disqualified.*** A bidder may be considered to have a conflict of interest with one or more parties in this bidding process, if:

- a) they have controlling partner (s) in common; **or**
- b) they receive or have received any direct or indirect subsidy / financial stake from any of them; **or**
- c) they have the same legal representative / agent for purposes of this bid; **or**
- d) they have relationship with each other, directly or through common third parties, that puts them in a position to have access to information about or influence on the bid of another Bidder; or
- e) Bidder participates in more than one bid in this bidding process. Participation by a Bidder in more than one Bid will result in the disqualification of all bids in which the parties are involved. However, this does not limit the inclusion of the components/ sub-assembly/ Assemblies from one bidding manufacturer in more than one bid; or
- f) In cases of agents quoting in offshore procurements, on behalf of their principal manufacturers, one agent cannot represent two manufacturers or quote on their behalf in a particular tender enquiry. One manufacturer can also authorise only one agent / dealer. There can be only one bid from the following:
 - 1. The principal manufacturer directly or through one Indian agent on his behalf, and
 - 2. Indian/foreign agent on behalf of only one principal,
- g) A Bidder or any of its affiliates participated as a consultant in the preparation of the design or technical specifications of the contract that is the subject of the Bid, **or**
- h) In case of a holding company having more than one independently manufacturing units, or more than one unit having common business ownership/management, only one unit should quote. Similar restrictions would apply to closely related sister companies. Bidders must proactively declare such sisters' common business/ management units in same/ similar line of business"

27. OVER RUN COMPENSATION (ORC) / IDLE CHARGES:

The contractor shall not be entitled to claim and the company shall not be liable to pay any amount on account of overrun compensation and idle charges, the overrun/ idling may be for whatsoever reasons.

28. DISPUTES:

Head of BHEL- HPVP Unit will be the final authority for any disputes arising out of this contract. The disputes / arbitration / settlement of contractual or legal issues shall be under the Jurisdiction of Visakhapatnam Court.

- 29.** For this procurement, Public Procurement (Preference to Make in India), Order 2017 dated 15.06.2017 & 28.05.2018 and subsequent Orders issued by the respective Nodal Ministry shall be applicable even if issued after issue of this NIT but before finalization of Contract / PO / WO against this NIT.

In the event of any Nodal Ministry prescribing higher or lower percentage of purchase preference and / or local content in respect of this procurement, same shall be applicable.

- 30.** The Bidder declares that they will not enter into any illegal or undisclosed agreement or understanding, whether formal or informal with other Bidder(s). This applies in particular to prices, specifications, certifications, subsidiary contracts, submission or non-submission of bids or any other actions to restrict competitiveness or to introduce cartelization in the bidding process.

In case, the Bidder is found having indulged in above activities, suitable action shall be taken by BHEL as per extant policies/ guidelines.

31. Order Acceptance:

If the order acceptance is not received within 03 days from the date of release of Sub-contract order, it shall be assumed that the same has been accepted by you thereof.

Signature of the bidder with Stamp

Acceptance to Tender Terms & Conditions

I / We hereby confirm that the Tender documents, Drawings, Quality documents etc. have been studied in detail and we have fully understood the scope of work.

I / We accept to all the Terms and Conditions of the Tender Enquiry and the prices quoted are in accordance with the same.

I / We give our acceptance to participate in reverse auction for this tender.

Tender documents duly signed on all the pages by the Owner / authorized representative of the bidder are attached herewith.

Signature of the bidder with Stamp

BUSINESS RULES FOR REVERSE AUCTION (RA)

This has reference to tender no. **OS/24-25/8013/IBR DE/03/003, dated 21.05.2024**. BHEL shall finalise the Rates for **Cold Forming of CS Dished Ends (IBR) against S.O. No. 8013 with free issue materials at vendor's works** through Reverse Auction mode. BHEL has made arrangement with an authorized Service provider (details will be shared before reverse auction) for conducting RA. Bidders should go through the instructions given below and submit acceptance of the same.

The technical & commercial terms are as per (a) BHEL Tender Enquiry No. **OS/24-25/8013/IBR DE/03/003, dated 21.05.2024**, (b) Bidders' technical & commercial bid (in case of two-part bid) and (c) subsequent correspondences between BHEL and the bidders, if any.

1. Procedure of Reverse Auctioning:

- i) Price bids of all techno-commercially qualified bidders shall be opened.
- ii) **Reverse Auction:** The 'bid decrement' will be decided by BHEL.
- iii) The lowest bidder in sealed envelope price bid shall be shown as current L1 automatically by the system and no acceptance of that price is required. System shall have the provision to indicate this bid as current L1.
- iv) Bidders by offering a minimum bid decrement or the multiples thereof can displace a standing lowest bid and become "L1" and this continues as an iterative process. However, no bidder shall be allowed to lower its bid below the current L1 by more than 5 decrements at one go.
- v) After the completion of the reverse auction, the Closing Price shall be available for further processing.
- vi) Wherever the evaluation is done on total cost basis, after Reverse Auction, prices of individual line items shall be reduced on pro-rata basis.

2. Schedule for reverse auction: The Reverse Auction schedule will be intimated to the techno-commercially qualified bidders at a later stage.**3. Auction extension time:** If a bidder places a bid in the last {...} minutes of closing of the Reverse Auction and if that bid gets accepted, then the auction's duration shall get extended automatically for another {...} minutes, for the entire auction (i.e. for all the items in the auction), from the time that bid comes in. Please note that the auto-extension will take place only if a bid comes in those last {...} minutes and if that bid gets accepted as the lowest bid. If the bid does not get accepted as the lowest bid, the auto-extension will not take place even if that bid might have come in the last {...} minutes. In case, there is no bid in the last {...} minutes of closing of Reverse Auction, the auction shall get closed automatically without any extension. However, bidders are advised not to wait till the last minute or last few seconds to enter their bid during the auto-extension period to avoid complications related with internet connectivity, network problems, system crash down, power failure, etc. The above process will continue till completion of Reverse Auction.

Complaints/ Grievances, if any, regarding denial of service or any related issue should be given in writing thru e-mail/ fax to M/s. {Service provider} with a copy to BHEL within 15 minutes prior to initial closing time of Reverse Auction.

4. Bid price: The Bidder has to quote the {...} Price inclusive of Packing & Forwarding charges, all the routine & type tests as per tender scope, taxes, duties, freight and insurance as specified in tender document including loading (if indicated by BHEL due to deviations in technical/ commercial terms) for the Items specified. Details are as shown in Excel Sheet for calculation of total cost to BHEL (To be specified by Unit as per NIT conditions).**5. Bidding currency and unit of measurement:** Bidding will be conducted in *Indian Rupees per Unit* of the material as per the specifications mentioned in the tender.

In case of foreign currency bids, exchange rate (TT selling rate of State Bank of India) as on scheduled date of tender opening (Part-I bid) shall be considered for conversion in Indian Rupees. If the relevant day happens to be a Bank holiday, then the forex rate as on the previous bank (SBI) working day shall be taken.

6. **Validity of bids:** Price shall be valid for 90 days from the date of reverse auction. These shall not be subjected to any change whatsoever.
7. **Lowest bid of a bidder:** In case the bidder submits more than one bid, the lowest bid at the end of Reverse Auction will be considered as the bidder's final offer to execute the work.
8. Unique user IDs shall be used by bidders during bidding process. All bids made from the Login ID given to the bidders will be deemed to have been made by the bidders/ bidders' company.
9. **Post auction procedure:** BHEL will proceed with the Lowest Bid in the Reverse Auction for further processing.
10. Any commercial/ technical loading shall be separately intimated to respective bidders prior to RA. The excel sheet provided in this regard shall cover all these aspects. Commercial/ technical loading if any, shall be added by the respective bidder in its price during Reverse Auction. Modalities of loading & de-loading shall be separately intimated to the bidders. The responsibility for correctness of total cost to BHEL shall lie with the bidders.
11. Reverse auction shall be conducted by BHEL (through M/s {*Service Provider*}), on pre-specified date, while the bidders shall be quoting from their own offices/ place of their choice. Internet connectivity shall have to be ensured by bidders themselves.

During the RA process if a bidder is not able to bid and requests for extension of time by FAX/ email/ phone then time extension of additional 15 minutes will be given by the service provider provided such requests come before 5 minutes of auction closing time. However, only one such request per bidder can be entertained.

In order to ward-off contingent situation of connectivity failure bidders are requested to make all the necessary arrangements/ alternatives whatever required so that they are able to circumvent such situation and still be able to participate in the reverse auction successfully. Failure of power or loss of connectivity at the premises of bidders during the Reverse auction cannot be the cause for not participating in the reverse auction. On account of this, the time for the auction cannot be extended and neither BHEL nor M/s. {*Service provider*} is responsible for such eventualities.

12. **Proxy bids:** Proxy bidding feature is a pro-bidder feature to safe guard the bidder's interest of any internet failure or to avoid last minute rush. The proxy feature allows bidders to place an automated bid in the system directly in an auction and bid without having to enter a new amount each time a competing bidder submits a new offer. The bid amount that a bidder enters is the minimum that the bidder is willing to offer. Here the software bids on behalf of the bidder. This obviates the need for the bidder participating in the bidding process until the proxy bid amount is decrementally reached by other bidders. When proxy bid amount is reached, the bidder (who has submitted the proxy bid) has an option to start participating in the bidding process.

The proxy amount is the minimum amount that the bidder is willing to offer. During the course of bidding, the bidder cannot delete or change the amount of a proxy bid.

Bids are submitted in decrements (decreasing bid amounts). The application automates proxy bidding by processing proxy bids automatically, according to the decrement that the auction originator originally established when creating the auction, submitting offers to the next bid decrement each time a competing bidder bids, regardless of the fact whether the competing bids are submitted as proxy or standard bids. However, it may please be noted that if a manual bid and proxy bid are submitted at the same instant manual bid will be recognized as the L1 at that instant.

In case of more than one proxy bid, the system shall bid till it crosses the threshold value of 'each lowest proxy bid' and thereafter allow the competition to decide the final L1 price.

Proxy bids are fed into the system directly by the respective bidders. As such this information is privy only to the respective bidder(s).

13. Bidders are advised to get fully trained and clear all their doubts such as refreshing of Screen, quantity being auctioned, tender value being auctioned etc. from M/s. {*Service provider*}.

14. M/s. {*Service provider*}, shall arrange to demonstrate/ train the bidder or bidder's nominated person(s), without any cost to bidders. M/s. {*Service provider*}, shall also explain the bidders, all the business rules related to the Reverse Auction. Bidders are required to submit their acceptance to the terms/ conditions/ modalities before participating in the Reverse Auction in the process compliance form as enclosed. Without this, the bidder will not be eligible to participate in the event.
15. Successful bidder shall be required to submit the final prices (L1) in prescribed format (Annexure – VI) for price breakup, quoted during the Reverse Auction, duly signed and stamped as token of acceptance without any new condition (other than those already agreed to before start of auction), after the completion of auction to M/s. {*Service provider*} besides BHEL within two working days of Auction without fail.
16. Any variation between the final bid value and that in the confirmatory signed price breakup document will be considered as tampering the tender process and will invite action by BHEL as per extant guidelines for suspension of business dealings (as available on www.bhel.com).
17. Bidders' bid will be taken as an offer to execute the work/ supplies the item as per enquiry no. **OS/24-25/8013/IBR DE/03/003, dated 21.05.2024**. Bids once made by the bidder, cannot be cancelled/ withdrawn and bidder shall be bound to execute the work as mentioned above at bidder's final bid price. Should bidder back out and not execute the contract as per the rates quoted, BHEL shall take action as per extant guidelines for suspension of business dealings (as available on www.bhel.com).
18. Bidders shall be able to view the following on their screen along with the necessary fields during Reverse Auction:
 - a. Leading (Running Lowest) Bid in the Auction (only total price of package)
 - b. Bid Placed by the bidder
 - c. Start Price
 - d. Decrement value
 - e. Rank of their own bid during bidding as well as at the close of auction.
19. BHEL's decision on award of contract shall be final and binding on all the Bidders.
20. BHEL reserves the right to extend, reschedule or cancel the Reverse Auction process at any time, before ordering, without assigning any reason, with intimation to bidders.
21. BHEL shall not have any liability to bidders for any interruption or delay in access to the site irrespective of the cause. In such cases, the decision of BHEL shall be binding on the bidders.
22. Other terms and conditions shall be as per bidder's techno-commercial offers and other correspondences, if any, till date.
23. If there is any clash between this business document and the FAQ available, if any, in the website of M/s. {*Service provider*}, the terms & conditions given in this business document will supersede the information contained in the FAQs. Any changes made by BHEL/ service provider (due to unforeseen contingencies) after the first posting shall be deemed to have been accepted if the bidder continues to access the portal after that time.
24. Bidder shall not divulge either his Bids or any other exclusive details of BHEL to any other party. If the Bidder or any of his representatives are found to be involved in Price manipulation/ cartel formation of any kind, directly or indirectly by communicating with other bidders, action *as per extant BHEL guidelines for suspension of business dealings (as available on www.bhel.com)*, shall be initiated by BHEL.

Signature of the Bidder with Stamp

GST COMPLIANCE FOR INDIGENOUS SUPPLIERS

1. In Response to Tenders for Indigenous supplier will be entertained only if the vendor has a valid GSTIN which should be clearly mentioned in the offer. If any specific exemption is available, a declaration with due supporting documents need to be furnished for considering the offer.
2. Supplier shall mention their GSTIN in all their invoices and invoices shall be in the format as specified/prescribed under GST laws. Invoices shall necessarily contain Invoice number (in case of multiple numbering system is being followed for billing like SAP invoice no, commercial invoice no etc., then the Invoice No which is linked/uploaded in GSTN network shall be clearly indicated), item description as per PO, Quantity, Rate, Value, applicable taxes with nomenclature (like IGST, SGST, CGST & UTGST) separately, HSN/ SAC Code, etc.
3. All invoices shall bear the HSN Code for each item separately (Harmonized System of Nomenclature)/ SAC code (Services Accounting Code).
4. A declaration to the effect that all invoice particulars are/were uploaded in the GSTN network/ portal & all tax liability as per GST rules and regulations have been and will be discharged, shall be mentioned in the invoice. If not mentioned in the invoice, a separate declaration shall be submitted as per the requirement of BHEL.
5. All documents like Test Certificate, LR copy, Guarantee/Warranty certificate, work completion certificate, any other document mentioned in PO, shall be sent along with the vehicle/consignment where ever applicable. For all consignments received within the calendar month, input credit will be availed within that month in line with monthly returns filing cycle. In case of any discrepancy in the document or non-submission of documents mentioned in the PO, then BHEL will not be able to accept or account the material, in such case availing of tax credit will be deferred to next month or so.
6. In case of discrepancy in the data uploaded by supplier in the GSTN portal or in case of any shortages or rejection in the supply, then BHEL will not be able to avail the tax credit and will notify the supplier of the same. Supplier has to rectify the data discrepancy in the GSTN portal or issue credit note (details to be uploaded in GSTN portal) for the shortages or rejections in the suppliers, within the calendar month notified by BHEL.
7. For any such delay in availing of tax credit for reasons attributable to supplier (as mentioned above), interest (calculated @ SBI Base Rate + 6%) along with penalty if any will be deducted for the delayed period i.e. from the month of receipt till the month tax credit is availed, from the running bills.
8. Under GST regime, BHEL has to discharge GST liability on LD recovered from suppliers/contractors. Hence applicable GST shall also be recoverable from suppliers/contractors on LD amount. For this Debit note will be issued by BHEL indicating the respective supply invoice number.
9. This is to inform that GST portion of invoice, shall be released only upon Vendor declaring such invoice in his GSTR-1 and receipt of goods and Tax invoice by BHEL and Confirmation of payment of GST thereon by vendor on GSTN portal. Alternatively, BG of appropriate value may be obtained from vendor which shall be valid At least one month after the confirmation of date of payment of GST by vendor on GSTN portal and receipt of Tax invoice and receipt of goods, whichever is later. Above is subject to receipt of goods/service and tax invoice thereof along with vendor declaring invoice in his return and paying GST within timeline prescribed for availing ITC by BHEL.
10. That in case vendor delays Declaring such invoice in his return and GST credit availed by BHEL is denied or reversed subsequently as per GST law, GST amount paid by BHEL towards such ITC reversal as per GST law shall be recoverable from vendor/contractor along with interest levied/ leviable on BHEL.

Note: The above will be followed strictly for processing vendor payments to ensure GST Compliance.

Signature of the Bidder with Stamp

FIRST ANGLE PROJECTION

(ALL DIMENSIONS ARE IN mm)

INVENTORY NO. SIGN. AND DATE REF. DRG. NO. THE INFORMATION ON THIS DOCUMENT IS THE PROPERTY OF BHARAT HEAVY ELECTRICALS LIMITED. IT MUST NOT BE USED DIRECTLY OR INDIRECTLY IN ANY WAY DETRIMENTAL TO THE INTEREST OF THE COMPANY

REV.	DATE	ALTERED	CHECKED	APPD	REV.	DATE	ALTERED	CHECKED	APPD	ADDITIONAL INFORMATION
										STATUS OF DRAWING
										DISTURIBUTION OF PRINTS

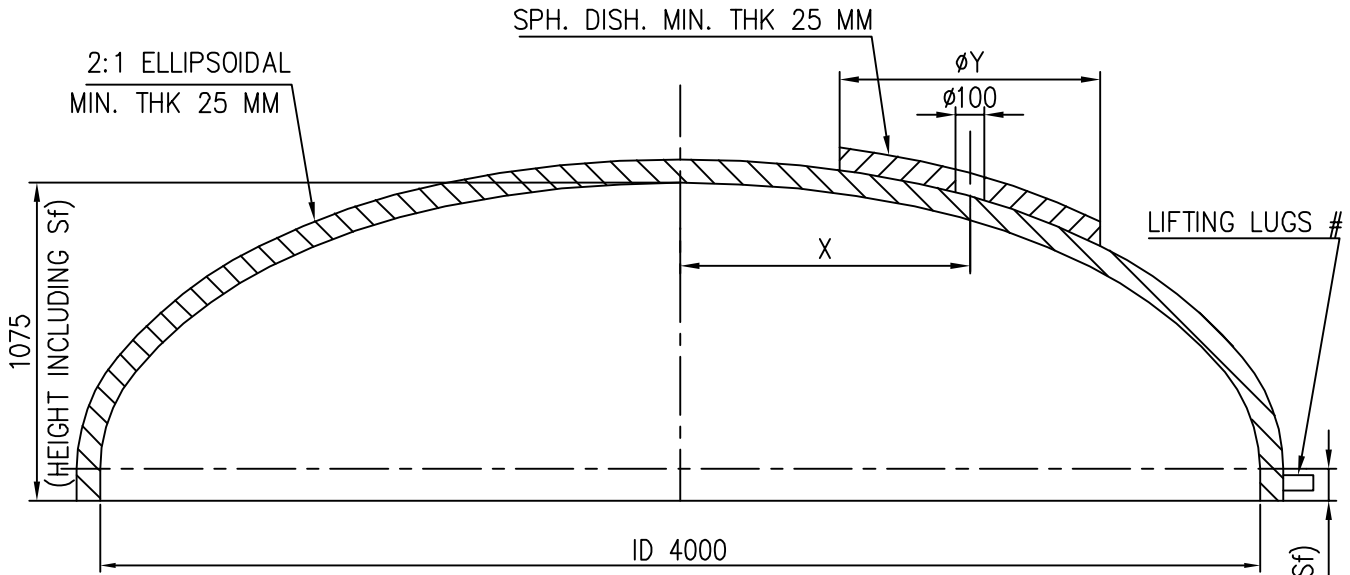

ITEM	Y	X
01	1050	1000
02	700	1200

DESIGN PRESSURE: 14.5 Kg/sq.cm (g)
DESIGN TEMPERATURE: 260° C

NOTES

- MATERIAL SHALL CONFIRM TO SA516 Gr.70 OF ASME SEC-II PART-A YEAR OF EDITION AS PER INDENT/ PO.
- INSPECTION: BY M/s IBR/DOB & BHEL APPROVED TPIA.
- CERTIFICATION: IBR FORM III-C.
- DESIGN CODE: IBR REGULATIONS (CLASS-1 BOILER).
- PLATE SHALL BE UT TESTED BEFORE FORMING (NOT REQUIRED IF ALREADY UT TESTED AT MILLS)
- SPHERICAL DISH SHALL BE OF SEAMLESS CONSTRUCTION & PROFILE SHOULD MATCH WITH DISHED DISHED END OD AS SHOWN IN THE DRG.
- NORMALISING SHALL BE DONE FOR SPHERICAL DISH ALSO AFTER PRESSING.
- TEST COUPON TESTING IS REQUIRED.
- TECHNICAL & DELIVER CONDITIONS: AS PER PRODUCT STANDARD HE51370.

FOR PLATE WELDING REFER DRG. 4-163-10-00744.

3 NOS. LIFTING LUGS TO BE WELDED ON Sf AT 120° AND TO BE DP CHECKED AFTER WELDING.

ITEM NO	DESCRIPTION	DRAWING NO.	MATL. CODE	UNIT Wt.
			MATL. SPEN.	QTY.

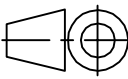
	BHARAT HEAVY ELECTRICALS LTD.		DRN.	B UMA	SIGN.	B UMA	DATE	09.02.24	NO.OF VAR.
	HYDERABAD		CHD.	UMESH MENON	UMESH MENON	UMESH MENON	09.02.24		
			APPD.	UMESH MENON	UMESH MENON	UMESH MENON	09.02.24		
DEPT. HED	GRADE OF TOL.DIM. C/M/F		SCALE	NTS	WEIGHT (KG)	REF. TO ASSY DRG.	ITEM NO.	NO.OF ITEMS	
CODE	405								
TITLE					CARD CODE	DRAWING NO.		REV.	
SPHERICAL DISH WITH 2:1 ELLIPSOIDAL DISHED END						4-163-10-00743			00
					SHEET NO.		1	NO OF SHEETS	1

FIRST ANGLE PROJECTION

(ALL DIMENSIONS ARE IN mm)

INVENTORY NO. SIGN. AND DATE REF. DRG. NO. THE INFORMATION ON THIS DOCUMENT IS THE PROPERTY OF BHARAT HEAVY ELECTRICALS LIMITED. IT MUST NOT BE USED DIRECTLY OR INDIRECTLY IN ANY WAY DETRIMENTAL TO THE INTEREST OF THE COMPANY

REV.	DATE	ALTERED	CHECKED	APPD	REV.	DATE	ALTERED	CHECKED	APPD	ADDITIONAL INFORMATION
										STATUS OF DRAWING
										DISTURIBUTION OF PRINTS

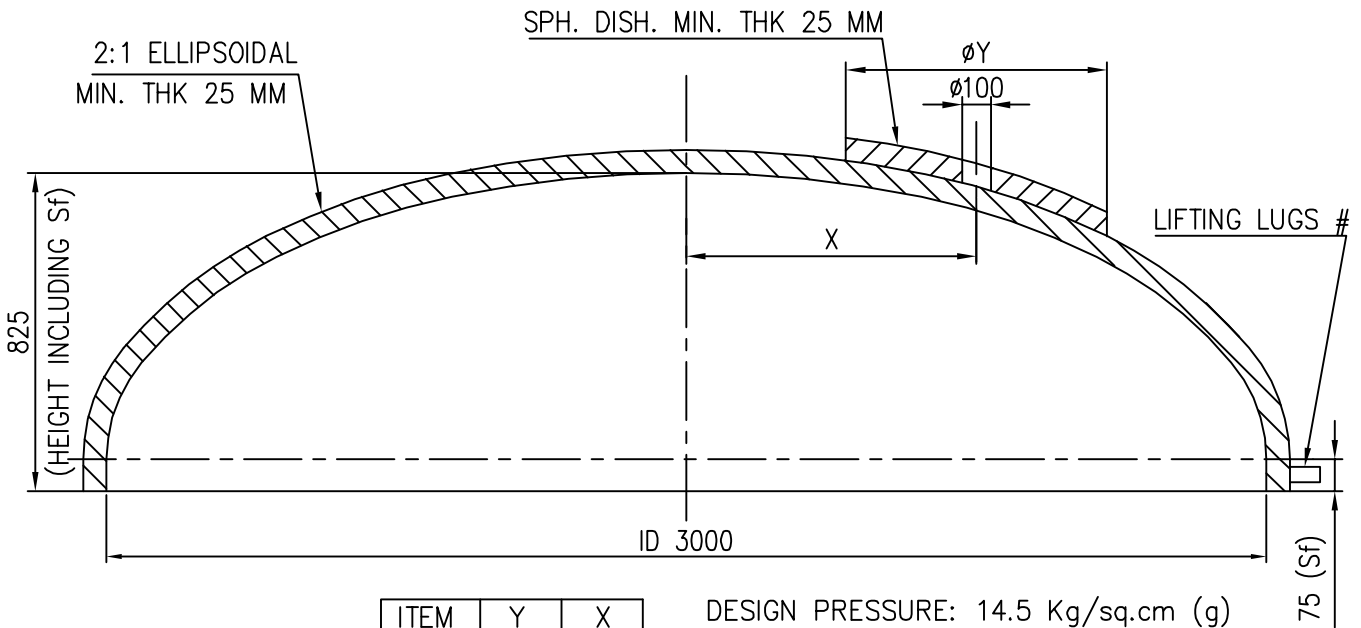

DESIGN PRESSURE: 14.5 Kg/sq.cm (g)
DESIGN TEMPERATURE: 395° C

NOTES

- MATERIAL SHALL CONFIRM TO SA516 Gr.70 OF ASME SEC-II PART-A YEAR OF EDITION AS PER INDENT/ PO.
- INSPECTION: BY M/s IBR/DOB & BHEL APPROVED TPIA.
- CERTIFICATION: IBR FORM III-C.
- DESIGN CODE: IBR REGULATIONS (CLASS-1 BOILER).
- PLATE SHALL BE UT TESTED BEFORE FORMING (NOT REQUIRED IF ALREADY UT TESTED AT MILLS)
- SPHERICAL DISH SHALL BE OF SEAMLESS CONSTRUCTION & PROFILE SHOULD MATCH WITH DISHED DISHED END OD AS SHOWN IN THE DRG.
- NORMALISING SHALL BE DONE FOR SPHERICAL DISH ALSO AFTER PRESSING.
- TEST COUPON TESTING IS REQUIRED.
- TECHNICAL & DELIVER CONDITIONS: AS PER PRODUCT STANDARD HE51370.

FOR PLATE WELDING REFER DRG. 4-163-10-00746.

3 NOS. LIFTING LUGS TO BE WELDED ON Sf AT 120° AND TO BE DP CHECKED AFTER WELDING.

ITEM NO	DESCRIPTION	DRAWING NO.	MATL. CODE	UNIT Wt.
			MATL. SPEN.	QTY.

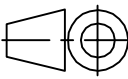
	BHARAT HEAVY ELECTRICALS LTD.		DRN.	B UMA	SIGN.	B UMA	DATE	09.02.24	NO.OF VAR.
	HYDERABAD		CHD.	UMESH MENON	UMESH MENON	UMESH MENON	09.02.24		
			APPD.	UMESH MENON	UMESH MENON	UMESH MENON	09.02.24		
DEPT. HED	GRADE OF TOL.DIM. C/M/F		SCALE	NTS	WEIGHT (KG)	REF. TO ASSY DRG.	ITEM NO.	NO.OF ITEMS	
CODE	405								
TITLE					CARD CODE	DRAWING NO.		REV.	
SPHERICAL DISH WITH 2:1 ELLIPSOIDAL DISHED END						4-163-10-00745			00
					SHEET NO.	1	NO OF SHEETS	1	

MANUFACTURING QUALITY PLAN –
DEAERATOR & FEED STORAGE TANK

PROJECT: 2x800 MW Adani-Bandhaura

		BHARAT HEAVY ELECTRICALS LIMITED R.C.PURAM, HYDERABAD		MANUFACTURING QUALITY PLAN				CUSTOMER: M/S ADANI CONSULTANT: NA PROJECT: 2X800 MW ADANI BANDHAURA BHEL SALE ORDER NO.: BHEL WORK ORDER NO					
				ITEM: DEAERATOR HEATER & FST TYPE: 800 MW		QP No: HYQA/SMQP/ADANI/800/6 Rev. No.: 01 DATE: 10.02.2023 DATE: SHEET 1 of 6							
SL. NO.	COMPONENT & OPERATIONS	CHARACTERISTICS	CLASS	TYPE OF CHECK	QUANTUM OF CHECK	REFERENCE DOCUMENT	ACCEPTANCE NORMS	FORMAT OF RECORD	* D	AGENCY			REMARKS
										M	B	C	

RAW MATERIAL & MAJOR BOIS												
1.0 A INSPECTION AT SUPPLIER'S WORKS												
1.1	SHELL PLATES & PLATES FOR DISHED ENDS	A	CHEMICAL COMPOSITION	MAJOR	CHEMICAL	AS PER SPEC.	SA 516 Gr.70 AND BHEL SPEC	SUPPLIER TC		P		
		B	MECHANICAL PROPERTIES, HEAT TREATMENT	MAJOR	MECH,HT	AS PER SPEC.	SA 516 Gr.70 AND BHEL SPEC	SUPPLIER TC		P		
		C	ULTRASONIC EXAM	MAJOR	NDE	AS PER SPEC.	SA 435	SUPPLIER TC		P		
1.2	NOZZLE PIPES	A	CHEMICAL COMPOSITION	MAJOR	CHEMICAL	AS PER SPEC.	SA 106 Gr.B AND BHEL SPEC	SUPPLIER TC		P	V	
		B	MECHANICAL PROPERTIES, HEAT TREATMENT	MAJOR	MECH,HT	AS PER SPEC.	SA 106 Gr.B AND BHEL SPEC	SUPPLIER TC		P	V	
1.3	SPRAY VALVES	A	CHEMICAL COMPOSITION	MAJOR	CHEMICAL	AS PER SPEC.	AS PER DRAWING	SUPPLIER TC		P	V	
		B	MECHANICAL PROPERTIES	MAJOR	MECH	AS PER SPEC.	AS PER DRAWING	SUPPLIER TC		P	V	
		C	PERFORMANCE TEST FLOW VS PRESSURE DROP CHARACTERISTICS	MAJOR	PERFORMANCE	AS PER SPEC.	AS PER DRAWING	SUPPLIER TC		P	W	
1.4	SHELL DISHED ENDS	A	VERIFICATION CORRELATION OF MATL. SPECIFICATION & TC	MAJOR	VISUAL	100%	SA 516 Gr.70 AND BHEL SPEC ,DRAWING	SUPPLIER TC		P	V	

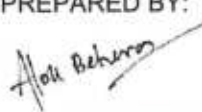
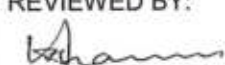
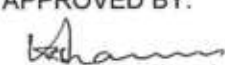
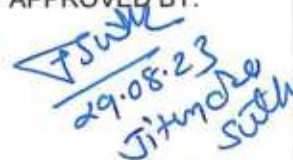
LEGEND: M: MANUFACTURER / VENDOR B: BHEL /BHEL NOMINATED INSPECTION AGENCY, C: CUSTOMER / CUSTOMER NOMINATED INSPECTION AGENCY. P: PERFORM, W: WITNESS V: VERIFICATION, * D: RECORDS IDENTIFIED WITH TICK (✓) SHALL BE ESSENTIALLY INCLUDED IN QA DOCUMENTATION. CHP: CUSTOMER HOLD POINT	PREPARED BY:  ALOK BEHERA MGR/ QA	REVIEWED BY:  B. ASHOK KUMAR AGM / QA	APPROVED BY:  B. ASHOK KUMAR AGM / QA	APPROVED BY:  JITENDRA SUTHI CUSTOMER / CONSULTANT
	Format no. : HYQA/QP/MQP-1 Rev.00			

	BHARAT HEAVY ELECTRICALS LIMITED R.C.PURAM, HYDERABAD	MANUFACTURING QUALITY PLAN				CUSTOMER: M/S ADANI CONSULTANT: NA PROJECT: 2X800 MW ADANI BANDHAURA BHEL SALE ORDER NO.: BHEL WORK ORDER NO		
		ITEM: DEAERATOR HEATER & FST TYPE: 800 MW	QP No: HYQA/SMQP/ADANI/800/6 Rev. No.: 01 DATE: 10.02.2023 DATE: SHEET 2 of 6					

SL. NO.	COMPONENT & OPERATIONS	CHARACTERISTICS	CLASS	TYPE OF CHECK	QUANTUM OF CHECK	REFERENCE DOCUMENT	ACCEPTANCE NORMS	FORMAT OF RECORD	* D	AGENCY			REMARKS
										M	B	C	

1.4	SHELL DISHED ENDS	B	DIMENSIONAL CONFORMITY AFTER FORMING INCLUDING MIN. THICKNESS MEASUREMENT.	MAJOR	MEASRT	100%	SA 516 Gr.70 AND BHEL SPEC ,DRAWING	SUPPLIER TC		P	V		
		C	PT ON KNUCKLE PORTION	MAJOR	NDE	100%	ASME SEC. V ART . 6/ASME SEC.VIII DIV.I APPX.8	SUPPLIER TC		P	V		
		D	RT EXAM OF BUTT WELD JOINT	MAJOR	NDE	100%	DRAWING, ASME SEC. V ART. 2SEC.VIII DIV.I UWS1/52	SUPPLIER TC		P	V		
		E	VERIFICATION OF HT CHART FOR STRESS RELIEVING/NORMALIZING AFTER FORMING	MAJOR	VISUAL	100%	SA 516 Gr.70 AND BHEL SPEC ,DRAWING , ASME SEC.VIII DIV. UCS 56	SUPPLIER TC		P	V		
		F	TESTING OF PRODUCTION TEST COUPON HEAT TREATED ALONG WITH DISHED ENDS.	MAJOR	VISUAL	100%	SA 516 GR. 70 & IBR Reg. 561	SUPPLIER TC		P	V		
1.5	TRAY ASSEMBLY	A	REVIEW OF MATERIAL COMPLIANCE TC	MAJOR	TC VERFN	100 %	DRAWING	SUPPLIER TC		P	V		
		B	DIMENSIONAL INSPN	MAJOR	MEASRT	AS PER SPEC	DRAWING	SUPPLIER TC		P	V		

1.0 B VERIFICATION OF RAW MATERIAL TCS/SUPPLIER TCS AT BHEL WORKS

1.1	SHELL PLATES & PLATES FOR DISHED ENDS	AS PER CL 1.0 A 1.1	MAJOR	TC VERIFN	100 %	SA 516 Gr.70 AND BHEL SPEC ,DRAWING	SUPPLIER'S TC	✓	P	V	✓	
1.2	NOZZLE PIPES	AS PER CL 1.0 A 1.3	MAJOR	TC VERIFN	100 %	SA 106 Gr.B AND BHEL SPEC ,DRAWING	SUPPLIER'S TC	✓	P	V	✓	
1.3	SPRAY VALVES	AS PER CL 1.0 A 1.4	MAJOR	TC VERIFN	100 %	AS PER DRAWING	SUPPLIER'S TC	✓	P	V	✓	
1.4	SHELL DISHED ENDS	AS PER CL 1.0 A 1.5	MAJOR	TC VERIFN	100 %	SA 516 Gr.70 AND BHEL SPEC ,DRAWING	SUPPLIER'S TC	✓	P	V	✓	

LEGEND:
 M: MANUFACTURER / VENDOR B: BHEL /BHEL NOMINATED INSPECTION AGENCY, C: CUSTOMER / CUSTOMER NOMINATED INSPECTION AGENCY.
 P: PERFORM, W: WITNESS V: VERIFICATION, * D: RECORDS IDENTIFIED WITH TICK (✓) SHALL BE ESSENTIALLY INCLUDED IN QA DOCUMENTATION.
 CHP: CUSTOMER HOLD POINT

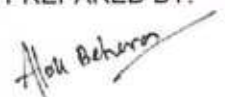
PREPARED BY:

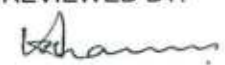
 ALOK BEHERA
 MGR/ QA

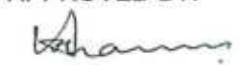
REVIEWED BY:

 B. ASHOK KUMAR
 AGM / QA

APPROVED BY:

 B. ASHOK KUMAR
 AGM / QA

APPROVED BY:

 CUSTOMER / CONSULTANT



BHARAT HEAVY
ELECTRICALS LIMITED
R.C.PURAM, HYDERABAD

MANUFACTURING QUALITY PLAN

ITEM:
DEAERATOR HEATER & FST
TYPE: 800 MW

QP No:
HYQA/SMQP/ADANI/800/6
Rev. No.: 01
DATE: 10.02.2023
DATE: SHEET 3 of 6

CUSTOMER: M/S ADANI
CONSULTANT: NA
PROJECT: 2X800 MW ADANI BANDHAURA
BHEL SALE ORDER NO.:
BHEL WORK ORDER NO

SL. NO.	COMPONENT & OPERATIONS	CHARACTERISTICS	CLASS	TYPE OF CHECK	QUANTUM OF CHECK	REFERENCE DOCUMENT	ACCEPTANCE NORMS	FORMAT OF RECORD	* D	AGENCY			REMARKS
										M	B	C	

1.5	TRAY ASSEMBLY	AS PER CL 1.0 A 1.6	MAJOR	TC VERIFN	100 %	BHEL SPEC ,DRAWING		SUPPLIER'S TC	✓	P	V	V	
-----	---------------	---------------------	-------	-----------	-------	--------------------	--	---------------	---	---	---	---	--

2.0 INPROCESS INSPECTION (INSPECTION AT BHEL WORKS)

2.1 NOZZLE FABRICATION (HEATER & FST)

2.1.1	NOZZLE FABRICATION (HEATER & FST)	A	MATERIAL IDENTIFICATION & TC VERIFICATION FOR PLATES	MAJOR	VISUAL	100%	DRAWING. TC &SPEC	DRAWING. TC &SPEC	IR/ LOG RECORD		P	W	
		B	FIT UP OF L SEAMS	MAJOR	VISUAL & MEASRT.	100%	DRG. ASME SEC. VIII DIV. I & IBR	DRG. ASME SEC. VIII DIV. I & IBR	IR/ LOG RECORD		P	V	
		C	RT OF L SEAM WELD	MAJOR	NDE	AS PER DRG	ASME SEC. V ART. 2 & IBR REG. 561	ASME SEC. VIII DIV I UW51 & IBR REG. 561	NDE REPORT	✓	P	V	V
		D	DIMENSIONAL CONFORMITY	MAJOR	MEASRT.	100%	DRAWING	DRAWING	IR/ LOG RECORD		P	V	V

2.2 SHELL FABRICATION (HEATER & FST)

2.2.1	SHELL FABRICATION	A	MATERIAL IDENTIFICATION & TC VERIFICATION FOR PLATES	MAJOR	VISUAL	100%	DRAWING. TC &SPEC	DRAWING. TC &SPEC	IR/ LOG RECORD		P	W	
		B	VISUAL INSPECTION OF PLATE & EDGE PREPARATION	MAJOR	VISUAL	100%	ASME SEC VIII DIV. I & IBR	ASME SEC VIII DIV. I & IBR	IR/ LOG RECORD		P	W	
		B1	PT OF WELD EDGE PREPARATION	MAJOR	NDE	100%	ASME SEC. V ART. 6	ASME SEC. VIII DIV. 1 APPX.8	NDE REPORT	✓	P	W	V
		C	VERIFICATION OF APPROVED WPS, PQR & WQR	MAJOR	VISUAL	100%	AS PER ASME SEC. IX & IBR	AS PER ASME SEC. IX & IBR	IR/ LOG RECORD	✓	P	V	V
		D	FIT UP OF L & C SEAMS	MAJOR	VISUAL & MEASRT.	100%	DRG. ASME SEC. VIII DIV. I & IBR	DRG. ASME SEC. VIII DIV. I & IBR	IR/ LOG RECORD		P	V	
		D1	PT AFTER BACKCHIPPING	MAJOR	NDE	100%	ASME SEC. V ART. 6	ASME SEC. VIII DIV. 1 APPX.8	NDE REPORT	✓	P	W	V
		E	PT EXAM. OF L & C SEAMS OF THE OUTER SHELL WELDS	MAJOR	NDE	100%	ASME SEC. V ART. 6	ASME SEC. VIII DIV. 1 APPX.8	NDE REPORT	✓	P	W	V
F	RT OF WELDS – L SEAM , C SEAM	MAJOR	NDE	AS PER DRG	ASME SEC. V ART. 2 & IBR REG. 561	ASME SEC. VIII DIV I UW51 & IBR REG. 561	NDE REPORT	✓	P	V	V	REVIEW OF RT FILMS	

LEGEND:

M: MANUFACTURER / VENDOR B: BHEL /BHEL NOMMNATED INSPECTION AGENCY, C: CUSTOMER / CUSTOMER NOMINATED INSPECTION AGENCY.
P: PERORM, W: WITNESS V: VERIFICATION, * D: RECORDS IDENTIFIED WITH TICK (✓) SHALL BE ESSENTIALLY INCLUDED IN QA DOCUMENTATION.
CHP: CUSTOMER HOLD POINT

PREPARED BY:

Alok Behera
ALOK BEHERA
MGR/ QA

REVIEWED BY:

Behara
B. ASHOK KUMAR
AGM / QA

APPROVED BY:

Behara
B. ASHOK KUMAR
AGM / QA

APPROVED BY:

TSJMK
29.08.23
CUSTOMER / CONSULTANT



**BHARAT HEAVY
ELECTRICALS LIMITED**
R.C.PURAM, HYDERABAD

MANUFACTURING QUALITY PLAN

ITEM:
DEAERATOR HEATER & FST
TYPE: 800 MW

QP No:
HYQA/SMQP/ADANI/800/6
Rev. No.: 01
DATE: 10.02.2023
DATE: SHEET 4 of 6

CUSTOMER: M/S ADANI
CONSULTANT: NA
PROJECT: 2X800 MW ADANI BANDHAURA
BHEL SALE ORDER NO.:
BHEL WORK ORDER NO

SL. NO.	COMPONENT & OPERATIONS	CHARACTERISTICS	CLASS	TYPE OF CHECK	QUANTUM OF CHECK	REFERENCE DOCUMENT	ACCEPTANCE NORMS	FORMAT OF RECORD	* D	AGENCY			REMARKS
										M	B	C	

		G	FIT UP OF NOZZLES TO SHELL	MAJOR	VISUAL & MEASRT.	100%	DRG.	DRG	IR/ LOG RECORD		P	V		
2.2.1	SHELL FABRICATION	H	PT / MT EXAM OF NOZZLE TO SHELL WELDS	MAJOR	NDE	100%	DRAWING & ASME SEC. V ART.6 /7	DRAWING & ASME SEC. VIII APPX. 8 / 6	NDE REPORT	✓	P	W	V	
		I	DIMENSIONAL CONFORMITY OF SHELL ASSEMBLY.	MAJOR	MEASRT.	100%	DRAWING	DRAWING	IR/ LOG RECORD	✓	P	V	V	
		K	MECH TEST ON PRODUCTION TEST COUPON	MAJOR	MECH	AS PER IBR	AS PER IBR REGULATION	IR/ LOG RECORD	✓	P	V	V		
2.3	SADDLE FABRICATION, INTERNAL SUPPORT & TRAY ENCLOSURES													
2.3.1	SADDLE FABRICATION & INTERNAL SUPPORT & TRAY ENCLOSURES	A	FIT UP OF PADS & SADDLE TO SHELL - HEATER & FST	MAJOR	VISUAL	100%	DRAWING	DRAWING	IR/ LOG RECORD		P	V		
		B	FIT UP OF INTERNAL CONNECTION -HEATER	MAJOR	VISUAL & MEASRT	100%	DRAWING	DRAWING	IR/ LOG RECORD		P	V		
		C	CHECK FOR CLEARANCE / FIT UP OF TRAY ENCLOSURES- HEATER	MAJOR	VISUAL & MEASRT.	100%	DRAWING	DRAWING	IR/ LOG RECORD		P	V		
		D	VISUAL & DIMENSIONAL EXAM OF TRAY ENCLOSURE-HEATER	MAJOR	VISUAL & MEASRT.	100%	DRAWING	DRAWING	IR/ LOG RECORD		P	W		
		E	PT EXAM OF PADS & SADDLE SUPPORT WELDS-HEATER & FST	MAJOR	NDE	100%	ASME SEC. V ART. 6	ASME SEC. VIII DIV.I APPX. 8	IR/ LOG RECORD	✓	P	V	V	
2.4	FINAL ASSEMBLY - HEATER													
2.4.1	FINAL ASSEMBLY	A	CHECK FOR STACKING OF TRAYS	MAJOR	VISUAL	100%	DRAWING	DRAWING	IR/ LOG RECORD		P	V		
		B	VISUAL & DIMN. CHECK OF COMPLETE TRAY ASSEMBLIES	MAJOR	VISUAL & MEASRT.	100%	DRAWING	DRAWING	IR/ LOG RECORD	✓	P	W	W	
		C	MATCHING OF INTERCONNECTING NOZZLES OF FST AND DEAERATOR HEATER WITH FIXTURE	MAJOR	VISUAL	100%	DRAWING & FIXTURE	DRAWING. & FIXTURE	IR/ LOG RECORD	✓	P	W	W	
		D	FIT UP OF CLOSING DISHED END WITH SHELL	MAJOR	VISUAL & MEASRT	100%	DRAWING	DRAWING	IR/ LOG RECORD		P	V		

LEGEND:
M: MANUFACTURER / VENDOR B: BHEL /BHEL NOMMNATED INSPECTION AGENCY, C: CUSTOMER / CUSTOMER NOMINATED INSPECTION AGENCY.
P: PERFORM, W: WITNESS V: VERIFICATION, * D: RECORDS IDENTIFIED WITH TICK (✓) SHALL BE ESSENTIALLY INCLUDED IN QA DOCUMENTATION.
CHP: CUSTOMER HOLD POINT

PREPARED BY:

Alok Behera
ALOK BEHERA
MGR/ QA

REVIEWED BY:

B. Ashok Kumar
B. ASHOK KUMAR
AGM / QA

APPROVED BY:

B. Ashok Kumar
B. ASHOK KUMAR
AGM / QA

APPROVED BY:

J. S. Jha
29.08.23
CUSTOMER / CONSULTANT

		BHARAT HEAVY ELECTRICALS LIMITED R.C.PURAM, HYDERABAD		MANUFACTURING QUALITY PLAN			CUSTOMER: M/S ADANI CONSULTANT: NA PROJECT: 2X800 MW ADANI BANDHAURA BHEL SALE ORDER NO.: BHEL WORK ORDER NO						
												ITEM: DEAERATOR HEATER & FST TYPE: 800 MW	
SL. NO.	COMPONENT & OPERATIONS	CHARACTERISTICS	CLASS	TYPE OF CHECK	QUANTUM OF CHECK	REFERENCE DOCUMENT	ACCEPTANCE NORMS	FORMAT OF RECORD	* D	AGENCY			REMARKS
										M	B	C	

		E	RT OF CLOSING DISHED END TO SHELL JOINT	MAJOR	NDE	AS PER DRG	ASME SEC. V ART. 2 & IBR REG. 561	ASME SEC. VIII DIV I UW51 & IBR REG. 561	NDE REPORT	✓	P	V	V	REVIEW OF RT FILMS
		F	SOAP SOLUTION TEST FOR RF PADS & SPHERICAL DISH – HEATER & FST	MAJOR	VISUAL	100%	HE-71022/01	HE-71022/01	IR/ LOG RECORD	✓	P	W	V	
2.4.1	FINAL ASSEMBLY	G	PWHT OF L CEAM, C SEAM JOINT- HEATER & FST(IF APPLICABLE)	MAJOR	HT	100%	DRAWING & IBR REG. 562	DRAWING & IBR REG. 562	HT REPORT	✓	P	V	V	
		I	VISUAL & DIMENSIONAL INSPECTION OF FINAL ASSEMBLY – HEATER & FST SECTIONS	MAJOR	VISUA, MEASRT	100%	DRAWING	DRAWING	IR / LOG RECORD	✓	P	V	W	DIA, LENGTH, QUALITY, PERIMETER, NOZZLE ORIENTATION
3.0 HYDRO TEST														
3.1.1	HYDRO TEST/ MARKING OF AXES	A	HYDRO TEST OF DEAERATOR HEATER	CRITICAL	HYDRO	100%	DRG., HY0852061 & IBR REG. 601	DRG., HY0852061 & IBR REG. 601	HYDRO TEST REPORT	✓	P	W	W	
		B	MARKING OF AXES ON ALL SECTIONS OF STORAGE TANK FOR SITE ASSEMBLY	CRITICAL	VISUAL & MEASRT.	-	DRAWING	DRAWING	IR/ LOG RECORD	✓	P	W	W	
4.0 PRE DISAPATCH INSPECTION														
4.1.1	PRE-DESPATCH INSPECTION	A	CLEANLINESS, COMPLETENESS, BLANKING OF ALL OPENINGS STAMPING/NAME PLATE.	MAJOR	VISUAL, MEASRT	100%	HE 71023		IR / LOG RECORD	✓	P	V		
		B	PAINTING	MAJOR	VISUAL, MEASRT	100%	DRG. / SPECN.	DRG. / SPECN.	IR / LOG RECORD	✓	P	V		

NOTES:

1. IN CASE OF ANY INCONSISTENCY BETWEEN QUALITY PLAN AND DRAWING/SPECIFICATION, THE LATTER SHALL PREVAIL.
2. ALL MATERIALS SHALL BE PROCURED AS PER BHEL SPECIFICATION/DRAWING/P.O
3. RAW MATERIAL TCs AND IR AS PER APPROVED QAP SHALL BE FURNISHED FOR REVIEW DURING HYDROTEST.

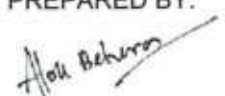
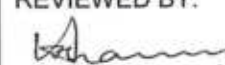
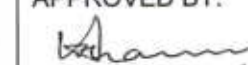
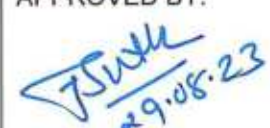
LEGEND: M: MANUFACTURER / VENDOR B: BHEL /BHEL NOMMNATED INSPECTION AGENCY, C: CUSTOMER / CUSTOMER NOMINATED INSPECTION AGENCY. P: PERORM, W: WITNESS V: VERIFICATION, * D: RECORDS IDENTIFIED WITH TICK (✓) SHALL BE ESSENTIALLY INCLUDED IN QA DOCUMENTATION. CHP: CUSTOMER HOLD POINT	PREPARED BY:  ALOK BEHERA MGR/ QA	REVIEWED BY:  B. ASHOK KUMAR AGM / QA	APPROVED BY:  B. ASHOK KUMAR AGM / QA	APPROVED BY:  CUSTOMER / CONSULTANT
Format no. : HYQA/QP/MQP-1 Rev.00				

	BHARAT HEAVY ELECTRICALS LIMITED R.C.PURAM, HYDERABAD	MANUFACTURING QUALITY PLAN					CUSTOMER: M/S ADANI CONSULTANT: NA PROJECT: 2X800 MW ADANI BANDHAURA BHEL SALE ORDER NO.: BHEL WORK ORDER NO						
		ITEM: DEAERATOR HEATER & FST TYPE: 800 MW	QP No: HYQA/SMQP/ADANI/800/6 Rev. No.: 01 DATE: 10.02.2023 DATE: SHEET 6 of 6										
SL. NO.	COMPONENT & OPERATIONS	CHARACTERISTICS	CLASS	TYPE OF CHECK	QUANTUM OF CHECK	REFERENCE DOCUMENT	ACCEPTANCE NORMS	FORMAT OF RECORD	* D	AGENCY			REMARKS
										M	B	C	



NOTES FOR FIXING TRAY ASSEMBLIES & SPRAY VALVES:

1. CLOSING DISHED END SHALL BE ASSEMBLED ONLY AFTER ASSEMBLY OF SPRAY VALVES AND TRAY ASSEMBLIES.
2. SPRAY VALVES ARE TO BE ASSEMBLED PRIOR TO ASSEMBLY OF TRAYS.
3. QC TO ENSURE WELDING OF STOPPERS FOR HOLD DOWN RODS AND ASSEMBLY OF HOLD DOWN ANGLES WITH CLEATS.
4. QC TO ENSURE TACK WELDING OF DOUBLE LOCK NUTS FOR SPRAY VALVE FIXING TO VALVE PLATE.
5. QC TO ENSURE AVAILABILITY OF SPLIT PIN THROUGH THE TOP LOCK NUT AND STEM OF THE SPRAY VALVE BEFORE ASSEMBLY OF SPRAY VALVE.
6. QC TO ENSURE POSITIONING OF SPLIT PIN AT THE BOTTOM OF HOLD DOWN ROD DURING TRAY ASSEMBLY

IBR REQUIREMENTS:

1. AS A STATUTORY REQUIREMENT, DESIGN, CONSTRUCTION AND TESTING SHALL BE AS PER IBR CODE REQUIREMENTS.
2. ALL RELAVANT IBR CERTIFIED TC SHALL BE FURNISHED ALONG WITH OTHER QC DOCUMENTATION AS PER QUALITY PLAN.

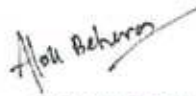
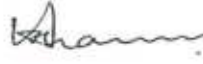
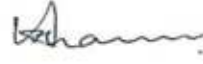
GENERAL LEGENDS					
NDE	NON DESTRUCTIVE EXAMINATION	ASSLY	ASSEMBLY	CHEM	CHEMICAL
UT	ULTRASONIC TEST	QC	QUALITY CONTROL	MECH	MECHANICAL
PT	DYE PENETRANT TEST	TPIA	THIRD PARTY INSPECTION AGENCY	TC	TEST CERTIFICATES
MT/MPI	MAGENTIC PARTICLE INSPECTION	WPS	WELDING PROCEDURE SPECIFICATION	VERFN	VERIFICATION
RT	RADIOGRAPHY TEST	WQR	WELDER QUALIFICATION RECORD	IGC	INTER GRANULAR CORROSSION
MEASRT	MEASUREMENT	PQR	PROCEDURE QUALIFICATION RECORD	HT	HEAT TREATMENT
DIMN	DIMENSION	IR	INSPECTION REPORT	QA	QUALITY ASSURANCE

LEGEND: M: MANUFACTURER / VENDOR B: BHEL /BHEL NOMMNATED INSPECTION AGENCY, C: CUSTOMER / CUSTOMER NOMINATED INSPECTION AGENCY. P: PERORM, W: WITNESS V: VERIFICATION, * D: RECORDS IDENTIFIED WITH TICK (✓) SHALL BE ESSENTIALLY INCLUDED IN QA DOCUMENTATION. CHP: CUSTOMER HOLD POINT	PREPARED BY:  ALOK BEHERA MGR/ QA	REVIEWED BY:  B. ASHOK KUMAR AGM / QA	APPROVED BY:  B. ASHOK KUMAR AGM / QA	APPROVED BY:  CUSTOMER / CONSULTANT
	Format no. : HYQA/QP/MQP-1 Rev.00			