



Bharat Heavy Electricals Limited

Heavy Equipment Repair Plant

Tarna Shivpur Varanasi-221003

website: <https://herp.bhel.com>

Enquiry Number : **E-RC-304-26-0078-61-1** Date : **11/Jun/2026**

Enquiry For Material :-

Sl No	Material Description	Material Code	Quantity	Unit
1	SHIM (HY-101.09) (MFS ASSLY) AS PER DRG. 46116200694/02 WITH MATL AS PER SPECN. IS:1079	RV1016214030	15.0	NOS.
2	SHIM SET (JR.BRG.HSG.) 'VAR-01' (HY-215.A.07) AS PER SPECN. BA55016/01 (OD 559 MM & ID 436 MM) WITH MATL AS PER SPECN. IS:1079 & IS:1993	RV1019813059	200.0	SET.
3	SHIM SET (JR.BRG.KPR.) 'VAR-02' (HY-215.A.08) AS PER SPECN. BA55017/01 WITH MATL AS PER SPECN. IS:1079 & IS:1993	RV1019813067	100.0	SET.
4	SHIM SET (PUMP HSG COVER) (HY-71.01) AS PER SPECN. BA55020/01 WITH MATL AS PER SPECN. IS:1079 & IS:1993	RV1019813113	20.0	SET.
5	SHIM (DUST GUARD) (HY-207.01.05) AS PER DRG. 46118000680/04 WITH MATL. AS PER SPECN. AA10114/07	RV1019813148	30.0	SET.
6	SHIM SET (OIL PUMP KEEPER) HY-71.02 AS PER SPECIFICATION BA-55017/01, VAR-01 WITH MATL. STEEL IS:1079 & IS: 1993	RV1019813156	20.0	SET.
7	SHIM SET (TH.BRG.TO COVER) (HY-71.03) AS PER SPECN. BA55019/02 WITH MATL. IS:1079 & IS:1993	RV1019813164	75.0	SET
8	SHIM SET (HY-341.06) AS PER DRG. 36100000682/02 WITH MATL. AS PER SPECN. AA10113/07	RV1019813334	150.0	SET
9	SHIM SET- JRN. BRG. HSG. (HY-905.01) (14 HALVES/SET) AS PER DRG. 46108802062/03 WITH MATL AS PER SPECN. AA10113/07	RV1019813342	50.0	SET
10	SHIM SET- UPPER BRG. KEEPER (HY-341.07) - AS PER DRG. 36100000679/02 WITH MATL. AS PER SPECN. AA10113/07	RV1019813350	100.0	SET
11	SHIM SET - AIR SEAL RING (HY-341.08) AS PER DRG. 36100000680/02 WITH MATL. AS PER SPECN. AA10113/07	RV1019813369	100.0	SET
12	SHIM SET (G.ROLL) (HY-802.14) (16 NOS/SET) AS PER DRG. 46108000961/01 WITH MATL AS PER SPECN. IS:1993	RV1019813385	25.0	SET
13	SHIM SET - JOURNAL BEARING KEEPER (HY-902.11) (9 NOS/SET) AS PER DRG. 46109600468/02 WITH MATL. AA10114/07	RV1019813431	50.0	SET
14	SHIM SET- JOURNAL BEARING KEEPER(HY-905.03) (04 NOS/SET) AS PER DRG. 46108802005/02 WITH MATL. AS PER SPECN. AA10131/05	RV1019831014	40.0	SET
15	SHIM SET - AIR SEAL RING (8 HALVES/SET) (HY-1102.16) - AS PER DRG. 26100402263/02 WITH MATL AS PER SPECN. AA10114/07	RV1019921323	40.0	SET
16	SHIM SET - JOURNAL BEARING KEEPER (8 NO./SET) (HY-312.A.24) - AS PER DRG. 36100000678/01 WITH MATL. AS PER SPECN. AA10113/07	RV1019921331	100.0	SET
17	SHIM SET - JOURNAL HEAD SKIRT (HY-903.19) (18 NOS/SET) AS PER DRG. 36108802027/02 WITH MATL AS PER SPECN. AA10131/05	RV9019813440	25.0	SET
18	SHIM SET (HY-341.05) AS PER DRG. 36110000520/02 WITH MATL AA10131/05	RV9717283028	40.0	SET

Remarks

(A) SCOPE OF SUPPLY:-

1. THIS ENQUIRY HAS BEEN RAISED FOR ENTERING INTO FRAMEWORK AGREEMENT WITH VENDORS FOR SHIM SETS ITEMWISE. SEPARATE PO WILL BE GIVEN TIME TO TIME AS PER REQUIREMENT UNDER THIS RC. ITEM QUANTITY MENTIONED IN THE ENQUIRY IS TENTATIVE & IT MAY INCREASE OR DECREASE AS PER OUR FINAL REQUIREMENT.
 2. RATES OF ITEMS AGAINST FA WILL BE FIRM & VALID FOR ORDERING FOR A PERIOD OF ONE YEAR FROM THE DATE OF AGREEMENT. PRICE VARIATION CLAUSE (PVC) IS NOT ACCEPTABLE.
- AFTER FINALIZATION OF RATE CONTRACT, PO QUANTITY WILL BE PLACED AS PER REQUIREMENT.

(B) SUPPLY CONDITION :

1. ITEMS TO BE SUPPLIED AT BHEL HERP STORES.
2. INSPECTION TO BE CARRIED OUT AT HERP.

(C) TECHNICAL DELIVERY CONDITION :

1. MATERIAL SHOULD BE AS PER SPECN. MENTIONED AGAINST DESCRIPTION.
2. DIMENSIONS AND TOLERANCES TO BE MAINTAINED AS PER DRG.
3. ALL THE NOTES MENTIONED ON THE DRG. SHOULD BE STRICTLY FOLLOWED.

(D) TEST CERTIFICATE : REQUIRED FOR CHEMICAL PROPERTIES OF RAW MATL.

(E) GUARANTEE CERTIFICATE : REQUIRED FOR 24 MONTHS AGAINST ANY MANUFACTURING DEFECTS FROM THE DATE OF RECEIPT AT BHEL HERP

(F) PACKING INSTRUCTION : ITEM TO BE SUPPLIED IN PROPERLY PACKED CONDITION (PREFERABLY IN WOODEN BOXES). NO BLACK PAINT TO BE APPLIED ON THE SURFACE OF THE SHIMS, ONLY GREASE TO BE APPLIED ON THE SURFACES. USE OF POLYTHENE IS STRICTLY PROHIBITED FOR PACKING.

(G) ITEM WISE MAXIMUM QTY IN EACH LOT (WHICH MAY BE REQUIRED IN A PARTICULAR ORDER) WILL BE 20NOS. THERE WILL BE A GAP OF 01 MONTH BETWEEN TWO CONSECUTIVE LOTS.

(H) DELIVERY IS WITHIN 120 DAYS FROM DATE OF PO FOR FIRST LOT.HOWEVER EARLY DELIVERY IS ALSO ACCEPCTABLE.

(I)REVERSE AUCTION (RA) WILL BE CONDUCTED.

(J) IN ORDER TO AVAIL BENEFITS OF MSE UNDER VARIOUS CATEGORIES, ALL BIDDERS FALLING UNDER MSE CATEGORY SHALL FURNISH THE FOLLOWING DETAILS & SUBMIT DOCUMENTARY EVIDENCE/ GOVT. CERTIFICATE ETC. IN SUPPORT OF THE SAME ALONG WITH THEIR TECHNO-COMMERCIAL OFFER AS PER ANNEXURE - MSES 2012 REV 01 ATTACHED.

SPECIAL TERMS AND CONDITIONS:

1. ALL OTHER TERMS AND CONDITIONS SHALL BE AS PER THE GTC ATTACHED WITH ENQUIRY (PARTY HAVE TO STRICTLY ADHERE THESE TERMS & CONDITIONS).

List of required Quality Documents along with supply:-

S.No	Material Code	Material Description	Documents Description
1	RV1019813334	U.J.HOUSING SHIM SET - HY-341.06 (10 NO./SET)	<ol style="list-style-type: none"> 1. Dimension Report 2. Guarantee Certificates 3. Test Certificates Chemical Properties 4. Test Certificates-Mechanical Properties
2	RV1019921331	SHIM SET - JOURNAL BEARING KEEPER (8 NO./SET) HY-312.A.24	<ol style="list-style-type: none"> 1. Dimension Report 2. Test Certificates-Mechanical Properties 3. Test Certificates Chemical Properties 4. Guarantee Certificates

Note : Any other document mentioned in QP/Drg/Spec will also be applicable

PQR for Critical Regular Direct Mill items

PQR Ref No: PQR/24-25/ Critical Regular Direct Mill items	Date: 23.08.2024
Rev No: 04	Review Date: 29.03.2026
PQR Revision Date: 29.03.2026	

Sl. No.	BHEL Terms	Supplier's Compliance YES/NO
1	Offers are accepted from:	
1.a	Only Manufacturer's Offers shall be considered for the Tender Enquiry.	
2	Supplier shall give list of In-House Facilities:	
2.a	Vendor shall have in-House necessary Manufacturing facilities required for manufacturing and supply of item/s as per drawing/specification.	
2.b	BHEL reserves right to visit the Works of the Manufacturer for Physical verification of the Manufacturing facilities (as declared by them) and assessment of their Quality systems during Technical Evaluation of the Offers.	
2.c	Bidders shall submit detailed Manufacturing process Plan along with the Technical Offer.	
3	Experience:	
3.a	Bidders shall submit the necessary documents proving their Experience in Supplying same or similar items to any Power Plant Equipment Manufacturer (Original Equipment Manufacturer)/ Defence Equipment Manufacturer (Original Equipment Manufacturer) (Govt or PSU)/AeroSpace Equipment Manufacturer (Original Equipment Manufacturer) (Govt or PSU)/Indian Railway during last Five (05) years from the date of Enquiry. Documentary evidences to be submitted in the form of Executed Purchase Order copies along with Material Acceptance Report and drawings/specifications of the supplied item/items. No relaxation in experience shall be given to MSEs & Notified start-ups.	
3.b	BHEL reserves right to verify the details from the Bidder's customers based on Documents submitted as a part of past experience. BHEL may ask for other relevant documents in line with above to review the capacity and capability of vendor with respect to enquired items.	
4	Financial Capability:	
4.a	Turn Over:- Turn over of Non-MSE vendors should be 100% of tender value. Relaxation for MSE vendors/ Notified Start-Ups on turn over will be as per MSME guidelines. Latest UDYAM Certificate required for MSE status.	
4.b	Applicable only for Non-MSE vendors: Audited balance Sheet and Profit and Loss account Statement of last three consecutive year (with UDIN) required along with part-1 bid. Or A CA Certified Consolidated summary (with UDIN) for last 3 consecutive years having annual turn over and Profit and Loss to be enclosed along with Part-1 bid . For Vendors having Turn over less than 1 crore in any of the financial year, CA certified Financial Turn over and Profit Loss (with UDIN) may be accepted for that year only.	
5	Vendor past Performance	
5.a	Any vendor who is on HOLD in BHEL HERP shall not be considered, and their offer shall be adjudged technically not suitable.	

Note-1: Non Submission of the above requested documents/non compliance to the above points is liable for rejection of the Offers without any further Notice/Intimation to the Bidder and no correspondence will be entertained at later stage.

Note-2: "Similar items" means items having same or similar Constructional feature, manufacturing process, similar nature of use, etc.

**GENERAL COMMERCIAL TERMS & CONDITIONS OF ENQUIRY
(FOR INDIAN VENDORS)**

Amendment- 27
ANNEXURE-A

**ITEM DESCRIPTION:
ENQUIRY NO:**

SI No	BHEL STANDARD TERMS & CONDITIONS	Confirmation of supplier (Yes/No)
1.	A) OFFER MUST BE SUBMITTED IN TWO PART BID SYSTEM NAMELY TECHNO-COMMERCIAL BID & PRICE BID FOR THE ITEM AS PER ENQUIRY IN SEPARATE SEALED COVERS: (I) TECHNO – COMMERCIAL BID & (II) PRICE BID SHOULD BE CLEARLY SUPERSCRIBED THE ENQUIRY NO. AND DUE DATE ON THE ENVELOPES. (B) UN-PRICED OFFER WITH TECHNICAL BID IS REQUIRED TO BE FURNISHED BY THE VENDOR. TECHNICAL OFFER SHOULD CLEARLY REFLECT AT LEAST OUR MATERIAL CODE, ITEM DESCRIPTION & QUANTITY. (C) THE DIFFERENCE BETWEEN “UN-PRICED OFFER” AND “PRICED OFFER” SHOULD BE ONLY THE PRICES WHEREVER APPLICABLE. THE RATES AND AMOUNT SHOULD BE CLEARLY WRITTEN IN FIGURES AND WORDS BOTH WITHOUT ANY CUTTING / OVERWRITING. (D) IMPORTANT POINT FOR VENDOR WHO HAVE NOT SUBMITTED THE SRF (SUPPLIER REGISTRATION FORM) SO FAR: THE VENDORS, WHO HAVE NOT SUBMITTED THE SRF SO FAR, MUST SUBMIT THE SAME ALONG WITH PART- 1 BID. THE SRF TO BE DOWNLOADED FROM WWW.BHEL.COM OR https://herp.bhel.com .	
2.	BID SHOULD BE FREE FROM CORRECTION, OVERWRITING, USING CORRECTIVE FLUID, ETC. ANY INTERLINEATION , CUTTING , ERASURE OR OVERWRITING SHALL BE VALID ONLY IF THEY ARE ATTESTED UNDER FULL SIGNATURE(S) OF PERSON(S) SIGNING THE BID ELSE BID SHALL BE LIABLE FOR REJECTION .	
3.	YOUR TECHNO COMMERCIAL BID SHOULD MENTION THAT PRICE BID HAS BEEN SENT IN A SEPARATE ENVELOPE GIVING ITS REFERENCE.	
4.	VENDOR TO ENSURE THAT ITEM & QUANTITY MENTIONED IN THE OFFERS ARE EXACTLY SAME AS PER ENQUIRY. IF ANY DEVIATION IS THERE PARTY MUST MENTION SPECIFIC HEREWITH OTHERWISE BHEL SHALL CONSIDER THAT ITEM & QUANTITY AS REQUIRED IN ENQUIRY.	
5.	PLEASE MAKE SURE THAT THERE IS NO DISCREPANCY IN BETWEEN ACCEPTED TERMS & CONDITIONS MENTIONED IN THE CHECK LIST AND QUOTATION SUBMITTED BY VENDOR AND IF FOUND SO THEN THE TERMS & CONDITIONS WHICH ARE BENEFICIAL TO BHEL WOULD ONLY BE CONSIDERED.	
6.	THE TENDER RECEIVED AFTER 14:00 HRS ON THE DUE DATE WILL NOT BE CONSIDERED.	
7.	PART-I CONTAINING THE TECHNO-COMMERCIAL BID WILL BE OPENED ON THE DATE AND TIME SPECIFIED IN THE ENQUIRY, IN THE PRESENCE OF THOSE TENDERERS WHO WISH TO ATTEND. PART-II i.e., PRICE BID WILL BE OPENED ONLY OF THOSE BIDDERS WHO ARE FOUND TECHNO-COMMERCIALY SUITABLE AFTER SCRUTINY OF THEIR PART-I OFFERS.	
8.	NO REVISED OFFERS WILL BE ACCEPTED UNLESS ASKED BY BHEL AFTER OPENING OF PART-1 BID IN ANY CASE.	
9.	THE RATE OF GST SHOULD BE CLEARLY MENTIONED IN THE OFFER.	
10.	VALIDITY OF OFFER SHOULD BE MINIMUM 90 DAYS FROM THE DATE OF TECHNO - COMMERCIAL BID OPENING OR 60 DAYS FROM THE REVERSE AUCTION DATE.	
11.	BHEL RESERVES THE RIGHT TO REJECT THE OFFER, WHICH IS HAVING DEVIATIONS TO THE TERMS AND CONDITIONS GIVEN IN THE TENDER ENQUIRY.	
12.	PRICING TERMS: PRICES ONCE QUOTED SHALL REMAIN FIRM WITHIN THE VALIDITY OR ANY EXTENSION THEREOF FOR PLACEMENT OF ORDER, TILL COMPLETE EXECUTION OF THE ORDER, WITHOUT ANY ESCALATION/INCREASE FOR ANY REASON, WHATSOEVER, UNLESS SPECIFICALLY PROVIDED FOR IN THE ENQUIRY & PO. IN CASE OF FOREIGN VENDORS, THE QUOTED PRICE SHALL BE TAKEN AS INCLUSIVE OF THIRD PARTY INSPECTION AND TESTING CHARGES AS CALLED FOR IN THE NIT.	
13.	BID EVALUATION: UNLESS SPECIFIED IN THE TENDER, VENDOR MUST NOTE THAT BHEL WILL ARRIVE THE L1 STATUS FOR EACH ITEM ON LANDED COST BASIS. ACCORDINGLY, ORDER SHALL BE PLACED ON LOWEST BIDDER ON INDIVIDUAL ITEM BASIS ONLY, UNLESS BHEL ASK FOR TERMS OTHER THAN THIS ON EXCEPTION BASIS. IN THE COURSE OF EVALUATION, IF MORE THAN ONE BIDDER HAPPENS TO OCCUPY L-1 STATUS, EFFECTIVE L-1 WILL BE DECIDED BY SOLICITING DISCOUNTS FROM THE RESPECTIVE L-1 BIDDERS. IN CASE MORE THAN ONE BIDDERS HAPPENS TO OCCUPY THE L-1 STATUS EVEN AFTER SOLICITING DISCOUNT, THE L-1 BIDDER SHALL BE DECIDED BY A TOSS/DRAW OF LOTS, IN THE PRESENCE OF THE RESPECTIVE BIDDER(S) OR THEIR REPRESENTATIVE(S). RANKING WILL BE DONE ACCORDINGLY. BHEL'S DECISION IN SUCH SITUATION SHALL BE FINAL AND BINDING.	
14.	TERMS OF DELIVERY: I. FOR INDIGENOUS SUPPLIERS: THE TERMS OF DELIVERY SHOULD BE QUOTED ON F.O.R. DESTINATION (BHEL HERP STORES VARANASI) BASIS ONLY (i.e. FREIGHT & INSURANCE ON VENDOR'S ACCOUNT ONLY). IF ANY BIDDER STILL QUOTES OTHER DELIVERY TERM IN PLACE OF BHEL HERP STORES, THEIR OFFER MAY NOT BE CONSIDERED FOR FURTHER PROCESSING. IT MUST BE SPECIFICALLY NOTED.	
15.	IF ANY INDIAN SUPPLIERS ARRANGE SUPPLY FROM FOREIGN PRINCIPLES/WORKS, TERMS OF DELIVERY SHOULD BE QUOTED ON CIF JNPT MUMBAI (INDIA) SEA PORT BASIS ONLY (i.e. FREIGHT & INSURANCE ON VENDOR'S ACCOUNT UPTO JNPT MUMBAI (INDIA) SEA PORT) OR CFR MUMBAI AIRPORT. HOWEVER FREIGHT CHARGES AS PER BHEL TRANSPORT CONTRACT FROM JNPT MUMBAI SEAPORT/MUMBAI AIRPORT TO BHEL VARANASI FOR EACH ITEM WILL BE LOADED AT THE TIME OF TOTAL LANDED COST CALCULATION (RATE OF BHEL TRANSPORT CONTRACT SHALL BE AS APPLICABLE RATE ON PART-1 BID OPENING DATE).	
16.	INSURANCE CHARGES SHALL BE TO VENDOR'S ACCOUNT ONLY IF PRICE QUOTED ON BHEL HERP STORES BASIS. IN CASE PRICE QUOTED IS ON CIF JNPT MUMBAI BASIS/ CFR MUMBAI AIRPORT BASIS, INSURANCE UP TO CIF JNPT MUMBAI/ MUMBAI AIRPORT SHALL BE IN VENDOR ACCOUNT.	
17.	PAYMENT TERMS: I.FOR MSES VENDORS: 100% AGAINST SRV WITHIN 45 DAYS THROUGH EFT (ELECTRONIC FUND TRANSFER) FROM THE DATE OF RECEIPT OF MATERIAL (DATE OF SRV) AT BHEL HERP VARANASI STORES AS PER PO. II.FOR MEDIUM ENTERPRISES VENDORS: 100% AGAINST SRV WITHIN 60 DAYS THROUGH EFT (ELECTRONIC FUND TRANSFER) FROM THE DATE OF RECEIPT OF MATERIAL (DATE OF SRV) AT BHEL HERP VARANASI STORES AS PER PO. III. FOR NON- MSME: 100% AGAINST SRV WITHIN 90 DAYS THROUGH EFT (ELECTRONIC FUND TRANSFER) FROM THE DATE OF RECEIPT OF MATERIAL (DATE OF SRV) AT BHEL HERP VARANASI STORES AS PER PO. IV.BHEL HERP WILL MAKE PAYMENTS IN TWO PARTS: - PART-I: BASIC INVOICE VALUE AND ALL OTHER CHARGES (EXCEPT GST AMOUNT) WILL BE PAID AS PER P.O. PAYMENT TERMS. PART-II: GST PORTION OF INVOICE VALUE WILL BE PAID ONLY AFTER FULFILLING FOLLOWING CONDITIONS: (A) PAYMENT OF GST AMOUNT INTO GOVT. ACCOUNT BY SUPPLIER AGAINST INVOICE RAISED TO BHEL. (B) FILING OF GST RETURN (C) DISPLAY OF GST CREDIT AGAINST BHEL GSTIN NO.09AAACB4146P2ZC IN GSTR-2B ON GSTN PORTAL. NOTE: 1. PAYMENT WILL BE MADE AFTER ACCEPTANCE OF MATERIAL. 2. ADVANCE PAYMENT IS NOT ACCEPTABLE BY BHEL HERP VARANASI IN ANY CASE. 3. IF ANY SUPPLIER FALLS UNDER “NON MSE” OR “NON MEDIUM” CATEGORY AT THE TIME OF PO PLACEMENT AND IF PARTY DOES NOT INFORM BHEL REGARDING CHANGE IN THEIR STATUS BEFORE PROCESSING OF THE PAYMENT, THEIR PAYMENT TERM WILL BE CONSIDERED AS NON MSME SUPPLIER WITHOUT ANY FURTHER INTIMATION. IF SUCH SUPPLIER INFORM BHEL OR BHEL GETS UPDATED ON THEIR OWN ABOUT PARTY'S STATUS CHANGE (WHEN PARTY BECOMES MSME FROM NON-MSME) BEFORE PROCESSING OF THE PAYMENT, PARTY'S PAYMENT TERM WILL BE CHANGED AS PER APPLICABLE STATUS. ACCORDINGLY, PURCHASING OFFICER WILL CHANGE PAYMENT TERMS IN THE APPLICABLE PO/S ALSO.	
18.	LOADING OF PAYMENT TERM: IN CASE OF DEVIATION, LOADING @ REPO RATE+4% (AS ON PART-1 OPENING DATE) SHALL BE LOADED WHILE ARRIVING AT LANDED COST TO BHEL.	
19.	LIQUIDATED DAMAGES/ LATE DELIVERY (LD) PENALTY CLAUSE: SUBJECT TO FORCE MAJEURE CONDITIONS, FAILURE TO SUPPLY WITHIN PURCHASE ORDER DELIVERY SCHEDULE WILL MAKE THE SUPPLIER LIABLE TO AN UNCONDITIONAL PENALTY OF 0.5 % PER WEEK OR PART THEREOF SUBJECT TO THE MAXIMUM OF 10% OF THE UNDELIVERED PURCHASE ORDER VALUE EXCLUDING TAXES & DUTIES. NO GRACE PERIOD SHALL BE GIVEN.	

**GENERAL COMMERCIAL TERMS & CONDITIONS OF ENQUIRY
(FOR INDIAN VENDORS)**

Amendment- 27
ANNEXURE-A

20.	<p>LOADING OF LIQUIDATED DAMAGES (LD): DEVIATION TO ABOVE STANDARD PENALTY CLAUSE, MAXIMUM LOADING OF 10% (IN CASE OF NON ACCEPTANCE OF LD CLAUSE) OR PART THEREOF (IN CASE OF PART ACCEPTANCE OF LD) SHALL BE LOADED WHILE ARRIVING LANDED COST TO BHEL.</p> <p>LOADING OF DELIVERY TERM: FURTHER IF DEVIATION IS FOUND IN THE ACCEPTED DELIVERY TERM AS WELL AS ACCEPTED PENALTY TERM, SUITABLE LOADING BASED ON TRANSPORTATION TIME TO BE TAKEN SHALL BE LOADED WHILE ARRIVING LANDED COST TO BHEL HERP STORES WHICH MAY BE AS BELOW:</p> <p>(i) 1% OF THE BASIC COST FOR INDIAN SUPPLIERS,</p>	
21.	<p>DELIVERY PERIOD: VENDOR SHOULD STRICTLY QUOTE THE DELIVERY PERIOD AS MENTIONED IN NIT.</p>	
22.	<p>IF ANY VENDOR DOES NOT SUPPLY THE ITEM WITHIN THE PURCHASE ORDER DELIVERY PERIOD, BHEL MAY/MAY NOT ACCEPT THE SUPPLY AT ITS SOLE DISCRETION.</p>	
23.	<p>BANK GUARANTEE: THE COST OF BHEL FREE ISSUE MATERIALS PER SET/PER ASSEMBLY AND TOTAL COST OF FIM FOR THE ENQUIRY ARE MENTIONED IN NIT. IN THIS REGARD:</p> <p>1 (a). PARTY WILL HAVE TO SUBMIT EQUAL AMOUNT OF SECURITY DEPOSIT (IN THE FORM OF 10% BG/FDR/DD/CHEQUE/BANK TRANSFER AND 90% INDEMNITY BOND) TOWARDS THE COST OF BHEL MATERIALS TO BE ISSUED TO THEM BEFORE THE ISSUE OF BHEL MATERIALS TO THEM. AT ANY POINT OF TIME, PROPORTIONATE SECURITY DEPOSIT OF TOTAL/CUMMULATIVE MATERIAL VALUE SHOULD BE MAINTAINED.</p> <p>(b) IN CASE OF TRIAL/DEVELOPMENTAL ORDER, PARTY WILL HAVE TO SUBMIT 30% BG/FDR/DD/CHEQUE/BANK TRANSFER AND 70% INDEMNITY BOND TOWARDS THE COST OF BHEL FIM.</p> <p>2. BHEL MAY ASK THE SUPPLIER FOR SUBMISSION OF FULL SECURITY DEPOSIT AMOUNT OR PART DEPENDING UPON THE AVAILABILITY OF FREE ISSUE MATERIALS AT OUR END.</p> <p>3. PARTY MUST HAVE TO SUBMIT THE SAME WITHIN 02 WEEK TIME FROM THE DATE OF WRITTEN INTIMATION BY BHEL WITHOUT FAIL OTHERWISE IT WOULD TREATED AS FAILURE OF HONOURING PO TERMS AND ACCORDINGLY BHEL MAY CANCEL THE PURCHASE ORDER AND INITIATE ALTERNATE PROCUREMENT ACTION AT SUPPLIER RISK & COST.</p> <p>4. IN CASE OF ABSENCE OF DESIRED SECURITY DEPOSIT AT BHEL END AND ALSO NON RESPONSE OF POINT NO. 03 AS ABOVE,</p> <p>I. BHEL MAY HOLD THE PENDING PAYMENTS OF SUPPLIER AVAILABLE AT BHEL ON THEIR CONSENT.</p> <p>II. IF NO PAYMENT IS PENDING AT BHEL END, ACTION FOR ALTERNATE PROCUREMENT ACTION MAY BE INITIATED.</p> <p>5. THE FORMAT OF BG AND IB SHALL BE PER ATTACHED ANNEXURE-BG/FIM AND IB-FIM RESPECTIVELY</p> <p>6. PARTY SHALL HAVE TO ARRANGE FURNISHING OF THE SFMS CODE ALONG WITH THE BG.</p>	
24.	<p>TRANSPORTATION CHARGES FOR SENDING BHEL FREE ISSUE MATERIALS (FIM) TO THE PARTY WORKS WILL BE BORNE BY BHEL ONLY. THE FREIGHT CHARGES FOR SENDING THE BHEL FIM FROM HERP STORES TO PARTY'S WORK FOR EACH ITEM WILL BE LOADED AS PER BHEL TRANSPORT CONTRACT AT THE TIME OF TOTAL LANDED COST CALCULATION (RATE OF BHEL TRANSPORT CONTRACT SHALL BE AS APPLICABLE RATE ON PART-1 BID OPENING DATE). HOWEVER, VARANASI/LOCAL BASED VENDORS WILL LIFT THE FIM FROM BHEL STORES AND BORNE ITS TRANSPORTATION CHARGES.</p>	
25.	<p>IF BHEL ISSUES FREE ISSUE MATERIALS TO THE SUPPLIER, IT MUST BE RETURNED WITHIN THE TIME LIMIT AS PRESCRIBED IN GST LAW (PRESENTLY 01 (ONE) YEAR FROM THE DATE OF FREE ISSUE DATE) TO COMPLY THE GST RULES. IF ANY VENDOR DOES NOT RETURN THE BHEL FREE ISSUE MATERIALS AS MENTIONED ABOVE, THE FINANCIAL IMPLICATION ON ACCOUNT OF THIS, IF ANY, SHALL BE RECOVERED FROM THE PARTY BILLS.</p>	
26.	<p>REVERSE AUCTION: BHEL SHALL BE RESORTING TO REVERSE AUCTION (RA) (GUIDELINES AS AVAILABLE ON WWW.BHEL.COM) FOR THIS TENDER. RA SHALL BE CONDUCTED AMONG ALL THE TECHNO-COMMERCIALY QUALIFIED BIDDERS.</p> <p>PRICE BIDS OF ALL TECHNO-COMMERCIALY QUALIFIED BIDDERS SHALL BE OPENED AND SAME SHALL BE CONSIDERED AS INITIAL BIDS OF BIDDERS IN RA. IN CASE ANY BIDDER(S) DO (ES) NOT PARTICIPATE IN ONLINE REVERSE AUCTION, THEIR SEALED ENVELOPE PRICE BID ALONG WITH APPLICABLE LOADING, IF ANY, SHALL BE CONSIDERED FOR RANKING.</p>	
27.	<p>IF ANY OF THE VENDORS DO NOT ACCEPT THE ABOVE POINT MENTIONED AT SL. NO. 26, THEIR OFFER MAY BE LIABLE FOR REJECTION WITHOUT INTIMATION.</p>	
28.	<p>BHEL MAY SHORT CLOSE/CANCEL AN ORDER AT ANY TIME DURING THE CURRENCY OF THE CONTRACT/PO IRRESPECTIVE OF THE PO DELIVERY DATE, IF</p> <p>(I) THE WORK PROGRESS OF THE VENDOR IS POOR, OR</p> <p>(II) THE DELIVERY REQUIREMENT OF THE ITEM IS VERY CRITICAL & NOT BEING MET BY THE VENDOR ON WHICH ORDER HAS BEEN PLACED, OR</p> <p>(III) THERE IS NO RESPONSE FOR IMPROVEMENT IN DELIVERY AS PER BHEL REQUIREMENT,</p>	
29.	<p>THE OFFERS OF THE BIDDERS WHO ARE ON THE BANNED LIST AND ALSO THE OFFER OF THE BIDDERS, WHO ENGAGE THE SERVICES OF THE BANNED FIRMS, SHALL BE REJECTED. THE LIST OF BANNED FIRMS IS AVAILABLE ON BHEL WEB SITE www.bhel.com</p>	
30.	<p>RESERVATION RIGHTS OF BHEL: – BHEL RESERVES THE RIGHT TO REJECT ANY OR ALL QUOTATIONS WITHOUT ASSIGNING ANY REASONS THEREOF. BHEL ALSO RESERVES THE RIGHT TO INCREASE OR DECREASE THE TENDERED QUANTITIES. VENDORS SHOULD BE PREPARED TO ACCEPT ORDER FOR REDUCED QUANTITIES WITHOUT ANY EXTRA CHARGES. VENDOR SHOULD ALSO BE PREPARED FOR GIVING DISCOUNT IN CASE OF INCREASE IN QUANTITY.</p>	
31.	<p>NON-DISCLOSURE AGREEMENT: ALL DRAWINGS AND STANDARDS ARE PROPRIETARY OF BHEL. IT MUST NOT BE USED IN ANY WAY DETRIMENTAL TO THE INTEREST OF THE COMPANY. ALL SUPPLIERS SHALL FURNISH NDAS (NON-DISCLOSURE AGREEMENT) AGAINST USE OF DOCUMENTS FURNISHED BY BHEL TOWARDS UN-AUTHORIZED USE EXCEPT FOR THE PURPOSE IT HAS BEEN FURNISHED.</p>	
32.	<p>SETTLEMENT OF DISPUTE:</p> <p>IF ANY DISPUTE OR DIFFERENCE OF ANY KIND WHATSOEVER SHALL ARISE BETWEEN BHEL AND THE SUPPLIER/VENDOR, ARISING OUT OF THE CONTRACT FOR THE PERFORMANCE OF THE WORK WHETHER DURING THE PROGRESS OF CONTRACT TERMINATION, ABANDONMENT OR BREACH OF THE CONTRACT, IT SHALL IN THE FIRST PLACE REFERRED TO DESIGNATED ENGINEER FOR AMICABLE RESOLUTION BY THE PARTIES. DESIGNATED ENGINEER (TO BE NOMINATED BY BHEL FOR SETTLEMENT OF DISPUTES ARISING OUT OF THE CONTRACT) WHO WITHIN 60 DAYS AFTER BEING REQUESTED SHALL GIVE WRITTEN NOTICE OF HIS DECISION TO THE CONTRACTOR. SAVE AS HEREINAFTER PROVIDED, SUCH DECISION IN RESPECT OF EVERY MATTER SO REFERRED SHALL FORTHWITH BE GIVEN EFFECT TO BY THE SUPPLIER/VENDOR WHO SHALL PROCEED WITH THE WORK WITH ALL DUE DILIGENCE, WHETHER HE OR BHEL DESIRES TO RESOLVE THE DISPUTE AS HEREINAFTER PROVIDED OR NOT.</p> <p>IF AFTER THE DESIGNATED ENGINEER HAS GIVEN WRITTEN NOTICE OF THIS DECISION TO THE PARTY AND NO INTENTION TO PURSUE THE DISPUTE HAS BEEN COMMUNICATED TO HIM BY THE AFFECTED PARTY WITHIN 30 DAYS FROM THE RECEIPT OF SUCH NOTICE, THE SAID DECISION SHALL BECOME FINAL AND BINDING ON THE PARTIES. IN THE EVENT THE SUPPLIER/VENDOR BEING DISSATISFIED WITH ANY SUCH DECISION OR IF AMICABLE SETTLEMENT CANNOT BE REACHED THEN ALL SUCH DISPUTED ISSUES SHALL BE RESOLVED THROUGH CONCILIATION IN TERMS OF THE BHEL CONCILIATION SCHEME 2018 AS PER CLAUSE 14.1</p>	
33.	<p>CONCILIATION (Clause 14.1):</p> <p>ANY DISPUTE, DIFFERENCE OR CONTROVERSY OF WHATEVER NATURE HOWSOEVER ARISING UNDER OR OUT OF OR IN RELATION TO THIS AGREEMENT (INCLUDING ITS INTERPRETATION) BETWEEN THE PARTIES, AND SO NOTIFIED IN WRITING BY EITHER PARTY TO THE OTHER PARTY (THE "DISPUTE") SHALL, IN THE FIRST INSTANCE, BE ATTEMPTED TO BE RESOLVED AMICABLY IN ACCORDANCE WITH THE CONCILIATION PROCEDURE AS PER BHEL CONCILIATION SCHEME 2018. THE PROCEEDINGS OF CONCILIATION SHALL BROADLY BE GOVERNED BY PART-III OF THE ARBITRATION AND CONCILIATION ACT 1996 OR ANY STATUTORY MODIFICATION THEREOF AND AS PROVIDED IN - "PROCEDURE FOR CONDUCT OF CONCILIATION PROCEEDINGS" (AS AVAILABLE IN WWW.BHEL.COM)).</p> <p>Note:</p> <p>MINISTRY OF FINANCE HAS ISSUED OM REFERENCE NO. 1/2/24 DATED 03.06.2024 REGARDING "GUIDELINES FOR ARBITRATION AND MEDIATION IN CONTRACTS OF DOMESTIC PUBLIC PROCUREMENT. IN THE SAID OM IT HAS BEEN RECOMMENDED THAT GOVERNMENT DEPARTMENTS/ ENTITIES/AGENCIES ARE TO ENCOURAGE MEDIATION UNDER THE MEDIATION ACT. 2023. THE SAID ACT HAS NOT YET BEEN NOTIFIED BY THE GOVERNMENT. THEREFORE, THE CLAUSE "SETTLEMENT OF DISPUTES" SHALL BE MODIFIED ACCORDINGLY AS AND WHEN THE MEDIATION ACT 2023 GETS NOTIFIED.</p>	
34.	<p>ARBITRATION (14.2) :</p>	

**GENERAL COMMERCIAL TERMS & CONDITIONS OF ENQUIRY
(FOR INDIAN VENDORS)**

Amendment- 27
ANNEXURE-A

	<p>14.2.1 EXCEPT AS PROVIDED ELSEWHERE IN THIS CONTRACT, IN CASE PARTIES ARE UNABLE TO REACH AMICABLE SETTLEMENT (WHETHER BY CONCILIATION TO BE CONDUCTED AS PROVIDED IN CLAUSE 14.1 HEREIN ABOVE OR OTHERWISE) IN RESPECT OF ANY DISPUTE OR DIFFERENCE; ARISING OUT OF THE FORMATION, BREACH, TERMINATION, VALIDITY OR EXECUTION OF THE CONTRACT; OR, THE RESPECTIVE RIGHTS AND LIABILITIES OF THE PARTIES; OR, IN RELATION TO INTERPRETATION OF ANY PROVISION OF THE CONTRACT; OR, IN ANY MANNER TOUCHING UPON THE CONTRACT (HEREINAFTER REFERRED TO AS THE 'DISPUTE'), THEN, EITHER PARTY MAY, REFER THE DISPUTES TO ARBITRAL INSTITUTION (TO BE IDENTIFIED BY BHEL VARANASI) AND SUCH DISPUTE TO BE ADJUDICATED BY SOLE ARBITRATOR APPOINTED IN ACCORDANCE WITH THE RULES OF SAID ARBITRAL INSTITUTION.</p> <p>14.2.2 A PARTY WILLING TO COMMENCE ARBITRATION PROCEEDING SHALL INVOKE ARBITRATION CLAUSE BY GIVING NOTICE TO THE OTHER PARTY IN TERMS OF SECTION 21 OF THE ARBITRATION & CONCILIATION ACT, 1996 (HEREINAFTER REFERRED TO AS THE 'NOTICE') BEFORE REFERRING THE MATTER TO ARBITRAL INSTITUTION. THE NOTICE SHALL BE ADDRESSED TO THE HEAD OF THE UNIT, BHEL, EXECUTING THE CONTRACT AND SHALL CONTAIN THE PARTICULARS OF ALL CLAIMS TO BE REFERRED TO ARBITRATION WITH SUFFICIENT DETAIL AND SHALL ALSO INDICATE THE MONETARY AMOUNT OF SUCH CLAIM INCLUDING INTEREST, IF ANY.</p> <p>14.2.3 AFTER EXPIRY OF 30 DAYS FROM THE DATE OF RECEIPT OF AFORESAID NOTICE, THE PARTY INVOKING THE ARBITRATION SHALL SUBMIT THAT DISPUTE TO THE ARBITRAL INSTITUTIONS (TO BE IDENTIFIED BY BHEL VARANASI)AND THAT DISPUTE SHALL BE ADJUDICATED IN ACCORDANCE WITH THEIR RESPECTIVE ARBITRATION RULES. THE MATTER SHALL BE ADJUDICATED BY A SOLE ARBITRATOR WHO SHALL NECESSARILY BE A RETD JUDGE HAVING CONSIDERABLE EXPERIENCE IN COMMERCIAL MATTERS TO BE APPOINTED/NOMINATED BY THE RESPECTIVE INSTITUTION. THE COST/EXPENSES PERTAINING TO THE SAID ARBITRATION SHALL ALSO BE GOVERNED IN ACCORDANCE WITH THE RULES OF THE RESPECTIVE ARBITRAL INSTITUTION. THE DECISION OF THE PARTY INVOKING THE ARBITRATION FOR REFERENCE OF DISPUTE TO A SPECIFIC ARBITRAL INSTITUTION FOR ADJUDICATION OF THAT DISPUTE SHALL BE FINAL AND BINDING ON BOTH THE PARTIES AND SHALL NOT BE SUBJECT TO ANY CHANGE THEREAFTER. THE INSTITUTION ONCE SELECTED AT THE TIME OF INVOCATION OF DISPUTE SHALL REMAIN UNCHANGED.</p> <p>14.2.4 THE FEE AND EXPENSES SHALL BE BORNE BY THE PARTIES AS PER THE ARBITRAL INSTITUTIONAL RULES.</p> <p>14.2.5 THE ARBITRATION PROCEEDINGS SHALL BE IN ENGLISH LANGUAGE AND THE SEAT AND VENUE OF ARBITRATION SHALL BE AT Varanasi (U.P.).</p> <p>14.2.6 SUBJECT TO THE ABOVE, THE PROVISIONS OF ARBITRATION & CONCILIATION ACT 1996 AND ANY AMENDMENT THEREOF SHALL BE APPLICABLE. ALL MATTERS RELATING TO THIS CONTRACT AND ARISING OUT OF INVOCATION OF ARBITRATION CLAUSE ARE SUBJECT TO THE EXCLUSIVE JURISDICTION OF THE COURT(S) SITUATED AT Varanasi (U.P.).</p> <p>14.2.7 NOTWITHSTANDING ANY REFERENCE TO THE DESIGNATED ENGINEER OR CONCILIATION OR ARBITRATION HEREIN, A. THE PARTIES SHALL CONTINUE TO PERFORM THEIR RESPECTIVE OBLIGATIONS UNDER THE CONTRACT UNLESS THEY OTHERWISE AGREE. SETTLEMENT OF DISPUTE CLAUSE CANNOT BE INVOKED BY THE CONTRACTOR, IF THE CONTRACT HAS BEEN MUTUALLY CLOSED OR 'NO DEMAND CERTIFICATE' HAS BEEN FURNISHED BY THE CONTRACTOR OR ANY SETTLEMENT AGREEMENT HAS BEEN SIGNED BETWEEN THE EMPLOYER AND THE CONTRACTOR.</p> <p>14.2.8 IT IS AGREED THAT MECHANISM OF RESOLUTION OF DISPUTES THROUGH ARBITRATION SHALL BE AVAILABLE ONLY IN THE CASES WHERE THE VALUE OF THE DISPUTE IS LESS THAN RS. 10 CRORES.</p> <p>14.2.9 IN CASE THE DISPUTED AMOUNT CLAIM, COUNTER CLAIM INCLUDING INTEREST IS RS. 10 CRORES AND ABOVE, THE PARTIES SHALL BE WITHIN THEIR RIGHTS TO TAKE RECOURSE TO REMEDIES OTHER THAN ARBITRATION, AS MAY BE AVAILABLE TO THEM UNDER THE APPLICABLE LAWS AFTER PRIOR INTIMATION TO THE OTHER PARTY. SUBJECT TO THE AFORESAID CONDITIONS, PROVISIONS OF THE ARBITRATION AND CONCILIATION ACT, 1996 AND ANY STATUTORY MODIFICATIONS OR RE-ENACTMENT THEREOF AS AMENDED FROM TIME TO TIME, SHALL APPLY TO THE ARBITRATION PROCEEDINGS UNDER THIS CLAUSE.</p> <p>14.2.10 IN CASE, MULTIPLE ARBITRATIONS ARE INVOKED (WHETHER SUB-JUDICE OR ARBITRAL AWARD PASSED) BY ANY PARTY TO UNDER THIS CONTRACT, THEN THE CUMULATIVE VALUE OF CLAIMS (INCLUDING INTEREST CLAIMED OR AWARDED) IN ALL SUCH ARBITRATIONS SHALL BE TAKEN IN ACCOUNT WHILE ARRIVING AT THE TOTAL CLAIM IN DISPUTE FOR THE SUBJECT CONTRACT FOR THE PURPOSE OF CLAUSE 14.2.9. DISPUTES HAVING CUMULATIVE VALUE OF LESS THAN 10 CRORES SHALL BE RESOLVED THROUGH ARBITRATION AND ANY ADDITIONAL DISPUTE SHALL BE ADJUDICATED BY THE COURT OF COMPETENT JURISDICTION.</p> <p>14.2.11 IN CASE OF CONTRACT WITH PUBLIC SECTOR ENTERPRISE (PSE) OR A GOVERNMENT DEPARTMENT, THE FOLLOWING SHALL BE APPLICABLE: IN THE EVENT OF ANY DISPUTE OR DIFFERENCE RELATING TO THE INTERPRETATION AND APPLICATION OF THE PROVISIONS OF COMMERCIAL CONTRACT(S) BETWEEN CENTRAL PUBLIC SECTOR ENTERPRISES (CPSES)/ PORT TRUSTS INTER SE AND ALSO BETWEEN CPSES AND GOVERNMENT DEPARTMENTS/ORGANIZATIONS (EXCLUDING DISPUTES CONCERNING RAILWAYS, INCOME TAX, CUSTOMS & EXCISE DEPARTMENTS), SUCH DISPUTE OR DIFFERENCE SHALL BE TAKEN UP BY EITHER PARTY FOR RESOLUTION THROUGH AMRCD (ADMINISTRATIVE MECHANISM FOR RESOLUTION OF CPSES DISPUTES) AS MENTIONED IN DPE OM NO. 05/0003/2019-FTS-10937 DATED 14-12-2022 AS AMENDED FROM TIME TO TIME.</p>	
35.	<p>JURISDICTION : THIS CONTRACT SHALL BE GOVERNED BY THE LAW FOR THE TIME BEING IN FORCE IN THE REPUBLIC OF INDIA. THE CIVIL COURT HAVING ORIGINAL CIVIL JURISDICTION AT VARANASI-UP, SHALL ALONE HAVE EXCLUSIVE JURISDICTION IN REGARD TO ALL MATTERS IN RESPECT OF THE CONTRACT.</p>	
36.	<p>I. FOLLOWING DOCUMENTS SHOULD BE ENCLOSED AND ADDRESSED TO DGM (FINANCE) AND SAME SHALL BE DISPATCHED TO MM DEPTT. BHEL, HERP, TARNA, SHIVPUR, VARANASI-221003 FOR PAYMENT PURPOSE:</p> <ol style="list-style-type: none"> 05 (FIVE) COPIES OF GST INVOICES COPY OF GR/RR. TEST CERTIFICATE AND GUARANTEE/WARRANTEE CERTIFICATE AND PDI REPORT, IF APPLICABLE. (ONE COPY). <p>II. FURTHER TO ABOVE, 02 (TWO) COMPLETE SETS OF DOCUMENTS (COPIES OF ABOVE MENTIONED DOCUMENTS AT SL. NO. I FOR INDIAN SUPPLIERS (UNDER THIS CLAUSE) SHALL BE SENT FOR PURCHASE AND QUALITY DEPARTMENTS. ORIGINAL COPIES OF TC, GC, PDI REPORTS & OTHER QUALITY PAPERS SHALL BE ATTACHED IN THE SET OF DOCUMENTS FOR QUALITY DEPARTMENTS.</p> <p>III. THE VENDOR SHOULD PROVIDE BILLS & OTHER DOCUMENTS COMPLETE IN ALL RESPECT AS PER PURCHASE ORDER ALONGWITH DESPATCH OF MATERIALS. BHEL SHALL SEEK CLARIFICATION(S) (IF ANY) RELATED TO PAYMENT DOCUMENTS IN ONE GO. THE VENDOR SHOULD PROVIDE ALL SUCH CLARIFICATION(S) IMMEDIATELY.ANY DELAY IN PROCESSING OF PAYMENT, DUE TO NON RECEIPT OF CLARIFICATION(S) SOUGHT BY BHEL, SHALL BE ATTRIBUTABLE COMPLETELY TO VENDOR.</p> <p>IV. DIGITALLY SIGNED INVOICE IS ALSO ACCEPTABLE FOR PROCESSING OF PAYMENT.</p>	
37.	<p>THE VENDOR SHALL ENSURE THAT THEIR BANK DETAILS ARE UPDATED WITH US FOR TIMELY PAYMENT THROUGH EFT (ELECTRONICS FUND TRANSFER).</p>	
38.	<p>GUIDELINES FOR SUSPENSION OF BUSINESS DEALINGS WITH SUPPLIERS/ CONTRACTORS: THE REVISED GUIDELINES FOR SUSPENSION OF BUSSINESS DEALINGS ARE AVAILABLE ON BHEL WEBSITE AT "www.bhel.com" on "SUPPLIER REGISTRATION PAGE". RESPECTIVE BIDDERS / SUPPLIERS MAY REFER THIS BEFORE QUOTING AS PER THEIR REQUIREMENT. ACTION AGAINST THE DEFAULTED SUPPLIERS/ CONTRACTORS' SHALL BE TAKEN AS PER THESE GUIDELINES ONLY.</p>	
39.	<p>VENDOR MUST FOLLOW THE SEQUENTIAL DELIVERY SCHEDULE i.e. ITEMS TO BE SUPPLIED IN SUCH A MANNER THAT THE PURCHASE ORDER HAVING OLDER DELIVERY SCHEDULE SHOULD BE SUPPLIED EARLIER AND PURCHASE ORDER HAVING LATTER DELIVERY SCHEDULE TO BE SUPPLIED LATTER. IF ANY VENDOR DOES NOT FOLLOW THE SEQUENTIAL DELIVERY SCHEDULE ESPECIALLY FOR SAME ITEM, BHEL MAY ACCOUNT FOR THE ITEM IN SEQUENTIAL MANNER OR MAY RECOVER THE FINANCIAL IMPLICATION.</p>	
40.	<p>ALL ABOVE ACCEPTED TERMS & CONDITIONS SHALL BE PART OF PURCHASE ORDER WITH OR WITHOUT MENTIONING IN THE PO/CONTRACT BASED ON YOUR ACCEPTANCE AND OFFER SUBMITTED.</p>	

**GENERAL COMMERCIAL TERMS & CONDITIONS OF ENQUIRY
(FOR INDIAN VENDORS)**

Amendment- 27
ANNEXURE-A

41.	<p>IMPORTANT INSTRUCTION:</p> <p>I.VENDORS ARE REQUESTED TO QUOTE THEIR RATE WITH DESCRIPTION MENTIONED IN THE ENQUIRY CONSIDERING ALL TECHNICAL TERMS & CONDITIONS OF THE ENQUIRY. ALSO RATES QUOTED SHOULD BE EXACTLY AS PER SL. NO. OF HARD COPY OF THE ENQUIRY (IF ENQUIRY HAS BEEN FLOATED THROUGH CONVENTIONAL MODE) OR AS PER SL. NO. APPEARING IN THE e-Procurement PORTAL (IF ENQUIRY HAS BEEN FLOATED THROUGH e-Procurement) ONLY. IT MUST BE FOLLOWED UP TO AVOID CONFUSION AT LATER STAGES. ALSO RATES TO BE SUBMITTED BOTH IN NUMERICS AS WELL AS IN WORD. IN CASE OF DISCREPENCY, RATES SUBMITTED IN WORDS SHALL BE CONSIDERED FOR FURTHER PROCESSING.</p> <p>II.DOCUMENTS SUBMITTED WITH THE OFFER SHOULD BE SIGNED AND STAMPED IN EACH PAGE BY AUTHORIZED REPRESENTATIVE OF THE BIDDER.</p> <p>III.IN CASE OF PDI, VENDOR SHALL RAISE ONLINE INSPECTION CALL IN ONLINE INSPECTION PORTAL/INTIMATE BHEL IN WRITTING (WHERE INSPECTION IS IN BHEL HERP SCOPE) AT LEAST 01 WEEK IN ADVANCE OR AS MUTUALLY AGREED PERIOD ABOUT THE DATE AND PLACE AT WHICH GOODS WILL BE READY FOR INSPECTION.</p> <p>IV.PURCHASER OR HIS AUTHORIZED REPRESENTATIVE SHALL BE ENTITLED TO CARRY OUT SURVEILLANCE INSPECTION OF MATERIAL AND WORKMANSHIP AT SELLER'S PREMISES OR AT HIS SUB-CONTRACTOR'S PREMISES AT ALL REASONABLE TIMES DURING EXECUTION OF THE CONTRACT. SUCH INSPECTION, EXAMINATION AND TESTING, IF MADE, SHALL NOT ABSOLVE THE SELLER FROM HIS OBLIGATIONS UNDER THE CONTRACT.</p> <p>V.SUCH PRE-DISPATCH INSPECTION, EXAMINATION AND TESTING, IF MADE, AT VENDOR'S WORKS SHALL NOT ABSOLVE THE SELLER FROM HIS OBLIGATIONS TO MANUFACTURE/MACHINING THE GOODS UNDER THE CONTRACT. IF DEFECTS ARE FOUND AT LATER STAGE, IT IS THE SOLE RESPONSIBILITY OF THE VENDOR TO REPLACE/RECTIFY THE SAME.</p>	
42.	<p>IMPORTANT CLAUSE FOR GST: INPUT TAX CREDIT OF GST CAN BE AVAILED BY BHEL ONLY WHEN THE MATERIAL HAS BEEN PHYSICALLY RECEIVED AND GST INVOICE IS IN POSSESSION OF BHEL. THEREFORE, SUPPLIERS SHOULD ENSURE THE FOLLOWING IN RESPECT OF POS ISSUED BY BHEL:</p> <p>I. GST INVOICE SHOULD CONTAIN ADDRESS, GST NO. AND PAN NO. OF BHEL AS WELL AS OF SUPPLIER. APPLICABLE HSN CODE OF THE MATERIAL SHOULD BE INDICATED IN THE GST INVOICE.</p> <p>II. FIVE COPIES OF GST INVOICE AND LORRY RECEIPT MAY BE DESPATCHED ALONGWITH SHIPMENT OF THE GOODS IN ORDER TO AVOID ANY DELAY IN AVAILING INPUT CREDIT BY BHEL.</p> <p>III. DECLARE SUCH INVOICE IN HIS GSTR-1 RETURN FOR THE MONTH OF DESPATCH OF MATERIAL.</p> <p>IV. PAYMENT OF GST TO STATUTORY AUTHORITIES WITHIN PRESCRIBED TIME.</p> <p>V. IN CASE OF DISCREPANCY IN THE DATA UPLOADED BY THE BIDDER IN THE GSTN PORTAL VIS-A-VIS THE TAX INVOICE OR IN CASE OF ANY SHORTAGES OR REJECTION IN THE SUPPLY, THEN BHEL WILL NOT BE ABLE TO AVAIL THE TAX CREDIT. BIDDER HAS TO RECTIFY THE DATA DISCREPANCY IN THE GSTN PORTAL OR ISSUE CREDIT NOTE OR DEBIT NOTE (DETAILS ALSO TO BE UPLOADED IN GSTN PORTAL) FOR THE SHORTAGES OR REJECTIONS IN THE SUPPLIES OR ADDITIONAL CLAIMS FOR PROCESSING OF SUCH INVOICES.</p> <p>VI. GST TDS DEDUCTED AS PER GST ACT, IS UPLOADED IN GSTN PORTAL ALONG GSTR7. BIDDERS CAN DIRECTLY DOWNLOAD THE GST TDS CERTIFICATE FROM THE GSTN PORTAL.</p> <p>IN CASE GST CREDIT IS DELAYED /DENIED TO BHEL DUE TO NON OR DELAYED RECEIPT OF GOODS AND OR TAX INVOICE OR EXPIRY OF TIMELINE PRESCRIBED IN GST LAW FOR AVAILING SUCH ITC OR ANY OTHER REASON NOT ATTRIBUTABLE TO BHEL, GST AMOUNT SHALL BE RECOVERABLE FROM VENDOR ALONG WITH INTEREST /PENALTY LEVIABLE ON BHEL.</p> <p>IN CASE SUPPLIERS DELAYS DECLARING SUCH INVOICE IN HIS RETURN AND GST CREDIT AVAILED BY BHEL IS DENIED OR REVERSED SUBSEQUENTLY AS PER GST LAW, GST AMOUNT PAID BY BHEL TOWARDS SUCH ITC REVERSAL SHALL BE RECOVERABLE FROM SUPPLIER ALONGWITH INTEREST LEVIED/LEVIABLE ON BHEL.</p> <p>IN CASE OF RAISING ANY SUPPLEMENTARY TAX INVOICE (DEBIT/ CREDIT NOTE), THE SUPPLIER SHALL ISSUE THE SAME CONTAINING ALL THE DETAILS AS REFERRED TO IN SECTION 34 READ WITH SECTION 31 OF GST ACT & RULES REFERRED THERE UNDER .</p>	
43.	<p>STATUTORY VARIATION CLAUSE : ANY INCREASE IN THE RATE OF GST SHALL BE PAYABLE ONLY FOR DELIVERIES COMPLETED WITHIN THE SCHEDULED DELIVERY PERIOD, IN OTHER WORDS INCREASE IN THE RATE OF GST SHALL NOT BE PAYABLE FOR VALUE OF CONSIGNMENT DELIVERED AFTER THE SCHEDULED PURCHASE ORDER DELIVERY PERIOD.2.NEW TAXES AND DUTIES, IF IMPOSED SUBSEQUENT TO DUE DATE OF OFFER SUBMISSION, BY STATUTORY AUTHORITY DURING CONTRACT PERIOD (INCLUDING EXTENSION IF THE SAME IS NOT ATTRIBUTABLE TO BIDDER) SHALL BE REIMBURSED BY BHEL ON PRODUCTION OF RELEVANT SUPPORTING DOCUMENTS TO THE SATISFACTION OF BHEL. HOWEVER, BIDDER SHALL TAKE PRIOR APPROVAL OF BHEL BEFORE DEPOSITING NEW TAXES AND DUTIES.</p>	
44.	<p>IMPORTANT INSTRUCTION FOR MSEs SUPPLIERS:</p> <p>I. "MSE SUPPLIERS CAN AVAIL THE INTENDED BENEFITS ONLY IF THEY SUBMIT ALONG WITH OFFER, ATTESTED COPIES OF EITHER EM-II CERTIFICATE HAVING DEEMED VALIDITY (FIVE YEARS FROM THE DATE OF ISSUE OF ACKNOWLEDGEMENT IN EM-II) OR VALID NSIC CERTIFICATE OR EM-II CERTIFICATE ALONG WITH CA CERTIFICATE (FORMAT ENCLOSED AS PER ANNEXURE-1 WHERE DEEMED VALIDITY OF EM-II CERTIFICATE OF FIVE YEARS HAS EXPIRED) APPLICABLE FOR THE RELEVANT F/Y (LATEST AUDITED).DATE TO BE RECKONED FOR DETERMINING THE DEEMED VALIDITY WILL BE THE DATE OF BID OPENING (PART -1 IN CASE OF TWO PART BID). NON SUBMISSION OF SUCH DOCUMENTS WILL LEAD TO CONSIDERATION OF THEIR BID AT PAR WITH OTHER BIDDERS. NO BENEFIT SHALL BE APPLICABLE FOR THIS ENQUIRY IF ANY DEFICIENCY IN THE ABOVE REQUIRED DOCUMENTS ARE NOT SUBMITTED BEFORE PRICE BID OPENING. IF THE TENDER IS TO BE SUBMITTED THROUGH e-procurement PORTAL, THEN THE ABOVE REQUIRED DOCUMENTS ARE TO BE UPLOADED ON THE PORTAL. DOCUMENTS SHOULD BE NOTARIZED OR ATTESTED BY A GAZETTED OFFICE.</p> <p>II.IN CASE OF ANY CHANGE IN THE MSE STATUS OF THE BIDDER, IT SHALL BE RESPONSIBILITY OF THE BIDDER TO NOTIFY THE CHANGE AS A PART OF THE BID DOCUMENT. IF AT A LATER DATE IT COMES TO NOTICE OF BHEL, THAT THE CHANGE IN THE STATUS HAS NOT BEEN INTIMATED BY THE BIDDER AND THE ORDER IS OBTAINED UNDER THE PREMISE OF AN MSE, THEN BHEL WOULD CANCEL THE PENDING ORDER AGAINST THIS TENDER AND TAKE NECESSARY ACTION SUSPENSION OF THE BUSSINESS DEALING WITH THE BIDDER AS PER PROCUREMENT POLICY OF BHEL.</p> <p>III.25 % OF THE TENDERED QUANTITY IS EARMARKED FOR MSE SUPPLIERS IN THIS TENDER.</p> <p>IV.OUT OF THIS 25% TENDERED QUANTITY RESERVED FOR MSE SUPPLIERS, 4 % SHALL BE EARMARKED FOR PROCUREMENT FROM MSEs OWNED BY SC/ST ENTREPRENEURS.</p> <p>V.OUT OF THIS 25% TENDERED QUANTITY RESERVED FOR MSE SUPPLIERS, 3% SHALL BE EARMARKED FOR PROCUREMENT FROM MSEs OWNED BY WOMEN.</p> <p>VI.IN CASE MSE VENDOR PARTICIPATING IN THE TENDER QUOTES WITHIN THE PRICE BAND OF "L1+15%", THEY WILL BE ALLOWED TO SUPPLY THE 25% PORTION OF THE REQUIREMENT SUBJECT TO ACCEPTANCE OF L1 PRICE (ON LANDED COST BASIS) BY MSE VENDOR. IN CASE OF MORE THAN ONE SUCH MSE VENDOR WITHIN THE "L1+15% PRICE BAND" THE SUPPLY SHALL BE SHARED PROPORTIONATELY (TO 25% TENDERED QUANTITY).</p> <p>VII.IF THE L1 VENDOR HAPPENS TO BE A MSE VENDOR AGAINST ANY ITEM CODE, THEN 100% OF THE TENDERED QTY (FOR RESPECTIVE ITEM CODE) SHALL BE PROPOSED TO ORDER ON THE L1 (MSE) VENDOR, EVEN THOUGH THERE MAY BE OTHER MSE VENDORS WITHIN THE "L1+15% PRICE BAND".</p> <p>VIII.IN CASE AFTER OPENING OF PRICE BID, IT IS SEEN THAT NO MSE HAS BECOME L1, THEN DEPENDING ON THE NATURE OF THE ITEM, IF IT IS NOT POSSIBLE TO SPLIT THE TENDERED ITEMS/QUANTITIES ON ACCOUNT OF REASONS LIKE CUSTOMER CONTRACT REQUIREMENTS OF SUPPLYING ONE MAKE FOR A GIVEN PROJECT OR TECHNICAL REASONS LIKE TENDERED ITEMS BEING A SYSTEM etc. THEN BHEL WOULD NOT COUNTER OFFER THE L1 PRICES EVEN THOUGH THERE MAY BE MSE BIDDERS WITHIN THE "L1+15% PRICE BAND" OF L1.</p>	
45.	<p>THE STARTUPS AS DEFINED IN THE GAZETTE OF INDIA NOTIFICATION NO.: G.S.R. 127 (E) DATED 19/02/2019 WILL BE EXEMPTED FROM FULFILLING THE CRITERIA, IF MENTIONED, IN THE PQR (PRE-QUALIFYING REQUIREMENT) REGARDING PRIOR TURNOVER AND PRIOR EXPERIENCE. HOWEVER, THERE MAY BE CIRCUMSTANCES (LIKE PROCUREMENTS OF ITEMS RELATED TO PUBLIC SAFETY, HEALTH, CRITICAL SECURITY OPERATIONS AND EQUIPMENTS ETC.) WHERE BHEL MAY PREFER THE VENDORS TO HAVE PRIOR EXPERIENCE RATHER THAN GIVING ORDER TO NEW ENTITIES. FOR SUCH PROCUREMENTS, BHEL MAY NOT RELAX THE CRITERIA OF PRIOR EXPERIENCE/TURNOVER FOR THE STARTUPS.</p>	
46.	<p>PURCHASE PREFERENCE FOR INDIAN VENDORS: FOR THIS PROCUREMENT, THE LOCAL CONTENT TO CATEGORIZE A SUPPLIER AS A CLASS I LOCAL SUPPLIER / CLASS II LOCAL SUPPLIER /NON LOCAL – SUPPLIER AND PURCHASE PREFERENCE TO CLASS I LOCAL SUPPLIER, IS AS DEFINED IN PUBLIC PROCUREMENT (PREFERNCE TO MAKE IN INDIA), ORDER 2017 DATED 04.06.2020 ISSUED BY DPIIT. IN CASE OF SUBSEQUENT ORDERS ISSUED BY THE NODAL MINISTRY, CHANGING THE DEFINITION OF LOCAL CONTENT FOR THE ITEMS OF THE NIT, THE SAME SHALL BE APPLICABLE EVEN IF ISSUED AFTER ISSUE OF THIS NIT, BUT BEFORE OPENING OF PART –II BIDS AGAINST THIS NIT.</p> <p>MODEL CLAUSE FOR TENDER.</p> <p>I. ANY BIDDER FROM A COUNTRY WHICH SHARES A LAND BORDER WITH INDIA WILL BE ELIGIBLE TO BID IN THIS TENDER ONLY IF THE BIDDER IS REGISTERED WITH THE COMPETENT AUTHORITY.</p>	

**GENERAL COMMERCIAL TERMS & CONDITIONS OF ENQUIRY
(FOR INDIAN VENDORS)**

Amendment- 27

ANNEXURE-A

	<p>II. "BIDDER" (INCLUDING THE TERM 'TENDERER', 'CONSULTANT' OR 'SERVICE PROVIDER' IN CERTAIN CONTEXTS) MEANS ANY PERSON OR FIRM OR COMPANY, INCLUDING ANY MEMBER OF A CONSORTIUM OR JOINT VENTURE (THAT IS AN ASSOCIATION OF SEVERAL PERSONS, OR FIRMS OR COMPANIES), EVERY ARTIFICIAL JURIDICAL PERSON NOT FALLING IN ANY OF THE DESCRIPTIONS OF BIDDERS STATED HEREINBEFORE, INCLUDING ANY AGENCY BRANCH OR OFFICE CONTROLLED BY SUCH PERSON, PARTICIPATING IN A PROCUREMENT PROCESS.</p> <p>III. "BIDDER FROM A COUNTRY WHICH SHARES A LAND BORDER WITH INDIA" FOR THE PURPOSE OF THIS ORDER MEANS: -</p> <p>a) AN ENTITY INCORPORATED, ESTABLISHED OR REGISTERED IN SUCH A COUNTRY; OR</p> <p>b) A SUBSIDIARY OF AN ENTITY INCORPORATED, ESTABLISHED OR REGISTERED IN SUCH A COUNTRY; OR</p> <p>c) AN ENTITY SUBSTANTIALLY CONTROLLED THROUGH ENTITIES INCORPORATED, ESTABLISHED OR REGISTERED IN SUCH A COUNTRY; OR</p> <p>d) AN ENTITY WHOSE BENEFICIAL OWNER IS SITUATED IN SUCH A COUNTRY; OR</p> <p>e) AN INDIAN (OR OTHER) AGENT OF SUCH AN ENTITY; OR</p> <p>f) A NATURAL PERSON WHO IS A CITIZEN OF SUCH A COUNTRY; OR</p> <p>g) A CONSORTIUM OR JOINT VENTURE WHERE ANY MEMBER OF THE CONSORTIUM OR JOINT VENTURE FALLS UNDER ANY OF THE ABOVE</p> <p>IV. THE BENEFICIAL OWNER FOR THE PURPOSE OF (III) ABOVE WILL BE AS UNDER:</p> <p>1. IN CASE OF A COMPANY OR LIMITED LIABILITY PARTNERSHIP, THE BENEFICIAL OWNER IS THE NATURAL PERSON (S) WHO, WHETHER ACTING ALONE OR TOGETHER, OR THROUGH ONE OR MORE JURIDICAL PERSON, HAS A CONTROLLING OWNERSHIP INTEREST OR WHO EXERCISES CONTROL THROUGH OTHER MEANS.</p> <p>EXPLANATION –</p> <p>a. "CONTROLLING OWNERSHIP INTEREST" MEANS OWNERSHIP OF OR ENTITLEMENT TO MORE THAN TWENTY-FIVE PER CENT. OF SHARES OR CAPITAL OR PROFITS OF THE COMPANY</p> <p>b. "CONTROL" SHALL INCLUDE THE RIGHT TO APPOINT MAJORITY OF THE DIRECTORS OR TO CONTROL THE MANAGEMENT OR POLICY DECISIONS INCLUDING BY VIRTUE OF THEIR SHAREHOLDING OR MANAGEMENT RIGHTS OR SHAREHOLDER'S AGREEMENTS OF VOTING AGREEMENTS;</p> <p>2. IN CASE OF A PARTNERSHIP FIRM, THE BENEFICIAL OWNER IS THE NATURAL PERSON (S) WHO, WHETHER ACTING ALONE OR TOGETHER, OR THROUGH ONE OR MORE JURIDICAL OF CAPITAL OR PROFITS OF THE PARTNERSHIP;</p> <p>3. IN CASE OF AN UNINCORPORATED ASSOCIATION OR BODY OF INDIVIDUALS, THE BENEFICIAL OWNER IS THE NATURAL PERSON (S), WHO, WHETHER ACTING ALONE OR TOGETHER, OR THROUGH ONE OR MORE JURIDICAL PERSON, HAS OWNERSHIP OF OR ENTITLEMENT TO MORE THAN FIFTEEN PERCENT OF THE PROPERTY OF CAPITAL OF PROFITS OF SUCH ASSOCIATION OR BODY OF INDIVIDUALS;</p> <p>4. WHERE NO NATURAL PERSON IS IDENTIFIED UNDER (1) OR (2) OR (3) ABOVE, THE BENEFICIAL OWNER IS THE RELEVANT NATURAL PERSON WHO HOLDS THE POSITION OF SENIOR MANAGING OFFICIAL;</p> <p>5. IN CASE OF TRUST, THE IDENTIFICATION OF BENEFICIAL OWNER (S) SHALL INCLUDE IDENTIFICATION OF THE AUTHOR OF THE TRUST, THE TRUSTEE, THE BENEFICIARIES WITH FIFTEEN PERCENT OR MORE INTEREST IN THE TRUST AND ANY OTHER NATURAL PERSON EXERCISING ULTIMATE EFFECTIVE CONTROL OVER THE TRUST THROUGH A CHAIN OF CONTROL OR OWNERSHIP.</p> <p>V. AN AGENT IS A PERSON EMPLOYED TO DO ANY ACT FOR ANOTHER, OR TO REPRESENT ANOTHER IN DEALINGS WITH THIRD PERSON.</p> <p>CERTIFICATE: IN ORDER TO AVAIL THE BENEFITS, VENDORS TO SUBMIT (ALONG WITH OFFER) THE SELF-CERTIFICATION THAT THE ITEM OFFERED MEETS THE CONTENT REQUIREMENT FOR CLASS-I/ CLASS-II LOCAL SUPPLIER AS THE CASE MAY BE, INDICATING THE PERCENTAGE OF LOCAL CONTENT . AND SHALL GIVE DETAILS OF LOCATION AT WHICH THE LOCAL VALUE ADDITION IS MADE (refer attached Make in India (Model Certificate no I).</p>	
47.	<p>13.1 "FORCE MAJEURE" SHALL MEAN CIRCUMSTANCE WHICH IS:</p> <p>A) BEYOND CONTROL OF EITHER OF THE PARTIES TO CONTRACT,</p> <p>B) EITHER OF THE PARTIES COULD NOT REASONABLY HAVE PROVIDED AGAINST THE EVENT BEFORE ENTERING INTO THE CONTRACT,</p> <p>C) HAVING ARISEN, EITHER OF THE PARTIES COULD NOT REASONABLY HAVE AVOIDED OR OVERCOME, AND</p> <p>D) IS NOT SUBSTANTIALLY ATTRIBUTABLE TO EITHER OF THE PARTIES</p> <p>AND</p> <p>PREVENTS THE PERFORMANCE OF THE CONTRACT</p> <p>SUCH CIRCUMSTANCES INCLUDE BUT SHALL NOT BE LIMITED TO:</p> <p>I) WAR, HOSTILITIES, INVASION, ACT OF FOREIGN ENEMIES.</p> <p>II) REBELLION, TERRORISM, REVOLUTION, INSURRECTION, MILITARY OR USURPED POWER, OR CIVIL WAR.</p> <p>III) RIOT, COMMOTION OR DISORDER BY PERSONS OTHER THAN THE CONTRACTOR'S PERSONNEL AND OTHER EMPLOYEES OF THE CONTRACTOR AND SUB-CONTRACTORS.</p> <p>IV) STRIKE OR LOCKOUT NOT SOLELY INVOLVING THE CONTRACTOR'S PERSONNEL AND OTHER EMPLOYEES OF THE CONTRACTOR AND SUB-CONTRACTORS.</p> <p>V) ENCOUNTERING MUNITIONS OF WAR, EXPLOSIVE MATERIALS, IONIZING RADIATION OR CONTAMINATION BY RADIO-ACTIVITY, EXCEPT AS MAY BE ATTRIBUTABLE TO THE CONTRACTOR'S USE OF SUCH MUNITIONS, EXPLOSIVES, RADIATION OR RADIO- ACTIVITY.</p> <p>VI) NATURAL CATASTROPHES SUCH AS EARTHQUAKE, TSUNAMI, VOLCANIC ACTIVITY, HURRICANE OR TYPHOON, FLOOD, FIRE, CYCLONES ETC.</p> <p>VII) EPIDEMIC, PANDEMIC ETC</p> <p>13.2 THE FOLLOWING EVENTS ARE EXPLICITLY EXCLUDED FROM FORCE MAJEURE AND ARE SOLELY THE RESPONSIBILITIES OF THE NON-PERFORMING PARTY: A) ANY STRIKE, WORK-TO-RULE ACTION, GO-SLOW OR SIMILAR LABOUR DIFFICULTY (B) LATE DELIVERY OF EQUIPMENT OR MATERIAL (UNLESS CAUSED BY FORCE MAJEURE EVENT) AND (C) ECONOMIC HARDSHIP.</p> <p>13.3 IF EITHER PARTY IS PREVENTED, HINDERED OR DELAYED FROM OR IN PERFORMING ANY OF ITS OBLIGATIONS UNDER THE CONTRACT BY AN EVENT OF FORCE MAJEURE, THEN IT SHALL NOTIFY THE OTHER IN WRITING OF THE OCCURRENCE OF SUCH EVENT AND THE CIRCUMSTANCES THEREOF WITHIN 15 (FIFTEEN) DAYS AFTER THE OCCURRENCE OF SUCH EVENT.</p> <p>13.4 THE PARTY WHO HAS GIVEN SUCH NOTICE SHALL BE EXCUSED FROM THE PERFORMANCE OR PUNCTUAL PERFORMANCE OF ITS OBLIGATIONS UNDER THE CONTRACT FOR SO LONG AS THE RELEVANT EVENT OF FORCE MAJEURE CONTINUES AND TO THE EXTENT THAT SUCH PARTY'S PERFORMANCE IS PREVENTED, HINDERED OR DELAYED. THE TIME FOR COMPLETION SHALL BE EXTENDED BY A PERIOD OF TIME EQUAL TO PERIOD OF DELAY CAUSED DUE TO SUCH FORCE MAJEURE EVENT.</p> <p>13.5 DELAY OR NON-PERFORMANCE BY EITHER PARTY HERETO CAUSED BY THE OCCURRENCE OF ANY EVENT OF FORCE MAJEURE SHALL NOT</p> <p>I) CONSTITUTE A DEFAULT OR BREACH OF THE CONTRACT.</p> <p>II) GIVE RISE TO ANY CLAIM FOR DAMAGES OR ADDITIONAL COST EXPENSE OCCASIONED THEREBY, IF AND TO THE EXTENT THAT SUCH DELAY OR NON-PERFORMANCE IS CAUSED BY THE OCCURRENCE OF AN EVENT OF FORCE MAJEURE.</p> <p>13.6 BHEL AT ITS DISCRETION MAY CONSIDER SHORT CLOSURE OF CONTRACT AFTER 1 YEAR OF IMPOSITION OF FORCE MAJEURE IN LINE WITH EXTANT GUIDELINES. IN ANY CASE, SUPPLIER/VENDOR CANNOT CONSIDER DEEMED SHORT-CLOSURE AFTER 1 YEAR OF IMPOSITION OF FORCE MAJEURE.</p>	
48.	<p>FRAUD PREVENTION POLICY : THE BIDDER ALONG WITH ITS ASSOCIATE/ COLLABORATORS/ SUB-CONTRACTORS/ SUB-VENDORS/ CONSULTANTS/ SERVICE PROVIDERS SHALL STRICTLY ADHERE TO BHEL FRAUD PREVENTION POLICY DISPLAYED ON BHEL WEBSITE WWW.BHEL.COM AND SHALL IMMEDIATELY BRING TO THE NOTICE OF BHEL MANAGEMENT ABOUT ANY FRAUD OR SUSPECTED FRAUD AS SOON AS IT COMES TO THEIR NOTICE.</p>	
49.	<p>SHORT SHIPMENTS/ WARRANTY/GUARANTEE REPLACEMENTS: IN CASE OF ANY SHORT SHIPMENT DURING INITIAL SUPPLY WHICH IS SUBSEQUENTLY DISPATCHED BY THE VENDOR OR ANY GUARANTEE /WARRANTY REPLACEMENTS SHALL BE DISPATCHED ON "FOR-BHEL STORES/DESIGNATED DESTINATION" BASIS FOR INDIGENOUS</p>	

**GENERAL COMMERCIAL TERMS & CONDITIONS OF ENQUIRY
(FOR INDIAN VENDORS)**

Amendment- 27
ANNEXURE-A

	ITEMS. TAXES, IF ANY PAID BY INDIGENOUS VENDOR FOR GUARANTEE /WARRANTEE REPLACEMENT, REPAIR ACTIVITY EXCLUDING SHORT SUPPLY SHALL BE TO VENDOR'S ACCOUNT ONLY. THE VENDOR HAS TO RAISE A CREDIT NOTE FOR SHORT SUPPLIED QUANTITY AS PER GST PROVISIONS.	
50.	E WAY BILL: THE SUPPLIER HAS TO ARRANGE FOR E WAY BILL AS APPLICABLE FOR ANY MOVEMENT OF GOODS ALONG WITH OTHER PRESCRIBED DOCUMENTS AS PER GST LAW. THE SUPPLIER HAS ALSO TO COMPLY WITH ANY AMENDMENT AS PRESCRIBED FROM TIME TO TIME UNDER E WAY BILL RULE. ANY FINANCIAL IMPLICATION ARISES ON BHEL DUE TO NONCOMPLIANCE OF E WAY BILL RULE WILL BE PASSED ON TO THE SUPPLIER.	
51.	THE BIDDER DECLARES THAT THEY WILL NOT ENTER INTO ANY ILLEGAL OR UNDISCLOSED AGREEMENT OR UNDERSTANDING, WHETHER FORMAL OR INFORMAL WITH OTHER BIDDER (S). THIS APPLIES IN PARTICULAR TO PRICES, SPECIFICATIONS, CERTIFICATIONS, SUBSIDIARY CONTRACTS, SUBMISSION OR NON- SUBMISSION OF BIDS OR ANY OTHER ACTIONS TO RESTRICT COMPETITIVENES OR TO INTRODUCE CARTELIZATION IN THE BIDDING PROCESS. IN CASE, THE BIDDER IS FOUND HAVING INDULGED IN ABOVE ACTIVITIES, SUITABLE ACTION SHALL BE TAKEN BY BHEL AS PER EXTANT POLICIES / GUIDELINES.	
52.	THE BIDDER SHALL REGISTER THEMSELVES ON GEM PORTAL AND SHALL QUOTE THEIR GEM SELLER ID IN THEIR OFFER. GEM SELLER ID IS MANDATORY FOR PLACEMENT OF PURCHASE ORDER EXCEPT IN CASES WHERE FREE ISSUE MATERIAL IS TO BE ISSUED BY BHEL .	
53.	REJECTION/REPLACEMENT: THE SELLER SHALL ARRANGE REPLACEMENT / REPAIR UNDER ITS OBLIGATION UNDER THE CONTRACT. SELLER SHALL BE GIVEN GROUND RENT FREE PERIOD OF 90 DAYS FROM THE DATE OF REJECTION TO LIFT REJECTED MATERIAL. BEYOND 90 DAYS, A GROUND RENT OF 0.25% OF VALUE OF REJECTED MATERIAL PER WEEK WILL BE LEVIED FOR A MAXIMUM PERIOD OF 4 WEEKS. BEYOND THIS PERIOD SUPPLIER FORFEITS THEIR RIGHT TO THE MATERIALS.	
54.	TREATMENT OF CASES REGARDING CONFLICT OF INTEREST: THE BIDDER NOTES THAT A CONFLICT OF INTEREST WOULD SAID TO HAVE OCCURRED IN THE TENDER PROCESS AND EXECUTION OF THE RESULTANT CONTRACT, IN CASE OF ANY OF THE FOLLOWING SITUATIONS: I) IF ITS PERSONNEL HAVE A CLOSE PERSONAL, FINANCIAL, OR BUSINESS RELATIONSHIP WITH ANY PERSONNEL OF BHEL WHO ARE DIRECTLY OR INDIRECTLY RELATED TO THE PROCUREMENT OR EXECUTION PROCESS OF THE CONTRACT, WHICH CAN AFFECT THE DECISION OF BHEL DIRECTLY OR INDIRECTLY; II) THE BIDDER (OR HIS ALLIED FIRM) PROVIDED SERVICES FOR THE NEED ASSESSMENT/ PROCUREMENT PLANNING OF THE TENDER PROCESS IN WHICH IT IS PARTICIPATING; III) PROCUREMENT OF GOODS DIRECTLY FROM THE MANUFACTURERS/ SUPPLIERS SHALL BE PREFERRED. HOWEVER, IF THE OEM/ PRINCIPAL INSISTS ON ENGAGING THE SERVICES OF AN AGENT, SUCH AGENT SHALL NOT BE ALLOWED TO REPRESENT MORE THAN ONE MANUFACTURER/ SUPPLIER IN THE SAME TENDER. MOREOVER, EITHER THE AGENT COULD BID ON BEHALF OF THE MANUFACTURER/ SUPPLIER OR THE MANUFACTURER/ SUPPLIER COULD BID DIRECTLY BUT NOT BOTH. IN CASE BIDS ARE RECEIVED FROM BOTH THE MANUFACTURER/ SUPPLIER AND THE AGENT, BID RECEIVED FROM THE AGENT SHALL BE IGNORED. HOWEVER, THIS SHALL NOT DEBAR MORE THAN ONE AUTHORISED DISTRIBUTOR (WITH/ OR WITHOUT THE OEM) FROM QUOTING EQUIPMENT MANUFACTURED BY AN ORIGINAL EQUIPMENT MANUFACTURER (OEM) IN PROCUREMENTS UNDER A PROPRIETARY ARTICLE CERTIFICATE. IV) A BIDDER PARTICIPATES IN MORE THAN ONE BID IN THIS TENDER PROCESS. PARTICIPATION IN ANY CAPACITY BY A BIDDER (INCLUDING THE PARTICIPATION OF A BIDDER AS A PARTNER/ JV MEMBER OR SUB-CONTRACTOR IN ANOTHER BID OR VICE-VERSA) IN MORE THAN ONE BID SHALL RESULT IN THE DISQUALIFICATION OF ALL BIDS IN WHICH HE IS A PARTY. HOWEVER, THIS DOES NOT LIMIT THE PARTICIPATION OF AN ENTITY AS A SUB-CONTRACTOR IN MORE THAN ONE BID IF HE IS NOT BIDDING INDEPENDENTLY IN HIS OWN NAME OR AS A MEMBER OF A JV. THE BIDDER DECLARES THAT THEY HAVE READ AND UNDERSTOOD THE ABOVE ASPECTS, AND THE BIDDER CONFIRMS THAT SUCH CONFLICT OF INTEREST DOES NOT EXIST AND UNDERTAKES THAT THEY WILL NOT ENTER INTO ANY ILLEGAL OR UNDISCLOSED AGREEMENT OR UNDERSTANDING, WHETHER FORMAL OR INFORMAL WITH OTHER BIDDER(S), IN THIS REGARD. THIS APPLIES IN PARTICULAR TO PRICES, SPECIFICATIONS, CERTIFICATIONS, SUBSIDIARY CONTRACTS, SUBMISSION OR NON-SUBMISSION OF BIDS OR ANY OTHER ACTIONS TO RESTRICT COMPETITIVENESS OR TO INTRODUCE CARTELIZATION IN THE BIDDING PROCESS. IN CASE, THE BIDDER IS FOUND HAVING INDULGED IN ABOVE ACTIVITIES, THE SAME WILL BE CONSIDERED AS A VIOLATION OF THE TENDER CONDITIONS, AND SUITABLE ACTION SHALL BE TAKEN BY BHEL AS PER EXTANT POLICIES/ GUIDELINES.	
55.	VENDOR MUST VISIT OUR WEBSITE https://herp.bhel.com REGULARLY FOR ENQUIRY/PO/CLARIFICATIONS/FOR ANY LATEST UPDATES.	
56.	MSME VENDORS CAN AVAIL BENEFITS OF PAYMENT THROUGH TREDS.	
57.	"THE OFFERS OF THE BIDDERS WHO ARE UNDER SUSPENSION AS ALSO THE OFFERS OF THE BIDDERS, WHO ENGAGE THE SERVICES OF THE FIRMS DEBARRED ACROSS BHEL, SHALL BE REJECTED. THE LIST OF FIRMS DEBARRED ACROSS BHEL IS AVAILABLE ON BHEL WEBSITE WWW.BHEL.COM. 1.0 INTEGRITY COMMITMENT, PERFORMANCE OF THE CONTRACT AND PUNITIVE ACTION THEREOF: 1.1. COMMITMENT BY BHEL: BHEL COMMITS TO TAKE ALL MEASURES NECESSARY TO PREVENT CORRUPTION IN CONNECTION WITH THE TENDER PROCESS AND EXECUTION OF THE CONTRACT. BHEL WILL DURING THE TENDER PROCESS TREAT ALL BIDDER(S) IN A TRANSPARENT AND FAIR MANNER, AND WITH EQUITY. 1.2. COMMITMENT BY BIDDER/ SUPPLIER/ CONTRACTOR: 1.2.1. THE BIDDER/ SUPPLIER/ CONTRACTOR COMMIT TO TAKE ALL MEASURES TO PREVENT CORRUPTION AND WILL NOT DIRECTLY OR INDIRECTLY INFLUENCE ANY DECISION OR BENEFIT WHICH HE IS NOT LEGALLY ENTITLED TO NOR WILL ACT OR OMIT IN ANY MANNER WHICH TANTAMOUNT TO AN OFFENCE PUNISHABLE UNDER ANY PROVISION OF THE INDIAN PENAL CODE, 1860 OR ANY OTHER LAW IN FORCE IN INDIA. 1.2.2. THE BIDDER/ SUPPLIER/ CONTRACTOR WILL, WHEN PRESENTING HIS BID, DISCLOSE ANY AND ALL PAYMENTS HE HAS MADE, AND IS COMMITTED TO OR INTENDS TO MAKE TO AGENTS, BROKERS OR ANY OTHER INTERMEDIARIES IN CONNECTION WITH THE AWARD OF THE CONTRACT AND SHALL ADHERE TO RELEVANT GUIDELINES ISSUED FROM TIME TO TIME BY GOVT. OF INDIA/ BHEL. 1.2.3. THE BIDDER/ SUPPLIER/ CONTRACTOR WILL PERFORM/ EXECUTE THE CONTRACT AS PER THE CONTRACT TERMS & CONDITIONS AND WILL NOT DEFAULT WITHOUT ANY REASONABLE CAUSE, WHICH CAUSES LOSS OF BUSINESS/ MONEY/ REPUTATION, TO BHEL. IF ANY BIDDER/ SUPPLIER/ CONTRACTOR DURING PRE-TENDERING/ TENDERING/ POST TENDERING/ AWARD/ EXECUTION/ POST-EXECUTION STAGE INDULGES IN MALPRACTICES, CHEATING, BRIBERY, FRAUD OR AND OTHER MISCONDUCT OR FORMATION OF CARTEL SO AS TO INFLUENCE THE BIDDING PROCESS OR INFLUENCE THE PRICE OR ACTS OR OMTS IN ANY MANNER WHICH TANTAMOUNT TO AN OFFENCE PUNISHABLE UNDER ANY PROVISION OF THE INDIAN PENAL CODE, 1860 OR ANY OTHER LAW IN FORCE IN INDIA, THEN, ACTION MAY BE TAKEN AGAINST SUCH BIDDER/ SUPPLIER/ CONTRACTOR AS PER EXTANT GUIDELINES OF THE COMPANY AVAILABLE ON WWW. BHEL.COM AND/OR UNDER APPLICABLE LEGAL PROVISIONS".	
58.	BID SECURITY OR EARNEST MONEY DEPOSIT (EMD): TO SAFE GUARD AGAINST A BIDDER'S WITHDRAWING OR ALTERING ITS/ HIS BID DURING THE BID VALIDITY PERIOD, BID SECURITY [ALSO KNOWN AS EARNEST MONEY DEPOSIT (EMD)] SHALL BE OBTAINED FROM THE BIDDERS ALONG WITH THEIR BIDS (EXCEPT MICRO AND SMALL ENTERPRISES (MSES) OR STARTUPS AS RECOGNIZED BY DEPARTMENT FOR PROMOTION OF INDUSTRY AND INTERNAL TRADE (DPIT)). THE AMOUNT OF EMD SHALL BE AS MENTIONED IN ENQUIRY. 1. MODES OF DEPOSIT A) THE EMD MAY BE ACCEPTED ONLY IN THE FOLLOWING FORMS AND THE SAME MUST BE SUBMITTED BEFORE TENDER OPENING: (I) ELECTRONIC FUND TRANSFER CREDITED IN BHEL ACCOUNT. (II) BANKER'S CHEQUE/ PAY ORDER/ DEMAND DRAFT, IN FAVOUR OF BHEL. (III) FIXED DEPOSIT RECEIPT (FDR).(IN THE NAME OF " BIDDER'S NAME A/C BHEL") (IV) BANK GUARANTEE FROM ANY OF THE SCHEDULED BANKS. (V) INSURANCE SURETY BONDS. B) IN CASE THE EMD IS MORE THAN RUPEES TWO LAKH AND IN CASE OF FOREIGN BIDDERS, IT MAY BE IN THE FORM OF A BANK GUARANTEE (IN EQUIVALENT FOREIGN EXCHANGE AMOUNT, IN CASE OF FOREIGN BIDDERS) ISSUED/ CONFIRMED FROM ANY OF THE SCHEDULED COMMERCIAL BANK IN INDIA IN AN ACCEPTABLE FORM. THE EMD SHALL REMAIN VALID FOR A PERIOD OF 45 (FORTY-FIVE) DAYS BEYOND THE FINAL BID VALIDITY PERIOD. 2. FORFEITURE OF EMD	

**GENERAL COMMERCIAL TERMS & CONDITIONS OF ENQUIRY
(FOR INDIAN VENDORS)**

Amendment- 27

ANNEXURE-A

	<p>I) A BIDDER'S EMD WILL BE FORFEITED IF THE BIDDER WITHDRAWS OR AMENDS ITS/HIS TENDER OR IMPAIRS OR DEROGATES FROM THE TENDER IN ANY RESPECT WITHIN THE PERIOD OF VALIDITY OF THE TENDER OR IF THE SUCCESSFUL BIDDER FAILS TO FURNISH THE REQUIRED PERFORMANCE SECURITY WITHIN THE SPECIFIED PERIOD MENTIONED IN THE TENDER.</p> <p>(II) EMD BY THE TENDERER SHALL BE WITHHELD IN CASE ANY ACTION ON THE BIDDER IS ENVISAGED UNDER THE PROVISIONS OF EXTANT "GUIDELINES ON SUSPENSION OF BUSINESS DEALINGS WITH SUPPLIERS/ CONTRACTORS" AND FORFEITED/ RELEASED BASED ON THE ACTION AS DETERMINED UNDER THESE GUIDELINES.</p> <p>3. RETURN OF EMD</p> <p>(I) BID SECURITIES OF THE UNSUCCESSFUL BIDDERS SHALL BE RETURNED TO BIDDER AT THE EARLIEST AFTER EXPIRY OF THE FINAL BID VALIDITY PERIOD AND LATEST BY THE 30TH DAY AFTER THE AWARD OF THE CONTRACT. HOWEVER, IN CASE OF TWO PACKET OR TWO STAGE BIDDING, BID SECURITIES OF UNSUCCESSFUL BIDDERS DURING FIRST STAGE I.E. TECHNICAL EVALUATION ETC. SHALL BE RETURNED WITHIN 30 DAYS OF DECLARATION OF RESULT OF FIRST STAGE I.E. TECHNICAL EVALUATION ETC.</p> <p>(II) BID SECURITY SHALL BE REFUNDED TO THE SUCCESSFUL BIDDER ON CONCLUSION OF THE ORDER/ RECEIPT OF A PERFORMANCE SECURITY (IF CALLED IN THE TENDER).</p> <p>(III) EMD SHALL NOT CARRY ANY INTEREST.</p>	
59.	<p>PERFORMANCE SECURITY (PS): TO ENSURE DUE PERFORMANCE OF THE CONTRACT, PERFORMANCE BANK GUARANTEE (PBG) OR SECURITY DEPOSIT (SD), HEREAFTER REFERRED AS PERFORMANCE SECURITY SHALL BE OBTAINED FROM THE SUCCESSFUL BIDDER AWARDED THE CONTRACT. THE PERFORMANCE SECURITY OF REQUIRED AMOUNT IS TO BE SUBMITTED BY THE DATE SPECIFIED IN THE PO/CONTRACT.</p> <p>1. MODES OF DEPOSIT:</p> <p>A) PERFORMANCE SECURITY MAY BE FURNISHED IN THE FOLLOWING FORMS:</p> <p>(I) LOCAL CHEQUES OF SCHEDULED BANKS (SUBJECT TO REALIZATION)/ PAY ORDER/ DEMAND DRAFT/ ELECTRONIC FUND TRANSFER IN FAVOUR OF BHEL.</p> <p>(II) BANK GUARANTEE FROM SCHEDULED BANKS / PUBLIC FINANCIAL INSTITUTIONS AS DEFINED IN THE COMPANIES ACT. THE BANK GUARANTEE FORMAT SHOULD HAVE THE APPROVAL OF BHEL.</p> <p>(III) FIXED DEPOSIT RECEIPT ISSUED BY SCHEDULED BANKS / PUBLIC FINANCIAL INSTITUTIONS AS DEFINED IN THE COMPANIES ACT (FDR SHOULD BE IN THE NAME OF THE CONTRACTOR, A/C BHEL).</p> <p>(IV) SECURITIES AVAILABLE FROM INDIAN POST OFFICES SUCH AS NATIONAL SAVINGS CERTIFICATES, KISAN VIKAS PATRAS ETC. (HELD IN THE NAME OF CONTRACTOR FURNISHING THE SECURITY AND DULY ENDORSED/ HYPOTHECATED/ PLEDGED, AS APPLICABLE, IN FAVOUR OF BHEL).</p> <p>(V) INSURANCE SURETY BOND.</p> <p>(NOTE: BHEL WILL NOT BE LIABLE OR RESPONSIBLE IN ANY MANNER FOR THE COLLECTION OF INTEREST OR RENEWAL OF THE DOCUMENTS OR IN ANY OTHER MATTER CONNECTED THEREWITH)</p> <p>B) IN CASE OF GTE TENDERS, THE PERFORMANCE SECURITY SHALL BE IN THE SAME CURRENCY AS THE CONTRACT AND MUST CONFORM TO UNIFORM RULES FOR DEMAND GUARANTEES (URDG 758) - AN INTERNATIONAL CONVENTION REGULATING INTERNATIONAL SECURITIES.</p> <p>(C) PERFORMANCE SECURITY IS TO BE FURNISHED WITHIN A SPECIFIED DATE (GENERALLY 14(FOURTEEN) DAYS AFTER NOTIFICATION OF THE AWARD) AND IT SHOULD REMAIN VALID FOR A PERIOD OF 60 (SIXTY) DAYS BEYOND THE DATE OF COMPLETION OF ALL CONTRACTUAL OBLIGATIONS OF THE SUPPLIER, INCLUDING WARRANTY OBLIGATIONS.</p> <p>"BIDDER AGREES TO SUBMIT PERFORMANCE SECURITY REQUIRED FOR EXECUTION OF THE CONTRACT WITHIN THE TIME PERIOD MENTIONED. IN CASE OF DELAY IN SUBMISSION OF PERFORMANCE SECURITY, ENHANCED PERFORMANCE SECURITY WHICH WOULD INCLUDE INTEREST (REPO RATE+4%) FOR THE DELAYED PERIOD, SHALL BE SUBMITTED BY THE BIDDER. FURTHER, IF PERFORMANCE SECURITY IS NOT SUBMITTED TILL SUCH TIME THE FIRST BILL BECOMES DUE, THE AMOUNT OF PERFORMANCE SECURITY DUE SHALL BE RECOVERED AS PER TERMS DEFINED IN NIT CONTRACT, FROM THE BILLS ALONG WITH DUE INTEREST"</p> <p>2. FORFEITURE OF PERFORMANCE SECURITY: THE PERFORMANCE SECURITY WILL BE FORFEITED AND CREDITED TO BHEL'S ACCOUNT IN THE EVENT OF A BREACH OF CONTRACT BY THE SUPPLIER.</p> <p>3. RETURN OF PERFORMANCE SECURITY (PS): PS SHALL BE REFUNDED TO THE BIDDER WITHOUT INTEREST, AFTER HE DULY PERFORMS AND COMPLETES THE CONTRACT IN ALL RESPECTS BUT NOT LATER THAN 60(SIXTY) DAYS OF COMPLETION OF ALL SUCH OBLIGATIONS INCLUDING THE WARRANTY UNDER THE CONTRACT.</p> <p>4. THE PERFORMANCE SECURITY SHALL NOT CARRY ANY INTEREST.</p>	
60.	<p>BREACH OF CONTRACT, REMEDIES AND TERMINATION:</p> <p>16.1 BREACH OF CONTRACT:</p> <p>THE FOLLOWING SHALL AMOUNT TO BREACH OF CONTRACT:</p> <p>I. NON-SUPPLY OF MATERIAL/ NON-COMPLETION OF WORK BY THE SUPPLIER/VENDOR WITHIN SCHEDULED DELIVERY/ COMPLETION PERIOD AS PER CONTRACT OR AS EXTENDED FROM TIME TO TIME.</p> <p>II. THE SUPPLIER/VENDOR FAILS TO PERFORM AS PER THE ACTIVITY SCHEDULE AND THERE ARE SUFFICIENT REASONS EVEN BEFORE EXPIRY OF THE DELIVERY/ COMPLETION PERIOD TO JUSTIFY THAT SUPPLIES SHALL BE INORDINATELY DELAYED BEYOND CONTRACTUAL DELIVERY/ COMPLETION PERIOD.</p> <p>III. THE SUPPLIER/VENDOR DELIVERS EQUIPMENT/ MATERIAL NOT OF THE CONTRACTED QUALITY.</p> <p>IV. THE SUPPLIER/VENDOR FAILS TO REPLACE THE DEFECTIVE EQUIPMENT/ MATERIAL/ COMPONENT AS PER GUARANTEE CLAUSE.</p> <p>V. WITHDRAWAL FROM OR ABANDONMENT OF THE WORK BY THE SUPPLIER/VENDOR BEFORE COMPLETION AS PER CONTRACT.</p> <p>VI. ASSIGNMENT, TRANSFER, SUBLLETING OF CONTRACT BY THE SUPPLIER/VENDOR WITHOUT BHEL'S WRITTEN PERMISSION RESULTING IN TERMINATION OF CONTRACT OR PART THEREOF BY BHEL.</p> <p>VII. NON-COMPLIANCE TO ANY CONTRACTUAL CONDITION OR ANY OTHER DEFAULT ATTRIBUTABLE TO SUPPLIER/VENDOR.</p> <p>VIII. ANY OTHER REASON(S) ATTRIBUTABLE TO VENDOR TOWARDS FAILURE OF PERFORMANCE OF CONTRACT. IN CASE OF BREACH OF CONTRACT, BHEL SHALL HAVE THE RIGHT TO TERMINATE THE PURCHASE ORDER/ CONTRACT EITHER IN WHOLE OR IN PART THEREOF WITHOUT ANY COMPENSATION TO THE SUPPLIER/VENDOR.</p> <p>IX. ANY OF THE DECLARATIONS FURNISHED BY THE CONTRACTOR AT THE TIME OF BIDDING AND/ OR ENTERING INTO THE CONTRACT FOR SUPPLY ARE FOUND UNTRUTHFUL AND SUCH DECLARATIONS WERE OF A NATURE THAT COULD HAVE RESULTED IN NON-AWARD OF CONTRACT TO THE CONTRACTOR OR COULD EXPOSE BHEL AND/ OR OWNER TO ADVERSE CONSEQUENCES, FINANCIAL OR OTHERWISE.</p> <p>X. SUPPLIER/VENDOR IS CONVICTED OF ANY OFFENCE INVOLVING CORRUPT BUSINESS PRACTICES, ANTI-NATIONAL ACTIVITIES OR ANY SUCH OFFENCE THAT COMPROMISES THE BUSINESS ETHICS OF BHEL, IN VIOLATION OF THE INTEGRITY PACT ENTERED INTO WITH BHEL HAS THE POTENTIAL TO HARM THE OVERALL BUSINESS OF BHEL/ OWNER</p> <p>NOTE- ONCE BHEL CONSIDERS THAT A BREACH OF CONTRACT HAS OCCURRED ON THE PART OF SUPPLIER/VENDOR, BHEL SHALL NOTIFY THE SUPPLIER/VENDOR BY WAY OF NOTICE IN THIS REGARD. CONTRACTOR SHALL BE GIVEN AN OPPORTUNITY TO RECTIFY THE REASONS CAUSING THE BREACH OF CONTRACT WITHIN A PERIOD OF 14 DAYS.</p> <p>IN CASE THE CONTRACTOR FAILS TO REMEDY THE BREACH, AS MENTIONED IN THE NOTICE, TO THE SATISFACTION OF BHEL, BHEL SHALL HAVE THE RIGHT TO TAKE RECOURSE TO ANY OF THE REMEDIAL ACTIONS AVAILABLE TO IT UNDER THE RELEVANT PROVISIONS OF CONTRACT</p> <p>16.2 REMEDIES IN CASE OF BREACH OF CONTRACT.</p> <p>I. WHEREIN THE PERIOD AS STIPULATED IN THE NOTICE ISSUED UNDER CLAUSE 14.1 HAS EXPIRED AND SUPPLIER/VENDOR HAS FAILED TO REMEDY THE BREACH, BHEL WILL HAVE THE RIGHT TO TERMINATE THE CONTRACT ON THE GROUND OF "BREACH OF CONTRACT" WITHOUT ANY FURTHER NOTICE TO CONTRACTOR.</p> <p>II. UPON TERMINATION OF CONTRACT, BHEL SHALL BE ENTITLED TO RECOVER AN AMOUNT EQUIVALENT TO 10% OF THE CONTRACT VALUE FOR THE DAMAGES ON ACCOUNT OF BREACH OF CONTRACT COMMITTED BY THE SUPPLIER/VENDOR. THIS AMOUNT SHALL BE RECOVERED BY WAY OF ENCASHING THE SECURITY INSTRUMENTS LIKE PERFORMANCE BANK GUARANTEE ETC AVAILABLE WITH BHEL AGAINST THE SAID CONTRACT. IN CASE THE VALUE OF THE SECURITY INSTRUMENTS AVAILABLE IS LESS THAN 10% OF THE CONTRACT VALUE, THE BALANCE AMOUNT SHALL BE RECOVERED FROM OTHER FINANCIAL REMEDIES (I.E. AVAILABLE BILLS OF THE SUPPLIER/VENDOR, RETENTION AMOUNT, FROM THE MONEY DUE TO THE SUPPLIER/VENDOR ETC. WITH BHEL) OR THE OTHER LEGAL REMEDIES SHALL BE PURSUED</p>	

**GENERAL COMMERCIAL TERMS & CONDITIONS OF ENQUIRY
(FOR INDIAN VENDORS)**

Amendment- 27
ANNEXURE-A

	<p>III. WHEREVER THE VALUE OF SECURITY INSTRUMENTS LIKE PERFORMANCE BANK GUARANTEE AVAILABLE WITH BHEL AGAINST THE SAID CONTRACT IS 10% OF THE CONTRACT VALUE OR MORE, SUCH SECURITY INSTRUMENTS TO THE EXTENT OF 10% CONTRACT VALUE WILL BE ENCASHED. IN CASE NO SECURITY INSTRUMENTS ARE AVAILABLE OR THE VALUE OF THE SECURITY INSTRUMENTS AVAILABLE IS LESS THAN 10% OF THE CONTRACT VALUE, THE 10% OF THE CONTRACT VALUE OR THE BALANCE AMOUNT, AS THE CASE MAY BE, WILL BE RECOVERED IN ALL OR ANY OF THE FOLLOWING MANNERS:</p> <p>IV. IN CASE THE AMOUNT RECOVERED UNDER SUB CLAUSE (A) ABOVE IS NOT SUFFICIENT TO FULFIL THE AMOUNT RECOVERABLE THEN; A DEMAND NOTICE TO DEPOSIT THE BALANCE AMOUNT WITHIN 30 DAYS SHALL BE ISSUED TO SUPPLIER/VENDOR.</p> <p>V. IF SUPPLIER/VENDOR FAILS TO DEPOSIT THE BALANCE AMOUNT WITHIN THE PERIOD AS PRESCRIBED IN DEMAND NOTICE, FOLLOWING ACTION SHALL BE TAKEN FOR RECOVERY OF THE BALANCE AMOUNT:</p> <p>A. FROM DUES AVAILABLE IN THE FORM OF BILLS PAYABLE TO DEFAULTED SUPPLIER/VENDOR AGAINST THE SAME CONTRACT.</p> <p>B. IF IT IS NOT POSSIBLE TO RECOVER THE DUES AVAILABLE FROM THE SAME CONTRACT OR DUES ARE INSUFFICIENT TO MEET THE RECOVERABLE AMOUNT, BALANCE AMOUNT SHALL BE RECOVERED FROM ANY MONEY(S) PAYABLE TO SUPPLIER/VENDOR UNDER ANY CONTRACT WITH OTHER UNITS OF BHEL INCLUDING RECOVERY FROM SECURITY DEPOSITS OR ANY OTHER DEPOSIT AVAILABLE IN THE FORM OF SECURITY INSTRUMENTS OF ANY KIND AGAINST SECURITY DEPOSIT OR EMD.</p> <p>C. IN-CASE RECOVERIES ARE NOT POSSIBLE WITH ANY OF THE ABOVE AVAILABLE OPTIONS, LEGAL ACTION SHALL BE INITIATED FOR RECOVERY AGAINST DEFAULTED SUPPLIER/VENDOR.</p> <p>VI. IT IS AN AGREED TERM OF CONTRACT THAT THIS AMOUNT SHALL BE A GENUINE PRE-ESTIMATE OF DAMAGES THAT BHEL WOULD INCUR IN COMPLETION OF BALANCE CONTRACTUAL OBLIGATION OF THE CONTRACT THROUGH ANY OTHER AGENCY AND BHEL WILL NOT BE REQUIRED TO FURNISH ANY OTHER EVIDENCE TO THE SUPPLIER/VENDOR FOR THE PURPOSE OF ESTIMATION OF DAMAGES.</p> <p>VII. IN ADDITION TO THE ABOVE, IMPOSITION OF LIQUIDATED DAMAGES, DEBARMENT, TERMINATION, DE-SCOPING, SHORT-CLOSURE, ETC., SHALL BE APPLIED AS PER PROVISIONS OF THE CONTRACT.</p> <p>NOTE: 1) THE DEFAULTING SUPPLIER/VENDOR SHALL NOT BE ELIGIBLE FOR PARTICIPATION IN ANY OF THE FUTURE ENQUIRIES FLOATED BY BHEL TO COMPLETE THE BALANCE WORK. THE DEFAULTING CONTRACTOR SHALL MEAN AND INCLUDE:</p> <p>(A) IN CASE DEFAULTED SUPPLIER/VENDOR IS THE SOLE PROPRIETORSHIP FIRM, ANY SOLE PROPRIETORSHIP FIRM OWNED BY SAME SOLE PROPRIETOR</p> <p>(B) IN CASE DEFAULTED SUPPLIER/VENDOR IS THE PARTNERSHIP FIRM, ANY FIRM COMPRISING OF SAME PARTNERS/ SOME OF THE SAME PARTNERS ; OR SOLE PROPRIETORSHIP FIRM OWNED BY ANY PARTNER(S) AS A SOLE PROPRIETOR.</p>	
61.	<p>NO INTEREST PAYABLE TO CONTRACTOR: NOTWITHSTANDING ANYTHING TO THE CONTRARY CONTAINED IN ANY OTHER DOCUMENT COMPRISING IN THE CONTRACT, NO INTEREST SHALL BE PAYABLE BY BHEL TO CONTRACTOR ON ANY MONEYS OR BALANCES INCLUDING BUT NOT LIMITED TO THE SECURITY DEPOSIT, EMD, RETENTION MONEY, RA BILLS OR THE FINAL BILL, OR ANY AMOUNT WITHHELD AND/OR APPROPRIATED BY BHEL ETC., WHICH BECOMES OR AS THE CASE MAY BE, IS ADJUDGED TO BE DUE FROM BHEL TO CONTRACTOR WHETHER UNDER THE CONTRACT OR OTHERWISE</p>	
62.	<p>OVER RUN CHARGES: NO OVERRUN CHARGES ARE APPLICABLE</p>	
63.	<p>ORDER OF PRECEDENCE: THE PURCHASE ORDER ALONG WITH ITS ANNEXURES THE NIT, ITS AMENDMENTS /CORRIGENDUM'S SHALL ALL TOGETHER CONSTITUTE THE ENTIRE CONTRACT BETWEEN THE PARTIES AND SHALL BE COMPLEMENTARY TO ONE ANOTHER. IN CASE OF ANY CONTRADICTION, THE ORDER OF PRECEDENCE SHALL BE AS BELOW:</p> <ol style="list-style-type: none"> a. PURCHASE ORDER ALONG WITH ITS ANNEXURES b. AMENDMENTS/CLARIFICATIONS/CORRIGENDA/ERRATA ETC. ISSUED IN RESPECT OF THE TENDER DOCUMENTS BY BHEL. c. NIT 	
64.	<p>OTHER POINTS: YOU SHALL HAVE TO OBSERVE ALL WORK QUALITY, SAFETY REGULATIONS, GENERAL TECHNICAL GUIDE LINES AS STIPULATED IN RELEVANT CLAUSES TENDER SPECIFICATION. YOU SHALL SUBMIT PROGRESS REPORTS TO BHEL AS PER TENDER CONDITIONS, REVIEW THE PROGRAMME FROM TIME TO TIME AND TAKE SUITABLE STEPS TO MEET OVERALL PROJECT SCHEDULE, IN CONSULTATION WITH BHEL/ BIFCL ENGINEER</p> <p>VENDOR SHOULD FOLLOW THE AGREED TENDER TERM (CL. NO. 29.0 OF GTC) STRICTLY: -- "THE OFFERS OF THE BIDDERS WHO ARE ON THE BANNED LIST AS ALSO THE OFFER OF THE BIDDERS, WHO ENGAGE THE SERVICES OF THE BANNED FIRMS, SHALL BE REJECTED. THE LIST OF BANNED FIRMS IS AVAILABLE ON BHEL WEB SITE WWW.BHEL.COM)".</p> <p>ALL OTHER TERMS & CONDITIONS NOT COVERED HERE SHALL BE AS PER THOSE SPECIFIED IN THE TENDER DOCUMENT (NIT) ALONG WITH TCNS INCLUDING TECHNICAL SPECIFICATION, SPECIFIC CONDITIONS OF CONTRACT & GENERAL CONDITIONS OF CONTRACT.</p> <p>YOU ARE REQUESTED TO SEND US THE ACKNOWLEDGEMENT AS PER SPECIFIED FORMAT AND CONVEY YOUR UNQUALIFIED ACCEPTANCE TO THIS PURCHASE ORDER AS PER ENCLOSED ANNEXURE-X WITHIN 7 (SEVEN) DAYS ELSE IT WILL BE DEEMED ACCEPTED.</p>	
65.	<p>FOR SUPPLY ORDERS PLACED ON INDIAN SUPPLIERS:</p> <p>IRRESPECTIVE OF THE VALUE OF THE INVOICE AMOUNT, THE BIDDER / VENDOR SHOULD NECESSARILY UPLOAD THE DESPATCH & INVOICE DETAILS ON BHEL SUVIDHA PORTAL AT HTTPS://SUVIDHA.BHEL.IN/SUVIDHA/, PRIOR TO DESPATCH. ALL DOCUMENTS AS PER PO CHECKLIST , ALONG WITH ADDITIONAL DOCUMENTS (IF ANY), MUST BE UPLADED ON THE PORTAL. IT IS MANDATORY THAT TAX INVOICES WITH A NET AMOUNT (INCLUDING TAXES) EXCEEDING RS FIVE LAKHS UPLADED ON THE PORTAL ARE DIGITALLY SIGNED USING A CLASS 3 DIGITAL SIGNATURE CERTIFICATE (DSC) ISSUED BY A LICENSED CERTIFYING AUTHORITY. SUBMISSION OF INVOICE DOCUMENT IN HARD COPY IS ALLOWED FOR INVOICES WITH A NET AMOUNT (INCLUDING TAXES) EQUAL TO AND UPTO RS FIVE LAKHS , IN CASE THEY WERE NOT DIGITALLY SIGNED AND UPLADED ON THE PORTAL.</p> <p>THE MATERIAL WILL NOT BE ACCEPTED INSIDE BHEL IN ABSENCE OF THE ABOVE</p>	

GENERAL COMMERCIAL TERMS & CONDITIONS OF ENQUIRY
(FOR INDIAN VENDORS)

Amendment- 27
ANNEXURE-A

66.	<p>GRIEVANCE REDRESSAL MECHANISM:</p> <p>TO PROMOTE TRANSPARENCY AND ENSURE FAIR TREATMENT OF ALL BIDDERS, A STRUCTURED GRIEVANCE REDRESSAL MECHANISM IS IN PLACE TO ADDRESS ANY CONCERNS OR ISSUES ARISING DURING THE TENDERING PROCESS OR IN SUBSEQUENT BUSINESS DEALINGS WITH THE COMPANY.</p> <p>SUPPLIERS/CONTRACTORS ARE REQUESTED TO FOLLOW THE BELOW ESCALATION PROCESS FOR GRIEVANCE RESOLUTION:</p> <ol style="list-style-type: none">1. FIRST LEVEL: ANY GRIEVANCE SHOULD INITIALLY BE ADDRESSED TO THE DESIGNATED DEALING OFFICER, WHOSE CONTACT DETAILS ARE PROVIDED IN THE NOTICE INVITING TENDER (NIT)/CONTRACT. <p>SECOND LEVEL: IF THE ISSUE REMAINS UNRESOLVED, IT MAY BE ESCALATED BY LODGING A FORMAL GRIEVANCE THROUGH THE SUVIDHA PORTAL: HTTPS://SUVIDHA.BHEL.IN/SUVIDHA/. RESPONSES WILL BE PROVIDED IN ACCORDANCE WITH THE DEFINED ESCALATION MATRIX</p>	
-----	---	--

NOTE:

1. PLEASE FILL IN THIS FORMAT AND SEND COMPULSORILY ALONG WITH QUOTATION WITH VENDOR'S SEAL, SIGNATURE AND DATE.

SIGNATURE ALONG WITH SEAL AND DATE:

Umesh Kumar Gupta
DGM(Pur.)

Ashok Kr. Srivastava
DGM(Fin)

Enq.No.
Vendor Name
Quotation No.
Quotation Date

TECHNICAL CONDITION

Sl.No.	Description	Vendor Response	Comment
1	Technical condition as per NIT		
2	Acceptance of items and their quantity as per NIT		
3	Quoted for all the items of NIT		
4	Delivery Period as per NIT		
5	Submission of Guarantee/Warranty certificate as per NIT		
6	Submission of Test Certificate as per NIT		
7	Submission of Inspection Certificate as per NIT		
8	Acceptance of packing instruction/condition as per NIT		

COMMERCIAL CONDITION

Sl.No.	Description	Vendor Response	Comment
1	Delivery Term <i>(Insurance will be in vendor scope if delivery term is accepted as BHEL Store)</i>		
2	MSE Status		
3	Payment Term		
4	Validity of offer as per NIT		
5	GST Type		
6	LD Clause as per GTC		
7	Risk purchase as per NIT		
8	Firm Price : The quoted/finalized rates shall be firm till execution of supplies. <i>Offer with PVC (Price Variation Clause) will not be considered.</i>		
9	Submission of Bank Guarantee		
10	Acceptance of Reverse Auction clause of NIT		
11	I have read & understood all terms and conditions of GTC and hereby give my acceptance on the same		

NOTE Vendors have to write in "Comment" box only if their response is not available in drop down menu.

Annexure – MSEs 2012 Rev 01

OWNERSHIP STATUS (SC/ ST OR WOMEN-OWNED OR OTHERS) UNDER MSE
(Mandatory for all Non-GeM tenders and custom bids on GeM)

In order to avail benefits of MSE under various categories, all Bidders falling under MSE category shall furnish the following details & submit documentary evidence/ Govt. Certificate etc. in support of the same along with their techno-commercial offer.

Type under MSE	SC/ST Owned	Women Owned	Others (excluding SC/ST & Women Owned)
Micro			
Small			

(Bidder details with Sign and date)

Note: In case party is falling under any of the above category, they shall mention **YES** in the against the box.

On Bidder's office letter pad

Make in India (Model Certificate) Annexure-I

Self-Declaration

Enquiry No.	
Enquiry Date	

In line with Government public procurement order Number P-45021/2/2017-B.E-II dated 15.06.2017, and further modified order dt. 28.05.2018, 29.05-2019, 04.06.2020 and 19.07.2024.

I / We hereby declare that I / We are a "Local Supplier" meeting the requirement of minimum local content (.....%) defined in the above government notification for the goods against above mentioned enquiry Number.

Details of location at which local value addition will be made is as follows:

Door No.	
Street / Address 1	
Street / Address 2	
District	
State	
Country	
PIN Code	

We also understand that the false declarations will be considered as breach of Integrity and liable for action.

For Company Name:

Seal:

Signature:

Date:

Place :

(Please fill all Yellow color field)

APP 166 - FIRST ANGLE PROJECTION (ALL DIMENSIONS IN MILLIMETRES)

REV	DATE	ALTERED	BY	REV	DATE	ALTERED
01	12-3-76	K. RAMESH	02			
		CHECKED	K. M. RAO			CHECKED

VAR NO-04, 05&06 ADDED
WT 1.186 WAS 0.088 KGS.

CAUTION THE INFORMATION ON THIS DOCUMENT IS THE PROPERTY OF BHARAT HEAVY ELECTRICALS LTD. IT MUST NOT BE USED DIRECTLY OR INDIRECTLY IN ANY WAY DETRIMENTAL TO THE INTEREST OF THE COMPANY

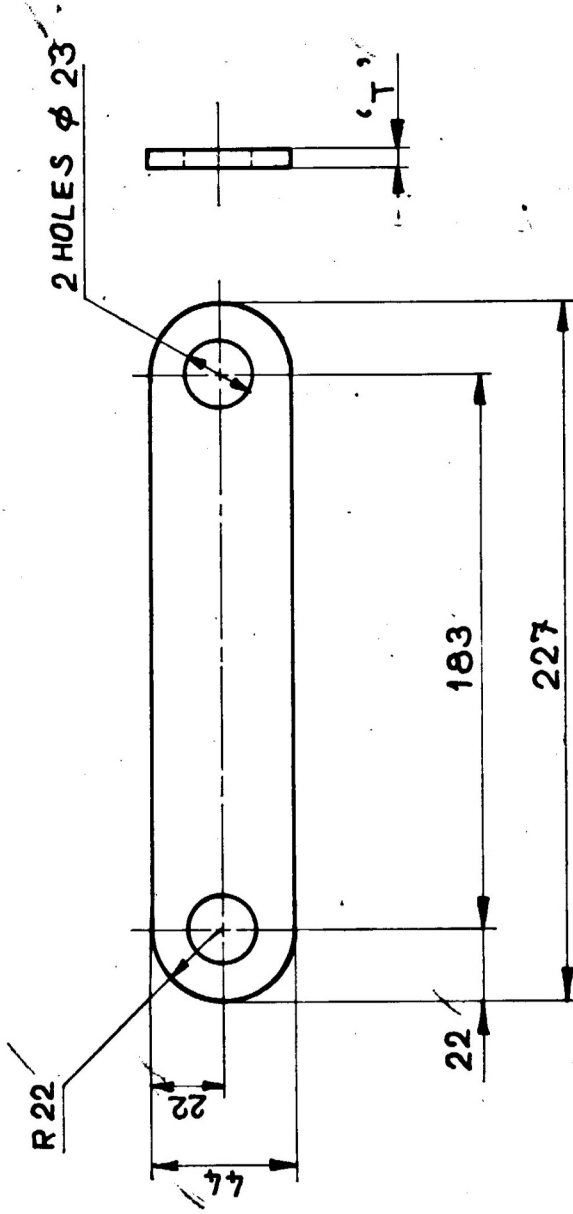

GENERAL DIMENSIONS, LIMITS, FITS & TOLERANCES AS PER PS. HY 0230261

SD MAT CODE - 849617284278

QTY	UNIT WT	DESCRIPTION	MATL CODE	MATL SPEC
06	0.274	SHIM 4 X 44 X 227	AA10131XXX	
05	0.137	SHIM 2 X 44 X 227	IS 1993	
04	0.069	SHIM 1 X 44 X 227	AA10131XXX	
03	0.001	SHIM 0.30 x 44 x 227	IS 1993	
02	0.000	SHIM 0.10 x 44 x 227	AA 10131XXX	
01	0.000	SHIM 0.05 x 44 x 227	IS 1993	

1082-179



Bharat Heavy Electricals Ltd.,
BOILER PLANT UNIT
TIRUCHIRAPALLI-620 014

DEPT. MILUS	SCALE	WEIGHT (kg)	REF TO ASSY / OLD DRG	DATE
CODE 240	NTS	1.186	B-GP-3964-0	13.8.07
				24/09/87
				29/9/87

TITLE
GRINDING ROLL SHIM SET

CARD CODE
U 01

DRAWING NO.

4-61-080-00961 0

DRG. NO. 3-61-100-00520

SHT. 01 OF 01

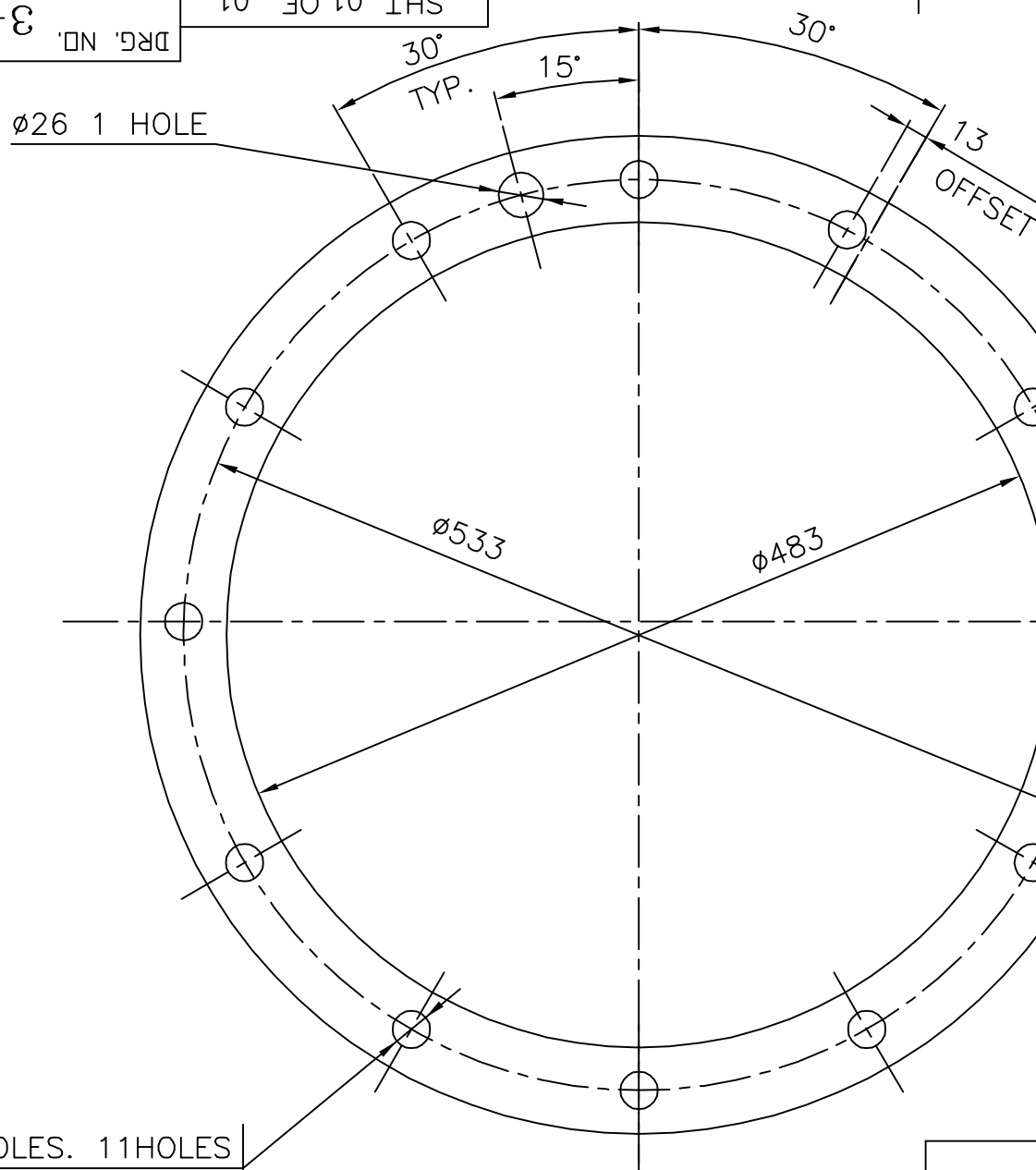

SEE "T" DIM

VARIANT No.	RECOM.QTY. SHIM SET	"T" DIM (MM SIZE)	"T" DIM (INCH SIZE)	WEIGHT PER PIECE
01	2	0.05	0.003"	0.050
02	2	0.10	0.005"	0.080
03	2	0.20	0.012"	0.200

TOTAL WEIGHT PER SET : 0.660 KGS.

NOTE:-

- SHIMS TO BE MACHINE CUT & FREE OF SCALE AND FOREIGN MATTER
- MATERIAL SPECIFICATION IS: 1993 GR FIRST(PRIME)

Ø22-12 HOLES. 11HOLES
EQUALLY SPACED ON A
12-HOLE PATTERN 1 HOLE
OFFSET AS SHOWN

01	SHIM SET-LOWER BRG. HSG. COVER				BA9717283028	0.660	
					AA10131		1
ITEM NO.	DESCRIPTION	STD.	DRAWING NO.	VAR. NO.	MATERIAL CODE	NET WT.	GROSS WT.
					MATERIAL SPECN.	QUANTITY	

THE INFORMATION ON THIS DOCUMENT IS THE PROPERTY OF BHARAT HEAVY ELECTRICALS LIMITED. IT MUST NOT BE USED DIRECTLY OR INDIRECTLY IN ANY WAY DETRIMENTAL TO THE INTEREST OF THE COMPANY

COMPUTER FILE NAME
36100520.DWG

SIGN. AND DATE REF. DRG. NO.

INVENTORY NO

FOR RECOMMENDED SHIM SET SEE TABLE

REV.	DATE	ALTERED	REV.	DATE	ALTERED
02	25.02.99	CHD/APPD	01	14.10.96	CHD/APPD
ZONE	DRAWING REDRAWN IN AUTO CAD		ZONE	NOTE 02 ADDED, 'MM' SIZE FOR DIM 'T' ADDED. NOTE MODIFIED.	

THE FOLLOWING CONDITIONS APPLY EXCEPT OTHERWISE STATED...

- REF.TO HY0230261 FOR UNSPECIFIED TOLERANCES.
- CHAMFER M/CD SHARP EDGES 1.2 TO 1.0 AT 45°.
- INTERNAL M/CD CORNER RADII 1 TO 0.7.
- THE SURFACE ROUGHNESS WHEREVER NOT SHOWN SHALL BE TAKEN FROM THE SURFACE ROUGHNESS SHOWN OUT SIDE BACK SLASHES GIVEN AT THE TOP MOST RIGHT CORNER OF THE DRG.

TYPE OF PRODUCT OR NAME OF CUSTOMER/PROJECT
1003 XRP BOWL MILL

	BHARAT HEAVY ELECTRICALS LTD.		DRN.	NAME	SIGN.	DATE	NO.OF VAR.
	HYDERABAD		CHD.	E.M.A		25.2.93	03
			APPD.	S.G		25.2.93	

DEPT. PULV. ENGG CODE 446	UNTOL. DIMS. GR. \varnothing /M/Ø	SCALE N.T.S	WEIGHT (KG) 0.660	REF. TO ASSY. DRG.	ITEM NO. -	NO.OF ITEMS -
------------------------------	-------------------------------------	-------------	-------------------	--------------------	------------	---------------

TITLE SHIM SET LOWER BEARING HOUSING COVER	DRAWING NO. 3-61-100-00520	REV. 02
	SHT. No 01	NO. OF SHT. 01

COMPUTER FILE NAME: 36100682.DWG

DRG. NO. 3-61-000-19-3
28900-000-19-3

4 HOLES DIA 16 THRU
EQ. SPACED ON
P.C.D. 737

12 HOLES DIA 35 THRU
EQ. SPACED ON P.C.D. 737

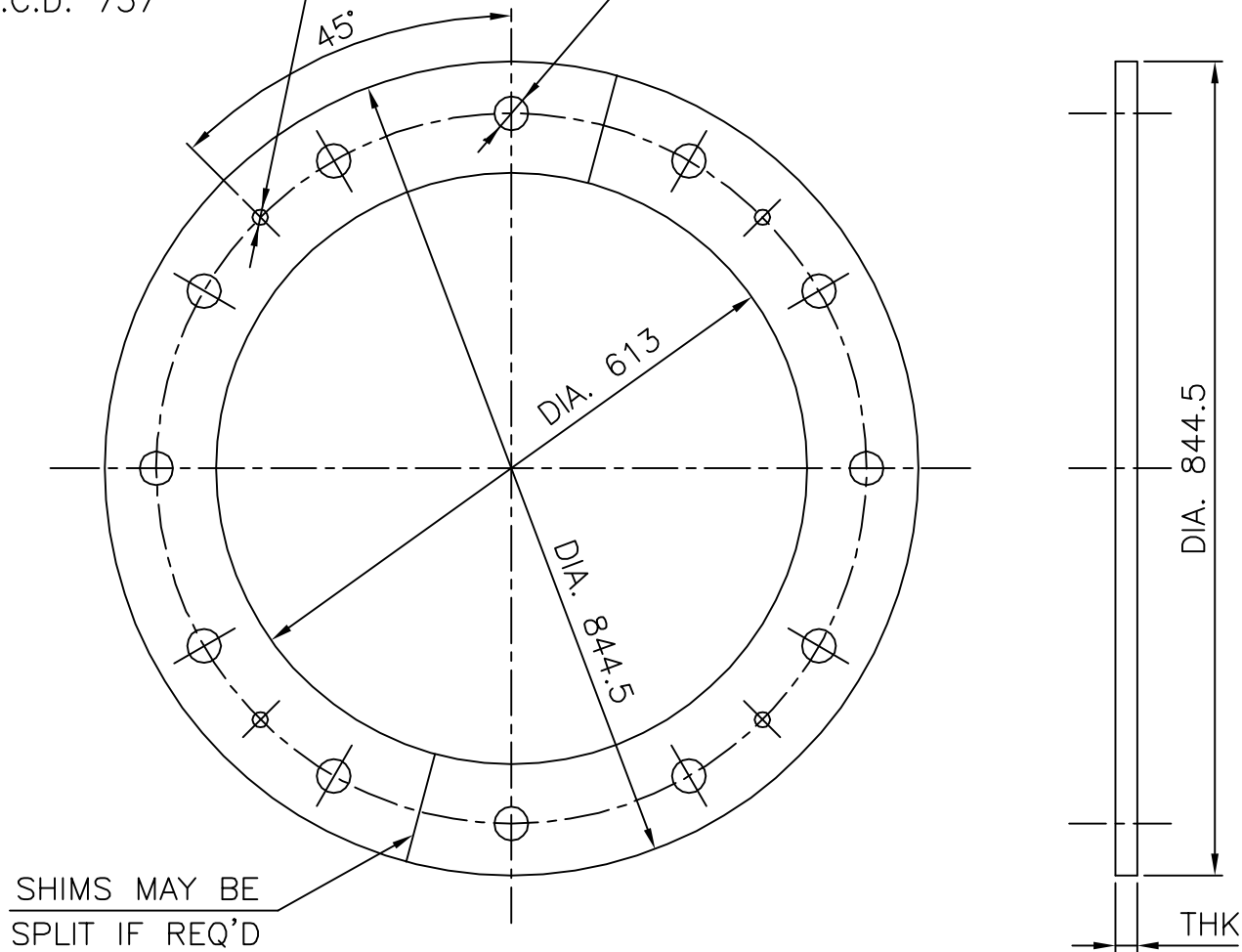

ITEM NO.	DESCRIPTION	STD.	DRAWING NO.	VAR. NO.	MATERIAL CODE	NET WT.	GROSS WT.
					MATERIAL SPECN.	QUANTITY	
04	SHIM THK. 0.8				BA9717283389	1.567	
							3
03	SHIM THK. 0.4				BA9717283389	0.754	
							3
02	SHIM THK. 0.15				BA9717283389	0.258	
							2
01	SHIM THK. 0.1				BA9717283389	0.159	
							2

SIGN. AND DATE REF. DRG. NO. INVENTORY NO.

REV.	DATE	ALTERED	E.M.ASHOK	REV.	DATE	ALTERED	
02	4.2.04	CHD/APPD	AMAN	01	2.4.99	CHD/APPD	
ZONE	DRG REDRAWN.			ZONE	THKS 0.10,0.15&0.80 WERE 0.08,0.13&0.79 RESPLY. DRG REDRAWN.		

THE FOLLOWING CONDITIONS APPLY EXCEPT OTHERWISE STATED...

- REF.TO HY0230261 FOR UNSPECIFIED TOLERANCES.
- CHAMFER M/CD SHARP EDGES 1.2 TO 1.0 AT 45°.
- INTERNAL M/CD CORNER RADII 1 TO 0.7.
- THE SURFACE ROUGHNESS WHEREVER NOT SHOWN SHALL BE TAKEN FROM THE SURFACE ROUGHNESS SHOWN OUT SIDE BACK SLASHES GIVEN AT THE TOP MOST RIGHT CORNER OF THE DRG.

TYPE OF PRODUCT OR NAME OF CUSTOMER/PROJECT

1003 XRP BOWL MILL

 BHARAT HEAVY ELECTRICALS LTD. HYDERABAD	DRN.	NAME	SIGN.	DATE	NO.OF VAR.
	CHD.	AMAN/NDS	<i>[Signature]</i>	4.2.04	-NA-
	APPD.	S.G	<i>[Signature]</i>	4.2.04	-NA-

DEPT. PULV.ENGG	UNTOL. DIMS. GR. ϕ /M/F	SCALE NTS	WEIGHT (KG) 7.797	REF. TO ASSY. DRG. B-101-01079/00	ITEM NO. -NA-	NO.OF ITEMS -NA-
-----------------	------------------------------	-----------	-------------------	-----------------------------------	---------------	------------------

TITLE: **UPPER JOURNAL HSG. SHIM SET**

DRAWING NO. **3-61-000-00682** REV. **02**

SHT. No 01 NO. OF SHT. 01

DRG. NO. 3-61-000-19-3
62900-000-19-3

COMPUTER FILE NAME THE INFORMATION ON THIS DOCUMENT IS THE PROPERTY OF BHARAT HEAVY ELECTRICALS LIMITED. IT MUST NOT BE USED DIRECTLY OR INDIRECTLY IN ANY WAY DETRIMENTAL TO THE INTEREST OF THE COMPANY
36100679.DWG

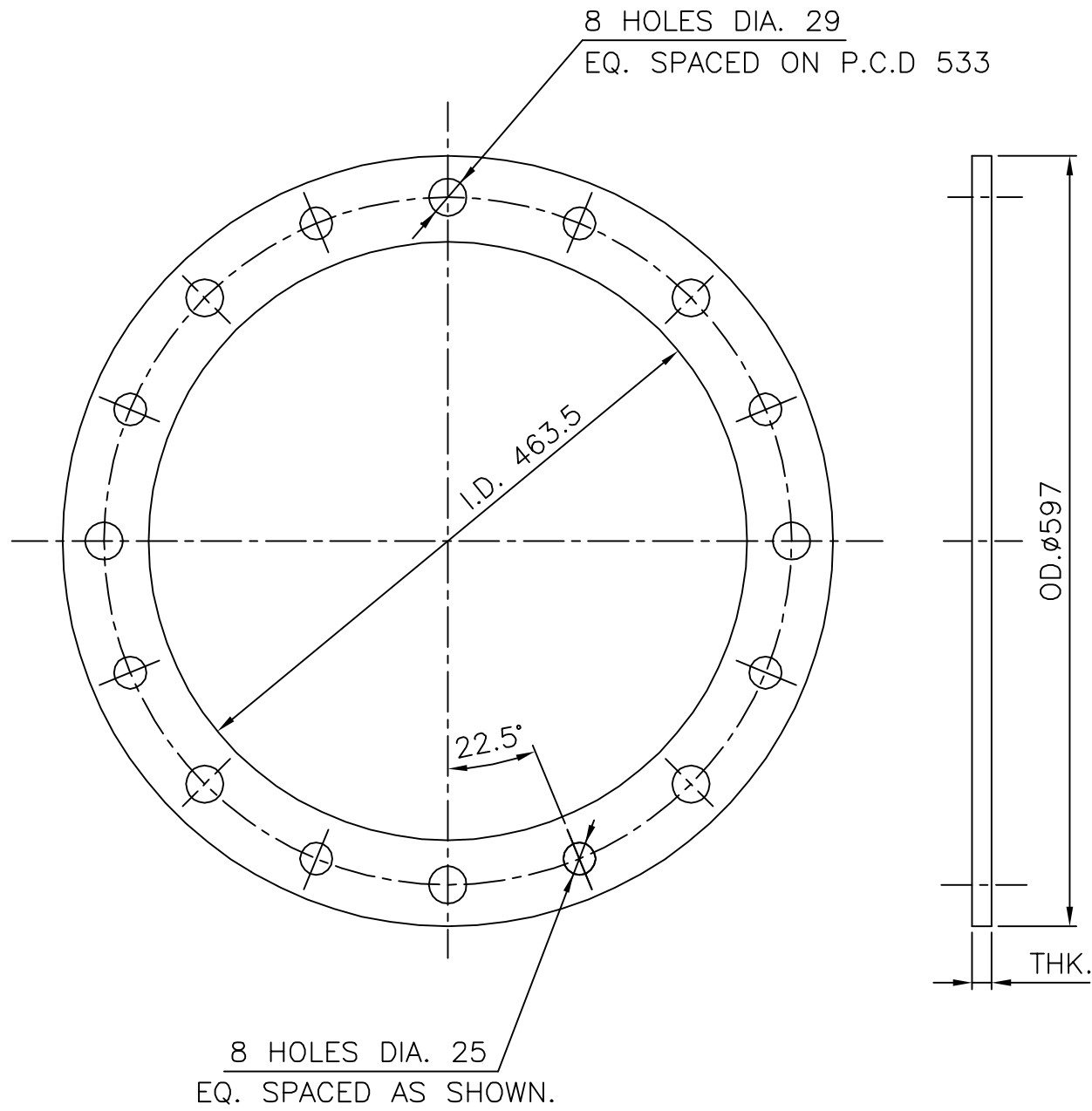

ITEM NO.	DESCRIPTION	STD.	DRAWING NO.	VAR. NO.	MATERIAL CODE	NET WT.	GROSS WT.
04	SHIM THK. 0.8				BA9717283370	0.292	
							1
03	SHIM THK. 0.30				BA9717283370	0.111	
							3
02	SHIM THK. 0.15				BA9717283370	0.048	
							2
01	SHIM THK. 0.10				BA9717283370	0.030	
							2
					MATERIAL SPECN.	QUANTITY	

INVENTORY NO SIGN. AND DATE REF. DRG. NO.

REV.	DATE	ALTERED	E.M.ASHOK	REV.	DATE	ALTERED
02	4.2.04	CHD/APPD	AMAN	01	2.4.99	CHD/APPD
ZONE	DRG REDRAWN.			ZONE	THKS 0.10,0.15&0.80 WERE 0.08,0.13&0.79 RESPLY. DRG REDRAWN.	

THE FOLLOWING CONDITIONS APPLY EXCEPT OTHERWISE STATED...

- REF.TO HY0230261 FOR UNSPECIFIED TOLERANCES.
- CHAMFER M/CD SHARP EDGES 1.2 TO 1.0 AT 45°.
- INTERNAL M/CD CORNER RADII 1 TO 0.7.
- THE SURFACE ROUGHNESS WHEREVER NOT SHOWN SHALL BE TAKEN FROM THE SURFACE ROUGHNESS SHOWN OUT SIDE BACK SLASHES GIVEN AT THE TOP MOST RIGHT CORNER OF THE DRG.

TYPE OF PRODUCT OR NAME OF CUSTOMER/PROJECT
1003 XRP BOWL MILL

	BHARAT HEAVY ELECTRICALS LTD., HYDERABAD			
	DRN.	NAME	SIGN.	DATE
	CHD.	AMAN		4.2.04
APPD.	S.G		4.2.04	NO.OF VAR. -NA-

DEPT. PULV.ENG	UNTOL. DIMS. GR. ϕ /M/F		SCALE N.T.S	WEIGHT (KG) 0.781	REF. TO ASSY. DRG. B-110-00319/02	ITEM NO. -NA-	NO.OF ITEMS -NA-
----------------	------------------------------	--	-------------	-------------------	-----------------------------------	---------------	------------------

TITLE	DRAWING NO.	REV.
UPPER BEARING KEEPER SHIM SET	3-61-000-00679	02
	SHT. No 01	NO. OF SHT. 01

2-61-004-02263
DRG. NO.

SH. 01 OF 01

INVENTORY NO. SIGN. AND DATE REF. DRG. NO. C-110-00777/01 C-61-004-00571 COMPUTER FILE NAME 26102263.DWG THE INFORMATION ON THIS DOCUMENT IS THE PROPERTY OF BHARAT HEAVY ELECTRICALS LIMITED. IT MUST NOT BE USED DIRECTLY OR INDIRECTLY IN ANY WAY DETRIMENTAL TO THE INTEREST OF THE COMPANY

GENERAL DIMENSIONAL LIMITS, FITS & TOLERANCES AS PER HY0230261

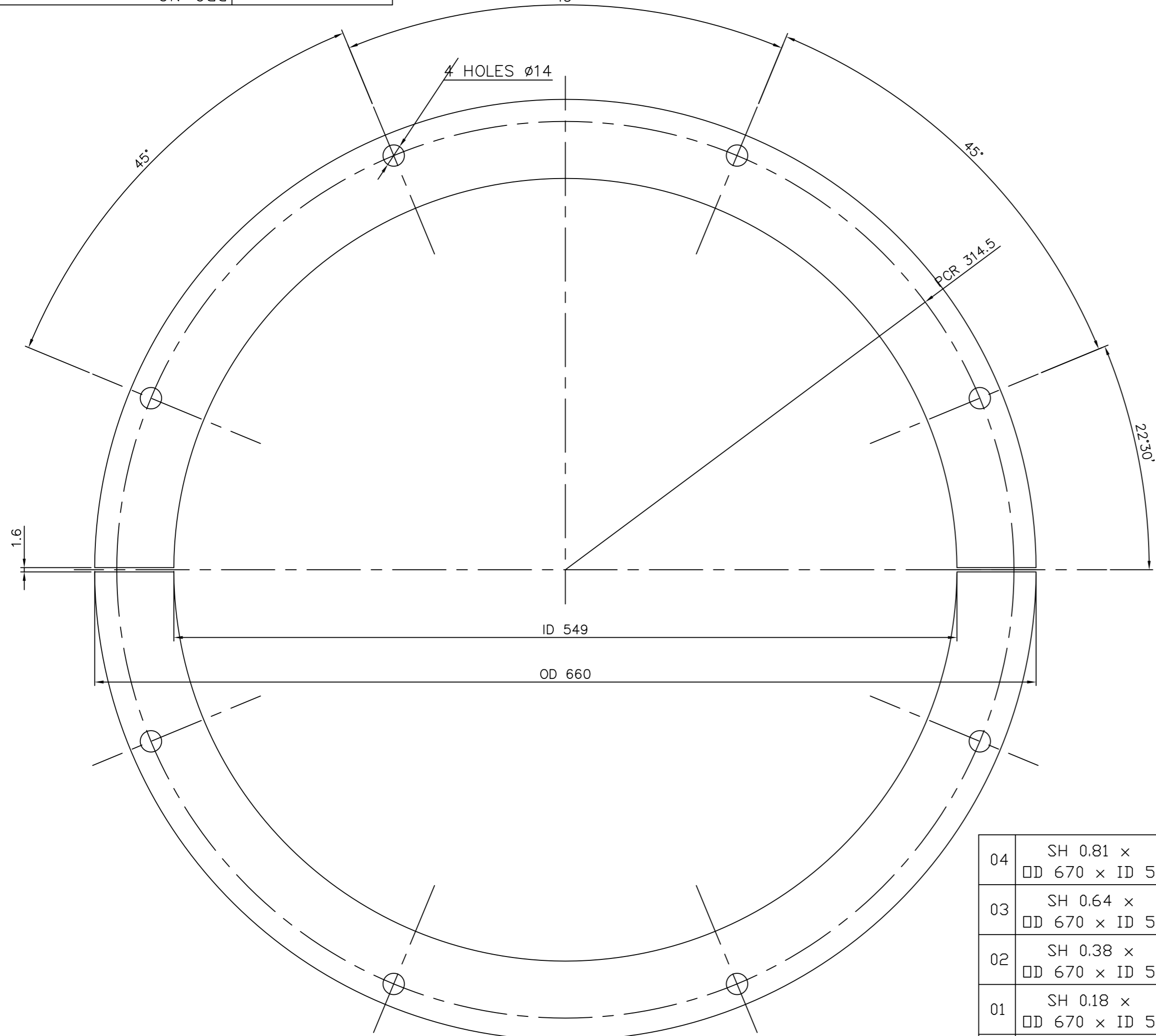

VAR. No.	DIM 'T'
01	0.18
02	0.38
03	0.64
04	0.81

NOTE: -

- SHIMS TO BE MACHINE CUT & FREE OF SCALE & FOREIGN MATTER.

MATL. BA9717282080

ITEM NO	DESCRIPTION	DRAWING NO.	VAR. NO.	RAW MATERIAL SIZE OF CASTING DRG.NO. OR FORGING DRG.NO.	MATERIAL CODE	NET WT.	GROSS WT.
					MATERIAL SPECN.	QUANTITY	
04	SH 0.81 x OD 670 x ID 540				AA 10114	1	0.390
03	SH 0.64 x OD 670 x ID 540				AA 10114	1	0.310
02	SH 0.38 x OD 670 x ID 540				AA 10114	1	0.180
01	SH 0.18 x OD 670 x ID 540				AA 10114	1	0.090

THE FOLLOWING CONDITIONS APPLY EXCEPT OTHERWISE STATED...

- REF. TO HY0230261 FOR UNSPECIFIED TOLERANCES.
- CHAMFER M/CD SHARP EDGES 1.2 TO 1.0 AT 45°.
- INTERNAL M/CD CORNER RADII 1 TO 0.7.
- THE SURFACE ROUGHNESS WHEREVER NOT SHOWN SHALL BE TAKEN FROM THE SURFACE ROUGHNESS SHOWN OUT SIDE BACK SLASHES GIVEN AT THE TOP MOST RIGHT CORNER OF THE DRG.

TYPE OF PRODUCT OR NAME OF CUSTOMER/PROJECT **1103 XRP BOWL MILL**

BHARAT HEAVY ELECTRICALS LTD. HYDERABAD	NAME	SIGN.	DATE	NO. OF VAR.
	DRN. C.C.S.		10.6.99	
	CHD. E.M.A.		10.6.99	
APPD. K.M.RAD		10.6.99		
DEPT. PULV	UNTOL. DIMS. GR. G/M/F	SCALE 1:2	WEIGHT (KG) 0.970	REF. TO ASSY. DRG. C-61-004-00571
CODE 446				ITEM NO. 16 NO. OF ITEMS 32
TITLE AIR SEAL RING - SHIM SET		CARD CODE N.A.	DRAWING NO. 2-61-004-02263 REV. 02	
		SHT. No 01	NO. OF SHT. 01	

REV.	DATE	ALTERED	REV.	DATE	ALTERED	REV.	DATE	ALTERED	REV.	DATE	ALTERED
		CHD/APPD			CHD/APPD			CHD/APPD			CHD/APPD
02	15.12.10		01	10.6.99		01	10.6.99		01	10.6.99	
ZONE			ZONE			ZONE			ZONE		
											SHIM WAS HALF RING
											DRG. REDRAWN IN AUTO CAD



CORPORATE PURCHASING SPECIFICATION

AA 10131

Rev. No. 05

PAGE 1 OF 4

COLD-REDUCED MILD STEEL SHIMS

1.0 GENERAL:

This specification governs the quality requirements of Cold Mild Steel Shims of thickness 0.05 to 0.49 mm, supplied in the form of sheets in coils.

2.0 APPLICATION:

For shims and other general engineering purposes.

3.0 CONDITION OF DELIVERY:

Cold-Reduced sheets in coils.

4.0 COMPLIANCE WITH NATIONAL STANDARDS:

There is no Indian standard covering this thickness of material. However, assistance has been derived from IS:2385.

5.0 DIMENSIONS AND TOLERANCES:

5.1 Sizes:

Material shall be supplied to the dimensions specified on the order.

5.2 Tolerances:

The thickness of shim/sheet shall comply with the following:

5.2.1 Thickness:

Average thickness of consignment:

The mean of the thickness of each lot of 5 sheets selected from a package shall not deviate from the ordered nominal thickness by more than ± 2.5 percent.

Average thickness of individual sheet:

The average thickness of any of the 5 sample sheets selected from a package shall not deviate by more than ± 8.5 percent from the ordered nominal thickness.

Variation within a sheet:

The thickness of an individual specimen shall not deviate by more than ± 4 percent from the average thickness of the sheet.

5.2.2 Length and Width:

+ 5 mm
- 0 mm

Revisions : Ref: e-mail from
B.Choudary,HW dt.19.02.2009

APPROVED :Interplant Material
Rationalisation Committee - MRC S&GPS

Rev. No. 05

Amd.No.

Reaffirmed

Prepared

Issued

Dt. of 1st Issue

Dt.20.2.2009

Dt :

Year :

BHOPAL

Corp. R&D

Aug. 76

COPYRIGHT AND CONFIDENTIAL
The Information on this document is the property of BHARAT HEAVY ELECTRICALS LIMITED
It must not be used directly or indirectly in any way detrimental to the Interest of the company.



5.2.3 Shape:

Flatness:

Sheet shall be commercially flat when placed vertical and horizontal positions.

Sheets hanging from vertical position shall not show bowing of more than 5 mm.

Edge waviness:

Sheet lying on a flat surface shall not show edge waviness of more than 3 mm.

Squareness:

The maximum out of squareness shall not normally exceed 0.15 percent of the length. However, 5 percent of the sheet may exceed this limit to a maximum of 0.25%.

Camber:

Maximum camber on any edge shall be such that the deviation from the straight line does not exceed 0.15 percent on any side.

6.0 MANUFACTURE :

The method of manufacture of the material shall be at the discretion of manufacturer.

7.0 TREATMENT:

The hot-rolled strip shall be pickled, cold-reduced with or without intermediate annealing and cleaned, annealed and finally temper-rolled, if necessary, to obtain the desired condition of the material and surface.

8.0 FREEDOM FROM DEFECTS:

The material shall be free from cracks, pitting, blisters, laminations and other surface defects.

9.0 CHEMICAL COMPOSITION :

The melt analysis of steel and permissible variation in the composition of the material from the melt analysis shall be as follows:

Element	Percent, Max.	Permissible variation, Percent, Max.
Carbon	0.12	0.02
Manganese	0.60	0.03
Sulphur	0.050	0.005
Phosphorus	0.050	0.005

10.0 TEST SAMPLES:

Hardness Test:

One sample shall be selected from each package.

**11.0 HARDNESS (VICKERS):**

When tested in accordance with IS: 1501, the test pieces shall have a Vicker's hardness in the range of 80-120 HV.

12.0 INSPECTION AT SUPPLIERS' WORKS :

Whenever specified, tests and inspection are to be conducted in the presence of BHEL's representative.

BHEL's representative shall have free access at all times while the work on the contract is being performed, to all parts of the manufacturer's works. The manufacturer shall offer BHEL's representative all reasonable facilities without charge to satisfy the latter that the material is being furnished in accordance with this specification. The manufacturer shall prepare and provide necessary test specimens for testing to be carried out at his premises. If facilities do not exist at his works, the manufacturer shall make necessary arrangements for carrying out the prescribed tests elsewhere. The manufacturer shall notify BHEL's representative in advance about the readiness of the material for inspection and testing.

BHEL reserves the right to test the material at BHEL's works and the final acceptance of the material shall be based on these test results.

13.0 TEST CERTIFICATES :

Three copies of test certificates shall be supplied unless otherwise stated on the order.

In addition, the supplier shall ensure to enclose one copy of the test certificate along with their despatch documents to facilitate quick clearance of the material.

The test certificate shall bear the following information :

BHEL References :

AA 10131 : Rev.No. 05

BHEL Order No.

Supplier's References :

Name

Identification No.

Melt No.

Process of manufacture.

Results of tests :

Dimensional inspection.

Results of chemical analysis and mechanical tests.

14.0 PACKING AND MARKING :**14.1 Packing:**

The material shall be supplied in coils of continuous strip. The nominal weight of each coil shall be 1800-2000kg. The nominal internal diameter of coil shall be 500 mm.

Sheet shall be protected to prevent damage and rusting during transit.

Sheet shall be packed in line with IS: 2385.

**14.2 Marking:**

A metal label shall be securely attached to each bundle and shall be marked with the following:

AA 101 31 : Cold - Reduced M.S Shims
BHEL Order No.
Consignment / Identification No.
Weight, Size and Thickness
Supplier's Name and Grade
Melt No.
Packet/ Bundle No.

15.0 REJECTION AND REPLACEMENT :

If the material does not comply with the requirements of this specification during receipt inspection at BHEL or any defect is found during the course of further processing, such material shall be rejected notwithstanding any previous certification of satisfactory testing and/or inspection.

The manufacturer shall undertake to replace the rejected material of his own cost and the rejected material shall be taken back by the supplier after fulfilling the commercial terms and conditions.

16.0 REFERRED STANDARDS :

The following is the list of the latest standards, as published by the respective issuing bodies, referred to in this specification.

1. IS:228

2. IS:1501

3. IS:2385

08900-000-19-3
DRG. NO.

8 HOLES DIA. 19
EQ. SPACED ON P.C.D 591

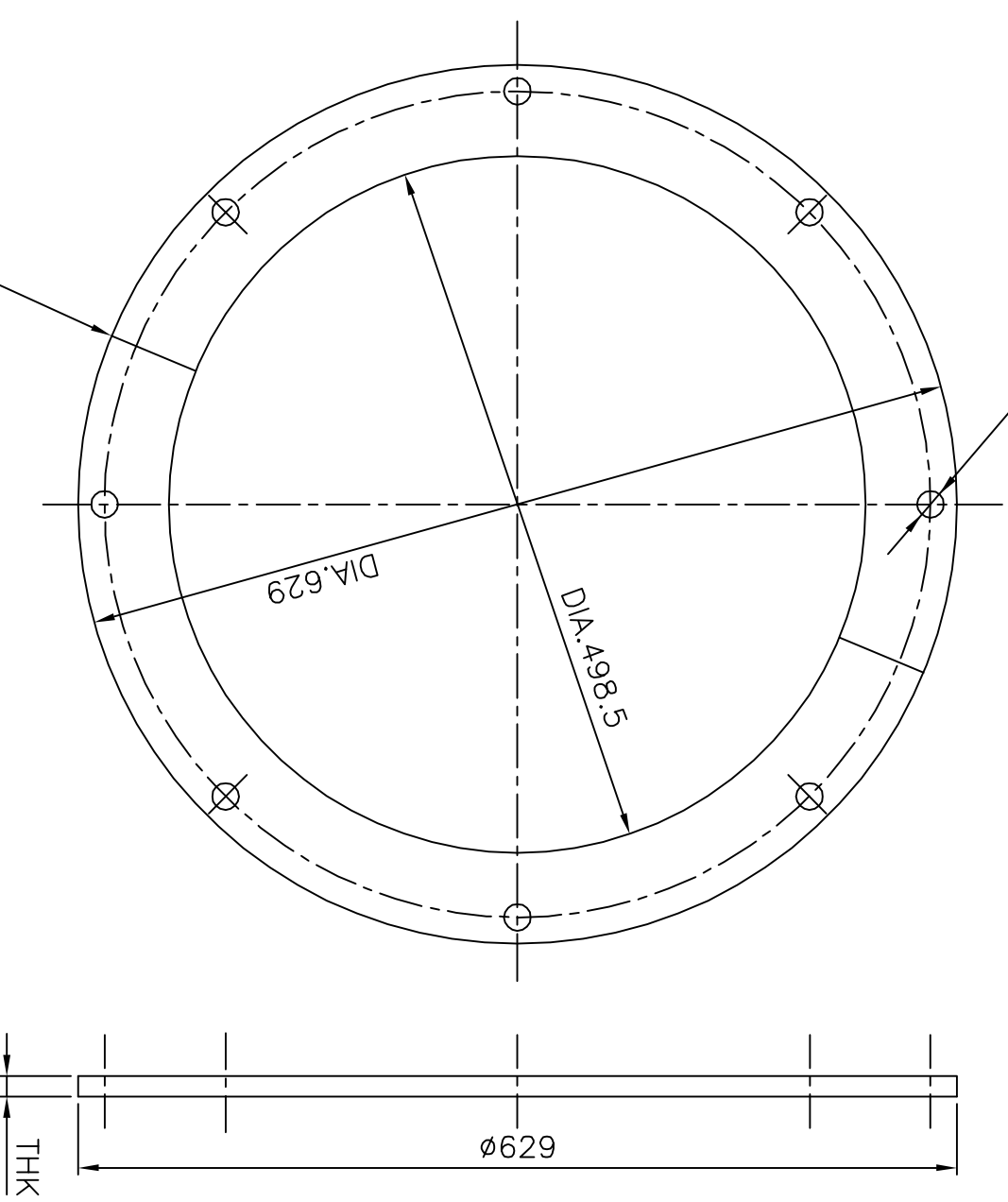

COMPUTER FILE NAME
36100680.DWG

THE INFORMATION ON THIS DOCUMENT IS THE PROPERTY OF BHARAT HEAVY ELECTRICALS LIMITED. IT MUST NOT BE USED DIRECTLY OR INDIRECTLY IN ANY WAY DETRIMENTAL TO THE INTEREST OF THE COMPANY

INVENTORY NO
SIGN. AND DATE
REF. DRG. NO.

REV.	DATE	ALTERED	E.M.ASHOK	REV.	DATE	ALTERED
02	4.2.04	CHD/APPD	AMAN	01	2.4.99	CHD/APPD
ZONE DRG REDRAWN.				ZONE THKS 0.10,0.15&0.80 WERE 0.08,0.13&0.79 RESPLY. DRG REDRAWN.		

THE FOLLOWING CONDITIONS APPLY EXCEPT OTHERWISE STATED...

1. REF.TO HY0230261 FOR UNSPECIFIED TOLERANCES.
2. CHAMFER M/CD SHARP EDGES 1.2 TO 1.0 AT 45°.
3. INTERNAL M/CD CORNER RADII 1 TO 0.7.
4. THE SURFACE ROUGHNESS WHEREVER NOT SHOWN SHALL BE TAKEN FROM THE SURFACE ROUGHNESS SHOWN OUT SIDE BACK SLASHES GIVEN AT THE TOP MOST RIGHT CORNER OF THE DRG.

ITEM NO.	DESCRIPTION	IS	DRAWING NO.	VAR. NO.	MATERIAL CODE	NET WT.	GROSS WT.
04	SHIM THK. 0.8				BA9717283362	0.703	1
03	SHIM THK. 0.6				BA9717283362	0.569	2
02	SHIM THK. 0.4				BA9717283362	0.338	2
01	SHIM THK. 0.2				BA9717283362	0.205	2

TYPE OF PRODUCT
DR
NAME OF CUSTOMER/PROJECT
1003 XRP BOWL MILL

DEPT. PULVENECS
CODE 446

UNTDL. DIMS. GR. f/m/y

SCALE N.T.S

WEIGHT (KG) 2.927

REF. TD ASSY. DRG. B-110-00916/00

DRN. E.M.ASHOK
CHD. AMAN
APPD. S.G.

NAME SIGN. DATE

DATE 4.2.04
DATE 4.2.04
DATE 4.2.04

ITEM NO. -NA-
ITEMS -NA-
REV. -NA-

TITLE
AIR SEAL RING SHIM SET

DRAWING NO.
3-61-000-006801

SHT. No 01
ND. OF SHT. 01

82900-000-19-3.DWG

3 HOLES DIA.27
EQ. SPACED ON PCD 178

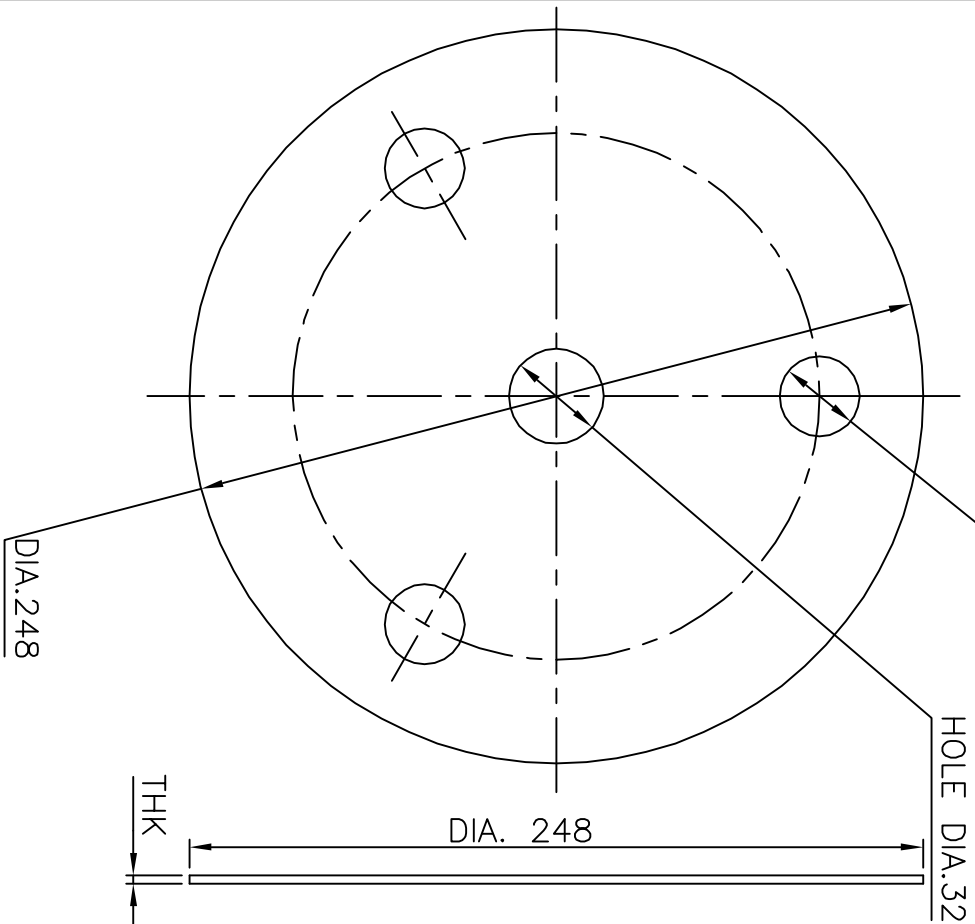

- NOTES:-**
- 01. SHIMS TO BE MACHINE CUT & FREE OF SCALE & FOREIGN MATTER.
 - * 02. MATERIAL SPECIFICATION
STEEL SHIM STOCK COMM. QUALITY.

ITEM NO	DESCRIPTION	DRAWING NO.	VAR. NO.	RAW MATERIAL SIZE OR CASTING DRG.NO. OR FORGING DRG.NO.	MATERIAL CODE	NET WT.	GROSS WT.
04	SHIM THK 0.79					0.284	
						*	1
					BA9717283109	0.108	
						*	3
						0.047	
						*	2
						0.029	
						*	2

THE FOLLOWING CONDITIONS APPLY EXCEPT OTHERWISE STATED...
 1. REF.TO HY0230261 FOR UNSPECIFIED TOLERANCES.
 2. CHAMFER M/CD SHARP EDGES 1.2 TO 1.0 AT 45°.
 3. INTERNAL M/CD CORNER RADII 1 TO 0.7.
 4. THE SURFACE ROUGHNESS WHEREVER NOT SHOWN SHALL BE TAKEN FROM THE SURFACE ROUGHNESS SHOWN OUT SIDE BACK SLASHES GIVEN AT THE TOP MOST RIGHT CORNER OF THE DRG.

TYPE OF PRODUCT OR NAME OF CUSTOMER/PROJECT		1003 XRP BOWL MILL	
DEPT. PULV ENGG.		BHARAT HEAVY ELECTRICALS LTD. HYDERABAD	
SCALE	WEIGHT (kg)	REF. TO ASSY DRG.	ITEM NO.
1:2.5	0.760	B-110-00323/01	970830
TITLE		DRAWING NO.	
JOURNAL BRG. KEEPER SHIM SET		3-61-000-00678 01	
SHEET NO. 01		NO OF SHEETS 01	

REV.	DATE	ALTERED	UNIC
01	960906	CHD.	APPD.
DRAWING REDRAWN			

FIRST ANGLE PROJECTION

ALL DIMENSIONS ARE IN mm.

REV. 02	DATE 22.03.03	ALTERED PAVAN KUMAR CHECKED APPROVED	REV. 03	DATE 06.04.04	ALTERED PAVAN KUMAR CHECKED S.GHATGE APPROVED	REV. 04	DATE 7.7.06	ALTERED AMAN CHECKED S.GHATGE APPROVED
DRG. REDRAWN BY INCORPORATING ALL PREVIOUS REVISIONS.			TOL ADDED ON $\phi 505$. $\phi 14$ WAS $\phi 12$.			DIM $\phi 503$ WAS $\phi 505$		

INVENTORY NO. SIGN. & DATE REF. DRG. NO. COMPUTER NO. THE INFORMATION ON THIS DOCUMENT IS THE PROPERTY OF BHARAT HEAVY ELECTRICALS LIMITED. IT MUST NOT BE USED DIRECTLY OR INDIRECTLY IN ANY WAY DETRIMENTAL TO THE INTEREST OF THE COMPANY.

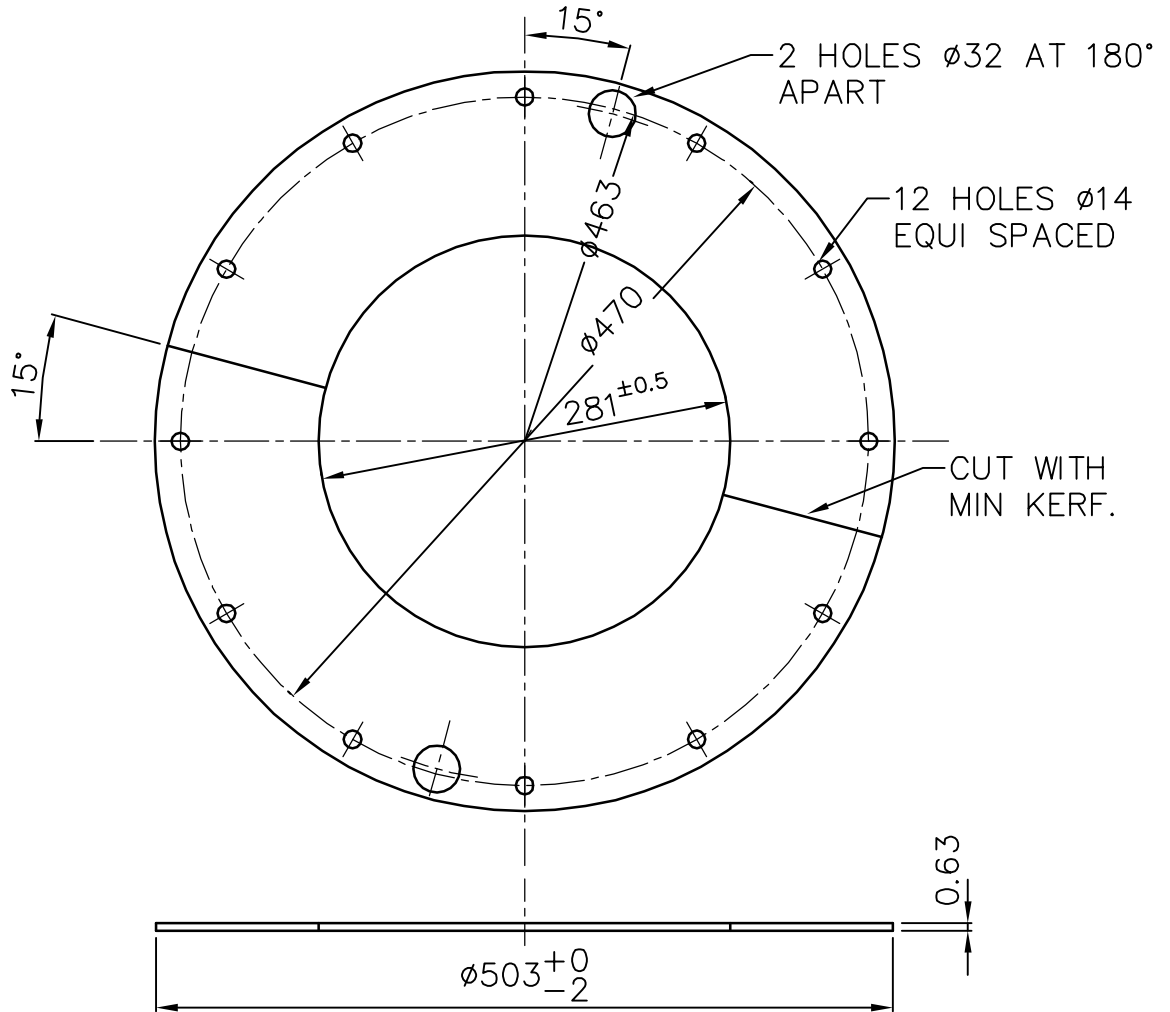

TO BE MATCH MACHINED ALONG WITH SPACER RING (46118000682) GASKET (46118000683)

SHIM		SH. 0.63x520x520	BA9617284138	0.260	
			AA10114		1
DESCRIPTION & DRG.NO.	VAR NO.	RAW MATERIAL SIZE OR CASTING DRG.NO. OR FORGING DRG.NO.	MATL. CODE	NET.WT.	GROSS WT
			MATL. SPECN.	QTY.	

TYPE OF PRODUCT OR NAME OF CUSTOMER/PROJECT

REF. TO HY0230261 FOR UNSPECIFIED TOLERANCES.		BHARAT HEAVY ELECTRICALS LTD. HYDERABAD		NAME	SIGN	DATE	NO.OF VAR.
		DRN.	B.PAVAN KUMAR		22.3.03		
		CKD.	N.D.SAMUEL		22.3.03		
			APPD.	SATISH GHATGE		22.3.03	
DEPT. PULV.ENGG		SCALE 1:5	WEIGHT(K.G.) 0.260	REF.TO ASSY.DRG. 4-61-176-00312	ITEM NO. /	NO.OF ITEM /	
CODE 446							
TITLE SHIM				DRAWING NO. 4-61-180-00680		REV. 04	
				SHT.NO. 01	NO.OF SHT. 01		

REV.	DATE	ALTERED	EMA	REV.	DATE	ALTERED	EMA	REV.	DATE	ALTERED	
01	4.1.03	CHECKED	NDS	02	12.8.03	CHECKED	NDS			CHECKED	
		APPROVED	SG			APPROVED	SG			APPROVED	
DRAWING REDRAWN ON AUTOCAD				8 HOLES EQUI. SPACED SHOWN CORRECTLY.							

6.3 ✓

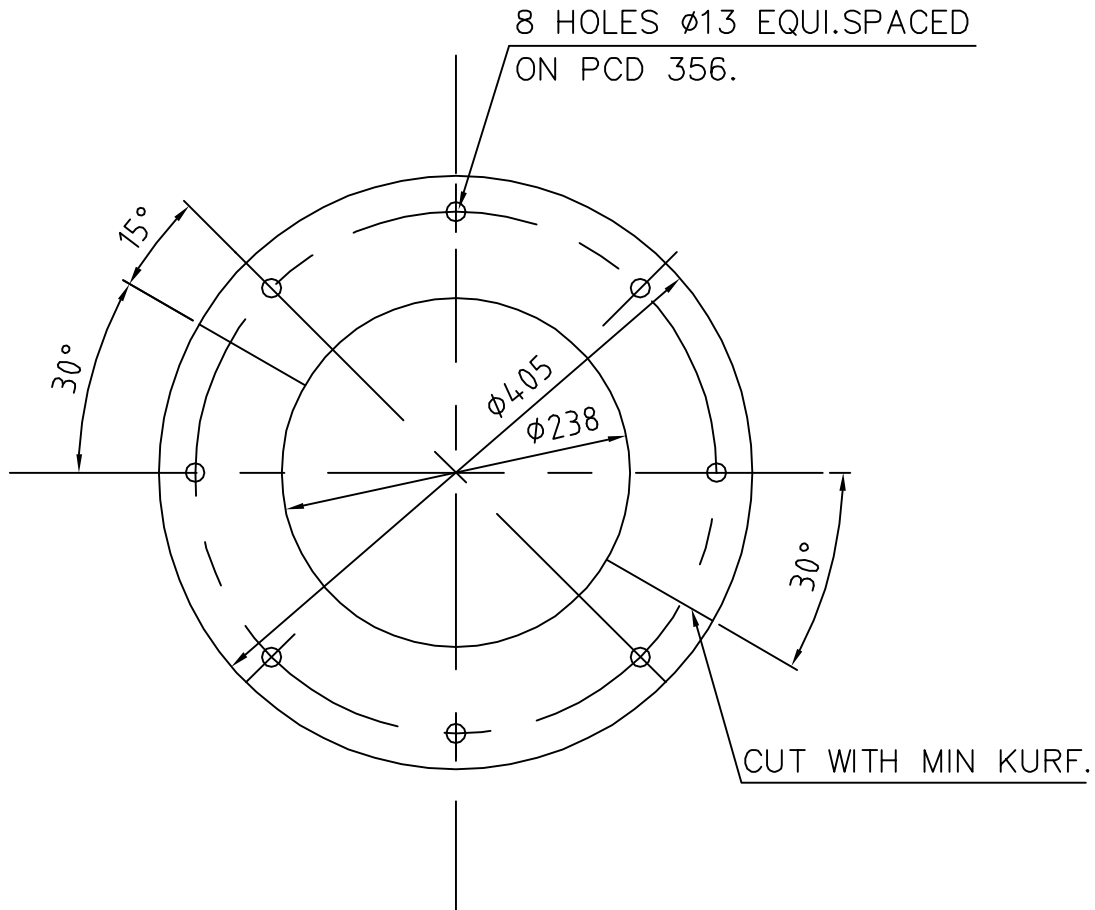

THE INFORMATION ON THIS DOCUMENT IS THE PROPERTY OF BHARAT HEAVY ELECTRICALS LIMITED. IT MUST NOT BE USED DIRECTLY OR INDIRECTLY IN ANY WAY DETRIMENTAL TO THE INTEREST OF THE COMPANY.

COMPUTER NO. 46100694
REF. DRG. NO.
SIGN & DATE
INVENTORY NO.

SHEET		SH.0.63XØ405	-BA9617284200	0.417	
					1
DESCRIPTION & DRG.NO.	VAR NO.	RAW MATERIAL SIZE OR CASTING DRG.NO. OR FORGING DRG.NO.	MATL. CODE	NET.WT.	GROSS WT
			MATL. SPECN.	QTY.	

TYPE OF PRODUCT OR NAME OF CUSTOMER/PROJECT

BHARAT HEAVY ELECTRICALS LTD. HYDERABAD	DRN.	RAZVI		4.1.03	NO.OF VAR.	
	CKD.	N.D.S.	<i>[Signature]</i>	4.1.03		
	APPD.	SG	<i>[Signature]</i>	4.1.03		
DEPT. PULV.ENGG		SCALE 1:5	WEIGHT(K.G.) 0.417	REF.TO ASSY.DRG. -	ITEM NO. -	NO.OF ITEM -
CODE 446						
TITLE				DRAWING NO.		REV.
SHIM				4-61-162-00694		02
			SHT.NO. 01	NO.OF SHT. 01		

FIRST ANGLE PROJECTION

(ALL DIMENSIONS IN mm)

REV. 01	DATE 14.04.97	ALTERED UC	REV. 02	DATE 13.11.04	ALTERED	ADDITIONAL INFORMATION
		CHECKED N.D.S			CHECKED	
		APPROVED S.G			APPROVED S.G	
DRG. REDRAWN ON AUTOCAD.			NOTE 2 MODIFIED. INCH REMOVED FROM VAR TABLE.			

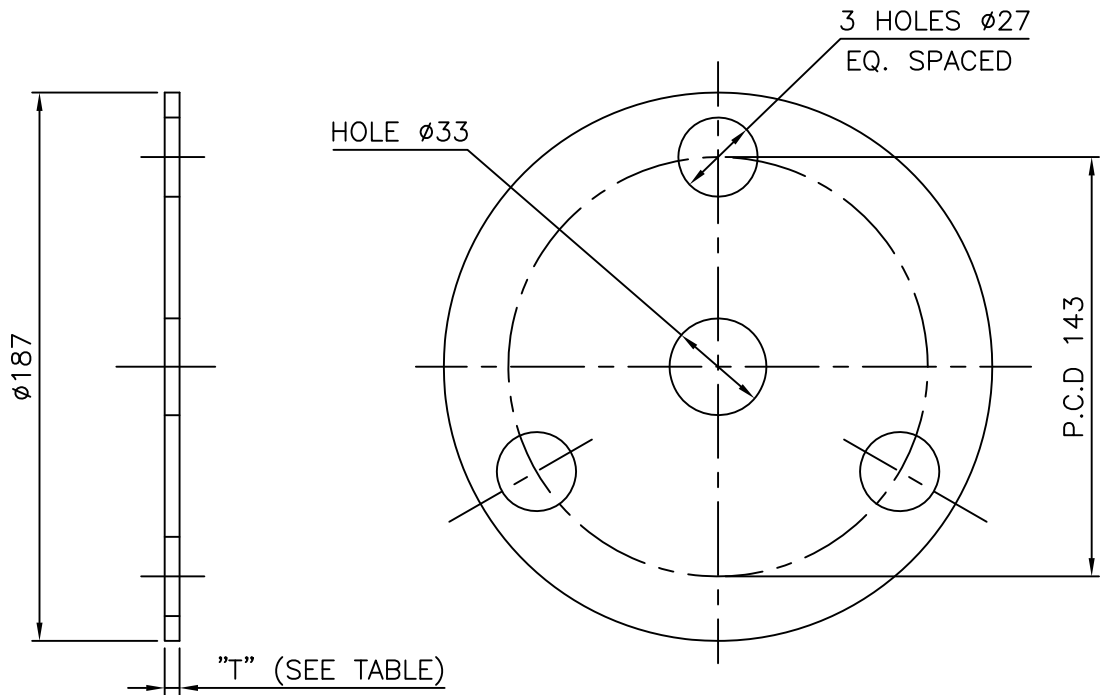

NOTES:-

- 01. SHIMS TO BE MACHINE-CUT AND FREE OF SCALE AND FOREIGN MATTER
 - 02. ALL DIMENSIONS ARE IN MM.
- ONE SET CONSISTS OF ALL VARIANTS AND QTY SHOWN.

STYLE	THICKNESS 'T'	MATERIAL SPEC.	QUANTITY PER SET
01	0.08	AA 10114	2
02	0.12	AA 10114	2
03	0.30	AA 10114	3
04	0.80	AA 10114	2

ITEM NO.	DESCRIPTION	DRAWING NO.	BA9617284260	0.600
			STEEL SHEET	1 SET
ITEM NO.	DESCRIPTION	DRAWING NO.	MATL. CODE	UNIT WT.
			MATL. SPECN.	QTY

REF. DRG. NO.

COMPUTER FILE NAME
46100468.DWG

 BHARAT HEAVY ELECTRICALS LTD. HYDERABAD	NAME	SIGN	DATE	NO.OF VAR.
	DRN. UNIC		14.04.97	
	CHD N.D.SAMUEL	<i>N.D. Samuel</i>	14.04.97	NA
	APPD. S.GHATGE	<i>S. Ghatge</i>	14.04.97	

INVENTORY NO.

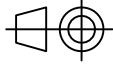
DEPT. BGD	GRADE OF TOL. DIM		SCALE	WEIGHT(K.G.)	REF.TO ASSY.DRG.	ITEM NO.	NO.OF ITEMS
CODE 821	ϕ /M/ ϕ		1:2.5	0.600	1-61-088-01019	11	28

TITLE	CARD CODE	DRAWING NO.	REV.
JOURNAL BRG KEEPER SHIM	U 01	4-61-096-00468	02
		SHEET NO. 01	NO. OF SHEETS 01

THE INFORMATION ON THIS DOCUMENT IS THE PROPERTY OF BHARAT HEAVY ELECTRICALS LIMITED. IT MUST NOT BE USED DIRECTLY OR INDIRECTLY IN ANY WAY DETRIMENTAL TO THE INTEREST OF THE COMPANY.

GENERAL DIMENSIONS, LIMITS, FITS & TOLERANCES AS PER PS HY0230261.

FIRST ANGLE PROJECTION

ALL DIMENSIONS ARE IN mm.

REV	DATE	ALTERED	N.D.S	REV	DATE	ALTERED	N.D.S	REV	DATE	ALTERED	CNY
01	16.6.97	CHECKED	S.G	02	16.1.99	CHECKED	S.G	03	18.5.05	CHECKED	RR
		APPROVED	K.M.R			APPROVED	K.M.R			APPROVED	GK

STY-01 THICKNESS & QTY WAS 0.76&4
 STY-02 THICKNESS & QTY WAS 0.13&4
 STY-03 THICKNESS & QTY WAS 0.3
 STY-04 THICKNESS & QTY WAS 0.542

T IN INCHES DELETED.
 QTY DOUBLED.

MATL STD WAS AA10740

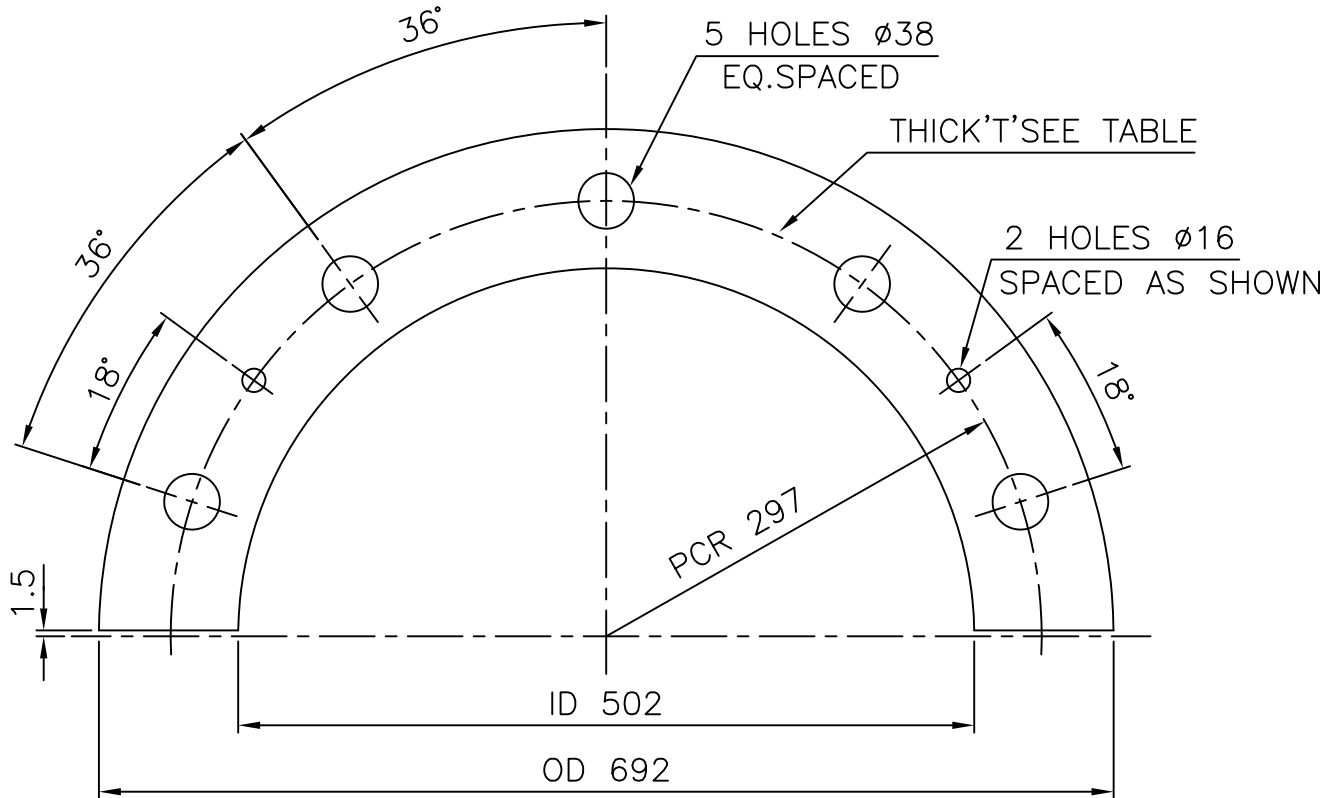

NOTE:— SHIMS TO BE MACHINE-CUT AND FREE OF SCALE AND FOREIGN MATTER
 MATERIAL STANDARD IS:1079

ONE SET CONSISTS OF

STYLE	THICKNESS 'T'	MATERIAL CODE	QUANTITY PER SET
01	0.10		4
02	0.15		4
03	0.45		4
04	2.00		2

SHIM(TO SUIT)		BA9617284294	1.900	
		AA10113		1
DESCRIPTION & DRG.NO.	VAR NO.	RAW MATERIAL SIZE OR CASTING DRG.NO. OR FORGING DRG.NO.	MATL. CODE	NET.WT. GROSS WT
			MATL. SPECN.	QTY.

TYPE OF PRODUCT OR NAME OF CUSTOMER/PROJECT **883 XRP BOWL MILL**

REF. TO HY0230261 FOR UNSPECIFIED TOLERANCES.	BHARAT HEAVY ELECTRICALS LTD. HYDERABAD	DRN.	N.D.S	16.1.99	NO.OF VAR. -NA-
		CKD.	S.G	16.1.99	
		APPD.	K.M.R	16.1.99	
DEPT. PULV.ENGG	SCALE 1:5 WEIGHT(K.G.) 1.900	REF.TO ASSY.DRG.		ITEM NO.	NO.OF ITEM
CODE 446		1.61.088.01019		15	28
TITLE		DRAWING NO.			REV.
JOURNAL BRG HSG SHIM SET		4-61-088-02062			03
		SHT.NO. 01	NO.OF SHT. 01		

COMPUTER NO. 46102062.DWG IT MUST NOT BE USED DIRECTLY OR INDIRECTLY TO THE INTEREST OF THE COMPANY.
 REF. DRG. NO. A-101-00210-3
 SIGN. & DATE
 INVENTORY NO.

FIRST ANGLE PROJECTION

(ALL DIMENSIONS IN mm)

REV. 02	DATE 27.11.03	ALTERED UC	REV.	DATE	ALTERED	ADDITIONAL INFORMATION
		CHECKED G.S.N.M.RAO			CHECKED	STATUS OF DRAWING
		APPROVED			APPROVED	DISTRIBUTION OF PRINTS
DRG. REDRAWN BY INCORPORATING THE PREVIOUS REVISIONS.						

THE INFORMATION ON THIS DOCUMENT IS THE PROPERTY OF BHARAT HEAVY ELECTRICALS LIMITED. IT MUST NOT BE USED DIRECTLY OR INDIRECTLY IN ANY WAY DETRIMENTAL TO THE INTEREST OF THE COMPANY.

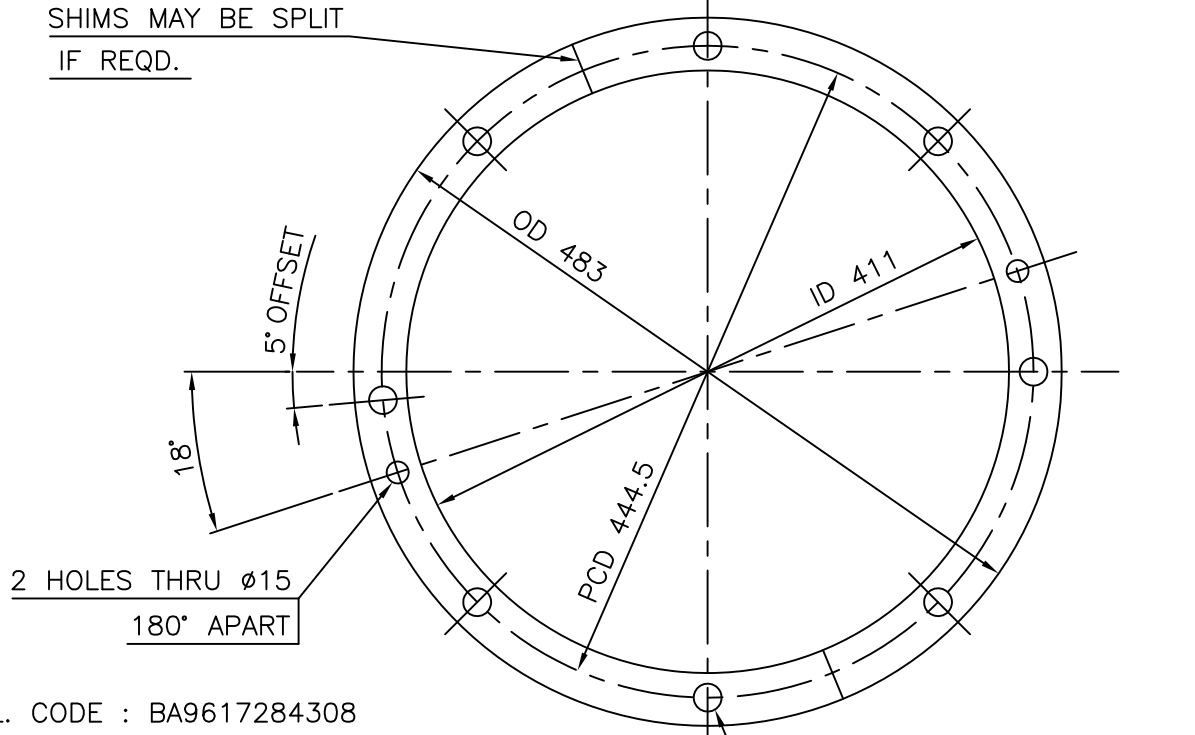

MATL. CODE : BA9617284308

GENERAL DIMENSIONS, LIMITS, FITS & TOLERANCES AS PER PS HY0230261.

8 HOLES Ø19, 7 HOLES EQUI. SPACED ONE HOLE OFFSET BY 5°

04	SH. 0.5		BA9617284308	0.100
			AA10131	1
03	SH. 0.31		BA9617284308	0.060
			AA10131	1
02	SH. 0.13		BA9617284308	0.030
			AA10131	1
01	SH. 0.1		BA9617284308	0.020
			AA10131	1
ITEM NO.	DESCRIPTION	DRAWING NO.	MATL. CODE	UNIT WT.
			MATL. SPECN.	QTY

REF. DRG. NO. (A-101-00993/3)

COMPUTER FILE NAME 46102005.DWG

	BHARAT HEAVY ELECTRICALS LTD.		NAME	SIGN	DATE	NO. OF VAR.
	HYDERABAD		DRN. UNIC		14.04.97	
			CHD G.S.N.M.RAO		27.11.03	
			APPD.			

DEPT. BDG CODE 821	GRADE OF TOL. DIM Ø/M/F		SCALE 1:5	WEIGHT(K.G.) 0.21	REF. TO ASSY. DRG. 1.61.088.01019	ITEM NO. 25	NO. OF ITEMS 28
--------------------	-------------------------	--	-----------	-------------------	-----------------------------------	-------------	-----------------

TITLE	UPPER BEARING KEEPER SHIM SET	CARD CODE	DRAWING NO. 4-61-088-02005	REV. 02
			SHEET NO. 01	NO. OF SHEETS 01



CORPORATE PURCHASING SPECIFICATION

AA10113

Rev No.07

PREFACE SHEET

HOT ROLLED CARBON STEEL SHEET (330 N/mm² Tensile)

FOR INTERNAL USE ONLY

REMOVE THIS PREFACE BEFORE ISSUE TO SUPPLIERS

Comparable Standards:

1. INDIAN : IS: 5986 – 2011, Gr: 205

Suggested/Probable Suppliers and Grades:

Refer plant vendors list

User Plants References:

1. HEEP, HARDWAR : 0500.004, Gr.: St.34
2. HPEP, HYDERABAD : HY0212299
3. HEP, BHOPAL : PS10113
4. HPBP, TRICHY :

Revisions:

As per Cl.No.38.1 of MOM of MRC– S&GPS

APPROVED:

INTERPLANT MATERIAL RATIONALISATION
COMMITTEE – MRC(S&GPS)

Rev No.07

Amd No.

Reaffirmed

Prepared

Issued

Dt. of 1st Issue

Dt:22-02-2014

Dt:

Year:

HEP, Bhopal

Corp.R&D

July, 1976

This page intentionally left blank



CORPORATE PURCHASING SPECIFICATION

AA10113

Rev No. 07

PAGE 1 of 5

HOT ROLLED CARBON STEEL SHEET (330 N/mm² Tensile)

1.0 GENERAL:

This specification governs the quality requirements of Hot Rolled Carbon Steel Sheet of thickness of 2.5 mm to 4.0 mm (both inclusive).

2.0 APPLICATION:

Suitable for cold forming / drawing / fabrication by welding.

3.0 CONDITION OF DELIVERY:

Sheets shall be supplied in hot rolled, decaled and oiled condition. Imported sheets shall be supplied in straight lengths. The edges shall be flattened and sheared. Mill edges are not acceptable. Sheets shall be free from waviness and shall have a uniformly dull (matt) finish.

Oil used for rust prevention should be free from pungent smell. The following oils are suggested:

- a) SERVO RP 125 of M/s. IOC.
- b) RUSTOP 387/388 of M/s. HPC
- c) Bharat TCPF of M/s. Bharat Petroleum
- d) Any other TRP conforming to IS : 1154

4.0 COMPLIANCE WITH NATIONAL STANDARDS:

The material shall comply with the requirements of the following National standards and also meet the requirements of this specification.

IS: 5986 – 2011, Gr.: 205: Hot rolled steel flat products for structural forming and flanging purposes - Specification.

5.0 DIMENSIONS AND TOLERANCES:

5.1 Sizes:

Hot rolled carbon steel sheets shall be supplied to the dimensions in BHEL order.

5.2 Tolerances:

The tolerances on sheets shall comply with the following:

5.2.1 Thickness (IS: 1852):

Thickness, mm	Tolerance, mm
2.50	± 0.20
3.15	± 0.22
4.0	± 0.25

Revisions:
As per Cl.No.38.1 of MOM of MRC– S&GPS

APPROVED:
INTERPLANT MATERIAL RATIONALISATION
COMMITTEE – MRC(S&GPS)

Rev No.07	Amd No.	Reaffirmed	Prepared	Issued	Dt. of 1 st Issue
Dt:22-02-2014	Dt:	Year:	HEP, Bhopal	Corp.R&D	July, 1976

COPYRIGHT AND CONFIDENTIAL
The Information on this document is the property of BHARAT HEAVY ELECTRICALS LIMITED.
It must not be used directly or indirectly in any way detrimental to the Interest of the company.

CORPORATE PURCHASING SPECIFICATION



5.2.2 Width (IS: 1852):

Width, mm	Tolerance, mm
Upto & incld. 1250 mm	+ 6 mm - 0 mm
Over 1250 mm & upto and incld.1550 mm	+ 0.5 percent - 0.0 percent
Over 1550 mm	+ 0.6 percent - 0.0 percent

5.2.3 Length (Continuous mill) IS: 1852:

Length, mm	Tolerance, mm
Upto & incld. 2500 mm	+ 25 mm - 00 mm
Over 2500 mm	+ 1 percent subject to a maximum of 70 mm - 0 percent

5.2.4 Flatness (for cut lengths):

Thickness, mm	Width, mm	Flatness tolerance, mm
From 2.5 to 4.0	Upto & incld. 1200	15
	Over 1200 & upto incld. 1500	20
	Over 1500	25

5.2.5 Edge camber IS: 5986:

The edge camber (i.e. lateral departure of the edge of the material from a straight line forming a chord) of sheets in cut lengths and coil shall not exceed the following values:

5.2.5.1 For Cut Lengths:

Length in meters		Tolerance, mm
Over	Upto & incld.	
--	1.25	5
1.25	1.80	6
1.80	2.50	8
2.50	3.15	10
3.15	3.55	12
3.55	4.00	16
4.00	5.00	19

5.2.5.2 For Coils:

25 mm in any 5000 mm length.



CORPORATE PURCHASING SPECIFICATION

AA10113

Rev No.07

PAGE 3 of 5

6.0 MANUFACTURE:

Process of manufacture is left to the discretion of the manufacturer except Bessemer process.

Material shall be manufactured from semi killed or killed steel.

7.0 FREEDON FROM DEFECTS:

The sheets shall be free from harmful defects, twists, buckle, rust, scale and waviness and shall be reasonably smooth, flat and square.

8.0 CHEMICAL COMPOSITION:

The melt analysis of steel and the permissible variation in the composition of the material from the melt analysis shall be as follows:

Element	Melt analysis, percent, max.	Permissible variation, percent, max.
Carbon	0.15	0.03
Manganese	0.80	0.05
Sulphur	0.040	0.005
Phosphorus	0.040	0.005

9.0 TEST SAMPLES:

9.1 Tensile Test:

One sample shall be taken per thickness per consignment from each melt.

As far as possible test pieces shall be cut transverse to the direction of rolling and shall be of full thickness of the sheet rolled.

9.2 Bend Test:

One sample shall be taken per thickness per consignment from each melt.

Bend test pieces shall be cut so that the axis of the bend is parallel to the direction of rolling viz. transverse.

Note: When more than one thickness is rolled from the same melt, one additional test piece for each thickness shall be taken.

10.0 MECHANICAL PROPERTIES:

10.1 Bend:

When tested in accordance with IS: 1599, the test pieces shall be capable of being bent cold through 180° close. The outer convex surface of the test piece shall be free from cracks.

10.2 Tensile:

When tested as per IS: 1608, the test pieces shall show the following properties:

CORPORATE PURCHASING SPECIFICATION



Tensile strength	: 330 – 440 N/mm ²
Yield strength	: 205 N/mm ² , min.
Elongation:	
For sheets up to & Incl. 3 mm, thick	: 20 %, minimum on 80 mm gauge length
For sheets above 3 mm, thick	: 28 %, minimum in 5.65 √So gauge length

11.0 HARDNESS (VICKERS):

When tested in accordance with IS: 1501, the material shall show a Vickers hardness in the range of 100 – 140 HV.

Note: Hardness test shall be conducted only when tensile test cannot be performed.

12.0 TEST CERTIFICATES:

Unless otherwise specified, three copies of test certificates shall be supplied.

In addition, the supplier shall ensure to enclose one copy of the test certificate along with their dispatch documents to facilitate quick clearance of the material.

The test certificate shall bear the following information:

AA10113, Rev 07: HOT ROLLED CARBON STEEL SHEET (330 N/mm² Tensile)

BHEL Order No,

Supplier's name,

Identification No

Melt No,

Process of manufacture

Details of pickling, descaling and oiling

Results of dimensional inspection

Results of Chemical analysis and Mechanical tests,

Note: Material procured, supplied and certified as AA10113 / IS: 5986, Gr.:205 and comply with the requirements of this specification is acceptable.

13.0 PACKING AND MARKING:

Steel sheets shall be supplied in bundles and shall be suitably packed in bundles to prevent corrosion and damage during transit.

The recommended packing for imported material shall be as shown below.

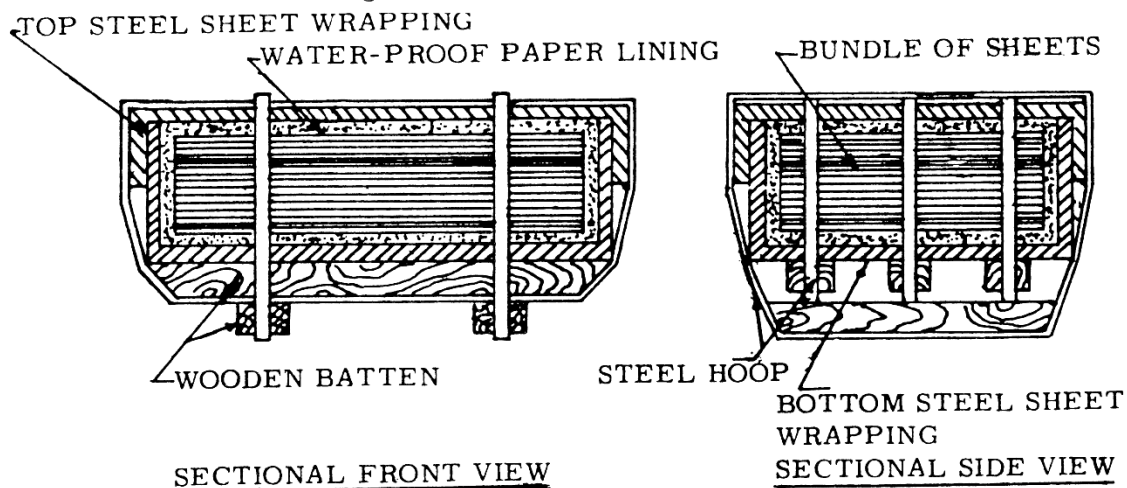



CORPORATE PURCHASING SPECIFICATION

AA10113

Rev No.07

PAGE 3 of 5

Note:

- a) Water proof paper lining shall be preferably Volatile Corrosion Inhibitor (V.C.I.) Coated Paper with an additional polythene (100 micron) enveloped.
- b) Approximate weight of each bundle shall be 2 to 3 tonnes. Bundle weighing 2 metric tonnes is however preferred.

A metal label shall be securely attached to each bundle and shall bear the following information:

AA10113:HOT ROLLED CARBON STEEL SHEET (330 N/mm² Tensile)

BHEL Order No,

Supplier's Name & Identification No,

Size & Thickness of sheets

Weight

14.0 REFERRED STANDARDS (Latest publications including amendments):

- 1) IS: 1154 2) IS: 1501 3) IS: 1852 4) IS: 1599 5) IS: 1608

**CORPORATE PURCHASING SPECIFICATION**

AA 101 14

Rev. No. 07

PREFACE SHEET

COLD ROLLED CARBON STEEL SHEET-ORDINARY

FOR INTERNAL USE ONLY
REMOVE THIS PREFACE SHEET BEFORE ISSUE TO SUPPLIERS

Comparable Standards:

1. INDIAN : IS: 513-1994
Gr: O-Ordinary
Quality : Killed/Semi Killed
Temper : No 4-Annealed & skin passed
Surface finish : Matt
Surface type : Best

Suggested/Probable Suppliers And Grades:

1. M/s SAIL : IS : 513, Gr.: O

User Plant References:

1. BHOPAL : --
2. HEER, HARDWAR : --
3. HYDERABAD : HY 021 02 99
4. TIRUCHY : BM-C 07

Revisions :

Cl: 27.6.7 of MOM of MRC-S&GPS

APPROVED :**INTERPLANT MATERIAL RATIONALISATION
COMMITTEE-MRC (S&GPS)**

Rev. No. 07

Amd.No.

Reaffirmed

Prepared

Issued

Dt. of 1st Issue

Dt: 15.06.2005

Dt :

Year :

BHOPAL

Corp. R&D

JULY, 1976

**CORPORATE PURCHASING SPECIFICATION**

AA 101 14

Rev. No. 07

PAGE 1 OF 6

COLD ROLLED CARBON STEEL SHEET – ORDINARY**1.0 GENERAL:**

This specification governs the quality requirements of Cold Rolled Carbon Steel Sheet of ordinary quality, Annealed and skin passed condition. Sheets having thickness of 0.40 to 2.50 mm (both inclusive) are covered in this specification.

2.0 APPLICATION:

Suitable for general purpose.

3.0 CONDITION OF DELIVERY:

Cold rolled descaled and oiled sheets/coils shall be supplied in fully annealed and skin passed condition. The size, weight and packing of the coils/sheets shall be as agreed to between the manufacturer and BHEL for indigenous material. For imported material, it shall comply with clause 14.0.

Sheets shall be supplied in straight lengths or in coils as specified in BHEL order.

Sheets shall be flat and the edges cleanly sheared and truly squared to the specified dimensions.

Oils used for rust prevention shall be free from pungent smell. The following oils are suggested :

- a) SERVO RP 125 of M/s. IOC.
- b) RUSTOP 387/388 of M/s. HPC
- c) Bharat TCPF of M/s. Bharat Petroleum
- d) Any other TRP conforming to IS : 1154

4.0 COMPLIANCE WITH NATIONAL STANDARDS:

The material shall comply with the requirements of the following national standards and also meet the requirements of this specification.

IS: 513-1994, Gr: O-ordinary

Temper: No 4, Annealed & Skin passed;

Quality: killed/semi killed

Surface type - Best;

Surface finish : Matt.

Revisions :**Cl. 27.6.7 OF MOM OF MRC-S&GPS****APPROVED :****INTERPLANT MATERIAL RATIONALISATION
COMMITTEE-MRC (S&GPS)****Rev. No. 07****Amd.No.****Reaffirmed****Prepared****Issued****Dt. of 1st Issue****Dt.:15.06.2005****Dt :****Year :****BHOPAL****Corp. R&D****JULY, 1976**



5.0 DIMENSIONS AND TOLERANCES:

5.1 Sizes:

Cold rolled carbon steel sheets shall be supplied to the dimensions specified in BHEL order.

5.2 Tolerances:

The tolerances on sheets shall comply with IS : 513 as detailed below:

5.2.1 Thickness:

Shall comply with table 6 of IS:513.

5.2.2 Width:

<u>Width</u>	<u>Tolerance</u>
Upto and incld. 1250 mm	+ 7 mm - 0 mm
Above 1250 mm	+ 10 mm - 0 mm

5.2.3 Length:

<u>Width</u>	<u>Tolerance</u>
Up to and incld. 2000 mm	+ 15 mm - 0 mm
Over 2000 mm	+ 0.75 percent of length - 0 percent

5.2.4 Edge Camber:

The edge camber (ie. Lateral departure of the edge of the material from a straight line forming a chord) of sheets in cut lengths/coils shall not exceed 0.4 percent X length.

5.2.5 Out of Square Tolerances (for cut lengths) :

1 % (percent) of the width.

(Out of squareness is the deviation of an edge from a straight line drawn at a right angle to the other edge of the sheet, touching one corner and extending to the opposite edge).

6.0 MANUFACTURE :

Steel shall be manufactured by open-hearth, electric, basic oxygen or a combination of these processes.

Material shall be manufactured from semi – killed or killed steel.

Rimmed steel is not acceptable.

7.0 FINISH:

Material shall have a medium or dull finish. Pores, roll marks or scratches which do not impair uniform appearance of the finished product are permissible. The sheets shall be free from waviness and the surface shall be ideal for spray painting.

**8.0 HEAT TREATMENT :**

Sheets shall be fully annealed and skin passed.

9.0 FREEDOM FROM DEFECTS :

The material shall be free from harmful defects such as scale, rust, blisters, laminations, pitting, cracked edges, etc.

10.0 CHEMICAL COMPOSITION :

The melt analysis of steel and the permissible variation in the composition of the material from the melt analysis shall be as follows:

Element	Melt analysis, percent, max	Permissible variation, percent, max.
Carbon	0.15	0.02
Manganese	0.60	0.03
Sulphur	0.055	0.005
Phosphorus	0.055	0.005

11.0 TEST SAMPLES:

One bend test and hardness test shall be carried out from each melt and heat treatment batch of each size.

Test pieces shall be cut so that the axis of the bend is parallel to the direction of rolling, viz., transverse direction.

12.0 MECHANICAL PROPERTIES :**12.1 Bend Test :**

The test piece shall be capable of being bent cold through 1 t (t = thickness) without showing sign of cracks or fracture on the outer convex surface.

Bend test shall be carried out in accordance with IS : 1599.

12.2 Hardness (Vickers) :

When tested as per IS : 1501, the test pieces shall show a Vickers hardness of 120 HV, max..

12.3 Tensile Strength (for information only):

275 N/mm² for design purpose.



13.0 TEST CERTIFICATES:

Unless otherwise specified, three copies of test certificates shall be supplied.

In addition, the supplier shall ensure to enclose one copy of the test certificate along with their dispatch documents to facilitate quick clearance of the material.

The test certificate shall bear the following information:

AA 101 14, Rev 07: Cold rolled carbon steel sheet-ordinary

BHEL Order No,

Melt No,

Process of manufacture

Supplier's name,

Identification No

Details of oiling and heat treatment

Dimensional inspection

Results of Chemical analysis and Mechanical tests

Note: Material procured, supplied and certified as AA 101 14, Rev 07/IS:513, Gr.: O-ordinary from M/S SAIL and comply with the requirements of this specification is acceptable.

14.0 PACKING AND MARKING:

14.1 Packing:

Sheets and Coils shall be suitably packed in bundles to prevent corrosion and damage during transit.

Recommended packing for imported material shall be as shown below. However, other methods of packing is also acceptable if prior agreement of BHEL is obtained in writing by the manufacturer.

14.1.1 Sheets :

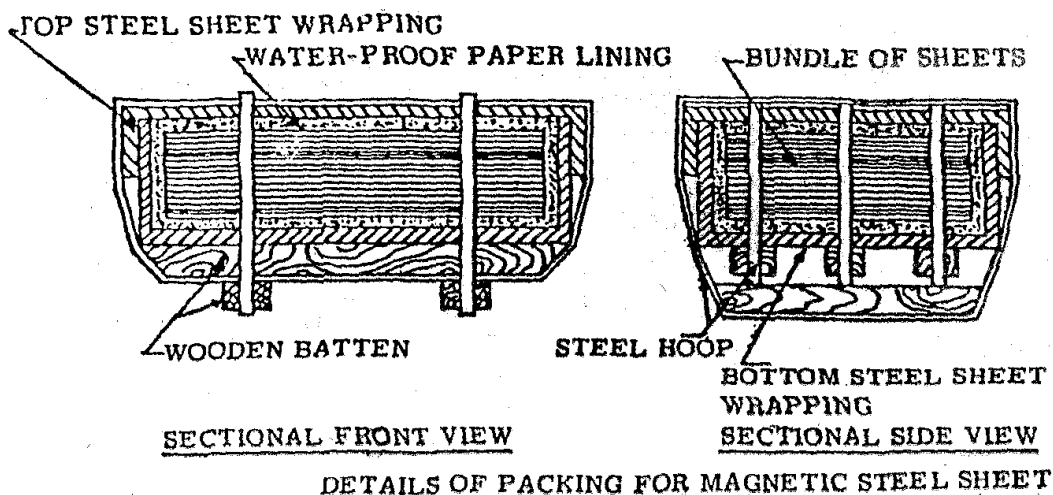

Note:

- Water proof paper lining shall be preferably Volatile Corrosion Inhibitor (V.C.I.) Coated Paper with an additional polythene (100 micron) enveloped.
- Approximate weight of each bundle shall be 2 to 3 tonnes. Bundle weighing 2 metric tonnes is however preferred.



14.1.2 Coils:

The material shall be supplied in coils of continuous strip. The nominal weight of each coil shall be 1800 - 2000 kg.

The nominal internal diameter of coil shall be 500 mm.

Sheet shall be protected to prevent damage and rusting during transit.

Sheet shall be vertically packed according to the instructions and drawings given below:

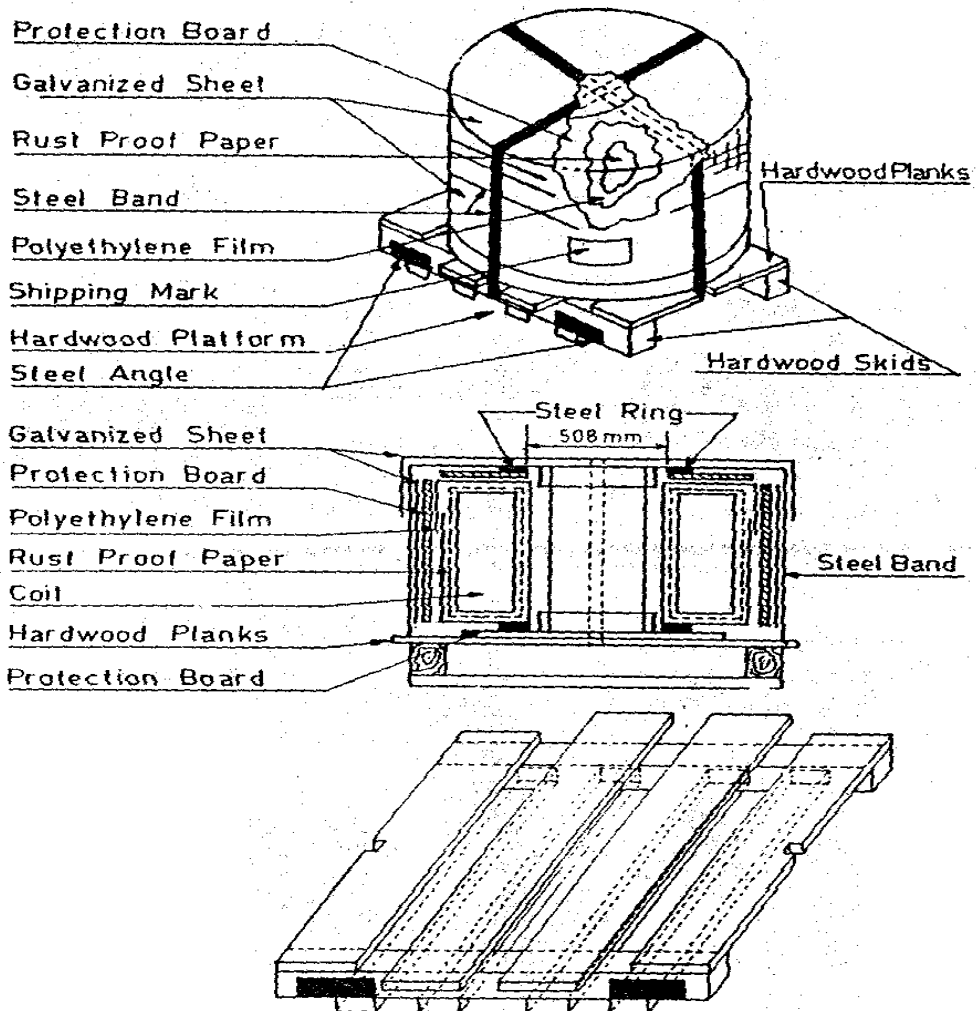



- a) An annular protection board shall be placed at either end of the coil.
- b) The coil should then be wrapped with waterproof anti-rust proof paper by lapping axially all around the circumference.
- c) The coil shall then be covered by polythylene sheet or anti-rust waterproof paper and the ends sealed properly.
- d) A galvanized sheet shall be wrapped on the outside of the coil and the top and bottom of the coils. Care shall be taken to ensure that the ends of the top and bottom of the coils extend sufficiently over the inside diameter of the coil.
- e) A galvanized sheet shall be wrapped on the inside of the coil. Care shall be taken that it overlaps sufficiently over the ends of the sheet mentioned in (d) above.
- f) Steel ring made from thick angle sheets shall be placed on the rim of the inner diameter at both ends of the coil. The rings shall be held at either ends at four points by steel bands.
- g) The coil should then be mounted on wooden skids held together by steel bands. Wooden skids must have cutouts to house the steel bands for tight fit and to avoid slippage.
- h) The packing shall ensure that there is no seepage of moisture and the coils reach BHEL in completely rust free condition. It shall be strong enough to withstand handling.
- i) Coils shall be sufficiently tight-wound to prevent collapse to an extent that would preclude their being mounted on a mandrel appropriate to the ordered internal diameter.
- j) Each package should indicate the , Sling Position, for lifting without damage. It is preferable to fix a suitable size of, 'Sheet Steel Angle', at the position where the Sling Rope is to be fitted to avoid slippage/damage/breakage of the wooden skid at four places.

14.2 MARKING:

A metal label shall be securely attached to each bundle and shall bear the following information :

AA 101 14 : Cold rolled carbon steel sheet-ordinary

BHEL Order No,

Supplier's Name & Identification No,

Melt No, Size & Thickness of sheet,

Bundle No., Weight.

15.0 REFERRED STANDARDS (Latest Publications Including Amendments) :

1. IS : 513

2. IS : 1154

3. IS : 1501

4. IS : 1599

TD-106-1

Rev.5

Form No.



PRODUCT STANDARD

PULVERISERS
HYDERABAD

PRODUCT
STD No. BA55016

Rev. No. 01

PAGE 01 OF 02

SHIMS FOR JOURNAL HOUSING

MATERIAL CODE : SEE TABLE

MATERIAL : AS PER IS:1079 & IS:1993

TOLERANCE : AS PER IS 1852

NOTE:

- SURFACE MUST BE FLAT, TRUE & PARALLEL
- MACHINE OUT AND FREE FROM FOREIGN MATTERS
(ALL EDGES TO BE SMOOTH)
- ALL DIMENSIONS ARE IN mm
- ONE SET CONSISTS OF FOLLOWING THICKNESS
ONE NO IN EACH THICKNESS.

THICKNESS SIZES : 0.10, 0.15, 0.20, 0.30, 0.40, 0.50, 1.00, 1.60 & 1.80

PACKING : ALL THE SHIMS TO BE TIED AS A SET

MARKING : A TAG WITH SPECTION & VAR NO.

BOWL MILL : 583, 603 XRS, 623,603 XRP
763, 783, 803 XRP

LOCATION : JOURNAL ASSY,60-358,60-360,61-362,61-360, 61376, 61-378 & 61-380

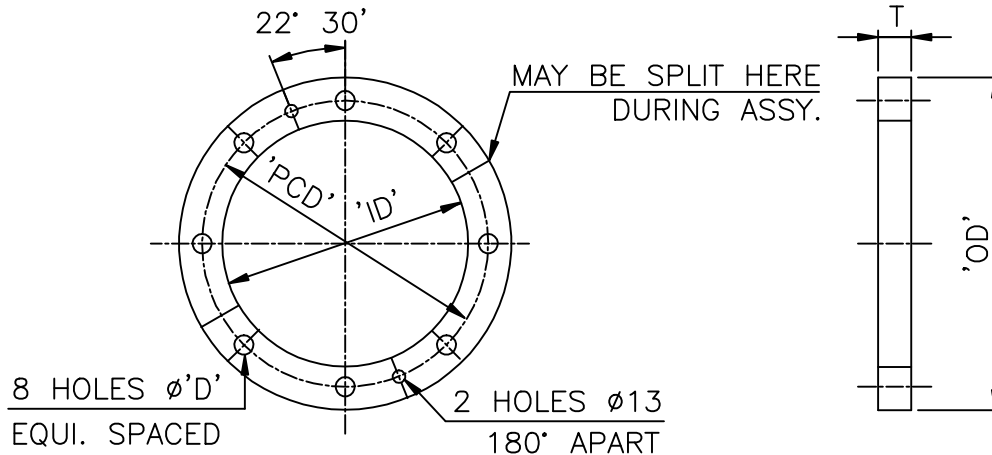

TABLE

MILL TYPE	VAR No.	'OD'	'ID'	'PCD'	ø'D'	MAT.CODE
803	01	559	436	489	40	BA9755016007
623	02	419	308	365	30	BA9755016015

FOR REVISIONS REFER RECORD OF REVISIONS

PREPARED

APPROVED

DATE

B M R

RAMANNA

2000.03.20

COPYRIGHT AND CONFIDENTIAL

The information on this document is the property of BHARAT HEAVY ELECTRICALS LIMITED. It must not be used directly or indirectly in any way detrimental to the interest of the company.

COMP. FILE NAME

BA55016.DWG

Ref. Doc.

A-654 & A-612

TD-106-1

Rev.5

Form No.



PRODUCT STANDARD

PULVERISERS
HYDERABAD

Spec.NO: BA55020

Rev. No. 01

PAGE 01 OF 02

SHIMS FOR PUMP HOUSING COVER

MATERIAL CODE : BA9755020012
LOCATION : MILL DRIVE ASSY OF 763/783/803 XRP
MATERIAL : AS PER IS:1079 & IS:1993
TOLERANCE : AS IS 1852

NOTE:

- SURFACE MUST BE FLAT, TRUE & PARALLEL
- MACHINE CUT AND FREE FROM FOREIGN MATTERS
(ALL EDGES TO BE SMOOTH)
- ALL DIMENSIONS ARE IN mm
- ONE SET CONSISTS OF FOLLOWING THICKNESS
ONE NO IN EACH THICKNESS.

THICKNESS SIZES : 0.10, 0.15, 0.3, 0.4, 0.5, 1.0 & 1.6

PACKING : ALL THE SHIMS TO TIED AS A SET

MARKING : A TAG WITH SPECTION & VAR NO.

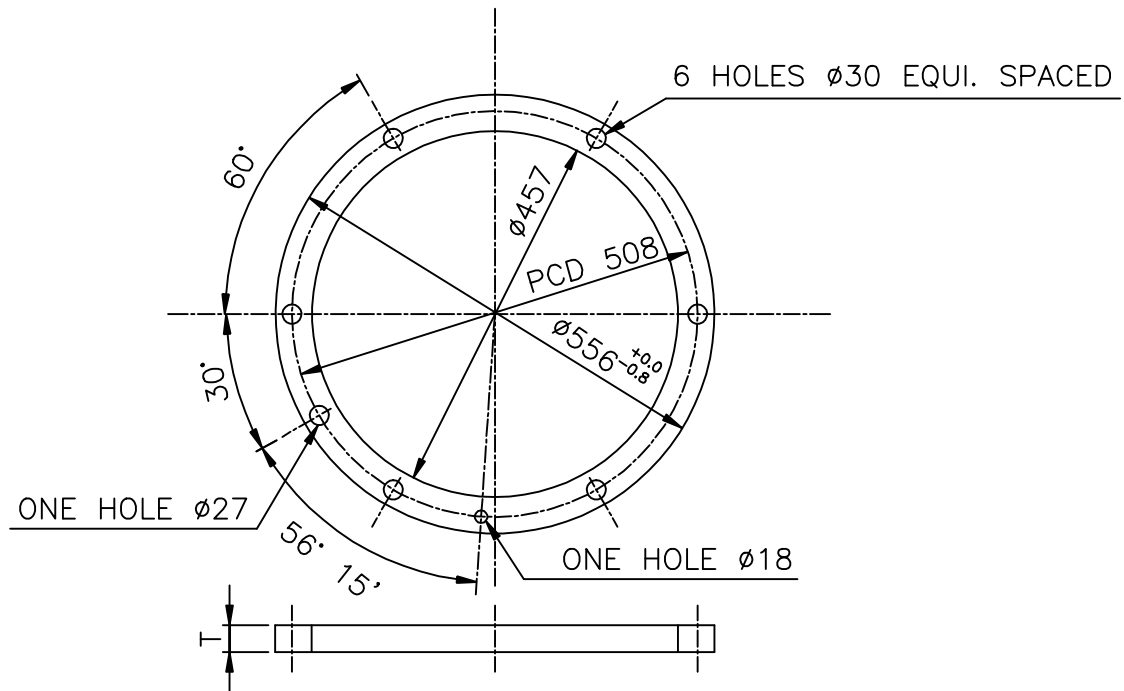

COPYRIGHT AND CONFIDENTIAL

The information on this document is the property of BHARAT HEAVY ELECTRICALS LIMITED.
It must not be used directly or indirectly in any way detrimental to the interest of the company.

COMP. FILE NAME

BA55020.DWG

Ref. Doc.

A-608

FOR REVISIONS REFER RECORD OF REVISIONS

PREPARED

B M R

APPROVED

RAMANNA

DATE

2000.03.20

TD-106-1

Rev.5

Form No.



PRODUCT STANDARD

PULVERISERS
HYDERABAD

Spec.NO: BA55019

Rev. No. 02

PAGE 01 OF 02

SHIMS FOR W.SHAFT THRUST BRG. HSG.COVER

MATERIAL CODE : BA9755019014
LOCATION : MILL DRIVE ASSY OF 763/783/803 XRP MILLS
MATERIAL : AS PER IS 1079 & IS 1993
TOLERANCE : AS PER IS 1852

NOTE:

- SURFACE MUST BE FLAT, TRUE & PARALLEL
- MACHINE CUT AND FREE FROM FOREIGN MATTERS
(ALL EDGES TO BE SMOOTH)
- ALL DIMENSIONS ARE IN mm
- ONE SET CONSISTS OF FOLLOWING THICKNESS
ONE PAIR IN EACH THICKNESS.

THICKNESS SIZES : 0.10, 0.15, 0.20, 0.30, & 0.40

PACKING : ALL THE SHIMS TO BE TIED AS A SET

MARKING : A TAG WITH SPECTION & VAR NO.

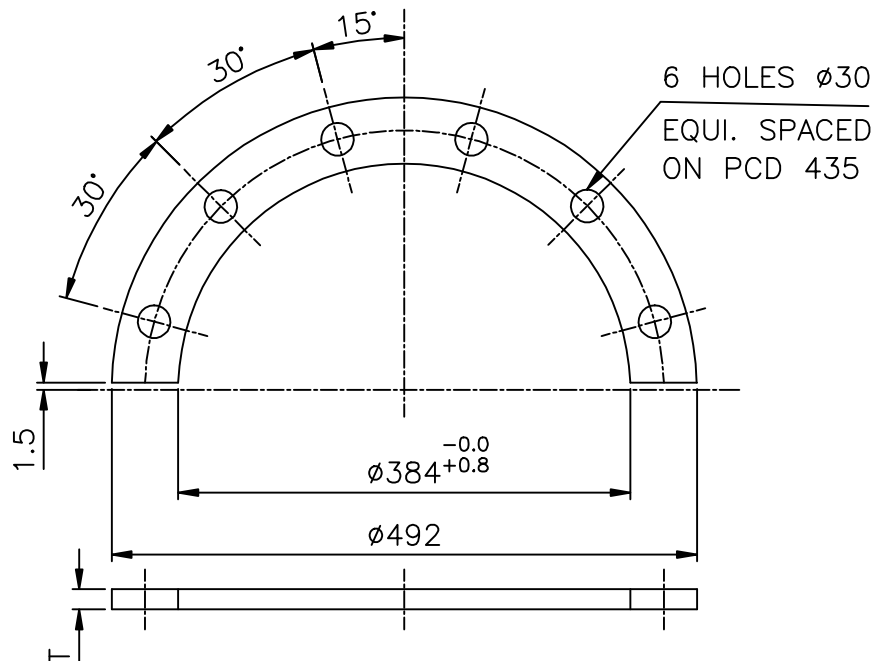

COPYRIGHT AND CONFIDENTIAL

The information on this document is the property of BHARAT HEAVY ELECTRICALS LIMITED.
It must not be used directly or indirectly in any way detrimental to the interest of the company.

COMP. FILE NAME

BA55019.DWG

Ref. Doc.

A-609

FOR REVISIONS REFER RECORD OF REVISIONS

PREPARED

B M R

APPROVED

RAMANNA

DATE

2000.03.20

TD-106-1

Rev.5

Form No.



PRODUCT STANDARD

PULVERISERS

HYDERABAD

Spec.NO: BA55017

Rev. No. 01

PAGE 01 OF 02

SHIMS

MATERIAL CODE : REF. TABLE
LOCATION : REF. TABLE
MATERIAL : AS PER IS 1079 & IS 1993
TOLERANCE : AS PER IS 1852

NOTE:

- SURFACE MUST BE FLAT, TRUE & PARALLEL
- MACHINE CUT AND FREE FROM FOREIGN MATTERS
(ALL EDGES TO BE SMOOTH)
- ALL DIMENSIONS ARE IN mm
- ONE SET CONSISTS OF FOLLOWING THICKNESS
ONE NO IN EACH THICKNESS.

THICKNESS SIZES : 0.10, 0.15, 0.20, 0.30, 0.40, 0.50, 1.00 & 1.8

PACKING : ALL THE SHIMS TO BE TIED AS A SET

MARKING : A TAG WITH SPECTION & VAR NO.

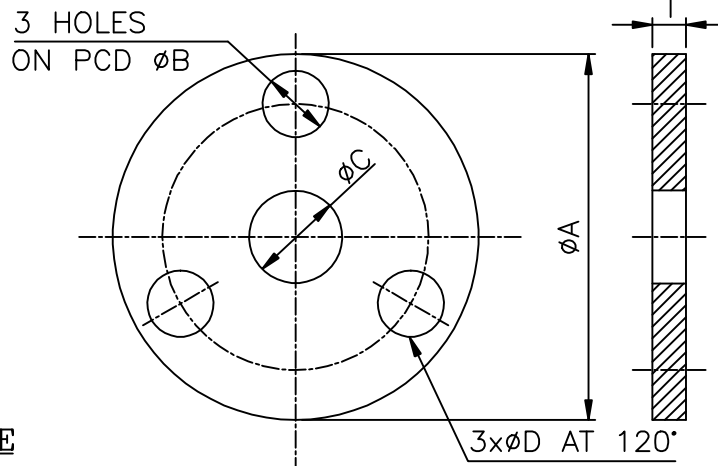

TABLE

MILL TYPE	VAR NO.	ϕA	ϕB	ϕC	ϕD	LOCATION	MAT.CODE
803 XRP	01	140.0	102.0	48	25	OIL PUMP KEEPER	BA9755017011
803 XRP	02	162.0	114.5	32	25	JRN.L.BRG KEEPER	BA9755017020
603 XRP	03	95.0	70.0	48	16	OIL PUMP KEEPER	BA9755017038
603 XRP	04	124.0	90	32	25	JRN.L.BRG KEEPER	BA9755017046

FOR REVISIONS REFER RECORD OF REVISIONS

PREPARED

APPROVED

DATE

B M R

RAMANNA

2000.03.20

COPYRIGHT AND CONFIDENTIAL

The information on this document is the property of BHARAT HEAVY ELECTRICALS LIMITED. It must not be used directly or indirectly in any way detrimental to the interest of the company.

COMP. FILE NAME

BA55017.DWG

Ref. Doc.

A607,613
651 & 653

