



BHARAT HEAVY ELECTRICALS LIMITED
(A Govt. Of India Undertaking)
POWER SECTOR, EASTERN REGION
BHEL BHAWAN, PLOT NO. DJ-9/1 , SECTOR II ,
SALT LAKE CITY, KOLKATA, WEST BENGAL, INDIA
Phone : 033-23216130-31,033-23216130 FAX : 033-23211960

NOTICE INVITING TENDER (NIT)

OFFERS are invited from **REPUTED AND EXPERIENCED LOCAL BIDDERS** (meeting pre-qualification criteria as mentioned) **through E-PROCUREMENT PORTAL <https://eprocurebhel.co.in> ONLY** for the subject job by the undersigned on behalf of BHARAT HEAVY ELECTRICALS LIMITED as per the tender document.

ISSUE OF TENDER TO ANY BIDDER SHALL NOT CONSTRUCT THAT THE BIDDER IS CONSIDERED TO BE QUALIFIED. FOLLOWING POINTS RELEVANT TO THE TENDER MAY PLEASE BE NOTED AND COMPLIED WITH:

Salient Features of NIT

SL NO	ISSUE	DESCRIPTION	
i	E-TENDER NUMBER	PSER:PUR:TSX:180(I):083 (ENQ:23:PP:0015:PUR:80) DATE: 04/01/2024	
ii	Broad Scope of job	SUPPLY AND COMMISSIONING OF FLUE GAS ANALYZER, SPECTROPHOTOMETER AND PRESSURE TRANSMITTERS & DIFFERENTIAL PRESSURE TRANSMITTERS FOR BHEL PSER - HQ KOLKATA.	
iii	DETAILS OF TENDER DOCUMENT		
a)	PART – B	GENERAL CONDITIONS OF CONTRACT (GCC)	Applicable
b)	PART – C	TECHNICAL SCOPE AND SPECIAL TERMS AND CONDITIONS (SCC)	Applicable
c)	PART – F	GENERAL TERMS & CONDITIONS OF REVERSE AUCTION	Applicable
d)	PART – E	PRICE SCHEDULE and UNPRICE SCHEDULE (ABSOLUTE VALUE)	Applicable
e)	PART – H	FORMS AND PROCEDURES ETC.	Applicable
iv	ISSUE OF TENDER DOCUMENTS	a)Online through e-procurement platform at https://eprocurebhel.co.in/ b)in BHEL website (www.bhel.com, CPP Portal): For tender view purpose only. START DATE: 04/01/2024	a) Applicable b) Applicable
v	DUE DATE & TIME OF OFFER SUBMISSION	Date: 15/01/2024, Time: 14-00 Hrs. (Offer to be submitted online only through e-procurement platform at https://eprocurebhel.co.in/)	Applicable
vi	TECHNO-COMMERCIAL BID OPENING OF TENDER	Date: 15/01/2024, Time: 16-30 Hrs. (online only through e-procurement platform at https://eprocurebhel.co.in/, participating bidders may witness the same online only)	Applicable
vii	CURRENCY	INDIAN RUPEES (INR)	Applicable
viii	EMD AMOUNT	Rs. 1,00,000 (Rupees One Lakh Only)	Applicable
ix	COST OF TENDER	-	Not Applicable
x	LAST DATE FOR SEEKING CLARIFICATION	Date: 12/01/2024 (UP TO 12:00 Hrs.)	Applicable
xi	SCHEDULE OF Pre Bid Discussion (PBD)	Not Applicable (In case BHEL decides to conduct PBD, date, time & venue of PBD will be intimated suitably thru TCN).	Not Applicable
xii	INTEGRITY PACT & DETAILS OF INDEPENDENT EXTERNAL MONITOR (IEM)	Not Applicable	Not Applicable
xiii	Latest updates	Latest updates on the important dates, Amendments, Correspondences, Corrigenda, Clarifications, Changes, Errata, Modifications, Revisions, etc to Tender Specifications will be hosted in BHEL webpage (www.bhel.com →Tender Notifications →View Corrigendums & CPP portal →Tender Notice & E-PROCUREMENT PORTAL https://eprocurebhel.co.in) and not in the newspapers. Bidders to keep themselves updated with all such information.	Shall be intimated to bidder

पावर सेक्टर पूर्वी क्षेत्र (मुख्यालय)

POWER SECTOR EASTERN REGION, DJ-9/1, SALT LAKE CITY, KOLKATA - 700 091

फैक्स/Fax: (033) 23211960 फोन/Phone: बोर्ड/EPABX: 23398220

Page - 1 of 37

1. The offer shall be submitted as per the instructions of tender document. Only One set of tender document (**in original, downloaded from website**) signed by authorised company rep. of bidder and stamped on each page shall be submitted as detailed further, as given below. Bidders to note specifically that all pages of tender document, including these NIT pages etc. appearing in the website for this particular tender shall be submitted by them (after signing/stamping on each page) as a part of their offer. **Price shall not be mentioned by them anywhere in the techno-commercial portion of offer. Price shall be mentioned in the relevant price schedule only and to be submitted in e-procurement portal/platform in the form and manner mentioned in tender.**

For E-Procurement Assistance & Training, NIC PORTAL Helpdesk Contacts as per following: -

For any technical related queries please call at 24x7 Help Desk Number
0120-4001 002, 0120-4200 462, 0120-4001 005, 0120-6277 787

Email Support

Address: A) For any Issues or Clarifications relating to the published tenders, bidders are requested to contact the respective Tender Inviting Authority

Technical - support-eproc@nic.in

For any difficulty in downloading the tender from internet website, they should contact this office (Dy. Manager, Purchase or SDGM, Purchase Phone no. 033-23398222/8221/8220). No alteration/changes by bidders is permitted in the tender/NIT appeared in the website.

2. Successful bidder shall have to submit additional set of tender/sign on tender document provided by BHEL, if so decided by BHEL.
3. This is an e-tender floated online through our E-Procurement Site <https://eprocurebhel.co.in>. The bidder should respond by submitting their offer online only in our e-Procurement platform at <https://eprocurebhel.co.in>. Offers are invited in two-parts only. No Hard copy bid or bids through email/ fax shall be accepted. Bids are invited in two parts & shall be submitted as described below:

OFFER DESCRIPTION	DOCUMENTS TO BE UPLOADED & MODALITY OF UPLOADING
TECHNICAL OFFER	1. Scanned copy of Covering letter of offer (To be attached in Attachment section) 2. Scanned copy of Entire tender documents signed & stamped in each page by authorized representative of the bidder except price bid (To be attached in Attachment section). 3. Scanned copy of Techno-Commercial Offer (To be attached in Attachment section) 4. Duly filled all annexures except price & unpriced format (To be attached in Attachment section). 5. Copy of records notes of Pre-Bid Conference, if applicable/ pre-bid MOM. (To be attached in Attachment section) 6. Copy of Tender change notice (TCN), if applicable (To be attached in Attachment section) 7. All supporting documents/ Annexures etc. as applicable (To be attached in Attachment section). 8. No deviation certificate in bidder's letterhead as per format given in Tender (To be attached in Attachment section).
PRE-QUALIFICATION PART	9. Pre-qualifying documents with all credentials as per tender. (To be attached in PQ Attachment section)
UNPRICED PRICE BID	10. Price schedule –Unpriced but mentioning only quoted / unquoted against each item as per tender.
PRICE BID	11. Duly filled in Price Schedule as per tender. Any other document uploaded in the price bid, apart from tendered Price schedule, shall not be taken into cognizance for evaluation of offer.

4. **EARNEST MONEY DEPOSIT (EMD) of Rs. 1,00,000 (Rupees One Lakh Only)**, in the form & manner prescribed in tender, shall be submitted by bidder as mentioned below, failing which the bidder's offer is liable for rejection.

4.1 Every tender must be accompanied by the prescribed amount of Earnest Money Deposit in any one of the following forms:

- a) **Cash deposit as permissible under the extant Income Tax Act** (Before tender opening) - The amount should be remitted by the party to the Cashier of Bharat Heavy Electricals Limited, PS-ER, Kolkata between 14.00 hours and 16.00 hours on working days and cash receipt issued by him shall be enclosed along with the tender.
- b) **Electronic Fund Transfer** credited in Bharat Heavy Electricals Limited, PS-ER's account (before tender opening). RTGS details of BHEL-PSER is available in tender.

- c) **Banker's Cheque/Pay Order/Demand Draft** payable at Kolkata duly pledged in favour of Bharat Heavy Electricals Limited, Kolkata (along with offer).

d) Any other mode as per latest guidelines issued by Govt. of India.

In case total EMD amount is more than INR 20 LAKH, the amount in excess of INR 20 LAKH may be accepted in the form of Bank Guarantee from scheduled bank. The bank Guarantee in such cases shall be valid at least for six months.

- 4.2 Tenders received without Earnest Money in full in the manner prescribed above are liable to be rejected.
- 4.3 EMD given by all unsuccessful tenderers shall be refunded on acceptance of award/LOI/PO by successful tenderer. The EMD of the successful bidder shall be returned after submission of Security Deposit BG (SDBG).
- 4.4 EMD shall not carry any interest.
- 4.5 BHEL reserves the right of forfeiture of Earnest Money Deposit submitted by the tenderer if: -
EMD by the tenderer shall be forfeited as per tender documents if -
- After opening the tender and within the offer validity period, the tenderer revokes his tender or makes any modification in his tender which is not acceptable to BHEL.
 - The contractor fails to deposit the required Security Deposit or commence the work within the period as per LOI/contract.
 - The successful bidder/vendor refuses to honour the order after award of the same on him and/or withdraws his bid and/or unilaterally changes the offer and/or any of its items and conditions within the validity period.

EMD by the tenderer shall be withheld in case any action on the tenderer is envisaged under the provisions of extant "Guidelines on Suspension of business dealings with suppliers/contractors" and forfeited/released based on the action as determined under these guidelines".

Scan copy of documents in support of submission of EMD to be uploaded along with techno-commercial offer in e-procurement portal/platform. In case of EMD submission through banker's cheque/pay order/demand draft, same to be submitted in sealed envelope (superscribing tender reference) to Head-Purchase/ Manager-Purchase, BHEL Bhawan, DJ-9/1, Sector-2, Karunamoyee, Salt Lake City, Kolkata-700091, West Bengal prior to latest due date of submission of offer.

SPECIAL NOTE:

- A) **Your offer & documents submitted with the offer shall be signed and stamped in each page by your authorized representative. No overwriting/correction in tender documents by bidders shall be allowed. However, if correction is unavoidable, the same may be signed by authorized signatory.**
- B) **All documents/annexure submitted with the offer shall be properly annexed and placed in respective places of the offer as per enclosure list mentioned in the covering letter. BHEL shall not be responsible for any missing documents.**
5. No deviation with respect to tender clauses and no additional clauses/ suggestions/clarification in Techno-commercial bid/Price bid shall normally be considered by BHEL. Bidders are requested to positively comply with the same. Offers with deviation are liable for rejection.
6. BHEL reserves the right to accept or reject any or all offer without assigning any reasons thereof. BHEL also reserve the right to cancel the offer wholly or partly without assigning any reason thereof. BHEL also reserve the right to split/part award the job. Also BHEL shall not entertain any correspondence from bidders in this matter (except for the refund of EMD).
7. Bidders are free to visit the site and study the prevailing site condition including law & order etc. before quoting (if applicable). They may also consult this office before submitting their offers, for any clarifications regarding scope of work, facilities available at sites or on terms and conditions. No additional claim shall be entertained by BHEL in future, on account of non-acquaintance of site/machine conditions at the time of bidding.
8. For any clarification on the tender document, you may seek the same in writing or through e-procurement portal/platform as per specified format within the last date of seeking clarification as per tender. BHEL shall not be responsible for receipt of queries after due date of seeking clarification due to postal delay, and receipt of any query after due date shall not be entertained.
9. BHEL may decide holding Pre-bid Discussion [PBD] with all intending bidders. On such communication from BHEL, the bidder shall ensure participation for the same at the appointed time, date and place as may be decided by BHEL. Outcome of PBD (if any) shall also form part of tender.
10. In case of absence of any queries from bidder(s), their quoted price will be PRESUMED to be final and complete with reference to the tender documents (including Tender change notes (TCNs), clarifications, corrigendum issued by BHEL, if any). Bidders are requested to study the tender documents in detail and prepare their queries/clarifications accordingly. All such queries / clarifications shall be cleared/replied by BHEL. Such clarification letters, corrigendum and/or Tender change notes (TCNs), if issued by BHEL, shall form part of tender document.
11. In the event of any conflict between requirement of any clause of this specification/ documents /drawings /data sheets etc. or requirements of different codes/ standards specified/ contradictions between any two clauses of tender document, the same to be brought to the knowledge of BHEL by bidders in writing for clarification before due date of seeking clarification, otherwise, more stringent requirement as may be interpreted by BHEL shall prevail

- and shall be binding on you. Any typing error/missing pages/other clerical errors in the tender documents, noticed by you must be pointed out before submission of offer, or else, BHEL's interpretation shall prevail & binding on you.
12. Unless specifically mentioned otherwise, bidder's quoted price shall be deemed to be in compliance with tender including PBD.
 13. Tender document containing above mentioned volumes shall be signed & stamped in all pages including this covering letter. Price bid shall be furnished in the specified format enclosed with the tender. Any additional copy, if required, may be taken by photocopying from the tender document given in the web.
 14. **The Bidder has to satisfy the Pre-Qualifying Requirements stipulated for this Tender in order to be qualified. The Price Bids of only those bidders will be opened, who will qualify for the subject job on the basis of pre-qualification evaluation & Techno-Commercial bids etc. BHEL reserves the right to reject the bidders with unsatisfactory past performance in the execution of a contract. BHEL's decision in this regard shall be final & binding.**
 15. The bidder shall submit documents in support of possession of 'Pre-Qualifying Requirements' duly self-certified and stamped by the authorized signatory, indexed and properly linked in the format for PQR. In case BHEL requires any other documents/proofs, these shall be submitted immediately (if applicable).
 16. **The bidder may have to produce original document for verification if so decided by BHEL.**
 17. While BHEL reserves the right to open the price bid of the offers in camera, the date & time to open the tender opening shall be intimated to the bidders in case BHEL decides it to be 'Public opening' and in such a case, one authorized representative of the bidder shall be allowed to attend.
 18. Validity of the offer shall be as per PART-B, Cl - 17.
 19. Bidders are required to submit their BEST price as per tender Price Schedule format in e-procurement portal/platform in the form & manner as mentioned in tender.
 20. Price Bids shall be evaluated in the manner as prescribed in Price Schedule. However, Unit Rates shall also be furnished if applicable in the Price Schedule.
 21. **Bid should be free from correction, overwriting, using corrective fluid, etc. Any interlineation, cutting, erasure or overwriting shall be valid only if they are attested under full signature(s) of person(s) signing the bid else bid shall be liable for rejection.**
 22. Taxes and duties shall be as per PART- C of the tender. Statutory variation of taxes and duties (plus or minus) in accordance with Govt. Notifications to the account of BHEL. Any imposition of new / additional Duty / Tax at the time of supply shall be borne by BHEL.
 23. ***"BHEL shall be resorting to Reverse Auction (RA) (Guidelines as available on www.bhel.com) for this tender. RA shall be conducted among the techno-commercially qualified bidders. Price bids of all techno-commercially qualified bidders shall be opened and same shall be considered for RA. In case any bidder(s) do(es) not participate in online Reverse Auction, their sealed envelope price bid along with applicable loading, if any, shall be considered for ranking."***
 24. Bidders are requested to note that the accepted / agreed tender terms (technical, commercial or on Reverse Auction) in their original offer cannot be altered / withdrawn by their own during the processing of tender.
 25. Unsolicited discounts received after opening of techno commercial bid shall not be considered for evaluation. However, if the party who has submitted the unsolicited discount/rebate becomes the L-1 party, then the awarded price shall be after considering the discount.
 26. "The offers of the bidders who are under suspension as also the offers of the bidders, who engage the services of the firms debarred across BHEL, shall be rejected. The list of firms debarred across BHEL is available on BHEL web site www.bhel.com.
- 1.0 Integrity commitment, performance of the contract and punitive action thereof:
- 1.1 Commitment by BHEL:

BHEL commits to take all measures necessary to prevent corruption in connection with the tender process and execution of the contract. BHEL will during the tender process treat all Bidder(s) in a transparent and fair manner, and with equity.
 - 1.2 Commitment by Bidder/ Supplier/ Contractor:
 - 1.2.1 The bidder/ supplier/ contractor commit to take all measures to prevent corruption and will not directly or indirectly influence any decision or benefit which he is not legally entitled to nor will act or omit in any manner which tantamount to an offence punishable under any provision of the Indian Penal Code, 1860 or any other law in force in India.
 - 1.2.2 The bidder/ supplier/ contractor will, when presenting his bid, disclose any and all payments he has made, and is committed to or intends to make to agents, brokers or any other intermediaries in connection with the award of the contract and shall adhere to relevant guidelines issued from time to time by Govt. of India/ BHEL.

1.2.3 The bidder/ supplier/ contractor will perform/ execute the contract as per the contract terms & conditions and will not default without any reasonable cause, which causes loss of business/ money/ reputation, to BHEL.

If any bidder/ supplier/ contractor during pre-tendering/ tendering/ post tendering/ award/ execution/ post-execution stage includes in mal-practices, cheating, bribery, fraud or and other misconduct or formation of cartel so as to influence the bidding process or influence the price or acts or omits in any manner which tantamount to an offence punishable under any provision of the Indian Penal Code, 1860 or any other law in force in India, then, action may be taken against such bidder/ supplier/ contractor as per extant guidelines of the company available on www.bhel.com and/ or under applicable legal provisions”.

27. **The Bidder along with its associate/collaborators/sub-contractors/sub-vendors/consultants/service providers shall strictly adhere to BHEL Fraud Prevention Policy displayed on BHEL website <http://www.bhel.com> and shall immediately bring to the notice of BHEL management about any fraud or suspected fraud as soon as it comes to their notice.**

28. Suspension of Business dealings: BHEL reserves the right to take action against contractors who fail to perform or indulge in malpractices, by suspending business dealings with them as detailed in **Annexure-IV**.

29. "MSE suppliers can avail the intended benefits in respect of the procurements related to the Goods and Services only (Definition of Goods and Services as enumerated by Govt. of India vide Office Memorandum F. No. 21(8)/2011-MA dtd. 09/11/2016 office of AS & DC, MSME) if they submit along with the offer, attested copies of either Udyam Registration Certificate or EM II certificate having deemed validity (five years from the date of issue of acknowledgement in EM II) or valid NSIC certificate or Udyog Aadhar Memorandum (UAM) & Acknowledgement or EM II certificate along with attested copy of a CA certificate (Format enclosed at Annexure – V where deemed validity of EM II certificate of five years has expired) applicable for the relevant financial year (latest audited). Date to be reckoned for determining the deemed validity will be the date of bid opening (Part 1 in case of two part bid). Non submission of such documents will lead to consideration of their bid at par with other bidders. No benefit shall be applicable for this enquiry if any deficiency in the above required documents are not submitted before price bid opening. If the tender is to be submitted through e-procurement portal, then the above required documents are to be uploaded on the portal. Documents should be notarized or attested by a Gazetted officer."

Any Bidder falling under MSME category, shall furnish the following details & submit documentary evidence/Govt. Certificate etc. in support of the same along with their techno-commercial offer: -

Type under MSME	SC/ST owned	Others
Micro		
Small		
Medium		

Note: - If the bidder does not furnish the above, offer shall be processed construing that the bidder is not falling under MSME category.

30. PREFERENCE TO MAKE IN INDIA:

For this procurement, the local content to categorize a supplier as a Class-I local supplier/ Class-II local supplier/ Non-Local supplier and purchase preference to Class-I local supplier, is as defined in Public Procurement (Preference to Make in India), Order 2017 dated 04-06-2020 issued by DPIIT. In case of subsequent orders issued by the Nodal Ministry, changing the definition of local content for the items of the NIT, the same shall be applicable even if issued after issue of this NIT, but before opening of Part-II bids against this NIT.

Duly filled & signed Form-1 (Format for local content), as applicable, to be submitted by bidders along with their techno-commercial offer.

31. Compliance to Restrictions under Rule 144 (xi) of GFR 2017

- I. Any bidder from a country which shares a land border with India will be eligible to bid in this tender only if the bidder is registered with the Competent Authority. The Competent Authority for the purpose of this Clause shall be the Registration Committee constituted by the Department for Promotion of Industry and Internal Trade (DPIIT).
- II. "Bidder" (including the term 'tenderer', 'consultant' or 'service provider' in certain contexts) means any person or firm or company, including any member of a consortium or joint venture (that is an association of several persons, or firms or companies), every artificial juridical person not falling in any of the descriptions of bidders stated hereinbefore, including any agency branch or office controlled by such person, participating in a procurement process.
- III. "Bidder from a country which shares a land border with India" for the purpose of this Clause means: -
 - a. An entity incorporated established or registered in such a country; or
 - b. A subsidiary of an entity incorporated established or registered in such a country; or

- c. An entity substantially controlled through entities incorporated, established or registered in such a country; or
 - d. An entity whose beneficial owner is situated in such a country; or
 - e. An Indian (or other) agent of such an entity; or
 - f. A natural person who is a citizen of such a country; or
 - g. A consortium or joint venture where any member of the consortium or joint venture falls under any of the above
- IV. The beneficial owner for the purpose of (III) above will be as under:
- 1. In case of a company or Limited Liability Partnership, the beneficial owner is the natural person(s), who, whether acting alone or together or through one or more juridical person, has a controlling ownership interest or who exercises control through other means.
- Explanation
- a. "Controlling ownership interest" means ownership of or entitlement to more than twenty-five per cent of shares or capital or profits of the company.
 - b. "Control" shall include the right to appoint majority of the directors or to control the management or policy decisions including by virtue of their shareholding or management rights or shareholders agreements or voting agreements.
- 2. In case of a partnership firm, the beneficial owner is the natural person(s) who, whether acting alone or together, or through one or more juridical person, has ownership of entitlement to more than fifteen percent of capital or profits of the partnership.
 - 3. In case of an unincorporated association or body of individuals, the beneficial owner is the natural person(s), who, whether acting alone or together, or through one or more juridical person has ownership of or entitlement to more than fifteen percent of the property or capital or profits of the such association or body of individuals.
 - 4. Where no natural person is identified under (1) or (2) or (3) above, the beneficial owner is the relevant natural person who holds the position of senior managing official;
 - 5. In case of a trust, the identification of beneficial owner(s) shall include identification of the author of the trust, the trustee, the beneficiaries with fifteen percent or more interest in the trust and any other natural person exercising ultimate effective control over the trust through a chain of control or ownership.
- V. An Agent is a person employed to do any act for another, or to represent another in dealings with third person.
- VI. The successful bidder shall not be allowed to sub-contract works to any contractor from a country which shares a land border with India unless such contractor is registered with the Competent Authority.

Note:

- (i) The bidder shall provide undertaking for their compliance to this Clause, in the Format provided in Form-2.
 - (ii) Registration of the bidder with Competent Authority should be valid at the time of submission as well as acceptance of the bids.
32. "A bidder shall not have conflict of interest with other bidders. Such conflict of interest can lead to anti-competitive practices to the detriment of Procuring Entity's interests. **The bidder found to have a conflict of interest shall be disqualified.** A bidder may be considered to have a conflict of interest with one or more parties in this bidding process, if:
- a) they have controlling partner (s) in common; **or**
 - b) they receive or have received any direct or indirect subsidy/ financial stake from any of them; **or**
 - c) they have the same legal representative/agent for purposes of this bid; **or**
 - d) they have relationship with each other, directly or through common third parties, that puts them in a position to have access to information about or influence on the bid of another Bidder; **or**
 - e) Bidder participates in more than one bid in this bidding process. Participation by a Bidder in more than one Bid will result in the disqualification of all bids in which the parties are involved. However, this does not limit the inclusion of the components/ sub-assembly/ Assemblies from one bidding manufacturer in more than one bid, **or**
 - f) In cases of agents quoting in offshore procurements, on behalf of their principal manufacturers, one agent cannot represent two manufacturers or quote on their behalf in a particular tender enquiry. One manufacturer can also authorize only one agent/dealer. There can be only one bid from the following:
 - 1. The principal manufacturer directly or through one Indian agent on his behalf; and
 - 2. Indian/foreign agent on behalf of only one principal,**or**
 - g) A Bidder or any of its affiliates participated as a consultant in the preparation of the design or technical specifications of the contract that is the subject of the Bid; **or**
In case of a holding company having more than one independently manufacturing units, or more than one unit

having common business ownership/management, only one unit should quote. Similar restrictions would apply to closely related sister companies. Bidders must proactively declare such sister/ common business/ management units in same/ similar line of business."

33. BREACH OF CONTRACT, REMEDIES AND TERMINATION:

In case of breach of contract, wherever the value of security instruments like performance bank guarantee available with BHEL against the said contract is at least 10% of the contract value, the same be encashed. In case the value of security instruments available is less than 10% of the contract value, the balance amount be recovered from other financial remedies (i.e. available bills of the contractor, retention amount, etc. with BHEL) or legal remedies be pursued. The balance scope shall be got done independently without

Risk & Cost of the failed supplier/ contractor.

Further levy of Liquidated damages, debarment, termination, de-scoping, short-closure, etc. shall be applied as per provisions of the contract.

34. GeMAR and PTS Report ID: GEM/GARPTS/08122023/J0SOXKVRL8GM dtd. 08/12/23, GEM/GARPTS/08122023/CCNY1OL2CQ7 dtd. 08/12/23, GEM/GARPTS/12122023/Y69WAARVWO2L dtd. 12/12/23.

35. The GeM Seller ID shall be mandatorily submitted before placement of order / award of contract for goods and services by the successful bidder(s).

36. ORDER OF PRECEDENCE:

In the event of any ambiguity or conflict between the Tender Documents, the order of precedence shall be in the order below:

- AMENDMENTS/CLARIFICATIONS/CORRIGENDA/ERRATA etc issued in respect of the tender documents by BHEL.
- NOTICE INVITING TENDER (NIT)
- PRICE SCHEDULE: PART- E
- TECHNICAL SPECIFICATION/SCOPE AND SPECIAL CONDITIONS OF CONTRACT (SCC)-PART-C
- GENERAL CONDITIONS OF CONTRACT (GCC)-PART-B
- FORMS AND PROCEDURES

for BHARAT HEAVY ELECTRICALS LTD

Dy.Manager/ (PUR)

All the bidders are requested to note that all the errata / technical clarifications / corrigendum / extension etc. shall be published THROUGH E-PROCUREMENT PORTAL (<https://eprocurebhel.co.in>) and in website www.bhel.com & <http://eprocure.gov.in>. As such, all the bidders are requested to be in continuous touch with these websites.

Agency	Contact details	
BHEL, PSER, Kolkata	Address	BHARAT HEAVY ELECTRICALS LIMITED, POWER SECTOR – EASTERN REGION 2ND FLOOR, BLOCK-DJ, PLOT- 9/1, SECTOR, SALT LAKE CITY, KOLKATA – 700 091
	Phone no.	033-23398222, 23398221, 23398220
	FAX no.	033-23211960
	E-mail ID	pritam@bhel.in , a_sarkar@bhel.in , smandol@bhel.in
NIC E-PROCUREMENT PORTAL	<p>For E-Procurement Assistance & Training, NIC PORTAL Helpdesk Contacts as per following: - For any technical related queries please call at 24 x 7 Help Desk Number 0120-4001 002, 0120-4200 462, 0120-4001 005, 0120-6277 787</p> <p>Email Support Address: A) For any Issues or Clarifications relating to the published tenders, bidders are requested to contact the respective Tender Inviting Authority Technical - support-eproc@nic.in</p>	

Enclosures:

- ANNEXURE-I: Pre qualifying Criteria.
- ANNEXURE-II : No Deviation Certificate
- ANNEXURE-III: Format for Self Certification regarding Local content (LC) for Product/ Services/ Works
- ANNEXURE-IV: CERTIFICATE (regarding bidder from a country which shares a land border with India)
- ANNEXURE-V: Certificate by Chartered Accountant
- ANNEXURE-VI: Format for seeking clarification
- ANNEXURE-VII: Suspension of business dealing with Suppliers/Contractors
- ANNEXURE-VIII: Declaration for Relation in BHEL
- PART – F: General Terms & conditions for Reverse Auction.
- Tender documents as per this NIT.

PRE-QUALIFICATION CRITERIA

JOB	SUPPLY AND COMMISSIONING OF FLUE GAS ANALYZER, SPECTROPHOTOMETER AND PRESSURE TRANSMITTER AND DIFFERENTIAL PRESSURE TRANSMITTER FOR BHEL PSER - HQ KOLKATA.
TENDER NO	PSER:PUR:TSX:180(I):083 (ENQ:23:PP:0015:PUR:80) DATE: 04/01/2024

Sr. No.	CRITERIA
1.0	FINANCIAL CRITERIA
	<p>A. BIDDER SHOULD HAVE AN AVERAGE ANNUAL TURNOVER OF RUPEES 11.97 LAKHS DURING THREE CONSECUTIVE FINANCIAL YEARS 2020-21, 2021-22 AND 2022-23 AND SHOULD SUBMIT THEIR AUDITED BALANCE SHEET AND PROFIT&LOSS ACCOUNT IN SUPPORT OF THE SAME.</p> <p>B. INCASE AUDITED BALANCE SHEET AND PROFIT&LOSS ACCOUNT HAVE NOT BEEN SUBMITTED FOR THAT THREE CONSECUTIVE YEARS AS INDICATED ABOVE, THEN THE APPLICABLE FINANCIAL AUDITED SATEMENTS SUBMITTED BY THE BIDDERS AGAINST THE REQUISITE YEARS WILL BE AVERAGED FOR THREE YEARS.</p> <p>C. IF FINANCIAL STATEMENTS ARE NOT REQUIRED TO BE AUDITED STATUTORILY, THEN INSTEAD OF AUDITED FINANCIAL STATEMENTS, FINANCIAL STATEMENTS ARE REQUIRED TO BE CERTIFIED BY CHARTERED ACCOUNTANT.</p>
2.0	TECHNICAL CRITERIA
SPECTROPHO TOMETER	<p>1) BIDDER SHALL EITHER BE AN ORIGINAL EQUIPMENT MANUFACTURER (OEM) OR AUTHORIZED REPRESENTATIVE OF OEM. IN CASE OF AUTHORIESED REPRESENTATIVE OF OEM, THE VALID AUTHORISATION CERTIFICATE (FROM OEM IN THE NAME OF THE BIDDER) TO BE SUBMITTED ALONG WITH THE OFFER.</p> <p>2) THE BIDDER SHOULD HAVE SUPPLIED AT LEAST ONE SPECTROPHOTOMETER OF SAME OR BETTER RANGE (SILICA, IRON AND PHOSPHATE MEASUREMENT) ALONG WITH CALIBRATION CERTIFICATE AS PER TENDER REQUIREMENT TO REPUTED ORGANIZATIONS (USER) DURING LAST THREE YEARS ENDING LAST DATE OF BID SUBMISSION</p> <p>FOLLOWING DOCUMENTS ARE TO BE SUBMITTED BY THE BIDDER IN SUPPORT OF THE ABOVE: -</p> <p>a) PO COPY (IN THE NAME OF THE BIDDER ONLY) ALONG WITH PERFORMANCE CERTIFICATE OR COMMISSIONING REPORT OR PROOF OF INSTALLATION SHALL BE SUBMITTED BY THE BIDDER.</p> <p>b) COPY OF CALIBRATION CERTIFICATE OR UNDERTAKING OF SUPPLYING THE CALIBRATION CERTIFICATE AS PER TENDER REQUIREMENT DURING THE ACTUAL SUPPLY OF THE ITEM IN CASE OF PLACEMENT OF ORDER</p> <p>3) OEM OR BIDDER SHOULD HAVE AT LEAST ONE AUTHORISED SERVICE CENTRE IN INDIA FOR THE OFFERED PRODUCT. BIDDER MUST FURNISH THE DOCUMENTS IN SUPPORT OF THIS CREDENTIAL THROUGH ITS AUTHORISED LETTER/WEBSITE.</p>
FLUE GAS ANALYZER	<p>1) BIDDER SHALL EITHER BE AN ORIGINAL EQUIPMENT MANUFACTURER (OEM) OR AUTHORIZED REPRESENTATIVE OF OEM. IN CASE OF AUTHORIESED REPRESENTATIVE OF OEM, THE VALID AUTHORISATION CERTIFICATE (FROM OEM IN THE NAME OF THE BIDDER) TO BE SUBMITTED ALONG WITH THE OFFER.</p> <p>2) THE BIDDER SHOULD HAVE SUPPLIED AT LEAST ONE FLUE GAS ANALYZER OF SAME OR BETTER RANGE (OXYGEN %) ALONG WITH CALIBRATION CERTIFICATE AS PER TENDER REQUIREMENT TO REPUTED ORGANIZATIONS (USER) DURING LAST THREE YEARS ENDING LAST DATE OF BID SUBMISSION</p> <p>FOLLOWING DOCUMENTS ARE TO BE SUBMITTED BY THE BIDDER IN SUPPORT OF THE ABOVE: -</p>

	<p>a. PO COPY (IN THE NAME OF THE BIDDER ONLY) ALONG WITH PERFORMANCE CERTIFICATE OR COMMISSIONING REPORT OR PROOF OF INSTALLATION SHALL BE SUBMITTED BY THE BIDDER.</p> <p>b. COPY OF CALIBRATION CERTIFICATE OR UNDERTAKING OF SUPPLYING THE CALIBRATION CERTIFICATE AS PER TENDER REQUIREMENT DURING THE ACTUAL SUPPLY OF THE ITEM IN CASE OF PLACEMENT OF ORDER</p> <p>3) OEM OR BIDDER SHOULD HAVE AT LEAST ONE AUTHORISED SERVICE CENTRE IN INDIA FOR THE OFFERED PRODUCT. BIDDER MUST FURNISH THE DOCUMENTS IN SUPPORT OF THIS CREDENTIAL THROUGH ITS AUTHORISED LETTER/WEBSITE.</p>
PRESSURE-TRANSMITTERS (PTS) & DIFFERENTIAL PRESSURE-TRANSMITTERS (DPTS)	<p>1) THE BIDDER SHOULD BE AN ORIGINAL EQUIPMENT MANUFACTURER OF PRESSURE TRANSMITTERS, DIFFERENTIAL PRESSURE TRANSMITTERS AND HART COMMUNICATOR.</p> <p>2) THE BIDDER SHOULD HAVE SUPPLIED PRESSURE TRANSMITTERS/DIFFERENTIAL PRESSURE TRANSMITTERS OF INR 20 LAKHS (OR EQUIVALENT USD/EURO/JPY OR HOME CURRENCY FOR FOREIGN SUPPLIERS) OR MORE IN MAXIMUM OF TWO PURCHASE ORDERS TO ANY CUSTOMER IN LAST FIVE FINANCIAL YEARS 2018-2023. RELEVANT SUPPORTING DOCUMENTS ALONG WITH ORDER COPY WITH PERFORMANCE CERTIFICATE OR COMMISSIONING REPORT OR PROOF OF INSTALLATION SHALL BE SUBMITTED BY THE BIDDER.</p> <p>3) THE BIDDER SHOULD HAVE AT LEAST ONE AUTHORISED SERVICE CENTRE IN INDIA FOR THE OFFERED PRODUCT. BIDDER MUST FURNISH THE DOCUMENTS IN SUPPORT OF THIS CREDENTIAL THROUGH ITS AUTHORISED LETTER/WEBSITE.</p>

NOTES

1.	CONSORTIUM / JV BIDDING IS NOT ALLOWED.
2.	BIDDER SHOULD HAVE VALID PAN. RELEVANT SUPPORTING DOCUMENTS SHALL BE SUBMITTED.
3.	AFTER SATISFACTORY FULFILMENT OF ALL THE ABOVE CRITERIA, OFFER SHALL BE CONSIDERED FOR FURTHER EVALUATION AND PARTICIPATION AS PER NIT AND ALL OTHER TERMS OF THE TENDER.

NO DEVIATION CERTIFICATE**(TO BE SUBMITTED IN BIDDER'S LETTERHEAD)**

To
 BHARAT HEAVY ELECTRICALS LIMITED,
 Power Sector - Eastern Region,
 Plot no 9/1, DJ Block, Sector – II, Salt Lake City,
 Kolkata – 700 091

Sub	NO DEVIATION CERTIFICATE	
Job	SUPPLY AND COMMISSIONING OF FLUE GAS ANALYZER, SPECTROPHOTOMETER AND PRESSURE TRANSMITTERs & DIFFRENTIAL PRESSURE TRANSMITTERs FOR BHEL PSER - HQ KOLKATA.	
Ref	1.0	TENDER NO - PSER:PUR:TSX:180(I):083 (ENQ:23:PP:0015:PUR:80) DATE: 04/01/2024
	2.0	Other references (if any).

Dear Sir,

With reference to above tender, this is to confirm you that we have gone through each and every terms and conditions mentioned in the enquiry (Terms and Conditions) and we offer our unqualified acceptance of the same. This is also to confirm that as per tender conditions, we have visited site before submission of our offer and noted the job content & site conditions etc.

We also confirm that we have not changed/modified the tender documents as appeared in the website/newspapers and in case of observance at any stage, it shall be treated as null and void.

We hereby confirm that we have not taken any deviation from tender clauses together with other references as enumerated in the above referred NIT *and confirm our acceptance to **reverse auctioning process*** and we hereby convey our unqualified acceptance to all terms and conditions as stipulated in the tender and NIT.

It is also confirmed that the price has been quoted in the format received with the enquiry. We confirm that, we do not have any objections to splitting the quantity among the different bidders by BHEL and price shall remain firm till the completion supply of full ordered quantity.

Any deviation found subsequently at any time during execution of order shall be treated null and void.

Thanking you,

Yours faithfully,

(Signature, date & seal of authorised representative of the contractor)

पावर सेक्टर पूर्वी क्षेत्र (मुख्यालय) POWER SECTOR EASTERN REGION, DJ-9/1, SALT LAKE CITY, KOLKATA - 700 091 फैक्स/Fax: (033) 23211960 फोन/Phone: बोर्ड/EPABX: 23398220	Page - 10 of 37
---	-----------------

**DECLARATION REGARDING MINIMUM LOCAL CONTENT IN LINE WITH
REVISED PUBLIC PROCUREMENT (PREFERENCE TO MAKE IN INDIA), ORDER 2017 DATED 04TH JUNE, 2020
AND SUBSEQUENT ORDER(S)**

(To be typed and submitted in the Letter Head of the Entity/Firm providing certificate as applicable)

To,

(Write Name & Address of Officer of BHEL inviting the Tender)

Dear Sir,

Sub: Declaration reg. minimum local content in line with Public Procurement (Preference to Make in India), Order 2017-Revision, dated 04th June, 2020 and subsequent order(s).

Ref : 1) NIT/Tender Specification No: PSER:PUR:TSX:180(I):083 (ENQ:23:PP:0015:PUR:80) DATE: 04/01/2024,
2) All other pertinent issues till date

We hereby certify that the items/works/services offered by..... *(specify the name of the organization here)* has a local content of _____ % and this meets the local content requirement for '**Class-I local supplier**' / '**Class II local supplier**' ** as defined in Public Procurement (Preference to Make in India), Order 2017-Revision dated 04.06.2020 issued by DPIIT and subsequent order(s).

The details of the location(s) at which the local value addition is made are as follows:

- | | |
|----------|----------|
| 1. _____ | 2. _____ |
| 3. _____ | 4. _____ |
| ... | |
| ... | |
| ... | |

Thanking you,
Yours faithfully,

(Signature, Date & Seal of Authorized Signatory of the Bidder)

** - *Strike out whichever is not applicable.*

Note:

1. Bidders to note that above format Duly filled & signed by authorized signatory, shall be submitted along with the techno-commercial offer.
2. In case the bidder's quoted value is in excess of Rs.10 crores, the authorised signatory for this declaration shall necessarily be the statutory auditor or cost auditor of the company (in case of companies) or a practising cost accountant or practicing chartered accountant (in respect of suppliers other than companies)
3. In the event of false declaration, actions as per the above order and as per BHEL Guidelines shall be initiated against the bidder.

DECLARATION REGARDING COMPLIANCE TO RESTRICTIONS UNDER RULE 144 (xi) OF GFR 2017

(To be submitted in the bidder's letter head)

To,

(Write Name & Address of Officer of BHEL inviting the Tender)

Dear Sir,

Sub: Declaration regarding compliance to Restrictions under Rule 144 (xi) of GFR 2017

Ref: 1) NIT/Tender Specification No: PSER:PUR:TSX:180(I):083 (ENQ:23:PP:0015:PUR:80) DATE: 04/01/2024,
2) All other pertinent issues till date

I have read the clause regarding restrictions on procurement from a bidder of a country which shares a land border with India. I certify that _____ *(specify the name of the organization here)*, is not from such a country / has been registered with the Competent Authority *(attach valid registration by the Competent Authority, i.e., the Registration Committee constituted by the Dept. for Promotion of Industry and Internal Trade (DPIIT)); (attach relevant valid registration, if applicable)*

I hereby certify that we fulfil all requirements in this regard and is eligible to be considered.

Thanking you,
Yours faithfully,

(Signature, Date & Seal of Authorized Signatory of the Bidder)

Note: Bidders to note that in case above certification given by a bidder, whose bid is accepted, is found to be false, then this would be a ground for immediate termination and for taking further action in accordance with law and as per BHEL guidelines.

Certificate by Chartered Accountant on letter head

This is to Certify that M/s, (hereinafter referred to as 'company') having its registered office at is registered under MSMED Act 2006, (Entrepreneur Memorandum(Part-II) / UAM / Udyam Registration No..... dtd:....., Category: (Micro/Small). (Copy enclosed).

Further verified from the Books of Accounts that the investment of the company as per the latest audited financial year..... as per MSMED Act 2006 is as follows:

1. **For Manufacturing Enterprises:** Investment in plant and machinery (i.e. original cost excluding land and building and the items specified by the Ministry of Small Scale Industries vide its notification No.S.O.1722(E) dated October 5, 2006:
Rs Lacs
2. **For Service Enterprises:** Investment in equipment (original cost excluding land and building and furniture, fittings and other items not directly related to the service rendered or as may be notified under the MSMED Act, 2006:
Rs Lacs
3. **For Enterprises (having EM-Part-II / UAM):** Investment in plant and machinery or equipment is Rs..... Lacs and turnover is Rs.Lacs {as notified in MSME notification no. S.O. 2119 (E) dated 26-06-2020}.
4. **For Enterprises (Udyam, registered under Udyam Registration Portal):** Investment in plant and machinery or equipment is Rs.....Lacs and turnover is Rs.....Lacs {as notified in MSME notification no. S.O. 2119 (E) dated 26-06-2020}.

(Strike off whichever is not applicable)

The above investment of Rs.....Lacs is within permissible limit of Rs.....Lacs forMicro/Small (Strike off which is not applicable) Category under MSMED Act 2006.

Or

The company has been graduated from its original category {Micro/Small} (Strike off which is not applicable) and the date of graduation of such enterprise from its original category is (dd/mm/yyyy) which is within the period of 3 years from the date of graduation of such enterprise from its original category as notified vide S.O. No. 3322(E) dated 01.11.2013 published in the gazette notification dated 04.11.2013 by Ministry of MSME.

Date:

(Signature)

Name-

Membership number –

Seal of Chartered Accountant

पावर सेक्टर पूर्वी क्षेत्र (मुख्यालय) POWER SECTOR EASTERN REGION, DJ-9/1, SALT LAKE CITY, KOLKATA - 700 091 फैक्स/Fax: (033) 23211960 फोन/Phone: बोर्ड/EPABX: 23398220	Page - 13 of 37
--	-----------------

FORMAT FOR SEEKING CLARIFICATION

Job	SUPPLY AND COMMISSIONING OF FLUE GAS ANALYZER, SPECTROPHOTOMETER AND PRESSURE TRANSMITTERs & DIFFRENTIAL PRESSURE TRANSMITTERs FOR BHEL PSER - HQ KOLKATA.			
Tender No	PSER:PUR:TSX:180(I):083 (ENQ:23:PP:0015:PUR:80) DATE: 04/01/2024			
Sl. no	Reference clause of tender document	Existing provision	Bidder's query	BHEL's clarification

1.0	<u>Suspension of Business dealings with Suppliers/ Contractors</u>
1.1	BHEL reserves the right to take action against Suppliers/ Contractors who fail to perform or indulge in malpractices, by suspending business dealings with them.
1.2	<p>Suspension of business dealings with Suppliers/ Contractors could be in the form of following:</p> <p>a. Debarment within the unit for specific item(s)/ material category(ies)/ type of work(s) for six months.</p> <p>b. Debarment within the unit for all item(s)/ material category(ies)/ type of work(s) for one year.</p> <p>c. Debarment across BHEL for all items/ material category(ies)/ type of work(s) for two years.</p> <p>The Supplier may be debarred, as detailed hereinafter on the basis of one or more of the category wise reasons as enumerated hereunder:</p>
1.2.1	<p>Debarment within the unit for a specific item(s)/ material category(ies)/ type of work(s) shall be imposed for six months in the following cases, if</p> <p>i. In the last three consecutive supplies of a specific material category, average quality rating, as provided in the supplier performance rating (SPR) as per SEARP, falls below 80% of the quality weightage. This is irrespective of supplies against PO(s) having single/ multiple delivery schedules.</p> <p>Note: Not applicable in cases for erection works of Power Sector Regions, where separate guidelines for evaluation of capacity of bidders is being followed.</p> <p>ii. Two consecutive delays, for reasons of delay attributed to the Supplier, in execution of the contracts where delay occurred is such that</p> <p>a. prescribed maximum LD time limits of the contracts is exceeded or</p> <p>b. delay period has equaled/ exceeded half the original delivery period specified in the contracts</p> <p>whichever among the above is earlier.</p> <p>iii.</p> <p>a. Overall SPR (Supplier Performance Rating) in that particular Unit in line with SEARP falls below 60% of the specific material category.</p> <p>b. Bids of contractors (in PS-MSX portal) shall not be considered (if average score of last six months falls 60% or below as per guidelines for evaluation of capacity of bidders formula).</p> <p>Note: – for (b), No specific period of Debarment shall be applicable.</p> <p>iv.</p> <p>a. Supplier works are under strike/ lockout for a period of more than three months.</p> <p>b. Contractor has resorted to wanton stalling of work, strikes, picketing etc. during currency of</p>

1.2.2	<p>Debarment within the unit for all item(s)/ material category(ies)/ type of work(s) shall be imposed for One year in the following cases, if</p> <ul style="list-style-type: none"> i. Supplier tampers with tendering procedure affecting ordering process. ii. Supplier has misused BHEL documents/ drawings/ technical information or has breached the confidentiality agreement with BHEL. iii. after placement of order, Supplier fails to execute the contract. iv. within warranty period as per contract, Supplier continues to supply low/ less/ non-performing equipment/ services, repetitive failures, remains non-responsive. v. Wherever any part or full scope of supply/ work/ service has been awarded at the Risk and Cost of the defaulting vendor and the unexecuted value of scope for which the Risk and Cost action taken is more than 5% of the contract value. vi. After price bid opening but before placement of order, Supplier withdraws his offer or varies it in any manner within the validity period. vii. In spite of warnings, the Supplier persistently violates or circumvents the provisions of labour laws/ regulations/ rules or other statutory requirements.
1.2.3	<p>Debarment across BHEL shall be imposed for two years in following cases, if</p> <ul style="list-style-type: none"> i. Supplier has made false declaration and/ or provided false information and/ or forged documents or has forged BHEL documents, certificates etc. for securing business, meeting PQR or for enlistment in BHEL or with other customers. ii. Supplier is found to be involved in cartel formation or in any other act so as to influence the bidding process or influence the price of the tender. iii. The Supplier has indulged in malpractices or misconduct such as bribery, corruption and fraud, pilferage, coercion, etc. iv. The Supplier is found guilty by any court of law for criminal activity/ offences involving moral turpitude in relation to business dealings. v. Supplier is found to have obtained any internal information/ documentation of BHEL by unauthorized means. vi. The foreign Principals along with the representing Agent shall be debarred together if information submitted jointly by them about their precise relationship, commission/ remuneration etc. payable/ receivable and other particulars as asked by BHEL, as per the extant guidelines regarding dealing with Agents of Foreign Suppliers is found false/ incorrect, at any stage. vii. Supplier has, damaged, failed to return free issue materials/tools etc. of BHEL, for which recovery could not be affected against such materials, or substituted free issue materials/ tools etc. of BHEL. viii. Supplier has been declared insolvent or is under dissolution/ insolvency proceedings so as to affect the execution of work. ix. The Supplier has tarnished/ maligned the image of BHEL or unfairly acted in a manner prejudicial to the commercial interest of BHEL or breached the confidentiality of the vital information with an intent to prejudice the interest of BHEL.
1.2.4	<p>A Supplier can also be debarred with the approval of Director (E, R&D) provided a direction to this effect has been received from the administrative ministry of the Government.</p>

Note: Above shall be applicable along with [Guidelines for “Suspension of Business dealings with Suppliers/ Contractors”](http://www.bhel.com) available in BHEL website <http://www.bhel.com>. These shall form part of tender documents.

Note: Above shall be applicable along with [Guidelines for “Suspension of Business dealings with Suppliers/ Contractors”](http://www.bhel.com) available in BHEL website <http://www.bhel.com>. These shall form part of tender documents.

DECLARATION FOR RELATION IN BHEL

(To be typed and submitted in the Letter Head of the Company/Firm of Bidder failing which the offer of Bidder is liable to be summarily rejected)

To,

(Write Name & Address of Officer of BHEL inviting the Tender)

Dear Sir,

Sub: **Declaration for relation in BHEL**

Ref : 1) NIT/Tender Specification No: **PSER:PUR:TSX:180(I):083 (ENQ:23:PP:0015:PUR:80)** DATE: **04/01/2024**,

I/We hereby submit the following information pertaining to relation/relatives of Proprietor/Partner(s)/Director(s) employed in BHEL.

Tick (√) any one as applicable:

1. The Proprietor, Partner(s), Director(s) of our Company/Firm DO NOT have any relation or relatives employed in BHEL

OR

2. The Proprietor, Partner(s), or Director(s) of our Company/Firm HAVE relation/relatives employed in BHEL and their particulars are as below:

(i)

(ii)

Signature of the Authorized Signatory

Note:

1. Attach separate sheet, if necessary.
2. If BHEL Management comes to know at a later date that the information furnished by the Bidder is false, BHEL reserves the right to take suitable against the Bidder/Contractor.

=====

DECLARATION

Date: -----

Job: "SUPPLY AND COMMISSIONING OF FLUE GAS ANALYZER, SPECTROPHOTOMETER AND PRESSURE TRANSMITTERs & DIFFERENTIAL PRESSURE TRANSMITTERs FOR BHEL PSER - HQ KOLKATA".

E-Tender No.: PSER:PUR:TSX:180(I):083 (ENQ:23:PP:0015:PUR:80) DATE: 04/01/2024

To: -----
Address: BHEL, -----

Email: -----

Sub: **Details of related firms and their area of activities**

Dear Sir/Madam,

Please find below details of firms owned by our family members that are doing business/registered for same item with BHEL, ----- (NA, if not applicable)

1	Material Category/ Work Description	
	Name of Firm	
	Address of Firm	
	Nature of Business	
	Name of Family Member	
	Relationship	
2	Material Category/ Work Description	
	Name of Firm	
	Address of Firm	
	Nature of Business	
	Name of Family Member	
	Relationship	
...		

Note: I certify that the above information is true and I agree for penal action from BHEL in case any of the above information furnished is found to be false.

Regards,

(-----)

From: M/s -----

Supplier Code: -----

Address: -----

PART - F

GENERAL TERMS & CONDITIONS OF REVERSE AUCTION

Against this enquiry for the subject item/ system with detailed scope of supply/service as per tender specifications, BHEL shall be resorting to "REVERSE AUCTION PROCEDURE" i.e. ON LINE BIDDING (THROUGH A SERVICE PROVIDER). The philosophy followed for reverse auction shall be English Reverse (No ties).

1. For the proposed reverse auction, technically and commercially acceptable bidders only shall be eligible to participate.
2. *Price bids of all techno-commercially qualified bidders shall be opened and same shall be considered for RA.*
3. BHEL will engage the services of a service provider who will provide all necessary training and assistance before commencement of on line bidding on internet.
4. In case of reverse auction, BHEL will inform the bidders the details of Service Provider to enable them to contact & get trained for participation in the reverse auction.
5. Business rules like event date, time, bid decrement, extension etc. also will be communicated through service provider for compliance.
6. Bidders have to fax /e-mail the Compliance form (annexure III) before start of Reverse auction. Without this, the bidder will not be eligible to participate in the event.
7. In line with the NIT terms, BHEL will provide the calculation sheet (e.g., EXCEL sheet) which will help to arrive at "Total Cost to BHEL" which is inclusive of all cost elements in line with terms & conditions of the tender for each of the bidder to enable them to fill-in the price and keep it ready for keying in during the Auction.
8. Reverse auction will be conducted on scheduled date & time.
9. At the end of Reverse Auction event, the lowest bidder value will be known on auction portal.
10. The lowest bidder has to fax/e-mail the duly signed and filled-in prescribed format for price breakup including that of line items, if required, (Annexure VI) as provided on case-to-case basis to Service provider within two working days of Auction without fail.
11. *Bidders shall be required to read the "Terms and Conditions" section of the auctions site of Service provider, using the Login IDs and passwords given to them by the service provider before reverse auction event. Bidders should acquaint themselves of the "Business Rules of Reverse Auction", which will be communicated before the Reverse Auction.*
12. The Bidder shall not divulge either his Bids or any other exclusive details of BHEL to any other party. If the Bidder or any of his representatives are found to be involved in Price manipulation/ cartel formation of any kind, directly or indirectly by communicating with other bidders, action as per extant BHEL guidelines for suspension of business dealings (as available on www.bhel.com), shall be initiated by BHEL and the results of the RA scrapped/ aborted.
13. *Reverse Auction will be conducted if two or more bidders are techno-commercially qualified. In case of two or three qualified bidders, there shall be no elimination of H1 bidder (whose quote is highest in sealed envelope price bid). In case of four qualified bidders, the H1 bidder shall be eliminated whereas in case of five qualified bidders, H1 & H2 bidders shall be eliminated. However, in case of six or more qualified bidders are available, RA would be conducted amongst first 50% of the bidders arranged in the order of prices from lowest to highest. Number of bidders eligible for participating in RA would be rounded off to next higher integer value if number of qualified bidders is odd (e.g. if 7 bids are qualified, then RA will be conducted amongst lowest four bidders). However, there will be no elimination of qualified bidders who are MSE or qualifying under PPP-MII, Order 2017, provided their bids are within their respective margin of purchase preference {presently 15% for MSEs and 20% for PPP-MII, or as amended from time to time}.*

In case of multiple H1 bidders, all H1 bidders (except MSEs and bidders qualifying under PPP-MII, Order 2017, who are within the margin of purchase preference) shall be removed provided minimum two bidders remain in fray, else no H1 removal.

PART – B: GENERAL CONDITIONS OF CONTRACT (GCC)

SL. NO.	BHEL STANDARD TERMS	Bidder's confirmation	Deviation
1.	<p>Our requirement is for CAPITAL use and will be used at BHEL PSER-HQ KOLKATA. Techno-commercial & Pre-Q bids shall be opened first & afterwards price bid shall be opened for qualified bidder(s), who have qualified in Techno-commercial & Pre-Q bids. Tenders will be received up to 14.00 Hours on the said due date. <u>If the vendor submits offer i.e. Technical & Price bid together in single attachment, the offer shall be liable for rejection.</u> <u>Price should be submitted as per tender format only & uploaded in the price section.</u> Note: In order to maintain sanctity of the tender system, it is advised that one Agent cannot represent two suppliers or quote on their behalf in a particular tender. In the tender, either one agent on behalf of the principal/OEM or Principal/OEM itself can bid but both cannot bid simultaneously for same item/product.</p>		
2.	If any vendor sought to quote through their agents "They have to inform to BHEL in advance, before opening date. Otherwise the offer will be treated as Unsolicited Offer and same will not be opened".		
3.	BHEL keeps its right to reject / load any offer which is having deviations to BHEL Specifications, Standard Terms & Conditions. All the bidders shall submit their offers only by filling the original BHEL tender documents. No other offer will be entertained. In case of Technical-Cum-Commercial bid, copy of the price bid has to be used to indicate commercial terms without price.		
4.	The equipment offered shall be strictly conforming to the specification and for complete unit.		
5.	No offer for individual accessories or part machinery will be accepted.		
6.	PAYMENT TERMS: AS PER PART-C of tender. No advance shall be paid. Payment shall be paid in INR only. Payment shall be through RTGS. Successful bidder shall have to submit the requisite details in RTGS format.		
7.	WARRANTY/GUARANTEE: AS PER PART-C of tender.		
8.	DELIVERY TERMS: AS PER PART-C of tender. <u>Offer with delivery period beyond tendered delivery schedule shall be liable for rejection.</u> However, in case due to any reasons if the same is accepted by BHEL, the same shall be loaded for the delayed delivery period (in this case after tendered delivery period) & percentage of loading shall be as per clause no 22 of GCC (LD clause).		
9.	DISCOUNTS: Discounts offered by the vendor in price shall not be entertained by BHEL. The vendor should factor in his discount in the price offer only. In-spite of the same, if a discount is offered by the bidder, the same shall not be considered for evaluation of the offer, but purchase order shall be issued on bidder's final discounted price.		
10.	LIQUIDATED DAMAGE/PENALTY CLAUSE: AS PER PART-C of tender.		
11.	Contract Execution Bank Guarantee/ Security Deposit (SD) & Performance Bank Guarantee (PBG) a. CEBG/SD: 10% of the total order value to be submitted within 30 days of placement of LOI and valid until 30 days after the date of commissioning certificate which will be issued on completion of successful commissioning of the equipment as per order. However, CEBG/SD may be converted to PBG in full after the date of issuance of commissioning certificate.		

	<p>b. PERFORMANCE BANK GUARANTEE (PBG): 10% of the total order value valid for 30 days beyond the warranty period. However, this PBG clause shall be applicable in case bidder opines to obtain last 20% of Supply value plus 100% of the Installation & Commissioning charges as per Payment terms.</p> <p>SDBG may be converted into PBG. However, PBG will be released only after completion of all contractual obligations or guarantee/warranty period plus 30 days, whichever is later.</p>		
12.	<p>The sealed tenders super scribing tender number and due date should be addressed to: Dy Manager/Purchase, Bharat Heavy Electricals Limited, PSER, BHEL BHAWAN, DJ-9/1, SALT LAKE, SECTOR-II, KOLKATA - 700 091, India.</p>	Not Applicable	
13.	<p>INSPECTION: Details shall be as per PART-C of tender.</p>		
14.	<p>CONSIGNEE DETAILS OF THE EQUIPMENT: - AS PER PART-C of tender. All documents / correspondences must bear the Tender no. / Purchase Order No. & Date.</p>		
15.	<p>The manufacturing progress will have to be furnished to us periodically in the form and manner required by us.</p>		
16.	<p>Supplier must submit with their offer list of customers (with their full address and their purchase reference number) to whom they have supplied similar machine in the past five years. The year of supply should also be indicated.</p>		
17.	<p>The quotation should be valid at least for a period of <u>NINETY (90) DAYS</u> from the tender due date of submission (extended, if any). Price Variation Clause will not be entertained.</p>		
18.	<p><u>FORCE MAJEURE:</u> The vendor shall be subject to force majeure clause defined as under : This force majeure is herein defined as any cause which is beyond the control of the tenderer which they would not have foreseen or with a reasonable amount of diligence could not have foreseen and which subsequently affect the performance of the contract such as SRCC (strike riot and civil commotion), earthquake, flood, acts of god, acts of any government, domestic or foreign including but not limited to war. The tenderer shall not be liable for delay in performing his obligation resulting from any force majeure clause as referred to and/or defined above. The date of completion will be subject to hereinafter provided be extended by a reasonable time even though such cause may occur after tenderer's performance of his obligation has been delayed for other causes.</p>		
19.	<p><u>ARBITRATION & CONCILIATION</u></p>		
19.1	<p><u>ARBITRATION :</u></p>		
19.1.1	<p>Except as provided elsewhere in this Contract, in case Parties are unable to reach amicable settlement (whether by Conciliation to be conducted as provided in Clause 19.2 herein below or otherwise) in respect of any dispute or difference; arising out of the formation, breach, termination, validity or execution of the Contract; or, the respective rights and liabilities of the Parties; or, in relation to interpretation of any provision of the Contract; or, in any manner touching upon the Contract (hereinafter referred to as the 'Dispute'), then, either Party may, commence arbitration in respect of such Dispute by issuance of a notice in terms of section 21 of the Arbitration & Conciliation Act, 1996 (hereinafter referred to as the 'Notice'). The Notice shall contain the particulars of all claims to be referred to arbitration in sufficient detail and shall also indicate the monetary amount of such claim. The arbitration shall be conducted by a sole arbitrator to be appointed by the Head of the BHEL Power Sector Region issuing the Contract within 60 days of receipt of the complete Notice. The language of arbitration shall be English.</p> <p>The Arbitrator shall pass a reasoned award.</p> <p>Subject as aforesaid, the provisions of Arbitration and Conciliation Act 1996 (India) or statutory modifications or re-enactments thereof and the rules</p>		
<p>पावर सेक्टर पूर्वी क्षेत्र (मुख्यालय) POWER SECTOR EASTERN REGION, DJ-9/1, SALT LAKE CITY, KOLKATA - 700 091 फैक्स/Fax: (033) 23211960 फोन/Phone: बोर्ड/EPABX: 23398220</p>			Page - 21 of 37

	made thereunder as in force from time to time shall apply to the arbitration proceedings under this clause. The seat of arbitration shall be Kolkata (the place from where the contract is Issued). The Contract shall be governed by and be construed as per provisions of the laws of India. Subject to this provision 19.1.1 regarding ARBITRATION, the principal civil court exercising ordinary civil jurisdiction over the area where the seat of arbitration is located shall have exclusive jurisdiction over any DISPUTE to the exclusion of any other court.		
19.1.2	In case of Contract with Public Sector Enterprise (PSE) or a Government Department, the following shall be applicable: In the event of any dispute or difference relating to the interpretation and application of the provisions of commercial contract(s) between Central Public Sector Enterprises (CPSEs)/ Port Trusts inter se and also between CPSEs and Government Departments/Organizations (excluding disputes concerning Railways, Income Tax, Customs & Excise Departments), such dispute or difference shall be taken up by either party for resolution through AMRCD (Administrative Mechanism for Resolution of CPSEs Disputes) as mentioned in DPE OM No. 4(1)/2013-DPE(GM)/FTS-1835 dated 22-05-2018 as amended from time to time.		
19.1.3	The cost of arbitration shall initially be borne equally by the Parties subject to the final allocation thereof as per the award/order passed by the Arbitrator.		
19.1.4	Notwithstanding the existence of any dispute or differences and/or reference for the arbitration, the Contractor shall proceed with and continue without hindrance the performance of its obligations under this Contract with due diligence and expedition in a professional manner unless the dispute inter-alia relates to cancellation, termination or short-closure of the Contract by BHEL.		
19.2	CONCILIATION: If at any time (whether before, during or after the arbitral or judicial proceedings), any Disputes (which term shall mean and include any dispute, difference, question or disagreement arising in connection with construction, meaning, operation effect, interpretation or breach of the agreement, contract), which the Parties are unable to settle mutually, arise inter-se the Parties, the same may, be referred by either party to Conciliation to be conducted through Independent Experts Committee (IEC) to be appointed by competent authority of BHEL from the BHEL Panel of Conciliators. Notes: 1. No serving or a retired employee of BHEL/Administrative Ministry of BHEL shall be included in the BHEL Panel of Conciliators. 2. Any other person(s) can be appointed as Conciliator(s) who is/are mutually agreeable to both the parties from outside the BHEL Panel of Conciliators. The proceedings of Conciliation shall broadly be governed by Part-III of the Arbitration and Conciliation Act 1996 or any statutory modification thereof and as provided in Procedure 2.3 to this GCC (as available in www.bhel.com). The Procedure 2.3 together with its Formats (as available in www.bhel.com) will be treated as if the same is part and parcel hereof and shall be as effectual as if set out herein in this GCC. The Contractor hereby agrees that BHEL may make any amendments or modifications to the provisions stipulated in the Procedure 2.3 (as available in www.bhel.com) to this GCC from time to time and confirms that it shall be bound by such amended or modified provisions of the Procedure 2.3 (as available in www.bhel.com) with effect from the date as intimated by BHEL to it.		
19.3	No Interest payable to Contractor Notwithstanding anything to the contrary contained in any other document comprising in the Contract, no interest shall be payable by BHEL to Contractor on any moneys or balances including but not limited to the Security Deposit, EMD, Retention Money, RA Bills or the Final Bill, or any amount withheld and/or appropriated by BHEL etc., which becomes or as the case may be, is adjudged to be due from BHEL to Contractor whether under the Contract or otherwise.		

20.	JURISDICTION: All disputes or differences arising out of or in connection with the Purchase Order shall be subject to the exclusive jurisdiction of Courts (pecuniary or territorial) viz Commercial Court Rajarhat/ District Court Barasat (24 PGN North) as the case may be and Calcutta High Court at Kolkata.		
21.	LOADING FACTORS FOR DEVIATION TO BHEL STANDARD TERMS & CONDITIONS		
i)	Bank Guarantee: Non submission of 10% BG (if applicable) will attract 10% loading on the offers.		
ii)	Penalty Clause: Non acceptance of penalty clause will attract maximum 10% loading on the offer and accordingly proportionate percentage will be loaded for accepting less percentage of penalty clause. Ex: If the supplier has accepted for maximum 5% penalty clause, then balance 5% will be loaded.		
iii)	For all other Terms & Conditions, if the offer is not confirming to the same, BHEL at its discretion shall load the same and the loading pattern shall be intimated to the bidders before price bid opening. However BHEL reserves the right to cancel a bid in case of non-acceptance of any terms and conditions finally arrived before price bid opening.		
23	Note: The offers not complying the above Terms & Conditions will not be accepted.		

Note:

01. In case of any conflict / inconsistency in any clause of the tender or between various sections of the tender, bidder should bring the same in writing to BHEL for clarification before submission of the bid, failing which the most stringent interpretation of the clause in favour of BHEL shall be adopted and the same shall be binding to the bidder.
02. Any deviation sought by the bidder should be indicated in the techno-commercial offer.
03. **Bidder should write “accepted” in the column “Bidder’s confirmation” for each clause, if the conditions are agreeable or else should write the deviations sought in “Bidder’s Deviation(if any)” column. Offers with deviation are liable for rejection.**
04. If any clause left blank, shall be presumed that the clause is accepted by the bidder.

SIGNATURE OF THE BIDDER WITH SEAL AND DATE

PART-C: TECHNICAL SCOPE AND SPECIAL TERMS AND CONDITIONS**1. Technical Specifications for 'FLUE GAS ANALYZER'**

SI No	Description	BHEL Requirement	Bidders Comment
1	Type	Portable & Handy Flue Gas Analyzer	
2	Measurement Function	Oxygen % in flue gas	
3	Measurement range	0-20 % Vol or better	
4	Measurement Accuracy	+/-1% or better	
5	Resolution	+/-0.1% vol or better	
6	Flue gas Draught	+/-0.03 bar or better	
7	Flue gas Pressure	0.3 bar or more	
8	Flue gas Temperature	450 deg C or more	
9	Probe Length	300 mm or more	
10	Display	VGA/TFT screen or better	
11	<u>General Specifications</u>		
	a) Operating environment	0 to 45°C or better, 35 to 80% RH (non-condensing)	
	b) Power supply	Rechargeable Battery operated with AC charging adaptor.	
	c) Weight of the Instrument	Less than 1 Kg	
12	<u>Standard Accessories</u>		
	a) Probe for O2 measurement - 01 no.		
	b) Instruction Manual - 1 No		
	c) Rechargeable Battery: 1 set		
	d) AC adapter 1no.		
	e) Suitable Compact Hard Carrying Case for the complete set- 1 No.		
	f) Test/Calibration Certificate : Valid certificate From OEM/ NABL accredited Lab (Validity for at least 1 Year).		
	g) Two sets of Consumables like line filters, o ring (if required) etc. to be supplied		
	g) Certificate of Newness		
h) Any other accessories required for full functioning of the Instrument must be supplied.			

NB:- Offered Model must have technical Comparison with BHEL Specification in tabular form, This is Must.

2. Technical Specification of 'SPECTROPHOTOMETER'

SI No	Description	BHEL' Requirement	Bidder's Comment
1	Operating mode	Minimum of Transmittance (%), Absorbance and Concentration	
2	Light source	Tungsten lamp	
3	Optical system	Reference beam technology	
4	Wavelength range	400 nm to 1100 nm or better	
5	Wavelength accuracy	+/-1.5 nm or better	
6	Wavelength reproducibility	0.2 nm or better	
7	Wavelength resolution	1 nm for part of the wavelength range or better	
8	Spectral bandwidth	5 nm or better	

9	Photometric measuring range	+/- 3.0 Abs for part or full range of wavelength	
10	Stray light	< 0.1 % T at 340 nm with NaNO ₂ or better	
11	Display	LCD/TFT Touchscreen	
12	Interface	Some kind of external connections USB storage or computer should be provided	
13	Data logger	Min 1000 data's	
14	Pre-programmed methods	> 200	
15	User programs	100 or more	
16	Operating condition	10 to 35 Deg C or better	
17	Storage condition	-10 to 60 °C or better	
18	Enclosure rating	IP 30 or better	
19	Weight	Not More than 8 KG	
20	Power Requirement	Suitable for Indian power supply	
21	Language	English	
22	Carrying Case	Suitable Compact Hard carrying Case	
23	Pre-programmed required for following parameters:	Silica	
		Iron	
		Phosphate	
24	Measurement Range Silica :	Minimum 15 ppb	
	Measurement Range Iron :	Minimum 15 ppb	
	Measurement Range Phosphate :	Minimum 1 ppm	
25	Reagent Set	Minimum No of test:	
	Silica measurement :	50	
	Iron measurement :	50	
	Phosphate :	50	
26	Accessories (glass cuvettes, power supply cables, adapter etc) pertaining to measurement of above parameters should be included with the equipment.		

Note: - Apart from the above if any accessories is/are required for smooth operation of the Instrument has to be supplied by the Vendor.

3. Technical Specifications for supply of Pressure-Transmitters (PTs) & Differential Pressure-Transmitters (DPTs) with Manifolds and Hart-Communicators

3.1 Detailed technical specifications for Pressure transmitters(PTs):			
Sl. No.	Range	No. of items reqd./Set	Type
3.1.1	0 to 780 mm Hg	28	Absolute type
3.1.2	0 to 10 kg/cm ²	10	
3.1.3	0 to 25 kg/cm ²	8	Gauge type
3.1.4	0 to 100 kg/cm ²	15	
3.1.5	0 to 350 kg/cm ²	12	
3.1.6	Type	Smart Type	
3.1.7	Supply voltage	24V ± 5 Volts (DC)	
3.1.8	Out put	4-20 mA	
3.1.9	Accuracy:	± 0.075% of F.S. or better	
3.1.10	Wetted material	SS 316 or equivalent	
3.1.11	Operating Temp	0-60 °C	
3.1.12	Local Display	Not Required	
3.1.13	Zero & span adjustment	Provision of zero adjustment through Hart communicator. Further, provision of 10% Full-scale span adjustment.	
3.1.14	Proof/Bursting pressure	1.5 times of the full-scale value as specified above.	

3.1.15	Process connection required	The party has to provide the transmitters with suitable SS process - connection/adaptor of M 20 x 1.5 mm male.
3.1.16	Hart Communicator	One (01) no. universal hand held HART communicator to be supplied per set.
3.1.17	Manifold valve	Two-way SS Manifold valves (Inlet M20X1.5 mm male, Other end to be connected to Pressure Transmitter of M20x1.5mm male process connector/adaptor) to be supplied for each transmitter (<u>Drawing attached as Annexure-1</u>). The sample of manifold shall be approved by BHEL prior to full lot manufacturing and delivery.

3.2 Detailed technical specifications for Differential Pressure transmitters(DPTs):

Sl. No	Specifications			
3.2.1	Qty. Required/Set	3	4	3
3.2.2	Range Required	0-1.0 kg /cm ²	0-2.5 kg /cm ²	0-5 kg /cm ²
3.2.3	Static Pressure	300 kg/cm ²	300 kg/cm ²	300 kg/cm ²
3.2.4	Type	Smart Type		
3.2.5	Adjustable range from	0-0.2 kg /cm ² for full scale of 0-1.0 kg/cm ²	0-1.0 kg /cm ² for full scale of 0-2.5 kg/cm ²	0-1.0 kg /cm ² for full scale of 0-5 kg/cm ²
3.2.6	Loop voltage	24V ± 5V (DC)		
3.2.7	Local Display	Not Required		
3.2.8	Output	4-20 mA		
3.2.9	Operating Temp	0-60 °C		
3.2.10	Burst pressure	1.5 times static pressure		
3.2.11	Accuracy	± 0.05% of F.S. or better		
3.2.12	Zero & span adjustment	Provision of zero adjustment through Hart communicator. Further, provision of 10% Full-scale span adjustment.		
3.2.13	Process connection required	The party has to provide the transmitters with suitable SS process-connection/adaptor of M20x1.5mm male.		
3.2.14	Process wetted parts	316L SST or equivalent		
3.2.15	Flange	316 SST or equivalent for flange and adaptor bolts		
3.2.16	Manifold valve	Five-way SS Manifold valves ((Inlet M20X1.5 mm male, Other end to be connected to DP Transmitter of M20x1.5mm male process-connector/adaptor) to be supplied for each DP transmitter (<u>Drawing attached as Annexure-2</u>). The sample of manifold shall be approved by BHEL prior to full lot manufacturing and delivery.		
3.2.17	Additional fittings (suitable SS process connector) to be supplied (cost to be included in the main items as per the "unpriced price schedule" of the tender documents)	(1) 1/2" NPT to 1/4" ferrule based Male to male adaptor (100 No.) (2) 1/2" NPT to 1/2" M20X1.5 mm male to male adaptor (100 No.) (3) 1/4"NPT to 1/4" ferrule based Male to Male adapter(100 No.)		

SPECIAL TERMS AND CONDITIONS

1	Calibration certificates	<p>PT and DP transmitter: Minimum 05 points calibration certificate, up & down, to be supplied for each Pressure transmitter and Differential Pressure transmitter by the vendor from any accredited lab such as NABL/UKAS/NIST or National Laboratories of any country. Sample of required information on calibration certificate is attached as <u>Annexure –3</u>.</p> <p>Flue Gas Analyzer: The Vendor shall provide</p> <ul style="list-style-type: none"> • Calibration Certificate: Valid certificate from OEM/ NABL accredited Lab (Validity for at least 1 Year). • Operation Manual: - To be provided by Supplier/OEM in original (OEM COPY). • Certificate of NEWNESS to be provided by Supplier/OEM
---	---------------------------------	---

		<p>Spectrophotometer: The Vendor shall provide</p> <ul style="list-style-type: none"> • Calibration Certificate: Valid certificate from OEM/ NABL accredited Lab (Validity for at least 1 Year). • Operation Manual: - To be provided by Supplier/OEM in original (OEM COPY). • Certificate of NEWNESS to be provided by Supplier/OEM
2	Packing/carrying case	<p>PTs and DP transmitters: Transmitters connected with manifolds are to be supplied in properly packed hard (minimum of fibre body) portable carrying cases (maximum 04 no per carrying case) for trouble free transportation from site to site.</p> <p>Flue Gas Analyzer Refer to technical specification</p> <p>Spectrophotometer Refer to technical specification</p>
3	Delivery Period	<p>PT and DP transmitter a) SUPPLY (DELIVERY AND INSPECTION): Within Three (03) months from the date of PO. b) COMMISSIONING (INSTALLATION/ DEMONSTRATION / TRAINING): Within Two (02) Weeks from the date of Intimation from BHEL.</p> <p>Flue Gas Analyzer a) SUPPLY (DELIVERY AND INSPECTION): Within Eight (08) Weeks from the date of PO. b) COMMISSIONING (INSTALLATION, DEMONSTRATION AND TRAINING): Within Two (02) Weeks from the date of Intimation from BHEL.</p> <p>Spectrophotometer a) SUPPLY (DELIVERY AND INSPECTION): Within Eight (08) Weeks from the date of PO. b) COMMISSIONING (INSTALLATION, DEMONSTRATION AND TRAINING): Within Two (02) Weeks from the date of Intimation from BHEL.</p>
4	Inspection Requirement	<p>PT and DP transmitter Pre-dispatch inspection at supplier's work place.</p> <p>Not applicable for Flue Gas Analyzer and Spectrophotometer</p>
5	Inspection Notice	<p>PT and DP transmitter 10 Days in advance before dispatch of materials.</p> <p>Not applicable for Flue Gas Analyzer and Spectrophotometer</p>
6	Warrantee Conditions	<p>PT and DP transmitter Twelve (12) Months from the date of receipt at site. In case of malfunction of any PT/DPT during warrantee period, the supplier shall rectify/repair/replace the instrument and send to BHEL-PSER without any cost implication to BHEL.</p> <p>Flue Gas Analyzer To be provided by the supplier/OEM for Three (03) Years from the date of Commissioning or 3 Years 6 Months from date of Supply whichever is earlier.</p> <p>Spectrophotometer To be provided by the supplier/OEM for Three (03) Years from the date of Commissioning or 3 Years 6 Months from date of Supply whichever is earlier.</p>
7	Documents required along with materials	<ol style="list-style-type: none"> 1. GST Invoice 2. Warrantee Certificates 3. Calibration certificates of at least one-year validity 4. Certificate of newness 5. O&M instruction
8	Address for raising invoice (Bill to address)	BHEL-PSER, BHEL BHAWAN, DJ9/1, SECTOR-II, SALT LAKE CITY, KOLKATA-91. GST No. :19AAACB4146P1ZC
9	Address for delivery of consignment/ Consignee	AGM-TSX, BHEL-PSER, BHEL COMPLEX, 107/4A MANOHARPUKUR ROAD, KOLKATA-26.
पावर सेक्टर पूर्वी क्षेत्र (मुख्यालय) POWER SECTOR EASTERN REGION, DJ-9/1, SALT LAKE CITY, KOLKATA - 700 091 फैक्स/Fax: (033) 23211960 फोन/Phone: बोर्ड/EPABX: 23398220		Page - 27 of 37

10	TERMS OF PAYMENT	<p>1. 80% of Supply value excluding GST & BOCW Cess shall be payable within 60 days from the date of receipt of Tax Invoice along with Accessories, Calibration Certificate, Warranty/ Guarantee certificate, Consignment Note (if applicable), LR copy (if applicable), Endorsed Way Bill (if applicable), Receipt of Delivery Challan, Test Certificate, MDCC (if applicable), O&M Manual, Certificate of Newness, Circuit Diagram etc. certified by BHEL, as applicable.</p> <p>2. Balance 20% of Supply value plus 100% of Commissioning Charges excluding GST & BOCW Cess, as applicable shall be payable on submission of:</p> <p>i) Commissioning certificate issued by BHEL.</p> <p>ii) Performance Bank Guarantee (PBG) of 10% of total PO value in the prescribed format valid as per tendered PBG clause. The PBG confirmation charges shall be borne by vendor.</p> <p>iii) Above is subject to receipt of goods (Material Receipt Certificate-MRC) / service (Engineering Protocol) and tax invoice by BHEL thereof along with vendor declaring invoice in his return and paying GST within timeline prescribed for availing ITC by BHEL. GST along with any Interest if levied thereon for reasons elaborated in Tax clause of the tender which is not attributable to BHEL will be recovered from the Final Payment / Retention.</p> <p>Paying Authority: HEAD/FINANCE BHEL-PSER, KOLKATA.</p> <p>No advance shall be paid.</p> <p>Payment shall be made in INR only.</p> <p>All payment shall be paid through RTGS only. Successful bidder shall have to submit the requisite details in RTGS format.</p>
11	PVC, ORC & rate revision	Not Applicable
12	LIQUIDATED DAMAGE(LD)/PENALTY Delay in Delivery	<p>Subject to force majeure, If vendor fails to complete the job as per aforesaid supply/commissioning period, BHEL shall have the right to recover as penalty as below. Penalty on delay in supply and/or commissioning will be applicable to the delays attributed to vendor. Penalty will be considered separately for Supply & commissioning:</p> <p>a) The rate of penalty for delayed Supply shall be @0.5% per week of delay of total PO value (Supply + Commissioning) excluding GST & BOCW Cess as applicable in Supply subject to maximum of 10% of total PO value (Supply + Commissioning) excluding GST & BOCW Cess.</p> <p>b) The rate of penalty for delayed Commissioning shall be @0.5% per week of delay of total PO value (Supply + Commissioning) excluding GST & BOCW Cess as applicable in commissioning subject to maximum of 10% of total PO value (Supply + Commissioning) excluding GST & BOCW Cess.</p> <p>c) Maximum penalty for delay in Supply & Commissioning together shall be limited to 15% of total PO value (Supply & Commissioning) excluding GST & BOCW Cess as applicable.</p> <p>For purpose of penalty for delay in Supply of the equipment, the duration will be reckoned from the date of PO by BHEL.</p> <p>For purpose of penalty for delay in Commissioning of the equipment, the duration will be reckoned from the date of intimation by BHEL to vendor for readiness of site/equipment.</p>
13	Quantity Variation	Not applicable.
14	Evaluation Criteria	Evaluation shall be done on "Item Wise L1 basis on All Inclusive Total F.O.R Destination Price excluding GST & BOCW Cess" for SUPPLY & COMMISSIONING i.e. [(Total Basic Price for supply + Freight + Transit Insurance excluding GST & BOCW Cess) + (All-inclusive Total Commissioning Charges excluding GST & BOCW Cess)]"
15	Transit Insurance	TO BE BORNE BY VENDOR. Vendor to quote price including transit insurance cost. No additional claims above quoted price shall be entertained by BHEL.
16	Way Bill	To be arranged by Vendor

All Other terms and Condition as per GCC.

17	TAXES, DUTIES ETC
17.1	All taxes excluding GST (as specified elsewhere in this clause) & BOCW Cess (as specified elsewhere in the tender) but including, Charges, Royalties, any State or Central Levy and other taxes for materials if any obtained for the work and for execution of the contract shall be borne by successful bidder and shall not be payable extra by BHEL. Any increase of above at any stage during execution of contract, including extension of the contract, shall have to be borne by successful bidder contractor. Bidder's quoted/ accepted rates/ price shall be inclusive of all such requirements.
17.2	GST along with Cess (as applicable) legally leviable & payable by successful bidder as per GST Law shall be paid by BHEL, extra. Hence, bidder shall not include GST along with Cess (as applicable) in their quoted rates/ price.
17.3	Successful bidder shall furnish proof of GST registration with GSTN Portal covering the services under this contract. Registration should also bear endorsement for the premises from where the billing shall be done by successful bidder on BHEL for this project / work.
17.4	Since GST on output will be paid by BHEL separately as enumerated above, bidder's your quoted rates / price should be after considering the Input Credit under GST law at bidder's end.
17.5	TDS under Income Tax Act shall be deducted as per prevailing IT rules from the bills.
17.6	TDS under GST shall be deducted as per prevailing GST rules from the bills.
17.7.1	You may collect TCS under section 206C(1H) of Income Tax Act, 1961 if applicable.
17.7.2	In case, you collect TCS under section 206C(1H) of Income Tax Act, 1961, following compliance is required.
17.7.2.1	TAN and PAN of vendor should appear in all invoices/claims. Copy of TAN /TCS registration is to be submitted.
17.7.2.2	Amount of TCS and Assessable value on which TCS has been calculated should be specified clearly in the invoice.
17.7.2.3	You shall be required to submit certificate of TCS in Form no. 27D within 15 days from the due date for furnishing the statement of tax collected at the source.
17.7.3	In case, you do not collect TCS under section 206C(1H) of Income Tax Act, 1961, following declaration is to be submitted along with each invoice: - "I/We hereby declare that I/We are not required to collect TCS under section 206C(1H) of Income Tax Act, 1961, on this bill.
17.7.4	In event of failure to comply with the provisions of the Act, or proper certificate not issued, or if tax collected but not remitted to the Government, or for any other reason and thereby causing loss to BHEL, the same shall be recoverable from the vendor with applicable interest.
17.7.5	You shall comply with all statutory amendment/notifications in this respect.
17.8	Bidder shall note that GST Tax Invoice complying with GST Invoice Rules (Section 31 of GST Act & Rules referred thereunder) wherein the 'Bill To' details shall encompass following. BHEL GSTN – 19AAACB4146P1ZC NAME - BHARAT HEAVY ELECTRICALS LIMITED ADDRESS – BHEL Bhavan, DJ-9/1, Sector-II, Saltlake, Kolkata - 700091
17.9	Successful bidder to intimate immediately on the day of removal of goods (in case of any supply of goods) to BHEL along with all relevant details and send a scanned copy of Tax Invoice to BHEL through following communication mode for enabling BHEL to meet its GST related compliances. Portal address and Email address – Shall be intimated later. Specific details of above shall be intimated to successful bidder by BHEL at appropriate juncture.
17.10	In case of delay in submission of above mentioned documents on the date of dispatch, BHEL may incur penalty/ interest for not adhering to Invoicing Rules under GST Law. The same will be liable to be recovered from successful bidder, in case such delay is not attributable to BHEL.
17.11	In case of raising any Supplementary Tax Invoice (Debit / Credit Note), successful bidder shall issue the same containing all the details as referred to in Section 34 read with Section 31 of GST Act & Rules referred there under.
17.12	Successful bidder shall comply with the Time Limit prescribed under the GST Law and rules thereof for raising of the Tax Invoice. If any supply of goods is applicable, successful bidder shall also ensure prompt delivery of goods after dispatch.
17.13	Bidder shall note that in case GST credit is delayed / denied to BHEL due to delayed / non receipt of goods and / or Tax Invoice or expiry of the timeline prescribed in GST Law for availing such ITC, or any other reasons, not attributable to BHEL, GST amount shall be recoverable from successful bidder along with interest levied/ leviable on BHEL, as the case may be.
17.14	Successful bidder shall upload the invoices raised on BHEL in IFF/GSTR-1 within the prescribed time as given in the GST Act, and the same should be available to BHEL in FORM GSTR-2B electronically through the common portal; and confirmation of payment of such GST to the Government through filing of GSTR-3B of corresponding month/quarter. Bidder shall note that in case of delay in declaring such invoice in your return and GST credit availed by BHEL is denied or reversed subsequently as per GST Law, GST amount paid by BHEL towards such ITC reversal as per GST law shall be recoverable from the successful bidder along with interest levied / leviable on BHEL.
17.15	Successful bidder to arrange for e-waybill for any movement of goods for the execution of the contract. Successful bidder has to make their own arrangement at their cost for completing the formalities, if required, with Issuing Authorities, for bringing materials, plants & machinery at site for execution of the works under this contract, Road Permit / Way Bill, if required, shall be arranged by successful bidder and BHEL will not supply any Road Permit/ Way Bill for this purpose.
17.16	Any new taxes & duties, if imposed subsequent to due date of offer submission as per NIT & TCN, by statutory authority during contract period (including extension, if the same is not attributable to you), shall be reimbursed by BHEL on production of relevant supporting document to the satisfaction of BHEL. However, you shall obtain prior approval from BHEL before depositing new taxes and duties.
17.17	Benefits and / or abolition of all existing taxes must be passed on to BHEL against new taxes, if any, proposed to be introduced at a later date.

PART-E

PRICE SCHEDULE (UNPRICED) - VOLUME-III

PLEASE REFER
E-PROCUREMENT PORTAL <https://eprocurebhel.co.in>

PART-E

PRICE SCHEDULE - VOLUME-III

PLEASE REFER
E-PROCUREMENT PORTAL <https://eprocurebhel.co.in>

ABOVE TO BE READ ALONG WITH SCH-2
(WEIGHTAGE) OF PRICE SCHEDULE (VOLUME-III)

PART-H:
FORMS AND PROCEDURES

F-01

RTGS FORMAT

Form for getting payment through RTGS (Real Time Gross Settlement)

01. NAME OF VENDOR:
02. ADDRESS:
03. VENDOR'S BANK A/C NAME:
04. VENDOR'S BANK A/C NO.:
05. NAME OF BANK:
06. NAME OF BRANCH:
07. BRANCH PH. NO.:
08. CITY:
09. IFSC CODE OF THE BRANCH:

THE CHARGES IF ANY FOR PAYMENT THROUGH RTGS MAY BE RECOVERED FROM THE BILL SUBMITTED BY US.

SIGNATURE OF AUTHORISED
REPRESENTATIVE OF VENDOR WITH DATE
& SEAL

CONFIRMATION BY BANKER WITH
OFFICE SEAL

Note: Incorrect information will create accounting complications and payment will be delayed.

F-02

VENDOR DETAILS

- 1. Name & address of the vendor/company:**

- 2. PAN No. of the vendor/company (scan copy of PAN Card):**

- 3. Contact Person for the vendor/company:**

- 4. Mobile number & E-mail of the contact person:**

- 5. VAT / TIN:**

- 5. CST:**

SIGNATURE OF THE BIDDER WITH DATE & SEAL

F-03**FORMAT FOR DETAILS OF BIDDER**

NAME OF BIDDER	
FAX NO.	
Registration Number*	
Name of Partners / Directors	
Bidder Type Indian/ Foreign*	
City*	
State*	
Country*	
Postal Code*	
PAN/TAN Number*	
Company's Establishment Year	
Company's Nature of Business*	
Company's Legal Status* {limited company/ undertaking/joint venture/partnership/other}	
Company Category* {micro unit as per MSME/small unit as per MSME/medium unit as per MSME/Ancillary unit/project affected person of this company/ssi/ other}	
Enter Company's Contact Person Details Title(Mr. / Mrs. / Ms. / Dr. / Shri)*	
Contact Name*	
Date Of Birth*	
Correspondence Email* (Correspondence Email ID can be same as your Login ID. All the mail correspondence will be sent only to the Correspondence Email ID.)	
Designation	
Phone*	
Mobile*	

SIGNATURE OF THE BIDDER WITH DATE & SEAL

State wise GST Registration nos. of BHEL		
Sl. No.	State / UT	GST Reg. No.
1	Andhra Pradesh	37AAACB4146P7Z8
2	Assam	18AAACB4146P1ZE
3	Bihar	10AAACB4146P1ZU
4	Chandigarh	04AAACB4146P1ZN
5	Chattishgarh	22AAACB4146P1ZP
6	Daman & Diu	25AAACB4146P1ZJ
7	Delhi	07AAACB4146P1ZH
8	Gujarat	24AAACB4146P1ZL
9	Haryana	06AAACB4146P1ZJ
10	HP	02AAACB4146P1ZR
11	Jharkhand	20AAACB4146P5ZP
12	Karnataka	29AAACB4146P1ZB
13	Kerala	32AAACB4146P1ZO
14	Maharashtra	27AAACB4146P1ZF
15	MP	23AAACB4146P1ZN
16	Punjab	03AAACB4146P2ZO
17	Rajasthan	08AAACB4146P1ZF
18	Tamil Nadu	33AAACB4146P2ZL
19	Telangana	36AAACB4146P1ZG
20	Tripura	16AAACB4146P1ZI
21	UP	09AAACB4146P2ZC
22	Uttarakhand	05AAACB4146P1ZL
23	West Bengal	19AAACB4146P1ZC
24	Mizoram	15AAACB4146P1ZK
25	Orissa	21AAACB4146P1ZR
26	Arunachal Pradesh	12AAACB4146P1ZQ

LIST OF CONSORTIUM BANKS FOR BANK GUARANTEE



List of Consortium Banks *		
	Nationalised Banks	Nationalised Banks
1	Allahabad bank	19 Vijaya Bank
2	Andhra bank	Public Sector Banks
3	Bank of Baroda	20 IDBI
4	Canara Bank	Foreign banks
5	Corporation bank	21 CITI Bank N.A
6	Central bank	22 Deutsche Bank AG
7	Indian Bank	23 The Hongkong and Shanghai Banking Corporation Limited
8	Indian Oversea Bank	24 Standard Chartered Bank
9	Oriental bank of Commerce	25 J P Morgan
10	Punjab National Bank	
11	Punjab & Sindh Bank	Private banks
12	State Bank of India	26 Axis Bank
13	State Bank of Hyderabad	27 The Federal Bank Limited
14	Syndicate Bank	28 HDFC
15	State Bank of Travancore	29 Kotak Mahindra Bank
16	UCO Bank	30 ICICI
17	Union Bank of India	31 Indusind Bank
18	United Bank of India	32 Yes Bank

BHEL-PSER RTGS DETAILS

Form for getting payment through RTGS (Real Time Gross Settlement)

01. Name of Vendor **BHARAT HEAVY ELECTRICALS LTD.**
 02. Address **~~BHEL~~ BHEL HOUSE, SIRI FORT, N. DELHI**
 03. Vendors Bank A/c Name **BHARAT HEAVY ELECTRICALS LTD.**
 04. Vendors Bank A/c No. **11107800029**
 05. Name of Bank **STATE BANK OF INDIA**
 06. Name of Branch **COMMERCIAL BR., SALT LAKE, SECTOR-V**
 07. Branch Phone No. **KOLKATA**
033-23575666
 08. City **KOLKATA**
 09. IFSC Code of the Branch **SBIN0004289**

The charges if any for payment through RTGS may be recovered from the Bill submitted by us.

Signature of 
 के. के. कोआरी / K. K. Coari
 Representative of 
 उप महाप्रबंधक (वित्त) / Dy. General Manager (Fin)
 बी. एच. ई. एल. : पो. एस. ई. आर. : कोलकाता - 700 091
 BHEL: PSER / Kolkata-700 091

Confirmation by 
 with office seal 

Note : Incorrect information will create Accounting complications and payment will be delayed

Annexure-1

Two-way Manifold Drawing

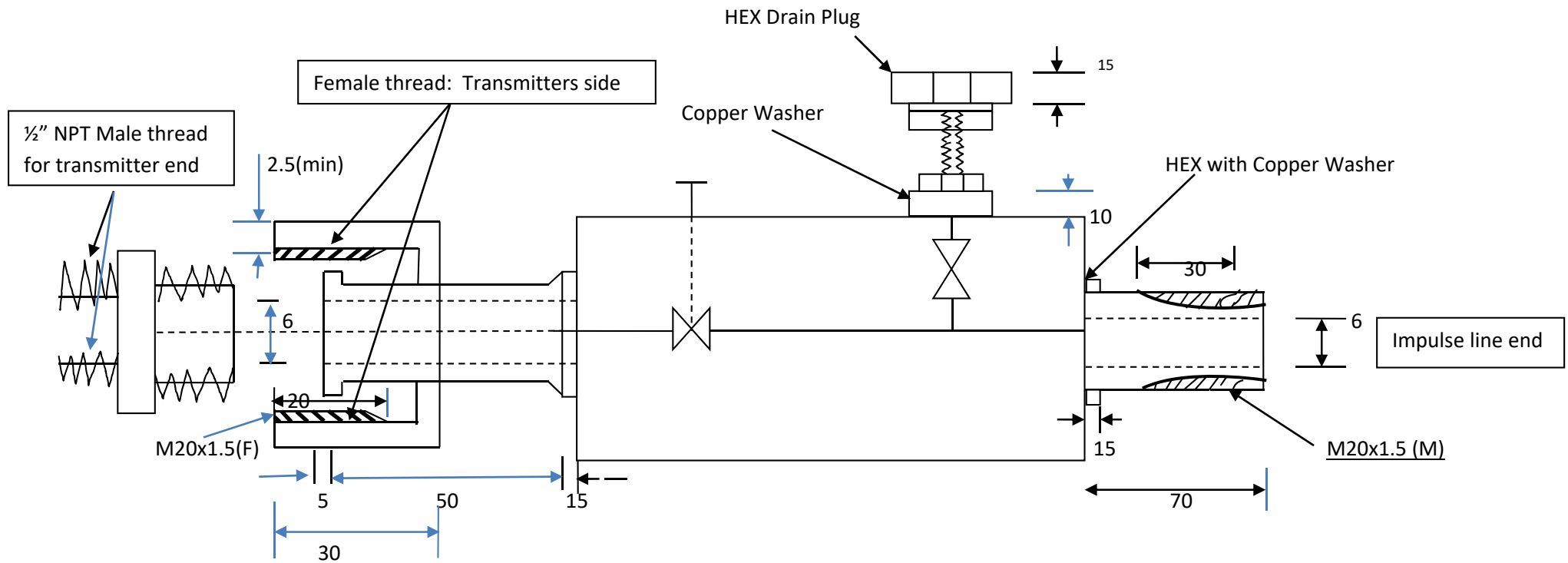

Dimensions in mm

Drawing not to scale

Five Manifold Drawing

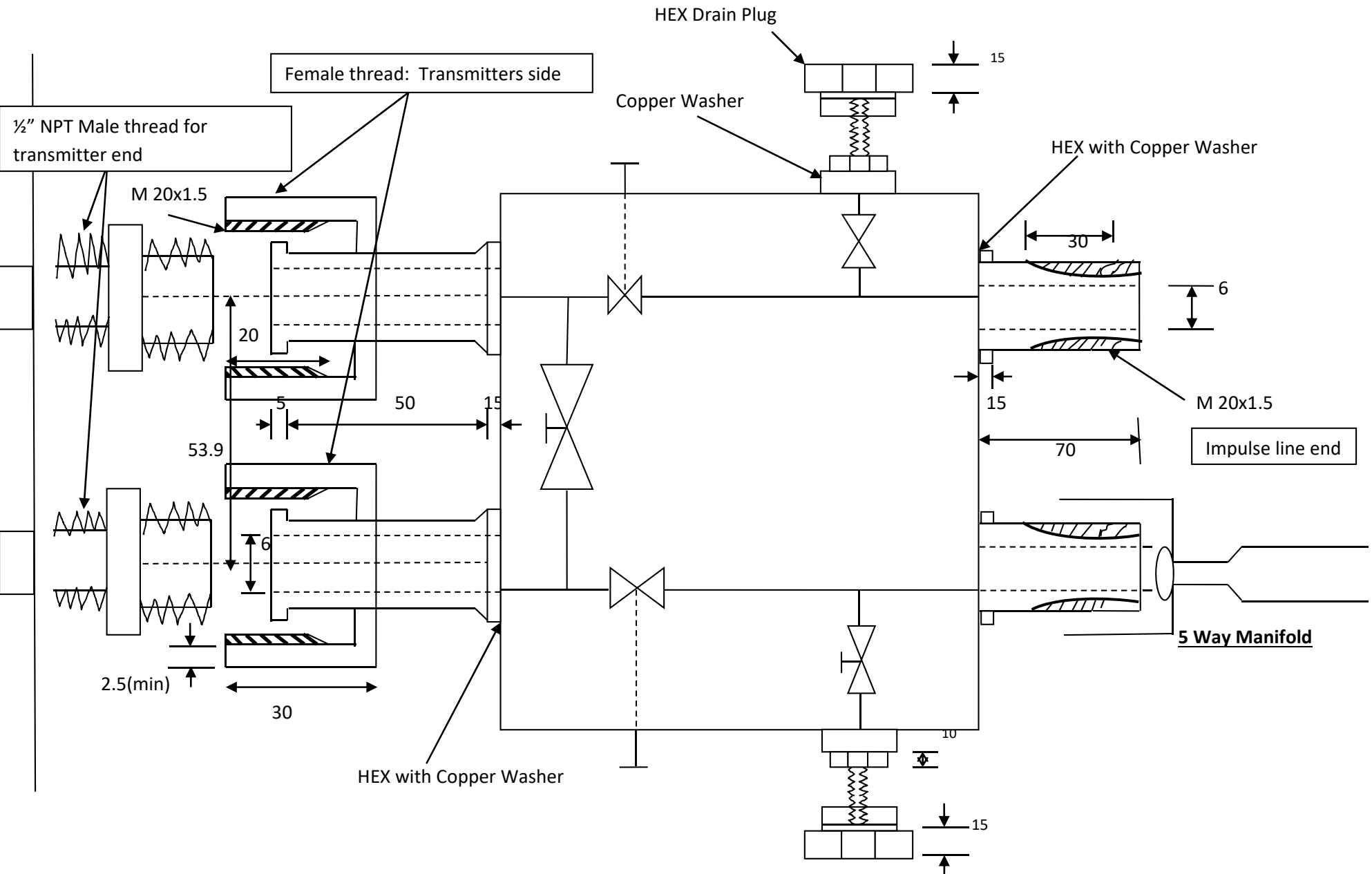

Dimensions in mm

Drawing not to scale

BANK GUARANTEE FOR PERFORMANCE SECURITY

Bank Guarantee No:

Date:

To

NAME

& ADDRESSES OF THE BENEFICIARY

Dear Sirs,

In consideration of the Bharat Heavy Electricals Limited (hereinafter referred to as the 'Employer' which expression shall unless repugnant to the context or meaning thereof, include its successors and permitted assigns) incorporated under the Companies Act, 1956 and having its registered office at BHEL House, Siri Fort, Asiad, New Delhi – 110049 through its Unit at Bharat Heavy Electricals Limited, Power Sector Eastern Region, BHEL Bhawan, Plot No 9/1, DJ Block, Sector-II, Salt lake City, Kolkata – 700091 having awarded to (Name of the Vendor / Contractor / Supplier) having its registered office at _____¹ hereinafter referred to as the 'Contractor/Supplier', which expression shall unless repugnant to the context or meaning thereof, include its successors and permitted assigns), a contract Ref No.....dated² valued at Rs.....² (Rupees -----)for <Nature of Work>³ (hereinafter called the 'Contract') and the Contractor having agreed to provide a Contract Performance Guarantee, equivalent to% (.... Percent) of the said value of the Contract to the Employer for the faithful performance of the Contract,

we,, (hereinafter referred to as the Bank), having registered/Head office at and inter alia a branch at being the Guarantor under this Guarantee, hereby, irrevocably and unconditionally undertake to forthwith and immediately pay to the Employer a maximum amount Rs ----- (Rupees -----)⁴ without any demur, immediately on a demand from the Employer, . Any such demand made on the Bank shall be conclusive as regards the amount due and payable by the Bank under this guarantee. However, our liability under this guarantee shall be restricted to an amount not exceeding Rs. _____.

We undertake to pay to the Employer any money so demanded notwithstanding any dispute or disputes raised by the Contractor/ Supplier in any suit or proceeding pending before any Court or Tribunal relating thereto our liability under this present being absolute and unequivocal.

The payment so made by us under this Guarantee shall be a valid discharge of our liability for payment thereunder and the contractors/supplier shall have no claim against us for making such payment.

We thebank further agree that the guarantee herein contained shall remain in full force and effect during the period that would be taken for the performance of the said Contract and that it shall

continue to be enforceable till all the dues of the Employer under or by virtue of the said Contract have been fully paid and its claims satisfied or discharged.

We BANK further agree with the Employer that the Employer shall have the fullest liberty without our consent and without affecting in any manner our obligations hereunder to vary any of the terms and conditions of the said Contract or to extend time of performance by the said Contractor/Supplier from time to time or to postpone for any time or from time to time any of the powers exercisable by the Employer against the said Contractor/Supplier and to forbear or enforce any of the terms and conditions relating to the said Agreement and we shall not be relieved from our liability by reason of any such variation, or extension being granted to the said Contractor/Supplier or for any forbearance, act or omission on the part of the Employer or any indulgence by the Employer to the said Contractor/Supplier or by any such matter or thing whatsoever which under the law relating to sureties would but for this provision have effect of so relieving us.

The Bank also agrees that the Employer at its option shall be entitled to enforce this Guarantee against the Bank as a principal debtor, in the first instance without proceeding against the Contractor and notwithstanding any security or other guarantee that the Employer may have in relation to the Contractor's liabilities.

This Guarantee shall remain in force upto and including.....⁵ and shall be extended from time to time for such period as may be desired by Employer.

This Guarantee shall not be determined or affected by liquidation or winding up, dissolution or change of constitution or insolvency of the Contractor/Supplier but shall in all respects and for all purposes be binding and operative until payment of all money payable to the Employer in terms thereof.

Unless a demand or claim under this guarantee is made on us in writing on or before the⁶ (3 months more than the present date of validity of Bank Guarantee) we shall be discharged from all liabilities under this guarantee thereafter.

We, BANK lastly undertake not to revoke this guarantee during its currency except with the previous consent of the Employer in writing.

Notwithstanding anything to the contrary contained hereinabove:

- a) The liability of the Bank under this Guarantee shall not exceed.....⁷
- b) This Guarantee shall be valid up to⁸
- c) Unless the Bank is served a written claim or demand on or before _____⁹ (3 months more than the present date of validity of Bank Guarantee) all rights under this guarantee shall be forfeited and the Bank shall be relieved and discharged from all liabilities under this guarantee irrespective of whether or not the original bank guarantee is returned to the Bank.

We, _____ Bank, have power to issue this Guarantee under law and the undersigned as a duly authorized person has full powers to sign this Guarantee on behalf of the Bank.

Any claim or dispute arising under the terms of this document shall only be enforced or settled in the courts of at Kolkata only.

For and on behalf of
(Name of the Bank)

Dated.....

Place of Issue.....

¹ NAME AND ADDRESS OF THE VENDOR /CONTRACTOR / SUPPLIER.

² DETAILS ABOUT THE NOTICE OF AWARD/CONTRACT REFERENCE

³ PROJECT/SUPPLY DETAILS

⁴ BG AMOUNT IN FIGURES AND WORDS

⁵ VALIDITY DATE

⁶ DATE OF EXPIRY OF CLAIM PERIOD

⁷ BG AMOUNT IN FIGURES AND WORDS.

⁸ VALIDITY DATE

⁹ DATE OF EXPIRY OF CLAIM PERIOD

Note:

1. Units are advised that expiry of claim period may be kept 2/3 months after validity date.

2. In Case of Bank Guarantees submitted by Foreign Vendors-

a. From Nationalized/Public Sector / Private Sector/ Foreign Banks (BG issued by Branches in India) can be accepted subject to the condition that the Bank Guarantee should be enforceable in the town/city or at nearest branch where the Unit is located i.e. Demand can be presented at the Branch located in the town/city or at nearest branch where the Unit is located.

b. From Foreign Banks (wherein Foreign Vendors intend to provide BG from local branch of the Vendor country's Bank)

b.1 In such cases, in the Tender Enquiry/ Contract itself, it may be clearly specified that Bank Guarantee issued by **any of the Consortium Banks only** will be accepted by BHEL. As such, Foreign Vendor needs to make necessary arrangements for issuance of Counter- Guarantee by Foreign Bank in favour of the Indian Bank (BHEL's Consortium Bank). It is advisable that all charges for issuance of Bank Guarantee/ counter- Guarantee should be borne by the Foreign Vendor. The tender stipulation should clearly specify these requirements.

b.2 In case, Foreign Vendors intend to provide BG from Overseas Branch of our Consortium Bank (e.g. if a BG is to be issued by SBI Frankfurt), the same is acceptable. However, the procedure at **sl.no. b.1** will required to be followed.

b.3 The BG issued may preferably be subject to Uniform Rules for Demand Guarantees (URDG) 758 (as amended from time to time). In case, of Foreign Vendors, the BG Format provided to them should clearly specify the same.

b.4 The BG should clearly specify that the demand or other document can be presented in electronic form.

PROFORMA OF BANK GUARANTEE (in lieu of SECURITY DEPOSIT)

In consideration of the Bharat Heavy Electricals Limited (hereinafter referred to as the 'Employer' which expression shall unless repugnant to the context or meaning thereof, include its successors and permitted assigns) incorporated under the Companies Act, 1956 and having its registered office at BHEL House, Siri Fort, Asiad, New Delhi – 110049 through its Unit at Bharat Heavy Electricals Limited, Power Sector Eastern Region, BHEL Bhawan, Plot No 9/1, DJ Block, Sector-II, Salt lake City, Kolkata – 700091 having agreed to exempt **(Name of the Vendor / Contractor / Supplier)** having its registered office at _____¹ (hereinafter called the said Contractor which term includes supplier), from demand under the terms and conditions of the Contract reference No. _____² dated _____² valued at Rs.....² (Rupees -----)² for <Nature of the Work>³ (hereinafter called the said Contract) of Security Deposit for the due fulfilment by the said contractor of the terms and conditions contained in the said Contract, on production of a Bank Guarantee for Rs. _____⁴ (Rupees _____ only), we _____(indicate the name and address of the Bank) having its Head Office at _____(address of the head Office) (hereinafter referred to as the Bank) at the request of _____ [Name of Contractor(s)] do hereby undertake to pay to the Employer an amount not exceeding Rs. _____ in the event of any breach by the said Contractor(s) of any of the terms and conditions contained in the said Contract.

We, _____(indicate the name of the Bank), do hereby undertake to pay the amounts due and payable under this guarantee without any demur, merely on a demand from the Employer. Any such demand made on the bank, shall be conclusive as regards the amount due and payable by the Bank under this guarantee. However, our liability under this guarantee shall be restricted to an amount not exceeding Rs. _____.

We undertake to pay to the Employer any money so demanded notwithstanding any dispute or disputes raised by the Contractor(s) in any suit or proceeding pending before any Court or Tribunal relating thereto our liability under this present being absolute and unequivocal.

The payment so made by us under this guarantee shall be a valid discharge of our liability for payment hereunder and the Contractor(s) shall have no claim against us for making such payment.

We, further agree that the guarantee herein contained shall remain in full force and effect during the period that would be taken for the performance of the said Contract and that it shall continue to be enforceable till all the dues of the Employer under or by virtue of the said Contract have been fully paid and its claim satisfied or discharged or till _____⁵ or till the office/Department/Division of Bharat Heavy Electricals Limited certifies that the terms and conditions of the said Contract have been fully and properly carried out by the said contractor(s) and also including the satisfactory performance of the equipment during guarantee period and accordingly discharges this guarantee. Unless a demand or claim under this guarantee is made on us in writing on or before the _____⁶, (3 months more than the present date of validity of Bank Guarantee) we shall be discharged from all the liability under this guarantee thereafter.

We, _____(indicate the name of the Bank)_____ further agree with the Employer that the Employer shall have the fullest liberty without our consent and without affecting in any manner our obligations hereunder to vary any of the terms and conditions of the said Contract or to extend time of performance by the said contractor(s) from time to time or to postpone for any time or from time to time any of the powers exercisable by the Employer against the said contractor(s) and to forbear or enforce any of the terms and conditions relating to the said Contract and we shall not be relieved from our liability by any reason of any such variation or extension being granted to the said contractor(s) or for any forbearance, act or omission on the part of the Employer or any indulgence by the Employer to the said contractor(s) or by any such matter or thing whatsoever which under the law relating to sureties would but for this provision have effect of so relieving us.

This guarantee will not be discharged due to the change in the constitution of the Bank or the Contractor(s).

We,..... BANK lastly undertake not to revoke this guarantee during its currency except with the previous consent of the Employer in writing.

Notwithstanding anything to the contrary contained hereinabove:

- a) The liability of the Bank under this Guarantee shall not exceed.....⁷
- b) This Guarantee shall be valid up to⁸
- c) Unless the Bank is served a written claim or demand on or before _____⁹ (3 months more than the present date of validity of Bank Guarantee) all rights under this guarantee shall be forfeited and the Bank shall be relieved and discharged from all liabilities under this guarantee irrespective of whether or not the original bank guarantee is returned to the Bank.

We, _____(indicate the name of the Bank)_____ lastly undertake not to revoke this guarantee during its currency except with the previous consent of the Employer in writing.

Any claim or dispute arising under the terms of this document shall only be enforced or settled in the courts of at Kolkata only.

Date _____ Day of _____
for _____ (indicate the name of the Bank) _____

(Signature of Authorised signatory)

¹ NAME AND ADDRESS OF THE VENDOR /CONTRACTOR / SUPPLIER .

² DETAILS ABOUT THE NOTICE OF AWARD/CONTRACT REFERENCE

³ PROJECT/SUPPLY DETAILS

⁴ BG AMOUNT IN FIGURES AND WORDS

⁵ VALIDITY DATE

⁶ DATE OF EXPIRY OF CLAIM PERIOD

⁷ BG AMOUNT IN FIGURES AND WORDS.

⁸ VALIDITY DATE

⁹ DATE OF EXPIRY OF CLAIM PERIOD

Note:

1. Units are advised that expiry of claim period may be kept 2/3 months after validity date.

2. In Case of Bank Guarantees submitted by Foreign Vendors-

- a. **From Nationalized/Public Sector / Private Sector/ Foreign Banks (BG issued by Branches in India)** can be accepted subject to the condition that the Bank Guarantee should be enforceable in the town/city or at nearest branch where the Unit is located i.e. Demand can be presented at the Branch located in the town/city or at nearest branch where the Unit is located.
- b. **From Foreign Banks (wherein Foreign Vendors intend to provide BG from local branch of the Vendor country's Bank)**
 - b.1 In such cases, in the Tender Enquiry/ Contract itself, it may be clearly specified that Bank Guarantee issued by **any of the Consortium Banks only** will be accepted by BHEL. As such, Foreign Vendor needs to make necessary arrangements for issuance of Counter-Guarantee by Foreign Bank in favour of the Indian Bank (BHEL's Consortium Bank). It is advisable that all charges for issuance of Bank Guarantee/ counter- Guarantee should be borne by the Foreign Vendor. The tender stipulation should clearly specify these requirements.

- b.2** In case, Foreign Vendors intend to provide BG from Overseas Branch of our Consortium Bank (e.g. if a BG is to be issued by SBI Frankfurt), the same is acceptable. However, the procedure at **sl.no. b.1** will required to be followed.
- b.3** The BG issued may preferably be subject to Uniform Rules for Demand Guarantees (URDG) 758 (as amended from time to time). In case, of Foreign Vendors, the BG Format provided to them should clearly specify the same.
- b.4** The BG should clearly specify that the demand or other document can be presented in electronic form.