



# Bharat Heavy Electricals Limited

## Heavy Equipment Repair Plant

Tarna Shivpur Varanasi-221003

website: <https://herp.bhel.com>

### ENQUIRY

To

ENQUIRY THROUGH E-PROCUREMENT : **NO**

Enquiry Number : **E-588-23-0010-69-1** Date : **12/Oct/2023**

Tender Opening Date : **26/Oct/2023**

#### Enquiry For Material :-

SI No	Material Code	Material Description	Quantity	Unit	Delivery Schedule
1	RVA210700001	SUPPLY , INSTALLATION & COMMISSIONING OF CENTRIFUGAL CASTING MACHINE AS PER ANNEXURE-A.	1.0	SET	30.09.2024 ( 1 SET )

#### Remarks

1. DELIVERY, INSTALLATION & COMMISSIONING PERIOD, WARRANTY: AS PER CLAUSE 16 OF ANNEXURE-A.
2. JOB PROVE OUT REQUIREMENT : REFER CLAUSE 6 OF ANNEXURE-A
3. PRE DISPATCH INSPECTION:-AS PER CLASUE 7 & 11 OF THE ANNEXURE-A.
4. CIVIL WORK FOR FOUNDATION SHALL BE IN SCOPE OF BHEL. VENDOR SHOULD SUBMIT DETAILS AS PER CLAUSE 8 of ANNEXURE-A.
5. TECHNICAL SPECIFICATION CUM COMPLIANCE CERTIFICATION FOR CENTRIFUGAL CASTING MACHINE 2500 Kgs CAPACITY AS PER ANNEXURE-A .
6. BHEL PRE-QUALIFYING REQUIREMENT ANNEXURE-B.
7. JOB PROVE OUT DRAWING- ANNEXURE-C.
7. UN PRICED PRICE BID FORMAT FOR FOREIGN AND DOMESTIC BIDDERS.
9. WHITE METAL SPECIFICATION AS PER ANNEXURE-D.
- 10.SPECIFICATION FOR NDT AS PER ANNEXURE-E.
11. ALL OTHER TERMS AND CONDITIONS WILL BE AS PER ANNEXURE-Z. THIS ANNEXURE-Z IS A PART OF THIS ENQUIRY AND SIGNED AND STAMPED COPY IS TO BE SENT ALONG WITH OFFER.THE TERMS MENTIONED IN THE ANNEXURE-Z ARE FINAL AND ARE TO BE ADHERED TO.
12. OFFERS CAN BE SUBMITTED THROUGH EMAIL ID (TENDERHERP@BHEL.IN) OR THROUGH HARD COPY ONLY. THE DETAILS CAN BE SEEN IN ANNEXURE-Z POINT NO 1.

Dear Sirs,

Please submit quotation, subject to our terms and condition overleaf, for the above materials ,so as to reach us on or before the due date by 11-00 hours .

(1) Important : Please see clause 4 & 12 on overleaf terms & condition sheet , for strict compliance .

(2) In case you are not making an offer against this enquiry we request you to mail a regret .

(3) Please indicate the tariff item no. and rate of excise duty applicable .

(4) Your quotation must be valid for atleast 90 days from the date of opening .

(Executive - Purchase Department)



**TECHNICAL SPECIFICATION CUM COMPLIANCE CERTIFICATION FOR CENTRIFUGAL CASTING MACHINE 2500 Kgs CAPACITY AS PER ANNEXURE-A**

Heavy Equipment Repair Plant,  
Bharat Heavy Electricals Limited,  
Varanasi -221003, Uttar Pradesh, INDIA.

Enquiry No. & Dt.:  
Supplier's Ref.:  
Date :

GTE:Specification cum Compliance Certificate for 'CENTRIFUGAL CASTING MACHINE FOR BABBITTING OF TG BEARINGS UPTO OD: 1030 mm WEIGHT 2500 kgs WITH MOUNTING FIXTURES'.

**NOTES:**

- The Column "VENDOR'S OFFER WITH TECHNICAL DETAILS & REMARKS" of this format shall be filled in by the Vendor and submitted along with the offer. Inadequate / incomplete, ambiguous or unsustainable information against any of the clauses of the specifications / requirements shall be treated as non-compliance.
- The offer and all documents enclosed with offer should be in English language only.
- Total No of Machines = 1

Name & Address of the supplier:

Telephone No.

Fax No.

e-mail :

**Annexures for Reference:**

Engineering drawings for job prove out	Annexure-C	Total pages:19 pages
White metals as per specification HW 12897	Annexure-D	Total pages: 03 pages
NDT SPECIFICATION- HW0850195	Annexure-E	Total pages: 11 pages

**Timeline for important Activity after placement of PO:**

1	Information regarding final selection of for job prove out shall be as per availability of casting/Shell and will be confirmed to vendor within 60 days of placement of PO by BHEL
2	Foundation & layout drawings shall be submitted by the successful bidder within 60 days after placement of PO
3	Delivery Installation Commissioning Schedule as per Clause 17
4	Schedule for PDI as per clause 7

**Scope: Supply, Erection & Commissioning of Centrifugal casting machine complying with specification as below.**

SL NO.	BHEL TECHNICAL SPECIFICATION	VENDOR REMARK
1	<b>PURPOSE &amp; WORK PIECE MATERIAL</b>	
	<b>PURPOSE/APPLICATION:</b> Proposed Centrifugal casting Machine is required for centrifugal casting of white metal (BABBITT) in Journal bearings of OD upto 1030 mm & final weight 2500 kgs including mounting fixtures.	Vendor to confirm
	The centrifugal casting machine should be specifically designed to safely and economically cast white metal (babbit) into ferrous or nonferrous housings in the form of bushes, bearings, half shells and shaped shells, using white metals as per specification HW 12897 attached as Annexure-D	Vendor to confirm
2	<b>SPECIFICATION:</b>	
2.1	<b>MACHINE CONFIGURATION:</b>	Vendor to confirm
2.1.1	<b>HEAD STOCK</b>	
2.1.1.1	Face Plate diameter	1200 mm or more
2.1.1.2	Power of Main motor	30 KW or above
2.1.1.3	Main motor for Head stock Make, model of Siemens/ ABB/CG/ALSTOM or equivalent Make Asynchronous motor	Vendor to submit details.
2.1.1.4	Spindle speed (Infinitely variable)	0-600 rpm
2.1.1.5	No. of speed ranges-	Vendor to submit details
2.1.1.6	Drive mechanism	Vendor to submit details
2.1.1.7	Torque-Power-Speed characteristics of the spindle system to be submitted by the vendor.	Vendor to submit details
2.1.1.8	Main bearings of drive end faceplate & driven faceplate shall be life time lubricated/selaed	Vendor to submit details
2.1.1.9	Both faceplate bearing should be of Make INA/FAFNIR/RHP/FAG/SKF/TIMKEN ONLY	Vendor to submit details
2.1.1.10	Bidder to submit Make & type of both bearings mentioned above	Make INA/FAFNIR/RHP/FAG/SKF/ TIMKEN ONLY
2.1.1.11	Maximum holding OD for largest size bearing	1030 mm or more

## 1726146/2023/HERP-MAINT

2.1.1.12	Maximum distance between face plates	800 mm or more	
2.1.1.13	Maximum bearing length	750 mm or more	
2.1.1.14	Minimum OD diameter for holding onto faceplate	200 mm or less	
2.1.1.15	Minimum inside diameter suitable for babbiting	150 mm or less	
2.1.1.16	Weight of mounting fixtures for bearing of OD 1030mm, ID 530 mm Length 530 mm & weight 1500-1600 kgs ( Refer Drawing No- 0-11836-58000).	Vendor to submit details	
2.1.2	<b>FEED DRIVE SYSTEM, HMI, PLC &amp; MOTORS</b>		
2.1.2.1	VVVF Make & rating for the main motor	Vendor to offer VVVF of Siemens/ ABB/ALLEN	
2.1.2.2	Chuck/ face plate holding arrangement with details of PCD	Vendor to submit details	
2.1.2.3	Details of mechanism for braking and braking time	Vendor to submit details	
2.1.2.4	Make & model of Spindle motor	Siemens or equivalent	
2.1.2.5	Make & model for Hydraulic motor	Siemens or equivalent	
2.1.2.6	Make & model for motorized guard motor	Siemens or equivalent	
2.1.2.7	Make & model of PLC	Siemens make only	
2.1.2.8	Make and model of HMI	Siemens make only	
2.1.2.9	RPM display through encoder or Inverter paramaters and preferably through rotary encoder.	Vendor to submit details	
2.2	<b>CONSTRUCTION:</b>		
2.2.1	Base frame: Fabricated, fully welded and machined heavy duty rectangular hollow section, selected for its rigidity and strength. The base unit should fully support the drive and traversing head.	Vendor to submit	
2.2.2	Drive head: The drive head should be designed as a single heavy fabricated box frame fully machined to support the drive shaft and support bearings. The frame should be rigid enough to reduce vibration allowing for smooth operation. All bearings should be grease lubricated. Necessary braking arrangement should be available for chuck.	Vendor to submit	
2.2.3	Traversing head: The traversing head should be designed to allow pouring of the Babbitt or whit metal material.	Vendor to submit	
2.2.4	Traversing head Support: The traversing head should be designed to clamp the production bearing shell. The movement of the traversing head should be controlled by two hydraulic cylinders giving precise control and smooth operation. The hydraulic cylinders are to be mounted as close to the centreline of the faceplate to facilitate even clamping and pressure	Vendor to submit	
2.2.5	Clamping system should be hydraulic with three safety systems to prevent ejection of the bearing during production. 1. P.O. check valves in case of hose failure 2. A pre-charged accumulator to maintain pressure in case of power failure. 3. Twin cylinders so if one fails pressure is maintained.	Vendor to submit	
2.2.6	Faceplates (02 Nos.) to be attached to the drive head and traversing head shafts. The face plates to be precision machined with heavy duty application, with drilled and tapped holes on various P.C.D. to allow fixing of the bearing shell locators(dogs) to facilitate ease of centering of the bearing shell during production.	Vendor to submit	
2.2.7	Main Drive required as per standard IEC general purpose motor with IE2/IE3 efficiency to provide infinitely variable speed operating on the frequency operating and adjustment principle.	Vendor to submit	
2.2.8	Motorised MS/SS Guarding: All guards are fully interlocked to prevent machine operation when open.	Vendor to submit	
2.2.9	Water Cooling & Circulating: A water-cooling system is required as standard, housed within the main guard the cooling system can be made up of more than one bank of nozzles dependent on machine size for minimum 200 litres per min water flow. Nozzles required to be turned on or off to suit the bearing configuration through PLC. The water cooling should be controlled via the PLC and HMI to provide controlled cooling to improve the bonding of the white metal/ Babbitt to the shell.	Vendor to submit	
2.2.10	Pouring A stainless steel fabricated 2 part pouring funnel/ bucket and spout required on rails to allow for ease of movement between pouring and pre-heating position. The pouring funnel shall be suitable for pre-heating.	Vendor to submit	
2.3	<b>OPERATION AND CONTROL SYSTEM:</b>		
2.3.1	<b>OPERATOR'S PANEL:</b>		

## 1726146/2023/HERP-MAINT

2.3.1.1	Swiveling type operator's panel/desk mounted system having complete machine control system with display monitor HMI of required configuration shall be provided on the Operators Platform. All switches on the Operator's panel including that for table rotation should be within reach of operator of average Indian height for convenient, efficient & safe operation. All displays/indications should also be conveniently placed accordingly. Layout showing complete details of the panel should be submitted.	Vendor to submit details	
2.3.2	<b>MANUAL CONTROL</b>		
	Complete manual control of machine with required switches / keys should be provided on operator's panel for setting RPM, controlling water cooling jets, automatic opening/closing of motorised guard, clamping using faceplate, hydraulic controls, Alarm/ fault indication. Diagram / Sketches for switches / keys provided on operators pendant should be submitted.	Vendor to confirm. Layout of panel showing requisite switches to be submitted.	
2.4	<b>DIAGNOSTIC SYSTEMS</b>		
2.4.1	HMI with alarm messaging, pictorial display & recipe functionality	Vendor to provide details	
2.4.2	Thermocouple for Display of inner ID/ OD temperature and interlocking with program/ operation of machine	Vendor to provide details & confirm	
2.5	<b>AIR CONDITIONERS</b>		
2.5.1	Independent air conditioners of suitable capacity to be provided for Electrical Panel considering specified ambient conditions. Detailed specifications of the same are to be submitted. Make: RITTAL or equivalent	Vendor to offer & confirm	
2.6	<b>HYDRAULIC SYSTEM</b>		
2.6.1	The Hydraulic System shall be of Re-Circulating Type. Hydraulic Tank should be preferably placed at shop floor.	Vendor to offer and confirm	
2.6.2	Pumps, Valves, Switches (Pressure & Flow) should be of Make: Rexroth / Vickers/Parker/Hawe or equivalent	Vendor to offer and confirm	
2.6.3	Filtration System: Sufficient no. of filters (with electric clogging indicator and alarm on PLC) should be used to avoid frequent clogging of the filters and other maintenance related problems.	Vendor to offer and confirm	
2.6.4	Failure indication through LED and indication in HMI	Vendor to offer	
2.6.5	Automatic shut off provision, Details should be submitted.	Vendor to offer	
2.6.6	Refrigerated/Air Cooled type cooling system of sufficient capacity to maintain complete Hydraulic System keeping in view the specified ambient conditions to be offered with complete details. The temperature of Hydraulic Oil should not go beyond 10 degrees above ambient i.e 32 deg+10 deg= 42. C.		
2.6.7	Hydraulic pump & cylinder capacity (flow / pressure) Make: Duplomatic/Bosch/Rexroth/HAWE or equivalent	Vendor to inform	
2.6.8	Vendor to provide details of power pack, motor pump rating, clamping pressure & working pressure details.	Vendor to confirm	
2.6.9	Sufficient stages/nos. of filters should be used to avoid frequent clogging of the filters and other maintenance related problems.	Vendor to offer	
3	<b>ACCESSORIES:</b>		
3.1	White metal holding (Electric) furnace , manual type, fixed body/Tilting type, capacity dia 400 x 400 mm ( Nominal 350 Kg-500 kg)	Vendor to provide details	
3.2	Bottom pour Ladle of 200 kg or more	Vendor to provide details	
3.3	Melting station with 2 Gas burners and complete with Gas control valves	Vendor to provide details	
3.4	Bearing shell pre heat with Burner with stand & accessories	Vendor to provide details	
3.5	Pouring spout pre heat burner with temperature indication	Vendor to confirm	
3.6	Tinning Bath (Electric) 1200mm x 1000mm x 800mm deep (approx) or higher size, Complete with Energy and Temperature Controls suitable for bearing.	Vendor to offer	
3.7	Clamps/guides for centring bearing between faceplates during job prove out	Vendor to offer	
4	<b>ELECTRICAL :</b>		
	415V + 10% / -10%, 50 Hz +/-3 Hz, 3 Phase AC (3 wire system without Neutral) Power Supply will be provided by BHEL at a single point near the machine, as per layout recommended by Vendor. All types of switches, cables, connections, circuit breakers etc. required for connecting BHEL's power supply point to different parts of the machine/control cabinets including shall be supplied by the vendor.	Vendor to offer	
5	<b>SAFETY ARRANGEMENTS</b>	Vendor to offer	
5.1	Machine should have adequate and reliable safety interlocks / devices to avoid damage to the machine, work piece and the operator due to the malfunctioning or mistakes. Machine functions should be continuously monitored and alarm/ warning indications through lights/ alarm number with messages (on HMI display) should be available.	Vendor to offer	

## 1726146/2023/HERP-MAINT

5.2	A detailed list of all alarms / indications provided on machine should be submitted by the supplier.	Vendor to submit	
5.3	All the pipes, cables etc. on the machine should be well supported and protected. These should not create any hindrance to machine operator's movement for effective use of machine.	Vendor to offer	
5.4	All the rotating parts used on machine should be statically & dynamically balanced to avoid undue vibrations & noise.	Vendor to confirm	
5.5	Emergency Switches at suitable locations as per International Norms should be provided.	Vendor to offer	
5.6	Oil & water pipe lines should not run with electrical cable in the same trench.	Vendor to offer	
5.7	Power/hose failure hydraulic safety system	Vendor to offer	
5.8	Fail-safe clamping control.	Vendor to offer	
5.9	Dual system/ set of cylinders, check valves	Vendor to offer	
5.1	Electrically interlocked guards to prevent opening during rotation	Vendor to offer	
5.11	Motorised guarding with safety interlocks	Vendor to offer	
5.12	Faceplate lock interlock to prevent accidental operation	Vendor to offer	
5.13	Dual faceplate open/close control to prevent accidental operation of controls	Vendor to offer	
5.14	Accumulator to maintain pressure during power failure	Vendor to provide pressure and capacity in litres	
5.15	Interlocking to ensure safety in operation of hood, spindle, clamping, hydraulic pressure etc	Vendor to offer	
	<b>PROVE-OUT MACHINING OF BHEL COMPONENT ON MACHINE AT HERP DURING COMMISSIONING</b>	Vendor to offer	
	Maximum four components out of jobs mentioned under shall be offered for job prove out having OD 400-1030 mm & bearing weigh upto 2500 Kg (without clamping fixture) as per Annexure-C (detailed under) . Information regarding final selection of for job prove out shall be as per availability of casting/Shell and will be confirmed to vendor within 60 days of placement of PO by BHEL . (Also refer Annexure C,D,E).		
	<b>Drawing 01</b>		
	Component Name: Journal bearing 530x530		
	Machining Drawing : 01183658000		
	Forging Drawing : 21183658999		
	Raw Material : Low alloy steel forging		
	<b>Drawing 02</b>		
6	Component Name: Journal bearing 450 x 425 mm	Vendor to accept & offer	
	Machining Drawing : 11814-18000		
	Ref No- HW 297.41/ RB092.00		
	Raw Material : Low alloy steel forging		
	<b>Drawing 03</b>		
	Component Name: Liner		
	Machining Drawing : 2-11703-27110		
	Ref No- HW 165.25		
	Raw Material : Low alloy steel forging		
	<b>Drawing 04</b>		
	Component Name: Journal bearing 500 x 450		
	Machining Drawing : 011814-02000		
	Ref No- HW 165.27		
	Raw Material : Low alloy steel forging		
7	<b>TRAINING &amp; PRE-DISPATCH INSPECTION :</b>		
	Two/Three BHEL Persons should be trained at vendor's works for the area & period given below for 1 week at OEMs work: (a) Process & programming for the machine, measuring system, etc. (b) Maintenance of machine & other supplied equipment (c) Operation & production.		
	Pre-dispatch inspection of the machine shall also be carried out by the team during their stay at OEM/ ANY PARTNER OF JOINT BIDDING for the training in above specified period ( as per details submitted by the bidder along with offer). BHEL reserves the right to choose no. of persons & period of training while deputing their engineers. BHEL may also waive off the requirement of PDI before dispatch subject to its own discretion (in such case supplier shall arrange for ONLINE PDI / Third party inspection as per BHEL requirement/specification)	Vendor to confirm and provided address for Pre dispatch Inspection.	
7.1	For PDI outside India: Call for PDI shall be given atleast 45 days in advance for travel documentation and other requirements. For PDI within India: Call for PDI shall be given atleast 15 days in advance for travel documentation and other requirements.		

## 1726146/2023/HERP-MAINT

7.2	Air/train-fare, boarding & lodging for the trainees shall be borne by BHEL.	For vendor's information.	
7.3	Competent, English speaking experts shall be arranged by the vendor for satisfactory & effective training of BHEL personnel.	Vendor to accept & confirm	
8	<b>FOUNDATION</b>		
	Vendor shall submit the preliminary General Arrangement Drawing & Layout Drawing for getting BHEL's approval within 30 days from the date of Letter of Intent (LOI) / P.O. Complete Foundation details viz. static / dynamic load details etc. and Final Layout drawings shall be submitted by the supplier within 60 days after placement of PO. The layout should consist of all requirements pertaining to complete machine including space requirement for Voltage Stabilizer, Isolation Transformer, Air compressor, & all other accessories/ attachments/ offered items. BHEL shall design & construct complete foundation for the machine as per Final Layout & other details provided by vendor. The vendor shall also indicate detailed specifications of grouting compound and grouting procedure etc. if any specifically desired for foundation bolts of the machine. ( <b>Supply of Voltage Stabilizer, Isolation Transformer/ Air compressor shall be in scope of BHEL</b> ).	Vendor to accept & offer	
9	<b>ERECTION &amp; COMMISSIONING</b>		
9.1	Supplier to take full responsibility for carrying out the start up, testing of machine, it's control system & all types of other supplied equipment, job prove out etc.		
9.2	Service requirement like power, air & water shall be provided by BHEL at only one point to be indicated by supplier in their foundation/layout drawings. Other requirements like crane and helping personnel shall also be provided by BHEL. Details of these requirements should be informed by vendor in advance. The available crane capacity at the proposed location of the machine will be 75 Ton. The vendor will ensure to make requisite arrangement for lifting of heavier consignment/ items/ assembly of the machine not getting covered by this capacity.	Vendor to accept.	
9.3	Bidder may specify requirement of surface preparation in terms of roughness value necessary during job prove out during installation & commissioning of the machine.	Vendor to offer	
9.4	Successful proving of BHEL components by the supplier shall be considered as part of commissioning for the machine. All tests, as mentioned at Sl. No. 6, 11 & 12 (Machine Acceptance) shall also be part of the commissioning activity.	Vendor to offer	
9.5	Tools, Tackels, Test Mandrels, instruments and other necessary equipment including Laser equipment required to carry out all erection & commissioning activities should be arranged and brought by the supplier.	Vendor to accept	
9.6	Commissioning spares, required for commissioning of the machine within stipulated time, shall be brought by the supplier on returnable basis.	Vendor to accept	
9.7	Schedule of Erection and Commissioning shall be submitted with the offer.	Vendor to submit	
9.8	Terms & conditions for Erection & Commissioning should be furnished in detail separately by vendor along with offer.	Vendor to submit	
9.9	Portion, if any, of the machine, accessories/attachments and other supplied items where paint got rubbed or peeled off during transit or erection should be re-painted and matched with the original adjoining paint by the vendor. For this purpose, the vendor should supply sufficient quantity of touch-up paint of various colours/shades of paints used. The vendor shall ensure performing touching after commissioning but before final acceptance.	Vendor to offer	
10	<b>AMBIENT CONDITIONS &amp; THERMAL STABILITY</b>		
10.1	Total machine including all supplied items should work trouble free and should give specified accuracies under existing power supply and ambient operating conditions, as mentioned below:	Vendor to accept & confirm	
10.2	Ambient Operating Conditions: Temperature = 5 to 45-degree Celsius Relative Humidity = 95% max. Weather conditions are tropical. Atmosphere may be dust laden during some part of the year. Machine shall be kept in the normal shop floor condition without any temperature controlled enclosure/shop. Max. temperature variation is 25 deg Celsius in 24 hours.	Vendor to accept	
10.3	Thermal Stability: Thermal Stability of the complete machine and all supplied items keeping in view the specified Ambient Conditions, accuracies, requirements of BHEL components and trouble free operation of the machine should be ensured by vendor. Since the machine shall be installed in shop with operating conditions, the vendor shall ensure minimum bonding required for achieving the acceptable result in UDT.	Vendor to offer & confirm	
11	<b>MACHINE ACCEPTANCE (TESTS/ACTIVITIES TO BE PERFORMED &amp; DEMONSTRATED BY THE VENDOR)</b>	Vendor to note	
11.1	<b>TESTS/ACTIVITIES TO BE CARRIED OUT AT VENDOR'S WORKS ON THE MACHINE BEFORE DISPATCH :</b>	Vendor to note	
11.2	Demonstration of specified/offered capacity of machine	Vendor to accept & confirm	
11.3	The machine should be tested for continuous running of minimum 24 hrs. If any break down occurs during this test, the test should be repeated for 24 hrs from that time.	Vendor to accept & confirm	
11.4	Demonstration of all features of the machine, control system & accessories and trouble shooting	Vendor to accept & confirm	

## 1726146/2023/HERP-MAINT

11.5	Dry testing of bearing with shell of having minimum weight 1000 Kg ( Bearing/shell to be provided by vendor)	Vendor to note	
12	<b>TESTS/ACTIVITIES TO BE CARRIED OUT AT BHEL WORKS WHILE COMMISSIONING THE MACHINE AT HERP.</b>		
12.1	Demonstration of features, capability of RPM control and variation with load, cooling system etc shall be demonstrated after starting up of machine at HERP.	Vendor to accept & confirm	
12.2	Full load test to demonstrate the maximum power & clamping capacity of the machine.	Vendor to accept & confirm	
12.3	The machine should be tested for continuous running of 48 hrs. If any break down occurs during this test, the test should be repeated for 48 hrs from that time.	Vendor to accept & confirm	
12.4	Demonstration of all features of the machine, control system & accessories, and troubleshooting to the satisfaction of BHEL for efficient and effective use of the machine	Vendor to accept & confirm	
12.5	Demonstration by actual use of all supplied accessories to their full capacity for required applications.	Vendor to accept & confirm	
12.6	BHEL Persons should be trained for the area & period given below for 1 week: (a) Process, programming & operation for the machine, measuring system, etc. (b) Process, Bearing preparation. (c) Babbitting process and key control variables. (d) Maintenance of machine & other supplied equipment/accessories	Vendor to accept & confirm	
12.7	Job prove out and testing: NDT of the Rebabbed bearing shall be carried out as per NDT SPECIFICATION- HW0850195 (attached as Annexure E) & job prove out as per Clause 6 of this document.	Vendor to accept & confirm	
13	<b>PACKING</b> Sea worthy & rigid packing for machine, control and all other supplied items to avoid any damage/loss in transit. All small loose items should be suitably packed in boxes	Vendor to offer & confirm	
14	<b>GUARANTEE :</b> Guarantee for complete machine and all supplied systems/accessories / attachments /equipment/items for 24 months from the date of acceptance of the machine.( Note: Warranty shall not be applicable on wearing parts such as bearings, spray nozzles and pouring spout, melting pot, thermo couple, Pouring spout, Water nozzles, Hydraulic oil, Hydraulic filter)	Vendor to confirm	
15	<b>DOCUMENTATION:</b> Three sets of following documents in hard & soft copy ( atleast 02 hard copies of OEM manual) as per details mentioned under ( English language only):-	Vendor to confirm	
15.1	Operating manuals of Machine & CNC system	Vendor to offer	
15.2	Programming Manuals of Machine & CNC system	Vendor to offer	
15.3	Detailed maintenance manual of machines with all drawings of machines assemblies/subassemblies including electrical/pneumatic/Coolant/Hydraulic circuit diagram. All assembly/Subassembly drawing shall be supplied with the part list also covering complete master list of parts used in the machine	Vendor to offer	
15.4	Maintenance Interface & commissioning manuals for CNC system spindle & feed drives.	Vendor to offer	
15.5	Manufacturing drawings for all supplied tool holders, coolant connections, adapters , sleeves, fixtures etc.	Vendor to offer	
15.6	Catalogues, Operation & Maintenance Manuals of all bought out items including drawings, wherever applicable.	Vendor to offer	
15.7	Detailed specification of all rubber items and hydraulic/Tube fittings & hoses.	Vendor to offer	
15.8	Program print-outs (hard copy) for PLC of main machine and auxiliary systems (if used)along with Comments, cross reference list and Input/output list in English.	Vendor to offer	
15.9	PLC programs print out with comments in English.	Vendor to offer	
15.1	Complete Master list of parts used in the machine shall be submitted by the vendor.	Vendor to offer	
15.11	Electrical Schematic Diagrams, Wiring Diagrams, Junction Box Layouts, Connector Diagrams and Cable Layouts of the machine in English.	Vendor to offer	
15.12	Vendor to submit list of all Mandatory spare parts required for the trouble free working of the machine at the time of supply of machine.		
15.13	Drawings of machine assemblies/sub-assemblies/parts including Pneumatic/ Coolant / Hydraulic circuit diagrams. All Assembly/ Sub Assembly Drawings shall be supplied with the part list marked on it in English.	Vendor to offer	

## 1726146/2023/HERP-MAINT

	<b>DELIVERY, INSTALLATION &amp; COMMISSIONING SCHEDULE</b>		
16	Delivery Schedule- For PDI outside India- 9 months from the placement of purchase order to submission of B/L for dispatch of machine For PDI in India : 9 months from the placement of purchase order to receipt of machine at HERP Stores	vendor to confirm	
	The validity of the offer shall be minimum 120 days.	vendor to confirm	
	Installation & commissioning should be completed within 60 days from the receipt of confirmation of site readiness from BHEL. The site readiness intimation shall be given within 30 days from the receipt of machine (subject to travel restrictions)	vendor to confirm	
17	Technical support for 6 months or 100 pouring which ever is earlier shall be provided by the OEM through remote assistance to BHEL in which process & parameter for each pouring shall be reviewed by the OEM for which all required details shall be shared 24 hours in advance. The objective of the action shall be to gradually minimize the failure rate and process improvement. OEM should confirm and quote the charges for assistance in price bid. The payment shall be made after completion of 6 months or 100 pouring and within 60 days of receipt of invoice against same/separate work order. (The charges shall be considered for evaluating L-1 bidder).	Vendor to accept & confirm	
18	In case of on site requirement at HERP, OEM may be required to depute 01 person for 5 day stay at HERP to carry out pouring. OEM should submit per man day cost for providing on site assistance at BHEL Varanasi. The period of stay shall be minimum 5 days at a stretch while travel charges (except local conveyance expenditure incurred abroad), accommodation in India, local conveyance expenditure shall be borne by BHEL. The rates shall be valid for minimum 24 months from the date of commissioning. (Bidder to quote in price bid in separately provided field). The payment shall be made within 60 days of receipt of invoice against same/separate work order and completion of each visit. (The charges shall not be considered for evaluating L-1 bidder. The successful bidder shall have to accept the lowest rate offered amongst all techno-commercially qualified bidders.)	Vendor to quote here	
	<b>GENERAL :</b>		
19	Machine Model	Vendor to specify	
	Total connected load (KVA):	Vendor to specify	
	Floor area required (Length, Width, Height) for complete machine & accessories.	Vendor to specify	
	Painting of Machine / Electrical Panels :(Apple green or as per OEM offered standard color to be informed by OEM for BHEL acceptance	Vendor to confirm	
	Total weight of the machine	Vendor to specify	
	<b>LIST OF APPROVED MAKE FOR ITEMS</b>		
	VVVF Make & rating for the main motor	Make Siemens/ ABB/ALLEN BRADLEY or equivalent	
	Bearings for both end spindle/spinner/faceplate/ Head stock	Make INA/FAFNIR/RHP /FAG/SKF/ TIMKEN ONLY	
	Hydraulic pump & cylinder	Duplomatic/Bosch/Rexroth /HAWE or equivalent	
	MCB/ ELCB/MPCB/MCCB :	Schnieder / ABB/ L&T/ SIEMENS or any other reputed make	
	PLC & HMI	Make Siemens only	
	Panel AC	Rittal or equivalent Make	
	Motor for Head stock, Power pack etc	Siemens/ ABB/CG/ALSTOM or equivalent	
	Pumps, Valves, Switches	Rexroth / Vickers/Parker/Hawe or equivalent	

SL. NO.	DESCRIPTION OF BHEL REQUIREMENT	REQUIRED	OFFERED
1	<p>Bidder can be Domestic or foreign Original Equipment Manufacturer (OEM) meeting following qualifying requirement:</p> <p>1(a) Bidder should have successfully supplied &amp; commissioned at least one Centrifugal Casting Machine suitable for babbitting of bearing of weight 1500 KGS or higher (mounting fixtures weight additional not considered) within last 14 years considered from the date of floating of the NIT.</p> <p>1(b) Above machine should have been commissioned and presently working satisfactorily for a minimum 12 Months period considered from the date of floating of NIT.</p> <p>1(c) Bidder should have sufficient experience of manufacturing/ Engineering/ designing of similar capacity Centrifugal Casting Machine for at least 7 years period from the date of floating of NIT.</p>	Bidder to confirm & submit PO copy with performance certificate as per prescribed format (attached) from their customers on their letter head.	
2	<b>FINANCIAL REQUIREMENT</b>		
3	<b>CAPABILITY</b>		
3.1	<p>Bidder should have critical in house machining facility &amp; necessary qualified technical manpower for manufacturing the machine. Manufacturing and the pre-dispatch inspection of the machine shall be carried at this location.</p> <p><b>APPLICABLE TO FOREIGN OEM UNDER RELAXATION FROM CLAUSE (3.1):</b></p> <p>Foreign OEM meeting the qualifying requirement at Clause (1) but not meeting qualifying requirement at Clause (3.1) can submit bid through Indian bidder meeting the requirement at Clause (3.1) in India as well as following requirement:</p> <p>Indian bidder should submit the bid along with documents for Collaboration/ Joint Venture/ Joint Working Arrangement/License/ binding MoU, between both entities mentioning the scope of work and obligation of each partner for manufacturing, supply, commissioning, warranty support &amp; technical support for Centrifugal casting machine suitable for lining white metal (BABBITT) in Journal bearings of OD up to 1030 mm &amp; weight 2500 KGS (including mounting fixtures), with foreign OEM meeting above mentioned qualifying criteria at Clause (1).</p> <p>In this case the Indian bidder should meet the financial requirement at Clause 2 &amp; PO shall be placed on Indian bidder in INR currency.</p>	Bidder to submit details.	Bidder to confirm and bids to be supported with documents.
3.2			

Pradeep Kumar  
PRADEEP KUMAR

A. N. Singh

Adish  
S.K. Singh  
S. M. Singh

10/10/23

	<p><b>Pls Note:</b> BHEL may ask bidder to furnish additional(modified) undertaking/documents/ guarantees which may seem necessary to ensure performance &amp; service of the equipment. BHEL shall assess both the entities and may review the adequacy of documents /format of document asked to submit (submitted) and shall reserve the right to accept/reject the bid which shall be final.</p> <p><b>ADDITIONAL REQUIREMENT FOR FOREIGN OEM FROM COUNTRIES SHARING LAND BOUNDARY WITH INDIA AND NOT REGISTERED WITH DPIIT:</b></p> <p>Foreign OEM from countries sharing land boundary with india &amp; meeting the qualifying requirement at clause (1) &amp; (3.1) may submit bid through Indian bidder having facility in india where local content value addition shall be carried out as per applicable guidelines of Government of India for imposition of restrictions on bidders from countries which share a land border with India.</p> <p>Indian bidder should submit the bid along with documents for Collaboration/ Joint Venture/ Joint Working Arrangement/License/ binding MoU, between both entities mentioning the scope of work and obligation of each partner for manufacturing, supply, commissioning, warranty support &amp; technical support for Centrifugal casting machine suitable for lining white metal (BABBIT) in Journal bearings of OD up to 1030 mm &amp; weight 2500 KGS (including mounting fixtures), with foreign OEM meeting above mentioned qualifying criteria at Clause (1).</p> <p>In such case, both the Indian bidder &amp; foreign partner both should individually meet the financial requirement at Clause (2) &amp; PO shall be placed on Indian bidder in INR currency.</p> <p><b>Pls Note:</b> BHEL may ask bidder to furnish additional(modified) undertaking/documents/ guarantees which may seem necessary to ensure performance &amp; service of the equipment. BHEL shall assess both the entities and may review the adequacy of documents /format of document asked to submit (submitted) and shall reserve the right to accept/reject the bid which shall be final.</p>		
3.3		Bidder to confirm and bids to be supported with documents.	
4	<p><b>WARRANTY &amp; SERVICE SUPPORT</b></p> <p>Bidder shall assure a continuous support for spares and service for ten (10) years, from the date of commissioning of the equipment at BHEL works. Bidder should agree for Guarantee on complete machine and all supplied systems/accessories / attachments /equipment/Bought out items for 24 months from the date of acceptance of the machine.</p> <p>(Note: Guarantee shall not be applicable on wearing parts such as bearings, spray nozzles and pouring spout, melting pot, thermocouple, Pouring spout, Water nozzles, Hydraulic oil, Hydraulic filter)</p>	Bidder to confirm	
4.1			
4.2	<p><b>APPLICABLE TO BID SUBMITTED UNDER CLAUSE (3.2) or (3.3):</b></p> <p>Indian Bidder and Foreign OEM should confirm to submit following documents at the time of placement of PO:</p> <p>a. Joint Deed of Undertaking for Guarantee &amp; service support mentioning terms &amp; conditions mentioned at Clause No-(4.1).</p> <p>b. Back to back bank guarantee from Foreign OEM for satisfactory performance of the offered machine in compliance to all specified tender requirements (Refer General Terms &amp; conditions of NIT).</p>	Bidder to confirm	

R. Pradeep Kumar  
10/10/23  
S. Pradeep Kumar

Pradeep Kumar  
(PRADEEP KUMAR)

(A.N. Singh)  
(A.N. Singh)

(S.V. Sathy)  
(S.V. Sathy)



COMBINED BILL OF MATERIAL

CBOM No: 01183658000 CBOM Var: 00  
 Description: JOURNAL BEARING D530X530

Revno: 3

Rev Date: 27.01.2022

Total weight: 1945.0

Printed On: 27.09.2023

Printed By:

113/234  
 172  
 Annature - C

**RECORD OF CHANGES**

Drawing No	Var	Revno	Rev Date	Description
01183658000	00	1	04.10.2017	FOR ITEM NO.4 ST05023.093 CHANGED TO ST05006.157.
01183658000	00	2	02.12.2020	Auto Revision 41181456118/00
01183658000	00	3	27.01.2022	Auto Revision ST24002/032

Pg - 01 of 19

(Superventral)

Prove-out

CBOM - 01183658000 00

	ENGG		MTE		TTX	
	Initial	Date	Initial	Date	Initial	Date
Worked By	sterk	09.04.2012	mtepa	30.04.2012	ttxdk	12.04.2012
Checked By	stepdk	12.04.2012	mtepa	30.04.2012	ttxdk	05.05.2012
Approved By	steas	10.05.2012	mtejpm	04.05.2012	ttxss	07.05.2012



COMBINED BILL OF MATERIAL

CROM No: 01183658000 CROM Var: 00

Description: JOURNAL BEARING D530X530

Revno: 3

Rev Date: 27.01.2022

Total weight: 1945.0

Printed On: 27.09.2023

Printed By:

02

Item No	Drawingno	Var Mvar	Mat Code	Mat Spec	Weight	Inclusion?	Blank Sizes	Mat Shape	Remarks	Qty	Nos	Extra Norm	Total Norm
0	01183658000	00			1945.0								
(1)	JOURNAL BEARING D530X530				Y								
1	01183658100	00 00			1851.0								
(1)	JOURNAL BEARING SHELL				N								
MF DR					0236								

1-1	FORGING FOR BEARING SHELL		HW19361		1792.0					1	0	1.0	0.0
(1)	FORGING FOR BEARING SHELL		C22+N		N								
FE DR	FORGING FOR BEARING SHELL				0073-0236								
1-2	BABBIT MATERIAL		HW12897		59.0					0	0	260.0	0.0
(1)					N								
RM DR	SPL-TIN-BASED-ALY-ANT-FRICTION				0072-0227								
2	ST01011 408		AA10622		2.94					0	0	0.0	0.0
(4)	STUD		DIN2510,21CRM0V57,EN10060		N								
MF DR	M56X245				0072-0236								
3	31181456104 00 00		W97311814049		2.0					0	0	0.0	0.0
(4)	TORQUE NUT		M/S SUPERBOLT		N								
BO DR	MT-M56X5.5/W				0074-0236								
4	ST05006 157		HW10683		0.57					1	0	1.577	0.0
(4)	TAPER PIN				N								
MF DR	25X140				0072-0236								
5	21181456106 00 00		AA105227180		70.0					0	0	270.0	0.0
(1)	TOROUS PIECE		S355J2G3+N, DIN7527		N								
FI DR					0072-0356-0359-0236								
6	41181456107 00 00		AA1011819139		0.8					1	0	1.26	0.0
(2)	PLATE		S235JR, EN10058		N								
MF DR	S=20				0072-0301-0236								
7	41181456108 00 00		AA1071740113		0.09					1	0	0.09	0.0
(2)	SHIM		X6CrNiTi18-10, ISO9445		N								
MF DR	S=2				0072-0321-0236								

Initial	Date	Initial	Date	Initial	Date	Initial	Date
Worked By	09.04.2012	stkrk	30.04.2012	mtpea	30.04.2012	mtpea	30.04.2012
Checked By	12.04.2012	stepdk	10.05.2012	tejpm	04.05.2012	txss	05.05.2012
Approved By		steas					07.05.2012



COMBINED BILL OF MATERIAL

*Supercritical HW-*

03

CBOM No: 01183658000 CBOM Var: 00  
 Description: JOURNAL BEARING D530X530

Revno: 3

Rev Date: 27.01.2022

Printed On: 27.09.2023

Printed By:

Total weight: 1945.0

Item No	Drawingno Var Mvar	Mat Code	Mat Spec	Weight	Blank Sizes	Nos	Qty	Norm/pc	Extra Norm	Total Norm
Qty( Total)	Description		Assy. Remarks	Inclusion?	Mat Shape			Remarks		
Typ Cat Zone	Var/Matl. Description		ENGG SIZE/GRP	Fab Wt	Route				Spare Code	Unit
8	41181456108 01 00	AA1071740032	AA10740	0.02	170.0X600.0	14	0	0.029	0.0	0.0
4(4)	SHIM		X6CrNiTi18-10, ISO9445	N	SH 0.5			for blanking only		
MF DR	S=0.5				0072-0370-0236					KG
9	41181456108 02 00	HW1071740962	AA10740	0.009	170.0X600.0	14	0	0.011	0.0	0.0
4(4)	SHIM		X6CrNiTi18-10, ISO9445	N	SH 0.2			for blanking only		
MF DR	S=0.2				0072-0370-0236					KG
10	41181456108 03 00	HW1071740946	AA10740	0.004	170.0X600.0	14	0	0.006	0.0	0.0
4(4)	SHIM		X6CrNiTi18-10, ISO9445	N	SH 0.1			for blanking only		
MF DR	S=0.1				0072-0370-0236					KG
11		HW7123196961	HW7123196	0.04	0.0	0	0	0.0	0.0	0.0
4(4)	SCRU CAP P-8.8		ISO4762, ~8.8	N						
SI DR	M10X20				0075-0236					NO
12		HW7123196740	HW7123196	0.36	0.0	1	0	1.0	0.0	0.0
4(4)			ISO4762, 21CrMoV5-7	N	M20X130					
SI DR	SCRU CAP P-8.8				0075-0236					NO
13	41181456114 00 00	AA1071740113	AA10740	1.2	170.0X440.0	1	0	1.23	0.0	0.0
2(2)	SHIM		X6CrNiTi18-10, ISO9445	N	SH 2.0					
MF DR	S=2				0072-0321-0236					KG
14	41181456114 01 00	AA1071740032	AA10740	0.2	450.0X600.0	3	0	0.353	0.0	0.0
3(3)	SHIM		X6CrNiTi18-10, ISO9445	N	SH 0.5			for blanking only		
MF DR	S=0.5				0072-0370-0236					KG
15	41181456114 02 00	HW1071740962	AA10740	0.1	450.0X600.0	3	0	0.141	0.0	0.0
2(2)	SHIM		X6CrNiTi18-10, ISO9445	N	SH 0.2			for blanking only		
MF DR	S=0.2				0072-0370-0236					KG
16	41181456114 03 00	HW1071740946	AA10740	0.05	450.0X600.0	3	0	0.07	0.0	0.0
2(2)	SHIM		X6CrNiTi18-10, ISO9445	N	SH 0.1			for blanking only		
MF DR	S=0.1				0072-0370-0236					KG
17	41181456118 00 00	HW1060273160	HW10673	0.07	40.0	1	0	0.281	0.0	0.0
2(2)	SCREW PLUG G1/2 A		DIN910, 25CrMo4+QT	N	RND 30					
MF DR					0074-0236					KG

	ENGG		MTE		TTX	
	Initial	Date	Initial	Date	Initial	Date
Worked By	sterk	09.04.2012	mtepa	30.04.2012	ttxdk	12.04.2012
Checked By	stepdk	12.04.2012	mtepa	30.04.2012	ttxdk	05.05.2012
Approved By	steas	10.05.2012	mtejpm	04.05.2012	ttxss	07.05.2012





NO.	REV.	DATE	DESCRIPTION
1	0	01/18/2023	ISSUED FOR PURCHASE
2	1	02/01/2023	REVISED PER COMMENTS
3	2	02/15/2023	REVISED PER COMMENTS
4	3	02/28/2023	REVISED PER COMMENTS
5	4	03/15/2023	REVISED PER COMMENTS
6	5	03/28/2023	REVISED PER COMMENTS
7	6	04/10/2023	REVISED PER COMMENTS
8	7	04/25/2023	REVISED PER COMMENTS
9	8	05/10/2023	REVISED PER COMMENTS
10	9	05/25/2023	REVISED PER COMMENTS
11	10	06/10/2023	REVISED PER COMMENTS
12	11	06/25/2023	REVISED PER COMMENTS
13	12	07/10/2023	REVISED PER COMMENTS
14	13	07/25/2023	REVISED PER COMMENTS
15	14	08/10/2023	REVISED PER COMMENTS
16	15	08/25/2023	REVISED PER COMMENTS
17	16	09/10/2023	REVISED PER COMMENTS
18	17	09/25/2023	REVISED PER COMMENTS
19	18	10/10/2023	REVISED PER COMMENTS
20	19	10/25/2023	REVISED PER COMMENTS
21	20	11/10/2023	REVISED PER COMMENTS
22	21	11/25/2023	REVISED PER COMMENTS
23	22	12/10/2023	REVISED PER COMMENTS
24	23	12/25/2023	REVISED PER COMMENTS
25	24	01/10/2024	REVISED PER COMMENTS
26	25	01/25/2024	REVISED PER COMMENTS
27	26	02/10/2024	REVISED PER COMMENTS
28	27	02/25/2024	REVISED PER COMMENTS
29	28	03/10/2024	REVISED PER COMMENTS
30	29	03/25/2024	REVISED PER COMMENTS
31	30	04/10/2024	REVISED PER COMMENTS
32	31	04/25/2024	REVISED PER COMMENTS
33	32	05/10/2024	REVISED PER COMMENTS
34	33	05/25/2024	REVISED PER COMMENTS
35	34	06/10/2024	REVISED PER COMMENTS
36	35	06/25/2024	REVISED PER COMMENTS
37	36	07/10/2024	REVISED PER COMMENTS
38	37	07/25/2024	REVISED PER COMMENTS
39	38	08/10/2024	REVISED PER COMMENTS
40	39	08/25/2024	REVISED PER COMMENTS
41	40	09/10/2024	REVISED PER COMMENTS
42	41	09/25/2024	REVISED PER COMMENTS
43	42	10/10/2024	REVISED PER COMMENTS
44	43	10/25/2024	REVISED PER COMMENTS
45	44	11/10/2024	REVISED PER COMMENTS
46	45	11/25/2024	REVISED PER COMMENTS
47	46	12/10/2024	REVISED PER COMMENTS
48	47	12/25/2024	REVISED PER COMMENTS
49	48	01/10/2025	REVISED PER COMMENTS
50	49	01/25/2025	REVISED PER COMMENTS

STEAM TURBINE

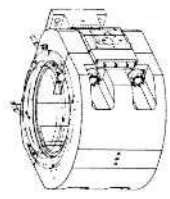
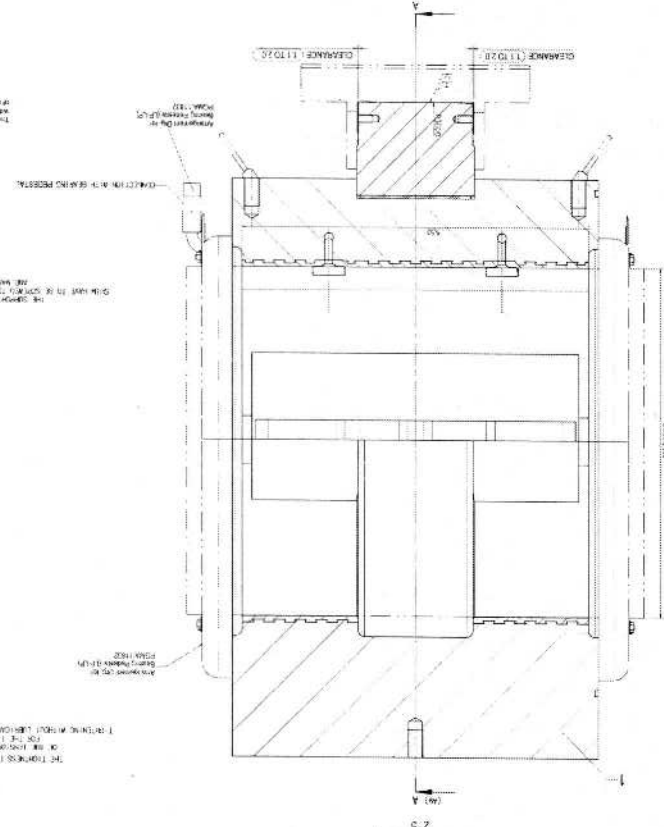
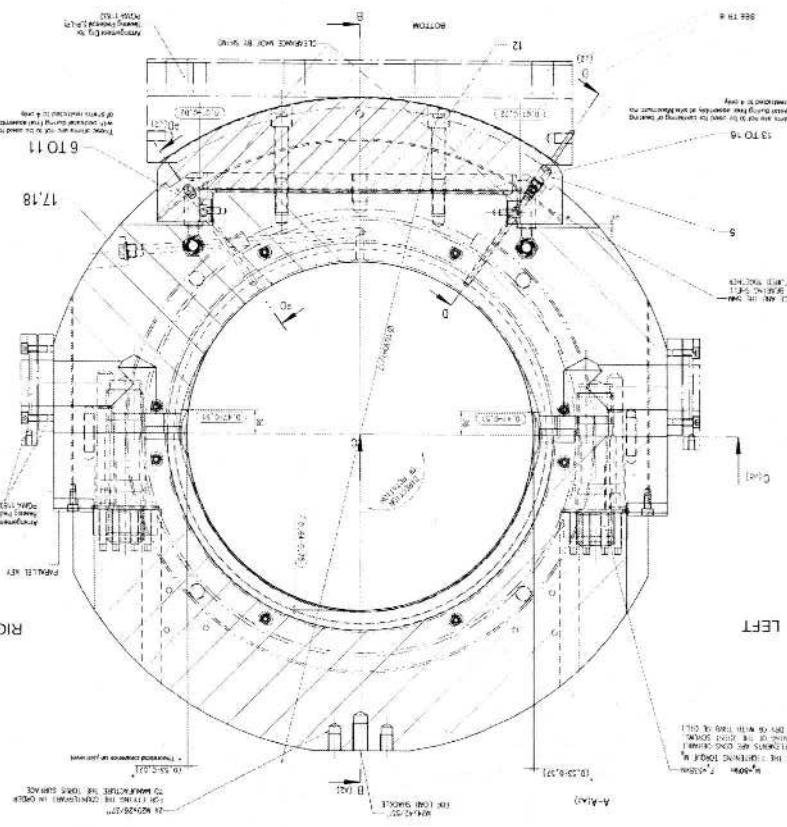
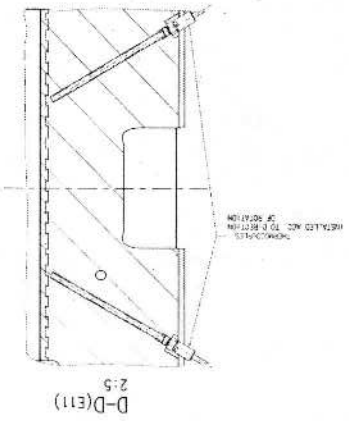
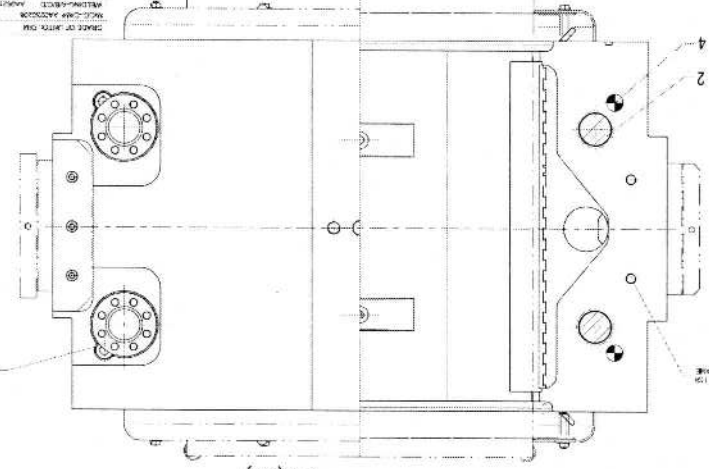

**Technical Requirements**

1. MATERIALS: ALL MATERIALS SHALL BE AS SPECIFIED IN THE DRAWINGS AND SHALL BE OF THE HIGHEST QUALITY AVAILABLE.
2. FABRICATION: THE FABRICATION SHALL BE IN ACCORDANCE WITH THE REQUIREMENTS OF THE DRAWINGS AND SHALL BE OF THE HIGHEST QUALITY AVAILABLE.
3. FINISH: ALL SURFACES SHALL BE FINISHED TO THE REQUIREMENTS OF THE DRAWINGS AND SHALL BE OF THE HIGHEST QUALITY AVAILABLE.
4. TOLERANCES: ALL DIMENSIONS SHALL BE TO THE TOLERANCES SPECIFIED IN THE DRAWINGS AND SHALL BE OF THE HIGHEST QUALITY AVAILABLE.
5. INSPECTION: THE FABRICATION SHALL BE INSPECTED AT ALL STAGES OF THE FABRICATION AND SHALL BE OF THE HIGHEST QUALITY AVAILABLE.
6. TESTING: THE FABRICATION SHALL BE TESTED AT ALL STAGES OF THE FABRICATION AND SHALL BE OF THE HIGHEST QUALITY AVAILABLE.
7. DOCUMENTATION: THE FABRICATION SHALL BE DOCUMENTED AT ALL STAGES OF THE FABRICATION AND SHALL BE OF THE HIGHEST QUALITY AVAILABLE.
8. DELIVERY: THE FABRICATION SHALL BE DELIVERED TO THE SITE IN ACCORDANCE WITH THE REQUIREMENTS OF THE DRAWINGS AND SHALL BE OF THE HIGHEST QUALITY AVAILABLE.
9. WARRANTY: THE FABRICATION SHALL BE WARRANTED TO BE OF THE HIGHEST QUALITY AVAILABLE FOR A PERIOD OF 12 MONTHS FROM THE DATE OF DELIVERY.
10. OTHER: ALL OTHER REQUIREMENTS SHALL BE AS SPECIFIED IN THE DRAWINGS AND SHALL BE OF THE HIGHEST QUALITY AVAILABLE.



COMBINED BILL OF MATERIAL

CBOM No: 01181402000    CBOM Var: 00    Revno: 15    Rev Date: 19.11.2019  
 Description: JOURNAL BEARING D500X450    Total weight: 2320.0

Printed On: 27.09.2023  
 Printed By:

7

RECORD OF CHANGES				
Drawing No	Var	Revno	Rev Date	Description
01181402000	00	1	04.05.2001	Automatic chg 21181801027/02 21181801027/03, 21181801027/04
01181402000	00	2	28.02.2002	it 30 blank size changed from 193 to 90
01181402000	00	4	05.08.2003	Automatic chg ST24002 /03
01181402000	00	5	17.07.2007	Automatic chg 01181402010/00
01181402000	00	6	13.09.2007	Automatic chg 11181402020/00
01181402000	00	7	20.09.2007	Automatic chg 21181801053/00
01181402000	00	8	04.12.2008	AUTOMATIC-BULK MATCODE CHG
01181402000	00	9	22.06.2009	Automatic chg 11181402020/00
01181402000	00	10	23.07.2009	Automatic chg 01181402010/00
01181402000	00	11	11.07.2012	Auto Revision 21181801027/00 21181801027/02; 21181801027/03
01181402000	00	12	14.11.2014	ITEM NO. 60 & 61 ADDED
01181402000	00	13	05.01.2015	Auto Revision ST05010/095
01181402000	00	14	05.01.2015	Auto Revision ST05010/095
01181402000	00	15	19.11.2019	Auto Revision ST22004/003

HW-165-27

CBOM - 01181402000 00

	ENGG		JTE		MTE		TTX		WTX	
	Initial	Date	Initial	Date	Initial	Date	Initial	Date	Initial	Date
Worked By	stedkr	21.11.1998	jtemlv	20.01.1999	mtenpb	04.01.1999	ttxas	28.01.1999	wtxcbs	24.12.1998
Checked By	stedkr	23.12.1998	jtemlv	20.01.1999	mteaks	04.01.1999	ttxas	28.01.1999	wtxbch	24.12.1998
Approved By	steakj	02.02.1999	jteskg	22.01.1999	mteaks	04.01.1999	ttxdch	28.01.1999	wtxhpr	24.12.1998



# COMBINED BILL OF MATERIAL

GROM No: 01181402000 GROM Var: 00

Description: JOURNAL BEARING D500X450

Revno: 15

Rev Date: 19.11.2019

Total weight: 2320.0

Printed On: 27.09.2023

Printed By:

Item No	Drawing No	Var	Mat Code	Mat Spec	Weight	Blank Sizes	Inclusion?	Fab Wt	Route	Remarks	Extra Norm	Total Norm
0	01181402000	00			2320.0							
1(1)	JOURNAL BEARING D500X450											
MF DR												
1	01181402010	00			1343.0							
1(1)	JOURNAL BEARING SHELL											
MF DR J16												
1-1	01181402011	00	W94311814011	HW19361	1358.0							
1(1)	BEARING SHELL(IN TWO HALVES)											
FE DR L16												
1-5	HW1285097009		HW12897		51.0							
1(1)	BABBIT LINING											
RM DR M5												
2	21181801021	00	AA1015227198	AA19332	112.0							
1(1)	CYLINDRICAL SUPPORT											
FI DR D6												
3	21181801022	00	HW1055276017	AA19341	65.0							
1(1)	TORUS-PIECE											
FI DR D6												
4	41181801023	00	AA1011819155	AA10119	0.8							
2(2)	SPACER											
MF DR E6												
4	41181801024	00	W92311818015	HW19598	650.0							
1(1)	BEARING CAP											
CE DR L10												
6	HW7123125878		AA7123125		0.023							
4(4)	SCRU CAP SOC TH HD A-8.8											
BO DR E6												
7	21181801025	00	HW1011819953	AA10119	3.9							
2(2)	SPACER											
MF DR F12												

Item No	Description	Mat Code	Mat Spec	Assy. Remarks	ENG SIZE/GRP	Blank Sizes	Weight	Inclusion?	Fab Wt	Route	Remarks	Extra Norm	Total Norm
1	01181402010	00					1343.0						
1(1)	JOURNAL BEARING SHELL												
MF DR J16													
1-1	01181402011	00	W94311814011	HW19361			1358.0						
1(1)	BEARING SHELL(IN TWO HALVES)												
FE DR L16													
1-5	HW1285097009		HW12897				51.0						
1(1)	BABBIT LINING												
RM DR M5													
2	21181801021	00	AA1015227198	AA19332			112.0						
1(1)	CYLINDRICAL SUPPORT												
FI DR D6													
3	21181801022	00	HW1055276017	AA19341			65.0						
1(1)	TORUS-PIECE												
FI DR D6													
4	41181801023	00	AA1011819155	AA10119			0.8						
2(2)	SPACER												
MF DR E6													
4	41181801024	00	W92311818015	HW19598			650.0						
1(1)	BEARING CAP												
CE DR L10													
6	HW7123125878		AA7123125				0.023						
4(4)	SCRU CAP SOC TH HD A-8.8												
BO DR E6													
7	21181801025	00	HW1011819953	AA10119			3.9						
2(2)	SPACER												
MF DR F12													



COMBINED BILL OF MATERIAL

Printed On:27.09.2023

CBOM No: 01181402000 CBOM Var: 00  
 Description: JOURNAL BEARING D500X450

Revno: 15

Rev Date: 19.11.2019

Printed By:

9

Total weight: 2320.0

Item No	Drawingno Var Mvar	Mat Code	Mat Spec	Weight	Blank Sizes	Nos	Qty	Norm/pc	Extra Norm	Total Norm
Qty( Total)	Description		Assy. Remarks	Inclusion?	Mat Shape			Remarks		
Typ Cat Zone	Var/Matl. Description		ENGG SIZE/GRP	Fab Wt	Route				Spare Code	Unit
8	21181801026 00 00	AA1011819198	AA10119	4.0	140.0X210.0	1	1	11.3	0.0	11.3
1(1)	SPACER			Y	PL 40			PL 40X140X210		
MF DR F12					0072-0301-0236					KG
9		AA7123130057	AA7123123	0.307	0.0	0	0	0.0	0.0	4.0
4(4)	SCRU CAP SOC P-12.9		CUT TO SUIT.	Y						
BO DR C9	M20X100				0075-0236					NO
10	21181801027 00 00	AA1071740075	AA10740	1.7	350.0X620.0	1	1	1.72	0.0	1.72
1(1)	SHIM			Y	SH 1.0			SHEET SH.=1;630		
MF DR C9	S=1.0				0072-0370-0236					KG
11	21181801027 01 00	AA1071740113	AA10740	3.4	360.0X630.0	1	3	4.8	0.0	14.4
3(3)	SHIM			Y	SH 2.0					
MF DR C9	S=2.0				0072-0321-0236					KG
12	21181801027 02 00	AA1071740032	AA10740	0.9	350.0X620.0	1	3	0.86	0.0	2.58
3(3)	SHIM			Y	SH 0.5					
MF DR C9	S=0.50				0072-0370-0236					KG
13	21181801027 03 00	HW1071740962	AA10740	0.3	350.0X620.0	1	3	0.344	0.0	1.032
3(3)	SHIM			Y	SH 0.2					
MF DR C9	S=0.20				0072-0370-0236					KG
14	21181801027 04 00	HW1071740946	AA10740	0.01	350.0X620.0	1	3	0.172	0.0	0.516
3(3)	SHIM			Y	SH 0.1					
MF DR C9	S=0.10				0072-0370-0236					KG
15		HW7123126920	AA7123125	0.037	0.0	0	0	0.0	0.0	8.0
8(8)	SCRU CAP SOC TH.LHD A-8.8			Y						
BO DR M21	M12X25				0075-0236					NO
16	31181401028 00 00	AA1071740075	AA10740	0.04	140.0X1000.0	7	1	0.16	0.0	0.64
4(4)	SHIM			Y	SH 1.0					
MF DR M22	S=1.0				0072-0370-0236					KG
17	31181401028 01 00	AA1071740032	AA10740	0.02	140.0X1000.0	1	4	0.08	0.0	0.32
4(4)	SHIM			Y	SH 0.5					
MF DR M22	S=0.50				0072-0370-0236					KG

	ENGG		JTE		MTE		TTX		WTX	
	Initial	Date	Initial	Date	Initial	Date	Initial	Date	Initial	Date
Worked By	stedkr	21.11.1998	jtemlv	20.01.1999	mtenpb	04.01.1999	ttxas	28.01.1999	wtxcbs	24.12.1998
Checked By	stedkr	23.12.1998	jtemlv	20.01.1999	mteaks	04.01.1999	ttxas	28.01.1999	wtxbch	24.12.1998
Approved By	steakj	02.02.1999	jteskg	22.01.1999	mteaks	04.01.1999	ttxdch	28.01.1999	wtxhpr	24.12.1998



# COMBINED BILL OF MATERIAL

CBOM No: 01181402000 CBOM Var: 00

Description: JOURNAL BEARING D500X450

Revno: 15

Rev Date: 19.11.2019

Total weight: 2320.0

Printed By:

Printed On: 27.09.2023

15

Item No	Drawing No	Var Mvar	Mat Code	Mat Spec	Weight	Inclusion?	Mat Shape	Blank Sizes	Nos	Qty	Norm/pc	Extra Norm	Total Norm
---------	------------	----------	----------	----------	--------	------------	-----------	-------------	-----	-----	---------	------------	------------

Qty (Total)	Description	Var/Matl. Description	ENG SIZE/GRP	Fab Wt	Route	Remarks	Spare Code	Unit
-------------	-------------	-----------------------	--------------	--------	-------	---------	------------	------

18	31181401028 02 00	SHIM	AA10740	0.008	Y	SH 0.2		140.0X1000.0	1	4	0.032	0.0	0.128
19	31181401028 03 00	SHIM	AA10740	0.004	Y	SH 0.1		140.0X1000.0	1	4	0.016	0.0	0.064
20	31181801028 00 00	SHIM	AA10740	0.08	Y	SH 2.0		45.0X170.0	1	2	0.12	0.0	0.24
21	31181801028 01 00	SHIM	AA10740	0.02	Y	SH 0.5		160.0X1000.0	28	1	0.024	0.0	0.096
22	31181801028 02 00	SHIM	AA10740	0.01	Y	SH 0.2		160.0X1000.0	28	1	0.01	0.0	0.04
23	31181801028 03 00	SHIM	AA10740	0.01	Y	SH 0.1		160.0X1000.0	28	1	0.005	0.0	0.02
24	31181801029 00 00	SHIM	AA10740	1.7	Y	SH 4.0	PL,4X170X360	170.0X360.0	1	1	2.15	0.0	2.15
25	31181801029 01 00	SHIM	AA10740	0.2	Y	SH 0.5		350.0X1000.0	6	1	0.234	0.0	0.702
26	31181801029 02 00	SHIM	AA10740	0.1	Y	SH 0.2		350.0X1000.0	6	1	0.1	0.0	0.2
27	31181801029 03 00	SHIM	AA10740	0.05	Y	SH 0.1		350.0X1000.0	6	1	0.05	0.0	0.1

ENGG

JTE

MTE

TTX

WTX

Worked By  
Checked By  
Approved By

steckr  
steckr  
steckj

21.11.1998  
23.12.1998  
02.02.1999

Initial  
Initial  
Initial

20.01.1999  
20.01.1999  
22.01.1999

Initial  
Initial  
Initial

04.01.1999  
04.01.1999  
04.01.1999

Initial  
Initial  
Initial

28.01.1999  
28.01.1999  
28.01.1999

Initial  
Initial  
Initial

24.12.1998  
24.12.1998  
24.12.1998

HERP-PURCHASE

0-118-14-02010

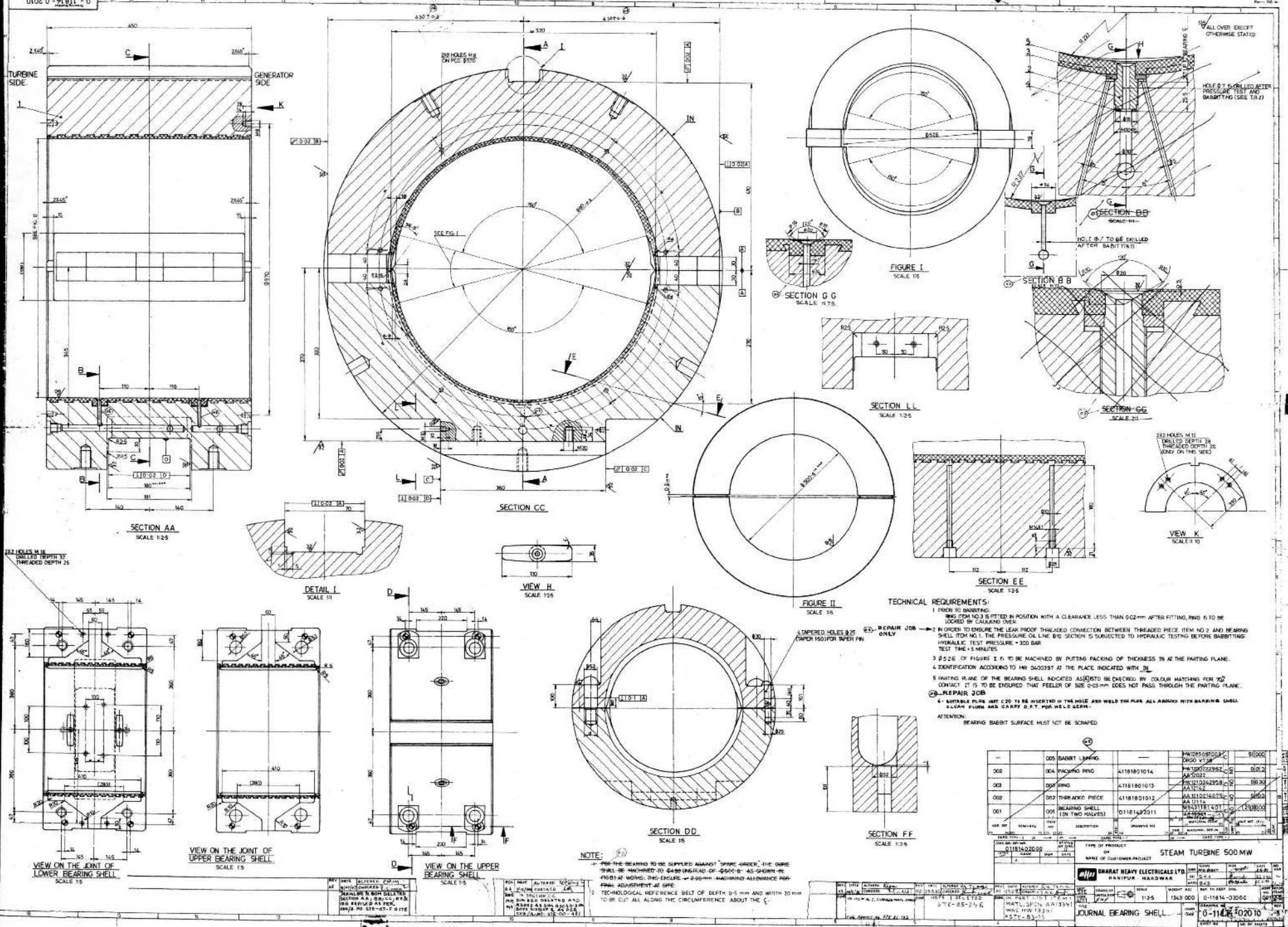

QTY	DES	BARBET LAMPING	HW025-090004	50000
002	004	PACKING RING	A1181801014	01010
002	004	RING	A1181801013	01010
002	002	THREADED PIECE	A1181801012	01010
001	000	BEARING SHELL (IN TWO HALVES)	D1181801011	01010

QTY	DES	NAME OF CUSTOMER PRODUCT	STEAM TURBINE 500 MW
0118150200	0118150200	STEAM TURBINE 500 MW	

QTY	DES	NAME OF CUSTOMER PRODUCT	STEAM TURBINE 500 MW
0118150200	0118150200	STEAM TURBINE 500 MW	



COMBINED BILL OF MATERIAL

CBOM No: 11170327110 CBOM Var: 00  
 Description: BEARING LINER

Revno: 3

Rev Date: 14.07.2009

Total weight: 57.0

Printed On:27.09.2023

Printed By:

12

RECORD OF CHANGES				
Drawing No	Var	Revno	Rev Date	Description

11170327110	00	1	03.03.2001	1. IN ITEM NO.1 OF ASSEMBLY 1-11703-27110,MATERIAL CODE IS CHANGED FROM AA1015227180 TO HW1015280030 AND THE MATERIAL SPECIFICATION CHANGED FROM AA19332 TO HW19361.
11170327110	00	2	02.01.2009	FOR ITEM NO.1 MAT. CODE HW1015280030 CHANGE TO MAT. CODE W94311703066.
11170327110	00	3	03.07.2009	BABBITT WT CORRECTED FOR ITEM NO. 2.

HW-165.25  
Liner

CBOM - 11170327110 00

	ENGG		MTE		TTX	
	Initial	Date	Initial	Date	Initial	Date
Worked By	stedkr	21.12.1998	mtenpb	05.02.1999	ttxas	06.02.1999
Checked By	stedkr	04.02.1999	mteaks	05.02.1999	ttxas	06.02.1999
Approved By	steakj	09.03.1999	mteaks	05.02.1999	ttxdch	06.02.1999



125/ ALLOWER EXCEPT OTHERWISE STATED

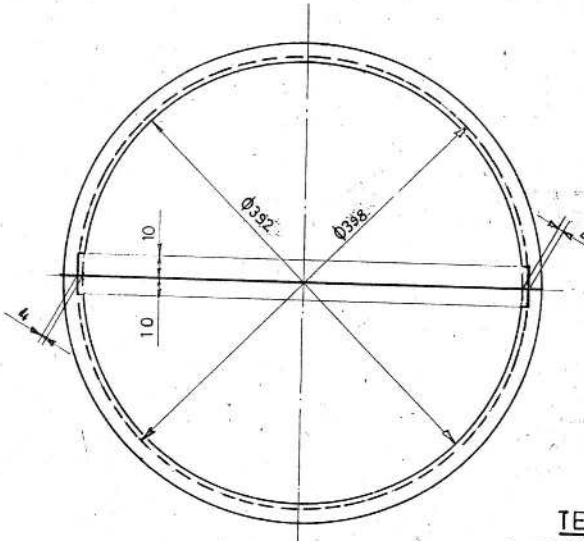
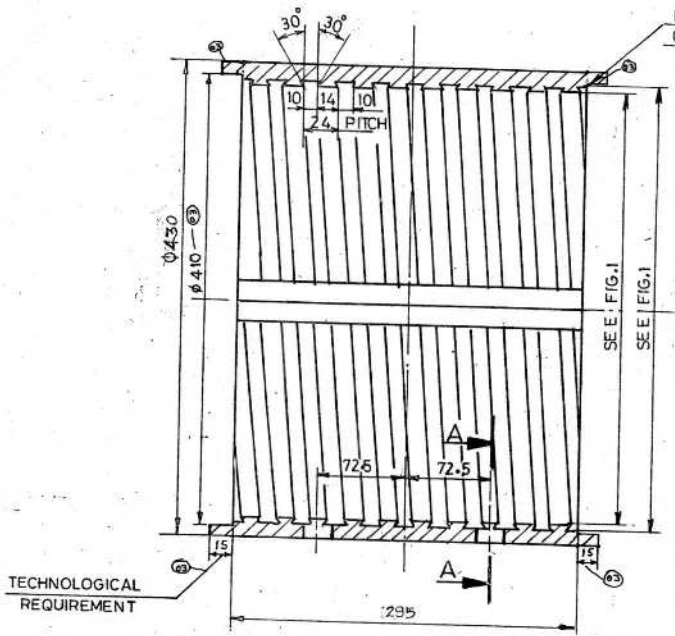
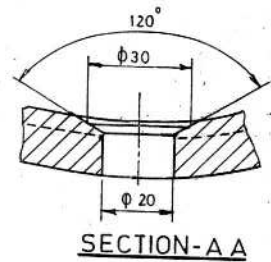

FIG. 1

TECH. REQ. 1. DEHYDROGENATION ANNEALING SHALL BE CARRIED OUT AS PER HW0640199.



COPYRIGHT AND CONFIDENTIAL. The information on this document is the property of BHARAT HEAVY ELECTRICALS LIMITED and shall not be used directly or indirectly in any way detrimental to the interest of the Company.

723.0-1120-115-a REF. DRG. No. 1724025/2023/HERP-PURCHASE SIGN & DATE

001	LINER IN TWO HALVES	AA1015227180	43	00	NO			
VAR 00	REMARKS	ITEM No.	DESCRIPTION	DRAWING No.	MATERIAL CODE	UNIT WEIGHT	LOS	ZONE
59	64	75	25	27	29	31	33	35
32	34	36	38	40	42	44	46	48

GRADE OF UNTOL DIM. —		MCG: — 1/M/1 AA 023 0208	
WELDING: — T1' O 610 003		GAS CUTTING: — T3' AA 0621101	
REV 01	DATE 27.5.02	ALTERED	CHECKED
REV 02	DATE 13/3/01	ALTERED	CHECKED
ZONE ELEVATION MODIFIED		ZONE B.O.M. DELETED. CBOM 011703 27000 WAS 4MS 011703 27000	

GMS No./GR-SP No. CBOM 011703 27000		STATUS OF DRG	
APPROVED	NAME	SIGN	DATE
MTE	C.B. SHARMA	[Signature]	19/04/24
STT	P. SINGH	[Signature]	18/04/24
TYPE OF PRODUCT OR NAME OF CUSTOMER/PROJECT		SHARAT HEAVY ELECTRICALS LTD.	
DRN	NAME	SIGN	DATE
CHD	P. ASHWIN	[Signature]	12/5/23
APPD	V.K. SINGH	[Signature]	14/5/24
DEPT	S.T.E.	SCALE	WEIGHT (KG)
02011		N.T.S.	43-00
TITLE		DRAWING No.	
LINER IN TWO HALVES		2-11703-27111	
CARD CODE		SHEET No. 01 No. OF SHEETS 01	



FIRST ANGLE PROJECTION

( ALL DIMENSIONS ARE IN mm )

FORM DG 38(B)

DRAWING No. 3-11703-27997

12.5  
▽ ALL OVER

COPYRIGHT AND CONFIDENTIAL  
 THE INFORMATION ON THIS DOCUMENT IS THE PROPERTY OF BHARAT HEAVY ELECTRICALS LIMITED. IT MUST NOT BE USED DIRECTLY OR INDIRECTLY IN ANY WAY DETERIMENTAL TO THE INTEREST OF THE COMPANY.

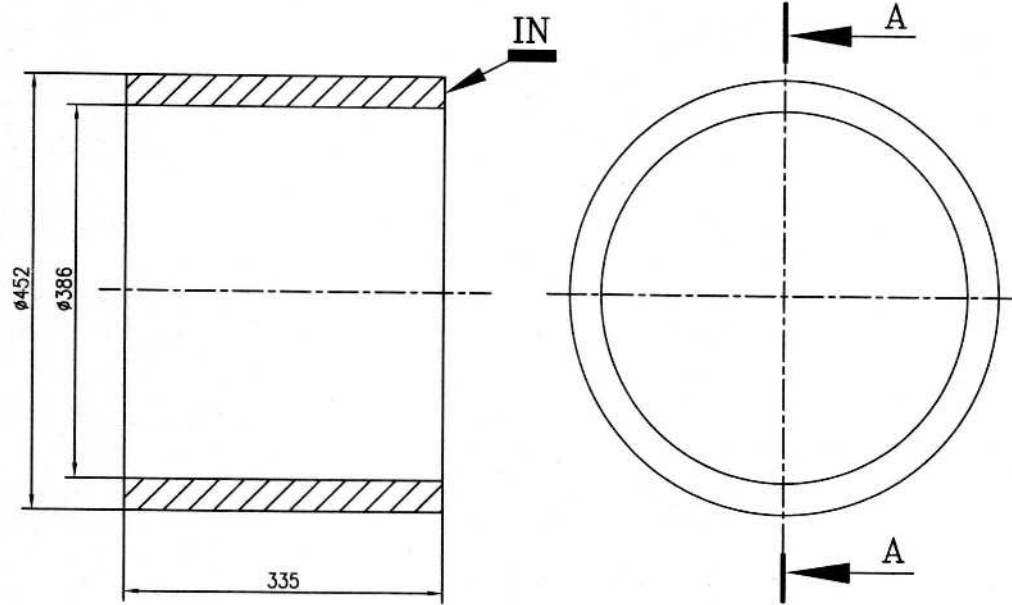

SECTION A-A

**TECHNICAL REQUIREMENTS:-**

- 1- FORGING SHALL BE SUPPLIED AS PER SPECIFICATION NO. AA19332.
- 2- TOLERANCES ON ALL THE DIMENSIONS  $\pm 1$ MM.
- 3- IDENTIFICATION MARKING ACCORDING TO HW0400397 AT THE PLACE IN
- 4- THE SUPPLIER SHALL LOCATE THE POSITION OF THE TEST SAMPLE AND GET IT APPROVED FROM BHEL. PART OF TEST SAMPLE SHALL BE SENT TO HEEP DULY IDENTIFIED FOR TESTING AT BHEL ALONG WITH FORGING.

21170327111 Ref. Drawing No.  
 Sign & Date  
 Inventory No.

		FORGING FOR LINER IN TWO HALVES (R/M)		3-11703-27997	W94311703066	115	00
VAR. 00	REMARKS	ITEM No.	DESCRIPTION		AA19332		
59	64 65	75 25 27	29	58 69 80	29 31 34 45	UNIT WEIGHT	72
CARD TYPE-3 28				CARD TYPE-1		CARD TYPE-2	
		MATERIAL CODE		58	(KG)	65	
		MATERIAL SPECN		54	55	66	71

GRADE OF UNTOL. DIM			
STE	AKASH S	-sd-	17.01.09
M/CG.-	AA0230208 m	TTX	S.SARKAR -sd- 17.01.09
WELDING-CLASS 'B' OF AA0621104			
GAS CUTTING-TABLE 3 OF AA0621101			

GMS No. / C B O M		STATUS OF DRG
01170327000		U
AGREED DEPT	NAME	SIGN DATE
STE	AKASH S	-sd- 17.01.09
TTX	S.SARKAR	-sd- 17.01.09

TYPE OF PRODUCT **STEAM TURBINE**  
 OR  
 NAME OF CUSTOMER/PROJECT

**BHARAT HEAVY ELECTRICALS LTD.**  
**RANIPUR, HARDWAR**

DRN	HIREN	-sd-	11.11.08	NO. OF VAR
CHD	ASHISH	-sd-	11.11.08	
APPD	JPM	-sd-	17.01.09	

DEPT	MTE	SCALE	WEIGHT (KG)	REF. TO ASSY. DRG.	ITEM No.	NO. OF ITEMS
CODE	4300	1:5	115.00	2-11703-27111		75 77

TITLE : **FORGING FOR LINER**  
 (ROUGH MACHINED)

CARD CODE 7  
 DRAWING NO. **3-11703-27997**  
 SHEET No. 1 No. OF SHEETS 1



COMBINED BILL OF MATERIAL

Printed On:27.09.2023

Printed By:

CBOM No: 01181418000 CBOM Var: 00  
 Description: JOURNAL BEARING D 450X425

Revno: 19

Rev Date: 28.07.2018

Total weight: 2650.68

17

RECORD OF CHANGES

Drawing No	Var	Revno	Rev Date	Description
01181418000	00	1	04.05.2001	Automatic chg 21181801027/02 21181801027/03, 21181801027/04
01181418000	00	2	16.03.2002	Automatic chg ST05010 /08
01181418000	00	5	05.08.2003	Automatic chg ST24002 /03
01181418000	00	6	17.07.2007	Automatic chg 01181418010/00
01181418000	00	7	13.09.2007	Automatic chg 11181821200/00
01181418000	00	8	14.09.2007	1.Change the matcode against drg.no.21181801053,item no.47 HW1060281198 in place of HW1060281090.
01181418000	00	9	03.10.2008	MAT. CODE HW1060281244 CHANGED TO HW1060273063 IN ITEM NO-55.
01181418000	00	10	04.12.2008	AUTOMATIC-BULK MATCODE CHG
01181418000	00	11	22.06.2009	Automatic chg 11181821200/00 ST02023 /11,
01181418000	00	12	28.06.2011	Auto Revision ST03003/056
01181418000	00	13	03.07.2012	1. FOR ITEM NO.10 SHIM QUANTITY CHANGED 1 TO 2. 2. FOR ITEM NO.12 13 & 14 SHIM QUANTITY 3 CHANGED TO 4.
01181418000	00	14	14.11.2014	item no.69 & 70 added.
01181418000	00	15	05.01.2015	Auto Revision 21181801027/05
01181418000	00	16	05.01.2015	Auto Revision 21181801027/05
01181418000	00	17	05.01.2015	Auto Revision ST05010/095
01181418000	00	18	05.01.2015	Auto Revision ST05010/095
01181418000	00	19	28.07.2018	Auto Revision 41160401051/00

HW-297.41

RB-092.00

	ENGG		JTE		MTE		TTX		WTX	
	Initial	Date	Initial	Date	Initial	Date	Initial	Date	Initial	Date
Worked By	sterkn	13.12.1999	jtedlb	25.02.2000	mtecbs	09.02.2000	ttxas	25.02.2000	wtxcbs	04.02.2000
Checked By	steas	31.01.2000	jtedlb	25.02.2000	mtecbs	09.02.2000	ttxas	25.02.2000	wtxbch	12.02.2000
Approved By	steakj	07.03.2000	jteskg	25.02.2000	mtejpm	09.02.2000	ttxdch	25.02.2000	wtxhpr	16.02.2000



ALL DIMENSIONS ARE IN MM

0-1814-18000

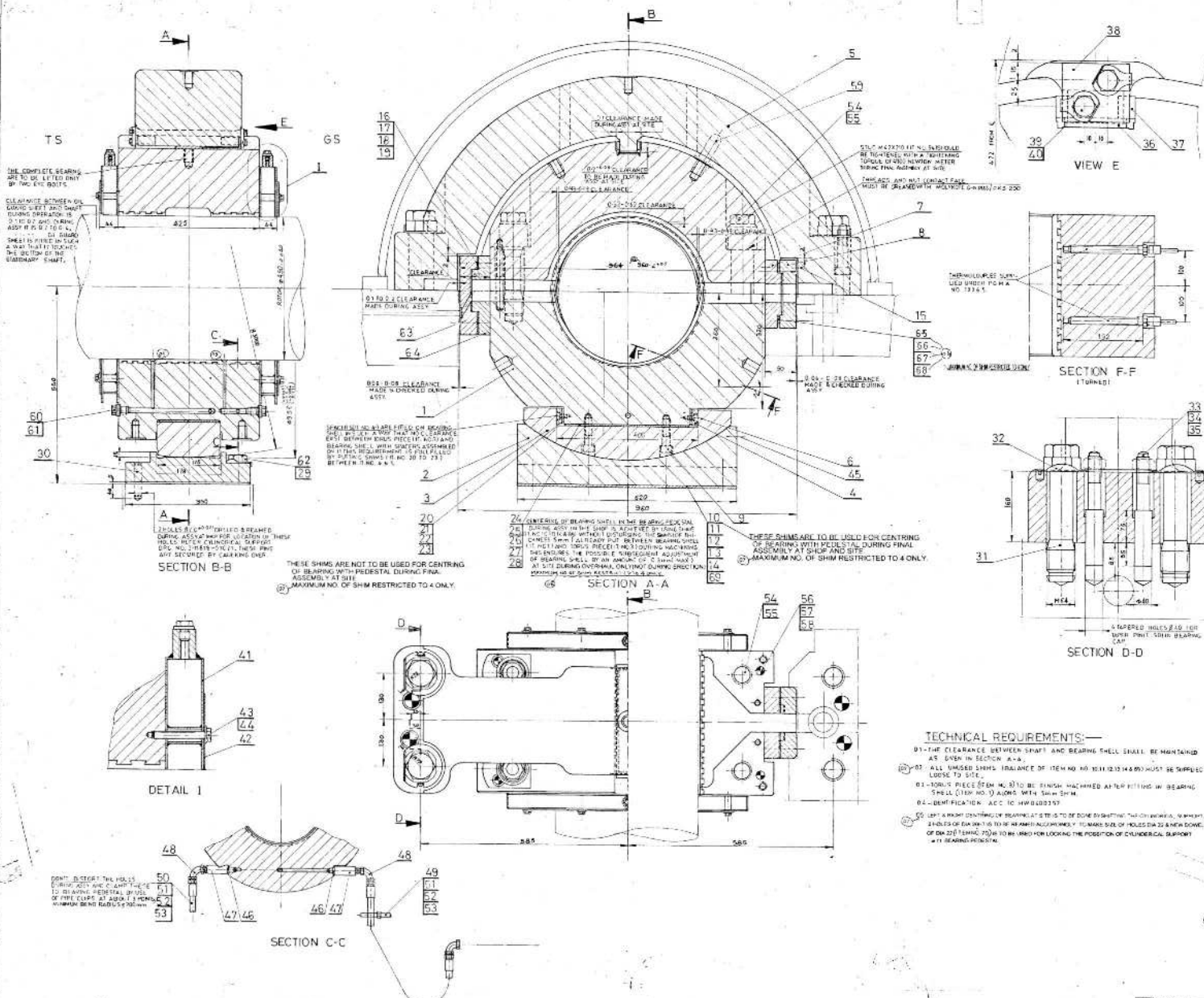

ITEM NO.	QTY	DESCRIPTION	UNIT	REMARKS
004	044	SHIM S-1.0	3-1180-01028	NW 107175518
004	052	SHIM S-0.2	3-1180-01028	MC 308161028
004	054	SHIM S-0.4	3-1180-01028	MC 308161028
004	056	SHIM S-0.6	3-1180-01028	MC 308161028
004	058	SHIM S-0.8	3-1180-01028	MC 308161028
001	064	SPACER	3-1180-01028	MC 308161028
001	065	SPACER	3-1180-01028	MC 308161028
001	066	SPACER	3-1180-01028	MC 308161028
002	067	SPACER	3-1180-01028	MC 308161028
002	068	SPACER	3-1180-01028	MC 308161028
002	069	SPACER	3-1180-01028	MC 308161028
002	070	SPACER	3-1180-01028	MC 308161028
002	071	SPACER	3-1180-01028	MC 308161028
002	072	SPACER	3-1180-01028	MC 308161028
002	073	SPACER	3-1180-01028	MC 308161028
002	074	SPACER	3-1180-01028	MC 308161028
002	075	SPACER	3-1180-01028	MC 308161028
002	076	SPACER	3-1180-01028	MC 308161028
002	077	SPACER	3-1180-01028	MC 308161028
002	078	SPACER	3-1180-01028	MC 308161028
002	079	SPACER	3-1180-01028	MC 308161028
002	080	SPACER	3-1180-01028	MC 308161028
002	081	SPACER	3-1180-01028	MC 308161028
002	082	SPACER	3-1180-01028	MC 308161028
002	083	SPACER	3-1180-01028	MC 308161028
002	084	SPACER	3-1180-01028	MC 308161028
002	085	SPACER	3-1180-01028	MC 308161028
002	086	SPACER	3-1180-01028	MC 308161028
002	087	SPACER	3-1180-01028	MC 308161028
002	088	SPACER	3-1180-01028	MC 308161028
002	089	SPACER	3-1180-01028	MC 308161028
002	090	SPACER	3-1180-01028	MC 308161028
002	091	SPACER	3-1180-01028	MC 308161028
002	092	SPACER	3-1180-01028	MC 308161028
002	093	SPACER	3-1180-01028	MC 308161028
002	094	SPACER	3-1180-01028	MC 308161028
002	095	SPACER	3-1180-01028	MC 308161028
002	096	SPACER	3-1180-01028	MC 308161028
002	097	SPACER	3-1180-01028	MC 308161028
002	098	SPACER	3-1180-01028	MC 308161028
002	099	SPACER	3-1180-01028	MC 308161028
002	100	SPACER	3-1180-01028	MC 308161028
002	101	SPACER	3-1180-01028	MC 308161028
002	102	SPACER	3-1180-01028	MC 308161028
002	103	SPACER	3-1180-01028	MC 308161028
002	104	SPACER	3-1180-01028	MC 308161028
002	105	SPACER	3-1180-01028	MC 308161028
002	106	SPACER	3-1180-01028	MC 308161028
002	107	SPACER	3-1180-01028	MC 308161028
002	108	SPACER	3-1180-01028	MC 308161028
002	109	SPACER	3-1180-01028	MC 308161028
002	110	SPACER	3-1180-01028	MC 308161028
002	111	SPACER	3-1180-01028	MC 308161028
002	112	SPACER	3-1180-01028	MC 308161028
002	113	SPACER	3-1180-01028	MC 308161028
002	114	SPACER	3-1180-01028	MC 308161028
002	115	SPACER	3-1180-01028	MC 308161028
002	116	SPACER	3-1180-01028	MC 308161028
002	117	SPACER	3-1180-01028	MC 308161028
002	118	SPACER	3-1180-01028	MC 308161028
002	119	SPACER	3-1180-01028	MC 308161028
002	120	SPACER	3-1180-01028	MC 308161028
002	121	SPACER	3-1180-01028	MC 308161028
002	122	SPACER	3-1180-01028	MC 308161028
002	123	SPACER	3-1180-01028	MC 308161028
002	124	SPACER	3-1180-01028	MC 308161028
002	125	SPACER	3-1180-01028	MC 308161028
002	126	SPACER	3-1180-01028	MC 308161028
002	127	SPACER	3-1180-01028	MC 308161028
002	128	SPACER	3-1180-01028	MC 308161028
002	129	SPACER	3-1180-01028	MC 308161028
002	130	SPACER	3-1180-01028	MC 308161028
002	131	SPACER	3-1180-01028	MC 308161028
002	132	SPACER	3-1180-01028	MC 308161028
002	133	SPACER	3-1180-01028	MC 308161028
002	134	SPACER	3-1180-01028	MC 308161028
002	135	SPACER	3-1180-01028	MC 308161028
002	136	SPACER	3-1180-01028	MC 308161028
002	137	SPACER	3-1180-01028	MC 308161028
002	138	SPACER	3-1180-01028	MC 308161028
002	139	SPACER	3-1180-01028	MC 308161028
002	140	SPACER	3-1180-01028	MC 308161028
002	141	SPACER	3-1180-01028	MC 308161028
002	142	SPACER	3-1180-01028	MC 308161028
002	143	SPACER	3-1180-01028	MC 308161028
002	144	SPACER	3-1180-01028	MC 308161028
002	145	SPACER	3-1180-01028	MC 308161028
002	146	SPACER	3-1180-01028	MC 308161028
002	147	SPACER	3-1180-01028	MC 308161028
002	148	SPACER	3-1180-01028	MC 308161028
002	149	SPACER	3-1180-01028	MC 308161028
002	150	SPACER	3-1180-01028	MC 308161028
002	151	SPACER	3-1180-01028	MC 308161028
002	152	SPACER	3-1180-01028	MC 308161028
002	153	SPACER	3-1180-01028	MC 308161028
002	154	SPACER	3-1180-01028	MC 308161028
002	155	SPACER	3-1180-01028	MC 308161028
002	156	SPACER	3-1180-01028	MC 308161028
002	157	SPACER	3-1180-01028	MC 308161028
002	158	SPACER	3-1180-01028	MC 308161028
002	159	SPACER	3-1180-01028	MC 308161028
002	160	SPACER	3-1180-01028	MC 308161028
002	161	SPACER	3-1180-01028	MC 308161028
002	162	SPACER	3-1180-01028	MC 308161028
002	163	SPACER	3-1180-01028	MC 308161028
002	164	SPACER	3-1180-01028	MC 308161028
002	165	SPACER	3-1180-01028	MC 308161028
002	166	SPACER	3-1180-01028	MC 308161028
002	167	SPACER	3-1180-01028	MC 308161028
002	168	SPACER	3-1180-01028	MC 308161028
002	169	SPACER	3-1180-01028	MC 308161028
002	170	SPACER	3-1180-01028	MC 308161028
002	171	SPACER	3-1180-01028	MC 308161028
002	172	SPACER	3-1180-01028	MC 308161028
002	173	SPACER	3-1180-01028	MC 308161028
002	174	SPACER	3-1180-01028	MC 308161028
002	175	SPACER	3-1180-01028	MC 308161028
002	176	SPACER	3-1180-01028	MC 308161028
002	177	SPACER	3-1180-01028	MC 308161028
002	178	SPACER	3-1180-01028	MC 308161028
002	179	SPACER	3-1180-01028	MC 308161028
002	180	SPACER	3-1180-01028	MC 308161028
002	181	SPACER	3-1180-01028	MC 308161028
002	182	SPACER	3-1180-01028	MC 308161028
002	183	SPACER	3-1180-01028	MC 308161028
002	184	SPACER	3-1180-01028	MC 308161028
002	185	SPACER	3-1180-01028	MC 308161028
002	186	SPACER	3-1180-01028	MC 308161028
002	187	SPACER	3-1180-01028	MC 308161028
002	188	SPACER	3-1180-01028	MC 308161028
002	189	SPACER	3-1180-01028	MC 308161028
002	190	SPACER	3-1180-01028	MC 308161028
002	191	SPACER	3-1180-01028	MC 308161028
002	192	SPACER	3-1180-01028	MC 308161028
002	193	SPACER	3-1180-01028	MC 308161028
002	194	SPACER	3-1180-01028	MC 308161028
002	195	SPACER	3-1180-01028	MC 308161028
002	196	SPACER	3-1180-01028	MC 308161028
002	197	SPACER	3-1180-01028	MC 308161028
002	198	SPACER	3-1180-01028	MC 308161028
002	199	SPACER	3-1180-01028	MC 308161028
002	200	SPACER	3-1180-01028	MC 308161028

**TECHNICAL REQUIREMENTS:**

- 01- THE CLEARANCE BETWEEN SHAFT AND BEARING SHELL SHALL BE MAINTAINED AS SHOWN IN SECTION A-A.
- 02- ALL UNUSED SHIMS IN PLACE OF ITEM NO. 001 TO 010 MUST BE SHIPPED LOOSE TO SITE.
- 03- ITEM NO. 001 SHALL BE FINISH MACHINED AFTER FITTING IN BEARING SHELL WITH 0.01mm TOLERANCE WITH SHIM SHOWN.
- 04- IDENTIFICATION ACC TO SHW 001003.
- 05- LEFT A RIGHT END OF BEARING AS TO BE DONE BY SIGNING THE OPERATOR, WHO MUST SIGN IN THE SPACE PROVIDED FOR THIS PURPOSE. THE SIZE OF HOLES IN THE BEARING SHELL SHALL BE MAINTAINED AS SHOWN IN SECTION A-A.
- 06- THE HOLES IN THE BEARING SHELL SHALL BE MAINTAINED AS SHOWN IN SECTION A-A.

REV	DATE	BY	CHKD	DESCRIPTION
001	17/01/2023	...	...	...
002	...	...	...	...
003	...	...	...	...
004	...	...	...	...
005	...	...	...	...
006	...	...	...	...
007	...	...	...	...
008	...	...	...	...
009	...	...	...	...
010	...	...	...	...
011	...	...	...	...
012	...	...	...	...
013	...	...	...	...
014	...	...	...	...
015	...	...	...	...
016	...	...	...	...
017	...	...	...	...
018	...	...	...	...
019	...	...	...	...
020	...	...	...	...
021	...	...	...	...
022	...	...	...	...
023	...	...	...	...
024	...	...	...	...
025	...	...	...	...
026	...	...	...	...
027	...	...	...	...
028	...	...	...	...
029	...	...	...	...
030	...	...	...	...
031	...	...	...	...
032	...	...	...	...
033	...	...	...	...
034	...	...	...	...
035	...	...	...	...
036	...	...	...	...
037	...	...	...	...
038	...	...	...	...
039	...	...	...	...
040	...	...	...	...
041	...	...	...	...
042	...	...	...	...
043	...	...	...	...
044	...	...	...	...
045	...	...	...	...
046	...	...	...	...
047	...	...	...	...
048	...	...	...	...
049	...	...	...	...
050	...	...	...	...
051	...	...	...	...
052	...	...	...	...
053	...	...	...	...
054	...	...	...	...
055	...	...	...	...
056	...	...	...	...
057	...	...	...	...
058	...	...	...	...
059	...	...	...	...
060	...	...	...	...
061	...	...	...	...
062	...	...	...	...
063	...	...	...	...
064	...	...	...	...
065	...	...	...	...
066	...	...		

SIGN & DATE 	संस्थान क्रय विनिर्देश (हीप - हर्द्वार) हरिद्वार)		HW12897	
	PLANT PURCHASE SPECIFICATION (HEEP - HARDWAR)		पृष्ठ Page 1	का of 3

SUPERSEDES INVENTORY NO.  
 TLV 9977/02 Nov '01  
 COPYRIGHT AND CONFIDENTIAL  
 The information on this document is the property of Bharat Heavy Electrical Limited. It must not be used directly or indirectly in any way detrimental to the interest of the company.

**Special Tin Based Antifriction Bearing Alloy**

1/3

- General:**  
 This specification governs the requirements of tin based antifriction bearing alloy.
- Application:**  
 For Babbitt lining of journal and thrust bearings on cast iron and cast/forged steel bearings shells.
- Condition of Delivery:** As cast ingots.
- Dimension & Tolerances:**  
 Weight of each ingot shall not be more than 3kg.
- Freedom from Defects:**  
 The ingots shall be homogeneous and free from non-metallic inclusions and shall have smooth appearance.
- Manufacture:**  
 The babbitt alloy shall be manufactured from virgin metals only. Return scrap shall not be used. The manufacturer shall take all precautions to ensure proper mixing of the alloying elements and the melt homogeneous.
- Chemical Composition (weight %):**  
 The chemical composition of the Babbitt when analysed in accordance with IS:1409 (methods of chemical analysis of antifriction bearing alloy) or by any other conventional / instrumental method shall be as follows:

Sn	Cd	Cu	Sb	Ni	As	Pb	Fe	Zn	Al
80.0 - 81.9	1.0 - 1.4	5.0 - 5.5	11.0 - 13.0	0.20 - 0.50	0.30 - 0.70	< 0.06	≤ 0.01	≤ 0.02	≤ 0.02

Alternatively, Babbitt as per below mentioned chemistry is also acceptable.

Sn	Sb	Cu	Ag	Cd	Ni	Bi	As	Pb	Fe	Zn	Al
Rest	11.0 - 13.0	5.5 - 6.5	0.05 - 0.15	< 0.03	< 0.06	< 0.06	< 0.06	< 0.06	< 0.03	0.5 - 0.7	< 0.01

स्वत्वाधिकार एवं गोपनीय  
 इस दस्तावेज में दी गई सूचना भारत भारती इलेक्ट्रिकल्स की संपत्ति है। इसका प्रकाश एवं प्रसारण रूप में किसी भी प्रकार प्रयोग, जो कि किसी भी रूप में स्वत्वाधिकार को नष्ट करता है।

INVENTORY NO.  
 P-3061  
 30/9/12

TSX R. VARMA QAX SUGANDH AGARWAL IPSC VK Chauhan STE D K RAY AGREED DEPT NAME DATE & SIGNATURE	[Signature] [Signature] [Signature] [Signature] [Signature]	नाम NAME Ashish.Ranjan T S Gopalkrishnan J.P.Meena	दिनांक एवं हस्ताक्षर SIGNATURE & DATE 7.9.12 7.9.12 8/9/12
स्वीकृति : संस्थान मानक समिति APPROVED : PLANT STANDARDS COMMITTEE		Gp.No. 2.65	
Rev. No. 05 Dt. 07.09.2012	जारी मानक विभाग ISSUED : STANDARDS DIVISION	दिनांक : DATE : 19.08.88	

निर्माण एवं दिनांक SIGN & DATE		<b>संस्थान क्रय विनिर्देश (हीप - हार्डवार)</b>	<b>HW12897</b>	
SUPERSIDES INVENTORY NO	<b>PLANT PURCHASE SPECIFICATION (HEEP - HARDWAR)</b>		पृष्ठ का	Page 2 of 3
स्वत्वाधिकार एवं गोपनीय <small>यदि उपरोक्त में कोई त्रुटि पाया जाए तो हीप निर्माणकर्ता को सूचित कर देना चाहिए। इसका प्रस्ताव एवं अंतिम रूप में तैयारी भी उपरोक्त में ही की जानी चाहिए।</small>	<b>8. Fracture Test:</b>			
The fracture surfaces of the ingots when broken at notches shall not show segregation, dross, dirt, spots, overheated metal or any other type of non-metallic inclusions and shall show a fine grain structure.				
<b>9. Test Samples:</b>				
<ul style="list-style-type: none"> <li>Chemical analysis shall be reported on each heat basis.</li> <li>Per heat a minimum of two ingots shall be taken for fracture test.</li> </ul>				
<b>10. Retest:</b>				
If any of the selected test samples fail to meet the specified requirement, two additional test samples shall be selected for re-testing without any further treatment and both of these samples should pass for acceptance. All tests shall be repeated at BHEL to verify manufacturer's test results.				
<b>11. Inspection at Supplier Works:</b>				
BHEL representative shall have all reasonable facilities afforded to him at any time by the supplier to satisfy himself that the material is being furnished in accordance with this specification. Cutting, marking and testing of test samples may be witnessed by BHEL representative/customer's representative at supplier's works.				
<b>12. Test Certificate:</b>				
The supplier shall be submit five copies of the test certificate giving the following information's:				
<ul style="list-style-type: none"> <li>BHEL Order No.</li> <li>Purchase specification No.</li> <li>Supplier's reference and Name</li> <li>Results of chemical analysis</li> <li>Fracture Test Results</li> <li>Heat No.</li> <li>Consignment / identification No.</li> </ul>				
<b>13.0 Marking:</b>				
Ingot shall be clearly marked with the Maker's brand either stamped or cast in with following details:				
<ul style="list-style-type: none"> <li>BHEL order number</li> <li>Purchase specification number</li> <li>Supplier's reference and Name</li> <li>Results of chemical analysis</li> <li>Heat No.</li> <li>Weight</li> <li>Consignment / Identification No.</li> </ul>				
निर्माण एवं दिनांक SIGN & DATE	Rev.No.05	निर्माणकर्ता WORKED BY	Ashish Ranjan	28.03.11
निर्माण एवं दिनांक SIGN & DATE	Rev.No.05	जांचकर्ता CHECKED BY	Gopal Krishnan	28.03.11
निर्माण एवं दिनांक SIGN & DATE	Rev.No.05	निर्माणकर्ता WORKED BY	Ashish Ranjan	28.03.11
निर्माण एवं दिनांक SIGN & DATE	Rev.No.05	जांचकर्ता CHECKED BY	Gopal Krishnan	28.03.11

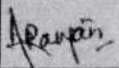
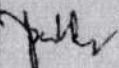
निर्माण का अंश SIGN & DATE		संस्थान क्रय विनिर्देश (हीप - हरिद्वार)  <b>PLANT PURCHASE SPECIFICATION</b> (HEEP - HARDWAR)	<b>HW12897</b> पृष्ठ का Page 3 of 3
SUPERSEDES INVENTORY NO.	<b>14.0 Rejection &amp; Replacement:</b> In the event of material proving defective in the course of melting and casting, such material shall stand rejected, not withstanding any previous certification of satisfactory testing inspection. The supplier shall undertake to replace the materials free of charge without any delay and arrange to take back the rejected material as own cost.		
स्वत्-धिकार पूर्व गोपनीय इस प्रलेख में हीप, हीप - हरिद्वार का स्वत्-धिकार है। इसका प्रयोग एवं प्रसारण के बिना हीप - हरिद्वार के बिना कभी भी नहीं किया जा सकता है।	<b>15.0 Cross Referred Standard: IS: 1409</b>		
निर्माण का अंश SIGN & DATE  20/03/11			
सामग्री का संख्या INVENTORY NO. P-3061	Rev.No.05	निर्माणकर्ता WORKED BY Ashish Ranjan	 28.03.11
		जांचकर्ता CHECKED BY Gopal Krishnan	 28.3.11

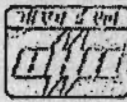
FORM NO. & EDITION SIGN & DATE		<b>संस्थान मानक (टीप - हार्डवयर)</b>  <b>PLANT STANDARD (HEEP - HARDWAR)</b>	<b>HW 0850195</b> पृष्ठ का Page 1 of 11
SUPERVISOR INVENTORY NO.	<b>NON DESTRUCTIVE TESTING OF NEWLY MANUFACTURED (KWU DESIGN) BEARING AND THRUST BEARING PADS MADE OF STEEL</b>  Based on: PV 0068 Nov, 2002		
नाम एवं पता उद्योग का है	<b>List of Contents</b>		
<b>COPYRIGHT AND CONFIDENTIAL</b> <small>The information on this document is the property of Bharat Heavy Electricals Limited. It must not be reproduced or indirectly or any way detrimental to the interest of the company.</small>	<b>Page No.</b>		
<b>सत्यापक एवं मोदीय</b> <small>अनुमोदित करने वाले व्यक्ति का नाम (अनुमोदक) और तारीख (अनुमोदक) का उल्लेख करना आवश्यक है।</small>	<b>Page No.</b>		
नाम & DATE <b>4/10/08</b>	<b>TSX</b> <b>B. CHOUDHARY</b>	नाम <b>NAME</b>	तारीख & हस्ताक्षर <b>SIGNATURE &amp; DATE</b>
<b>P-3041</b>	<b>STE</b> <b>D.K. RAY</b>	हस्ताक्षर <b>SIGNATURE</b>	तारीख & हस्ताक्षर <b>DATE &amp; SIGNATURE</b>
<b>28-10-08</b>	<b>EME</b> <b>R.C. Sharma</b>	तारीख <b>DATE</b>	हस्ताक्षर <b>SIGNATURE</b>
	<b>WG-NDT</b> Sh. A.K. Sharma	तारीख <b>DATE</b>	हस्ताक्षर <b>SIGNATURE</b>
	<b>QAX</b> <b>N.K. Manwani</b>	तारीख <b>DATE</b>	हस्ताक्षर <b>SIGNATURE</b>
	<b>MTT</b> <b>ASHISH</b>	तारीख <b>DATE</b>	हस्ताक्षर <b>SIGNATURE</b>
	<b>AGREED DEPT I</b> NAME	तारीख <b>DATE</b>	हस्ताक्षर <b>SIGNATURE</b>
	<b>संस्थान मानक समिति</b> <b>APPROVED: PLANT STANDARDS COMMITTEE</b>		
	संख्या <b>Rev 02</b>	तारीख <b>28-10-08</b>	हस्ताक्षर <b>6.48</b>
	तैयार <b>PREPARED: MRL</b>	जारी <b>ISSUED: STANDARDS DIVISION</b>	तारीख <b>DATE: 01-04-1988</b> <b>2008</b>

12/7/08  
10/7/08

SHEET NO. / REVISION DATE		संस्थान मानक (डीप - हरिद्वार) <b>PLANT STANDARD (HEEP - HARDWAR)</b>	<b>HW 0850195</b> पृष्ठ का Page 2 of 11	
SPECIFICATIONS DEPARTMENT NO.	<p><b>1. Scope</b></p> <p>This test procedure is applicable for non destructive testing of new or repaired (completely rebabbited) radial sliding bearings, thrust bearing pads and seal rings used in steam turbines and turbo generators.</p> <p>This test procedure shall be used for the determination of non-bonding defects</p> <p>a) Between the bearing metal and the base metal and also surface defects in the sliding surface of the bearing.</p> <p>b) Between bearing metal &amp; support and surface defects in contact surface of seal rings.</p> <p>This procedure lays down the procedures for performing dye penetrant testing (OPT) and Ultrasonic Testing (UT) and the acceptance norms.</p>			
COPYRIGHT AND CONFIDENTIAL The information in this document is the property of Bharat Heavy Electrical Limited and must not be used without the prior written permission of the Director of the concern.	<p><b>2. Qualification of Testing Personnel</b></p> <p>The testing personnel shall be qualified as per ASNT/ISNT Level -I for dye penetrant testing and Ultrasonic Testing. Final evaluation is to be done by level II personnel.</p> <p><b>3. Extent &amp; Stage of Test</b></p> <p>1.1 After babbiting &amp; rough machining:</p> <p>a) Ultrasonic Testing of the bearing bore in case of bearings</p> <p>b) Ultrasonic testing of the bearing surface TB pads.</p> <p>c) Ultrasonic Testing of the bearing surface and end faces of seal rings.</p> <p>1.2 After final machining: Dye penetrant testing &amp; ultrasonic testing of the babbitted surface areas shall be done.</p> <p>1.3 After additional final machining: If final machining is completed after delivery (i.e. spare bearing) dye penetrant testing must be repeated.</p> <p><b>4. Surface Condition</b></p> <p>The test areas must be free of grease and other contaminants which impair the test. The scanning surface for ultrasonic testing shall not have undulations and tool marks which affect the interpretation of indications.</p> <p>Surface finish <math>R_z \leq 40\mu m</math> for rough machined bearings and bearing surface of seal rings.          Surface finish <math>R_z \leq 16 \mu m</math> for end faces of seal rings.</p> <p>(For finish machined bearings, the surface finish will be as per drawing).</p>			
सहायिका एवं योजना 10/11/2023				
प्रमाणित S.D. & D.A.H.				
INVENTORY NO. <b>P-3041</b>	REV. NO. 02		कार्यवाही WORKED BY Sh Kamal Sehgal Kamal Sehgal	
			जांच CHECKED BY Sh Virek Mittal Virek Mittal	MRL

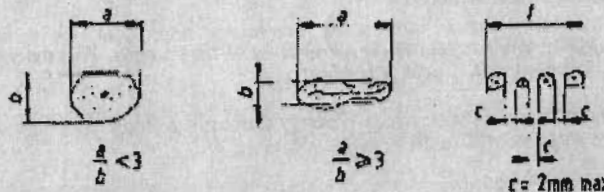
1723003/2023/HERP-MARCHASE		<b>संस्थान मानक (डीप - हरिद्वार)</b> <b>PLANT STANDARD (HEEP - HARDWAR)</b>	<b>HW 0850195</b> पृष्ठ का Page 3 of 11
1723003/2023/HERP-MARCHASE	1723003/2023/HERP-MARCHASE	<p><b>5. Dye Penetration Testing</b></p> <p><b>5.1 Test Parameters</b></p> <p>The DP testing shall be conducted in accordance with corporate specification AA0850131 using visible dye penetrant. The penetrant, cleaner and developer should match each other. The penetration time shall be between 10-60 minutes.</p> <p>The interpretation of results commences directly after drying of developer. Final evaluation shall be done after at least 10 minutes of developing time. The observations are to be recorded in the test certificate.</p> <p><b>5.2 Assessment of the Results and Acceptance Criteria</b></p> <p>There are no different test classes or areas for Dye penetrant testing. The various types of indications observed in Dye penetrant testing may be classified as shown in Fig. 1</p> <div style="text-align: center;">  </div> <p>Fig 1: a) Circular Indication      b) linear indication      c) linearly aligned indication</p> <p><b>Acceptance Criteria</b></p> <p>The indications except following are acceptable:</p> <ol style="list-style-type: none"> <li>No circular indications with <math>a &gt; 4\text{mm}</math>. (As defined in Fig 1a)</li> <li>No linear indication. (As defined in Fig 1-b)          Linear marks: between the bearing backing/bearing material on the end faces; or joint faces of multilayer plain bearing is only relevant if found by ultrasonic testing. In that case ultrasonic acceptance criteria shall be applicable.</li> <li>No linearly aligned indications. (as defined in Fig. 1-c)</li> <li>No more than four indications, with a maximum total area of <math>16\text{mm}^2</math> in area of <math>10,000\text{mm}^2</math>. The surface tested may be square or rectangular, with a maximum side length of 250 mm. The defective area considered for evaluation shall be the worst affected area of the total surface under examination.</li> </ol> <p>Clause a) to d) is applicable for DP testing of bearing and thrust bearing pads.          Clause a) to c) is applicable for DP testing of seal rings.</p>	
1723003/2023/HERP-MARCHASE	1723003/2023/HERP-MARCHASE	1723003/2023/HERP-MARCHASE	1723003/2023/HERP-MARCHASE
1723003/2023/HERP-MARCHASE	1723003/2023/HERP-MARCHASE	1723003/2023/HERP-MARCHASE	1723003/2023/HERP-MARCHASE
1723003/2023/HERP-MARCHASE	1723003/2023/HERP-MARCHASE	1723003/2023/HERP-MARCHASE	1723003/2023/HERP-MARCHASE
1723003/2023/HERP-MARCHASE	1723003/2023/HERP-MARCHASE	1723003/2023/HERP-MARCHASE	1723003/2023/HERP-MARCHASE
1723003/2023/HERP-MARCHASE	1723003/2023/HERP-MARCHASE	1723003/2023/HERP-MARCHASE	1723003/2023/HERP-MARCHASE
1723003/2023/HERP-MARCHASE	1723003/2023/HERP-MARCHASE	1723003/2023/HERP-MARCHASE	1723003/2023/HERP-MARCHASE
1723003/2023/HERP-MARCHASE	1723003/2023/HERP-MARCHASE	1723003/2023/HERP-MARCHASE	1723003/2023/HERP-MARCHASE
1723003/2023/HERP-MARCHASE	1723003/2023/HERP-MARCHASE	1723003/2023/HERP-MARCHASE	1723003/2023/HERP-MARCHASE
1723003/2023/HERP-MARCHASE	1723003/2023/HERP-MARCHASE	1723003/2023/HERP-MARCHASE	1723003/2023/HERP-MARCHASE
1723003/2023/HERP-MARCHASE	1723003/2023/HERP-MARCHASE	1723003/2023/HERP-MARCHASE	1723003/2023/HERP-MARCHASE
1723003/2023/HERP-MARCHASE	1723003/2023/HERP-MARCHASE	1723003/2023/HERP-MARCHASE	1723003/2023/HERP-MARCHASE
1723003/2023/HERP-MARCHASE	1723003/2023/HERP-MARCHASE	1723003/2023/HERP-MARCHASE	1723003/2023/HERP-MARCHASE
1723003/2023/HERP-MARCHASE	1723003/2023/HERP-MARCHASE	1723003/2023/HERP-MARCHASE	1723003/2023/HERP-MARCHASE
1723003/2023/HERP-MARCHASE	1723003/2023/HERP-MARCHASE	1723003/2023/HERP-MARCHASE	1723003/2023/HERP-MARCHASE
1723003/2023/HERP-MARCHASE	1723003/2023/HERP-MARCHASE	1723003/2023/HERP-MARCHASE	1723003/2023/HERP-MARCHASE
1723003/2023/HERP-MARCHASE	1723003/2023/HERP-MARCHASE	1723003/2023/HERP-MARCHASE	1723003/2023/HERP-MARCHASE
1723003/2023/HERP-MARCHASE	1723003/2023/HERP-MARCHASE	1723003/2023/HERP-MARCHASE	1723003/2023/HERP-MARCHASE
1723003/2023/HERP-MARCHASE	1723003/2023/HERP-MARCHASE	1723003/2023/HERP-MARCHASE	1723003/2023/HERP-MARCHASE
1723003/2023/HERP-MARCHASE	1723003/2023/HERP-MARCHASE	1723003/2023/HERP-MARCHASE	1723003/2023/HERP-MARCHASE
1723003/2023/HERP-MARCHASE	1723003/2023/HERP-MARCHASE	1723003/2023/HERP-MARCHASE	1723003/2023/HERP-MARCHASE
1723003/2023/HERP-MARCHASE	1723003/2023/HERP-MARCHASE	1723003/2023/HERP-MARCHASE	1723003/2023/HERP-MARCHASE
1723003/2023/HERP-MARCHASE	1723003/2023/HERP-MARCHASE	1723003/2023/HERP-MARCHASE	1723003/2023/HERP-MARCHASE
1723003/2023/HERP-MARCHASE	1723003/2023/HERP-MARCHASE	1723003/2023/HERP-MARCHASE	1723003/2023/HERP-MARCHASE
1723003/2023/HERP-MARCHASE	1723003/2023/HERP-MARCHASE	1723003/2023/HERP-MARCHASE	1723003/2023/HERP-MARCHASE
1723003/2023/HERP-MARCHASE	1723003/2023/HERP-MARCHASE	1723003/2023/HERP-MARCHASE	1723003/2023/HERP-MARCHASE
1723003/2023/HERP-MARCHASE	1723003/2023/HERP-MARCHASE	1723003/2023/HERP-MARCHASE	1723003/2023/HERP-MARCHASE
1723003/2023/HERP-MARCHASE	1723003/2023/HERP-MARCHASE	1723003/2023/HERP-MARCHASE	1723003/2023/HERP-MARCHASE
1723003/2023/HERP-MARCHASE	1723003/2023/HERP-MARCHASE	1723003/2023/HERP-MARCHASE	1723003/2023/HERP-MARCHASE
1723003/2023/HERP-MARCHASE	1723003/2023/HERP-MARCHASE	1723003/2023/HERP-MARCHASE	1723003/2023/HERP-MARCHASE
1723003/2023/HERP-MARCHASE	1723003/2023/HERP-MARCHASE	1723003/2023/HERP-MARCHASE	1723003/2023/HERP-MARCHASE
1723003/2023/HERP-MARCHASE	1723003/2023/HERP-MARCHASE	1723003/2023/HERP-MARCHASE	1723003/2023/HERP-MARCHASE
1723003/2023/HERP-MARCHASE	1723003/2023/HERP-MARCHASE	1723003/2023/HERP-MARCHASE	1723003/2023/HERP-MARCHASE
1723003/2023/HERP-MARCHASE	1723003/2023/HERP-MARCHASE	1723003/2023/HERP-MARCHASE	1723003/2023/HERP-MARCHASE
1723003/2023/HERP-MARCHASE	1723003/2023/HERP-MARCHASE	1723003/2023/HERP-MARCHASE	1723003/2023/HERP-MARCHASE
1723003/2023/HERP-MARCHASE	1723003/2023/HERP-MARCHASE	1723003/2023/HERP-MARCHASE	1723003/2023/HERP-MARCHASE
1723003/2023/HERP-MARCHASE	1723003/2023/HERP-MARCHASE	1723003/2023/HERP-MARCHASE	1723003/2023/HERP-MARCHASE
1723003/2023/HERP-MARCHASE	1723003/2023/HERP-MARCHASE	1723003/2023/HERP-MARCHASE	1723003/2023/HERP-MARCHASE
1723003/2023/HERP-MARCHASE	1723003/2023/HERP-MARCHASE	1723003/2023/HERP-MARCHASE	1723003/2023/HERP-MARCHASE
1723003/2023/HERP-MARCHASE	1723003/2023/HERP-MARCHASE	1723003/2023/HERP-MARCHASE	1723003/2023/HERP-MARCHASE
1723003/2023/HERP-MARCHASE	1723003/2023/HERP-MARCHASE	1723003/2023/HERP-MARCHASE	1723003/2023/HERP-MARCHASE
1723003/2023/HERP-MARCHASE	1723003/2023/HERP-MARCHASE	1723003/2023/HERP-MARCHASE	1723003/2023/HERP-MARCHASE
1723003/2023/HERP-MARCHASE	1723003/2023/HERP-MARCHASE	1723003/2023/HERP-MARCHASE	1723003/2023/HERP-MARCHASE
1723003/2023/HERP-MARCHASE	1723003/2023/HERP-MARCHASE	1723003/2023/HERP-MARCHASE	1723003/2023/HERP-MARCHASE
1723003/2023/HERP-MARCHASE	1723003/2023/HERP-MARCHASE	1723003/2023/HERP-MARCHASE	1723003/2023/HERP-MARCHASE
1723003/2023/HERP-MARCHASE	1723003/2023/HERP-MARCHASE	1723003/2023/HERP-MARCHASE	1723003/2023/HERP-MARCHASE
1723003/2023/HERP-MARCHASE	1723003/2023/HERP-MARCHASE	1723003/2023/HERP-MARCHASE	1723003/2023/HERP-MARCHASE
1723003/2023/HERP-MARCHASE	1723003/2023/HERP-MARCHASE	1723003/2023/HERP-MARCHASE	1723003/2023/HERP-MARCHASE
1723003/2023/HERP-MARCHASE	1723003/2023/HERP-MARCHASE	1723003/2023/HERP-MARCHASE	1723003/2023/HERP-MARCHASE
1723003/2023/HERP-MARCHASE	1723003/2023/HERP-MARCHASE	1723003/2023/HERP-MARCHASE	1723003/2023/HERP-MARCHASE
1723003/2023/HERP-MARCHASE	1723003/2023/HERP-MARCHASE	1723003/2023/HERP-MARCHASE	1723003/2023/HERP-MARCHASE
1723003/2023/HERP-MARCHASE	1723003/2023/HERP-MARCHASE	1723003/2023/HERP-MARCHASE	1723003/2023/HERP-MARCHASE
1723003/2023/HERP-MARCHASE	1723003/2023/HERP-MARCHASE	1723003/2023/HERP-MARCHASE	1723003/2023/HERP-MARCHASE
1723003/2023/HERP-MARCHASE	1723003/2023/HERP-MARCHASE	1723003/2023/HERP-MARCHASE	1723003/2023/HERP-MARCHASE
1723003/2023/HERP-MARCHASE	1723003/2023/HERP-MARCHASE	1723003/2023/HERP-MARCHASE	1723003/2023/HERP-MARCHASE
1723003/2023/HERP-MARCHASE	1723003/2023/HERP-MARCHASE	1723003/2023/HERP-MARCHASE	1723003/2023/HERP-MARCHASE
1723003/2023/HERP-MARCHASE	1723003/2023/HERP-MARCHASE	1723003/2023/HERP-MARCHASE	1723003/2023/HERP-MARCHASE
1723003/2023/HERP-MARCHASE	1723003/2023/HERP-MARCHASE	1723003/2023/HERP-MARCHASE	1723003/2023/HERP-MARCHASE
1723003/2023/HERP-MARCHASE	1723003/2023/HERP-MARCHASE	1723003/2023/HERP-MARCHASE	1723003/2023/HERP-MARCHASE
1723003/2023/HERP-MARCHASE	1723003/2023/HERP-MARCHASE	1723003/2023/HERP-MARCHASE	1723003/2023/HERP-MARCHASE
1723003/2023/HERP-MARCHASE			

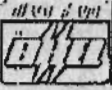
REVISIONS संस्था मानक (डीप - हरिद्वार)		<b>संस्था मानक (डीप - हरिद्वार)</b> <b>PLANT STANDARD (HELP-HARDWAR)</b>	<b>HW 0850195</b> पृष्ठ का Page 4 of 11										
MATERIALS सामग्री	<b>6.2.1 Micro porosity</b> <p>Directly after drying of the developer, observe whether individual indications of size greater than 1.5mm are seen. If so, there must be evaluated as per clause 5.2 a-(d).</p> <p>If the indications are smaller than 1.5 mm, they may be classified as micro porosity, they could lie very close together so that at end of the developing period the whole surface becomes red and distinction of individual defects is no longer possible.</p> <p>If this happens the test surface must be cleaned and examined for visible pores. If no pores are visible without the aid of a magnifying glass then they can be classified as micro porosity.</p> <p>Pores up to a size of 1.0mm visible to the naked eye, are acceptable, if they appear isolated with no linear character with a gap of <math>\geq 2</math> mm from each other. A maximum of four indications in an area of 10,000 mm<sup>2</sup> are acceptable in the worst affected area of the total surface under examination.</p> <p>The feasibility of UT must not be affected by micro porosity. This means bond echoes must be visible in areas with micro porosity.</p> <p>In addition the areas with micro porosity must not exceed 30% of each bearing half and must not show any UT related bonding defects.</p>												
COPYRIGHT AND CONFIDENTIAL कॉपीराइट और गोपनीय	<b>6. Ultrasonic Test</b> <b>6.1 Test Equipment and Probes</b> <b>6.1.1 Ultrasonic test device:</b> For testing, the ultrasonic equipment shall be such that it conforms to the requirements of corporate standard AA 0850159. <b>6.1.2 Probes:</b> The size, frequency and type of probe shall be chosen in relation to the thickness of the bearing layer, backing thickness and backing material. (Ref: Table 1) For babbitt thickness greater than 6 mm, a probe of frequency 2 MHz shall be used. If the bearing diameter is less than or equal to 600 mm, the probe used must have a diameter less than or equal to 10 mm.												
DATE दिनांक	Table 1 <table border="1" style="width:100%; border-collapse: collapse; text-align: center;"> <thead> <tr> <th>Bearing metal thickness (mm)</th> <th>Backing thickness (steel) (mm)</th> <th>Probe diameter (mm)</th> <th>Probe frequency (MHz)</th> <th>Probe type</th> </tr> </thead> <tbody> <tr> <td>&gt;2</td> <td>20 to 250</td> <td>10 to 30</td> <td>2 to 5</td> <td>Single crystal</td> </tr> </tbody> </table>			Bearing metal thickness (mm)	Backing thickness (steel) (mm)	Probe diameter (mm)	Probe frequency (MHz)	Probe type	>2	20 to 250	10 to 30	2 to 5	Single crystal
Bearing metal thickness (mm)	Backing thickness (steel) (mm)	Probe diameter (mm)	Probe frequency (MHz)	Probe type									
>2	20 to 250	10 to 30	2 to 5	Single crystal									
INVENTORY NO. P-3041	REV. NO. 02		Prepared WORKED BY Sh. Kamal Sehgal Checked CHECKED BY Sh. Vivek Mittal DGM MRL										

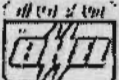
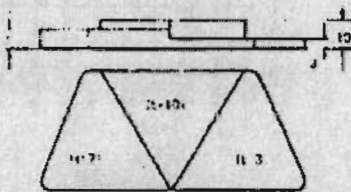
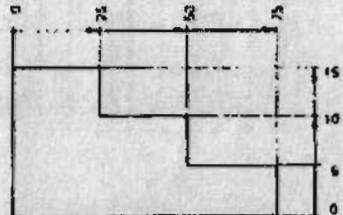
संस्था का नाम SHRI LAXMI संस्था का पता ... संस्था का फोन नं. ...		संस्थान मानक (डीप - हार्डवेयर) <b>PLANT STANDARD (DEEP - HARDWARE)</b>	<b>HW 0850195</b> पृष्ठ का Page 5 of 11
<b>6.2 Setting Sensitivity</b> The distance calibration and sensitivity setting is to be carried out by test block as shown in Fig 2 & 3. These blocks must be of the same material and have the same thickness <sup>1</sup> as the babbitt layer being tested and be free from defects			
<div style="display: flex; justify-content: space-around;">   </div>			
<sup>1</sup> Dimensional tolerances for test blocks: -25 % for bearing metal thickness less than/equal to 3 mm. +/- 20% for bearing metal thickness greater than 3 mm.			
<b>6.2.1 Equipment Setting</b> The testing is done without using job back wall echo but using a test block. The time base range of the instrument shall be so adjusted so that at least three multiple back wall echoes (RE) are obtained from a suitable reference block, on the screen.			
The first back wall echo (RE) from the test block is set to 80 % of the screen height. Figs 4 to 7 show the echo patterns for good & bad bond while using a single crystal probe. For scanning the curved surfaces the sensitivity is to be increased by 6 dB. (Difference between plain surface of the reference piece and curvature of the bearing).			
<b>6.2.2 Recording Level</b> The recordable level is 50% of the screen height of the first bond echo. However, if an indication exceeds 50% of the screen height by 5-10% and does not have any multiples, then this does not have to be recorded. For Seal Rings, the extent of recordable indications shall be determined only in circumferential direction of the seal ring by moving the probe in the area within which the bonding echo exceeds 50 % of full screen height. The distance measured in the circumferential direction shall be designated as the recording length and shall be recorded.			
Indications with extent are those indications, length of which exceed the probe diameter. Point Indications are those indications, length of which are less than probe diameter. For indications with extent, the distance measured in the circumferential length shall be recorded as the defect length. For point defects, half of probe diameter shall be taken as defect length.			
INVENTORY P-3041	REV. NO. 02	...	Prepared by WORKED BY Sh. Kamal Sehgal Kamal Sehgal Checked by Sh. Vinod Mittal Vinod Mittal DGM MRL

COPYRIGHT AND CONFIDENTIAL

संस्थाधिकार एवं गोपनीय

SIGN & DATE

4/10/08





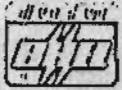
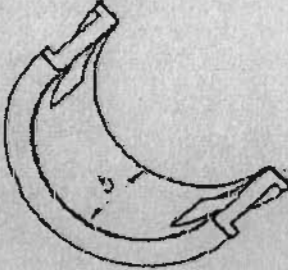
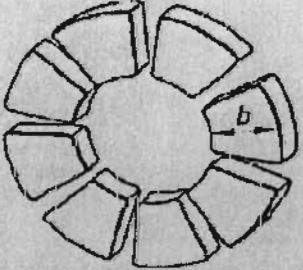

संस्था का प्रमुख संस्था का नाम संस्था का पता		संस्थान मानक (डीप - हरिद्वार) <b>PLANT STANDARD (JEEP - HARDWAR)</b>	<b>HW 0850195</b> पृष्ठ का Page 9 of 11
निकाशिका निकाशिका नं. निकाशिका का पता	<p>X= 100% no bond allowed on the Al-Bronze washer (shown as X in the above sketch)</p> <p>The <b>TEST ZONE 1</b> is defined as the crosshatched area in the above figure for the bottom half. In this region non-bonding is not acceptable.</p> <p>The <b>TEST ZONE 2</b> covers entire top half and the single hatched areas of the bottom half. Each indication area has to be assessed individually in view of the percentage of the defect area and of edge zone and/or edge lengths.</p>		
<b>COPYRIGHT AND CONFIDENTIAL</b> This is a confidential document and its contents are not to be disclosed to anyone without the written permission of the concerned authority.	<p>In this zone:</p> <ul style="list-style-type: none"> <li>- The total area with non bonding must not exceed 5% of each individual test range.</li> <li>- Individual non bond areas of size upto <math>A=4 \times b</math> are permissible, provided two isolated non bond areas are separated by at least 10mm from each other, otherwise they are to be treated as a single defect.</li> <li>- The width/length ratio of the non bonding area confirms to <math>e/c \geq 1/4</math> where e &amp; c are explained in the sketch above.</li> <li>- At edge zone, max 4 % defect length related to the single edge length but not exceeding 20 mm is permissible.</li> </ul> <p><b>Note:</b></p> <ul style="list-style-type: none"> <li>- The edge zone is the visible transition from the backing to the backing material</li> <li>- In case of journal bearing, the edge length is the edge zone of the joint face (b in fig 9)</li> <li>- In case of thrust bearing, the edge length is the edge zone of plane face (b in Fig 10)</li> </ul>		
अनुमोदित एवं प्रमाणित अनुमोदित एवं प्रमाणित करने वाले का नाम अनुमोदित एवं प्रमाणित करने की तिथि	<div style="display: flex; justify-content: space-around;"> <div data-bbox="422 1131 710 1400">  <p style="text-align: center;">Fig 9</p> </div> <div data-bbox="853 1153 1157 1422">  <p style="text-align: center;">Fig.10</p> </div> </div>		
अनुमोदित एवं प्रमाणित करने वाले का नाम अनुमोदित एवं प्रमाणित करने की तिथि			
अनुमोदित एवं प्रमाणित करने वाले का नाम अनुमोदित एवं प्रमाणित करने की तिथि	REV. NO. 02		विकसित WORKED BY Sh Kamal Singh Kamal Singh जांचा CHECKED BY Sh Vinod Kumar Vinod Kumar DUM MAL

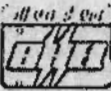
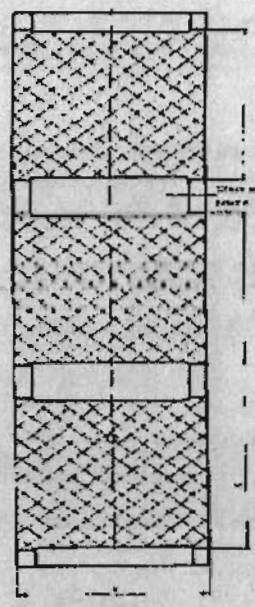
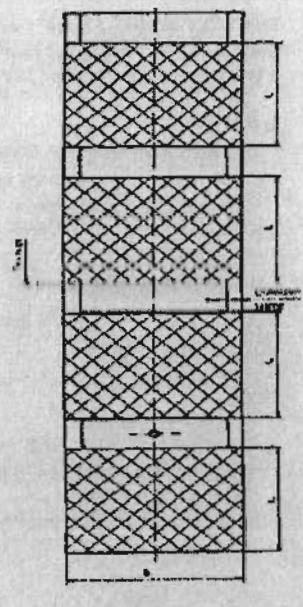
Date of issue दिनांक जारी		संस्थान मानक (डीप - हरिद्वार) <b>PLANT STANDARD (HEEP - HARDWAR)</b>	<b>HW 0850195</b> पृष्ठ का Page 10 of 11
Inventory No INVENTORY NO	<b>Annexure- II</b>		
Rev. No संशोधन क्र.	<b>Three &amp; Four Stage Bearings</b>		
In these bearings the test area shall consist of cross hatched areas as shown below. Non bond areas are not allowed in these bearings.			
			
3 stage bearing $L = \frac{D \times \pi \times 100^\circ}{360^\circ} \text{ (mm)}$	4 stage bearing $L = \frac{D \times \pi \times 70^\circ}{360^\circ} \text{ (mm)}$		
<b>Fig. 11</b>	<b>Fig. 12</b>		
Copyright and Confidential The information in this document is the property of HEEP - HARDWAR. It is to be used only for the purpose intended and is not to be disclosed to any other person without the written consent of the company.	स्वतन्त्रिकर एवं गोपनीय इस दस्तावेज में दी गई जानकारी HEEP - HARDWAR की संपत्ति है। इसे केवल उद्देश्य के लिए ही प्रयोग किया जाना है। इसे किसी भी अन्य व्यक्ति को बिना लिखित अनुमति के नहीं देना है।		
Date दिनांक	08/11/2018		
Inventory No INVENTORY NO	REV. NO.	Prepared तैयार किया	Sh Kamal Sehgal Kamal Sehgal
P-3041	02	Checked by जांचा	Sh Vivek Mittal Vivek Mittal Dgm mpl

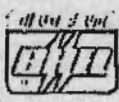
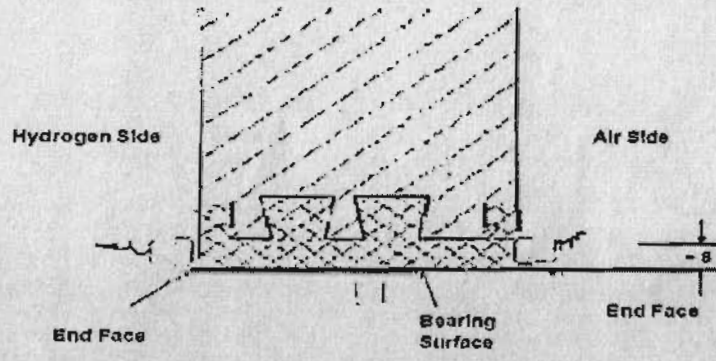
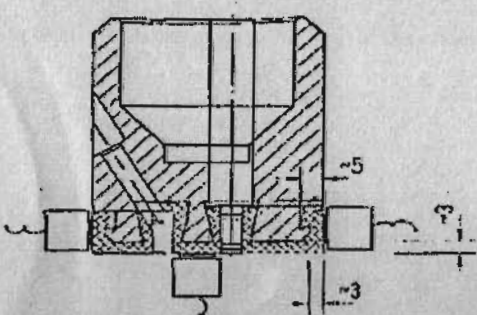
	<b>संस्थान मानक (हीप - हरिद्वार)</b> <b>PLANT STANDARD (HEEP - HARDWAR)</b>	<b>HW 0850195</b> पृष्ठ का Page 11 of 11
Name of Project Date Design No. Revision No.	<b>Annexure- III</b> <b>Sealing Rings</b> The ultrasonic testing shall be done on end faces and bearing surfaces as shown in figure 13 and 14.	
Copyright and Confidential This document is the property of the organization and its contents shall not be disclosed to any other person without the written permission of the organization.		
सहायिका एवं गोपनीय This document is the property of the organization and its contents shall not be disclosed to any other person without the written permission of the organization.		
Design No. Date Design No. Revision No.	<b>Fig. 13. Ultrasonic testing after rough machining.</b> <b>Fig. 14. Ultrasonic testing after final machining.</b>	
<b>Acceptance norms for sealing rings</b> A maximum of 4 recordable indications, with a total recording length of 50 mm on each end face and bearing surface. Maximum allowable length of individual indication is 15 mm. The distance to adjacent indications shall be at least twice the defect length of the larger indication. Otherwise, the indication free space between the indications must be added to total indication length, in addition to the individual indication length.		
Design No. Date Design No. Revision No.	REV. NO. 02	Prepared by Sh Kamal Sehgal Kamal Sehgal Checked by Sh Vivek Mittal Vivek Mittal Dhm mal

**GENERAL COMMERCIAL TERMS & CONDITIONS OF ENQUIRY FOR CAPITAL ITEM PURCHASE  
(FOR INDIAN AS WELL AS FOREIGN VENDORS)**

ANNEXURE-Z

ITEM DESCRIPTION:  
ENQUIRY NO: E-588-23-0010-69-1

Sl No	BHEL STANDARD TERMS & CONDITIONS	CONFIRMATION OF SUPPLIER YES / NO
1	<p>OFFER IN TWO PART BID SYSTEM MAY BE SUBMITTED IN ANY OF THE FOLLOWING MODES ONLY AS MENTIONED BELOW.</p> <p><b>FIRST MODE</b>- ON EMAIL ID – <a href="mailto:TENDERHERP@BHEL.IN">TENDERHERP@BHEL.IN</a> <b>SECOND MODE</b>- THROUGH COURIER IN HARD COPY</p> <p>OFFERS SUBMITTED THROUGH ANY OTHER MODE THAN SPECIFIED ABOVE WILL BE REJECTED OUTRIGHTLY.</p>	
1.1	<p><b>FIRST MODE- OFFERS THROUGH EMAIL</b></p> <p>THE OFFER IS TO BE SUBMITTED IN TWO PARTS. TECHNICAL BID &amp; PRICE BID TO BE SUBMITTED SEPARATELY TO MAIL ID <a href="mailto:tenderherp@bhel.in">tenderherp@bhel.in</a> AS AN ATTACHMENT ONLY. INTERCHANGING THE INFORMATION IN THE MAILS MAY LEAD TO REJECTION OF THE OFFER. SUPPLIER SHALL HAVE NO CLAIM ON EMAIL OFFERS SENT ON ANY OTHER E-MAIL ID. COPY (CC/BCC) OF MAIL IS NOT BE MARKED TO ANY OTHER BHEL OFFICIAL MAIL.ID.</p> <p>IN CASE OF E-MAIL OFFERS, THE MAIL SUBJECT SHOULD CONTAIN BID TYPE (TECHNICAL BID (PART-1) OR PRICE BID (PART-2)), ENQUIRY NO. DUE DATE AND SUPPLIER NAME, SUPPLIER ADDRESS INCLUDING CONTACT DETAILS SHALL BE MENTIONED IN THE CONTENT OF THE MAIL. WITHOUT THESE DETAILS OFFER IS LIABLE FOR REJECTION.</p> <p>THE SIZE OF THE ATTACHEMENT IN MAIL SHOULD NOT BE MORE THAN 15 MB. IF THE ATTACHEMENTS ARE MORE THAN 15 MB, EITHER OPTIMIZE THE SIZE OF ATTACHMENT OR ATTACHEMENTS CAN BE SENT THROUGH SEPARATE MAIL. IT IS BIDDER'S RESPONSIBILITY TO ENSURE THAT THE EMAIL OFFERS SHOULD REACH TO <a href="mailto:TENDERHERP@BHEL.IN">TENDERHERP@BHEL.IN</a> UPTO SCHEDULED TENDER OPENING DATE AND TIME .</p>	
1.2	<p><b>SECOND MODE- OFFERS THROUGH COURIER IN HARD COPY</b></p> <p>A) OFFER MUST BE SUBMITTED IN TWO PART BID SYSTEM NAMELY TECHNO-COMMERCIAL BID &amp; PRICE BID FOR THE ITEM AS PER ENQUIRY IN SEPARATE SEALED COVERS: (I) TECHNO – COMMERCIAL BID &amp; (II) PRICE BID SHOULD BE CLEARLY SUPERSCRIBED THE ENQUIRY NO. AND DUE DATE ON THE ENVELOPES. (B) UN-PRICED OFFER WITH TECHNICAL BID IS REQUIRED TO BE FURNISHED BY THE VENDOR. TECHNICAL OFFER SHOULD CLEARLY REFLECT AT LEAST OUR MATERIAL CODE, ITEM DESCRIPTION &amp; QUANTITY. (C) THE DIFFERENCE BETWEEN “UN-PRICED OFFER” AND “PRICED OFFER” SHOULD BE ONLY THE PRICES WHEREVER APPLICABLE. THE RATES AND AMOUNT SHOULD BE CLEARLY WRITTEN IN FIGURES AND WORDS BOTH WITHOUT ANY CUTTING / OVERWRITING. (D) <b>IMPORTANT POINT FOR VENDOR WHO HAVE NOT SUBMITTED THE SRF (SUPPLIER REGISTRATION FORM) SO FAR:</b> THE VENDORS, WHO HAVE NOT SUBMITTED THE SRF SO FAR, MUST SUBMIT THE SAME ALONG WITH PART- 1 BID. THE SRF TO BE DOWNLOADED FROM WWW.BHEL.COM OR <a href="https://herp.bhel.com">https://herp.bhel.com</a> .</p>	
2	<p>PART-I CONTAINING THE TECHNO-COMMERCIAL BID WILL BE OPENED ON THE DATE AND TIME SPECIFIED IN THE ENQUIRY, IN THE PRESENCE OF THOSE TENDERERS WHO WISH TO ATTEND. PART-II i.e., PRICE BID WILL BE OPENED ONLY OF THOSE BIDDERS WHO ARE FOUND TECHNO-COMMERCIALY SUITABLE AFTER SCRUTINY OF THEIR PART-I OFFERS.</p>	
3	<p>NO REVISED OFFERS WILL BE ACCEPTED UNLESS ASKED BY BHEL AFTER OPENING OF PART-1 BID IN ANY CASE.</p>	
4	<p>TENDER OPENING IS SCHEDULED TO START IN THE TENDER ROOM AT 2:00 PM, ON THE DUE DATE. THEREFORE, BID / QUOTATIONS MUST REACH THIS OFFICE / TENDER BOX LATEST BY 1:45 PM ON DUE DATE. ONLY PARTICIPATING BIDDERS ARE ALLOWED TO ATTEND TENDER OPENING. <b>TENDERS RECEIVED AFTER THE SPECIFIED TIME OF THEIR 'SUBMISSION' WILL BE TREATED AS LATE TENDERS AND SHALL NOT BE CONSIDERED UNDER ANY CIRCUMSTANCES.</b> THE BIDDERS OR THEIR AUTHORIZED REPRESENTATIVES MAY BE ALLOWED TO ATTEND TENDER OPENING IF DULY AUTHORIZED BY THEIR PRINCIPALS, THROUGH A TENDER SPECIFIC LETTER ON THAT PARTICULAR DAY. GENERAL AUTHORIZATION LETTER IS NOT ACCEPTABLE. NOTE: - FOREIGN BIDDERS WILLING TO ATTEND THE BID OPENING HAS TO PROVIDE THE REQUISITE DOCUMENTS TO THE CONCERNED PURCHASE EXECUTIVES FOR ARRANGING GATE PASS FOR THEM.</p>	
5	<p>YOUR TECHNO COMMERCIAL BID SHOULD MENTION THAT PRICE BID HAS BEEN SENT IN A SEPARATE ENVELOPE GIVING ITS REFERENCE.</p>	
6	<p>BID SHOULD BE FREE FROM CORRECTION, OVERWRITING, USING CORRECTIVE FLUID, ETC. ANY INTERLINEATION, CUTTING , ERASURE OR OVERWRITING SHALL BE VALID ONLY IF THEY ARE ATTESTED UNDER FULL SIGNATURE(S) OF PERSON(S) SIGNING THE BID ELSE BID SHALL BE LIABLE FOR REJECTION .</p> <p>VALIDITY: SUPPLIER TO MENTION CLEARLY THE VALIDITY OF THE OFFER MINIMUM 120 DAYS FROM TENDER OPENING DATE.</p>	
7	<p>IN CASE OF FOREIGN BIDDER, FORMAT FOR LANDED COST CALCULATION IS ATTACHED HERewith. THIS FORMAT INCLUDES CUSTOMER DUTY CHARGES, INLAND TRANSPORTATION CHARGES, ANT OTHER TAXES AND DUTIES, ANY OTHER CHARGES. SAME ANNEXURE (CALCULATION GIVEN IN TRAIL FOR INDIAN BIDDER) IS APPLICABLE FOR INDIAN BIDDERS FOR LANDED COST CALCULATION.</p> <p>LODGING &amp; BOARDING CHARGES, LOCAL CONVEYANCE, AIR &amp; INLAND FARE, ANY OTHER CHARGES TOWARDS ERECTION &amp; COMMISSIONING HAS TO BE BORNE BY SUPPLIER / VENDOR ONLY. VENDOR SHOULD QUOTE THEIR RATE BY CONSIDERING ALL THE CHARGES.</p>	
8	<p>PRICING TERMS: PRICES ONCE QUOTED SHALL REMAIN FIRM WITHIN THE VALIDITY OR ANY EXTENSION THEREOF FOR PLACEMENT OF ORDER, TILL COMPLETE EXECUTION OF THE ORDER, WITHOUT ANY ESCALATION/INCREASE FOR ANY REASON, WHATSOEVER, UNLESS SPECIFICALLY PROVIDED FOR IN THE ENQUIRY &amp; PO.</p> <p>PURCHASE ORDERS MAY BE RELEASED SEPARATELY FOR SUPPLY AND SERVICE PORTION ON THE SUCCESSFUL VENDOR.</p>	
9	<p>UNLESS SPECIFIED IN THE TENDER, VENDOR MUST NOTE THAT BHEL WILL ARRIVE THE L1 STATUS FOR EACH ITEM ON LANDED COST BASIS. ACCORDINGLY, ORDER SHALL BE PLACED ON LOWEST BIDDER ON INDIVIDUAL ITEM BASIS ONLY, UNLESS BHEL ASK FOR TERMS OTHER THAN THIS ON EXCEPTION BASIS. IN THE COURSE OF EVALUATION, IF MORE THAN ONE BIDDER HAPPENS TO OCCUPY L-1 STATUS, EFFECTIVE L-1 WILL BE DECIDED BY SOLICITING DISCOUNTS FROM THE RESPECTIVE L-1 BIDDERS. IN CASE MORE THAN ONE BIDDERS HAPPENS TO OCCUPY THE L-1 STATUS EVEN AFTER SOLICITING DISCOUNT, THE L-1 BIDDER SHALL BE DECIDED BY A TOSS/DRAW OF LOTS, IN THE PRESENCE OF THE RESPECTIVE BIDDER(S) OR THEIR REPRESENTATIVE(S). RANKING WILL BE DONE ACCORDINGLY. BHEL'S DECISION IN SUCH SITUATION SHALL BE FINAL AND BINDING.</p>	
10	<p>PLEASE MAKE SURE THAT THERE IS NO DISCREPANCY IN BETWEEN ACCEPTED TERMS &amp; CONDITIONS MENTIONED IN THE CHECK LIST AND QUOTATION SUBMITTED BY VENDOR AND IF FOUND SO THEN THE TERMS &amp; CONDITIONS WHICH ARE BENEFICIAL TO BHEL WOULD ONLY BE CONSIDERED.</p>	
11	<p>VENDOR TO ENSURE THAT ITEM &amp; QUANTITY MENTIONED IN THE OFFERS ARE EXACTLY SAME AS PER ENQUIRY. IF ANY DEVIATION IS THERE PARTY MUST MENTION SPECIFIC HERewith OTHERWISE BHEL SHALL CONSIDER THAT ITEM &amp; QUANTITY AS REQUIRED IN ENQUIRY.</p>	
12	<p>BHEL RESERVES THE RIGHT TO REJECT THE OFFER, WHICH IS HAVING DEVIATIONS TO THE TERMS AND CONDITIONS GIVEN IN THE TENDER ENQUIRY.</p>	
13	<p>GST IF APPLICABLE WILL BE PAID EXTRA AGAINST DOCUMENTARY PROOF. THE RATE OF GST SHOULD BE CLEARLY MENTIONED IN THE OFFER.</p>	

**GENERAL COMMERCIAL TERMS & CONDITIONS OF ENQUIRY FOR CAPITAL ITEM PURCHASE  
(FOR INDIAN AS WELL AS FOREIGN VENDORS)**

ANNEXURE-Z

14	<p><b>TERMS OF DELIVERY:</b></p> <p><b>I. FOR INDIGENOUS SUPPLIERS:</b> THE TERMS OF DELIVERY SHOULD BE QUOTED ON F.O.R. DESTINATION (BHEL HERP STORES VARANASI) BASIS ONLY (i.e. FREIGHT &amp; INSURANCE ON VENDOR'S ACCOUNT ONLY). IF ANY BIDDER STILL QUOTES OTHER DELIVERY TERM IN PLACE OF BHEL HERP STORES, THEIR OFFER MAY NOT BE CONSIDERED FOR FURTHER PROCESSING. IT MUST BE SPECIFICALLY NOTED.</p> <p><b>II. FOR FOREIGN SUPPLIER:</b> TERMS OF DELIVERY SHOULD BE QUOTED ON CIF JNPT, NHAVA SHEVA, INDIA SEA PORT BASIS (i.e. FREIGHT &amp; INSURANCE ON VENDOR'S ACCOUNT UPTO JNPT, NHAVA SHEVA, INDIA SEA PORT) OR CFR MUMBAI AIRPORT. HOWEVER FREIGHT CHARGES (2% OF FOB IN INR OR AS PER BHEL TRANSPORT RATE CONTRACT WHICHEVER IS HIGHER) FROM MUMBAI TO BHEL VARANASI WILL BE LOADED AT THE TIME OF TOTAL LANDED COST CALCULATION FOR EACH ITEM.</p>	
15	<p>IF ANY INDIAN SUPPLIERS ARRANGE SUPPLY FROM FOREIGN PRINCIPLES/WORKS, TERMS OF DELIVERY SHOULD BE QUOTED ON CIF JNPT, NHAVA SHEVA, INDIA SEA PORT BASIS ONLY (i.e. FREIGHT &amp; INSURANCE ON VENDOR'S ACCOUNT UPTO JNPT, NHAVA SHEVA, INDIA SEA PORT) OR CFR MUMBAI AIRPORT. HOWEVER, FREIGHT CHARGES AS PER BHEL TRANSPORT CONTRACT FROM JNPT, NHAVA SHEVA, INDIA SEAPORT/MUMBAI AIRPORT TO BHEL VARANASI FOR EACH ITEM WILL BE LOADED AT THE TIME OF TOTAL LANDED COST CALCULATION.</p> <p>INDIAN CUSTOMS IS IMPOSING A PENALTY ON LATE FILING OF BILL OF ENTRIES (AIR/SEA SHIPMENTS) BY THE IMPORTER. THE MAXIMUM FREE TIME ALLOWED IS 24 HRS FROM THE TIME OF ARRIVAL OF CARGO AT FINAL PORT OF DISCHARGE. RS.5000/- PER DAY (FOR INITIAL 03 DAYS) &amp; RS.10000/- PER DAY (THEREAFTER)</p> <p>1) THE VENDOR SHOULD FURNISH THE NON-NEGOTIABLE DOCUMENTS (AIR WAY BILL/BILL OF LADING, COMMERCIAL INVOICE, PACKING LIST, CERTIFICATE OF ORIGIN, PORT OF LOADING, NAME OF VESSEL, PURCHASE ORDER NO AND DATE) EITHER BY EMAIL OR POST/COURIER TO BHEL WELL BEFORE THE LANDING OF CARGO AT FINAL PORT OF DISCHARGE.</p> <p>2) VENDOR WILL BE HELD RESPONSIBLE FOR THE PENALTY ARISES AGAINST THE LATE FILING OF BILL OF ENTRY DUE TO: A. NON AVAILABILITY OF NON-NEGOTIABLE DOCUMENTS (NNDS) BEFORE THE CARGO ARRIVAL B. DISCREPANCY IN DOCUMENTS C. SHORT LANDING OF CONSIGNMENTS (FOR SHIPMENTS ON CFR/CPT/CIF/CIP – JNPT, NHAVA SHEVA, INDIA PORT)</p>	
16	<p>INSURANCE CHARGES SHALL BE TO VENDOR'S ACCOUNT ONLY IF PRICE QUOTED ON BHEL HERP STORES BASIS. IN CASE PRICE QUOTED IS ON CIF JNPT, NHAVA SHEVA, INDIA BASIS/ CFR MUMBAI AIRPORT BASIS, INSURANCE UP TO CIF JNPT, NHAVA SHEVA, INDIA SEA PORT / MUMBAI AIRPORT SHALL BE IN VENDOR ACCOUNT.</p>	
17	<p><b>TERMS OF PAYMENT FOR INDIGENOUS OFFER:(SUPPLY AND E&amp;C TO BE DONE BY VENDOR)</b></p> <p>PAYMENT TERMS :80 % OF SUPPLY VALUE SHALL BE PAID AGAINST SRV AS PER NIT T&amp;C FROM THE DATE OF RECEIPT OF MATERIAL AT BHEL. BALANCE 20% OF SUPPLY AND 100% OF E&amp;C PORTION OF PO VALUE SHALL BE PAID ON ISSUE OF INSTALLATION CERTIFICATE. PAYMENT OF INSTALLATION VALUE SHALL BE MADE AGAINST INSTALLATION CERTIFICATE ISSUED BY BHEL. INSTALLATION CERTIFICATE SHALL BE ISSUED ON SATISFACTORY COMPLETION OF ERECTION, COMMISSIONING, JOB PROVING, PERFORMANCE TESTS, TRAINING TO OPERATORS ETC. AS ENVISAGED IN PO AND SUBMISSION OF PBG (PERFORMANCE BANK GUARANTEE).</p> <p>PAYMENT AS ABOVE WILL BE MADE AS PER BELOW CATEGORIES: -</p> <p>I. FOR MSEs VENDORS: 80% PAYMENT WITHIN 45 DAYS OF SRV AND SUBMISSION OF BILL. II. FOR NON-MSEs SUPPLIERS: 80% PAYMENT WITHIN 90 DAYS OF SRV AND SUBMISSION OF BILL.</p> <p><b>BHEL HERP WILL MAKE PAYMENTS IN TWO PARTS: -</b> <b>PART-I:</b> BASIC INVOICE VALUE AND ALL OTHER CHARGES (EXCEPT GST AMOUNT) WILL BE PAID AS PER P.O. PAYMENT TERMS. <b>PART-II:</b> GST PORTION OF INVOICE VALUE WILL BE PAID ONLY AFTER FULFILLING FOLLOWING CONDITIONS: (A) PAYMENT OF GST AMOUNT INTO GOVT.ACCOUNT BY SUPPLIER AGAINST INVOICE RAISED TO BHEL. (B) FILING OF GST RETURN WITHIN SCHEDULED DATE. (C) DISPLAY OF GST CREDIT AGAINST BHEL GSTIN NO.09AAACB4146P22C ON GSTN PORTAL.</p> <p>NOTE: ADVANCE PAYMENT IS NOT ACCEPTABLE BY BHEL HERP VARANASI IN ANY CASE. UNDER ALL CIRCUMSTANCES, CEBG SHALL BE KEPT VALID, TILL THE PBG BECOMES OPERATIONAL.</p> <p><b>TERMS OF PAYMENT FOR FOREIGN OFFERS:( SUPPLY AND E&amp;C TO BE DONE BY VENDOR)</b></p> <p>(I) TOTAL SUPPLIES ARE TO BE FROM FOREIGN SOURCE. WHERE THE PAYMENTS ARE THROUGH L.C (L.C OPENING CHARGES ARE TO BE LOADED) PAYMENT OF SUPPLY VALUE SHALL BE 80% ON DISPATCH AND BALANCE 20% OF SUPPLY VALUE AND 100% OF E&amp;C PORTION OF PO VALUE SHALL BE PAID ON ISSUE OF INSTALLATION CERTIFICATE. PAYMENT OF INSTALLATION VALUE SHALL BE MADE AGAINST INSTALLATION CERTIFICATE ISSUED BY BHEL. INSTALLATION CERTIFICATE SHALL BE ISSUED ON SATISFACTORY COMPLETION OF ERECTION, COMMISSIONING, JOB PROVING, PERFORMANCE TESTS, TRAINING TO OPERATORS ETC. AS ENVISAGED IN PO AND SUBMISSION OF PBG (PERFORMANCE BANK GUARANTEE. THE L.C. SHALL BE OPENED BY BHEL AS PER THE FOLLOWING.</p> <p>WITHIN 30 DAYS OF RECEIPT OF ACCEPTABLE CEBG, AN IRREVOCABLE UNCONFIRMED <b>USANCE L/C WITH 120 DAYS CREDIT</b> WILL BE OPENED FOR 30% OF THE PAYMENT TOWARDS SUPPLY, DUE ON SHIPMENT I.E. 24% OF THE SUPPLY VALUE OF THE P.O. (30% OF 80%). NOT EARLIER THAN 60 DAYS BEFORE THE SHIPMENT DATE, THE VALUE OF THIS IRREVOCABLE UNCONFIRMED L/C WOULD BE ENHANCED FROM 24% TO 80% OF THE SUPPLY VALUE OF THE P.O. THE ABOVE L/C CAN BE NEGOTIATED AFTER THE SHIPMENT AGAINST SUBMISSION OF B/L OR AWB, AND SUCH OTHER DOCUMENTS, AS MENTIONED IN THE P.O. OR L/C AND SUBMISSION OF PRE DISPATCH INSPECTION REPORT OF BHEL. THIS L/C WILL BE VALID FOR A PERIOD EXTENDING 21 DAYS BEYOND THE SHIPMENT DATE FOR NEGOTIATION OF DOCUMENTS.</p> <p>(II) WHENEVER THERE IS AN INDIAN AGENT TO REPRESENT A SUPPLIER, IT IS ESSENTIAL TO GIVE THE DETAILS OF SERVICES TO BE RENDERED BY INDIAN AGENT AND / OR THE DETAILS OF AGREEMENT BETWEEN SUPPLIER AND AGENT. INDIAN AGENT COMMISSION SHOULD BE INCLUDED IN THE PRICE QUOTED BY THE PARTY. IF NOT, SUPPLIER TO INDICATE THE AGENCY COMMISSION PAYABLE, THEN INDIAN AGENCY COMMISSION WILL BE PAID ONLY IN INDIAN RUPEES, CALCULATED AT THE RATE OF EXCHANGE PREVAILING ON THE DATE OF THE TENDER OPENING. THIS IS PAYABLE ON SATISFACTORY COMPLETION OF THE CONTRACT. THIS COST WILL BE LOADED WHILE ARRIVING AT LANDED COST CALCULATION.</p> <p>NOTE: IN ORDER TO MAINTAIN SANCTITY OF THE TENDER SYSTEM, IT IS ESSENTIAL THAT ONE AGENT CANNOT REPRESENT TWO SUPPLIERS OR QUOTE ON THEIR BEHALF IN A PARTICULAR TENDER ENQUIRY. IF ANY AGENT REPRESENTS MORE THAN ONE SUPPLIERS, ALL THE OFFERS ASSOCIATED WITH THE AGENT WILL BE REJECTED.TAX DEDUCTION AT SOURCE IS APPLICABLE TO THE AGENCY COMMISSION PAID TO THE INDIAN AGENT AS PER PREVAILING RATE.</p> <p>(III) THE SECOND IRREVOCABLE &amp; UNCONFIRMED LETTER OF CREDIT FOR 20% OF SUPPLY PORTION AND &amp; 100% OF E&amp;C CHARGES WILL BE OPENED 15 DAYS PRIOR TO THE SCHEDULED AND CONFIRMED ARRIVAL OF THE TECHNICIANS OF SUPPLIER WITH THEIR NAMES THE VALIDITY OF THIS L/C WOULD BE SUFFICIENT TO COVER THE PERIOD REQUIRED FOR THE COMPLETION OF INSTALLATION + 21 DAYS AS NEGOTIATION PERIOD. THIS L.C CAN BE NEGOTIATED I) AFTER COMPLETION OF THE INSTALLATION OF THE EQUIPMENT IN BHEL. THIS IS SUBJECT TO THE SUBMISSION OF PERFORMANCE BANK GUARANTEE FOR 10% OF CONTRACT VALUE VALID FOR 60 DAYS BEYOND THE GUARANTEE / WARRANTY PERIOD OF 24 MONTHS FROM THE DATE OF COMMISSIONING. THE BANK GUARANTEE IS TO BE ATTESTED BY INDIAN EMBASSY &amp; TO BE REGISTERED IN INDIA. PBG CONFIRMATION CHARGES SHALL BE BORNE BY VENDOR.</p> <p>NOTE- UNDER ALL CIRCUMSTANCES, CEBG SHALL BE KEPT VALID, TILL THE PBG BECOMES OPERATIONAL.</p>	

**GENERAL COMMERCIAL TERMS & CONDITIONS OF ENQUIRY FOR CAPITAL ITEM PURCHASE  
(FOR INDIAN AS WELL AS FOREIGN VENDORS)**

ANNEXURE-Z

18	<p><b>LOADING OF PAYMENT TERM:</b></p> <p>IF PAYMENT TERMS AS MENTIONED BY BHEL ARE NOT AGREED BY BIDDER, SUCH BIDDER HAVE TO SUBMIT BANK GUARANTEE AT THE TIME OF PAYMENT / OPENING OF LC IN THE PRECISBED FORMAT OF THE AMOUNT, EXCEEDING 80% OF THE PO VALUE, VALID TILL ISSUE OF E&amp;C CERTIFICATE FOR THE EQUIPMENT. HOWEVER, IN NO CASE, PAYMENT AGAINST DISPATCH SHALL EXCEED 90% OF THE PO VALUE.</p> <p><b>ADDITIONALLY, FOR ANY DEVIATION SOUGHT INCLUDING AS MENTIONED ABOVE, IN PAYMENT TERM BY BIDDER W.R.T. TENDER CONDITIONS, FOLLOWING LOADING SHALL BE FOLLOWED:-</b></p> <p>IN CASE OF DEVIATION, LOADING OF INTEREST RATE @SBI MCLR RATE + 6% (AS ON PART-1 OPENING DATE) SHALL BE LOADED WHILE ARRIVING AT LANDED COST TO BHEL TO THE EXTENT TO WHICH IT IS NOT AGREED BY THE BIDDER.</p> <p><b>ADDITIONAL TERMS:-</b></p> <ol style="list-style-type: none"> <li>I. SUPPLIER SHALL BEAR THE L/C CONFIRMATION CHARGES IN CASE OF CONFIRMED L/C AMENDED ON HIS REQUEST.</li> <li>II. BANK CHARGES OUT SIDE INDIA ARE TO THE SUPPLIER'S ACCOUNT.</li> <li>III. IN CASE OF L/C EXTENSION CAUSED BY DELAYS, ATTRIBUTABLE TO THE SUPPLIER, THE L/C EXTENSION CHARGES ARE TO BE BORNE BY THE SUPPLIER.</li> <li>IV. ANY FREE REPLACEMENT DUE TO SHORT SUPPLY OR WARRANTY REPLACEMENT WILL ATTRACT CUSTOMS DUTY ETC. ALL SUCH EXTRA EXPENDITURE TO BHEL WILL BE RECOVERED FROM SUPPLIER. OTHERWISE THE SAME WILL BE RECOVERED FROM 20% BALANCE PAYMENT, FROM AGENCY COMMISSION, ETC.</li> </ol>	
19	<p><b>VALUE FOR ERECTION &amp; COMMISSIONING AT BHEL:</b></p> <p>ERECTION &amp; COMMISSIONING (E&amp;C) VALUE WILL INCLUDE SERVICES TO BE RENDERED AT BHEL LIKE ERECTION, COMMISSIONING, JOB PROVING, PERFORMANCE TESTS, AND TRAINING TO OPERATORS ETC.</p> <p><b>THE ESTIMATED PERCENTAGE OF E&amp;C VALUE SHALL BE MORE THAN OR EQUAL TO 7.5%.</b></p> <p>E&amp;C VALUE SHOULD BE QUOTED SEPARATELY BY BIDDERS. ONLY IN CASE WHERE QUOTED VALUE IS LESS THAN THE VALUE (IN %) SPECIFIED IN THE NIT OR SEPARATE E&amp;C VALUES ARE NOT MENTIONED IN THE OFFER, VALUE FOR E&amp;C PORTION SHALL BE DEEMED TO BE CONSIDERED AS THE VALUE INDICATED IN NIT &amp; ACCORDINGLY SUPPLY VALUE WILL BE ADJUSTED FROM THAT QUOTED VALUE AND BALANCE WILL BE RELEASED AS E&amp;C PAYMENT AS PER CLAUSE 17.</p>	
20	<p><b>CONTRACT EXECUTION BANK GUARANTEE (CEBG):-</b></p> <p>THE CEBG SHALL BE FOR THE DUE AND FAITHFUL PERFORMANCE OF THE CONTRACT AND SHALL REMAIN BINDING NOT WITHSTANDING SUCH VARIATIONS, ALTERNATIONS OR EXTENSIONS OF TIME AS MAY BE MADE, GIVEN, CONCEDED OR AGREED TO BETWEEN THE SUPPLIER / VENDOR AND BHEL UNDER THESE TERMS &amp; CONDITIONS OR OTHERWISE.</p> <p>THE CEBG FURNISHED BY THE TENDERER WILL BE SUBJECT TO THE TERMS AND CONDITIONS OF THE CONTRACT FINALLY CONCLUDED BETWEEN THE PARTIES AND THE BHEL WILL NOT BE LIABLE FOR PAYMENT OF ANY INTEREST ON THECEBG OR ANY DEPRECIATION THEREOF</p> <p>THE SUCCESSFUL VENDOR SHALL HAVE TO FURNISH A CONTRACT EXECUTION BANK GUARANTEE(CEBG) FOR 10% (TEN PERCENT) OF THE TOTAL PO VALUE IN THE PRESCRIBED FORMAT WITHIN 30 DAYS FROM THE DATE OF PO BUT BEFORE LC OPENING. CEBG SHALL BE FROM THE ONE OF THE CONSORTIUM BANKS OF BHEL OR FROM A REPUTED BANK AND CONFIRMED BY ANY CONSORTIUM BANKS OF BHEL. ALL BANK CHARGES ON ACCOUNT OF ISSUANCE AND CONFIRMATION OF CEBG WHETHER INCURRED IN INDIA OR OUTSIDE INDIA WILL HAVE TO BE BORNE BY THE VENDOR.</p> <p>CEBG SHALL BE KEPT VALID UNTIL 30 DAYS AFTER THE DATE OF INSTALLATION CERTIFICATE, WHICH WILL BE ISSUED ON COMPLETION OF INSTALLATION OF EQUIPMENT WHICH INCLUDES ERECTION, COMMISSIONING, JOB PROVING, PERFORMANCE TESTS, TRAINING TO OPERATORS ETC. AS PRESCRIBED IN PO. UNDER ALL CIRCUMSTANCES, CEBG SHALL BE KEPT VALID, TILL THE PBG BECOMES OPERATIONAL.</p> <p>IF THE SUPPLIER FAILS TO SUBMIT THE CEBG EVEN WITHIN 60 DAYS FROM THE DATE OF PO, BHEL RESERVES THE RIGHT TO CANCEL THE PO AND FORFEIT EMD GIVEN BY THE SUPPLIER. IN ADDITION, IN SUCH CASE, ACTION WILL BE INITIATED IN LINE WITH EXTANT GUIDELINES FOR SUSPENSION OF BUSINESS DEALINGS WITH SUPPLIERS.</p> <p>NOTE: IN CASE OF NON SUBMISSION OF CEBG WITHIN TWO MONTHS, BHEL SHALL CHARGE @ 1.5% PER MONTH ON THE CEBG AMOUNT FOR THE DELAYED PERIOD PORTION BEYOND 2 MONTHS AND DEDUCT THE SAME IN THE FINAL BILL.</p> <p>THE CEBG SHOULD BE FURNISHED AS PER PROFORMA ENCLOSED IN ANNEXURE-BG. THE CEBG SHALL BE IN THE CURRENCY OF THE PURCHASE ORDER. THE CEBG SHALL BE REFUNDED / BANK GUARANTEE RELEASED ON APPLICATION BY VENDOR /CONTRACTOR AFTER COMMISSIONING OF THE EQUIPMENT AND AFTER IT HAS DISCHARGED ALL HIS OBLIGATIONS UNDER THE CONTRACT AND PRODUCED A CERTIFICATE FROM BHEL, CERTIFYING DUE COMPLETION OF THE WORK AND SUBMITTED A 'NO DEMAND CERTIFICATE'.</p>	
21	<p>THE VENDOR SHALL ENSURE THAT THEIR BANK DETAILS ARE UPDATED WITH US FOR TIMELY PAYMENT THROUGH EFT (ELECTRONICS FUND TRANSFER).</p>	
22	<p><b>EARNEST MONEY DEPOSIT:</b></p> <p>EMD of Rs 200000/- (TWO LAKHS ONLY) TO BE SUBMITTED FOR THIS TENDER ENQUIRY.</p> <p>MSEs &amp; CENTRAL/STATE PSE SHALL BE EXEMPTED FROM PAYMENT OF EARNEST MONEY COST AT THE TIME OF TENDER DEPOSIT. HOWEVER, THERE IS NO EXEMPTION OF SECURITY DEPOSIT SUBMISSION. NO BENEFITS SHALL BE APPLICABLE FOR THAT PARTICULAR ENQUIRY IF THE REQUIRED DOCUMENTS ARE NOT SUBMITTED BEFORE PRICE BID OPENING.</p> <p>UNLESS SPECIFICALLY STATED OTHERWISE, BIDDER SHALL HAVE TO DEPOSIT ANY/ALL PAYMENTS THROUGH EFT IN FAVOUR OF BHARAT HEAVY ELECTRICALS LTD. COPY OF THE UTR RECEIPT FOR EACH PAYMENT SHALL BE ENCLOSED ALONG WITH TECHNO-COMMERCIAL OFFER. PARTIES SHALL ALSO INTIMATE BHEL IN RESPECT OF SUCH TRANSACTIONS THROUGH E-MAIL AT amit.kumar@bhel.in/cvksingh@bhel.in. EFT DETAILS OF BHEL ARE AS FOLLOWS (DULY FILLED AND SIGNED FORM IS ALSO ATTACHED):</p> <p><b>IN CASE OF FOREIGN BIDDERS, E-PAYMENT FOR EMD/TENDER COST IS ACCEPTABLE.</b></p> <p>EMD BY THE TENDERER WILL BE FORFEITED AS PER THE TENDER DOCUMENT S(SCHEDULE), IF THE SUCCESSFUL BIDDER/VENDOR REFUSES TO HONOR THE ORDER AFTER AWARD OF THE SAME ON HIM AND/OR WITHDRAWS HIS BID AND/OR UNILATERALLY CHANGES THE OFFER AND/OR ANY OF ITS TERMS&amp; CONDITIONS WITHIN THE VALIDITY PERIOD OR FAILS TO SUBMIT PBG EVEN WITHIN 60 DAYS FROM THE DATE OF PO.</p> <p>EMD GIVEN BY ALL UNSUCCESSFUL TENDERES SHALL BE REFUNDED ON ACCEPTANCE OF AWARD / LOI/ PO BY SUCCESSFUL TENDERER. THE EMD OF SUCCESSFUL BIDDER</p>	

**GENERAL COMMERCIAL TERMS & CONDITIONS OF ENQUIRY FOR CAPITAL ITEM PURCHASE  
(FOR INDIAN AS WELL AS FOREIGN VENDORS)**

ANNEXURE-Z

	<p>SHALL BE RETURNED AFTER SUBMISSION OF CONTRACT EXECUTION BANK GUARANTEE.</p> <p>BANK DETAILS (EFT), BHEL-HERP, VARANASI</p> <p>BANK NAME STATE BANK OF INDIA IFSC CODE SBIN000201 ACCOUNT NUMBER 11103264820 BRANCH CODE 0201 ADDRESS STATE BANK OF INDIA, MAIN BRANCH KACHAHERI, VARANASI. PAN NO AAACB4146P GST NO 09AAACB4146P2ZC</p>	
23	<p><b>P.B.G. TERMS:</b> THE VENDOR IS REQUIRED TO SUBMIT A PERFORMANCE BANK GUARANTEE ON THE PRESCRIBED BHEL FORMAT ANNEXURE-PBG FROM ANY OF THE CONSORTIUM BANKS OF BHEL EQUAL TO THE VALUE OF 10% (TEN PERCENT) OF THE TOTAL ORDER VALUE VALID FOR 60 DAYS BEYOND THE AGREED WARRANTY / GUARANTEE PERIOD. THE PBG CONFIRMATION CHARGES IS TO BE BORNE BY VENDOR.</p> <p>PERFORMANCE BANK GUARANTEE OF FOREIGN SUPPLIERS SHOULD BE CONFIRMED BY OUR CONSORTIUM BANK IN INDIA AND ARE PAYABLE IN INDIA.</p> <p>PERFORMANCE BANK GUARANTEE SHALL BE RELEASED ON APPLICATION BY THE VENDOR /CONTRACTOR AFTER COMMISSIONING OF THE EQUIPMENT AND AFTER HE HAS DISCHARGED ALL HIS OBLIGATIONS UNDER THE CONTRACT AND PRODUCED A CERTIFICATE FROM BHEL, CERTIFYING DUE COMPLETION OF THE WORK.</p>	
24	<p><b>DETAILS ON CAPACITY /SUPPLY AND E&amp;C- PERFORMANCE OF THE VENDOR:</b></p> <p>THE FOLLOWING DETAILS SHALL BE FILLED BY THE VENDOR IN THE ANNEXURE I OF THIS TENDER (ATTACHED WITH THIS TENDER) AND SUBMITTED ALONG WITH TECHNICAL BID (PART-I) :</p> <p>(A) CAPACITY DETAILS IN PART (A) ARE ABOUT THE MANUFACTURING CAPACITY (MAJOR MACHINE: CATEGORY-WISE &amp; NUMBER-WISE), NO. OF MACHINES SUPPLIED DURING LAST 5 YEARS, OUTSTANDING ORDER BOOK POSITION, LIQUIDATION PLAN OF ALL MACHINES INCLUDING BHEL MACHINES UNDER CONSIDERATION FOR ORDERING. WHEREVER POSSIBLE, EFFORTS ARE TO BE MADE TO CONTACT SOME OF THE REFERENCES OF PAST SUPPLIES GIVEN.</p> <p>(B) THE PERFORMANCE DETAILS OF SUPPLIES TO BHEL IS SOUGHT IN PART (B) FOR THE POS PLACED BY BHEL WHICH CAN BE VERIFIED; HENCE SUBMISSION OF THESE INFORMATION BY VENDORS IS MANDATORY. BHEL WILL RESERVE THE RIGHT TO REJECT THE OFFER, IF PAST PERFORMANCE OF THE BIDDER IS EVALUATED TO BE UNSATISFACTORY AND / OR FALSE INFORMATION IS GIVEN BY THE BIDDER.</p> <p>THE ACTUAL / LIKELY SUPPLY AND E&amp;C PERIOD VIS-À-VIS SCHEDULED SUPPLY AND E&amp;C PERIOD (DELAY FOR REASONS ATTRIBUTABLE TO VENDOR ONLY TO BE CONSIDERED) SHALL BE CONSIDERED FOR ALL THE MACHINES AGAINST THE POS PLACED BY BHEL DURING LAST 5 YEARS (LIMITED TO 5 LATEST EXECUTED POS) AND ALL POS OVERDUE FOR SUPPLY AND/OR E&amp;C.</p>	
25	<p><b>DETAILS ON CAPACITY /SUPPLY AND E&amp;C- PERFORMANCE OF THE VENDOR: CONTINUED</b></p> <p>FOR PURPOSE OF CALCULATION OF DELIVERY INDEX IN CASE OF OVERDUE POS, THE DELAY PERIOD FOR SUPPLY AND/OR E&amp;C WILL BE RECKONED FROM THE DATE OF BID OPENING OF THE TENDER UNDER EVALUATION. IN CASE OF TWO-PART BID, PART-I (I.E TECHNO-COMMERCIAL BID) SHALL BE CONSIDERED AS DATE OF BID OPENING. EARLY SUPPLY AND/OR E&amp;C VIS-À-VIS SCHEDULED DATES WILL NOT BE ENTITLED FOR ANY CONSIDERATION FOR CALCULATION OF DELIVERY INDEX. DELAY IN E&amp;C SHALL BE APPLICABLE ONLY IN SUCH CASES WHERE E&amp;C PERIOD HAS BEEN MENTIONED IN THE PO.</p> <p>IN CASE A PO INCLUDES MORE THAN ONE MACHINE, THEN ALL THE MACHINES OF THE PO SHALL BE CONSIDERED FOR CALCULATION OF DELIVERY INDEX. ILLUSTRATION FOR CALCULATION OF DELIVERY INDEX:</p> $DELIVERY\ INDEX = \sum_{I=1}^N \frac{((\Delta X_I + \Delta Y_I))}{((X_I + Y_I))} / N$ <p>I = NO. OF MACHINES; WHERE, I = 1..... TO N (N = NO. OF M/CS.) X<sub>I</sub> = SCHEDULED DELIVERY (NO. OF DAYS) ΔX<sub>I</sub> = SUPPLY DELAY (NO. OF DAYS) Y<sub>I</sub> = SCHEDULED E&amp;C (NO. OF DAYS) ΔY<sub>I</sub> = E&amp;C DELAY (NO. OF DAYS)</p> <p>IF DELIVERY INDEX OF ANY BIDDER IS ≥ 0.20, THEN THE PARTICULAR OFFER SHALL BECOME LIABLE FOR REJECTION. HOWEVER, BHEL RESERVES THE RIGHT TO ACCEPT OFFERS WITH DELIVERY INDEX ≥ 0.20 AGAINST JUSTIFIED REASONS.</p>	
26	<p><b>LIQUIDATED DAMAGES (LD):</b></p> <ol style="list-style-type: none"> <li>1. TIME IS THE ESSENCE OF THE CONTRACT. THE ORDERED ITEMS SHALL BE DELIVERED AND COMMISSIONED AS PER THE DELIVERY PERIOD MENTIONED IN THE PURCHASE ORDER.</li> <li>2. FAILURE TO SUPPLY AND/OR COMPLETION OF E&amp;C WITHIN THE DELIVERY TIME AS PER PURCHASE ORDER WILL MAKE THE VENDOR LIABLE TO AN UNCONDITIONAL PENALTY.</li> <li>3. <b>THE PERIOD FOR CALCULATING DELAY IN SUPPLY FOR PURPOSE OF LD CALCULATION SHALL BE AS UNDER:</b> <p><b>FOR INDIAN BIDDERS:</b> LD FOR DELAYED SUPPLY SHALL BE CALCULATED FROM THE SCHEDULED DELIVERY DATE AS PER PO TO THE DATE OF RECEIPT OF MACHINE AT BHEL HERP STORES i.e. SRV Date. PDI CALL SHALL BE GIVEN ATLEAST 15 DAYS IN ADVANCE FOR TRAVEL DOCUMENTATIONS AND OTHER REQUIREMENTS.</p> <p><b>FOR FOREIGN BIDDERS:</b> LD FOR DELAYED SUPPLY SHALL BE CALCULATED FROM THE SCHEDULED DELIVERY DATE AS PER PO (i.e. 9 MONTHS FOM PO DATE) <b>TO THE DATE OF BILL OF LADING.</b> PRE DISPATCH INSPECTION (PDI) CALL SHALL BE GIVEN ATLEAST 30 DAYS IN ADVANCE FOR TRAVEL DOCUMENTATIONS AND OTHER REQUIREMENTS.</p> </li> <li>4. <b>THE PERIOD FOR CALCULATING E&amp;C DELAY FOR LD CALCULATION SHALL BE AS UNDER:</b> <b>FOR INDIAN BIDDERS AND FOR FOREIGN BIDDERS</b></li> </ol>	

**GENERAL COMMERCIAL TERMS & CONDITIONS OF ENQUIRY FOR CAPITAL ITEM PURCHASE  
(FOR INDIAN AS WELL AS FOREIGN VENDORS)**

ANNEXURE-Z

	<p>LD FOR DELAYED E &amp; C SHALL BE CALCULATED FROM THE SCHEDULED COMMISSIONING DATE AS PER PO (i.e. WITHIN 60 DAYS OF RECEIPT OF INTIMATION FROM BHEL FOR SITE READINESS) TO DATE OF COMMISSIONING CERTIFICATE.</p> <p>BHEL IS NOT LIABLE FOR DELAYED OA FOR OPENING LC OR CORRECTIONS/AMENDMENT TO LC ASKED AFTER OPENING OF LC.</p> <p><b>APPLICABLE PENALTY: -</b></p> <p>FOR THE PURPOSE OF PENALTY, FOR DELAY IN E&amp;C OF THE EQUIPMENT THE DURATION WILL BE RECKONED FROM THE DATE OF INTIMATION BY BHEL TO VENDOR FOR READINESS OF SITE.</p> <p>PENALTY ON DELAY IN 'SUPPLY' AND/OR 'E&amp;C' WILL BE APPLICABLE TO THE DELAYS ATTRIBUTED TO VENDOR. PENALTY WILL BE CONSIDERED SEPARATELY FOR 'SUPPLY' AND 'E&amp;C'.</p> <p>THE RATE OF PENALTY FOR DELAYED SUPPLY SHALL BE @ 0.5% PER WEEK OF DELAY OF TOTAL PO VALUE (SUPPLY + E&amp;C) IN SUPPLY SUBJECT TO A MAXIMUM OF 10% OF TOTAL PO VALUE (SUPPLY + E&amp;C).</p> <p>THE RATE OF PENALTY FOR DELAYED E&amp;C SHALL BE @ 0.5% PER WEEK OF DELAY OF TOTAL PO VALUE (SUPPLY E&amp;C) IN E&amp;C SUBJECT TO A MAXIMUM OF 10% OF TOTAL PO VALUE (SUPPLY + E&amp;C).</p> <p>MAXIMUM PENALTY FOR DELAY IN SUPPLY AND E&amp;C TOGETHER SHALL BE LIMITED TO 15% OF TOTAL PO VALUE (SUPPLY + E&amp;C).</p> <p>IN CASE ANY BIDDER IS NOT ACCEPTING THE ABOVE PENALTY FOR DELAYED SUPPLY AND/OR E&amp;C, THE OFFER OF BIDDER SHALL BE LOADED TO THE EXTENT TO WHICH IT IS NOT AGREED BY THE BIDDER. THE EXTRA LOADING WILL BE INTIMATED BEFORE OPENING OF PRICE BID OR REVERSE AUCTION BY BHEL.</p> <p>GENERAL: -</p> <p>IN CASE, ANY SHORTAGE IS NOTICED VIZ-A-VIZ PO REQUIREMENT IN THE MAIN EQUIPMENT / SPARES, SUCH SHORTAGES SHALL BE REPLENISHED BY SUPPLIER ON FOR DESTINATION BASIS WITHOUT ANY COST IMPLICATION TO BHEL I.E. CUSTOM DUTY AND FREIGHT CHARGES ETC. UP TO DESTINATION FOR SUCH SHORT SUPPLIES SHALL BE BORNE BY THE SUPPLIER.</p> <p>SUPPLY PERIOD INDICATED BY BIDDER SHOULD INCLUDE REASONABLE TIME REQUIRED FOR APPROVAL OF DRAWINGS AND OTHER INPUTS FROM BHEL. IN THE TECHNO-COMMERCIAL BID, THE BIDDER SHALL SUBMIT MILESTONES FOR VARIOUS ACTIVITIES IN CO-RELATION WITH SUPPLY AND E&amp;C PERIOD QUOTED BY HIM.</p> <p>VENDORS ARE REQUESTED TO QUOTE FOR THIS TENDER. ANY INTIMATION REGARDING CHANGES IN TECHNICAL OR COMMERCIAL, DURING TENDER EVALUATION, WILL BE INTIMATED ONLY TO THE VENDORS WHO HAVE PARTICIPATED IN THIS TENDER.</p>	
27	<p><b>LOADING OF LIQUIDATED DAMAGES (LD):</b></p> <p>IN CASE ANY BIDDER IS NOT ACCEPTING THE ABOVE LD CLAUSE FOR DELAYED SUPPLY AND/OR E&amp;C, THE OFFER OF BIDDER SHALL BE LOADED TO THE EXTENT TO WHICH IT IS NOT AGREED BY THE BIDDER.</p>	
28	<p><b>DELIVERY PERIOD:</b> DELIVERY PERIOD SHALL BE AS PER CLAUSE 16 OF ANNEXURE-A.</p>	
29	<p>IF ANY VENDOR DOES NOT SUPPLY THE ITEM WITHIN THE PURCHASE ORDER DELIVERY PERIOD, BHEL MAY/MAY NOT ACCEPT THE SUPPLY AT ITS SOLE DISCRETION.</p>	
30	<p><b>REVERSE AUCTION:</b> BHEL MAY BE RESORTING TO REVERSE AUCTION (RA) (GUIDELINES AS AVAILABLE ON <a href="http://WWW.BHEL.COM">WWW.BHEL.COM</a>) FOR THIS TENDER. RA MAY CONDUCTED AMONG ALL THE TECHNO-COMMERCIALY QUALIFIED BIDDERS AS PER ACUTAL SITUATION AFTER PART-1 OPENING.</p> <p>PRICE BIDS OF ALL TECHNO-COMMERCIALY QUALIFIED BIDDERS SHALL BE OPENED AND SAME SHALL BE CONSIDERED AS INITIAL BIDS OF BIDDERS IN RA. IN CASE ANY BIDDER(S) DO (ES) NOT PARTICIPATE IN ONLINE REVERSE AUCTION, THEIR SEALED ENVELOPE PRICE BID ALONG WITH APPLICABLE LOADING, IF ANY, SHALL BE CONSIDERED FOR RANKING.</p>	
31	<p>IF ANY OF THE VENDORS DO NOT ACCEPT THE ABOVE POINT MENTIONED AT SL. NO. 28, THEIR OFFER MAY BE LIABLE FOR REJECTION WITHOUT INTIMATION.</p>	
32	<p><b>RISK PURCHASE:</b> IN CASE OF DELAY IN SUPPLIES/ DEFECTIVE SUPPLIES/NON EXECUTION OF PURCHASE ORDER ETC. (FOR DETAILS, REFER GUIDELINES FOR RISK PURCHASE), BHEL MAY CANCEL THE ORDER IN FULL OR PART THEREOF/ MAY ALSO MAKE THE PURCHASE OF SUCH MATERIALS FROM ELSEWHERE/ALTERNATIVE SOURCES AT THE RISK &amp; COST OF SUPPLIER.BHEL MAY ALSO MANUFACTURE THE ITEM IN-HOUSE IN PART OR FULL DEPENDING UPON THE URGENCY OF THE ITEM. GUIDELINES FOR <b>RISK PURCHASE</b> IS AVAILABLE ON BHEL WEBSITE "<a href="https://herp.bhel.com">https://herp.bhel.com</a>" at "<b>Notice</b>". RESPECTIVE BIDDERS / SUPPLIERS MAY REFER THIS GUIDELINE BEFORE SUBMITTING THEIR OFFER AGAINST BHEL, HERP TENDER ENQUIRIES. IN CASE RISK PURCHASE IS APPLIED, BHEL SHALL TAKE ACTION AGAINST THE NON-PERFORMING AND/OR DEFAULTING SUPPLIERS/ CONTRACTORS IN LINE WITH THIS GUIDELINE ONLY.</p>	
33	<p>BHEL MAY SHORT CLOSE/CANCEL AN ORDER AT ANY TIME DURING THE CURRENCY OF THE CONTRACT/PO IRRESPECTIVE OF THE PO DELIVERY DATE, IF</p> <p>(I) THE WORK PROGRESS OF THE VENDOR IS POOR, OR</p> <p>(II) THE DELIVERY REQUIREMENT OF THE ITEM IS VERY CRITICAL &amp; NOT BEING MET BY THE VENDOR ON WHICH ORDER HAS BEEN PLACED, OR</p> <p>(III) THERE IS NO RESPONSE FOR IMPROVEMENT IN DELIVERY AS PER BHEL REQUIREMENT,</p>	
34	<p>THE OFFERS OF THE BIDDERS WHO ARE ON THE BANNED LIST AND ALSO THE OFFER OF THE BIDDERS, WHO ENGAGE THE SERVICES OF THE BANNED FIRMS, SHALL BE REJECTED. THE LIST OF BANNED FIRMS IS AVAILABLE ON BHEL WEB SITE <a href="http://www.bhel.com">www.bhel.com</a></p>	
35	<p><b>RESERVATION RIGHTS OF BHEL:</b> – BHEL RESERVES THE RIGHT TO REJECT ANY OR ALL QUOTATIONS WITHOUT ASSIGNING ANY REASONS THEREOF. BHEL ALSO RESERVES THE RIGHT TO INCREASE OR DECREASE THE TENDERED QUANTITIES. VENDORS SHOULD BE PREPARED TO ACCEPT ORDER FOR REDUCED QUANTITIES WITHOUT ANY EXTRA CHARGES. VENDOR SHOULD ALSO BE PREPARED FOR GIVING DISCOUNT IN CASE OF INCREASE IN QUANTITY.</p>	
36	<p><b>NON-DISCLOSURE AGREEMENT:</b> ALL DRAWINGS AND STANDARDS ARE PROPRIETARY OF BHEL. IT MUST NOT BE USED IN ANY WAY DETRIMENTAL TO THE INTEREST OF THE COMPANY. ALL SUPPLIERS SHALL FURNISH NDA (NON-DISCLOSURE AGREEMENT) AGAINST USE OF DOCUMENTS FURNISHED BY BHEL TOWARDS UN-AUTHORIZED USE EXCEPT FOR THE PURPOSE IT HAS BEEN FURNISHED.</p>	
37	<p><b>A. SETTLEMENT OF DISPUTES &amp; ARBITRATION:</b></p> <p><b>A.1 ARBITRATION:</b></p> <p>EXCEPT AS PROVIDED ELSEWHERE IN THIS CONTRACT, IN CASE PARTIES ARE UNABLE TO REACH AMICABLE SETTLEMENT (WHETHER BY CONCILIATION TO BE CONDUCTED AS PROVIDED IN CLAUSE A.2 HEREIN BELOW OR OTHERWISE) IN RESPECT OF ANY DISPUTE OR DIFFERENCE; ARISING OUT OF THE FORMATION, BREACH, TERMINATION, VALIDITY OR EXECUTION OF THE CONTRACT; OR, THE RESPECTIVE RIGHTS AND LIABILITIES OF THE PARTIES; OR, IN RELATION TO INTERPRETATION OF ANY PROVISION OF THE CONTRACT; OR, IN ANY MANNER TOUCHING UPON THE CONTRACT (HEREINAFTER REFERRED TO AS THE 'DISPUTE'), THEN, EITHER PARTY MAY, COMMENCE ARBITRATION IN RESPECT OF SUCH DISPUTE BY ISSUANCE OF A NOTICE IN TERMS OF SECTION 21 OF THE ARBITRATION &amp; CONCILIATION ACT, 1996 (HEREINAFTER REFERRED TO AS THE 'NOTICE'). THE NOTICE SHALL BE ADDRESSED TO THE HEAD OF THE BHEL VARANASI ISSUING THE CONTRACT AND SHALL CONTAIN THE PARTICULARS OF ALL CLAIMS TO BE REFERRED TO ARBITRATION IN SUFFICIENT DETAIL AND SHALL ALSO INDICATE THE MONETARY AMOUNT OF SUCH CLAIM. WITHIN 60 DAYS OF RECEIPT OF THE COMPLETE NOTICE, THE HEAD OF THE BHEL VARANASI ISSUING THE CONTRACT SHALL OFFER NAMES OF THREE PROPOSED</p>	

**GENERAL COMMERCIAL TERMS & CONDITIONS OF ENQUIRY FOR CAPITAL ITEM PURCHASE  
(FOR INDIAN AS WELL AS FOREIGN VENDORS)**

ANNEXURE-Z

	<p>ARBITRATORS TO THE INVOKING PARTY ADVISING TO CHOOSE ANY ONE OF THE THREE NAMES TO BE APPOINTED AS SOLE ARBITRATOR. ON GETTING CONFIRMATION FROM THE INVOKING PARTY REGARDING THE ARBITRATOR CHOSEN FROM AMONG THE NAMES SO OFFERED, THE HEAD OF THE BHEL VARANASI ISSUING THE CONTRACT, SHALL APPOINT SUCH CHOSEN PERSON AS THE SOLE ARBITRATOR FOR CONDUCTING THE ARBITRATION. THE LANGUAGE OF ARBITRATION SHALL BE ENGLISH.</p> <p>THE ARBITRATOR SHALL PASS A REASONED AWARD.</p> <p>SUBJECT AS AFORESAID, THE PROVISIONS OF ARBITRATION AND CONCILIATION ACT 1996 (INDIA) OR STATUTORY MODIFICATIONS OR RE-ENACTMENTS THEREOF AND THE RULES MADE THEREUNDER AS IN FORCE FROM TIME TO TIME SHALL APPLY TO THE ARBITRATION PROCEEDINGS UNDER THIS CLAUSE. THE SEAT OF ARBITRATION SHALL BE VARANASI (THE PLACE FROM WHERE THE CONTRACT IS ISSUED). THE CONTRACT SHALL BE GOVERNED BY AND BE CONSTRUED AS PER PROVISIONS OF THE LAWS OF INDIA. SUBJECT TO THIS PROVISION 2.21.1.1 REGARDING ARBITRATION, THE PRINCIPAL CIVIL COURT EXERCISING ORDINARY CIVIL JURISDICTION OVER THE AREA WHERE THE SEAT OF ARBITRATION IS LOCATED SHALL HAVE EXCLUSIVE JURISDICTION OVER ANY DISPUTE TO THE EXCLUSION OF ANY OTHER COURT.</p> <p>IN CASE OF CONTRACT WITH PUBLIC SECTOR ENTERPRISE (PSE) OR A GOVERNMENT DEPARTMENT, THE FOLLOWING SHALL BE APPLICABLE:</p> <p>IN THE EVENT OF ANY DISPUTE OR DIFFERENCE RELATING TO THE INTERPRETATION AND APPLICATION OF THE PROVISIONS OF COMMERCIAL CONTRACT(S) BETWEEN CENTRAL PUBLIC SECTOR ENTERPRISES (CPSES) / PORT TRUSTS INTER SE AND ALSO BETWEEN CPSES. AND GOVERNMENT DEPARTMENTS/ORGANIZATIONS (EXCLUDING DISPUTES RELATING TO RAILWAYS, INCOME TAX, CUSTOMS &amp; EXCISE DEPARTMENTS), SUCH DISPUTE OR DIFFERENCE SHALL BE TAKEN UP BY EITHER PARTY FOR ITS RESOLUTION THROUGH AMRCD AS MENTIONED IN DPE OM NO. 05/0003/2019-FTS-10937 DATED 14TH DECEMBER, 2022 AND THE DECISION OF AMRCD ON THE SAID DISPUTE WILL BE BINDING ON BOTH THE PARTIES.</p> <p>THE COST OF ARBITRATION SHALL INITIALLY BE BORNE EQUALLY BY THE PARTIES SUBJECT TO THE FINAL ALLOCATION THEREOF AS PER THE AWARD/ORDER PASSED BY THE ARBITRATOR.</p> <p>NOTWITHSTANDING THE EXISTENCE OF ANY DISPUTE OR DIFFERENCES AND/OR REFERENCE FOR THE ARBITRATION, THE VENDOR SHALL PROCEED WITH AND CONTINUE WITHOUT HINDRANCE THE PERFORMANCE OF ITS OBLIGATIONS UNDER THIS CONTRACT WITH DUE DILIGENCE AND EXPEDITION IN A PROFESSIONAL MANNER UNLESS THE DISPUTE INTER-ALIA RELATES TO CANCELLATION, TERMINATION OR SHORT-CLOSURE OF THE CONTRACT BY BHEL.</p> <p><b>A.2 CONCILIATION:</b></p> <p>IF AT ANY TIME (WHETHER BEFORE, DURING OR AFTER THE ARBITRAL OR JUDICIAL PROCEEDINGS), ANY DISPUTES (WHICH TERM SHALL MEAN AND INCLUDE ANY DISPUTE, DIFFERENCE, QUESTION OR DISAGREEMENT ARISING IN CONNECTION WITH CONSTRUCTION, MEANING, OPERATION, EFFECT, INTERPRETATION OR BREACH OF THE AGREEMENT, CONTRACT), WHICH THE PARTIES ARE UNABLE TO SETTLE MUTUALLY, ARISE INTER-SE THE PARTIES, THE SAME MAY, BE REFERRED BY EITHER PARTY TO CONCILIATION TO BE CONDUCTED THROUGH INDEPENDENT EXPERTS COMMITTEE (IEC) TO BE APPOINTED BY COMPETENT AUTHORITY OF BHEL FROM THE BHEL PANEL OF CONCILIATORS.</p> <p>NOTES: NO SERVING OR A RETIRED EMPLOYEE OF BHEL/ADMINISTRATIVE MINISTRY OF BHEL SHALL BE INCLUDED IN THE BHEL PANEL OF CONCILIATORS.</p> <p>ANY OTHER PERSON(S) CAN BE APPOINTED AS CONCILIATOR(S) WHO IS/ARE MUTUALLY AGREEABLE TO BOTH THE PARTIES FROM OUTSIDE THE BHEL PANEL OF CONCILIATORS.</p> <p>THE PROCEEDINGS OF CONCILIATION SHALL BROADLY BE GOVERNED BY PART-III OF THE ARBITRATION AND CONCILIATION ACT 1996 OR ANY STATUTORY MODIFICATION THEREOF AND AS PROVIDED IN PROCEDURE 2.3 TO THIS GCC. THE PROCEDURE 2.3 TOGETHER WITH ITS FORMATS WILL BE TREATED AS IF THE SAME IS PART AND PARCEL HEREOF AND SHALL BE AS EFFECTUAL AS IF SET OUT HEREIN IN THIS GCC.</p> <p>THE VENDOR HEREBY AGREES THAT BHEL MAY MAKE ANY AMENDMENTS OR MODIFICATIONS TO THE PROVISIONS STIPULATED IN THE PROCEDURE A.3 TO THIS GCC FROM TIME TO TIME AND CONFIRMS THAT IT SHALL BE BOUND BY SUCH AMENDED OR MODIFIED PROVISIONS OF THE PROCEDURE A.3 WITH EFFECT FROM THE DATE AS INTIMATED BY BHEL TO IT.</p> <p><b>A.3 ISSUE OF NOTICE</b></p> <p><b>A.3.1 SERVICE OF NOTICE ON VENDOR</b></p> <p>ANY NOTICE TO BE GIVEN TO THE VENDOR UNDER THE TERMS OF THE CONTRACT SHALL BE SERVED BY SENDING THE SAME BY REGISTERED POST/SPEED POST TO OR LEAVING THE SAME AT THE VENDOR'S LAST KNOWN ADDRESS OF THE PRINCIPAL PLACE OF BUSINESS (OR IN THE EVENT OF THE VENDOR BEING A COMPANY, TO OR AT ITS REGISTERED OFFICE). IN CASE OF CHANGE OF ADDRESS, THE NOTICE SHALL BE SERVED AT CHANGED ADDRESS AS NOTIFIED IN WRITING BY THE VENDOR TO BHEL. SUCH POSTING OR LEAVING OF THE NOTICE SHALL BE DEEMED TO BE GOOD SERVICE OF SUCH NOTICE AND THE TIME MENTIONED TO THE CONDITION FOR DOING ANY ACT AFTER NOTICE SHALL BE RECKONED FROM THE DATE SO MENTIONED IN SUCH NOTICE.</p> <p><b>A.3.2 SERVICE OF NOTICE ON BHEL</b></p> <p>ANY NOTICE TO BE GIVEN TO BHEL IN-CHARGE/REGION UNDER THE TERMS OF THE CONTRACT SHALL BE SERVED BY SENDING THE SAME BY POST TO OR LEAVING THE SAME AT BHEL ADDRESS OR CHANGED ADDRESS AS NOTIFIED IN WRITING BY BHEL TO THE VENDOR.</p> <p><b>B. JURISDICTION:</b> ALL DISPUTES OR DIFFERENCES ARISING OUT OF OR IN CONNECTIONS WITH THE CONTRACT SHALL BE SUBJECT TO THE EXCLUSIVE JURISDICTION OF THE COURT AT VARANASI (U.P.), INDIA ONLY.</p>	
38	<p><b>APPLICABLE LAWS: -</b></p> <p>THE ORDER/CONTRACT SHALL BE EXECUTED AND GOVERNED BY THE LAWS OF INDIA AND THE COURTS OF VARANASI (U.P.), INDIA ALONE SHALL HAVE JURISDICTION IN RESPECT OF ANY MATTER ARISING UNDER OR IN CONNECTION WITH THE ORDER/CONTRACT WITHOUT REGARD TO CONFLICT OF LAW PRINCIPLES.</p> <p><b>CHANGE IN LAW: -</b></p> <p>IN CASE OF CHANGE IN ANY LAW RELATED TO THIS CONTRACT, NEW/ MODIFIED/REVISED LAW WILL BE APPLICABLE AS PER APPLICABILITY.</p>	
39	<p><b>SPECIAL NOTE FOR BIDDERS:</b> THE QUOTATION SHOULD BE FROM PRINCIPAL / ORIGINAL EQUIPMENT MANUFACTURER ONLY. THE OFFER OF THOSE OEM, AUTHORIZING THEIR TRADER / DEALER / DISTRIBUTOR TO QUOTE AND TAKE ORDER IS LIABLE FOR DISQUALIFICATION. SINCE BHEL PREFER TO DEAL DIRECTLY WITH OEM AND NOT THROUGH DEALER / TRADER / DISTRIBUTOR OF OEM, THEREFORE, OEM MUST DIRECTLY QUOTE, TAKE ORDER AND DELIVER THE MATERIAL UNDER THEIR GUARANTEE / WARRANTEE.</p>	

**GENERAL COMMERCIAL TERMS & CONDITIONS OF ENQUIRY FOR CAPITAL ITEM PURCHASE  
(FOR INDIAN AS WELL AS FOREIGN VENDORS)**

ANNEXURE-Z

40	<b>THE EVALUATION OF CURRENCY FOR THIS TENDER SHALL BE INR.</b> FOR EVALUATION, EXCHANGE RATE (TT SELLING RATE OF SBI) AS ON SCHEDULED DATE OF TENDER OPENING (PART-1 BID IN CASE OF TWO PART BID) SHALL BE CONSIDERED.	
41	<b>GUIDELINES REGARDING DEALINGS WITH INDIAN AGENTS OF FOREIGN SUPPLIERS (IF APPLICABLE): -</b> BHEL SHALL DEAL DIRECTLY WITH THE FOREIGN ORIGINAL EQUIPMENT MANUFACTURERS (OEM) / FOREIGN PRINCIPAL, FOR ALL ITS PURCHASES WHICH ARE IMPORTED. WHEREVER THE FOREIGN OEM / PRINCIPAL DESIRES TO AVAIL THE SERVICES OF AN INDIAN AGENT, THE DEALINGS WITH INDIAN AGENT ARE TO BE REGULATED. THE GUIDELINES OF BHEL IN THIS REGARD HAVE BEEN DRAFTED AS PER <b>ANNEXURE – III, ANNEXURE A-1 &amp; ANNEXURE B-1</b> ATTACHED ALONG WITH THIS ENQUIRY. FOREIGN OEM / PRINCIPAL SHOULD ENSURE COMPLIANCE TO THESE REGULATORY GUIDELINES WITH DOCUMENTARY EVIDENCE & CONFIRM THEIR ACCEPTANCE.	
42	ALL THE NECESSARY DOCUMENTS REQUIRED AS PER ANNEXURE B-1 (PART B) HAS BEEN ENCLOSED ALONG WITH THE TECHNO-COMMERCIAL BID (FOR FOREIGN VENDORS ONLY).  FOREIGN VENDORS MUST SUBMIT THE OFFER AS WELL ANY CLARIFICATIONS, IN ENGLISH LANGUAGE ONLY	
43	IN A TENDER, EITHER THE INDIAN AGENT ON BEHALF OF THE PRINCIPAL/OEM OR PRINCIPAL/OEM ITSELF CAN BID BUT BOTH CANNOT BID SIMULTANEOUSLY FOR THE SAME ITEM/PRODUCT IN THE SAME TENDER. IN CASE BIDS ARE RECEIVED FROM BOTH, I.E. PRINCIPAL (OEM) AND THE AGENT, BID RECEIVED FROM THE AGENT WILL BE IGNORED.	
44	<b>INSPECTION CHARGES FOR FOREIGN BIDDERS:</b> AS PER CLASUE 7 & 11 OF THE ANNEXURE-A.	
45	<b>NO INTEREST PAYABLE TO CONTRACTOR</b>  NOTWITHSTANDING ANYTHING TO THE CONTRARY CONTAINED IN ANY OTHER DOCUMENT COMPRISING IN THE CONTRACT, NO INTEREST SHALL BE PAYABLE BY BHEL TO VENDOR/CONTRACTOR ON ANY MONEYS OR BALANCES INCLUDING BUT NOT LIMITED TO THE SECURITY DEPOSIT, CEBG, PBG, EMD, RETENTION MONEY, BILLS OR THE FINAL BILL, OR ANY AMOUNT WITHHELD AND/OR APPROPRIATED BY BHEL ETC., WHICH BECOMES OR AS THE CASE MAY BE, IS ADJUDGED TO BE DUE FROM BHEL TO VENDOR/ CONTRACTOR WHETHER UNDER THE CONTRACT OR OTHERWISE.	
46	<b>(A) FOR INDIAN SUPPLIERS:</b> I. FOLLOWING DOCUMENTS SHOULD BE ENCLOSED AND ADDRESSED TO DGM (FINANCE) AND SAME SHALL BE DISPATCHED TO MM DEPTT. BHEL, HERP, TARNA, SHIVPUR, VARANASI-221003 FOR PAYMENT PURPOSE: a) 05 (FIVE) COPIES OF GST INVOICES  b) COPY OF GR/RR.  c) TEST CERTIFICATE AND GUARANTEE/WARRANTEE CERTIFICATE AND PDI REPORT, IF APPLICABLE. (ONE COPY).  II. FURTHER TO ABOVE, 02 (TWO) COMPLETE SETS OF DOCUMENTS (COPIES OF ABOVE MENTIONED DOCUMENTS AT SL. NO. I FOR INDIAN SUPPLIERS (UNDER THIS CLAUSE) SHALL BE SENT FOR PURCHASE AND QUALITY DEPARTMENTS. ORIGINAL COPIES OF TC, GC, PDI REPORTS & OTHER QUALITY PAPERS SHALL BE ATTACHED IN THE SET OF DOCUMENTS FOR QUALITY DEPARTMENTS.  <b>(B) FOR FOREIGN SUPPLIERS:</b> DOCUMENTS SHALL BE ROUTED FOR PAYMENT AS WELL AS CUSTOM CLEARANCE AS PER BELOW DETAILS: I.FOLLOWING MENTIONED DOCUMENTS SHOULD BE ROUTED TO THE BANK AGAINST LC /BANK PAYMENT: a) ORGINAL INVOICES.  b) ORIGINAL COPY OF BILL OF LADING OR AIR WAY BILL.  c) TEST CERTIFICATE AND GUARANTEE/WARRANTEE CERTIFICATE AND PDI REPORT, IF APPLICABLE. (ONE COPY).  d) PACKING LIST.  e) CERTIFICATE FOR COUNTRY OF ORIGIN.  f) OTHER CERTIFICATES/PAPERS AS REQUIRED IN PURCHASE ORDER.  II. ONE SET OF NON - NEGOTIABLE' DOCUMENTS INCLUDING COPY BILL OF LADING / AIR WAY BILL, INVOICE, PACKING LIST, TEST CERTIFICATE, GUARANTEE CERTIFICATE, PDI REPORT (AS APPLICABLE) etc. TO BE SENT TO GENERAL MANAGER, BHARAT HEAVY ELECTRICCLAS LIMITED – REGIONAL OPERATION DIVISION, 14 /15th FLOOR), WORLD TRADE CENTRE-1, CUFFE PARADE, MUMBAI - 400005 (INDIA).  III. ONE SET EACH OF NON - NEGOTIABLE' DOCUMENTS INCLUDING COPY BILL OF LADING / AIR WAY BILL, INVOICE, PACKING LIST, TEST CERTIFICATE, GUARANTEE CERTIFICATE, PDI REPORT (AS APPLICABLE) etc. TO BE SENT TO AGM (MM) & AGM (FINANCE), BHARAT HEAVY ELECTRICCLAS LIMITED, HEAVY EQUIPMENT REPAIR PLANT, TARNA, SHIVPUR, VARANASI (INDIA) – 221003 THROUGH COURIER/POST.  <b>(C) BHEL SHALL SEEK CLARIFICATION(S) (IF ANY) RELATED TO PAYMENT DOCUMENTS. THE VENDOR SHOULD PROVIDE ALL SUCH CLARIFICATION(S) IMMEDIETLY.ANY DELAY IN PROCESSING OF PAYMENT, DUE TO NON RECEIPT OF CLARIFICATION(S) SOUGHT BY BHEL, SHALL BE ATTRIBUTABLE COMPLETELY TO VENDOR.</b>	
47	<b>GUIDELINES FOR SUSPENSION OF BUSINESS DEALINGS WITH SUPPLIERS/ CONTRACTORS:</b> THE REVISED GUIDELINES FOR SUSPENSION OF BUSSINESS DEALINGS ARE AVAILABLE ON BHEL WEBSITE AT “www.bhel.com” on “SUPPLIER REGISTRATION PAGE”. RESPECTIVE BIDDERS / SUPPLIERS MAY REFER THIS BEFORE QUOTING AS PER THEIR REQUIREMENT. ACTION AGAINST THE DEFAULTED SUPPLIERS/ CONTRACTORS' SHALL BE TAKEN AS PER THESE GUIDELINES ONLY.	
48	<b>INTEGRITY PACT (IP)</b>  (a) IP IS A TOOL TO ENSURE THAT ACTIVITIES AND TRANSACTIONS BETWEEN THE COMPANY AND ITS BIDDERS/ CONTRACTORS ARE HANDLED IN A FAIR, TRANSPARENT AND CORRUPTION FREE MANNER. FOLLOWING INDEPENDENT EXTERNAL MONITORS (IEMS) ON THE PRESENT PANEL HAVE BEEN APPOINTED BY BHEL WITH THE APPROVAL OF CVC TO OVERSEE IMPLEMENTATION OF IP IN BHEL.  1. SHRI OTEM DAI, IAS (RETD.), email ID: IEM1@BHEL.IN 2. SHRI BISHWAMITRA PANDEY, IRAS (RETD.), email ID: IEM2@BHEL.IN 3. SHRI MUKESH MITTAL, IRS (RETD.), email ID: IEM3@BHEL.IN  (b) THE IP AS ENCLOSED WITH THE TENDER IS TO BE SUBMITTED (DULY SIGNED BY AUTHORIZED SIGNATORY) ALONG WITH TECHNO-COMMERCIAL BID (PART-I, IN CASE OF TWO/ THREE PART BID). ONLY THOSE BIDDERS WHO HAVE ENTERED INTO SUCH AN IP WITH BHEL WOULD BE COMPETENT TO PARTICIPATE IN THE BIDDING. IN OTHER WORDS, ENTERING INTO THIS PACT WOULD BE A PRELIMINARY QUALIFICATION.  (c) PLEASE REFER SECTION-8 OF IP FOR ROLE AND RESPONSIBILITIES OF IEMS. IN CASE OF ANY COMPLAINT ARISING OUT OF THE TENDERING PROCESS, THE MATTER MAY BE REFERRED TO ANY OF THE ABOVE IEM(S). ALL CORRESPONDENCE WITH THE IEMS SHALL BE DONE THROUGH EMAIL ONLY.	

**GENERAL COMMERCIAL TERMS & CONDITIONS OF ENQUIRY FOR CAPITAL ITEM PURCHASE  
(FOR INDIAN AS WELL AS FOREIGN VENDORS)**

ANNEXURE-Z

	<p>Note: *****</p> <p>NO ROUTINE CORRESPONDENCE SHALL BE ADDRESSED TO THE /EM (PHONE/ POST/ EMAIL) REGARDING THE CLARIFICATIONS, TIME EXTENSIONS OR ANY OTHER ADMINISTRATIVE QUERIES, ETC ON THE TENDER ISSUED. ALL SUCH CLARIFICATION/ ISSUES SHALL BE ADDRESSED DIRECTLY TO THE TENDER ISSUING (PROCUREMENT) DEPARTMENT'S OFFICIALS WHOSE CONTACT DETAILS ARE PROVIDED BELOW:</p> <p>Details of contact person(s):</p> <p>(1) Name: AMIT KUMAR Deptt: PURCHASE Address: BHEL HERP TARNA SHIVPUR VARANASI Phone: 05422720873(Landline/ Mobile) Email: amit.kumar@bhel.in</p> <p>(2) UMESH KUMAR GUPTA Deptt: PURCHASE Address: BHEL HERP TARNA SHIVPUR VARANASI Phone: 05422720861(Landline/ Mobile) Email: umesh@bhel.in</p> <p>ANNEXURE-1 (AA: SSP:IP:R03 dtd 01-04-2022) OF IP ALSO BE READ ALONG WITH ABOVE CLAUSE WHICH IS ATACHED WITH NIT.</p>	
49	<b>BONUS CLAUSE: NOT APPLICABLE.</b>	
50	VENDOR MUST FOLLOW THE SEQUENTIAL DELIVERY SCHEDULE i.e. ITEMS TO BE SUPPLIED IN SUCH A MANNER THAT THE PURCHASE ORDER HAVING OLDER DELIVERY SCHEDULE SHOULD BE SUPPLIED EARLIER AND PURCHASE ORDER HAVING LATTER DELIVERY SCHEDULE TO BE SUPPLIED LATTER. IF ANY VENDOR DOES NOT FOLLOW THE SEQUENTIAL DELIVERY SCHEDULE ESPECIALLY FOR SAME ITEM, BHEL MAY ACCOUNT FOR THE ITEM IN SEQUENTIAL MANNER OR MAY RECOVER THE FINANCIAL IMPLICATION.	
51	VENDOR MUST VISIT OUR WEBSITE <a href="https://herp.bhel.com">https://herp.bhel.com</a> REGULARLY FOR ENQUIRY/PO/CLARIFICATIONS/FOR ANY LATEST UPDATES.	
52	ALL ABOVE ACCEPTED TERMS & CONDITIONS SHALL BE PART OF PURCHASE ORDER WITH OR WITHOUT MENTIONING IN THE PO/CONTRACT BASED ON YOUR ACCEPTANCE AND OFFER SUBMITTED.	
53	FOREIGN VENDORS TO INDICATE THE CURRENCY LIKE EURO (€) / US\$ / GBP / JY ETC. IN THE CONFIRMATION COLUMN.	
54	<p><b>IMPORTANT INSTRUCTION:</b></p> <p>I.VENDORS ARE REQUESTED TO QUOTE THEIR RATE WITH DESCRIPTION MENTIONED IN THE ENQUIRY CONSIDERING ALL TECHNICAL TERMS &amp; CONDITIONS OF THE ENQUIRY. ALSO RATES QUOTED SHOULD BE EXACTLY AS PER SL. NO. OF HARD COPY OF THE ENQUIRY (IF ENQUIRY HAS BEEN FLOATED THROUGH CONVENTIONAL MODE) OR AS PER SL. NO. APPEARING IN THE e-Procurement PORTAL (IF ENQUIRY HAS BEEN FLOATED THROUGH e-Procurement) ONLY. IT MUST BE FOLLOWED UP TO AVOID CONFUSION AT LATER STAGES. ALSO RATES TO BE SUBMITTED BOTH IN NUMERICS AS WELL AS IN WORD. IN CASE OF DISCREPENCY, RATES SUBMITTED IN WORDS SHALL BE CONSIDERED FOR FURTHER PROCESSING.</p> <p>II.DOCUMENTS SUBMITTED WITH THE OFFER SHOULD BE SIGNED AND STAMPED IN EACH PAGE BY AUTHORIZED REPRESENTATIVE OF THE BIDDER.</p> <p>III.IN CASE OF PDI, VENDOR SHALL RAISE ONLINE INSPECTION CALL IN ONLINE INSPECTION PORTAL/INTIMATE BHEL IN WRITTING (WHERE INSPECTION IS IN BHEL HERP SCOPE) WELL IN ADVANCE OR AS MUTUALLY AGREED PERIOD ABOUT THE DATE AND PLACE AT WHICH GOODS WILL BE READY FOR INSPECTION.</p> <p>IV.PURCHASER OR HIS AUTHORIZED REPRESENTATIVE SHALL BE ENTITLED TO CARRY OUT SURVEILLANCE INSPECTION OF MATERIAL AND WORKMANSHIP AT SELLER'S PREMISES OR AT HIS SUB-CONTRACTOR'S PREMISES AT ALL REASONABLE TIMES DURING EXECUTION OF THE CONTRACT. SUCH INSPECTION, EXAMINATION AND TESTING, IF MADE, SHALL NOT ABSOLVE THE SELLER FROM HIS OBLIGATIONS UNDER THE CONTRACT.</p> <p>V.SUCH PRE-DISPATCH INSPECTION, EXAMINATION AND TESTING, IF MADE, AT VENDOR'S WORKS SHALL NOT ABSOLVE THE SELLER FROM HIS OBLIGATIONS TO MANUFACTURE/MACHINING THE GOODS UNDER THE CONTRACT. IF DEFECTS ARE FOUND AT LATER STAGE, IT IS THE SOLE RESPONSIBILITY OF THE VENDOR TO REPLACE/RECTIFY THE SAME.</p>	
55	<p><b>FOREIGN VENDORS MUST TAKE CARE WHILE BOOKING THE CONSIGNMENT ON CIF BASIS:</b></p> <p>I.THE INVOICES BEING ISSUED BY SHIPPING LINES MUST BE IN THE NAME OF BHARAT HEAVY ELECTRICLAS LIMITED, HEAVY EQUIPMENT REPAIR PLANT, VARANASI, UTTAR PRADESH, INDIA.</p> <p>II.WHILE BOOKING THE SHIPMENT, VENDOR SHOULD ALSO FINALIZE DESTINATION CHARGES AND THE SAME SHOULD BE CONVEYED TO BHARAT HEAVY ELECTRICLAS LIMITED – REGIONAL OPERATION DIVISION, MUMBAI OFFICE OR BHARAT HEAVY ELECTRICLAS LIMITED, HEAVY EQUIPMENT REPAIR PLANT, VARANASI BEFORE THE CONSIGNMENT REACHES THE DESTINATION PORT.</p> <p>III.IF CARGO IS STUFFED IN CONTAINER THEN THE SAME SHOULD BE ALLOWED TO BE MOVED TO CONTAINER FREIGHT STATIONS (CFS) OF IMPORTERS CHOICE WITHOUT ANY ADDITIONAL CHARGES.</p> <p>IV.LOAD PORT CHARGES SHOULD BE SETTLED BY THE VENDOR AND SHOULD NOT BE PASSED ON TO BHEL IN SOME FORM OF DESTINATION CHARGES.</p> <p>V.SUPPLIERS MUST PROVIDE 14 DAYS FREE DETENTION FROM THE DATE OF DELIVERY AT DELIVERY PORT. WHEREEVER DETENTION FREE PERIOD OFFERED IS LESS THAT 14 DAYS, THE BIDS SHALL BE LOADED FOR THE PERIOD SHORT OF 14 DAYS PERIOD. IF IT NOT MENTIONED AT OFFER STAGE, IT WOULD BE CONSIDERED AS 14 DAYS ONLY.</p> <p>VI. PORT CONGESTION CHARGES OR ANY ADDITIONAL CHARGES CLAIMED BY SHIPPING LINE TILL DELIVERY AT DESTINATION PORT SHALL BE TO THE SELLER'S ACCOUNT.</p> <p>VII. TRANSHIPMENT IS PROHIBITED.</p> <p>VIII. LOADING ON DECK NOT PERMITTED.</p> <p>IX. THE TRANSPORT DOCUMENT MUST BE ISSUED BY THE CARRIER OR HIS AGENT AND NOT BY ANY FREIGHT FORWARDER.</p> <p>X. THE BILLS OF EXCHANGE MUST BE DATED AND PRESENTATION OF DOCUMENTS FOR NEGOTIATION MUST NOT BE LATER THAN 21 DAYS AFTER THE DATE OF SHIPMENT / AIRFREIGHT AND IN ANY CASE NOT LATER THAN THE EXPIRY DATE OF THE CREDIT.</p>	
56	<p><b>TAXES AND DUTIES: -</b></p> <p><b>FOR INDIGENEOUS PURCHASES: -</b></p> <p>INPUT TAX CREDIT OF GST CAN BE AVAILED BY BHEL ONLY WHEN THE MATERIAL HAS BEEN PHYSICALLY RECEIVED AND GST INVOICE IS IN POSSESSION OF BHEL. THEREFORE, SUPPLIERS SHOULD ENSURE THE FOLLOWING IN RESPECT OF POS ISSUED BY BHEL:</p> <p>I. GST INVOICE SHOULD CONTAIN ADDRESS, GST NO. AND PAN NO. OF BHEL AS WELL AS OF SUPPLIER. APPLICABLE HSN CODE OF THE MATERIAL SHOULD BE INDICATED</p>	

**GENERAL COMMERCIAL TERMS & CONDITIONS OF ENQUIRY FOR CAPITAL ITEM PURCHASE  
(FOR INDIAN AS WELL AS FOREIGN VENDORS)**

ANNEXURE-Z

	<p>IN THE GST INVOICE.</p> <p>II. FIVE COPIES OF GST INVOICE AND LORRY RECEIPT MAY BE DESPATCHED ALONGWITH SHIPMENT OF THE GOODS IN ORDER TO AVOID ANY DELAY IN AVAILING INPUT CREDIT BY BHEL.</p> <p>III. DECLARE SUCH INVOICE IN HIS GSTR-1 RETURN FOR THE MONTH OF DESPATCH OF MATERIAL.</p> <p>IV. PAYMENT OF GST TO STATUTORY AUTHORITIES WITHIN PRESCRIBED TIME.</p> <p>IN CASE GST CREDIT IS DELAYED /DENIED TO BHEL DUE TO NON OR DELAYED RECEIPT OF GOODS AND OR TAX INVOICE OR EXPIRY OF TIMELINE PRESCRIBED IN GST LAW FOR AVAILING SUCH ITC OR ANY OTHER REASON NOT ATTRIBUTABLE TO BHEL, GST AMOUNT SHALL BE RECOVERABLE FROM VENDOR ALONG WITH INTEREST /PENALTY LEVIABLE ON BHEL.</p> <p>IN CASE SUPPLIERS DELAYS DECLARING SUCH INVOICE IN HIS RETURN AND GST CREDIT AVAILED BY BHEL IS DENIED OR REVERSED SUBSEQUENTLY AS PER GST LAW, GST AMOUNT PAID BY BHEL TOWARDS SUCH ITC REVERSAL SHALL BE RECOVERABLE FROM SUPPLIER ALONGWITH INTEREST LEVIED/LEVIABLE ON BHEL.</p> <p>IN CASE OF RAISING ANY SUPPLEMENTARY TAX INVOICE (DEBIT/ CREDIT NOTE), THE SUPPLIER SHALL ISSUE THE SAME CONTAINING ALL THE DETAILS AS REFERRED TO IN SECTION 34 READ WITH SECTION 31 OF GST ACT &amp; RULES REFERRED THERE UNDER.</p> <p>THE TAXES AS APPLICABLE SHALL BE QUOTED IN THE FOLLOWING MANNER</p> <table border="1" data-bbox="180 594 1385 663"> <tr> <td>IGST/CGST/SGST/UTGST: RATE OF TAX TO BE QUOTED AS EXTRA IN %</td> <td>:</td> <td></td> </tr> <tr> <td>VENDOR TO INDICATE HSN OF GOODS OR SAC OF SERVICES</td> <td>:</td> <td></td> </tr> <tr> <td colspan="3">ANY OTHER TAXES &amp; DUTIES NOT COVERED ANYWHERE ABOVE MAY BE INDICATED SEPARATELY:</td> </tr> </table> <p>TAXES PREVALENT ON THE CONTRACTUAL DELIVERY DATE OR THE ACTUAL DELIVERY DATE (INCASE OF DELAY) WHICH EVER IS LOWER SHALL BE APPLICABLE PAID. IN CASE BIDDER HAS OPTED FOR GST COMPOSITION SCHEME, THE SAME MAY BE STATED EXPLICITLY BOTH IN THEIR TECHNICAL AND PRICE BIDS.</p> <p><b>TAXES DEDUCTED AT SOURCE:</b></p> <p>TDS AS PER THE EXTANT STATUTE SHALL BE RECOVERED. IN CASE VENDOR DOES NOT PROVIDE PAN DETAILS/CONCESSIONAL CERTIFICATES, THE TDS DEDUCTION SHALL BE AT THE MAXIMUM PERCENTAGE STIPULATED AS PER THE PROVISIONS OF INCOME TAX ACT.</p> <p><b>GST TDS:</b> IS APPLICABLE AS PER LATEST GST ACT.</p> <p><b>FOREIGN PURCHASE (IMPORTS):</b></p> <p>THE OFFERED PRICE SHALL BE INCLUSIVE OF ALL THE TAXES AND DUTIES AS APPLICABLE IN COUNTRY OF BIDDER/COUNTRY OF DISPATCH FOR THE QUOTED CIF PRICE. ALL DUTIES (LIKE CUSTOMS DUTY ETC.) PAYABLE IN INDIA WILL BE PAID BY BHEL (HOWEVER, THE SAME WOULD BE LOADED TO THE OFFER DURING THE EVALUATION PROCESS. FOR THE SUPPLIES MADE FROM INDIA TAXES &amp; DUTIES PAYABLE SHALL BE CLEARLY MENTIONED IN THE OFFER, FAILING WHICH SUCH TAXES AND DUTIES SHALL HAVE TO BE BORNE BY THE VENDOR.</p> <p><b>TAXES DEDUCTED AT SOURCE:</b></p> <p>TDS AS PER THE EXTANT STATUTE SHALL BE RECOVERED. IN CASE VENDOR DOES NOT PROVIDE PAN DETAILS/CONCESSIONAL CERTIFICATES, THE TDS DEDUCTION SHALL BE AT THE MAXIMUM PERCENTAGE STIPULATED AS PER THE PROVISIONS OF INCOME TAX ACT.</p> <p>ANY SERVICE CHARGES PAYABLE TOWARDS SUPERVISION OF E&amp;C, TRAINING, PERFORMANCE PROVE-OUT ETC., WILL BE RELEASED AFTER DEDUCTION OF INCOME TAX AS PER INDIAN INCOME TAX ACT / AS PER THE GOVT. OF INDIA RULES AND TDS CERTIFICATE WILL BE ISSUED BY BHEL FOR SUCH DEDUCTIONS. THE TDS CERTIFICATE WILL BE ISSUED AFTER 3 MONTHS FROM THE DATE OF E&amp;C PAYMENT.</p> <p>GST ON E&amp;C PORTION WILL BE DISCHARGED BY BHEL ON RCM BASIS.</p>	IGST/CGST/SGST/UTGST: RATE OF TAX TO BE QUOTED AS EXTRA IN %	:		VENDOR TO INDICATE HSN OF GOODS OR SAC OF SERVICES	:		ANY OTHER TAXES & DUTIES NOT COVERED ANYWHERE ABOVE MAY BE INDICATED SEPARATELY:			
IGST/CGST/SGST/UTGST: RATE OF TAX TO BE QUOTED AS EXTRA IN %	:										
VENDOR TO INDICATE HSN OF GOODS OR SAC OF SERVICES	:										
ANY OTHER TAXES & DUTIES NOT COVERED ANYWHERE ABOVE MAY BE INDICATED SEPARATELY:											
57	<p><b>STATUTORY VARIATION CLAUSE:</b></p> <p>1.ANY INCREASE IN THE RATE OF GST SHALL BE PAYABLE ONLY FOR DELIVERIES COMPLETED WITHIN THE SCHEDULED DELIVERY PERIOD, IN OTHER WORDS INCREASE IN THE RATE OF GST SHALL NOT BE PAYABLE FOR VALUE OF CONSIGNMENT DELIVERED AFTER THE SCHEDULED PURCHASE ORDER DELIVERY PERIOD.</p> <p>2.NEW TAXES AND DUTIES, IF IMPOSED SUBSEQUENT TO DUE DATE OF OFFER SUBMISSION, BY STATUTORY AUTHORITY DURING CONTRACT PERIOD (INCLUDING EXTENSION IF THE SAME IS NOT ATTRIBUTABLE TO BIDDER) SHALL BE REIMBURSED BY BHEL ON PRODUCTION OF RELEVANT SUPPORTING DOCUMENTS TO THE SATISFACTION OF BHEL. HOWEVER, BIDDER SHALL TAKE PRIOR APPROVAL OF BHEL BEFORE DEPOSITING NEW TAXES AND DUTIES.</p> <p>3. IN CASE OF DECREASE IN ANY TAX OR OTHER ASPECTS, BENEFIT WILL BE PASSED ON TO BHEL.</p>										
58	<p><b>PURCHASE PREFERENCE FOR INDIAN VENDORS:</b> PURCHASE PREFERENCE FOR INDIAN VENDORS: FOR THIS PROCUREMENT, THE LOCAL CONTENT TO CATEGORIZE A SUPPLIER AS A CLASS I LOCAL SUPPLIER / CLASS II LOCAL SUPPLIER /NON LOCAL – SUPPLIER AND PURCHASE PREFERENCE TO CLASS I LOCAL SUPPLIER, IS AS DEFINED IN PUBLIC PROCUREMENT (PREFERENCE TO MAKE IN INDIA), ORDER 2017 DATED 04.06.2020 ISSUED BY DPIIT. IN CASE OF SUBSEQUENT ORDERS ISSUED BY THE NODAL MINISTRY, CHANGING THE DEFINITION OF LOCAL CONTENT FOR THE ITEMS OF THE NIT, THE SAME SHALL BE APPLICABLE EVEN IF ISSUED AFTER ISSUE OF THIS NIT, BUT BEFORE OPENING OF PART –II BIDS AGAINST THIS NIT.</p> <p><b>MODEL CLAUSE FOR TENDER.</b></p> <p>I. A BIDDER IS PERMITTED TO PROCURE RAW MATERIALS, COMPONENTS, SUB ASSEMBLIES ETC. FROM THE VENDORS FROM COUNTRIES WHICH SHARE A LAND BORDER WITH INDIA. SUCH VENDORS WILL NOT BE REQUIRED TO BE REGISTERED WITH THE COMPETENT AUTHORITY I.E. DPIIT.</p> <p>IN CASE A BIDDER HAS PROPOSED TO SUPPLY FINISHED GOODS DIRECTLY/ INDIRECTLY FROM VENDORS FROM THE COUNTRIES SHARING LAND BORDER WITH INDIA, SUCH VENDOR WILL BE REQUIRED TO BE REGISTERED WITH THE COMPETENT AUTHORITY.</p> <p>II. ANY BIDDER FROM A COUNTRY WHICH SHARES A LAND BORDER WITH INDIA WILL BE ELIGIBLE TO BID IN THIS TENDER ONLY IF THE BIDDER IS REGISTERED WITH THE COMPETENT AUTHORITY.</p> <p>III. "BIDDER" (INCLUDING THE TERM 'TENDERER', 'CONSULTANT' OR 'SERVICE PROVIDER' IN CERTAIN CONTEXTS) MEANS ANY PERSON OR FIRM OR COMPANY, INCLUDING ANY MEMBER OF A CONSORTIUM OR JOINT VENTURE (THAT IS AN ASSOCIATION OF SEVERAL PERSONS, OR FIRMS OR COMPANIES), EVERY ARTIFICIAL JURIDICAL PERSON NOT FALLING IN ANY OF THE DESCRIPTIONS OF BIDDERS STATED HEREINBEFORE, INCLUDING ANY AGENCY BRANCH OR OFFICE CONTROLLED BY SUCH PERSON, PARTICIPATING IN A PROCUREMENT PROCESS.</p>										

**GENERAL COMMERCIAL TERMS & CONDITIONS OF ENQUIRY FOR CAPITAL ITEM PURCHASE  
(FOR INDIAN AS WELL AS FOREIGN VENDORS)**

ANNEXURE-Z

	<p>IV. "BIDDER FROM A COUNTRY WHICH SHARES A LAND BORDER WITH INDIA" FOR THE PURPOSE OF THIS ORDER MEANS: -</p> <p>a) AN ENTITY INCORPORATED, ESTABLISHED OR REGISTERED IN SUCH A COUNTRY: OR</p> <p>b) A SUBSIDIARY OF AN ENTITY INCORPORATED, ESTABLISHED OR REGISTERED IN SUCH A COUNTRY; OR</p> <p>c) AN ENTITY SUBSTANTIALLY CONTROLLED THROUGH ENTITIES INCORPORATED, ESTABLISHED OR REGISTERED IN SUCH A COUNTRY; OR</p> <p>d) AN ENTITY WHOSE BENEFICIAL OWNER IS SITUATED IN SUCH A COUNTRY; OR</p> <p>e) AN INDIAN (OR OTHER) AGENT OF SUCH AN ENTITY; OR</p> <p>f) A NATURAL PERSON WHO IS A CITIZEN OF SUCH A COUNTRY; OR</p> <p>g) A CONSORTIUM OR JOINT VENTURE WHERE ANY MEMBER OF THE CONSORTIUM OR JOINT VENTURE FALLS UNDER ANY OF THE ABOVE</p> <p>V. THE BENEFICIAL OWNER FOR THE PURPOSE OF (III) ABOVE WILL BE AS UNDER:</p> <p>1. IN CASE OF A COMPANY OR LIMITED LIABILITY PARTNERSHIP, THE BENEFICIAL OWNER IS THE NATURAL PERSON (S) WHO, WHETHER ACTING ALONE OR TOGETHER, OR THROUGH ONE OR MORE JURIDICAL PERSON, HAS A CONTROLLING OWNERSHIP INTEREST OR WHO EXERCISES CONTROL THROUGH OTHER MEANS.</p> <p>EXPLANATION –</p> <p>a. "CONTROLLING OWNERSHIP INTEREST" MEANS OWNERSHIP OF OR ENTITLEMENT TO MORE THAN TWENTY-FIVE PER CENT. OF SHARES OR CAPITAL OR PROFITS OF THE COMPANY</p> <p>b. "CONTROL" SHALL INCLUDE THE RIGHT TO APPOINT MAJORITY OF THE DIRECTORS OR TO CONTROL THE MANAGEMENT OR POLICY DECISIONS INCLUDING BY VIRTUE OF THEIR SHAREHOLDING OR MANAGEMENT RIGHTS OR SHAREHOLDER'S AGREEMENTS OF VOTING AGREEMENTS;</p> <p>2. IN CASE OF A PARTNERSHIP FIRM, THE BENEFICIAL OWNER IS THE NATURAL PERSON (S) WHO, WHETHER ACTING ALONE OR TOGETHER, OR THROUGH ONE OR MORE JURIDICAL OF CAPITAL OR PROFITS OF THE PARTNERSHIP;</p> <p>3. IN CASE OF AN UNINCORPORATED ASSOCIATION OR BODY OF INDIVIDUALS, THE BENEFICIAL OWNER IS THE NATURAL PERSON (S), WHO, WHETHER ACTING ALONE OR TOGETHER, OR THROUGH ONE OR MORE JURIDICAL PERSON, HAS OWNERSHIP OF OR ENTITLEMENT TO MORE THAN FIFTEEN PERCENT OF THE PROPERTY OF CAPITAL OF PROFITS OF SUCH ASSOCIATION OR BODY OF INDIVIDUALS;</p> <p>4. WHERE NO NATURAL PERSON IS IDENTIFIED UNDER (1) OR (2) OR (3) ABOVE, THE BENEFICIAL OWNER IS THE RELEVANT NATURAL PERSON WHO HOLDS THE POSITION OF SENIOR MANAGING OFFICIAL;</p> <p>5. IN CASE OF TRUST, THE IDENTIFICATION OF BENEFICIAL OWNER (S) SHALL INCLUDE IDENTIFICATION OF THE AUTHOR OF THE TRUST, THE TRUSTEE, THE BENEFICIARIES WITH FIFTEEN PERCENT OR MORE INTEREST IN THE TRUST AND ANY OTHER NATURAL PERSON EXERCISING ULTIMATE EFFECTIVE CONTROL OVER THE TRUST THROUGH A CHAIN OF CONTROL OR OWNERSHIP.</p> <p>VI. AN AGENT IS A PERSON EMPLOYED TO DO ANY ACT FOR ANOTHER, OR TO REPRESENT ANOTHER IN DEALINGS WITH THIRD PERSON.</p> <p><b>CERTIFICATE:</b> IN ORDER TO AVAIL THE BENEFITS, VENDORS TO SUBMIT (ALONG WITH OFFER) THE SELF-CERTIFICATION THAT THE ITEM OFFERED MEETS THE CONTENT REQUIREMENT FOR CLASS-I/ CLASS-II LOCAL SUPPLIER AS THE CASE MAY BE, INDICATING THE PERCENTAGE OF LOCAL CONTENT. AND SHALL GIVE DETAILS OF LOCATION AT WHICH THE LOCAL VALUE ADDITION IS MADE (refer attached Make in India (Model Certificate no I).</p>	
59	<p><b>IMPORTANT INSTRUCTION FOR MSEs SUPPLIERS:</b></p> <p>I. "MSE SUPPLIERS CAN AVAIL THE INTENDED BENEFITS ONLY IF THEY SUBMIT ALONG WITH OFFER, ATTESTED COPIES OF EITHER EM-II CERTIFICATE HAVING DEEMED VALIDITY (FIVE YEARS FROM THE DATE OF ISSUE OF ACKNOWLEDGEMENT IN EM-II) OR VALID NSIC CERTIFICATE OR EM-II CERTIFICATE ALONG WITH CA CERTIFICATE (FORMAT ENCLOSED AS PER ANNEXURE-1 WHERE DEEMED VALIDITY OF EM-II CERTIFICATE OF FIVE YEARS HAS EXPIRED) APPLICABLE FOR THE RELEVANT F/Y (LATEST AUDITED).DATE TO BE RECKONED FOR DETERMINING THE DEEMED VALIDITY WILL BE THE DATE OF BID OPENING (PART -1 IN CASE OF TWO PART BID). NON SUBMISSION OF SUCH DOCUMENTS WILL LEAD TO CONSIDERATION OF THEIR BID AT PAR WITH OTHER BIDDERS. NO BENEFIT SHALL BE APPLICABLE FOR THIS ENQUIRY IF ANY DEFICIENCY IN THE ABOVE REQUIRED DOCUMENTS ARE NOT SUBMITTED BEFORE PRICE BID OPENING. IF THE TENDER IS TO BE SUBMITTED THROUGH e-procurement PORTAL, THEN THE ABOVE REQUIRED DOCUMENTS ARE TO BE UPLOADED ON THE PORTAL. DOCUMENTS SHOULD BE NOTARIZED OR ATTESTED BY A GAZETTED OFFICE.</p> <p>II. IN CASE OF ANY CHANGE IN THE MSE STATUS OF THE BIDDER, IT SHALL BE RESPONSIBILITY OF THE BIDDER TO NOTIFY THE CHANGE AS A PART OF THE BID DOCUMENT. IF AT A LATER DATE IT COMES TO NOTICE OF BHEL, THAT THE CHANGE IN THE STATUS HAS NOT BEEN INTIMATED BY THE BIDDER AND THE ORDER IS OBTAINED UNDER THE PREMISE OF AN MSE, THEN BHEL WOULD CANCEL THE PENDING ORDER AGAINST THIS TENDER AND TAKE NECESSARY ACTION SUSPENSION OF THE BUSSINESS DEALING WITH THE BIDDER AS PER PROCUREMENT POLICY OF BHEL.</p> <p>III. IN CASE AFTER OPENING OF PRICE BID, IT IS SEEN THAT NO MSE HAS BECOME L1, THEN DEPENDING ON THE NATURE OF THE ITEM, IF IT IS NOT POSSIBLE TO SPLIT THE TENDERED ITEMS/QUANTITIES ON ACCOUNT OF REASONS LIKE CUSTOMER CONTRACT REQUIREMENTS OF SUPPLYING ONE MAKE FOR A GIVEN PROJECT OR TECHNICAL REASONS LIKE TENDERED ITEMS BEING A SYSTEM etc. THEN BHEL WOULD NOT COUNTER OFFER THE L1 PRICES EVEN THOUGH THERE MAY BE MSE BIDDERS WITHIN THE "L1+15% PRICE BAND" OF L1.</p>	
60	<p><b>FORCE MAJEURE :</b> NOTWITHSTANDING ANYTHING CONTAINED IN THE CONTRACT, NEITHER THE VENDOR NOR THE BHEL SHALL BE HELD RESPONSIBLE FOR TOTAL OR PARTIAL NON-EXECUTION OF ANY OF THE CONTRACTUAL OBLIGATIONS, SHOULD THE OBLIGATION BECOME UNREASONABLY ONEROUS OR IMPOSSIBLE DUE TO OCCURRENCE OF A 'FORCE MAJEURE' WHICH DIRECTLY AFFECTS THE OBLIGATIONS TO BE PERFORMED BY THE BHEL OR THE VENDOR ; SUCH EVENTS INCLUDE WAR, MILITARY OPERATIONS OF ANY NATURE, BLOCKAGES, REVOLUTIONS, INSURRECTIONS, RIOTS, CIVIL COMMOTIONS, INSURGENCY, SABOTAGE, ACTS OF PUBLIC ENEMY, FIRES, EXPLOSION, EPIDEMICS, QUARANTINE RESTRICTIONS, FLOODS, EARTHQUAKE, OR ACTS OF GOD, RESTRICTIONS BY GOVT. AUTHORITIES; OVER WHICH THE VENDOR OR THE BHEL HAS NO CONTROL. THE PARTY CLAIMING TO BE AFFECTED BY FORCE MAJEURE SHALL NOTIFY THE OTHER PARTY IN WRITING WITHOUT DELAY, WITHIN TWO WEEKS ON THE INTERVENTION AND ON THE CESSATION OF SUCH CIRCUMSTANCE. EXTENSION OF TIME SOUGHT BY THE VENDOR ALONG WITH SUPPORTING EVIDENCE AND SO GRANTED BY THE BHEL FOR THE SUPPLY/ WORK AFFECTED, IF ANY, SHALL NOT BE CONSTRUED AS WAIVER IN RESPECT OF REMAINING DELIVERIES. RESCHEDULING OF DELIVERIES ON ACCOUNT OF FORCE MAJEURE CONDITIONS, IF SO AGREED BY THE BHEL, WILL NOT ENTAIL THE VENDOR TO CLAIM ANY INCREASE IN THE PRICE ON WHATSOEVER ACCOUNT. NOTWITHSTANDING ABOVE PROVISIONS, BHEL SHALL RESERVE THE RIGHT TO CANCEL THE ORDER/ CONTRACT, WHOLLY OR PARTLY, IN ORDER TO MEET THE OVERALL PROJECT SCHEDULE AND MAKE ALTERNATIVE ARRANGEMENTS. IF DEEMED NECESSARY, BHEL MAY TAKEOVER PARTLY PROCESSED MATERIAL AT A MUTUALLY AGREED PRICE.</p>	
61	<p><b>FRAUD PREVENTION POLICY :</b> THE BIDDER ALONG WITH ITS ASSOCIATE/ COLLABORATORS/ SUB-CONTRACTORS/ SUB-VENDORS/ CONSULTANTS/ SERVICE PROVIDERS SHALL STRICTLY ADHERE TO BHEL FRAUD PREVENTION POLICY DISPLAYED ON BHEL WEBSITE <a href="http://WWW.BHEL.COM">WWW.BHEL.COM</a> AND SHALL IMMEDIATELY BRING TO THE NOTICE OF BHEL MANAGEMENT ABOUT ANY FRAUD OR SUSPECTED FRAUD AS SOON AS IT COMES TO THEIR NOTICE.</p>	
62	<p><b>SHORT SHIPMENTS/ WARRANTY/GUARANTEE REPLACEMENTS:</b> IN CASE OF ANY SHORT SHIPMENT DURING INITIAL SUPPLY WHICH IS SUBSEQUENTLY DISPATCHED BY THE VENDOR OR ANY GUARANTEE / WARRANTY REPLACEMENTS SHALL BE DISPATCHED ON " "FOR-BHEL STORES/DESIGNATED DESTINATION" BASIS FOR INDIGENOUS ITEMS. TAXES, IF ANY PAID BY INDIGENOUS VENDOR FOR GUARANTEE /WARRANTEE REPLACEMENT, REPAIR ACTIVITY EXCLUDING SHORT SUPPLY SHALL BE TO VENDOR'S ACCOUNT ONLY. THE VENDOR HAS TO RAISE A CREDIT NOTE FOR SHORT SUPPLIED QUANTITY AS PER GST PROVISIONS.</p> <p><b>FOR FOREIGN SUPPLIES: -</b></p> <p>IN CASE, ANY SHORTAGE IS NOTICED VIZ-VIZ PO REQUIREMENT IN THE MAIN EQUIPMENT/SPARES,SUCH SHORTAGE SHALL BE REPLENISHED BY SUPPLIER ON FOR DESTINATION BASIS (DDP- INCOMTERMS-2010 BASIS) WITHOUT ANY COST IMPLICATION TO BHEL I.E. CUSTOM DUTY AND FREIGHT CHARGES ETC.UPTO DESTINATION FOR SUCH SHORT SUPPLIES SHALL BE BORNE BY THE SUPPLIER. PLEASE ALSO NOTE THAT ANY SHORT SUPPLY WILL ATTRACT IMPOSITION OF PENALTY ON THE TOTAL P.O. VALUE.(SUPPLY+INSTALLATION).</p>	
63	<p><b>E WAY BILL:</b> THE SUPPLIER HAS TO ARRANGE FOR E WAY BILL AS APPLICABLE FOR ANY MOVEMENT OF GOODS ALONG WITH OTHER PRESCRIBED DOCUMENTS AS PER GST LAW. THE SUPPLIER HAS ALSO TO COMPLY WITH ANY AMENDMENT AS PRESCRIBED FROM TIME TO TIME UNDER E WAY BILL RULE. ANY FINANCIAL IMPLICATION ARISES ON BHEL DUE TO NONCOMPLIANCE OF E WAY BILL RULE WILL BE PASSED ON TO THE SUPPLIER.</p>	
64	<p><b>PRICE VARIATION CLAUSE (PVC): NO PVC IS APPLICABLE FOR THIS TENDER.</b></p> <p>PRICES ONCE QUOTED SHALL REMAIN FIRM WITHIN THE VALIDITY OR ANY EXTENSION THEREOF FOR PLACEMENT OF ORDER, TILL COMPLETE EXECUTION OF THE ORDER, WITHOUT ANY ESCALATION/INCREASE FOR ANY REASON, WHATSOEVER.</p>	

**GENERAL COMMERCIAL TERMS & CONDITIONS OF ENQUIRY FOR CAPITAL ITEM PURCHASE  
(FOR INDIAN AS WELL AS FOREIGN VENDORS)**

ANNEXURE-Z

	<b>OVER RUN COST (ORC) CLAUSE: NOT APPLICABLE.</b>	
65	THE VENDOR SHOULD PROVIDE BILLS & OTHER DOCUMENTS COMPLETE IN ALL RESPECT AS PER PURCHASE ORDER ALONGWITH DESPATCH OF MATERIALS. FURTHER, BHEL SHALL SEEK CLARIFICATION(S) (IF ANY) RELATED TO PAYMENT DOCUMENTS IN ONE GO. THE VENDOR SHOULD PROVIDE ALL SUCH CLARIFICATION(S) IMMEDIATELY. ANY DELAY IN PROCESSING OF PAYMENT, DUE TO NON RECEIPT OF CLARIFICATION(S) SOUGHT BY BHEL, SHALL BE ATTRIBUTABLE COMPLETELY TO VENDOR.	
66	THE STARTUPS AS DEFINED IN THE GAZETTE OF INDIA NOTIFICATION NO.: G.S.R. 127 (E) DATED 19/02/2019 WILL BE EXEMPTED FROM FULFILLING THE CRITERIA, IF MENTIONED, IN THE PQR (PRE-QUALIFYING REQUIREMENT) REGARDING PRIOR TURNOVER AND PRIOR EXPERIENCE. HOWEVER, THERE MAY BE CIRCUMSTANCES (LIKE PROCUREMENTS OF ITEMS RELATED TO PUBLIC SAFETY, HEALTH, CRITICAL SECURITY OPERATIONS AND EQUIPMENTS ETC.) WHERE BHEL MAY PREFER THE VENDORS TO HAVE PRIOR EXPERIENCE RATHER THAN GIVING ORDER TO NEW ENTITIES. FOR SUCH PROCUREMENTS, BHEL MAY NOT RELAX THE CRITERIA OF PRIOR EXPERIENCE/TURNOVER FOR THE STARTUPS.  FOR THIS CRITICAL MACHINE, OFFERS OF ALL THE BIDDERS INCLUDING MSEs AND START UPS WILL BE SCRUTINIZED AS PER PQR. NO RELAXATION WILL BE GIVEN FOR PRIOR TURNOVER AND PRIOR EXPERIENCE.	
67	THE BIDDER DECLARES THAT THEY WILL NOT ENTER INTO ANY ILLEGAL OR UNDISCLOSED AGREEMENT OR UNDERSTANDING, WHETHER FORMAL OR INFORMAL WITH OTHER BIDDER (S). THIS APPLIES IN PARTICULAR TO PRICES, SPECIFICATIONS, CERTIFICATIONS, SUBSIDIARY CONTRACTS, SUBMISSION OR NON- SUBMISSION OF BIDS OR ANY OTHER ACTIONS TO RESTRICT COMPETITIVENESS OR TO INTRODUCE CARTELIZATION IN THE BIDDING PROCESS. IN CASE, THE BIDDER IS FOUND HAVING INDULGED IN ABOVE ACTIVITIES, SUITABLE ACTION SHALL BE TAKEN BY BHEL AS PER EXISTANT POLICIES / GUIDELINES.	
68	<b>POST-ORDER REQUISITES:</b>  (A) VENDOR SHALL GIVE AN ORDER ACKNOWLEDGEMENT INDICATING THE DELIVERY DATE AND ACCEPTANCE OF PO TERMS AND CONDITIONS WITHIN ONE WEEK OF RECEIPT OF PO. (B) PRE-SHIPMENT INSPECTION AT VENDOR'S WORKS, IF REQUIRED, WILL BE CARRIED OUT BY BHEL. REQUIRED ASSISTANCE WILL HAVE TO BE PROVIDED BY THE VENDOR AT THE TIME OF PRESHIPMENT INSPECTION. (C) TEST CERTIFICATES, CALIBRATION CERTIFICATES AND WARRANTY CERTIFICATES AS STIPULATED AT THE TIME OF ORDERING SHALL BE FURNISHED ALONG WITH INSPECTION CALL LETTER. (D) ITEMS SHALL BE DISPATCHED BY AIR/ROAD/RAIL/SEA WORTHY PACKING. ANY DAMAGE AND LATER REJECTION, DUE TO POOR / IMPROPER PACKING SHALL BE TO VENDOR'S ACCOUNT. (E) ANY DAMAGE/REJECTION SHOULD BE MADE GOOD OR REPLACED IMMEDIATELY WITHOUT ANY EXTRA COST TO BHEL SUCH AS FREIGHT, DUTIES, TAXES ETC. THE LIABILITY IS RESTRICTED TO THE VALUE OF THE ORDER. (F) WHEREVER COMMISSIONING IS INVOLVED, IT SHALL BE CARRIED OUT BY THE VENDOR'S QUALIFIED ENGINEERS. SCOPE OF WORK INCLUDES INSTALLATION, COMMISSIONING AND START-UP TRIALS TILL SATISFACTORY PERFORMANCE LEVEL IS REACHED AS CERTIFIED BY BHEL. (G) BHEL WILL NOT BE RESPONSIBLE FOR ANY LOSS, DAMAGE OR INJURIES TO VENDOR'S PERSONNEL SUSTAINED DURING INSTALLATION / COMMISSIONING / START-UP TRIALS. VENDOR SHALL ENSURE COMPLIANCE WITH ALL STATUTORY REQUISITES AS LAID DOWN BY LOCAL BODIES, STATE & CENTRAL GOVERNMENT. VENDOR SHALL INDEMNIFY BHEL FOR ALL DAMAGES/ LOSSES TO VARIOUS PERSONNEL DURING THEIR PRESENCE IN BHEL'S PREMISES FOR WHATEVER PURPOSE. THE FOLLOWING SHALL BE ENSURED BY THE VENDOR: a) VENDOR/CONTRACTOR SHALL ENSURE THAT THE VENDOR/CONTRACTOR'S WORKMEN ALWAYS FOLLOW SAFE WORK PROCEDURE DURING ERECTING/ COMMISSIONING ACTIVITIES. b) VENDOR/CONTRACTOR SHALL ENSURE THAT THE VENDOR/CONTRACTOR'S WORKMEN WEAR SAFETY PPEs (SHOES, HELMETS, SAFETY BELT ETC.) WHILE ON ERECTING/ COMMISSIONING WORK AND SIMILAR WORKS. c) VENDOR/CONTRACTOR SHALL ENSURE ADEQUATE SUPERVISION OF THE ACTIVITY BY HIS/HER SUPERVISOR/ENGINEER DURING THE ERECTING/ COMMISSIONING ACTIVITIES.	
<b>TECHNICAL TERMS:-</b>		
69	A. PRE-QUALIFYING CRITERIA: -  THE TECHNICAL BID OF ONLY THOSE BIDDERS SHALL BE PROCESSED WHO MEET THE PREQUALIFYING REQUIREMENT AS PER ANNEXURE-B.  B. SUPPLY CONDITION: -  1. MATERIAL TO BE SUPPLIED AT BHEL STORES. 2. JOB PROVE OUT REQUIREMENT: REFER CLAUSE 6 OF ANNEXURE-A. 3. PRE DISPATCH INSPECTION: -AS PER CLAUSE 7 & 11 OF THE ANNEXURE-A. 4. TECHNICAL SPECIFICATION CUM COMPLIANCE CERTIFICATION FOR CENTRIFUGAL CASTING MACHINE 2500 Kgs CAPACITY AS PER ANNEXURE-A  C. DELIVERY, INSTALLATION & COMMISSIONING PERIOD, WARRANTY:  DELIVERY, INSTALLATION & COMMISSIONING PERIOD, WARRANTY SHALL BE AS PER CLAUSE 16 OF ANNEXURE-A. HOWEVER EARLY DELIVERY CLAUSE IS ACCEPTABLE.  D. CIVIL WORK FOR FOUNDATION SHALL BE IN SCOPE OF BHEL. VENDOR SHOULD SUBMIT DETAILS AS PER CLAUSE 8 OF ANNEXURE-A.  E. THE MINIMUM PERCENTAGE OF E&C VALUE IS 7.5%.	

NOTE:

- FOR FOREIGN SUPPLIERS: **CLAUSE NO. 13, 59 & 66** ARE NOT APPLICABLE FOR 'FOREIGN SUPPLIERS'. IT IS APPLICABLE FOR ONLY INDIAN SUPPLIERS.
- PLEASE FILL IN THIS FORMAT AND SEND COMPULSORILY ALONG WITH QUOTATION WITH VENDOR'S SEAL, SIGNATURE AND DATE.

**SIGNATURE ALONG WITH SEAL AND DATE:**

**GENERAL COMMERCIAL TERMS & CONDITIONS OF ENQUIRY FOR CAPITAL ITEM PURCHASE**  
**(FOR INDIAN AS WELL AS FOREIGN VENDORS)**

ANNEXURE-Z

**INTEGRITY PACT****Between**

Bharat Heavy Electricals Ltd. (BHEL), a company registered under the Companies Act 1956 and having its registered office at "BHEL House", Siri Fort, New Delhi - 110049 (India) hereinafter referred to as "The Principal", which expression unless repugnant to the context or meaning hereof shall include its successors or assigns of the ONE PART

**and**

\_\_\_\_\_, (description of the party along with address), hereinafter referred to as "The Bidder/ Contractor" which expression unless repugnant to the context or meaning hereof shall include its successors or assigns of the OTHER PART

**Preamble**

The Principal intends to award, under laid-down organizational procedures, contract/s for SUPPLY, INSTALLATION & COMMISSIONING OF CENTRIFUGAL CASTING MACHINE AS PER ANNEXURE-A AGAINST ENQUIRY NO E-588-22-0007-69-1 DTD 20.09.2022 (hereinafter referred to as "Contract"). The Principal values full compliance with all relevant laws of the land, rules and regulations, and the principles of economic use of resources, and of fairness and transparency in its relations with its Bidder(s)/ Contractor(s).

In order to achieve these goals, the Principal will appoint panel of Independent External Monitor(s) (IEMs), who will monitor the tender process and the execution of the contract for compliance with the principles mentioned above.

**Section 1- Commitments of the Principal**

1.1 The Principal commits itself to take all measures necessary to prevent corruption and to observe the following principles: -

1.1.1 No employee of the Principal, personally or through family members, will in connection with the tender for, or the execution of a contract, demand, take a promise for or accept, for self or third person, any material or immaterial benefit which the person is not legally entitled to.

1.1.2 The Principal will, during the tender process treat all Bidder(s) with equity and reason. The Principal will in particular, before and during the tender process, provide to all Bidder(s) the same information and will not provide to any Bidder(s) confidential/ additional information through which the Bidder(s) could obtain an advantage in relation to the tender process or the contract execution.

1.1.3 The Principal will exclude from the process all known prejudiced persons.

1.2 If the Principal obtains information on the conduct of any of its employees which is a penal offence under the Indian Penal Code 1860 and Prevention of Corruption Act 1988 or any other statutory penal enactment, or if there be a substantive suspicion in this regard, the Principal will inform its Vigilance Office and in addition can initiate disciplinary actions.

**Section 2 - Commitments of the Bidder(s)/ Contractor(s)**

2.1 The Bidder(s)/ Contractor(s) commit himself to take all measures necessary to prevent corruption. The Bidder(s)/ Contractor(s) commits himself to observe the following principles during participation in the tender process and during the contract execution.

- 2.1.1 The Bidder(s)/ Contractor(s) will not, directly or through any other person or firm, offer, promise or give to the Principal or to any of the Principal's employees involved in the tender process or the execution of the contract or to any third person any material, immaterial or any other benefit which he/ she is not legally entitled to, in order to obtain in exchange any advantage of any kind whatsoever during the tender process or during the execution of the contract.
- 2.1.2 The Bidder(s)/ Contractor(s) will not enter with other Bidder(s) into any illegal or undisclosed agreement or understanding, whether formal or informal. This applies in particular to prices, specifications, certifications, subsidiary contracts, submission or non-submission of bids or any other actions to restrict competitiveness or to introduce cartelization in the bidding process.
- 2.1.3 The Bidder(s)/ Contractor(s) will not commit any penal offence under the relevant Indian Penal Code (IPC) and Prevention of Corruption Act; further the Bidder(s)/ Contractor(s) will not use improperly, for purposes of competition or personal gain, or pass on to others, any information or document provided by the Principal as part of the business relationship, regarding plans, technical proposals and business details, including information contained or transmitted electronically.
- 2.1.4 Foreign Bidder(s)/ Contractor(s) shall disclose the name and address of agents and representatives in India and Indian Bidder(s)/ Contractor(s) to disclose their foreign principals or associates. The Bidder(s)/ Contractor(s) will, when presenting his bid, disclose any and all payments he has made, and is committed to or intends to make to agents, brokers or any other intermediaries in connection with the award of the contract.
- 2.2 The Bidder(s)/ Contractor(s) will not instigate third persons to commit offences outlined above or be an accessory to such offences.
- 2.3 The Bidder(s)/ Contractor(s) shall not approach the Courts while representing the matters to IEMs and shall await their decision in the matter.

### **Section 3 - Disqualification from tender process and exclusion from future contracts**

If the Bidder(s)/ Contractor(s), before award or during execution has committed a transgression through a violation of Section 2 above, or acts in any other manner such as to put his reliability or credibility in question, the Principal is entitled to disqualify the Bidder(s)/ Contractor(s) from the tender process, terminate the contract, if already awarded, exclude from future business dealings and/ or take action as per the separate "Guidelines on Banning of Business dealings with Suppliers/ Contractors", framed by the Principal.

### **Section 4 - Compensation for Damages**

- 4.1 If the Principal has disqualified the Bidder (s) from the tender process before award / order acceptance according to Section 3, the Principal is entitled to demand and recover the damages equivalent to Earnest Money Deposit/ Bid Security.
- 4.2 If the Principal is entitled to terminate the Contract according to Section 3, or terminates the Contract in application of Section 3 above, the Bidder(s)/ Contractor (s) transgression through a violation of Section 2 above shall be construed breach of contract and the Principal shall be entitled to demand and recover from the Contractor an amount equal to 5% of the contract value or the amount equivalent to Security Deposit/ Performance Bank Guarantee, whichever is higher, as damages, in

addition to and without prejudice to its right to demand and recover compensation for any other loss or damages specified elsewhere in the contract.

#### **Section 5 - Previous Transgression**

5.1 The Bidder declares that no previous transgressions occurred in the last 3 (three) years with any other company in any country conforming to the anti-corruption approach or with any other Public Sector Enterprise in India that could justify his exclusion from the tender process.

5.2 If the Bidder makes incorrect statement on this subject, he can be disqualified from the tender process or the contract, if already awarded, can be terminated for such reason or action can be taken as per the separate "Guidelines on Banning of Business dealings with Suppliers/ Contractors", framed by the Principal.

#### **Section 6 - Equal treatment of all Bidder (s)/ Contractor (s) / Sub-contractor (s)**

6.1 The Principal will enter into Integrity Pacts with identical conditions as this Integrity Pact with all Bidders and Contractors.

6.2 In case of Sub-contracting, the Principal Contractor shall take the responsibility of the adoption of Integrity Pact by the Sub-contractor(s) and ensure that all Sub-contractors also sign the Integrity Pact.

6.3 The Principal will disqualify from the tender process all Bidders who do not sign this Integrity Pact or violate its provisions.

#### **Section 7 - Criminal Charges against violating Bidders/ Contractors /Subcontractors**

If the Principal obtains knowledge of conduct of a Bidder, Contractor or Subcontractor, or of an employee or a representative or an associate of a Bidder, Contractor or Subcontractor which constitutes corruption, or if the Principal has substantive suspicion in this regard, the Principal will inform the Vigilance Office.

#### **Section 8 -Independent External Monitor(s)**

8.1 The Principal appoints competent and credible panel of Independent External Monitor (s) (IEMs) for this Integrity Pact. The task of the IEMs is to review independently and objectively, whether and to what extent the parties comply with the obligations under this Integrity Pact.

8.2 The IEMs are not subject to instructions by the representatives of the parties and performs his functions neutrally and independently. He reports to the CMD, BHEL.

8.3 The IEMs shall be provided access to all documents/ records pertaining to the Contract, for which a complaint or issue is raised before them as and when warranted. However, the documents/records/information having National Security implications and those documents which have been classified as Secret/Top Secret are not to be disclosed.

8.4 The Principal will provide to the IEMs sufficient information about all meetings among the parties related to the Contract provided such meetings could have an impact on the contractual relations between the Principal and the Contractor. The parties offer to the IEMs the option to participate in such meetings.

- 8.5 The advisory role of IEMs is envisaged as that of a friend, philosopher and guide. The advice of IEMs would not be legally binding and it is restricted to resolving issues raised by a Bidder regarding any aspect of the tender which allegedly restricts competition or bias towards some Bidders. At the same time, it must be understood that IEMs are not consultants to the Management. Their role is independent in nature and the advice once tendered would not be subject to review at the request of the organization.
- 8.6 For ensuring the desired transparency and objectivity in dealing with the complaints arising out of any tendering process or during execution of Contract, the matter should be examined by the full panel of IEMs jointly, who would look into the records, conduct an investigation, and submit their joint recommendations to the Management.
- 8.7 The IEMs would examine all complaints received by them and give their recommendations/ views to the CMD, BHEL at the earliest. They may also send their report directly to the CVO, in case of suspicion of serious irregularities requiring legal/ administrative action. Only in case of very serious issue having a specific, verifiable Vigilance angle, the matter should be reported directly to the Commission. IEMs will tender their advice on the complaints within 30 days.
- 8.8 The CMD, BHEL shall decide the compensation to be paid to the IEMs and its terms and conditions.
- 8.9 IEMs should examine the process integrity, they are not expected to concern themselves with fixing of responsibility of officers. Complaints alleging mala fide on the part of any officer of the Principal should be looked into by the CVO of the Principal.
- 8.10 If the IEMs have reported to the CMD, BHEL, a substantiated suspicion of an offence under relevant Indian Penal Code / Prevention of Corruption Act, and the CMD, BHEL has not, within reasonable time, taken visible action to proceed against such offence or reported it to the Vigilance Office, the IEMs may also transmit this information directly to the Central Vigilance Commissioner, Government of India.
- 8.11 After award of work, the IEMs shall look into any issue relating to execution of Contract, if specifically raised before them. As an illustrative example, if a Contractor who has been awarded the Contract, during the execution of Contract, raises issue of delayed payment etc. before the IEMs, the same shall be examined by the panel of IEMs. Issues like warranty/ guarantee etc. shall be outside the purview of IEMs.
- 8.12 However, the IEMs may suggest systemic improvements to the management of the Principal, if considered necessary, to bring about transparency, equity and fairness in the system of procurement.
- 8.13 The word 'Monitor' would include both singular and plural.

## **Section 9 - Pact Duration**

- 9.1 This Integrity Pact shall be operative from the date this Integrity Pact is signed by both the parties till the final completion of contract for successful Bidder, and for all other Bidders 6 months after the Contract has been awarded. Any violation of the same would entail disqualification of the bidders and exclusion from future business dealings.
- 9.2 If any claim is made/ lodged during currency of this Integrity Pact, the same shall be binding and continue to be valid despite the lapse of this Pact as specified above, unless it is discharged/ determined by the CMD, BHEL.



**PROFORMA OF BANK GUARANTEE (in lieu of SECURITY DEPOSIT)**

In consideration of Bharat Heavy Electricals Limited (hereinafter referred to as the 'Employer' which expression shall unless repugnant to the context or meaning thereof, include its successors and permitted assigns) incorporated under the Companies Act, 1956 and having its registered office at \_\_\_\_\_<sup>1</sup> through its Unit at \_\_\_\_\_ (name of the Unit) having agreed to exempt (Name of the Vendor / Contractor / Vendors) with its registered office at \_\_\_\_\_<sup>2</sup> (hereinafter called the said 'Contractor' which term includes vendors), from demand under the terms and conditions of the Contract reference No. \_\_\_\_\_ dated \_\_\_\_\_<sup>3</sup> valued at Rs \_\_\_\_\_<sup>4</sup> ( Rupees -----)<sup>4</sup> (hereinafter called the said Contract), of Security Deposit for the due fulfilment by the said Contractor of the terms and conditions contained in the said Contract, on production of a Bank Guarantee for Rs. \_\_\_\_\_<sup>5</sup> (Rupees \_\_\_\_\_ only),

we \_\_\_\_\_ (indicate the name and address of the Bank) having its Head Office at \_\_\_\_\_ (address of the head Office) (hereinafter referred to as the Bank), , at the request of \_\_\_\_\_ [Contractor(s)], being the Guarantor under this Guarantee, do hereby irrevocably and unconditionally undertake to forthwith and immediately pay to the Employer, , an amount not exceeding Rs. \_\_\_\_\_ without any demur, immediately on demand from the Employer and without any reservation, protest, and recourse and without the Employer needing to prove or demonstrate reasons for its such demand

Any such demand made on the bank, shall be conclusive as regards the amount due and payable by the Bank under this guarantee. However, our liability under this guarantee shall be restricted to an amount not exceeding Rs. \_\_\_\_\_.

We undertake to pay to the Employer any money so demanded notwithstanding any dispute or disputes raised by the Contractor(s) in any suit or proceeding pending before any Court or Tribunal or Arbitrator or any other authority, our liability under this present being absolute and unequivocal.

The payment so made by us under this guarantee shall be a valid discharge of our liability for payment hereunder and the Contractor(s) shall have no claim against us for making such payment.

We, further agree that the guarantee herein contained shall remain in full force and effect during the period that would be taken for the performance of the said Contract and that it shall continue to be enforceable till all the dues of the Employer under or by virtue of the said Contract have been fully paid and its claims satisfied & the Employer certifies that the terms and conditions of the said Contract have been fully and properly carried out by the said contractor(s) or acceptance of the final bill or discharge of this guarantee by the Employer, whichever is earlier. This guarantee shall initially remain in force upto and including \_\_\_\_\_<sup>6</sup> and shall be extended from time to time for such period as may be desired by the Employer. Unless a demand or claim under this guarantee

is made on us in writing on or before the \_\_\_\_\_<sup>7</sup>, we shall be discharged from all the liability under this guarantee thereafter.

We, \_\_\_\_\_ (indicate the name of the Bank) \_\_\_\_\_ further agree with the Employer that the Employer shall have the fullest liberty without our consent and without affecting in any manner our obligations hereunder to vary any of the terms and conditions of the said Contract or to extend time of performance by the said contractor(s) from time to time or to postpone for any time or from time to time any of the powers exercisable by the Employer against the said contractor(s) and to forbear or enforce any of the terms and conditions relating to the said Contract and we shall not be relieved from our liability by any reason of any such variation or extension being granted to the said contractor(s) or for any forbearance, act or omission on the part of the Employer or any indulgence by the Employer to the said contractor(s) or by any such matter or thing whatsoever which under the law relating to sureties would but for this provision have effect of so relieving us.

The Bank also agrees that the Employer at its option shall be entitled to enforce this Guarantee against the Bank as a principal debtor, in the first instance without proceeding against the Contractor and notwithstanding any security or other guarantee that the Employer may have in relation to the Contractor's liabilities.

This Guarantee shall not be determined or affected by liquidation or winding up, dissolution or change of constitution or insolvency of the Contractor but shall in all respects and for all purposes be binding and operative until payment of all money payable to the Employer in terms thereof. This guarantee will not be discharged due to the change in the constitution of the Bank or the Contractor(s).

We, \_\_\_\_\_ BANK lastly undertake not to revoke this guarantee during its currency except with the previous consent of the Employer in writing.

Notwithstanding anything to the contrary contained hereinabove:

- a) The liability of the Bank under this Guarantee shall not exceed \_\_\_\_\_<sup>5</sup>
- b) This Guarantee shall be valid up to \_\_\_\_\_<sup>6</sup>
- c) Unless the Bank is served a written claim or demand on or before \_\_\_\_\_<sup>7</sup> all rights under this guarantee shall be forfeited and the Bank shall be relieved and discharged from all liabilities under this guarantee irrespective of whether or not the original bank guarantee is returned to the Bank.

We, \_\_\_\_\_ Bank, have power to issue this Guarantee under law and the undersigned as a duly authorized person has full powers to sign this Guarantee on behalf of the Bank.

Date \_\_\_\_\_ Day of \_\_\_\_\_

for \_\_\_\_\_ (indicate the name of the Bank) \_\_\_\_\_

(Signature of Authorised signatory)

<sup>1</sup> ADDRESS OF THE EMPLOYER. I.e Bharat Heavy Electricals Limited

<sup>2</sup> ADDRESS OF THE VENDOR /CONTRACTOR / SUPPLIER .

<sup>3</sup> DETAILS ABOUT THE NOTICE OF AWARD/CONTRACT REFERENCE

<sup>4</sup> CONTRACT VALUE

<sup>5</sup> BG AMOUNT IN FIGURES AND WORDS

<sup>6</sup> VALIDITY DATE

<sup>7</sup> DATE OF EXPIRY OF CLAIM PERIOD

**Note:**

1. Units are advised that expiry of claim period may be kept 3-6 months after validity date. It may be ensured that the same is in line with the agreement/ contract entered with the Vendor.
2. The BG should be on Non-Judicial Stamp paper/e-stamp paper of appropriate value as per Stamp Act prevailing in the State(s) where the BG is submitted or is to be acted upon or the rate prevailing in the State where the BG was executed, whichever is higher. The Stamp Paper/e-stamp paper shall be purchased in the name of Vendor/Contractor/Supplier /Bank issuing the guarantee.
3. In line with the GCC, SCC or contractual terms, Unit may carry out minor modifications in the Standard BG Formats. If required, such modifications may be carried out after taking up appropriately with the Unit/Region's Law Deptt.

**4. In Case of Bank Guarantees submitted by Foreign Vendors-**

- a. **From Nationalized/Public Sector / Private Sector/ Foreign Banks (BG issued by Branches in India)** can be accepted subject to the condition that the Bank Guarantee should be enforceable in the town/city or at nearest branch where the Unit is located i.e. Demand can be presented at the Branch located in the town/city or at nearest branch where the Unit is located.
- b. **From Foreign Banks (wherein Foreign Vendors intend to provide BG from local branch of the Vendor country's Bank)**
  - b.1 In such cases, in the Tender Enquiry/ Contract itself, it may be clearly specified that Bank Guarantee issued by **any of the Consortium Banks only** will be accepted by BHEL. As such, Foreign Vendor needs to make necessary arrangements for issuance of Counter- Guarantee by Foreign Bank in favour of the Indian Bank's (BHEL's Consortium Bank) branch in India. It is advisable that all charges for issuance of Bank Guarantee/ counter- Guarantee should be borne by the Foreign Vendor. The tender stipulation should clearly specify these requirements.
  - b.2 **In case, Foreign Vendors intend to provide BG from Overseas Branch of our Consortium Bank** (e.g. if a BG is to be issued by SBI Frankfurt), the same is acceptable. However, the procedure at **sl.no. b.1** will required to be followed.
  - b.3 The BG issued may preferably be subject to Uniform Rules for Demand Guarantees (URDG) 758 (as amended from time to time). The BG Format provided to them should clearly specify the same.

**BANK GUARANTEE FOR PERFORMANCE SECURITY**

Bank Guarantee No:

Date:

To  
NAME  
& ADDRESSES OF THE BENEFICIARY

Dear Sirs,

In consideration of Bharat Heavy Electricals Limited (hereinafter referred to as the 'Employer' which expression shall unless repugnant to the context or meaning thereof, include its successors and permitted assigns) incorporated under the Companies Act, 1956 and having its registered office at \_\_\_\_\_<sup>1</sup> through its Unit at \_\_\_\_\_ (name of the Unit) having awarded to (Name of the Vendor / Contractor / Supplier) with its registered office at \_\_\_\_\_<sup>2</sup> hereinafter referred to as the 'Vendor / Contractor / Supplier ', which expression shall unless repugnant to the context or meaning thereof, include its successors and permitted assigns), a contract Ref No \_\_\_\_\_ dated \_\_\_\_\_<sup>3</sup> valued at Rs \_\_\_\_\_<sup>4</sup> (Rupees -----)/FC \_\_\_\_\_ (in words \_\_\_\_\_) for \_\_\_\_\_<sup>5</sup> (hereinafter called the 'Contract') and the Vendor / Contractor / Supplier having agreed to provide a Contract Performance Bank Guarantee, equivalent to \_\_\_\_\_ % ( \_\_\_\_\_ . Percent) of the said value of the Contract to the Employer for the faithful performance of the Contract,

we, \_\_\_\_\_, (hereinafter referred to as the Bank), having registered/Head office at \_\_\_\_\_ and inter alia a branch at \_\_\_\_\_ being the Guarantor under this Guarantee, hereby, irrevocably and unconditionally undertake to forthwith and immediately pay to the Employer any sum or sums upto a maximum amount of Rs -----<sup>6</sup> ( Rupees -----) without any demur, immediately on first demand from the Employer and without any reservation, protest, and recourse and without the Employer needing to prove or demonstrate reasons for its such demand.

Any such demand made on the Bank shall be conclusive as regards the amount due and payable by the Bank under this guarantee. However, our liability under this guarantee shall be restricted to an amount not exceeding Rs. \_\_\_\_\_.

We undertake to pay to the Employer any money so demanded notwithstanding any dispute or disputes raised by the Vendor / Contractor / Supplier in any suit or proceeding pending before any Court or Tribunal, Arbitrator or any other authority, our liability under this present being absolute and unequivocal.

The payment so made by us under this Guarantee shall be a valid discharge of our liability for payment thereunder and the Vendor / Contractor / Supplier shall have no claim against us for making such payment.

We the \_\_\_\_\_ bank further agree that the guarantee herein contained shall remain in full force and effect during the period that would be taken for the performance of the said Contract/satisfactory completion of the performance guarantee period as per the terms of the Contract and that it shall continue to be enforceable till

all the dues of the Employer under or by virtue of the said Contract have been fully paid and its claims satisfied or discharged.

We, \_\_\_\_\_ BANK further agree with the Employer that the Employer shall have the fullest liberty without our consent and without affecting in any manner our obligations hereunder to vary any of the terms and conditions of the said Contract or to extend time of performance by the said Vendor / Contractor / Supplier from time to time or to postpone for any time or from time to time any of the powers exercisable by the Employer against the said Vendor / Contractor / Supplier and to forbear or enforce any of the terms and conditions relating to the said Contract and we shall not be relieved from our liability by reason of any such variation, or extension being granted to the said Vendor / Contractor / Supplier or for any forbearance, act or omission on the part of the Employer or any indulgence by the Employer to the said Vendor / Contractor / Supplier or by any such matter or thing whatsoever which under the law relating to sureties would but for this provision have effect of so relieving us.

The Bank also agrees that the Employer at its option shall be entitled to enforce this Guarantee against the Bank as a principal debtor, in the first instance without proceeding against the Vendor / Contractor / Supplier and notwithstanding any security or other guarantee that the Employer may have in relation to the Vendor / Contractor / Supplier's liabilities.

This Guarantee shall remain in force upto and including \_\_\_\_\_<sup>7</sup> and shall be extended from time to time for such period as may be desired by Employer.

This Guarantee shall not be determined or affected by liquidation or winding up, dissolution or change of constitution or insolvency of the Vendor / Contractor / Supplier but shall in all respects and for all purposes be binding and operative until payment of all money payable to the Employer in terms thereof.

Unless a demand or claim under this guarantee is made on us in writing on or before the \_\_\_\_\_<sup>8</sup> we shall be discharged from all liabilities under this guarantee thereafter.

We, \_\_\_\_\_ BANK lastly undertake not to revoke this guarantee during its currency except with the previous consent of the Employer in writing.

Notwithstanding anything to the contrary contained hereinabove:

- a) The liability of the Bank under this Guarantee shall not exceed \_\_\_\_\_<sup>6</sup>
- b) This Guarantee shall be valid up to \_\_\_\_\_<sup>7</sup>
- c) Unless the Bank is served a written claim or demand on or before \_\_\_\_\_<sup>8</sup> all rights under this guarantee shall be forfeited and the Bank shall be relieved and discharged from all liabilities under this guarantee irrespective of whether or not the original bank guarantee is returned to the Bank.

We, \_\_\_\_\_ Bank, have power to issue this Guarantee under law and the undersigned as a duly authorized person has full powers to sign this Guarantee on behalf of the Bank.

For and on behalf of  
(Name of the Bank)

Dated \_\_\_\_\_ .

Place of Issue \_\_\_\_\_ .

<sup>1</sup> NAME AND ADDRESS OF EMPLOYER I.e Bharat Heavy Electricals Limited

<sup>2</sup> NAME AND ADDRESS OF THE VENDOR /CONTRACTOR / SUPPLIER.

<sup>3</sup> DETAILS ABOUT THE NOTICE OF AWARD/CONTRACT REFERENCE

<sup>4</sup> CONTRACT VALUE

<sup>5</sup> PROJECT/SUPPLY DETAILS

<sup>6</sup> BG AMOUNT IN FIGURES AND WORDS

<sup>7</sup> VALIDITY DATE

<sup>8</sup> DATE OF EXPIRY OF CLAIM PERIOD

**Note:**

1. Units are advised that expiry of claim period may be kept 3-6 months after validity date. It may be ensured that the same is in line with the agreement/ contract entered with the Vendor.
2. The BG should be on Non-Judicial Stamp paper/e-stamp paper of appropriate value as per Stamp Act prevailing in the State(s) where the BG is submitted or is to be acted upon or the rate prevailing in the State where the BG was executed, whichever is higher. The Stamp Paper/e-stamp paper shall be purchased in the name of Vendor/Contractor/Supplier /Bank issuing the guarantee.
3. In line with the GCC, SCC or contractual terms, Unit may carry out minor modifications in the Standard BG Formats. If required, such modifications may be carried out after taking up appropriately with the Unit/Region's Law Deptt.

**4. In Case of Bank Guarantees submitted by Foreign Vendors-**

- a. **From Nationalized/Public Sector / Private Sector/ Foreign Banks (BG issued by Branches in India)** can be accepted subject to the condition that the Bank Guarantee should be enforceable in the town/city or at nearest branch where the Unit is located i.e. Demand can be presented at the Branch located in the town/city or at nearest branch where the Unit is located.
- b. **From Foreign Banks (wherein Foreign Vendors intend to provide BG from local branch of the Vendor country's Bank)**
  - b.1 In such cases, in the Tender Enquiry/ Contract itself, it may be clearly specified that Bank Guarantee issued by **any of the Consortium Banks only** will be accepted by BHEL. As such, Foreign Vendor needs to make necessary arrangements for issuance of Counter- Guarantee by Foreign Bank in favour of the Indian Bank's (BHEL's Consortium Bank) branch in India. It is advisable that all charges for issuance of Bank Guarantee/ counter- Guarantee should be borne by the Foreign Vendor. The tender stipulation should clearly specify these requirements.
  - b.2 **In case, Foreign Vendors intend to provide BG from Overseas Branch of our Consortium Bank** (e.g. if a BG is to be issued by SBI Frankfurt), the same is acceptable. However, the procedure at **sl.no. b.1** will required to be followed.
  - b.3 The BG issued may preferably be subject to Uniform Rules for Demand Guarantees (URDG) 758 (as amended from time to time). The BG Format provided to them should clearly specify the same.

<b>Sl. No.</b>	<b>Name of the bank</b>
1	State Bank of India
2	Canara Bank
3	IDBI Bank Limited
4	ICICI Bank Limited
5	HDFC Bank Limited
6	Axis Bank
7	IndusInd Bank Limited
8	Bank of Baroda
9	Exim Bank
10	Indian Bank
11	Punjab National Bank
12	Union Bank of India
13	Yes Bank Limited
14	RBL Bank Ltd.
15	Standard Chartered Bank
16	Indian Overseas Bank
17	Kotak Mahindra Bank Limited
18	Federal Bank Limited
19	Hongkong and Shanghai Banking Corporation Ltd





## DETAILS OF COMPANY PERFORMANCE

## A. Capacity Details:

Manufacturing Capacity (Major machines with Qty.)	Type of Major Machines	Qty.
Machines supplied during last 5 years (Year-wise with Qty.)	Scheduled Supply Period	Actual Supply Period
Outstanding Order Book position (Type of Machine with Qty. & name of customers*)		
Liquidation Plan of all machines including BHEL machines under consideration for ordering		

\* If any bidder is unable to give name of ALL the customer(s) due to confidentiality restrictions, they may give details without disclosing such customer's identity.

## B. Performance of supplies to BHEL:

Details of POs to be considered in last 5 years shall include (i) Last 5 POs fully executed and (ii) all POs overdue for supply and/or E&C. Details of all machines in the POs to be given.

Sl. No.	Name of M/c with broad specs.	Name of BHEL Unit	P.O. No. & Date	P.O. Value	Supply Date		Erection & Commissioning		Reason of delay, if any
					As per P.O.	Actual/ Likely	E&C period incl. job prove out as agreed (in days)	Actual / Likely period of E&C completion (in days)	
(1)	(2)	(3)	(4)	(5)	(6)	(7)	(8)	(9)	(10)
1.									
2.									
3.									
4.									

Note: 1. In case bidder has not received any Purchase Order in the last 5 years from any of the Units of BHEL, then 'NIL' should be indicated.

2. Reasons for delay to be explained in details.

3. BHEL reserves the right to reject the offer, if past performance of the bidder is evaluated to be unsatisfactory and/or false information is given by the bidder.

### Guidelines for Indian Agents of Foreign Suppliers

- 1.0 There shall be compulsory registration of agents for all Global (Open) Tender and Limited Tender. An agent who is not registered with BHEL shall apply for registration in the registration form in line with SEARP.
- 1.1 Registered agents will file an authenticated Photostat copy duly attested by a Notary Public/Original certificate of the Principal confirming the agency agreement and giving the status being enjoyed by the agent and the commission/ remuneration/ salary/ retainership being paid by the principal to the agent before the placement of order by BHEL.
- 1.2 Wherever the Indian representatives have communicated on behalf of their principals and the foreign parties have stated that they are not paying any commission to the Indian agents, and the Indian representative is working on the basis of salary or as retainer, a written declaration to this effect should be submitted by the party (i.e. Principal) before finalizing the order.
- 2.0 Disclosure of particulars of agents/ representatives in India, if any.**
- 2.1 Tenderers of Foreign nationality shall furnish the following details in their offers:
- 2.1.1 The Bidder(s)/ Contractor(s) of foreign origin shall disclose the name and address of the agents/ representatives in India if any and the extent of authorization and authority given to commit the Principals. In case the agent/ representative be a foreign Company, it shall be confirmed whether it is existing Company and details of the same shall be furnished.
- 2.1.2 The amount of commission/ remuneration included in the quoted price(s) for such agents/ representatives in India.
- 2.1.3 Confirmation of the Tenderer that the commission/ remuneration, if any, payable to his agents/ representatives in India, may be paid by BHEL in Indian Rupees only.
- 2.2 Tenderers of Indian Nationality shall furnish the following details in their offers:
- 2.2.1 The Bidder(s)/ Contractor(s) of Indian Nationality shall furnish the name and address of the foreign principals, if any, indicating their nationality as well as their status, i.e. whether manufacturer or agents of manufacturer holding the Letter of Authority of the Principal specifically authorizing the agent to make an offer in India in response to tender either directly or through the agents/ representatives.
- 2.2.2 The amount of commission/ remuneration included in the price (s) quoted by the Tenderer for himself.
- 2.2.3 Confirmation of the foreign principals of the Tenderer that the commission/ remuneration, if any, reserved for the Tenderer in the quoted price(s), may be paid by BHEL in India in equivalent Indian Rupees on satisfactory completion of the Project or supplies of Stores and Spares in case of operation items.
- 2.3 In either case, in the event of contract materializing, the terms of payment will provide for payment of the commission/ remuneration, if any payable to the agents/ representatives in India in Indian Rupees on expiry of 90 days after the discharge of the obligations under the contract.
- 2.4 Failure to furnish correct and detailed information as called for in paragraph 2.0 above will render the concerned tender liable to rejection or in the event of a contract materializing, the same liable to termination by BHEL. Besides this there would be a penalty of banning business dealings with BHEL or damage or payment of a named sum.

This format is applicable only to Indian Suppliers/ Agents supplying indigenous portion of Foreign Purchases.

\* In all other cases, extant guidelines of SEARP, 2010 are to be followed.

SEARP (SRF) Clause No	Detail
	<b>Name &amp; address of the firm</b>
1.0	<b>Products/ Systems / Services being considered for</b>
2.0	<b>General Information</b>
2.2	Name of Chief Executive
2.3	Details of authorized signatory
3.0	<b>Ownership Information</b>
3.1	Type of firm
3.2	Nature of Business <ul style="list-style-type: none"> <li>• Attach <b>authorization letter</b> and <b>agency agreement</b> from Principal (from whom capital equipment is procured)</li> <li>• Attach copy of declaration from Foreign Principal for <b>total guarantee/ warranty of indigenous supplies</b></li> </ul>
3.3	Year of establishment
3.4	Year of commencement of business
4.0	<b>Registration particulars</b>
4.1	Permanent Account No.
4.2 / 4.3	Sales Tax / TIN no
4.6	Service tax no. (in case of E&C)
5.0	<b>Organisational strength</b>
6.0	<b>Other particulars</b>
6.1	If the company is already registered with other units
6.2	Directors/ Partners, if related to any BHEL Employee
6.9	If any Ex BHEL Personnel employed by the Company
6.12	Details of pending legal issues with BHEL
6.13	Bank Account information
9.0	<b>Financial information</b>
9.6	Sales/ Turnover details of last 3 years (or from the date of incorporation whichever is less )

### **Annexure-III**

#### **IMPORTANT FOR FOREIGN VENDORS:**

- a) BHEL shall deal directly with foreign vendors, wherever required, for procurement of equipment/machine/goods. However, if the foreign principal desires to avail of the services of an Indian agent, then the foreign principal should ensure compliance to regulatory guidelines – which require mandatory submission of an Agency Agreement.
- b) It shall be incumbent on the Indian agent and the foreign principal to adhere to the relevant guidelines of Government of India, issued from time to time.
- c) The Agency Agreement should specify the precise relationship between the foreign OEM / foreign principal and their Indian agent and their mutual interest in the business. All services to be rendered by agent/associate, whether of general nature or in relation to the particular contract, must be clearly stated by the foreign supplier / Indian agent. Any payment, which the agent or associate receives in India or abroad from the OEM, whether as commission or as a general retainer fee should be brought on record in the Agreement and be made explicit in order to ensure compliance to laws of the country.
- d) Any agency commission to be paid by BHEL to the Indian agent shall be in Indian currency only.
- e) Tax deduction at source is applicable to the agency commission paid to the Indian agent as per the prevailing rules.
- f) In the absence of any agency agreement, BHEL shall not deal with any Indian agent (authorized representatives / associate / consultant, or by whatever name called) and shall directly with the foreign principal only for all correspondence and business puposes.
- g) The “Guidelines for Indian Agents of Foreign Suppliers” enclosed at Annexure – “A” shall apply in all such cases.
- h) The supply and execution of the Purchase Order (including indigenous supplies/service) shall be in the scope of the OEM/foreign principal. The OEM/foreign principal should submit their offer inclusive of all indigenous supplies/services and evaluation will be based on ‘total cost to BHEL’. In case OEM/foreign principal recommends placement of order(s) towards indigenous portion of supplies/services on Indian supplier(s)/agent on their behalf, the credentials/capacity/capability of the Indian supplier(s)/agent to make the supplies/services shall be checked by BHEL as per the extant guidelines of Supplier Evaluation, Approval & Review Procedure (SEARP), before opening of price bids. In this regard, details may be checked as per Annexure – “B” (enclosed). It will be the responsibility of the OEM/foreign principal to get acquainted with the evaluation requirements of Indian supplier/agent as per SERAP available on [www.bhel.com](http://www.bhel.com).
- i) The responsibility for successful execution of the contract (including indigenous supplies/services) lies with the OEM/foreign principal. All bank guarantees to this effect shall be in the scope of the OEM/foreign principal.

On Bidder's office letter pad

## Make in India (Model Certificate) Annexure-I

### Self-Declaration

Enquiry No.	
Enquiry Date	

In line with Government public procurement order Number P-45021/2/2017-B.E-II dated 15.06.2017, and further modified order dt. 28.05.2018, 29.05-2019 and 04.06.2020

I / We hereby declare that I / We are a "Local Supplier" meeting the requirement of minimum local content (.....%) defined in the above government notification for the goods against above mentioned enquiry Number.

Details of location at which local value addition will be made is as follows:

Door No.	
Street / Address 1	
Street / Address 2	
District	
State	
Country	
PIN Code	

We also understand that the false declarations will be considered as breach of Integrity and liable for action.

For Company Name:

Seal:

Signature:

Date:

Place:

(Please fill all Yellow color field )

## 1726146/2023/HERP-MAINT

PRICE BID FORMAT FOR FOREIGN BIDDERS					
MAKE & MODEL		BIDDER:			CURRENCY(FE):
S.No	Description	Remarks	Unit	Calculation	Quoted Value
1	Machine /Equipment along with units & Accessories		FE		
	Tinning		FE		
	White metal holding Furnace		FE		
	Ladle 200		FE		
	melting out station		FE		
	A/C		FE		
	T/C		FE		
	bearing shell pre heater		FE		
	<b>Total</b>				
2	Any other miscellaneous cost considered	To be quoted by bidder	FE		
3	Packing & Forwarding	To be quoted by bidder	FE		
4	Total Ex-works cost	To be quoted by bidder		1+2+3	
5	FOB cost in Foreign Exchange	To be quoted by bidder	FE		
6	Freight & Insurance	To be quoted by bidder	FE		
7	CIF	To be quoted by bidder		5+6	
8	FE Rupee parity Date ( TTSELL rate)	Fixed FE considered Rs 97.32 per GBP	INR/FE	FE Rate.....	
9	CIF in Indian Rupees - Total assesable		FE	9=7x8	
10	Basic Custom Duty	7.50%	%	10=7.5 % of 9	
11	Social welfare charge	10.00%	%	11= 10 % of (10)	
12	IGST	18.00%	%	12=18 % of (9+10+11)	
13	Any other cess		INR	13	
14	Total duty	Calculated	INR	14=10+11+12+13	
15	Total landed cost in India	Calculated	INR	15=14+9	
16	Inland Freight, Insurance & Incidentals		INR	16	
17	Landed Cost for supply at HERP Stores (14+15)	Calculated	INR	17=15+16	
18	Start up Assistance /Erection & Commissioning / Job Proving charges payable to Supplier (in Foreign Exchange)	To be quoted by bidder	FE	18	
19	Remote Assistance package for 6 month in Foreign Exchange	To be quoted by bidder	FE	19	
20	Any other Service Charges	To be quoted by bidder	FE	20	
21	Total Erection Cost in FE	Calculated	FE	21=18+19+20	
22	Total Erection Cost in Rs.	Calculated	INR	22=8x21	
23	IGST @ 18% on E&C charges	18%	%	23=18 % of 22	
24	Total Erection & Commissioning Cost in Rs.	Calculated	INR	24=22+23	
25	Total Supply & Erection & Commissioning Cost without ITC in Rs.	Calculated	INR	25=17+24	
26	Total cost considering ITC benefit, if applicable	Calculated	INR	26=25-12-23	
27	Total FE Content (in Rs.)	Calculated	INR	27=8x (7+21)	
28	Total FE Content (in FE)	Calculated	INR	28=(7+21)	

1726146/2023/HERP-MAINT

PRICE BID FORMAT FOR INDIAN BIDDERS					
MAKE & MODEL		BIDDER:			Rs in INR
S.No.	Description	Remarks	Unit		TO BE QUOTED
<b>1</b>	<b>Cost of Supply of Machine /Equipment along with units &amp; Accessories:</b>				
a	Basic cost of equipment	To be quoted by bidder	INR	-	
b	Tinning Bath		INR	-	
c	White metal holding Furnace		INR	-	
d	Ladle 200		INR	-	
e	Melting out station		INR	-	
f	Bearing shell pre heater		INR	-	
g	Miscellaneous item not covered above		INR	-	
				Sub Total (A)	
2	Packing & Forwarding	To be quoted by bidder	INR	B	
3	Freight & Insurance		INR	C	
4	Any other Charges		INR	D	
5	Total Cost of supply FOR BHEL VARANASI	Calculated	INR	F=A+B+C+D	
6	Installation, Commissioning & Erection Cost	To be quoted by bidder	INR	G	
7	Remote Assistance package	To be quoted by bidder	INR	H	
				GST@___% of F	
				GST@___% of (G+H)	
				Sub Total of GST(I)	
8	Total Value for Placement of Purchase order with GST	Calculated	INR	F+G+H+I	