



REQUIREMENT OF STUD, WASHER, SCREW &NUT

The Heavy Electricals Equipment Plant (HEEP) located in Haridwar, India is one of the major manufacturing plants of Bharat Heavy Electricals Ltd. The core business of HEEP includes design and manufacture of large steam and gas turbines, turbo generators, Defense Items and so on.

Details of items details as below:

SI. NO.	MAT CODE	ITEM DISCREPTION	Quantity (Nos)	Delivery (Days)
1	W97012800097	STUD, M8X20 AS PER UNI 5917, MATERIAL CLASS= 8.8, FINISH:ZINCO NICKEL N.STD:UNI 5917 SIZE: 212867332	100	45
2	W97012800100	STUD, M8X22 AS PER UNI 5917, MATERIAL CLASS: 8.8, FINISH:ZINCO NICKEL N.STD:UNI 5917 SIZE: 212867333	100	45
3	W97012801018	STUD M6X35 AS PER UNI 5917, MATERIAL CLASS: 8.8, ELECTROPLATED COATING: P2G AS PER ISO 4042 (ZINC- NICKEL) N.STD:UNI 5917 SIZE: p/n 212867308	100	45
4	W97012801026	STUD, M8X16 AS PER UNI 5917, MATERIAL CLASS: 8.8,ELECTROPLATED COATING: P2G AS PER ISO 4042 (ZINC- NICKEL) N.STD:UNI 5917 SIZE: p/n 212867330	100	45
5	W97012801115	STUD M8X45 AS PER UNI 5917, MATERIAL CLASS: 8.8, ELECTROPLATED COATING: P2G AS PER ISO 4042 (ZINC- NICKEL) N.STD:UNI 5917 SIZE: p/n 212867339	100	45
6	W97013401323	WASHER SPR, UNI8840-B5, MATERIAL : C75, ZINCO NICKEL PLATED. N.STD:UNI 8840 SIZE: P/N 210863821	100	45
7	W97012713097	HEX HEAD, SELF LOCKING SCREW M12X1.75X35 N.STD:UNI 5739 SIZE: P/N 127623626	100	45
8	W97013311189	NUT, SELF-LOCKING, M16X1.5 UNI 7473, MATL: 8.8, FINISH : ZINCO-NICKEL N.STD:UNI 7473 SIZE: P/N 212809253	100	45

1. ALL VENDORS TO PROVIDE POINT WISE REPLY/CONFIRMATION ALONG WITH RELEVANT SUPPORTING DOCUMENTS TO EACH AND EVERY POINT OF PRE-QUALIFICATION REQUIREMENT/PQR FOR ALL ENQUIRY ITEMS. NONCOMPLIANCE OF THESE MAY LEAD TO REJECTION OF OFFER AS THESE ARE ESSENTIAL CONDITION FOR PARTICIPATING IN TENDER ENQUIRY
2. KINDLY UPLOAD/ATTACH THE SPECIFICATION DETAILS/ CATALOGUE OF OFFERED ITEMS.
3. KINDLY ARRANGE TO **SUBMIT TECHNO-COMMERCIAL CHECKLIST** ALONG WITH YOUR OFFER.
4. VENDOR TO CONFIRM TO PROVIDE MATERIAL & DIMENSIONAL TEST CERTIFICATES AS PER ENQUIRY STANDARDS ALONG WITH MATERIAL DISPATCH.
5. VENDOR TO CONFIRM TO PROVIDE DOCUMENTS COVERING TECHNICAL PARAMETERS OF MATERIALS.
6. VENDOR TO CONFIRM TO PROVIDE DOCUMENTS KEEP PROPER CORRELATION WITH PO ITEMS AND THEIR QUANTITY.
7. VENDOR TO CONFIRM TO PROVIDE CERTIFICATE OF CONFORMANCE ALONG WITH MATERIAL DISPATCH.
8. VENDOR TO CONFIRM TO PROVIDE NON-REMOVABLE IDENTIFICATION OF ALL ITEMS AND THEIR REPORT ACCORDINGLY.

QUALIFYING CONDITIONS for all types of Fasteners

Following can quote:

- a) Manufacturer
- b) Dealer/Distributor
- c) Stockist
- d) Supplier

Sl.	PQR Requirement	Vendor Response	Vendor Response (Yes / No / Remarks, if any)
1.	Who can manufacture or supply ALL TYPES of Fasteners as per national and equivalent International standards	Vendor to confirm	
2.	Who can provide Material Test Certificate (MTC) from NABL certified / Govt. approved Labs / OEM certified lab.	Vendor to confirm	
3.	Who can provide Certificate of Conformance (COC) (<i>also known as Certificate of Conformity or Certificate of Compliance</i>)	Vendor to confirm	

TECHNICAL PARAMETERS CHECK LIST
DATA VALUES TO BE FILLED AND CONFIRMED BY VENDOR

ITEM CODE W97012800097
ITEM NAME STUD, M8X1.25X20
ITEM PART NO P/N 212867332

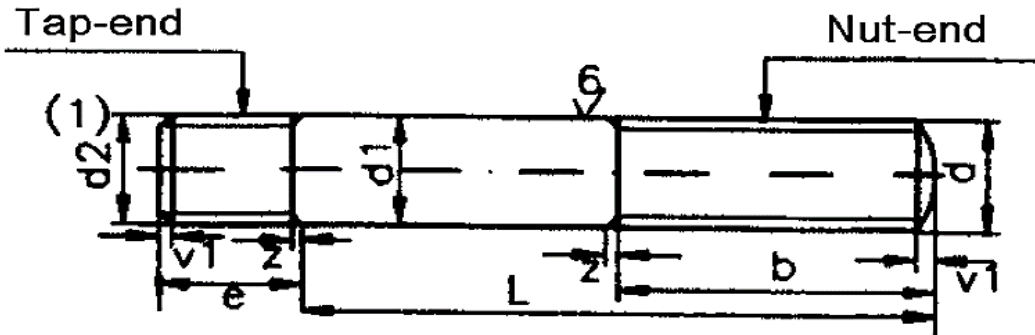

NOTE: Vendor to input parameters based on the specification of the item quoted.

SN.	PARAMETERS	VALUES	TOLERANCE	UNIT	RESPONSE TYPE	VENDOR RESPONSE
1	QUOTED AS PER	UNI 5917	-	-	To confirm	→
2	SIZE; d, d2	M8	6g	MM	Input Value	→
3	PITCH	1.25	-	MM	Input Value	→
4	Dia, d1	8	-0.15	MM	Input Value	→
5	TAP END (e)	20	-	MM	To confirm	→
6	NUT END (b)	17.5	-	MM	Input Value	→
7	LENGTH (L)	20	±0.42	MM	Input Value	→
8	MATERIAL	STEEL CLASS 8.8		-	Input Value	→
9	FINISH	ZINC- NICKEL / ZINK BLUE/ CADMIUM CHROMATE		-	To confirm	→
10	CERTIFICATION	Mechanical & Chemical properties		Y/N	To confirm	→
11	CERTIFICATION	Certificate of Conformance / Compliance (COC)		Y/N	To confirm	→

12. VENDOR REMARKS

TECHNICAL PARAMETERS CHECK LIST
DATA VALUES TO BE FILLED AND CONFIRMED BY VENDOR

ITEM CODE W97012800100
ITEM NAME STUD, M8x1.25x22
ITEM PART NO P/N 212867333

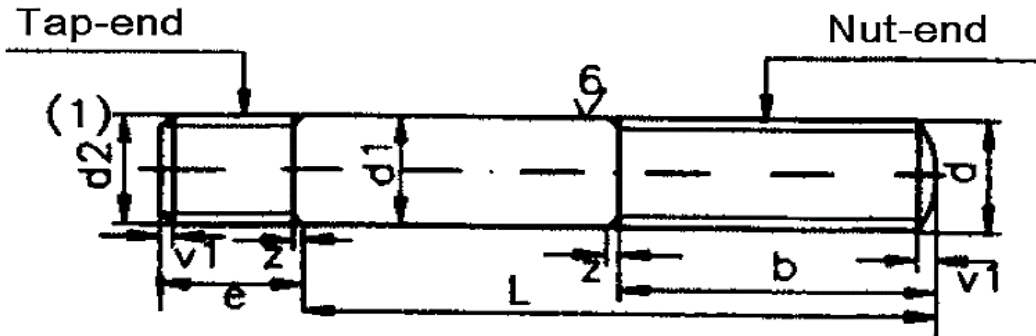

NOTE: Vendor to input parameters based on the specification of the item quoted.

SN.	PARAMETERS	VALUES	TOLERANCE	UNIT	RESPONSE TYPE	VENDOR RESPONSE
1	QUOTED AS PER	UNI 5917	-	-	To confirm	→
2	SIZE; d, d2	M8	6g	MM	Input Value	→
3	PITCH	1.25	-	MM	Input Value	→
4	Dia, d1	8	-0.15	MM	Input Value	→
5	TAP END (e)	20	-	MM	To confirm	→
6	NUT END (b)	17.75	-	MM	Input Value	→
7	LENGTH (L)	22	±0.42	MM	Input Value	→
8	MATERIAL	STEEL CLASS 8.8		-	Input Value	→
9	FINISH	ZINC- NICKEL / ZINK BLUE/ CADMIUM CHROMATE		-	To confirm	→
10	CERTIFICATION	Mechanical & Chemical properties		Y/N	To confirm	→
11	CERTIFICATION	Certificate of Conformance / Compliance (COC)		Y/N	To confirm	→

12. VENDOR REMARKS

TECHNICAL PARAMETERS CHECK LIST
DATA VALUES TO BE FILLED AND CONFIRMED BY VENDOR

ITEM CODE W97012801018
ITEM NAME STUD, M6x1x35
ITEM PART NO P/N 212867308

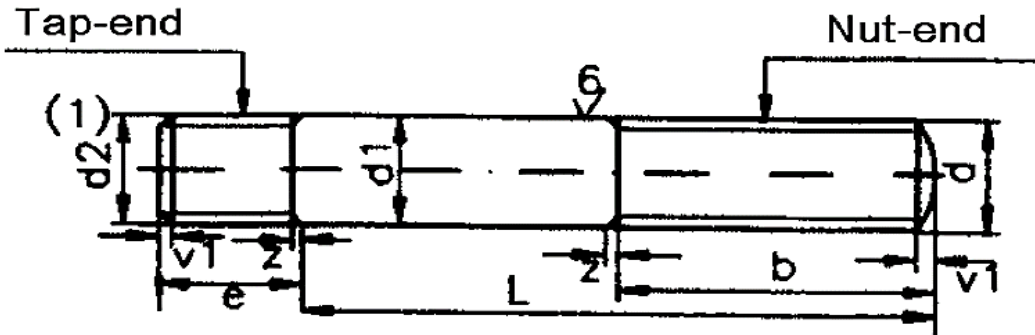

NOTE: Vendor to input parameters based on the specification of the item quoted.

SN.	PARAMETERS	VALUES	TOLERANCE	UNIT	RESPONSE TYPE	VENDOR RESPONSE
1	QUOTED AS PER	UNI 5917	-	-	To confirm	→
2	SIZE; d, d2	M6	6g	MM	Input Value	→
3	PITCH	1	-	MM	Input Value	→
4	Dia, d1	6	-0.12	MM	Input Value	→
5	TAP END (e)	15	-	MM	To confirm	→
6	NUT END (b)	18	-	MM	Input Value	→
7	LENGTH (L)	35	±0.42	MM	Input Value	→
8	MATERIAL	STEEL CLASS 8.8		-	Input Value	→
9	FINISH	ZINC- NICKEL / ZINK BLUE/ CADMIUM CHROMATE		-	To confirm	→
10	CERTIFICATION	Mechanical & Chemical properties		Y/N	To confirm	→
11	CERTIFICATION	Certificate of Conformance / Compliance (COC)		Y/N	To confirm	→

12. VENDOR REMARKS

**TECHNICAL PARAMETERS CHECK LIST
DATA VALUES TO BE FILLED AND CONFIRMED BY VENDOR**

ITEM CODE W97012801026
ITEM NAME STUD, M8x1.25x16
ITEM PART NO P/N 212867330

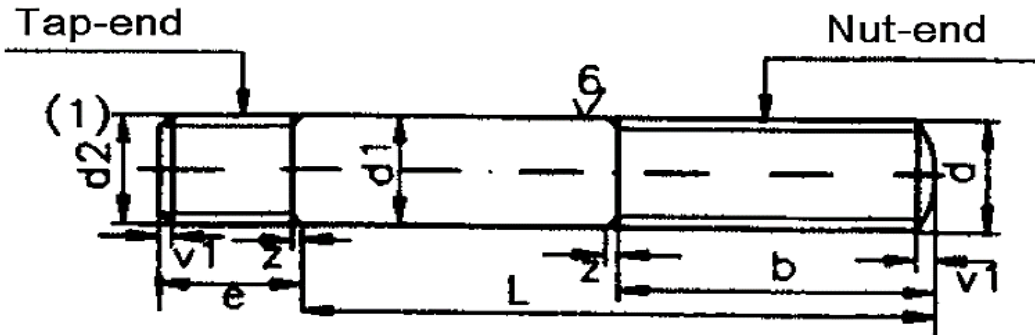

NOTE: Vendor to input parameters based on the specification of the item quoted.

SN.	PARAMETERS	VALUES	TOLERANCE	UNIT	RESPONSE TYPE	VENDOR RESPONSE
1	QUOTED AS PER	UNI 5917	-	-	To confirm	→
2	SIZE; d, d2	M8	6g	MM	Input Value	→
3	PITCH	1.25	-	MM	Input Value	→
4	Dia, d1	8	-0.15	MM	Input Value	→
5	TAP END (e)	20	-	MM	To confirm	→
6	NUT END (b)	13.5	-	MM	Input Value	→
7	LENGTH (L)	16	±0.42	MM	Input Value	→
8	MATERIAL	STEEL CLASS 8.8		-	Input Value	→
9	FINISH	ZINC- NICKEL / ZINK BLUE/ CADMIUM CHROMATE		-	To confirm	→
10	CERTIFICATION	Mechanical & Chemical properties		Y/N	To confirm	→
11	CERTIFICATION	Certificate of Conformance / Compliance (COC)		Y/N	To confirm	→

12. VENDOR REMARKS

TECHNICAL PARAMETERS CHECK LIST
DATA VALUES TO BE FILLED AND CONFIRMED BY VENDOR

ITEM CODE W97012801115
ITEM NAME STUD, M8x1.25x45
ITEM PART NO P/N 212867339

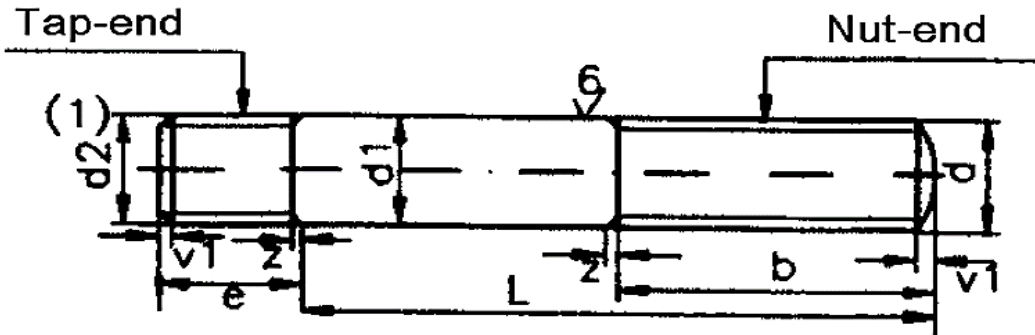

NOTE: Vendor to input parameters based on the specification of the item quoted.

SN.	PARAMETERS	VALUES	TOLERANCE	UNIT	RESPONSE TYPE	VENDOR RESPONSE
1	QUOTED AS PER	UNI 5917	-	-	To confirm	→
2	SIZE; d, d2	M8	6g	MM	Input Value	→
3	PITCH	1.25	-	MM	Input Value	→
4	Dia, d1	8	-0.15	MM	Input Value	→
5	TAP END (e)	20	-	MM	To confirm	→
6	NUT END (b)	22	-	MM	Input Value	→
7	LENGTH (L)	45	±0.42	MM	Input Value	→
8	MATERIAL	STEEL CLASS 8.8		-	Input Value	→
9	FINISH	ZINC- NICKEL / ZINK BLUE/ CADMIUM CHROMATE		-	To confirm	→
10	CERTIFICATION	Mechanical & Chemical properties		Y/N	To confirm	→
11	CERTIFICATION	Certificate of Conformance / Compliance (COC)		Y/N	To confirm	→

12. VENDOR REMARKS

**TECHNICAL PARAMETERS CHECK LIST
DATA VALUES TO BE FILLED AND CONFIRMED BY VENDOR**

ITEM MATCODE W97013401323
 ITEM NAME WASHER SPR, UNI8840-B5
 ITEM PART NO P/N 210863821

COMMERCIAL EQUIVALENTS

ALL DIMENSIONS IN MM

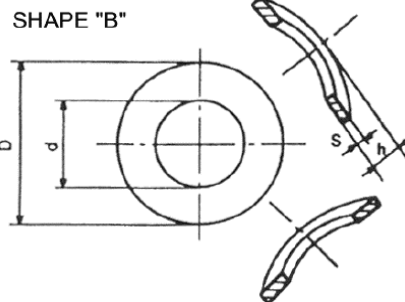

NOTE: Vendor to input parameters based on the specification of the Washer quoted.					
SN.	DESCRIPTION	SPECIFICATION #	TOLERANCE	RESPONSE TYPE	VENDOR RESPONSE
1	ITEM	WASHER SPR, UNI8840-B5	-	To confirm →	
2	SPECIFICATION & DIMENSIONS	UNI 8840-B 137B	DIN	-	To specify →
3	DIA (d)	5.3	H14	To input →	
4	DIA (D)	11	±0.55	To input →	
5	THICKNESS (h)	1.1-2.2	-	To input →	
6	THICKNESS (s)	0.5	±0.05	To input →	
7	MATERIAL	C75	-	To confirm →	
8	FINISH	ZINCO-NICKEL/ ZINK BLUE/ CADMIUM CHROMATE	-	To confirm →	
9	CERTIFICATION	MATERIAL TEST CERTIFICATE	-	Confirm to supply →	
10	CERTIFICATION	Certificate of Conformance / Compliance (COC)	-	Confirm to supply →	
11	VENDOR REMARKS				

Vendor to specify the specification number of the offered item.

TECHNICAL PARAMETERS CHECK LIST
DATA VALUES TO BE FILLED AND CONFIRMED BY VENDOR

ITEM CODE W97012713097
 ITEM NAME HEX HEAD, SELF LOCKING SCREW M12X1.75X35
 ITEM PART NO 127623626

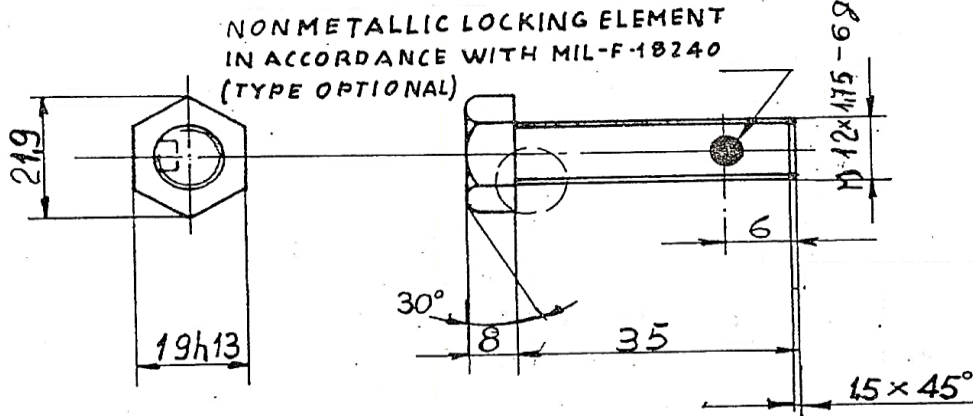

NOTE: Vendor to input parameters based on the specification of the item quoted.						
SN.	PARAMETERS	VALUES	TOLERANCE	UNIT	RESPONSE TYPE	VENDOR RESPONSE
1	QUOTED AS PER	UNI 5739	-	-	To confirm	→
2	SIZE; d	M12	6g	MM	Input Value	→
3	PITCH	1.75	-	MM	Input Value	→
4	THREAD LENGTH	FULL	-	-	To confirm	→
5	LENGTH (L)	35	-	MM	Input Value	→
6	HEAD THICKNESS (k)	8	nom.	MM	Input Value	→
7	FLAT TO FLAT (S)	19	nom.	MM	Input Value	→
8	LOCKING ELEMENT AS PER MIL-F-18240E	NON-METTALIC (LOCATION AS PER ABOVE SKETCH)		-	Input Value	→
9	SCREW MATERIAL	STEEL CLASS 8		-	Input Value	→
10	FINISH	ZINC- NICKEL / ZINK BLUE/ CADMIUM CHROMATE		-	To confirm	→
11	CERTIFICATION	Mechanical & Chemical properties		Y/N	To confirm	→
12	CERTIFICATION	Certificate of Conformance / Compliance (COC)		Y/N	To confirm	→

13. VENDOR REMARKS

**TECHNICAL PARAMETERS CHECK LIST
DATA VALUES TO BE FILLED AND CONFIRMED BY VENDOR**

ITEM MATCODE W97013311189

ITEM NAME NUT, SELF-LOCKING, M16

ITEM PART NO P/N 212809253

COMMERCIAL EQUIVALENTS

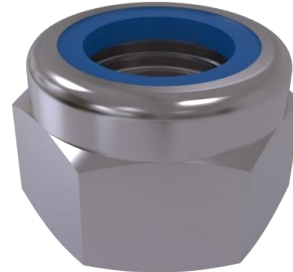
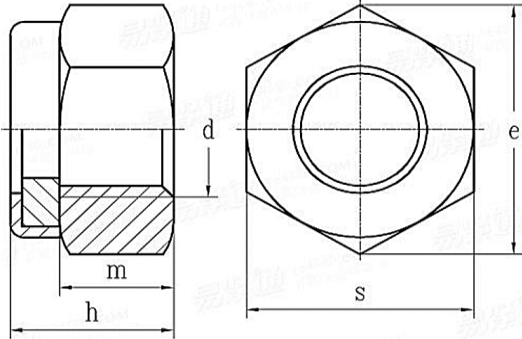

NOTE: Vendor to input parameters based on the specification of the Washer quoted.					
SN.	DESCRIPTION	SPECIFICATION #	TOLERANCE	RESPONSE TYPE	VENDOR RESPONSE
1	ITEM	NUT, SELF-LOCKING	-	To confirm →	
2	SPECIFICATION & DIMENSIONS	UNI 7473 DIN 982	-	To specify →	
3	THREAD SIZE (D)	M16 X 1.5	6H	To input →	
4	NUT HEIGHT (M), MIN.	12.8	-0.36	To input →	
5	THICKNESS (H), MAX	18	-0.43	To input →	
6	FLAT TO FLAT (S)	24	-0.33	To input →	
7	LOCKING ELEMENT	POLYAMIDE	-	To confirm →	
8	MATERIAL	STEEL CLASS 8	-	To confirm →	
9	FINISH	ZINCO-NICKEL/ ZINK BLUE/ CADMIUM	-	To confirm →	
10	CERTIFICATION	MATERIAL TEST CERTIFICATE	-	Confirm to supply →	
11	CERTIFICATION	Certificate of Conformance / Compliance (COC)	-	Confirm to supply →	
12	VENDOR REMARKS				

Vendor to specify the specification number of the offered item.

TECHNO-COMMERCIAL CHECKLIST

SL. NO.	TERMS & CONDITION	VENDOR CONFIRMATION /REMARKS / REPLY
1	BIDDER NAME	
2	GEM BID NO	
3	ITEM IS TO BE SUPPLIED AS PER TECHNICAL SPECIFICATION	
4	ALL VENDORS TO PROVIDE POINT WISE REPLY/CONFIRMATION ALONG WITH RELEVANT SUPPORTING DOCUMENTS TO EACH AND EVERY POINT OF PRE-QUALIFICATION REQUIREMENT/PQR FOR ALL ENQUIRY ITEMS. NONCOMPLIANCE OF THESE MAY LEAD TO REJECTION OF OFFER AS THESE ARE ESSENTIAL CONDITION FOR PARTICIPATING IN TENDER ENQUIRY	
5	KINDLY UPLOAD/ATTACH THE SPECIFICATION DETAILS/ CATALOGUE OF OFFERED ITEMS.	
6	VENDOR TO CONFIRM TO PROVIDE MATERIAL & DIMENSIONAL TEST CERTIFICATES AS PER ENQUIRY STANDARDS ALONG WITH MATERIAL DISPATCH	
7	VENDOR TO CONFIRM TO PROVIDE DOCUMENTS COVERING TECHNICAL PARAMETERS OF MATERIALS.	
8	VENDOR TO CONFIRM TO PROVIDE DOCUMENTS KEEP PROPER CORRELATION WITH PO ITEMS AND THEIR QUANTITY	
9	VENDOR TO CONFIRM TO PROVIDE CERTIFICATE OF CONFORMANCE ALONG WITH MATERIAL DISPATCH	
10	VENDOR TO CONFIRM TO PROVIDE NON-REMOVABLE IDENTIFICATION OF ALL ITEMS AND THEIR REPORT ACCORDINGLY	
11	<p>RISK PURCHASE: IN CASE OF ABNORMAL DELAYS (BEYOND THE MAXIMUM LATE DELIVERY PERIOD AS PER LD CLAUSE) IN SUPPLIES / DEFECTIVE SUPPLIES OR NONFULFILLMENT OF ANY OTHER TERMS AND CONDITIONS GIVEN IN PURCHASE ORDER, BHEL MAY CANCEL THE PURCHASE ORDER IN FULL OR PART THEREOF, AND MAY ALSO MAKE THE PURCHASE OF SUCH MATERIAL FROM ELSEWHERE / ALTERNATIVE SOURCE AT THE RISK AND COST OF THE SUPPLIER. BHEL WILL TAKE ALL REASONABLE STEPS TO GET THE MATERIAL FROM ALTERNATE SOURCE AT OPTIMUM COST. IF BIDDER DOES NOT AGREE TO THE ABOVE RISK PURCHASE CLAUSE, BHEL RESERVES THE RIGHT TO REJECT THE OFFER. IN CASE FOR COMPELLING REASONS BHEL ACCEPTS THE OFFER WITHOUT ACCEPTANCE OF THIS CLAUSE BY THE BIDDER AND IN THE EVENTUALITY OF RISK PURCHASE, APPROPRIATE ACTION WILL BE TAKEN AS PER BHEL EXTANT RULES. THIS WILL BE WITHOUT PREJUDICE TO ANY OTHER RIGHT OF BHEL UNDER THE CONTRACT OR UNDER GENERAL LAW.</p>	
12	<p>ACTION AGAINST BIDDERS / VENDOR / SUPPLIER / CONTRACTOR IN CASE OF DEFAULT: IN ORDER TO PROTECT THE COMMERCIAL INTERESTS OF BHEL, BHEL SHALL TAKE ACTION AGAINST SUPPLIES / CONTRACTORS BY WAY OF SUSPENSION OF BUSINESS DEALINGS, WHO EITHER FAIL TO PERFORM OR ARE IN DEFAULT WITHOUT ANY REASONABLE CAUSE, CAUSE LOSS OF BUSINESS/ MONEY/ REPUTATION, INDULGE IN MALPRACTICES, CHEATING, BRIBERY, FRAUD OR ANY OTHER MISCONDUCT OR FORMATION OF CARTELS SO AS TO INFLUENCE THE BIDDING PROCESS OR INFLUENCE THE PRICE ETC.</p> <p>SUSPENSION OF BUSINESS DEALINGS COULD BE IN THE FORM OF “HOLD” OR “BANNING” A SUPPLIER/ CONTRACTOR OR A BIDDER AND SHALL BE AS PER “GUIDELINES FOR SUSPENSION OF BUSINESS DEALINGS WITH SUPPLIERS/ CONTRACTORS” AVAILABLE AT BHEL’S WEBSITE “https://www.bhel.com/guidelines-suspension-business-dealings-supplierscontractors”</p>	

1. ALL VENDORS TO PROVIDE POINT WISE REPLY/CONFIRMATION ALONG WITH RELEVANT SUPPORTING DOCUMENTS TO EACH AND EVERY POINT OF PRE-QUALIFICATION REQUIREMENT/PQR FOR ALL ENQUIRY ITEMS. NONCOMPLIANCE OF THESE MAY LEAD TO REJECTION OF OFFER AS THESE ARE ESSENTIAL CONDITION FOR PARTICIPATING IN TENDER ENQUIRY
2. KINDLY UPLOAD/ATTACH THE SPECIFICATION DETAILS/ CATALOGUE OF OFFERED ITEMS.
3. KINDLY ARRANGE TO **SUBMIT TECHNO-COMMERCIAL CHECKLIST** ALONG WITH YOUR OFFER.
4. VENDOR TO CONFIRM TO PROVIDE MATERIAL & DIMENSIONAL TEST CERTIFICATES AS PER ENQUIRY STANDARDS ALONG WITH MATERIAL DISPATCH.
5. VENDOR TO CONFIRM TO PROVIDE DOCUMENTS COVERING TECHNICAL PARAMETERS OF MATERIALS.
6. VENDOR TO CONFIRM TO PROVIDE DOCUMENTS KEEP PROPER CORRELATION WITH PO ITEMS AND THEIR QUANTITY.
7. VENDOR TO CONFIRM TO PROVIDE CERTIFICATE OF CONFORMANCE ALONG WITH MATERIAL DISPATCH.
8. VENDOR TO CONFIRM TO PROVIDE NON-REMOVABLE IDENTIFICATION OF ALL ITEMS AND THEIR REPORT ACCORDINGLY.
9. MSE/MII: THE SUPPLIER NEEDS TO SUBMIT/UPDATE MSE/MII CREDENTIALS ON GEM PORTAL DURING PROFILE UPDATION/ OFFER SUBMISSION STAGE. THE MSE DATA SUBMITTED IS CROSS VERIFIED BY GEM WITH GOVT. OF INDIA UDYAM/NSIC DATABASE THROUGH API INTEGRATION ON REAL TIME BASIS AND FOR MII, A SELF DECLARATION IS BEING GIVEN AND AUTHENTICATED BY AADHAR OTP. IF THE SELLER FAILS TO CLAIM MSE/MII PROVISION ON GEM PORTAL AT PROFILE UPDATION/BID SUBMISSION STAGE, THE SAID SELLER WILL BECOME INELIGIBLE FOR GETTING THE MSE/MII BENEFITS FOR THAT BID AUTOMATICALLY. THE VENDOR CAN ALWAYS CONTACT THE GEM HELPDESK, IN CASE OF ANY ISSUES.
10. THE PRICE QUOTE BY BIDDER SHOULD BE INCLUSIVE OF GST & SHOULD BE ON BHEL HEEP HARIDWAR STORES BASIS.
11. BIDDER'S OFFER IS LIABLE TO BE REJECTED IF THEY DON'T UPLOAD ANY OF THE CERTIFICATES / DOCUMENTS SOUGHT IN THE BID DOCUMENT, ATC AND CORRIGENDUM IF ANY.
12. **RISK PURCHASE:** IN CASE OF ABNORMAL DELAYS (BEYOND THE MAXIMUM LATE DELIVERY PERIOD AS PER LD CLAUSE) IN SUPPLIES / DEFECTIVE SUPPLIES OR NONFULFILLMENT OF ANY OTHER TERMS AND CONDITIONS GIVEN IN PURCHASE ORDER, BHEL MAY CANCEL THE PURCHASE ORDER IN FULL OR PART THEREOF, AND MAY ALSO MAKE THE PURCHASE OF SUCH MATERIAL FROM ELSEWHERE / ALTERNATIVE SOURCE AT THE RISK AND COST OF THE SUPPLIER. BHEL WILL TAKE ALL REASONABLE STEPS TO GET THE MATERIAL FROM ALTERNATE SOURCE AT OPTIMUM COST. IF BIDDER DOES NOT AGREE TO THE ABOVE RISK PURCHASE CLAUSE, BHEL RESERVES THE RIGHT TO REJECT THE OFFER. IN CASE FOR COMPELLING REASONS BHEL ACCEPTS THE OFFER WITHOUT ACCEPTANCE OF THIS CLAUSE BY THE BIDDER AND IN THE EVENTUALITY OF RISK PURCHASE, APPROPRIATE ACTION WILL BE TAKEN AS PER BHEL EXISTANT RULES. THIS WILL BE WITHOUT PREJUDICE TO ANY OTHER RIGHT OF BHEL UNDER THE CONTRACT OR UNDER GENERAL LAW.
13. **ACTION AGAINST BIDDERS / VENDOR / SUPPLIER / CONTRACTOR IN CASE OF DEFAULT:**
IN ORDER TO PROTECT THE COMMERCIAL INTERESTS OF BHEL, BHEL SHALL TAKE ACTION AGAINST SUPPLIES / CONTRACTORS BY WAY OF SUSPENSION OF BUSINESS DEALINGS, WHO EITHER FAIL TO PERFORM OR ARE IN DEFAULT WITHOUT ANY REASONABLE CAUSE, CAUSE LOSS OF BUSINESS/ MONEY/ REPUTATION, INDULGE IN MALPRACTICES, CHEATING, BRIBERY, FRAUD OR ANY OTHER MISCONDUCT OR FORMATION OF CARTELS SO AS TO INFLUENCE THE BIDDING PROCESS OR INFLUENCE THE PRICE ETC.
SUSPENSION OF BUSINESS DEALINGS COULD BE IN THE FORM OF "HOLD" OR "BANNING" A SUPPLIER/ CONTRACTOR OR A BIDDER AND SHALL BE AS PER "GUIDELINES FOR SUSPENSION OF BUSINESS DEALINGS WITH SUPPLIERS/ CONTRACTORS" AVAILABLE AT BHEL'S WEBSITE <https://www.bhel.com/guidelines-suspension-business-dealings-supplierscontractors>

14. BIDDERS ARE ADVISED TO CHECK APPLICABLE GST ON THEIR OWN BEFORE QUOTING. BUYER WILL NOT TAKE ANY RESPONSIBILITY IN THIS REGARDS. GST REIMBURSEMENT WILL BE AS PER ACTUALS OR AS PER APPLICABLE RATES (WHICHEVER IS LOWER), SUBJECT TO THE MAXIMUM OF QUOTED GST %.

15. BIDDER SHALL SUBMIT THE FOLLOWING DOCUMENTS ALONG WITH THEIR BID FOR VENDOR CODE CREATION:
A. COPY OF PAN CARD B. COPY OF GSTIN C. COPY OF MSE CERIFICATE

16. DEDICATED /TOLL FREE TELEPHONE NO. FOR SERVICE SUPPORT: BIDDER/OEM MUST HAVE DEDICATED/TOLL FREE TELEPHONE NO. FOR SERVICE SUPPORT.

17. DATA SHEET OF THE PRODUCT(S) OFFERED IN THE BID, ARE TO BE UPLOADED ALONG WITH THE BID DOCUMENTS. BUYERS CAN MATCH AND VERIFY THE DATA SHEET WITH THE PRODUCT SPECIFICATIONS OFFERED. IN CASE OF ANY UNEXPLAINED MISMATCH OF TECHNICAL PARAMETERS, THE BID IS LIABLE FOR REJECTION.

18. SCOPE OF SUPPLY (BID PRICE TO INCLUDE ALL COST COMPONENTS): ONLY SUPPLY OF GOODS.

19. PRODUCTS SUPPLIED SHALL BE NONTOXIC AND HARMLESS TO HEALTH. IN THE CASE OF TOXIC MATERIALS, MATERIAL SAFETY DATA SHEET MAY BE FURNISHED ALONG WITH THE MATERIAL.

20. WHILE GENERATING INVOICE IN GEM PORTAL, THE SELLER MUST UPLOAD SCANNED COPY OF GST INVOICE AND THE SCREENSHOT OF GST PORTAL CONFIRMING PAYMENT OF GST.

21. PAYMENT TERMS SHALL BE AS PER FOLLOWINGS:

a) **For Non-MSME bidders:** 100% payment along with taxes, freight & insurance will be made after receipt and acceptance of material and within 90 days from the date of invoice subject to submission of non-discrepant documents within 15 days of supply as per terms and conditions of Purchase Order. (MSME means Micro, Small & Medium Enterprises) (THIS IS IN SUPERSESSION OF 10 DAYS' TIME AS PROVIDED IN CLAUSE 12 OF GEM GTC).

b) **FOR MSE BIDDER:** For MSEs (covered under MSME Act) which are registered and periodically renewed with BHEL, the payment will be made within 45 days or as prescribed in the relevant act. Benefits of MSE (such as EMD Waiver, Tender fee exemption, Price preference, Payment preference etc.) will be given only to those MSE Vendors who are manufacturers of offered items against the NIT. No MSE benefits shall be provided to Agents / Stockists /Dealers / Traders etc. for the items offered but not manufactured by themselves.”

c) **FOR MEDIUM ENTERPRISES:** 100% payment along with taxes, freight & insurance will be made after receipt and acceptance of material and within 60 days from the date of invoice subject to submission of non-discrepant documents within 15 days of supply as per terms and conditions of Purchase Order.

d) Please note that vendor to adhere to the payment terms as per above. No deviation in payment terms shall be accepted. Vendor to submit their offer accordingly.