



**Bharat Heavy Electricals Limited**  
**Heavy Equipment Repair Plant (HERP)**

Tarna, Shivpur, Varanasi - 221003

Enquiry Ref No.: **HERP/OT/ E-588-22-0001-69-1**

Dated 30.05.2022

**TENDER DOCUMENT**

**PART I: TECHNO-COMMERCIAL BID**

**PART II: PRICE BID &**

**PART III: - SUPPLIER REGISTRATION FORM (SRF)**

**TENDER FOR SUPPLY, INSTALLATION & COMMISSIONING OF CENTRIFUGAL CASTING  
MACHINE AS PER ANNEXURE-A.**



**MATERIALS MANAGEMENT DEPARTMENT  
BHARAT HEAVY ELECTRICALS LIMITED  
HEAVY EQUIPMENT REPAIR PLANT  
TARNA, SHIVPUR  
VARANASI – 221 003 (U.P)**



**TABLE OF CONTENTS**

SL.No.	Section	Annexure	REQUIRED IN TENDER PART
01	NOTICE INVITING TENDER	I	-
02	SUPPLIER REGISTRATION FORM (SRF)	II	PART-I
03	SPECIAL INSTRUCTION TO BIDDERS	III	-
04	ITEM DETAILS AND DELIVERY SCHEDULE	IV	-
05	PRE QUALIFICATION REQUIREMENT & TECHNICAL SPECIFICATIONS	V	PART-I
06	GENERAL TERMS AND CONDITIONS OF TENDER	VI	PART-I
07	DETAILS OF COMPOSITION OF PART-I (TECHNO-COMMERCIAL BID), PART-II (PRICE BID) & PART-III (VENDOR REGISTRATION FORM)	VII	-



# Bharat Heavy Electricals Limited

## Heavy Equipment Repair Plant (HERP)

Tarna, Shivpur, Varanasi - 221003

### NOTICE INVITING TENDER

Enquiry Ref No. : **HERP/OT/ E-588-22-0001-69-1** Dated 30.05.2022

Annexure-I

The Heavy Equipment Repair Plant (HERP) located in Varanasi, Uttar Pradesh, India is one of the manufacturing plants of Bharat Heavy Electricals Ltd. The core business of HERP includes supply of Bowl Mill Spares and Turbine Spares. Online offers through e-procurement are invited from the interested parties (registered as well as unregistered) for the supply of the items mentioned at Annexure-V.

The tender documents, Supplier Registration Form (SRF) & Drawings/Specification of item can be downloaded from our web site [www.bhel.com](http://www.bhel.com), <https://herp.bhel.com> and <https://eprocurebhel.co.in>. BHEL will not issue tender in hard copy. It shall be downloaded from the above mentioned websites. **The bids shall be submitted online only. No bids through e mail /Fax will be accepted by BHEL.**

Tenders will be received up to **02.00 P.M. on 10.06.2022** and will be opened on the same day at **04:00 P.M.** online at BHEL, HERP Varanasi. **Please note that tender received after due date & time (02.00 PM on 10.06.2022) may not be opened.** BHEL will not be responsible for any type of net connectivity/digital signature related delay. Tender will be opened on the due date and time in the presence of authorized representative of the bidders who may like to be present. The authorized representative should bring authority letter from their firm for attending the bid opening.

Amendments / Corrigendum, if any, will be hosted on above mentioned websites only. Other terms and conditions will be as per tender documents.

1. **Address for Tender submission:** [www.eprocurebhel.co.in](http://www.eprocurebhel.co.in)

2. **For any information/clarification, vendor may contact the following officials of HERP:**

1. Shri. Praveen Kumar  
Dy. Engineer (Purchase)  
Ph No: - 0542-2720876  
Mob. 9488382359

Email: - [kumarpraveen@bhel.in](mailto:kumarpraveen@bhel.in)

2. Shri. Prashant Singh  
Dy. Manager (Pur.)  
Ph No: - 0542-2720867  
Mob. 9026184315

Email: - [prashants@bhel.in](mailto:prashants@bhel.in)



**Bharat Heavy Electricals Limited**  
**Heavy Equipment Repair Plant (HERP)**

Tarna, Shivpur, Varanasi - 221003

**Annexure-I**

**Part-III - Supplier Registration Documents and Part-I-Techno Commercial bid:-**

Part I & III of the tenders will be opened online by BHEL on the date of opening of this tender in the presence of tenderers who are present at the date and time.

**Part-II - Price bid:-**

The price bid should contain prices only. Price bid will be opened only for those parties who have qualified in techno - commercial bid.

**Note: - BHEL takes no responsibility for any delay / loss of documents or correspondence sent by courier or post. Late tenders shall be rejected out rightly.**





**Bharat Heavy Electricals Limited**  
**Heavy Equipment Repair Plant (HERP)**

Tarna, Shivpur, Varanasi - 221003

**Annexure-II**

**SUPPLIER REGISTRATION FORM**

Supplier Registration Form for indigenous vendor is enclosed as per Part-III - Vendor Registration Form (SRF) along with tender.

(PDF Format attached, 08 Pages for indigenous vendors)

**Note:** Vendors who are already registered at BHEL, HERP, Varanasi need not to submit the Supplier Registration Form. They need to mention their Supplier Code only.





**Annexure-III**

**SPECIAL INSTRUCTIONS TO BIDDERS FOR OPEN TENDER DEFINITION**

- a. Registered Vendors** - Are those who are registered with BHEL, HERP, Varanasi.
- b. Un-registered Vendors** - Are those who are not registered with BHEL, HERP, Varanasi.
- c. ESSENTIAL INSTRUCTIONS:**
1. The tenders shall be submitted in two parts as described above on or before the due date:
    - i. Part I - Techno -Commercial Bid,
    - ii. Part II - Price Bid
  2. Part-II (Price Bids) along with supplementary price bids if any will be opened at the subsequently decided date of only those bidders whose techno-commercial bid has been found to be acceptable/suitable.
  3. All parties have to quote in Indian currency only as it is Open Tender (**Non Global i.e. only Indian vendors are invited**).
  4. Evaluation of Bid: - The bid shall be evaluated on Cost to BHEL basis. The loading /other cost, if any determined at later stage, shall be communicated to the vendor.
  5. Tenders when finalized shall be in the name of the bidder only and change of name during tender evaluation (without certificate from registrar of company) and after submission of the tender is liable to make the offer ineligible for participation.
  6. BHEL will evaluate the technical bids against essential criteria/requirements. BHEL may seek clarifications, if required, from the bidders. **The offers of those bidders, who are unable to respond in specified time frame, may likely be ignored/may be processed further with the terms and conditions already submitted with the respective bidder's risk and cost .**
  7. Suitability of delivery shall be the important criteria for evaluation of techno commercial bid and the bids falling within the delivery period and meeting the last delivery requirement shall be considered. Delivery period quoted by the parties beyond the required delivery period may not be considered.
  8. FINALITY OF MANAGEMENT DECISION  
At all places in the preceding clauses, BHEL Management's decision shall be final.

**IN CASE YOU ARE NOT MAKING AN OFFER AGAINST THIS ENQUIRY, THEN PLEASE ARRANGE TO SEND MAIL OF REGRET IF YOU HAVE DOWNLOADED THE TENDER DOCUMENTS.**



**Bharat Heavy Electricals Limited**  
**Heavy Equipment Repair Plant (HERP)**

Tarna, Shivpur, Varanasi - 221003

Annexure-IV

ITEM DETAILS AND DELIVERY SCHEDULE

SI No	Material Description	Material Code	Quantity	Unit
1	SUPPLY, INSTALLATION & COMMISSIONING OF CENTRIFUGAL CASTING MACHINE AS PER ANNEXURE-A.	RVA210700001	1.0	SET

DELIVERY SHOULD BE WITHIN 06 MONTH FROM THE DATE OF PURCHASE ORDER. HOWEVER EARLY DELIVERY IS ACCEPTABLE.

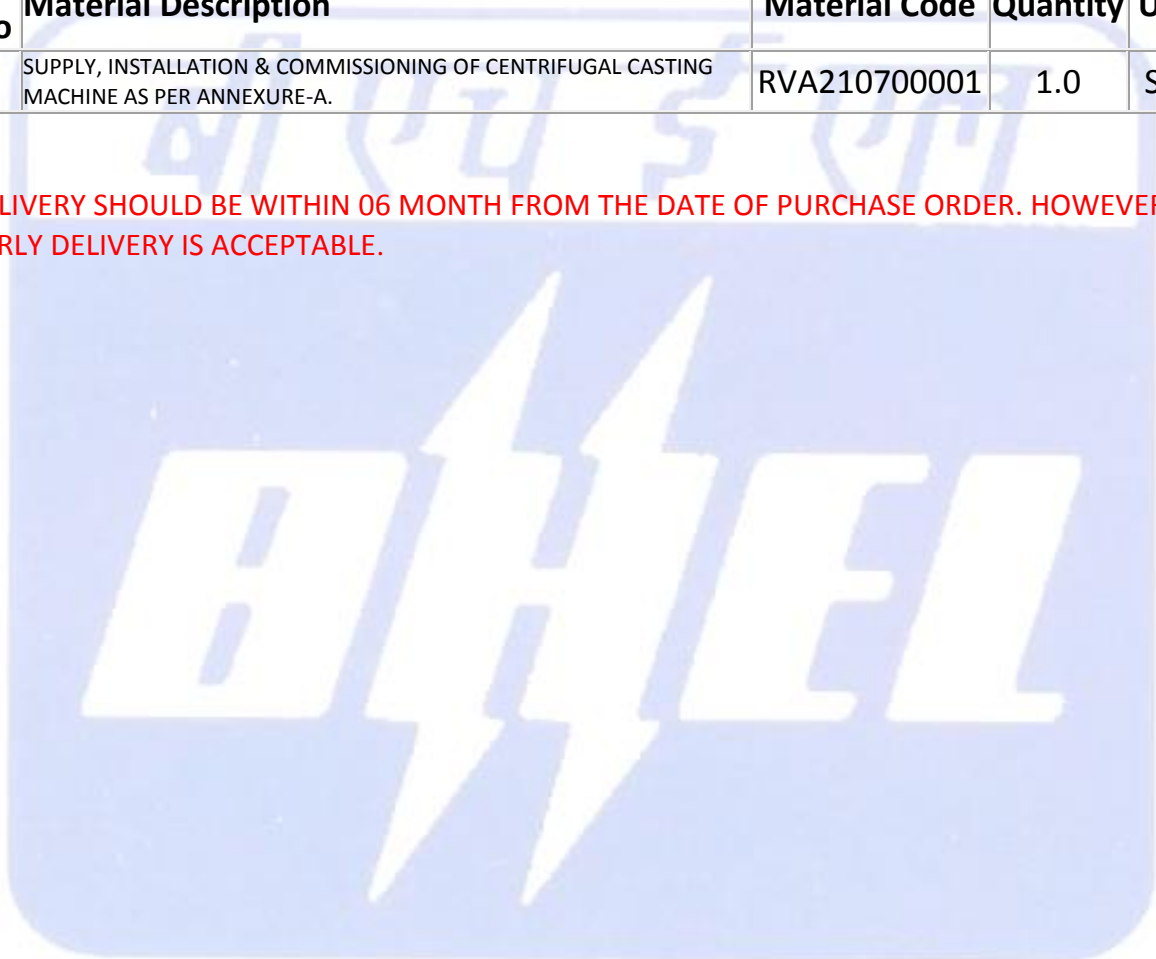



**Bharat Heavy Electricals Limited**  
**Heavy Equipment Repair Plant (HERP)**

Tarna, Shivpur, Varanasi - 221003

**Annexure-V**

PRE QUALIFICATION CRITERIA & TECHNICAL SPECIFICATIONS

PRE QUALIFICATION CRITERIA & TECHNICAL SPECIFICATIONS for indigenous vendor is enclosed as per **Annexure- A, B, C, D, Plant Standards, Integrity Pact, PBG format and Annexure- I (MII)** along with tender.





# Bharat Heavy Electricals Limited

## Heavy Equipment Repair Plant (HERP)

Tarna, Shivpur, Varanasi - 221003

### Annexure-VI

ITEM DESCRIPTION:  
ENQUIRY NO:

Sl No	BHEL STANDARD TERMS & CONDITIONS	CONFIRMATION OF SUPPLIER YES / NO
1	<p>A) OFFER MUST BE SUBMITTED IN TWO PART BID SYSTEM NAMELY TECHNO-COMMERCIAL BID &amp; PRICE BID FOR THE ITEM AS PER ENQUIRY IN SEPARATE SEALED COVERS:</p> <p>(I) TECHNO – COMMERCIAL BID &amp; (II) PRICE BID SHOULD BE CLEARLY SUPERSCRIBED THE ENQUIRY NO. AND DUE DATE ON THE ENVELOPES.</p> <p>(B) UN-PRICED OFFER WITH TECHNICAL BID IS REQUIRED TO BE FURNISHED BY THE VENDOR. TECHNICAL OFFER SHOULD CLEARLY REFLECT AT LEAST OUR MATERIAL CODE, ITEM DESCRIPTION &amp; QUANTITY.</p> <p>(C) THE DIFFERENCE BETWEEN “UN-PRICED OFFER” AND “PRICED OFFER” SHOULD BE ONLY THE PRICES WHEREVER APPLICABLE. THE RATES AND AMOUNT SHOULD BE CLEARLY WRITTEN IN FIGURES AND WORDS BOTH WITHOUT ANY CUTTING / OVERWRITING.</p> <p>(D) <b>IMPORTANT POINT FOR VENDOR WHO HAVE NOT SUBMITTED THE SRF (SUPPLIER REGISTRATION FORM) SO FAR:</b> THE VENDORS, WHO HAVE NOT SUBMITTED THE SRF SO FAR, MUST SUBMIT THE SAME ALONG WITH PART- 1 BID. THE SRF TO BE DOWNLOADED FROM WWW.BHEL.COM OR <a href="https://herp.bhel.com">https://herp.bhel.com</a>.</p>	
2	PART-I CONTAINING THE TECHNO-COMMERCIAL BID WILL BE OPENED ON THE DATE AND TIME SPECIFIED IN THE ENQUIRY, IN THE PRESENCE OF THOSE TENDERERS WHO WISH TO ATTEND. PART-II i.e., PRICE BID WILL BE OPENED ONLY OF THOSE BIDDERS WHO ARE FOUND TECHNO-COMMERCIALY SUITABLE AFTER SCRUTINY OF THEIR PART-I OFFERS.	
3	NO REVISED OFFERS WILL BE ACCEPTED UNLESS ASKED BY BHEL AFTER OPENING OF PART-1 BID IN ANY CASE.	
4	THE TENDER RECEIVED AFTER 14:00 HRS ON THE DUE DATE WILL NOT BE CONSIDERED.	
5	YOUR TECHNO COMMERCIAL BID SHOULD MENTION THAT PRICE BID HAS BEEN SENT IN A SEPARATE ENVELOPE GIVING ITS REFERENCE.	
6	BID SHOULD BE FREE FROM CORRECTION, OVERWRITING, USING CORRECTIVE FLUID, ETC. ANY INTERLINEATION , CUTTING , ERASURE OR OVERWRITING SHALL BE VALID ONLY IF THEY ARE ATTESTED UNDER FULL SIGNATURE(S) OF PERSON(S) SIGNING THE BID ELSE BID SHALL BE LIABLE FOR REJECTION .	
7	PRICING TERMS: PRICES ONCE QUOTED SHALL REMAIN FIRM WITHIN THE VALIDITY OR ANY EXTENSION THEREOF FOR PLACEMENT OF ORDER, TILL COMPLETE EXECUTION OF THE ORDER, WITHOUT ANY ESCALATION/INCREASE FOR ANY REASON, WHATSOEVER, UNLESS SPECIFICALLY PROVIDED FOR IN THE ENQUIRY & PO. IN CASE OF FOREIGN VENDORS, THE QUOTED PRICE SHALL BE TAKEN AS INCLUSIVE OF THIRD PARTY INSPECTION AND TESTING CHARGES AS CALLED FOR IN THE NIT.	
8	VALIDITY OF OFFER SHOULD BE MINIMUM 120 DAYS FROM THE DATE OF TECHNO - COMMERCIAL BID OPENING OR 60 DAYS FROM THE REVERSE AUCTION DATE.	
9	UNLESS SPECIFIED IN THE TENDER, VENDOR MUST NOTE THAT BHEL WILL ARRIVE THE L1 STATUS FOR EACH ITEM ON LANDED COST BASIS. ACCORDINGLY, ORDER SHALL BE PLACED ON LOWEST BIDDER ON INDIVIDUAL ITEM BASIS ONLY, UNLESS BHEL ASK FOR TERMS OTHER THAN THIS ON EXCEPTION BASIS. IN THE COURSE OF EVALUATION, IF MORE THAN ONE BIDDER HAPPENS TO OCCUPY L-1 STATUS, EFFECTIVE L-1 WILL BE DECIDED BY SOLICITING DISCOUNTS FROM THE RESPECTIVE L-1 BIDDERS. IN CASE MORE THAN ONE BIDDERS HAPPENS TO OCCUPY THE L-1 STATUS EVEN AFTER SOLICITING DISCOUNT, THE L-1 BIDDER SHALL BE DECIDED BY A TOSS/DRAW OF LOTS, IN THE PRESENCE OF THE RESPECTIVE BIDDER(S) OR THEIR REPRESENTATIVE(S). RANKING WILL BE DONE ACCORDINGLY. BHEL'S DECISION IN SUCH SITUATION SHALL BE FINAL AND BINDING.	
10	PLEASE MAKE SURE THAT THERE IS NO DISCREPANCY IN BETWEEN ACCEPTED TERMS & CONDITIONS MENTIONED IN THE CHECK LIST AND QUOTATION SUBMITTED BY VENDOR AND IF FOUND SO THEN THE TERMS & CONDITIONS WHICH ARE BENEFICIAL TO BHEL WOULD ONLY BE CONSIDERED.	
11	VENDOR TO ENSURE THAT ITEM & QUANTITY MENTIONED IN THE OFFERS ARE EXACTLY SAME AS PER ENQUIRY. IF ANY DEVIATION IS THERE PARTY MUST MENTION SPECIFIC HEREWITH OTHERWISE BHEL SHALL CONSIDER THAT ITEM & QUANTITY AS REQUIRED IN ENQUIRY.	
12	BHEL RESERVES THE RIGHT TO REJECT THE OFFER, WHICH IS HAVING DEVIATIONS TO THE TERMS AND CONDITIONS GIVEN IN THE TENDER ENQUIRY.	
13	GST IF APPLICABLE WILL BE PAID EXTRA AGAINST DOCUMENTARY PROOF. THE RATE OF GST SHOULD BE CLEARLY MENTIONED IN THE OFFER.	
14	<p><b>TERMS OF DELIVERY:</b></p> <p><b>I. FOR INDIGENOUS SUPPLIERS:</b> THE TERMS OF DELIVERY SHOULD BE QUOTED ON F.O.R. DESTINATION (BHEL HERP STORES VARANASI) BASIS ONLY (i.e. FREIGHT &amp; INSURANCE ON VENDOR'S ACCOUNT ONLY). IF ANY BIDDER STILL QUOTES OTHER DELIVERY TERM IN PLACE OF BHEL HERP STORES, THEIR OFFER MAY NOT BE CONSIDERED FOR FURTHER PROCESSING. IT MUST BE SPECIFICALLY NOTED.</p> <p><b>II. FOR FOREIGN SUPPLIER:</b> TERMS OF DELIVERY SHOULD BE QUOTED ON CIF JNPT MUMBAI (INDIA) SEA PORT BASIS (i.e. FREIGHT &amp; INSURANCE ON VENDOR'S ACCOUNT UPTO JNPT MUMBAI (INDIA) SEA PORT) OR CFR MUMBAI AIRPORT. HOWEVER FREIGHT CHARGES AS PER BHEL TRANSPORT CONTRACT FROM MUMBAI TO BHEL VARANASI WILL BE LOADED AT THE TIME OF TOTAL LANDED COST CALCULATION FOR EACH ITEM.</p>	
15	IF ANY INDIAN SUPPLIERS ARRANGE SUPPLY FROM FOREIGN PRINCIPLES/WORKS, TERMS OF DELIVERY SHOULD BE QUOTED ON CIF JNPT MUMBAI (INDIA) SEA PORT BASIS ONLY (i.e. FREIGHT & INSURANCE ON VENDOR'S ACCOUNT UPTO JNPT MUMBAI (INDIA) SEA PORT) OR CFR MUMBAI AIRPORT. HOWEVER FREIGHT CHARGES AS PER BHEL TRANSPORT CONTRACT FROM JNPT MUMBAI SEAPORT/MUMBAI AIRPORT TO BHEL VARANASI FOR EACH ITEM WILL BE LOADED AT THE TIME OF TOTAL LANDED COST CALCULATION.	
16	INSURANCE CHARGES SHALL BE TO VENDOR'S ACCOUNT ONLY IF PRICE QUOTED ON BHEL HERP STORES BASIS. IN CASE PRICE QUOTED IS ON CIF JNPT MUMBAI BASIS/ CFR MUMBAI AIRPORT BASIS, INSURANCE UP TO CIF JNPT MUMBAI/ MUMBAI AIRPORT SHALL BE IN VENDOR ACCOUNT.	
17	<p><b>PAYMENT TERMS:</b></p> <p><b>I. FOR MSEs VENDORS:</b> 80 % OF EQUIPMENT COST PLUS 100% TAXES &amp; DUTIES AGAINST SRV WITHIN 45 DAYS THROUGH EFT (ELECTRONIC FUND TRANSFER) FROM THE DATE OF RECEIPT OF MATERIAL AT BHEL. BALANCE 20% OF MATERIAL COST AND E&amp;C CHARGES, IF APPLICABLE WILL BE PAID TO THE PARTY AFTER INSTALLATION AND COMMISSIONING OF THE EQUIPMENT AT BHEL VARANASI AND SUBMISSION OF PBG (PERFORMANCE BANK GUARANTEE). IF ANY SUPPLIER FALLS UNDER NON MSE CATEGORY, THEIR PAYMENT TERM WILL BE CONSIDERED AS NON MSE SUPPLIER PAYMENT WITHOUT ANY INTIMATION.</p> <p><b>II.FOR OTHER SUPPLIERS:</b> 80 % OF EQUIPMENT COST PLUS 100% TAXES &amp; DUTIES AGAINST SRV WITHIN 90 DAYS THROUGH EFT (ELECTRONIC FUND TRANSFER) FROM THE DATE OF RECEIPT OF MATERIAL AT BHEL. BALANCE 20% OF MATERIAL COST AND E&amp;C CHARGES, IF APPLICABLE WILL BE PAID TO THE PARTY AFTER INSTALLATION AND COMMISSIONING OF THE EQUIPMENT AT BHEL VARANASI AND SUBMISSION OF PBG (PERFORMANCE BANK GUARANTEE).</p> <p><b>III.BHEL HERP WILL MAKE PAYMENTS IN TWO PARTS :-</b></p> <p><b>PART-I:</b> BASIC INVOICE VALUE AND ALL OTHER CHARGES (EXCEPT GST AMOUNT) WILL BE PAID AS PER P.O. PAYMENT TERMS.</p> <p><b>PART-II:</b>GST PORTION OF INVOICE VALUE WILL BE PAID ONLY AFTER FULFILLING FOLLOWING CONDITIONS:</p> <p><b>(A)</b>PAYMENT OF GST AMOUNT INTO GOVT.ACCOUNT BY SUPPLIER AGAINST INVOICE RAISED TO BHEL.</p>	



# Bharat Heavy Electricals Limited

## Heavy Equipment Repair Plant (HERP)

Tarna, Shivpur, Varanasi - 221003

	<p>(B) FILING OF GST RETURN WITHIN SCHEDULED DATE.</p> <p>(C) DISPLAY OF GST CREDIT AGAINST BHEL GSTIN NO.09AAACB4146P22C ON GSTN PORTAL.</p> <p><b>NOTE: ADVANCE PAYMENT IS NOT ACCEPTABLE BY BHEL HERP VARANASI IN ANY CASE.</b></p>	
18	<p><b>LOADING OF PAYMENT TERM:</b> IN CASE OF DEVIATION, LOADING OF INTEREST RATE @SBI MCLR RATE + 6% (AS ON PART-1 OPENING DATE) SHALL BE LOADED WHILE ARRIVING AT LANDED COST TO BHEL.</p>	
19	<p><b>IMPORTANT INSTRUCTION FOR MSEs SUPPLIERS:</b></p> <p>I. "MSE SUPPLIERS CAN AVAIL THE INTENDED BENEFITS ONLY IF THEY SUBMIT ALONG WITH OFFER, ATTESTED COPIES OF EITHER EM-II CERTIFICATE HAVING DEEMED VALIDITY (FIVE YEARS FROM THE DATE OF ISSUE OF ACKNOWLEDGEMENT IN EM-II) OR VALID NSIC CERTIFICATE OR EM-II CERTIFICATE ALONG WITH CA CERTIFICATE (FORMAT ENCLOSED AS PER ANNEXURE-1 WHERE DEEMED VALIDITY OF EM-II CERTIFICATE OF FIVE YEARS HAS EXPIRED) APPLICABLE FOR THE RELEVANT F/Y (LATEST AUDITED). DATE TO BE RECKONED FOR DETERMINING THE DEEMED VALIDITY WILL BE THE DATE OF BID OPENING (PART -1 IN CASE OF TWO PART BID). NON SUBMISSION OF SUCH DOCUMENTS WILL LEAD TO CONSIDERATION OF THEIR BID AT PAR WITH OTHER BIDDERS. NO BENEFIT SHALL BE APPLICABLE FOR THIS ENQUIRY IF ANY DEFICIENCY IN THE ABOVE REQUIRED DOCUMENTS ARE NOT SUBMITTED BEFORE PRICE BID OPENING. IF THE TENDER IS TO BE SUBMITTED THROUGH e-procurement PORTAL, THEN THE ABOVE REQUIRED DOCUMENTS ARE TO BE UPLOADED ON THE PORTAL. DOCUMENTS SHOULD BE NOTARIZED OR ATTESTED BY A GAZETTED OFFICE.</p> <p>II. IN CASE OF ANY CHANGE IN THE MSE STATUS OF THE BIDDER, IT SHALL BE RESPONSIBILITY OF THE BIDDER TO NOTIFY THE CHANGE AS A PART OF THE BID DOCUMENT. IF AT A LATER DATE IT COMES TO NOTICE OF BHEL, THAT THE CHANGE IN THE STATUS HAS NOT BEEN INTIMATED BY THE BIDDER AND THE ORDER IS TO BE OBTAINED UNDER THE PREMISE OF AN MSE, THEN BHEL WOULD CANCEL THE PENDING ORDER AGAINST THIS TENDER AND TAKE NECESSARY ACTION SUSPENSION OF THE BUSINESS DEALING WITH THE BIDDER AS PER PROCUREMENT POLICY OF BHEL.</p> <p>III. 25% OF THE TENDERED QUANTITY IS EARMARKED FOR MSE SUPPLIERS IN THIS TENDER.</p> <p>IV. OUT OF THIS 25% TENDERED QUANTITY RESERVED FOR MSE SUPPLIERS, 6.25% SHALL BE EARMARKED FOR PROCUREMENT FROM MSEs OWNED BY SC/ST ENTREPRENEURS.</p> <p>V. OUT OF THIS 25% TENDERED QUANTITY RESERVED FOR MSE SUPPLIERS, 3% SHALL BE EARMARKED FOR PROCUREMENT FROM MSEs OWNED BY WOMEN.</p> <p>VI. IN CASE MSE VENDOR PARTICIPATING IN THE TENDER QUOTES WITHIN THE PRICE BAND OF "L1+15%", THEY WILL BE ALLOWED TO SUPPLY THE 25% PORTION OF THE REQUIREMENT SUBJECT TO ACCEPTANCE OF L1 PRICE (ON LANDED COST BASIS) BY MSE VENDOR. IN CASE OF MORE THAN ONE SUCH MSE VENDOR WITHIN THE "L1+15% PRICE BAND" THE SUPPLY SHALL BE SHARED PROPORTIONATELY (TO 25% TENDERED QUANTITY).</p> <p>VII. IF THE L1 VENDOR HAPPENS TO BE A MSE VENDOR AGAINST ANY ITEM CODE, THEN 100% OF THE TENDERED QTY (FOR RESPECTIVE ITEM CODE) SHALL BE PROPOSED TO ORDER ON THE L1 (MSE) VENDOR, EVEN THOUGH THERE MAY BE OTHER MSE VENDORS WITHIN THE "L1+15% PRICE BAND".</p> <p>VIII. IN CASE AFTER OPENING OF PRICE BID, IT IS SEEN THAT NO MSE HAS BECOME L1, THEN DEPENDING ON THE NATURE OF THE ITEM, IF IT IS NOT POSSIBLE TO SPLIT THE TENDERED ITEMS/QUANTITIES ON ACCOUNT OF REASONS LIKE CUSTOMER CONTRACT REQUIREMENTS OF SUPPLYING ONE MAKE FOR A GIVEN PROJECT OR TECHNICAL REASONS LIKE TENDERED ITEMS BEING A SYSTEM etc. THEN BHEL WOULD NOT COUNTER OFFER THE L1 PRICES EVEN THOUGH THERE MAY BE MSE BIDDERS WITHIN THE "L1+15% PRICE BAND" OF L1.</p>	
20	<p><b>LIQUIDATED DAMAGES (LD):</b> SUBJECT TO FORCE MAJEURE CONDITIONS, FAILURE TO SUPPLY WITHIN PURCHASE ORDER DELIVERY SCHEDULE WILL MAKE THE SUPPLIER LIABLE TO AN UNCONDITIONAL PENALTY OF 0.5 % PER WEEK OR PART THEREOF SUBJECT TO THE MAXIMUM OF 10% OF THE UNDELIVERED PURCHASE ORDER VALUE EXCLUDING TAXES &amp; DUTIES. NO GRACE PERIOD SHALL BE GIVEN. FURTHER, IN CASE OF LD RECOVERY, THE APPLICABLE GST SHALL ALSO BE RECOVERABLE FROM THE SUPPLIERS. <b>(GST RECOVERY ON LD IS NOT APPLICABLE FOR FOREIGN VENDORS)</b>.</p>	
21	<p><b>LOADING OF LIQUIDATED DAMAGES (LD):</b> DEVIATION TO ABOVE STANDARD PENALTY CLAUSE, MAXIMUM LOADING OF 10% (IN CASE OF NON ACCEPTANCE OF LD CLAUSE) OR PART THEREOF (IN CASE OF PART ACCEPTANCE OF LD) SHALL BE LOADED WHILE ARRIVING LANDED COST TO BHEL.</p> <p>FURTHER IF DEVIATION IS FOUND IN THE ACCEPTED DELIVERY TERM AS WELL AS ACCEPTED PENALTY TERM, SUITABLE LOADING BASED ON TRANSPORTATION TIME TO BE TAKEN SHALL BE LOADED WHILE ARRIVING LANDED COST TO BHEL HERP STORES WHICH MAY BE AS BELOW:</p> <p>(i) 1% OF THE BASIC COST FOR INDIAN SUPPLIERS,</p> <p>(ii) 2% OF THE BASIC COST IF FOREIGN VENDOR ACCEPTS PENALTY FROM BILL OF LADING DATE &amp;</p> <p>(iii) 3% OF THE BASIC COST IF FOREIGN VENDOR ACCEPTS PENALTY FROM THE INSPECTION DATE.</p>	
22	<p><b>DELIVERY PERIOD:</b> DELIVERY PERIOD FOR ALL THE ITEMS SHALL BE <b>06 MONTH</b> FROM THE DATE OF PURCHASE ORDER.</p>	
23	<p>IF ANY VENDOR DOES NOT SUPPLY THE ITEM WITHIN THE PURCHASE ORDER DELIVERY PERIOD, BHEL MAY/MAY NOT ACCEPT THE SUPPLY AT ITS SOLE DISCRETION.</p>	
24	<p><b>REVERSE AUCTION:</b> BHEL SHALL BE RESORTING TO REVERSE AUCTION (RA) (GUIDELINES AS AVAILABLE ON <a href="http://www.bhel.com">WWW.BHEL.COM</a>) FOR THIS TENDER. RA SHALL BE CONDUCTED AMONG ALL THE TECHNO-COMMERCIALY QUALIFIED BIDDERS.</p> <p>PRICE BIDS OF ALL TECHNO-COMMERCIALY QUALIFIED BIDDERS SHALL BE OPENED AND SAME SHALL BE CONSIDERED AS INITIAL BIDS OF BIDDERS IN RA. IN CASE ANY BIDDER(S) DO (ES) NOT PARTICIPATE IN ONLINE REVERSE AUCTION, THEIR SEALED ENVELOPE PRICE BID ALONG WITH APPLICABLE LOADING, IF ANY, SHALL BE CONSIDERED FOR RANKING.</p>	
25	<p>IF ANY OF THE VENDORS DO NOT ACCEPT THE ABOVE POINT MENTIONED AT SL. NO. 24, THEIR OFFER MAY BE LIABLE FOR REJECTION WITHOUT INTIMATION.</p>	
26	<p><b>RISK PURCHASE:</b> IN CASE OF DELAY IN SUPPLIES/ DEFECTIVE SUPPLIES/NON EXECUTION OF PURCHASE ORDER ETC. (FOR DETAILS, REFER GUIDELINES FOR RISK PURCHASE), BHEL MAY CANCEL THE ORDER IN FULL OR PART THEREOF/ MAY ALSO MAKE THE PURCHASE OF SUCH MATERIALS FROM ELSEWHERE/ALTERNATIVE SOURCES AT THE RISK &amp; COST OF SUPPLIER. BHEL MAY ALSO MANUFACTURE THE ITEM IN-HOUSE IN PART OR FULL DEPENDING UPON THE URGENCY OF THE ITEM.</p> <p>GUIDELINES FOR <b>RISK PURCHASE</b> IS AVAILABLE ON BHEL WEBSITE "<a href="https://herp.bhel.com">https://herp.bhel.com</a>" at "<b>Notice</b>". RESPECTIVE BIDDERS / SUPPLIERS MAY REFER THIS GUIDELINE BEFORE SUBMITTING THEIR OFFER AGAINST BHEL, HERP TENDER ENQUIRIES. IN CASE RISK PURCHASE IS APPLIED, BHEL SHALL TAKE ACTION AGAINST THE NON-PERFORMING AND/OR DEFAULTING SUPPLIERS/ CONTRACTORS IN LINE WITH THIS GUIDELINE ONLY.</p>	
27	<p>BHEL MAY SHORT CLOSE/CANCEL AN ORDER AT ANY TIME DURING THE CURRENCY OF THE CONTRACT/PO IRRESPECTIVE OF THE PO DELIVERY DATE, IF</p> <p>(I) THE WORK PROGRESS OF THE VENDOR IS POOR, OR</p> <p>(II) THE DELIVERY REQUIREMENT OF THE ITEM IS VERY CRITICAL &amp; NOT BEING MET BY THE VENDOR ON WHICH ORDER HAS BEEN PLACED, OR</p> <p>(III) THERE IS NO RESPONSE FOR IMPROVEMENT IN DELIVERY AS PER BHEL REQUIREMENT,</p>	
28	<p>THE OFFERS OF THE BIDDERS WHO ARE ON THE BANNED LIST AND ALSO THE OFFER OF THE BIDDERS, WHO ENGAGE THE SERVICES OF THE BANNED FIRMS, SHALL BE REJECTED. THE LIST OF BANNED FIRMS IS AVAILABLE ON BHEL WEB SITE <a href="http://www.bhel.com">www.bhel.com</a></p>	
29	<p><b>RESERVATION RIGHTS OF BHEL:</b> - BHEL RESERVES THE RIGHT TO REJECT ANY OR ALL QUOTATIONS WITHOUT ASSIGNING ANY REASONS THEREOF. BHEL ALSO RESERVES THE RIGHT TO INCREASE OR DECREASE THE TENDERED QUANTITIES. VENDORS SHOULD BE PREPARED TO ACCEPT ORDER FOR REDUCED QUANTITIES WITHOUT ANY EXTRA CHARGES. VENDOR SHOULD ALSO BE PREPARED FOR GIVING DISCOUNT IN CASE OF INCREASE IN QUANTITY.</p>	
30	<p><b>NON-DISCLOSURE AGREEMENT:</b> ALL DRAWINGS AND STANDARDS ARE PROPRIETARY OF BHEL. IT MUST NOT BE USED IN ANY WAY DETRIMENTAL TO THE INTEREST OF THE COMPANY. ALL SUPPLIERS SHALL FURNISH NDAS (NON-DISCLOSURE AGREEMENT) AGAINST USE OF DOCUMENTS FURNISHED BY BHEL TOWARDS UN-AUTHORIZED USE EXCEPT FOR THE PURPOSE IT HAS BEEN FURNISHED.</p>	
31	<p><b>A. SETTLEMENT OF DISPUTES &amp; ARBITRATION:</b></p>	



# Bharat Heavy Electricals Limited

## Heavy Equipment Repair Plant (HERP)

**Tarna, Shivpur, Varanasi - 221003**

	<p>I. ALL QUESTIONS/INTERPRETATIONS REGARDING SUBJECT MATTER OF THE CONTRACT SHALL BE DECIDED BY THE BHEL ON THE REQUEST OF THE VENDOR AND THE DECISION OF THE BHEL SHALL BE FINAL.</p> <p>II. IN CASE OF DISPUTE, STEPS SHALL BE TAKEN BY THE PARTIES TO THE CONTRACT TO SETTLE THE SAME THROUGH NEGOTIATIONS.</p> <p>III. IN CASE, DISPUTE IS NOT SETTLED IN NEGOTIATIONS, IT SHALL BE REFERRED TO CONCILIATOR APPOINTED BY THE COMPETENT AUTHORITY OF THE BHEL. THE CONCILIATION PROCEEDINGS WITH RESPECT TO A DISPUTE AS DEFINED IN THE BHEL CONCILIATION SCHEME, 2018 AND SUBSEQUENT REVISIONS CAN BE INITIATED UNDER THE SCHEME AT ANY STAGE WHETHER BEFORE, DURING OR EVEN AFTER THE COMMENCEMENT OF ARBITRATION PROCEEDINGS OR LITIGATION BEFORE COURTS. THIS CONCILIATION SCHEME IS AVAILABLE ON OUR WEBSITES <a href="https://herp.bhel.com">https://herp.bhel.com</a> AND <a href="http://WWW.BHEL.COM">WWW.BHEL.COM</a>.</p> <p>IV. IN CASE DISPUTE IS NOT SETTLED IN CONCILIATION PROCEEDINGS, THE SAME SHALL BE REFERRED TO ARBITRATION AS PER CORPORATE GUIDELINES OF THE BHEL AND THE ARBITRATION PROCEEDING SHALL BE CONDUCTED AS PER PROVISIONS OF THE ARBITRATION AND CONCILIATION ACT, 1996 READ WITH CORPORATE GUIDELINE AS AMENDED FROM TIME TO TIME.</p> <p>V. THE VENDOR SHALL CONTINUE TO PERFORM THE CONTRACT, PENDING SETTLEMENT OF DISPUTE(S).</p> <p><b>B. JURISDICTION:</b> ALL DISPUTES OR DIFFERENCES ARISING OUT OF OR IN CONNECTIONS WITH THE CONTRACT SHALL BE SUBJECT TO THE EXCLUSIVE JURISDICTION OF THE COURT AT VARANASI (U.P.) ONLY.</p>	
32	<p><b>SPECIAL NOTE FOR BIDDERS:</b> THE QUOTATION SHOULD BE FROM PRINCIPAL / ORIGINAL EQUIPMENT MANUFACTURER ONLY. THE OFFER OF THOSE OEM, AUTHORISING THEIR TRADER / DEALER / DISTRIBUTOR TO QUOTE AND TAKE ORDER IS LIABLE FOR DISQUALIFICATION. SINCE BHEL PREFER TO DEAL DIRECTLY WITH OEM AND NOT THROUGH DEALER / TRADER / DISTRIBUTOR OF OEM, THEREFORE, OEM MUST DIRECTLY QUOTE, TAKE ORDER AND DELIVER THE MATERIAL UNDER THEIR GUARANTEE / WARRANTEE.</p>	
33	<p><b>THE EVALUATION OF CURRENCY FOR THIS TENDER SHALL BE INR.</b> FOR EVALUATION, EXCHANGE RATE (TT SELLING RATE OF SBI) AS ON SCHEDULED DATE OF TENDER OPENING (PART-1 BID IN CASE OF TWO PART BID) SHALL BE CONSIDERED.</p>	
34	<p><b>GUIDELINES REGARDING DEALINGS WITH INDIAN AGENTS OF FOREIGN SUPPLIERS (IF APPLICABLE):</b> - BHEL SHALL DEAL DIRECTLY WITH THE FOREIGN ORIGINAL EQUIPMENT MANUFACTURERS (OEM) / FOREIGN PRINCIPAL, FOR ALL ITS PURCHASES WHICH ARE IMPORTED. WHEREVER THE FOREIGN OEM / PRINCIPAL DESIRES TO AVAIL THE SERVICES OF AN INDIAN AGENT, THE DEALINGS WITH INDIAN AGENT ARE TO BE REGULATED. THE GUIDELINES OF BHEL IN THIS REGARD HAVE BEEN DRAFTED AS PER ANNEXURE – III, ANNEXURE A &amp; ANNEXURE B ATTACHED ALONG WITH THIS ENQUIRY. FOREIGN OEM / PRINCIPAL SHOULD ENSURE COMPLIANCE TO THESE REGULATORY GUIDELINES WITH DOCUMENTARY EVIDENCE &amp; CONFIRM THEIR ACCEPTANCE.</p>	
35	<p>ALL THE NECESSARY DOCUMENTS REQUIRED AS PER ANNEXURE B (PART B) HAS BEEN ENCLOSED ALONG WITH THE TECHNO-COMMERCIAL BID (FOR FOREIGN VENDORS ONLY).</p>	
36	<p>IN A TENDER, EITHER THE INDIAN AGENT ON BEHALF OF THE PRINCIPAL/OEM OR PRINCIPAL/OEM ITSELF CAN BID BUT BOTH CANNOT BID SIMULTANEOUSLY FOR THE SAME ITEM/PRODUCT IN THE SAME TENDER. IN CASE BIDS ARE RECEIVED FROM BOTH, I.E. PRINCIPAL (OEM) AND THE AGENT, BID RECEIVED FROM THE AGENT WILL BE IGNORED.</p>	
37	<p><b>INSPECTION CHARGES FOR FOREIGN BIDDERS:</b> INSPECTION SHALL BE DONE BY M/S LLOYDS/TUV/BV ONLY OR AS MENTIONED IN THE ENQUIRY AND SAME WILL BE ARRANGED BY THE PARTY ON ITS OWN COST ONLY.</p>	
38	<p>FOREIGN VENDORS MUST SUBMIT THE OFFER AS WELL ANY CLARIFICATIONS, IN ENGLISH LANGUAGE ONLY.</p>	
39	<p><b>(A) FOR INDIAN SUPPLIERS:</b> I. FOLLOWING DOCUMENTS SHOULD BE ENCLOSED AND ADDRESSED TO DGM (FINANCE) AND SAME SHALL BE DISPATCHED TO MM DEPTT. BHEL, HERP, TARNA, SHIVPUR, VARANASI-221003 FOR PAYMENT PURPOSE:</p> <ol style="list-style-type: none"> <li>05 (FIVE) COPIES OF GST INVOICES</li> <li>COPY OF GR/RR.</li> <li>TEST CERTIFICATE AND GUARANTEE/WARRANTEE CERTIFICATE AND PDI REPORT, IF APPLICABLE. (ONE COPY).</li> </ol> <p>II. FURTHER TO ABOVE, 02 (TWO) COMPLETE SETS OF DOCUMENTS (COPIES OF ABOVE MENTIONED DOCUMENTS AT SL. NO. I FOR INDIAN SUPPLIERS (UNDER THIS CLAUSE) SHALL BE SENT FOR PURCHASE AND QUALITY DEPARTMENTS. ORIGINAL COPIES OF TC, GC, PDI REPORTS &amp; OTHER QUALITY PAPERS SHALL BE ATTACHED IN THE SET OF DOCUMENTS FOR QUALITY DEPARTMENTS.</p> <p><b>(B) FOR FOREIGN SUPPLIERS:</b> DOCUMENTS SHALL BE ROUTED FOR PAYMENT AS WELL AS CUSTOM CLEARANCE AS PER BELOW DETAILS:</p> <p>I. FOLLOWING MENTIONED DOCUMENTS SHOULD BE ROUTED TO THE BANK AGAINST LC /BANK PAYMENT:</p> <ol style="list-style-type: none"> <li>ORIGINAL INVOICES.</li> <li>ORIGINAL COPY OF BILL OF LADING OR AIR WAY BILL.</li> <li>TEST CERTIFICATE AND GUARANTEE/WARRANTEE CERTIFICATE AND PDI REPORT, IF APPLICABLE. (ONE COPY).</li> <li>PACKING LIST.</li> <li>OTHER CERTIFICATES/PAPERS AS REQUIRED IN PURCHASE ORDER.</li> </ol> <p>II. ONE SET OF NON - NEGOTIABLE' DOCUMENTS INCLUDING COPY BILL OF LADING / AIR WAY BILL, INVOICE, PACKING LIST, TEST CERTIFICATE, GUARANTEE CERTIFICATE, PDI REPORT (AS APPLICABLE) etc. TO BE SENT TO GENERAL MANAGER, BHARAT HEAVY ELECTRICLAS LIMITED – REGIONAL OPERATION DIVISION, 14 /15th FLOOR), WORLD TRADE CENTRE-1, CUFFE PARADE, MUMBAI - 400005 (INDIA).</p> <p>III. ONE SET EACH OF NON - NEGOTIABLE' DOCUMENTS INCLUDING COPY BILL OF LADING / AIR WAY BILL, INVOICE, PACKING LIST, TEST CERTIFICATE, GUARANTEE CERTIFICATE, PDI REPORT (AS APPLICABLE) etc. TO BE SENT TO SDGM (MM) &amp; AGM (FINANCE), BHARAT HEAVY ELECTRICLAS LIMITED, HEAVY EQUIPMENT REPAIR PLANT, TARNA, SHIVPUR, VARANASI (INDIA) – 221003 THROUGH COURIER/POST.</p> <p><b>(C) BHEL SHALL SEEK CLARIFICATION(S) (IF ANY) RELATED TO PAYMENT DOCUMENTS IN ONE GO. THE VENDOR SHOULD PROVIDE ALL SUCH CLARIFICATION(S) IMMEDIETLY. ANY DELAY IN PROCESSING OF PAYMENT, DUE TO NON RECEIPT OF CLARIFICATION(S) SOUGHT BY BHEL, SHALL BE ATTRIBUTABLE COMPLETELY TO VENDOR.</b></p>	
40	<p><b>GUIDELINES FOR SUSPENSION OF BUSINESS DEALINGS WITH SUPPLIERS/ CONTRACTORS:</b> THE REVISED GUIDELINES FOR SUSPENSION OF BUSSINESS DEALINGS ARE AVAILABLE ON BHEL WEBSITE AT "www.bhel.com" on "SUPPLIER REGISTRATION PAGE". RESPECTIVE BIDDERS / SUPPLIERS MAY REFER THIS BEFORE QUOTING AS PER THEIR REQUIREMENT. ACTION AGAINST THE DEFAULTED SUPPLIERS/ CONTRACTORS' SHALL BE TAKEN AS PER THESE GUIDELINES ONLY.</p>	
41	<p>IF BHEL ISSUES FREE ISSUE MATERIALS TO THE SUPPLIER, IT MUST BE RETURNED WITHIN THE TIME LIMIT AS PRESCRIBED IN GST LAW (PRESENTLY 01 (ONE) YEAR FROM THE DATE OF FREE ISSUE DATE) TO COMPLY THE GST RULES. IF ANY VENDOR DOES NOT RETURN THE BHEL FREE ISSUE MATERIALS AS MENTIONED ABOVE, THE FINANCIAL IMPLICATION ON ACCOUNT OF THIS, IF ANY, SHALL BE RECOVERED FROM THE PARTY BILLS.</p>	
42	<p>TRANSPORTATION CHARGES FOR SENDING BHEL FREE ISSUE MATERIALS TO THE PARTY WORKS WILL BE BORNE BY BHEL ONLY.</p>	



# Bharat Heavy Electricals Limited

## Heavy Equipment Repair Plant (HERP)

**Tarna, Shivpur, Varanasi - 221003**

43	<p><b>BANK GUARANTEE:</b> THE COST OF BHEL FREE ISSUE MATERIALS PER SET/PER ASSEMBLY WILL BE APPROX. RS. ----- WHERE AS TOTAL COST OF FIM VALUE FOR ENQUIRY IS RS. -----.</p> <p>1. PARTY WILL HAVE TO SUBMIT EQUAL AMOUNT OF SECURITY DEPOSIT (IN THE FORM OF 25% BG/FDR/DD/CHEQUE/BANK TRANSFER AND 75% INDEMNITY BOND) TOWARDS THE COST OF BHEL MATERIALS TO BE ISSUED TO THEM BEFORE THE ISSUE OF BHEL MATERIALS TO THEM. AT ANY POINT OF TIME, PROPORTIONATE SECURITY DEPOSIT OF TOTAL/CUMMULATIVE MATERIAL VALUE SHOULD BE MAINTENED.</p> <p>2. BHEL MAY ASK THE SUPPLIER FOR SUBMISSION OF FULL SECURITY DEPOSIT AMOUNT OR PART DEPENDING UPON THE AVAILABILITY OF FREE ISSUE MATERIALS AT OUR END.</p> <p>3. PARTY MUST HAVE TO SUBMIT THE SAME WITHIN 02 WEEK TIME FROM THE DATE OF WRITTEN INTIMATION BY BHEL WITHOUT FAIL OTHERWISE IT WOULD TREATED AS FAILURE OF HONOURING PO TERMS AND ACCORDINGLY BHEL MAY CANCEL THE PURCHASE ORDER AND INITIATE ALTERNATE PROCUREMENT ACTION AT SUPPLIER RISK &amp; COST.</p> <p>4. IN CASE OF ABSENCE OF DESIRED SECURITY DEPOSIT AT BHEL END AND ALSO NON RESPONSE OF POINT NO. 03 AS ABOVE,</p> <p>I. BHEL MAY HOLD THE PENDING PAYMENTS OF SUPPLIER AVAILABLE AT BHEL END WITHOUT ANY INTIMATION.</p> <p>II. IF NO PAYMENT IS PENDING AT BHEL END, ACTION FOR ALTERNATE PROCUREMENT ACTION MAY BE INITIATED.</p>	
44	VENDOR MUST FOLLOW THE SEQUENTIAL DELIVERY SCHEDULE i.e. ITEMS TO BE SUPPLIED IN SUCH A MANNER THAT THE PURCHASE ORDER HAVING OLDER DELIVERY SCHEDULE SHOULD BE SUPPLIED EARLIER AND PURCHASE ORDER HAVING LATTER DELIVERY SCHEDULE TO BE SUPPLIED LATTER. IF ANY VENDOR DOES NOT FOLLOW THE SEQUENTIAL DELIVERY SCHEDULE ESPECIALLY FOR SAME ITEM, BHEL MAY ACCOUNT FOR THE ITEM IN SEQUENTIAL MANNER OR MAY RECOVER THE FINANCIAL IMPLICATION.	
45	VENDOR MUST VISIT OUR WEBSITE <a href="https://herp.bhel.com">https://herp.bhel.com</a> REGULARLY FOR ENQUIRY/PO/CLARIFICATIONS/FOR ANY LATEST UPDATES.	
46	ALL ABOVE ACCEPTED TERMS & CONDITIONS SHALL BE PART OF PURCHASE ORDER WITH OR WITHOUT MENTIONING IN THE PO/CONTRACT BASED ON YOUR ACCEPTANCE AND OFFER SUBMITTED.	
47	THE BIDDER ALONG WITH ITS ASSOCIATE/COLLABORATORS/SUB-CONTRACTORS/SUB-VENDORS/CONSULTANTS/SERVICE PROVIDERS SHALL STRICTLY ADHERE TO BHEL FRAUD PREVENTION POLICY DISPLAYED ON THE BHEL WEBSITE <a href="http://www.bhel.com">http://www.bhel.com</a> and <a href="https://herp.bhel.com">https://herp.bhel.com</a> AND SHALL IMMEDIATELY BRING TO THE NOTICE OF BHEL MANAGEMENT ABOUT ANY FRAUD OR SUSPECTED FRAUD AS SOON AS IT COMES TO THEIR NOTICE.	
48	<p><b>IMPORTANT INSTRUCTION:</b></p> <p>I.VENDORS ARE REQUESTED TO QUOTE THEIR RATE WITH DESCRIPTION MENTIONED IN THE ENQUIRY CONSIDERING ALL TECHNICAL TERMS &amp; CONDITIONS OF THE ENQUIRY. ALSO RATES QUOTED SHOULD BE EXACTLY AS PER SL. NO. OF HARD COPY OF THE ENQUIRY (IF ENQUIRY HAS BEEN FLOATED THROUGH CONVENTIONAL MODE) OR AS PER SL. NO. APPEARING IN THE e-Procurement PORTAL (IF ENQUIRY HAS BEEN FLOATED THROUGH e-Procurement) ONLY. IT MUST BE FOLLOWED UP TO AVOID CONFUSION AT LATER STAGES. ALSO RATES TO BE SUBMITTED BOTH IN NUMERICS AS WELL AS IN WORD. IN CASE OF DISCREPANCY, RATES SUBMITTED IN WORDS SHALL BE CONSIDERED FOR FURTHER PROCESSING.</p> <p>II.DOCUMENTS SUBMITTED WITH THE OFFER SHOULD BE SIGNED AND STAMPED IN EACH PAGE BY AUTHORIZED REPRESENTATIVE OF THE BIDDER.</p> <p>II.IN CASE OF PDI, VENDOR SHALL RAISE ONLINE INSPECTION CALL IN ONLINE INSPECTION PORTAL/INTIMATE BHEL IN WRITTING (WHERE INSPECTION IS IN BHEL HERP SCOPE) AT LEAST 01 WEEK IN ADVANCE OR AS MUTUALLY AGREED PERIOD ABOUT THE DATE AND PLACE AT WHICH GOODS WILL BE READY FOR INSPECTION.</p> <p>IV.PURCHASER OR HIS AUTHORIZED REPRESENTATIVE SHALL BE ENTITLED TO CARRY OUT SURVEILLANCE INSPECTION OF MATERIAL AND WORKMANSHIP AT SELLER'S PREMISES OR AT HIS SUB-CONTRACTOR'S PREMISES AT ALL REASONABLE TIMES DURING EXECUTION OF THE CONTRACT. SUCH INSPECTION, EXAMINATION AND TESTING, IF MADE, SHALL NOT ABSOLVE THE SELLER FROM HIS OBLIGATIONS UNDER THE CONTRACT.</p> <p>V.SUCH PRE-DISPATCH INSPECTION, EXAMINATION AND TESTING, IF MADE, AT VENDOR'S WORKS SHALL NOT ABSOLVE THE SELLER FROM HIS OBLIGATIONS TO MANUFACTURE/MACHINING THE GOODS UNDER THE CONTRACT. IF DEFECTS ARE FOUND AT LATER STAGE, IT IS THE SOLE RESPONSIBILITY OF THE VENDOR TO REPLACE/RECTIFY THE SAME.</p>	
49	<p><b>FOREIGN VENDORS MUST TAKE CARE WHILE BOOKING THE CONSIGNMENT ON CIF BASIS:</b></p> <p>I.THE INVOICES BEING ISSUED BY SHIPPING LINES MUST BE IN THE NAME OF BHARAT HEAVY ELECTRICLAS LIMITED, HEAVY EQUIPMENT REPAIR PLANT, VARANASI, UTTAR PRADESH, INDIA.</p> <p>II.WHILE BOOKING THE SHIPMENT, VENDOR SHOULD ALSO FINALIZE DESTINATION CHARGES AND THE SAME SHOULD BE CONVEYED TO BHARAT HEAVY ELECTRICLAS LIMITED – REGIONAL OPERATION DIVISION, MUMBAI OFFICE OR BHARAT HEAVY ELECTRICLAS LIMITED, HEAVY EQUIPMENT REPAIR PLANT, VARANASI BEFORE THE CONSIGNMENT REACHES THE DESTINATION PORT.</p> <p>III.IF CARGO IS STUFFED IN CONTAINER THEN THE SAME SHOULD BE ALLOWED TO BE MOVED TO CONTAINER FREIGHT STATIONS (CFS) OF IMPORTERS CHARGE WITHOUT ANY ADDITIONAL CHARGES.</p> <p>IV.LOAD PORT CHARGES SHOULD BE SETTLED BY THE VENDOR AND SHOULD NOT BE PASSED ON TO BHEL IN SOME FORM OF DESTINATION CHARGES.</p> <p>V.SUPPLIERS MUST PROVIDE 14 DAYS FREE DETENTION FROM THE DATE OF DELIVERY AT DELIVERY PORT. WHEREEVER DETENTION FREE PERIOD OFFERED IS LESS THAT 14 DAYS, THE BIDS SHALL BE LOADED FOR THE PERIOD SHORT OF 14 DAYS PERIOD. IF IT NOT MENTIONED AT OFFER STAGE, IT WOULD BE CONSIDERED AS 14 DAYS ONLY.</p> <p>VI.PORT CONGESTION CHARGES OR ANY ADDITIONAL CHARGES CLAIMED BY SHIPPING LINE TILL DELIVERY AT DESTINATION PORT SHALL BE TO THE SELLER'S ACCOUNT.</p>	
50	<p><b>IMPORTANT CLAUSE FOR GST:</b> INPUT TAX CREDIT OF GST CAN BE AVAILED BY BHEL ONLY WHEN THE MATERIAL HAS BEEN PHYSICALLY RECEIVED AND GST INVOICE IS IN POSSESSION OF BHEL. THEREFORE, SUPPLIERS SHOULD ENSURE THE FOLLOWING IN RESPECT OF POS ISSUED BY BHEL:</p> <p>I. GST INVOICE SHOULD CONTAIN ADDRESS, GST NO. AND PAN NO. OF BHEL AS WELL AS OF SUPPLIER. APPLICABLE HSN CODE OF THE MATERIAL SHOULD BE INDICATED IN THE GST INVOICE.</p> <p>II. FIVE COPIES OF GST INVOICE AND LORRY RECEIPT MAY BE DESPATCHED ALONGWITH SHIPMENT OF THE GOODS IN ORDER TO AVOID ANY DELAY IN AVAILING INPUT CREDIT BY BHEL.</p> <p>III. DECLARE SUCH INVOICE IN HIS GSTR-1 RETURN FOR THE MONTH OF DESPATCH OF MATERIAL.</p> <p>IV. PAYMENT OF GST TO STATUTORY AUTHORITIES WITHIN PRESCRIBED TIME.</p> <p>IN CASE GST CREDIT IS DELAYED /DENIED TO BHEL DUE TO NON OR DELAYED RECEIPT OF GOODS AND OR TAX INVOICE OR EXPIRY OF TIMELINE PRESCRIBED IN GST LAW FOR AVAILING SUCH ITC OR ANY OTHER REASON NOT ATTRIBUTABLE TO BHEL, GST AMOUNT SHALL BE RECOVERABLE FROM VENDOR ALONG WITH INTEREST /PENALTY LEVIABLE ON BHEL.</p> <p>IN CASE SUPPLIERS DELAYS DECLARING SUCH INVOICE IN HIS RETURN AND GST CREDIT AVAILED BY BHEL IS DENIED OR REVERSED SUBSEQUENTLY AS PER GST LAW, GST AMOUNT PAID BY BHEL TOWARDS SUCH ITC REVERSAL SHALL BE RECOVERABLE FROM SUPPLIER ALONGWITH INTEREST LEVIED/LEVIABLE ON BHEL.</p> <p>IN CASE OF RAISING ANY SUPPLEMENTARY TAX INVOICE (DEBIT/ CREDIT NOTE), THE SUPPLIER SHALL ISSUE THE SAME CONTAINING ALL THE DETAILS AS REFERRED TO IN SECTION 34 READ WITH SECTION 31 OF GST ACT &amp; RULES REFERRED THERE UNDER .</p>	
51	<p><b>STATUTORY VARIATION CLAUSE :</b>1.ANY INCREASE IN THE RATE OF GST SHALL BE PAYABLE ONLY FOR DELIVERIES COMPLETED WITHIN THE SCHEDULED DELIVERY PERIOD, IN OTHER WORDS INCREASE IN THE RATE OF GST SHALL NOT BE PAYABLE FOR VALUE OF CONSIGNMENT DELIVERED AFTER THE SCHEDULED PURCHASE ORDER DELIVERY PERIOD.2.NEW TAXES AND DUTIES , IF IMPOSED SUBSEQUENT TO DUE DATE OF OFFER SUBMISSION, BY STATUTORY AUTHORITY DURING CONTRACT PERIOD (INCLUDING EXTENSION IF THE SAME IS NOT ATTRIBUTABLE TO BIDDER) SHALL BE REIMBURSED BY BHEL ON</p>	



# Bharat Heavy Electricals Limited

## Heavy Equipment Repair Plant (HERP)

Tarna, Shivpur, Varanasi - 221003

	<p>PRODUCTION OF RELEVANT SUPPORTING DOCUMENTS TO THE SATISFACTION OF BHEL . HOWEVER, BIDDER SHALL TAKE PRIOR APPROVAL OF BHEL BEFORE DEPOSITING NEW TAXES AND DUTIES.</p>	
52	<p><b>PURCHASE PREFERENCE FOR INDIAN VENDORS:</b> PURCHASE PREFERENCE FOR INDIAN VENDORS: FOR THIS PROCUREMENT, THE LOCAL CONTENT TO CATEGORIZE A SUPPLIER AS A CLASS I LOCAL SUPPLIER / CLASS II LOCAL SUPPLIER /NON LOCAL – SUPPLIER AND PURCHASE PREFERENCE TO CLASS I LOCAL SUPPLIER, IS AS DEFINED IN PUBLIC PROCUREMENT (PREFERENCE TO MAKE IN INDIA), ORDER 2017 DATED 04.06.2020 ISSUED BY DPIIT. IN CASE OF SUBSEQUENT ORDERS ISSUED BY THE NODAL MINISTRY, CHANGING THE DEFINITION OF LOCAL CONTENT FOR THE ITEMS OF THE NIT, THE SAME SHALL BE APPLICABLE EVEN IF ISSUED AFTER ISSUE OF THIS NIT, BUT BEFORE OPENING OF PART –II BIDS AGAINST THIS NIT.</p> <p><b>MODEL CLAUSE FOR TENDER.</b></p> <p>I. ANY BIDDER FROM A COUNTRY WHICH SHARES A LAND BORDER WITH INDIA WILL BE ELIGIBLE TO BID IN THIS TENDER ONLY IF THE BIDDER IS REGISTERED WITH THE COMPETENT AUTHORITY.</p> <p>II. "BIDDER" (INCLUDING THE TERM 'TENDERER', 'CONSULTANT' OR 'SERVICE PROVIDER' IN CERTAIN CONTEXTS) MEANS ANY PERSON OR FIRM OR COMPANY, INCLUDING ANY MEMBER OF A CONSORTIUM OR JOINT VENTURE (THAT IS AN ASSOCIATION OF SEVERAL PERSONS, OR FIRMS OR COMPANIES), EVERY ARTIFICIAL JURIDICAL PERSON NOT FALLING IN ANY OF THE DESCRIPTIONS OF BIDDERS STATED HEREINBEFORE, INCLUDING ANY AGENCY BRANCH OR OFFICE CONTROLLED BY SUCH PERSON, PARTICIPATING IN A PROCUREMENT PROCESS.</p> <p>III. "BIDDER FROM A COUNTRY WHICH SHARES A LAND BORDER WITH INDIA" FOR THE PURPOSE OF THIS ORDER MEANS: -</p> <p>a) AN ENTITY INCORPORATED, ESTABLISHED OR REGISTERED IN SUCH A COUNTRY; OR</p> <p>b) A SUBSIDIARY OF AN ENTITY INCORPORATED, ESTABLISHED OR REGISTERED IN SUCH A COUNTRY; OR</p> <p>c) AN ENTITY SUBSTANTIALLY CONTROLLED THROUGH ENTITIES INCORPORATED, ESTABLISHED OR REGISTERED IN SUCH A COUNTRY; OR</p> <p>d) AN ENTITY WHOSE BENEFICIAL OWNER IS SITUATED IN SUCH A COUNTRY; OR</p> <p>e) AN INDIAN (OR OTHER) AGENT OF SUCH AN ENTITY; OR</p> <p>f) A NATURAL PERSON WHO IS A CITIZEN OF SUCH A COUNTRY; OR</p> <p>g) A CONSORTIUM OR JOINT VENTURE WHERE ANY MEMBER OF THE CONSORTIUM OR JOINT VENTURE FALLS UNDER ANY OF THE ABOVE</p> <p>IV. THE BENEFICIAL OWNER FOR THE PURPOSE OF (III) ABOVE WILL BE AS UNDER:</p> <p>1. IN CASE OF A COMPANY OR LIMITED LIABILITY PARTNERSHIP, THE BENEFICIAL OWNER IS THE NATURAL PERSON (S) WHO, WHETHER ACTING ALONE OR TOGETHER, OR THROUGH ONE OR MORE JURIDICAL PERSON, HAS A CONTROLLING OWNERSHIP INTEREST OR WHO EXERCISES CONTROL THROUGH OTHER MEANS.</p> <p style="text-align: center;">EXPLANATION –</p> <p>a. "CONTROLLING OWNERSHIP INTEREST" MEANS OWNERSHIP OF OR ENTITLEMENT TO MORE THAN TWENTY-FIVE PER CENT. OF SHARES OR CAPITAL OR PROFITS OF THE COMPANY</p> <p>b. "CONTROL" SHALL INCLUDE THE RIGHT TO APPOINT MAJORITY OF THE DIRECTORS OR TO CONTROL THE MANAGEMENT OR POLICY DECISIONS INCLUDING BY VIRTUE OF THEIR SHAREHOLDING OR MANAGEMENT RIGHTS OR SHAREHOLDER'S AGREEMENTS OF VOTING AGREEMENTS;</p> <p>2. IN CASE OF A PARTNERSHIP FIRM, THE BENEFICIAL OWNER IS THE NATURAL PERSON (S) WHO, WHETHER ACTING ALONE OR TOGETHER, OR THROUGH ONE OR MORE JURIDICAL OF CAPITAL OR PROFITS OF THE PARTNERSHIP;</p> <p>3. IN CASE OF AN UNINCORPORATED ASSOCIATION OR BODY OF INDIVIDUALS, THE BENEFICIAL OWNER IS THE NATURAL PERSON (S), WHO, WHETHER ACTING ALONE OR TOGETHER, OR THROUGH ONE OR MORE JURIDICAL PERSON, HAS OWNERSHIP OF OR ENTITLEMENT TO MORE THAN FIFTEEN PERCENT OF THE PROPERTY OF CAPITAL OF PROFITS OF SUCH ASSOCIATION OR BODY OF INDIVIDUALS;</p> <p>4. WHERE NO NATURAL PERSON IS IDENTIFIED UNDER (1) OR (2) OR (3) ABOVE, THE BENEFICIAL OWNER IS THE RELEVANT NATURAL PERSON WHO HOLDS THE POSITION OF SENIOR MANAGING OFFICIAL;</p> <p>5. IN CASE OF TRUST, THE IDENTIFICATION OF BENEFICIAL OWNER (S) SHALL INCLUDE IDENTIFICATION OF THE AUTHOR OF THE TRUST, THE TRUSTEE, THE BENEFICIARIES WITH FIFTEEN PERCENT OR MORE INTEREST IN THE TRUST AND ANY OTHER NATURAL PERSON EXERCISING ULTIMATE EFFECTIVE CONTROL OVER THE TRUST THROUGH A CHAIN OF CONTROL OR OWNERSHIP.</p> <p>V. AN AGENT IS A PERSON EMPLOYED TO DO ANY ACT FOR ANOTHER, OR TO REPRESENT ANOTHER IN DEALINGS WITH THIRD PERSON.</p> <p><b>CERTIFICATE:</b> IN ORDER TO AVAIL THE BENEFITS, VENDORS TO SUBMIT (ALONG WITH OFFER) THE SELF-CERTIFICATION THAT THE ITEM OFFERED MEETS THE CONTENT REQUIREMENT FOR CLASS-I/ CLASS-II LOCAL SUPPLIER AS THE CASE MAY BE, INDICATING THE PERCENTAGE OF LOCAL CONTENT. AND SHALL GIVE DETAILS OF LOCATION AT WHICH THE LOCAL VALUE ADDITION IS MADE (refer attached Make in India (Model Certificate no I)).</p>	
53	<p><b>FORCE MAJEURE :</b> NOTWITHSTANDING ANYTHING CONTAINED IN THE CONTRACT, NEITHER THE VENDOR NOR THE BHEL SHALL BE HELD RESPONSIBLE FOR TOTAL OR PARTIAL NON-EXECUTION OF ANY OF THE CONTRACTUAL OBLIGATIONS, SHOULD THE OBLIGATION BECOME UNREASONABLY ONEROUS OR IMPOSSIBLE DUE TO OCCURRENCE OF A 'FORCE MAJEURE' WHICH DIRECTLY AFFECTS THE OBLIGATIONS TO BE PERFORMED BY THE BHEL OR THE VENDOR ; SUCH EVENTS INCLUDE WAR, MILITARY OPERATIONS OF ANY NATURE, BLOCKAGES, REVOLUTIONS, INSURRECTIONS, RIOTS, CIVIL COMMOTIONS, INSURGENCY, SABOTAGE, ACTS OF PUBLIC ENEMY, FIRES, EXPLOSION, EPIDEMICS, QUARANTINE RESTRICTIONS, FLOODS, EARTHQUAKE, OR ACTS OF GOD, RESTRICTIONS BY GOVT. AUTHORITIES; OVER WHICH THE VENDOR OR THE BHEL HAS NO CONTROL. THE PARTY CLAIMING TO BE AFFECTED BY FORCE MAJEURE SHALL NOTIFY THE OTHER PARTY IN WRITING WITHOUT DELAY, WITHIN TWO WEEKS ON THE INTERVENTION AND ON THE CESSATION OF SUCH CIRCUMSTANCE. EXTENSION OF TIME SOUGHT BY THE VENDOR ALONG WITH SUPPORTING EVIDENCE AND SO GRANTED BY THE BHEL FOR THE SUPPLY/ WORK AFFECTED, IF ANY, SHALL NOT BE CONSTRUED AS WAIVER IN RESPECT OF REMAINING DELIVERIES. RESCHEDULING OF DELIVERIES ON ACCOUNT OF FORCE MAJEURE CONDITIONS, IF SO AGREED BY THE BHEL, WILL NOT ENTAIL THE VENDOR TO CLAIM ANY INCREASE IN THE PRICE ON WHATSOEVER ACCOUNT. NOTWITHSTANDING ABOVE PROVISIONS, BHEL SHALL RESERVE THE RIGHT TO CANCEL THE ORDER/ CONTRACT, WHOLLY OR PARTLY, IN ORDER TO MEET THE OVERALL PROJECT SCHEDULE AND MAKE ALTERNATIVE ARRANGEMENTS. IF DEEMED NECESSARY, BHEL MAY TAKEOVER PARTLY PROCESSED MATERIAL AT A MUTUALLY AGREED PRICE.</p>	
54	<p><b>FRAUD PREVENTION POLICY :</b> THE BIDDER ALONG WITH ITS ASSOCIATE/ COLLABORATORS/ SUB-CONTRACTORS/ SUB-VENDORS/ CONSULTANTS/ SERVICE PROVIDERS SHALL STRICTLY ADHERE TO BHEL FRAUD PREVENTION POLICY DISPLAYED ON BHEL WEBSITE WWW.BHEL.COM AND SHALL IMMEDIATELY BRING TO THE NOTICE OF BHEL MANAGEMENT ABOUT ANY FRAUD OR SUSPECTED FRAUD AS SOON AS IT COMES TO THEIR NOTICE.</p>	
55	<p><b>SHORT SHIPMENTS/ WARRANTY/GUARANTEE REPLACEMENTS:</b> IN CASE OF ANY SHORT SHIPMENT DURING INITIAL SUPPLY WHICH IS SUBSEQUENTLY DISPATCHED BY THE VENDOR OR ANY GUARANTEE / WARRANTY REPLACEMENTS SHALL BE DISPATCHED ON " "FOR-BHEL STORES/DESIGNATED DESTINATION" BASIS FOR INDIGENOUS ITEMS. TAXES, IF ANY PAID BY INDIGENOUS VENDOR FOR GUARANTEE /WARRANTEE REPLACEMENT, REPAIR ACTIVITY EXCLUDING SHORT SUPPLY SHALL BE TO VENDOR'S ACCOUNT ONLY. THE VENDOR HAS TO RAISE A CREDIT NOTE FOR SHORT SUPPLIED QUANTITY AS PER GST PROVISIONS.</p>	
56	<p><b>E WAY BILL:</b> THE SUPPLIER HAS TO ARRANGE FOR E WAY BILL AS APPLICABLE FOR ANY MOVEMENT OF GOODS ALONG WITH OTHER PRESCRIBED DOCUMENTS AS PER GST LAW. THE SUPPLIER HAS ALSO TO COMPLY WITH ANY AMENDMENT AS PRESCRIBED FROM TIME TO TIME UNDER E WAY BILL RULE. ANY FINANCIAL IMPLICATION ARISES ON BHEL DUE TO NONCOMPLIANCE OF E WAY BILL RULE WILL BE PASSED ON TO THE SUPPLIER.</p>	
57	<p><b>PRICING TERMS:</b> PRICES ONCE QUOTED SHALL REMAIN FIRM WITHIN THE VALIDITY OR ANY EXTENSION THEREOF FOR PLACEMENT OF ORDER, TILL COMPLETE EXECUTION OF THE ORDER, WITHOUT ANY ESCALATION/INCREASE FOR ANY REASON, WHATSOEVER, UNLESS SPECIFICALLY PROVIDED FOR IN THE ENQUIRY &amp; PO. IN CASE OF FOREIGN VENDORS, THE QUOTED PRICE SHALL BE TAKEN AS INCLUSIVE OF THIRD PARTY INSPECTION AND TESTING CHARGES AS CALLED FOR IN THE NIT.</p>	
58	<p>THE VENDOR SHOULD PROVIDE BILLS &amp; OTHER DOCUMENTS COMPLETE IN ALL RESPECT AS PER PURCHASE ORDER ALONGWITH DESPATCH OF MATERIALS. FURTHER, BHEL SHALL SEEK CLARIFICATION(S) (IF ANY) RELATED TO PAYMENT DOCUMENTS IN ONE GO. THE VENDOR SHOULD PROVIDE ALL SUCH CLARIFICATION(S) IMMEDIATELY.ANY DELAY IN PROCESSING OF PAYMENT, DUE TO NON RECEIPT OF CLARIFICATION(S) SOUGHT BY BHEL, SHALL BE</p>	



# Bharat Heavy Electricals Limited

## Heavy Equipment Repair Plant (HERP)

Tarna, Shivpur, Varanasi - 221003

	ATTRIBUTABLE COMPLETELY TO VENDOR.	
59	THE STARTUPS AS DEFINED IN THE GAZETTE OF INDIA NOTIFICATION NO.: G.S.R. 127 (E) DATED 19/02/2019 WILL BE EXEMPTED FROM FULFILLING THE CRITERIA, IF MENTIONED, IN THE PQR (PRE-QUALIFYING REQUIREMENT) REGARDING PRIOR TURNOVER AND PRIOR EXPERIENCE. HOWEVER, THERE MAY BE CIRCUMSTANCES (LIKE PROCUREMENTS OF ITEMS RELATED TO PUBLIC SAFETY, HEALTH, CRITICAL SECURITY OPERATIONS AND EQUIPMENTS ETC.) WHERE BHEL MAY PREFER THE VENDORS TO HAVE PRIOR EXPERIENCE RATHER THAN GIVING ORDER TO NEW ENTITIES. FOR SUCH PROCUREMENTS, BHEL MAY NOT RELAX THE CRITERIA OF PRIOR EXPERIENCE/TURNOVER FOR THE STARTUPS.	
60	THE VENDOR SHALL ENSURE THAT THEIR BANK DETAILS ARE UPDATED WITH US FOR TIMELY PAYMENT THROUGH EFT (ELECTRONICS FUND TRANSFER).	
61	THE BIDDER DECLARES THAT THEY WILL NOT ENTER INTO ANY ILLEGAL OR UNDISCLOSED AGREEMENT OR UNDERSTANDING, WHETHER FORMAL OR INFORMAL WITH OTHER BIDDER (S). THIS APPLIES IN PARTICULAR TO PRICES, SPECIFICATIONS, CERTIFICATIONS, SUBSIDIARY CONTRACTS, SUBMISSION OR NON- SUBMISSION OF BIDS OR ANY OTHER ACTIONS TO RESTRICT COMPETITIVENES OR TO INTRODUCE CARTELIZATION IN THE BIDDING PROCESS. IN CASE, THE BIDDER IS FOUND HAVING INDULGED IN ABOVE ACTIVITIES, SUITABLE ACTION SHALL BE TAKEN BY BHEL AS PER EXTANT POLICIES / GUIDELINES.	
62	THE BIDDER SHALL REGISTER THEMSELVES ON GEM PORTAL AND SHALL QUOTE THEIR GEM SELLER ID IN THEIR OFFER. GEM SELLER ID IS MANDATORY FOR PLACEMENT OF PURCHASE ORDER EXCEPT IN CASES WHERE FREE ISSUE MATERIAL IS TO BE ISSUED BY BHEL .	
63	<ol style="list-style-type: none"><li>1. THE TECHNICAL BID OF ONLY THOSE BIDDERS SHALL BE PROCESSED WHO MEET THE PREQUALIFYING REQUIREMENT AS PER ANNEXURE-B.</li><li>2. DELIVERY, INSTALLATION &amp; COMMISSIONING PERIOD, WARRANTY: AS PER CLAUSE 16 OF ANNEXURE-A HOWEVER EARLY DELIVERY CLAUSE IS ACCEPTABLE.</li><li>3. MATERIAL TO BE SUPPLIED AT BHEL STORES.</li><li>4. JOB PROVE OUT REQUIREMENT : REFER CLAUSE 6 OF ANNEXURE-A</li><li>5. CIVIL WORK FOR FOUNDATION SHALL BE IN SCOPE OF BHEL. VENDOR SHOULD SUBMIT DETAILS AS PER CLAUSE 8 of ANNEXURE-A.</li><li>6. THIRD PARTY INSPECTION- NOT APPLICABLE</li><li>7. PRE DISPATCH INSPECTION:-AS PER CLASUE 7 OF THE ANNEXURE-A.</li><li>8. BY SUBMITTING THEIR QUOTATION AGAINST THIS BID IT IS DEEMED THAT VENDORS AGREE TO EACH AND EVERY TERMS &amp; CONDITIONS MENTIONED IN THE BID.</li><li>9. "THE OFFERS OF THE BIDDERS WHO ARE ON THE BANNED LIST AND ALSO THE OFFER OF THE BIDDERS, WHO ENGAGE THE SERVICES OF THE BANNED FIRMS, SHALL BE REJECTED. THE LIST OF BANNED FIRMS IS AVAILABLE ON BHEL WEB SITE <a href="http://www.bhel.com">www.bhel.com</a>".</li><li>10. MSEs &amp; Central/State PSE SHALL BE EXEMPTED FROM PAYMENT OF EARNEST MONEY COST AT THE TIME OF TENDER DEPOSIT. HOWEVER, THERE IS NO EXEMPTION OF SECURITY DEPOSIT SUBMISSION. NO BENEFITS SHALL BE APPLICABLE FOR THAT PARTICULAR ENQUIRY IF THE REQUIRED DOCUMENTS ARE NOT SUBMITTED BEFORE PRICE BID OPENING.</li><li>11. P.B.G. TERMS: THE VENDOR IS REQUIRED TO SUBMIT A PERFORMANCE BANK GUARANTEE ON THE PRESCRIBED BHEL FORMAT FROM ANY OF THE CONSORTIUM BANKS OF BHEL EQUAL TO THE VALUE OF 03% OF THE TOTAL ORDER VALUE VALID FOR 60 DAYS BEYOND THE AGREED WARRANTY / GUARANTEE PERIOD. THE PBG CONFIRMATION CHARGES IS TO BE BORNE BY VENDOR.</li></ol>	

**NOTE:**

1. FOR FOREIGN SUPPLIERS: **CLAUSE NO. 13, 19, 41, 42, 43, 50, 59 & 62** ARE NOT APPLICABLE FOR 'FOREIGN SUPPLIERS'. IT IS APPLICABLE FOR ONLY INDIAN SUPPLIERS.
2. PLEASE FILL IN THIS FORMAT AND SEND COMPULSORILY ALONG WITH QUOTATION WITH VENDOR'S SEAL, SIGNATURE AND DATE.

**SIGNATURE ALONG WITH SEAL AND DATE:**



**Bharat Heavy Electricals Limited**  
**Heavy Equipment Repair Plant (HERP)**

Tarna, Shivpur, Varanasi - 221003

**Annexure-VII**

**DETAILS OF COMPOSITION OF PART-I (TECHNO-COMMERCIAL BID), PART-II (PRICE BID) & PART-III (Supplier REGISTRATION FORM)**

**PART-I (TECHNO-COMMERCIAL BID) shall comprise of following documents:**

1. Documents in line to PQR.
2. Filled, signed and stamped copy of the tender documents.

**PART –II (Price Bid):**

- A. Price bid with prices to be submitted as part-II of the tender.
- B. Prices should remain firm till the execution of the order.

**Part-III - Vendor Registration Form (SRF):**

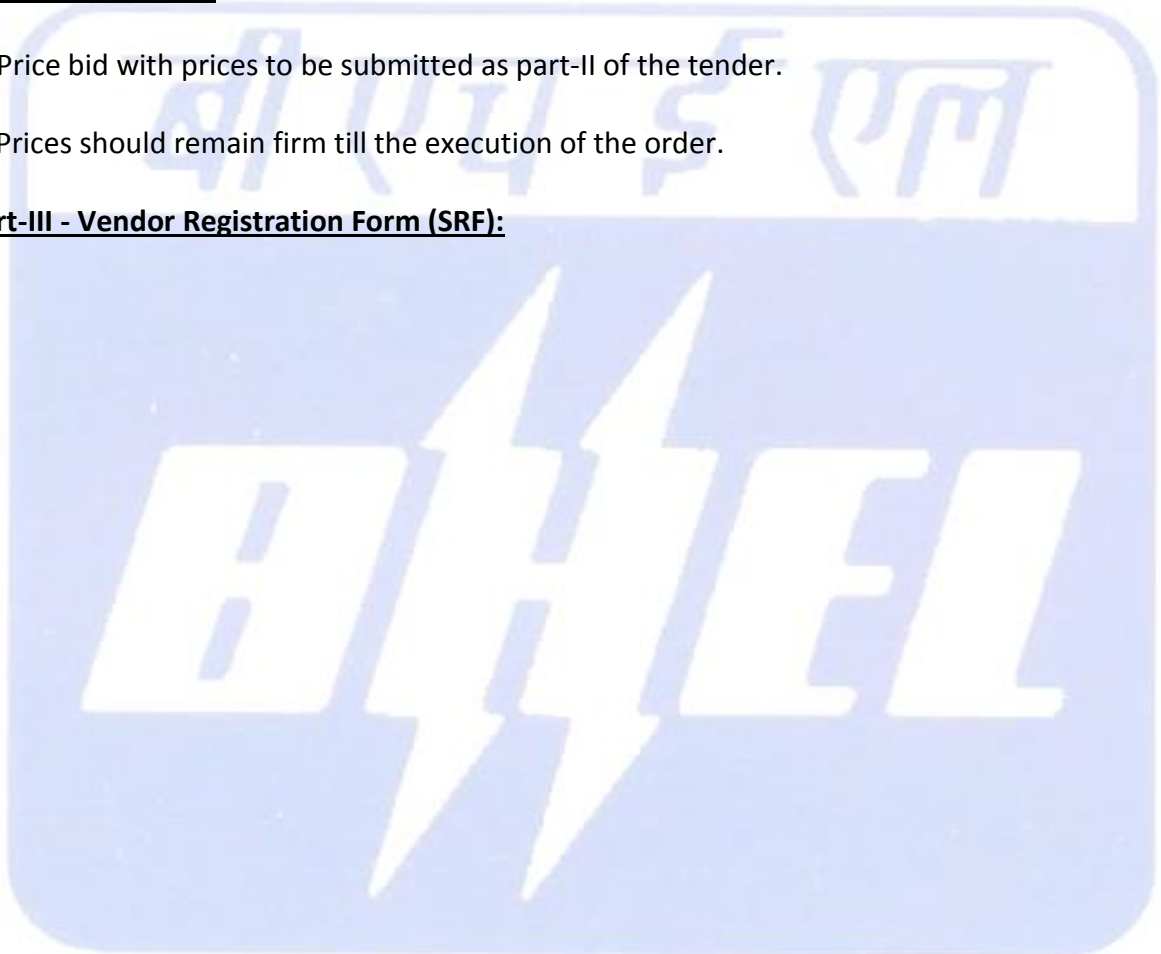





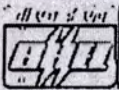
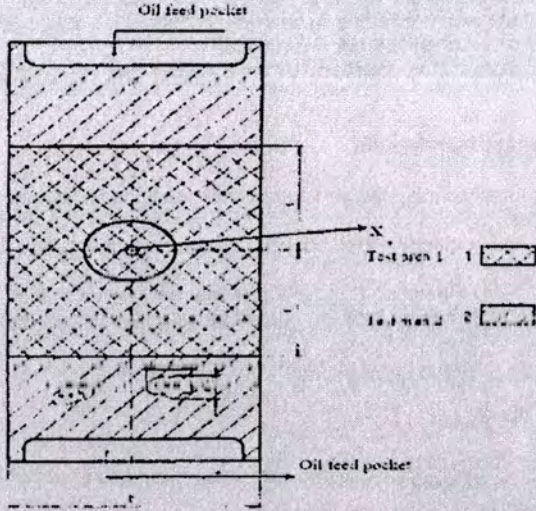

<p>पंजीकृत संख्या INVENTORY NO <b>P-3041</b></p>	<p>REV. NO. <b>02</b></p>	<p>संस्थान मानक (हीप - हरिद्वार) <b>PLANT STANDARD (HEEP - HARDWAR)</b></p>	<p>HW 0850195 पृष्ठ का Page 7 of 11</p>
<p>संशोधन संख्या RESEARCH NO</p>	<p><b>6.3 Execution of Test</b></p> <p>The ultrasonic testing is done on the bearing metal in the test area with an overlap of about 20% of successive scanning tracks to ensure 100% coverage of the babbited surface. In the transitional area between groove and land as well as at oil ducts, the test may not be possible because of attendant pulse distortion. Recordable indications are demarcated on a square frame and subsequently plotted in the test report.</p>		
<p>कॉपीराइट और कॉन्फिडेंटियल COPYRIGHT AND CONFIDENTIAL Manufacture and distribution of this document is the property of Bharat Heavy Electrical Limited. It must not be used, stored, or distributed, in whole or in part, without the consent of the company.</p>	<p><b>6.4 Assessment of Test Results</b></p> <p>a) For plain thrust bearings, the sum total of the non bong areas must be less than 2% of the total surface. b) The acceptance criteria differ between bearing types and also between top &amp; bottom halves. Two stage, plain sleeve and modified cylindrical bearings shall be assessed as per annexure I. Three/four stage bearings are to be assessed as per Annexure -II c) Acceptance criteria for sealing ring shall be as per annexure -III.</p> <p><b>6.5 Documentation</b></p> <p>The results of dye penetrant test and Ultrasonic Test shall be prepared on the formats QC-76 &amp; QC-119 respectively.</p> <p>If recordable indications are found in UT or unacceptable indications are found in DPT, the exact position &amp; extent of the indications must be recorded in the report using a proper dimensioned sketch.</p> <p>In case permissible indications are exceeded Metallurgy &amp; the concerned engineering department is to be consulted who shall decide possibility of using the component.</p>		
<p>स्वतंत्रतापूर्वक एवं गोपनीय स्वतंत्रतापूर्वक एवं गोपनीय This document is the property of Bharat Heavy Electrical Limited. It must not be used, stored, or distributed, in whole or in part, without the consent of the company.</p>	<p><b>7. Cross Referred Standards</b></p> <p>1) AA0850131                      2) AA0850159</p>		
<p>पंजीकृत तिथि DATE <b>11/4/10/08</b></p>			
<p>पंजीकृत संख्या INVENTORY NO <b>P-3041</b></p>	<p>REV. NO. <b>02</b></p>	<p>काम करने वाला WORKED BY <b>Kamal Sehgal</b></p>	<p>श्रीमान Sh Kamal Sehgal</p> <p>चेक करने वाला CHECKED BY <b>Vivek Mittal</b>    <b>DGM</b>    <b>MPL</b></p>

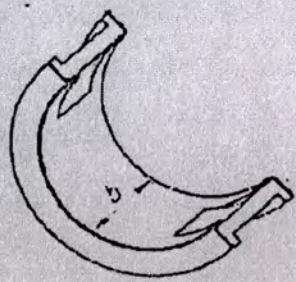
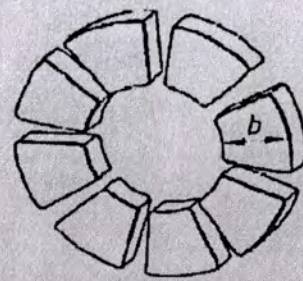
संस्था का लोगो 	<b>संस्थान मानक (डीप - हार्डवेयर)</b> <b>PLANT STANDARD (DEEP HARDWARE)</b>	<b>HW 0850195</b> पृष्ठ का <b>Page 8 of 11</b>								
SUPERSEDES INVENTORY NO.	<b>Annexure-I</b>									
प्रमाणित करने वाला APPROVED BY	<b>Two Stage Plain Sleeve &amp; Modified Cylindrical Bearings</b> <b>(Fig.8)</b>									
कॉपीराइट और कॉन्फिडेंशियल COPYRIGHT AND CONFIDENTIAL										
स्वामित्वकारी एवं गोपनीय PROPRIETARY AND CONFIDENTIAL	<b>Fig.8</b>									
प्रमाणित करने की तिथि DATE	<b>b = Bearing width (mm)</b> <b>c = Width of area with non bonding in test area 2(mm)</b> <b>e = Length of area with non bonding in test area 2(mm)</b> <b>D = Bearing diameter (mm)</b>									
प्रमाणित करने की तिथि DATE	$L = \frac{D \times \pi \times \alpha}{360^\circ} \text{ (mm)}$									
प्रमाणित करने की तिथि DATE	For 2 stage and plain sleeve ( $\alpha=45^\circ$ ) apply $L = 0,393 \times D \text{ (mm)}$									
प्रमाणित करने की तिथि DATE	For modified cylindrical bearing ( $\alpha = 30^\circ$ ) apply $L = 0,262 \times D \text{ (mm)}$									
INVENTORY NO. <b>P-3041</b>	REV. NO. <b>02</b>	<table border="1" style="width:100%; border-collapse: collapse;"> <tr> <td style="width:20%;">निर्माण-कर्ता WORKED BY</td> <td style="width:20%;">Sh Kamal Sehgal <i>Kamal Sehgal</i></td> <td style="width:20%;"></td> <td style="width:20%;"></td> </tr> <tr> <td>जांचकर्ता CHECKED BY</td> <td>Sh Vivek Mittal <i>Vivek Mittal</i></td> <td>DGM</td> <td>MPL</td> </tr> </table>	निर्माण-कर्ता WORKED BY	Sh Kamal Sehgal <i>Kamal Sehgal</i>			जांचकर्ता CHECKED BY	Sh Vivek Mittal <i>Vivek Mittal</i>	DGM	MPL
निर्माण-कर्ता WORKED BY	Sh Kamal Sehgal <i>Kamal Sehgal</i>									
जांचकर्ता CHECKED BY	Sh Vivek Mittal <i>Vivek Mittal</i>	DGM	MPL							

ड्राफ्टिंग कोड INVENTORY NO <b>P-3041</b>	संस्था मानक <b>PLANT STANDARD</b>	(सीप - इरिद्वार) (HEEP - HARDWAR)	IIW 0850195 पृष्ठ का Page 9 of 11
ड्राफ्टिंग कोड INVENTORY NO <b>P-3041</b>	<p><b>X= 100% no bond allowed on the Al-Bronze washer (shown as X in the above sketch)</b></p> <p>The <b>TEST ZONE 1</b> is defined as the crosshatched area in the above figure for the bottom half. In this region non-bonding is not acceptable.</p> <p>The <b>TEST ZONE 2</b> covers entire top half and the single hatched areas of the bottom half. Each indication area has to be assessed individually in view of the percentage of the defect area and of edge zone and/or edge lengths.</p> <p>In this zone:</p> <ul style="list-style-type: none"> <li>- The total area with non bonding must not exceed 5% of each individual test range.</li> <li>- Individual non bond areas of size upto <math>A=4 \times b</math> are permissible, provided two isolated non bond areas are separated by at least 10mm from each other, otherwise they are to be treated as a single defect.</li> <li>- The width/length ratio of the non bonding area confirms to <math>e/c \geq \frac{1}{4}</math> where e &amp; c are explained in the sketch above.</li> <li>- At edge zone, max 4 % defect length related to the single edge length but not exceeding 20 mm is permissible.</li> </ul> <p><b>Note:</b></p> <ul style="list-style-type: none"> <li>- The edge zone is the visible transition from the backing to the backing material</li> <li>- In case of journal bearing, the edge length is the edge zone of the joint face (b in fig 9)</li> <li>- In case of thrust bearing, the edge length is the edge zone of plane face (b in Fig 10)</li> </ul>		
COPYRIGHT AND CONFIDENTIAL This information is the property of the organization and is to be kept confidential. It is not to be disclosed to any other person without the prior written permission of the organization.	 <p style="text-align: center;">Fig 9</p>  <p style="text-align: center;">Fig.10</p>		
स्वतंत्रता दिवस 15 अगस्त 2022	ड्राफ्टिंग कोड INVENTORY NO <b>P-3041</b>		
ड्राफ्टिंग कोड INVENTORY NO <b>P-3041</b>	ड्राफ्टिंग कोड INVENTORY NO <b>P-3041</b>	ड्राफ्टिंग कोड INVENTORY NO <b>P-3041</b>	ड्राफ्टिंग कोड INVENTORY NO <b>P-3041</b>
ड्राफ्टिंग कोड INVENTORY NO <b>P-3041</b>	ड्राफ्टिंग कोड INVENTORY NO <b>P-3041</b>	ड्राफ्टिंग कोड INVENTORY NO <b>P-3041</b>	ड्राफ्टिंग कोड INVENTORY NO <b>P-3041</b>
ड्राफ्टिंग कोड INVENTORY NO <b>P-3041</b>	ड्राफ्टिंग कोड INVENTORY NO <b>P-3041</b>	ड्राफ्टिंग कोड INVENTORY NO <b>P-3041</b>	ड्राफ्टिंग कोड INVENTORY NO <b>P-3041</b>
ड्राफ्टिंग कोड INVENTORY NO <b>P-3041</b>	ड्राफ्टिंग कोड INVENTORY NO <b>P-3041</b>	ड्राफ्टिंग कोड INVENTORY NO <b>P-3041</b>	ड्राफ्टिंग कोड INVENTORY NO <b>P-3041</b>
ड्राफ्टिंग कोड INVENTORY NO <b>P-3041</b>	ड्राफ्टिंग कोड INVENTORY NO <b>P-3041</b>	ड्राफ्टिंग कोड INVENTORY NO <b>P-3041</b>	ड्राफ्टिंग कोड INVENTORY NO <b>P-3041</b>
ड्राफ्टिंग कोड INVENTORY NO <b>P-3041</b>	ड्राफ्टिंग कोड INVENTORY NO <b>P-3041</b>	ड्राफ्टिंग कोड INVENTORY NO <b>P-3041</b>	ड्राफ्टिंग कोड INVENTORY NO <b>P-3041</b>

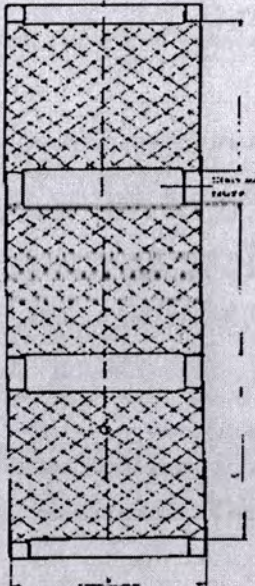
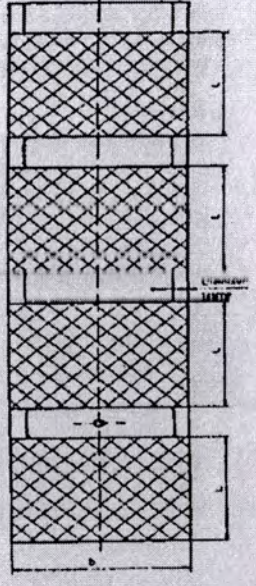
संस्था संस्था का नाम संस्था का पता		<b>संस्थान मानक (सीप - हार्डवेयर)</b> <b>PLANT STANDARD (HEEP - HARDWARE)</b>	<b>HW 0850195</b> पृष्ठ का Page 10 of 11								
संस्था का नाम संस्था का पता	<b>Annexure-II</b> <b>Three &amp; Four Stage Bearings</b> In these bearings the tooth area shall consist of cross hatched areas as shown below. Non bond areas are not allowed in these bearings.										
<b>COPYRIGHT AND CONFIDENTIAL</b> The information contained in this document is the property of HEEP (Heavy Electrical Engineering & Manufacturing Corporation) and shall not be used, disclosed or reproduced in any form without the written consent of the company.	<div style="display: flex; justify-content: space-around;"> <div style="text-align: center;">  <p>3 stage bearing</p> <math display="block">L = \frac{D \times \pi \times 100^\circ}{360^\circ} \text{ (mm)}</math> <p>Fig. 11</p> </div> <div style="text-align: center;">  <p>4 stage bearing</p> <math display="block">L = \frac{D \times \pi \times 70^\circ}{360^\circ} \text{ (mm)}</math> <p>Fig. 12</p> </div> </div>										
संस्था का नाम संस्था का पता	3 stage bearing $L = \frac{D \times \pi \times 100^\circ}{360^\circ} \text{ (mm)}$ Fig. 11										
संस्था का नाम संस्था का पता	4 stage bearing $L = \frac{D \times \pi \times 70^\circ}{360^\circ} \text{ (mm)}$ Fig. 12										
संस्था का नाम संस्था का पता	REV. NO. 02		<table border="1" style="width: 100%; border-collapse: collapse;"> <tr> <td style="width: 20%;">निर्माता WORKED BY</td> <td style="width: 30%;">Sh Kamal Sehgal <i>Kamal Sehgal</i></td> <td style="width: 20%;"></td> <td style="width: 30%;"></td> </tr> <tr> <td>जांचकर्ता CHECKED BY</td> <td>Sh Vivek Mittal <i>Vivek Mittal</i></td> <td><i>Dim</i></td> <td><i>mpl</i></td> </tr> </table>	निर्माता WORKED BY	Sh Kamal Sehgal <i>Kamal Sehgal</i>			जांचकर्ता CHECKED BY	Sh Vivek Mittal <i>Vivek Mittal</i>	<i>Dim</i>	<i>mpl</i>
निर्माता WORKED BY	Sh Kamal Sehgal <i>Kamal Sehgal</i>										
जांचकर्ता CHECKED BY	Sh Vivek Mittal <i>Vivek Mittal</i>	<i>Dim</i>	<i>mpl</i>								

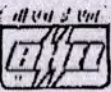
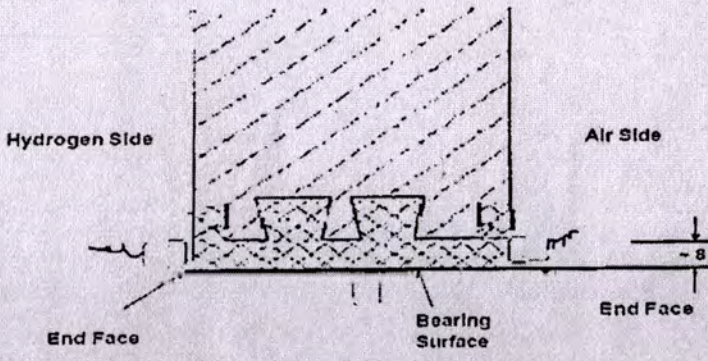
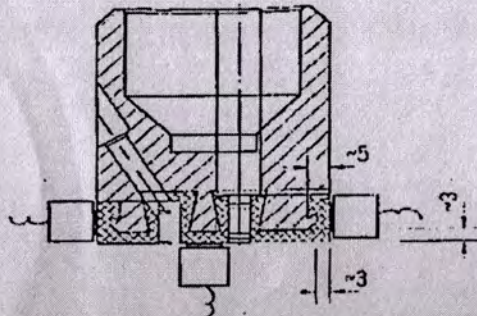
Date of entry 20/05/1987		<b>संस्थान मानक (डीप - हरिद्वार)</b> <b>PLANT STANDARD (DEEP - HARDWAR)</b>	<b>HW 0850195</b> पृष्ठ का Page 11 of 11
Date of issue 20/05/1987	<b>Annexure-III</b> <b>Sealing Rings</b> The ultrasonic testing shall be done on end faces and bearing surfaces as shown in figure 13 and 14		
Copyright and Confidential This document is the property of the organization. It should not be used for any other purpose without the permission of the organization.			
स्वीकृतिकार एवं गोपनीय For purpose of inspection and maintenance of equipment, this document is to be used only for the purpose of the equipment.			
Date of issue 20/05/1987	<b>Fig. 13. Ultrasonic testing after rough machining.</b> <b>Fig. 14. Ultrasonic testing after final machining.</b>		
<b>Acceptance norms for sealing rings</b> A maximum of 4 recordable indications, with a total recording length of 50 mm on each end face and bearing surface. Maximum allowable length of individual indication is 15 mm. The distance to adjacent indications shall be at least twice the defect length of the larger indication. Otherwise, the indication free space between the indications must be added to total indication length, in addition to the individual indication length.			
Inventory No <b>P-3043</b>	REV. NO. 02	Prepared by Sh Kamal Sehgal	WORKED BY <i>Kamal Sehgal</i>
Date of issue <b>20/05/1987</b>		Checked by Sh. Vivek Mittal	CHECKED BY <i>Vivek Mittal Dharm msl</i>

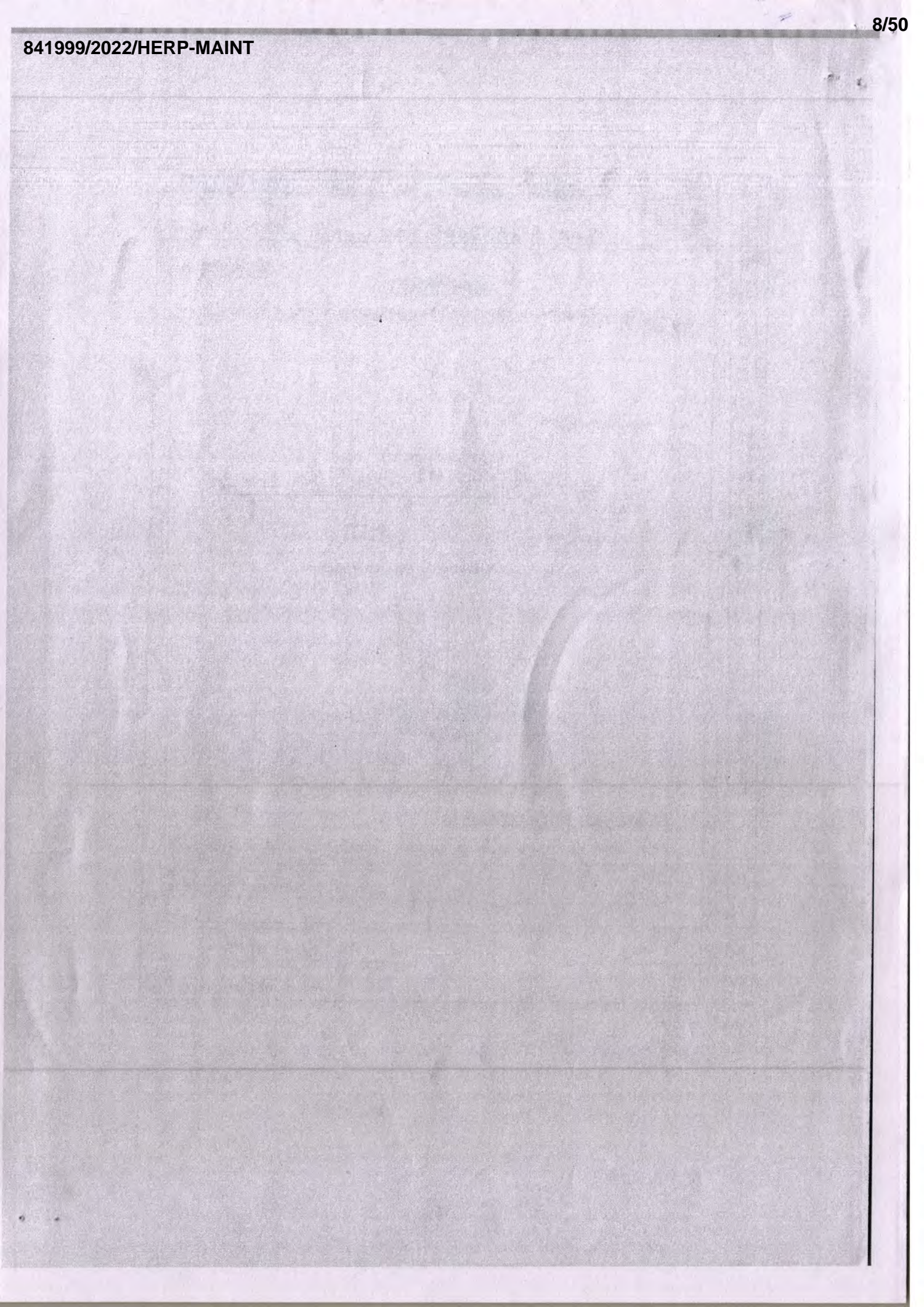

दिनांक एवं हस्ताक्षर SIGN & DATE		संस्थान क्रय विनिर्देश (हीप - हरिद्वार)	HW12897		
			पृष्ठ	का	
		PLANT PURCHASE SPECIFICATION (HEEP - HARDWAR)	Page	1	of 3

**Special Tin Based Antifriction Bearing Alloy**

1/3

- General:**  
This specification governs the requirements of tin based antifriction bearing alloy.
- Application:**  
For Babbitt lining of journal and thrust bearings on cast iron and cast/forged steel bearings shells.
- Condition of Delivery:** As cast ingots.
- Dimension & Tolerances:**  
Weight of each ingot shall not be more than 3kg.
- Freedom from Defects:**  
The ingots shall be homogeneous and free from non-metallic inclusions and shall have smooth appearance.
- Manufacture:**  
The babbitt alloy shall be manufactured from virgin metals only. Return scrap shall not be used. The manufacturer shall take all precautions to ensure proper mixing of the alloying elements and the melt homogeneous.

**7. Chemical Composition (weight %):**  
The chemical composition of the Babbitt when analysed in accordance with IS:1409 (methods of chemical analysis of antifriction bearing alloy) or by any other conventional / instrumental method shall be as follows:

Sn	Cd	Cu	Sb	Ni	As	Pb	Fe	Zn	Al
80.0 - 81.9	1.0 - 1.4	5.0 - 5.5	11.0 - 13.0	0.20 - 0.50	0.30 - 0.70	< 0.06	≤ 0.01	≤ 0.02	≤ 0.02

Alternatively, Babbitt as per below mentioned chemistry is also acceptable.

Sn	Sb	Cu	Ag	Cd	Ni	Bi	As	Pb	Fe	Zn	Al
Rest	11.0 - 13.0	5.5 - 6.5	0.05 - 0.15	< 0.03	< 0.06	< 0.06	< 0.06	< 0.06	< 0.03	0.5 - 0.7	< 0.01

TSX	R. VARMA		नाम	दिनांक एवं हस्ताक्षर
QAX	SUGANDH AGARWAL		NAME	SIGNATURE & DATE
IPSC	VK Chauhan		निर्माणाकर्ता WORKED BY	Ashish Ranjan
STE	D K RAY		जांचकर्ता CHECKED BY	T S Gopalkrishnan
AGREED DEPTT	नाम	दिनांक एवं हस्ताक्षर	पर्यवेक्षणकर्ता SUPERVISED BY	J.P.Meena
स्वीकृति : संस्थान मानक समिति APPROVED : PLANT STANDARDS COMMITTEE			Gp.No. 2.65	
Rev. No. 05			निर्माणाकर्ता PREPARED : MTF	जारी : मानक विभाग ISSUED : STANDARDS DIVISION
Dt. 07.09.2012				दिनांक : DATE : 19.08.88

COPYRIGHT AND CONFIDENTIAL  
The information on this document is the property of Bharat Heavy Electricals Limited. It must not be used directly or indirectly in any way detrimental to the interests of the company.

स्वत्वाधिकार एवं गोपनीय  
इस दस्तावेज में दी गई सूचना भारत हीवी इलेक्ट्रिकल्स की संपत्ति है। इसका प्रयोग एवं आशयपूर्ण रूप से किसी भी तरह प्रयोग, जो कि कंपनी को हित में मानिकारक हो या किसी अन्य

हस्ताक्षर एवं दिनांक  
SIGN & DATE

संयोजी सूची संख्या  
INVENTORY NO.

INVENTORY NO. TLV 9977/02 New 01

P-3061

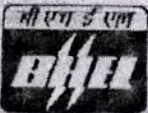
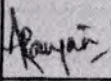
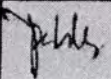
दिनांक एवं प्रमाणांक SIGN & DATE		<b>संस्थान क्रय विनिर्देश (हीप - हरिद्वार)</b>  <b>PLANT PURCHASE SPECIFICATION</b> (HEEP - HARDWAR)	<b>HW12897</b> पृष्ठ का Page 2 of 3			
SUPERSIDES INVENTORY NO	<b>8. Fracture Test:</b> The fracture surfaces of the ingots when broken at notches shall not show segregation, dross, dirt, spots, overheated metal or any other type of non-metallic inclusions and shall show a fine grain structure.					
स्वत्वाधिकार एवं गोपनीय यह प्रस्ताव या ग्राहक द्वारा प्रस्तुत की गई इलेक्ट्रिकल की सामग्री है इलेक्ट्रिकल प्रदाता को इसका उपयोग केवल अपने स्वयं के उपयोग के लिए ही करना चाहिए, जो कि कंपनी के लिए है।	<b>9. Test Samples:</b> <ul style="list-style-type: none"> <li>Chemical analysis shall be reported on each heat basis.</li> <li>Per heat a minimum of two ingots shall be taken for fracture test.</li> </ul> <b>10. Retest:</b> If any of the selected test samples fail to meet the specified requirement, two additional test samples shall be selected for re-testing without any further treatment and both of these samples should pass for acceptance. All tests shall be repeated at BHEL to verify manufacturer's test results.					
दिनांक एवं प्रमाणांक SIGN & DATE	<b>11. Inspection at Supplier Works:</b> BHEL representative shall have all reasonable facilities afforded to him at any time by the supplier to satisfy himself that the material is being furnished in accordance with this specification. Cutting, marking and testing of test samples may be witnessed by BHEL representative/customer's representative at supplier's works.					
दिनांक एवं प्रमाणांक SIGN & DATE	<b>12. Test Certificate:</b> The supplier shall be submit five copies of the test certificate giving the following information's: <ul style="list-style-type: none"> <li>BHEL Order No.</li> <li>Purchase specification No.</li> <li>Supplier's reference and Name</li> <li>Results of chemical analysis</li> <li>Fracture Test Results</li> <li>Heat No.</li> <li>Consignment / identification No.</li> </ul> <b>13.0 Marking:</b> Ingot shall be clearly marked with the Maker's brand either stamped or cast in with following details: <ul style="list-style-type: none"> <li>BHEL order number</li> <li>Purchase specification number</li> <li>Supplier's reference and Name</li> <li>Results of chemical analysis</li> <li>Heat No.</li> <li>Weight</li> <li>Consignment / Identification No.</li> </ul>					
सामग्री सूची संख्या INVENTORY NO Pr-3061	Rev.No.05		निर्माणकर्ता WORKED BY	Ashish Ranjan		28.03.11
			जांचकर्ता CHECKED BY	Gopal Krishnan		28.03.11

दिनांक एवं हस्ताक्षर SIGN & DATE			<b>संस्थान क्रय विनिर्देश (हीप - हार्डवयर)</b>  <b>PLANT PURCHASE SPECIFICATION</b> (HEEP - HARDWAR)	<b>HW12897</b>  पृष्ठ का <b>Page 3 of 3</b>
SEQUENCE NO. INVENTORY NO.		<p><b>14.0 Rejection &amp; Replacement:</b></p> <p>In the event of material proving defective in the course of melting and casting, such material shall stand rejected, not withstanding any previous certification of satisfactory testing inspection. The supplier shall undertake to replace the materials free of charge without any delay and arrange to take back the rejected material as own cost.</p> <p><b>15.0 Cross Referred Standard: IS: 1409</b></p>		
स्वतंत्र अधिकार एवं गोपनीय <small>इस प्रलेख में दी गई जानकारी केवल हीप के अधिकार क्षेत्र में है। इसका प्रयोग अन्य उद्देश्यों के लिए कर्मियों के बिना अनुमति के नहीं किया जा सकता है।</small>				
दिनांक एवं हस्ताक्षर SIGN & DATE				
INVENTORY NO. P-3061	Rev.No.05	निर्माणकर्ता WORKED BY Ashish Ranjan	जांचकर्ता CHECKED BY Gopal Krishnan	28.03.11  28.3.11



ANN-F

SIGN & DATE 	संस्थान मानक (शिव उद्योग) <b>PLANT STANDARD (HEEP - HARDWAR)</b>		<b>HW 0850195</b> पृष्ठ का Page 1 of 11				
	NON DESTRUCTIVE TESTING OF NEWLY MANUFACTURED (KWU DESIGN) BEARING AND THRUST BEARING PADS MADE OF STEEL Based on: PV 0068 Nov, 2002						
SUPERSEDES INVENTORY NO.	List of Contents						
संस्थागत मानक संख्या	Page No.						
COPYRIGHT AND CONFIDENTIAL The information on this document is the property of Bharat Heavy Electricals Limited. It must not be used directly or indirectly in any way detrimental to the interest of the company.	1.	Scope	2				
	2.	Qualification of Testing Personnel	2				
	3.	Extent & Stage of Test	2				
	4.	Surface Condition	2				
	5.	Dye Penetration Testing	3				
	5.1	Test Parameters	3				
	5.2	Assessment of the Results and Acceptance Criteria	3				
	5.2.1	Micro porosity	4				
	6.	Ultrasonic Test	4				
	6.1	Test Equipment and Probes	4				
	6.2	Setting Sensitivity	5				
	6.2.1	Equipment Setting	5				
	6.2.2	Recording Level	5				
	6.3	Execution of Test	7				
6.4	Assessment of Test Results	7					
6.5	Documentation	7					
7.	Cross Referred Standards	7					
		Annexure - I	8				
		Annexure - II	10				
		Annexure - III	11				
स्वत्वाधिकार एवं गोपनीय यह दस्तावेज कंपनी की संपत्ति है। इसमें उल्लेखित जानकारी को बिना अनुमति के किसी भी व्यक्ति को प्रकट नहीं किया जा सकता है।	TSX B. CHOU DHARY 12/10/08	STE D. K. RAY 15/07/08	EME R. C. Sharma 17.7.08	WG-NDT Sh. A. K. Sharma 08.08.08	QAX N. K. Manwani 19.8.08	MTE ASHISH 19.7.08	SUPERVISED BY Sh. S. J. Ghosh 12/10/08
INVENTORY NO. P-3041 2008 03-10-08	संस्थान मानक समिति APPROVED: PLANT STANDARDS COMMITTEE GPM 6.48			PREPARED: MRL ISSUED: STANDARDS DIVISION DATE: 01-04-1988 2008			

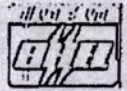
SHEET NO. / PAGE NO. SIGN & DATE		संस्थान मानक (डीप - हार्डवेयर) <b>PLANT STANDARD (HEEP - HARDWAR)</b>	HW 0850195 पृष्ठ का Page 2 of 11			
SPECIFICATION NO. DATE OF ISSUE	<p><b>1. Scope</b></p> <p>This test procedure is applicable for non destructive testing of new or repaired (completely rebabbited) radial sliding bearings, thrust bearing pads and seal rings used in steam turbines and turbo generators</p> <p>This test procedure shall be used for the determination of non-bonding defects</p> <p>a) Between the bearing metal and the base metal and also surface defects in the sliding surface of the bearing.</p> <p>b) Between bearing metal &amp; support and surface defects in contact surface of seal rings.</p> <p>This procedure lays down the procedures for performing dye penetrant testing (DPT) and Ultrasonic Testing (UT) and the acceptance norms.</p>					
COPYRIGHT AND CONFIDENTIAL The information on this document is the property of the organization. It is to be used only for the purpose intended. It is not to be distributed outside the organization.	<p><b>2. Qualification of Testing Personnel</b></p> <p>The testing personnel shall be qualified as per ASNT/ISNT Level -I for dye penetrant testing and Ultrasonic Testing. Final evaluation is to be done by level II personnel.</p> <p><b>3. Extent &amp; Stage of Test</b></p> <p>1.1 After babbiting &amp; rough machining:</p> <p>a) Ultrasonic Testing of the bearing bore in case of bearings</p> <p>b) Ultrasonic Testing of the bearing surface TB pads,</p> <p>c) Ultrasonic Testing of the bearing surface and end faces of seal rings.</p> <p>1.2 After final machining: Dye penetrant testing &amp; ultrasonic testing of the babbitted surface areas shall be done.</p> <p>1.3 After additional final machining: If final machining is completed after delivery (i.e. spare bearing) dye penetrant testing must be repeated.</p>					
सत्यापित एवं गोपनीय This document is the property of the organization. It is to be used only for the purpose intended. It is not to be distributed outside the organization.	<p><b>4. Surface Condition</b></p> <p>The test areas must be free of grease and other contaminants which impair the test. The scanning surface for ultrasonic testing shall not have undulations and tool marks which affect the interpretation of indications.</p> <p>Surface finish <math>R_z \leq 40\mu\text{m}</math> for rough machined bearings and bearing surface of seal rings.          Surface finish <math>R_z \leq 16\mu\text{m}</math> for end faces of seal rings.</p> <p>(For finish machined bearings, the surface finish will be as per drawing).</p>					
REVISED BY DATE	02/11/08					
INVENTORY NO. P-3041	REV. NO. 02		WORKED BY Sh Kamal Sehgal	CHECKED BY Sh Vivek Mittal	DGM	MRL

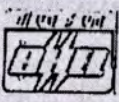
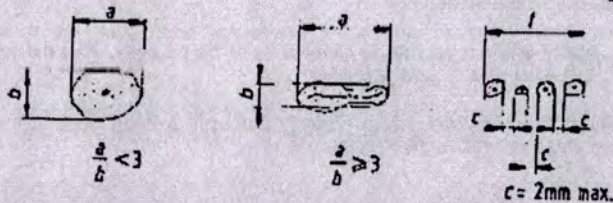
संस्थागत संकेत 	<b>संस्थान मानक (डीप - इरिद्वार)</b> <b>PLANT STANDARD (HEEP - HARDWAR)</b>	<b>HW 0850195</b> पृष्ठ 3 का Page 3 of 11								
SUPERVISORY INVENTORY NO संस्थागत संकेत	<p><b>5. Dye Penetration Testing</b></p> <p><b>5.1 Test Parameters</b></p> <p>The DP testing shall be conducted in accordance with corporate specification AA0850131 using visible dye penetrant. The penetrant, cleaner and developer should match each other. The penetration time shall be between 10-60 minutes.</p> <p>The interpretation of results commences directly after drying of developer. Final evaluation shall be done after at least 10 minutes of developing time. The observations are to be recorded in the test certificate.</p> <p><b>5.2 Assessment of the Results and Acceptance Criteria</b></p> <p>There are no different test classes or areas for Dye penetrant testing. The various types of indications observed in Dye penetrant testing may be classified as shown in Fig. 1</p> <div style="text-align: center;">  </div> <p>Fig 1: a) Circular Indication      b) linear indication      c) linearly aligned indication</p> <p><b>Acceptance Criteria</b></p> <p>The indications except following are acceptable:</p> <ul style="list-style-type: none"> <li>a) No circular indications with a &gt; 4mm. (As defined in Fig 1a)</li> <li>b) No linear indication. (As defined in Fig 1-b) Linear marks between the bearing backing/bearing material on the end faces or joint faces of multilayer plain bearing is only relevant if found by ultrasonic testing. In that case ultrasonic acceptance criteria shall be applicable.</li> <li>c) No linearly aligned indications. (as defined in Fig. 1-c)</li> <li>d) No more than four indications, with a maximum total area of 16mm<sup>2</sup> in area of 10,000 mm<sup>2</sup>. The surface tested may be square or rectangular, with a maximum side length of 250 mm. The defective area considered for evaluation shall be the worst affected area of the total surface under examination.</li> </ul> <p>Clause a) to d) is applicable for DP testing of bearing and thrust bearing pads. Clause a) to c) is applicable for DP testing of seal rings.</p>									
COPYRIGHT AND CONFIDENTIAL The information contained herein is the property of Hindustan Electrols Limited. It must not be used, copied, or reproduced in any form without the prior written consent of the company.										
सत्यापित एवं योग्य प्रो. 2022.4.6.01 2022.4.6.01										
प्रमाणित दिनांक DATE 21/10/2022										
INVENTORY NO <b>P-3041</b>	REV. NO. 02	<table border="1" style="width:100%; border-collapse: collapse;"> <tr> <td style="width:20%;">निर्माता WORKED BY</td> <td style="width:40%;">Sh Kamal Sehgal <i>Kamal Sehgal</i></td> <td style="width:20%;"></td> <td style="width:20%;"></td> </tr> <tr> <td>जांचक CHECKED BY</td> <td>Sh Vivek Mittal <i>Vivek Mittal</i></td> <td>DCM</td> <td>MRL</td> </tr> </table>	निर्माता WORKED BY	Sh Kamal Sehgal <i>Kamal Sehgal</i>			जांचक CHECKED BY	Sh Vivek Mittal <i>Vivek Mittal</i>	DCM	MRL
निर्माता WORKED BY	Sh Kamal Sehgal <i>Kamal Sehgal</i>									
जांचक CHECKED BY	Sh Vivek Mittal <i>Vivek Mittal</i>	DCM	MRL							

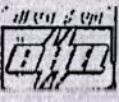
11/11/2022 11/11/2022		<b>संस्थान मानक (डीप - हार्डवयर)</b> <b>PLANT STANDARD (DEEP-HARDWARE)</b>	<b>HW 0850195</b> पृष्ठ का Page 4 of 11										
11/11/2022 11/11/2022	11/11/2022 11/11/2022	<p><b>5.2.1 Micro porosity</b></p> <p>Directly after drying of the developer, observe whether individual indications of size greater than 1.5mm are seen. If so, there must be evaluated as per clause 5.2.1 (d).</p> <p>If the indications are smaller than 1.5 mm, they may be classified as micro porosity, they could lie very close together so that at end of the developing period the whole surface becomes red and distinction of individual defects is no longer possible.</p> <p>If this happens the test surface must be cleaned and examined for visible pores. If no pores are visible without the aid of a magnifying glass then they can be classified as micro porosity.</p> <p>Pores up to a size of 1.0mm visible to the naked eye, are acceptable, if they appear isolated with no linear character with a gap of <math>\leq 2</math> mm from each other. A maximum of four indications in an area of 10,000 mm<sup>2</sup> are acceptable in the worst affected area of the total surface under examination.</p> <p>The feasibility of UT must not be affected by micro porosity. This means bond echoes must be visible in areas with micro porosity.</p> <p>In addition the areas with micro porosity must not exceed 30% of each bearing half and must not show any UT related bonding defects.</p>											
<b>6. Ultrasonic Test</b>		<p><b>6.1 Test Equipment and Probes</b></p> <p><b>6.1.1 Ultrasonic test device:</b> For testing, the ultrasonic equipment shall be such that it conforms to the requirements of corporate standard AA 0850159.</p> <p><b>6.1.2 Probes:</b> The size, frequency and type of probe shall be chosen in relation to the thickness of the bearing layer, backing thickness and backing material. (Ref: Table 1)</p> <p>For babbit thickness greater than 6 mm, a probe of frequency 2 MHz shall be used. If the bearing diameter is less than or equal to 600 mm, the probe used must have a diameter less than or equal to 10 mm.</p>											
<b>Table 1</b>		<table border="1" style="width:100%; border-collapse: collapse; text-align: center;"> <thead> <tr> <th style="width:15%;">Bearing metal thickness (mm)</th> <th style="width:15%;">Backing thickness (steel) (mm)</th> <th style="width:15%;">Probe diameter (mm)</th> <th style="width:15%;">Probe frequency (MHz)</th> <th style="width:15%;">Probe type</th> </tr> </thead> <tbody> <tr> <td>&gt;2</td> <td>20 to 250</td> <td>10 to 30</td> <td>2 to 5</td> <td>Single crystal</td> </tr> </tbody> </table>		Bearing metal thickness (mm)	Backing thickness (steel) (mm)	Probe diameter (mm)	Probe frequency (MHz)	Probe type	>2	20 to 250	10 to 30	2 to 5	Single crystal
Bearing metal thickness (mm)	Backing thickness (steel) (mm)	Probe diameter (mm)	Probe frequency (MHz)	Probe type									
>2	20 to 250	10 to 30	2 to 5	Single crystal									
11/11/2022 11/11/2022	11/11/2022 11/11/2022	<b>REV. NO.</b> 02	11/11/2022 11/11/2022										
11/11/2022 11/11/2022	11/11/2022 11/11/2022	<b>WORKED BY</b> Kamal Sehgal	11/11/2022 11/11/2022										
11/11/2022 11/11/2022	11/11/2022 11/11/2022	<b>CHECKED BY</b> V. V. Mittal	11/11/2022 11/11/2022										
11/11/2022 11/11/2022	11/11/2022 11/11/2022	DGM	MRL										

Pg 01/01

Annexure-C

DOC REV NO.: 0

Page 3 of 3

FIRST ANGLE PROJECTION

**SECTION A-A**

**B-B(32)**  
1:15

**DTEAIL -X**  
1:5

borehole for load shackle occ. to RN693.10 not for ring eye bolts acc. to DIN690 every side 4x

**TECHNICAL REQUIREMENTS:-**

1. FORGING SHALL BE SUPPLIED AS PER SPECIFICATION NO. HW16361.
2. PERMISSIBLE TOLERANCES :-  
ON INSIDE DIMENSION: -2.  
ON OUTSIDE DIMENSION: +2.
3. ○ CHECK DIMENSION
4. ALL NOT DIMENSIONED RADI R2
5. IDENTIFICATION ACCORDING TO HWD400397 AT THE PLACE MARKED WITH IN.

GRADE OF UNTO. DIM		GHS No./ CRIM No.		STATUS		TYPE OF PRODUCT		STEAM TURBINE	
M/CC-C/M/F/AAD230208		01/18/2020		A		OR		NAME OF CUSTOMER/PROJECT	
WELDING-7/172/6AAS2154		01/18/18		A		BHPARAT HEAVY ELECTRICALS LTD		RANPUR, HARIWAR	
GAS CUTTING-73/AAG62110		02/01/18		A		DEPT MTE		SCALE	
						CODE 4300		1:15	
						WEIGHT		2263.00	
						REF. TO ASSY. DRG.			
						TITLE		FORGING FOR	
						BEARING SHELL (ROUGH MACHINED)		CARD NO.	
								2-11836-58999	
								DRAWING NO.	
								2-11836-58999	
								SHEET No. 01	
								No. OF SHEETS 01	
								SIZE A2	

Pradeep Kumar  
(PRADEEP KUMAR)

Singh  
(S.K. Singh)

Singh  
(A.N. Singh)

UNPRICED BID - ANNEXURE-D

Tender Inviting Authority: HERP BHEL VARANASI  
 Name of Work: SUPPLY, INSTALLATION & COMMISSIONING OF CENTRIFUGAL CASTING MACHINE AS PER ANNEXURE-A.  
 Contract No:

PRICE SCHEDULE																					
Sl. No.	Item Description	Item Code / Make	Quantity	Units	NUMBER #	BASIC RATE in Figures To be entered by the Bidder in Rs per unit	NUMBER	P&F (if applicable in %)	NUMBER	F&I (if applicable in %)	NUMBER	GST (If applicable in Percentage)	NUMBER	GST Amount in Rs per unit	NUMBER #	HSN / SAC Code	NUMBER #	TOTAL Amount including taxes in INR	NUMBER #	TOTAL AMOUNT in Words	
1	2	3	4	5	7	8	9	10	11	12	13	14	15	16	17	18	19	20	21	22	
1	SUPPLY OF CENTRIFUGAL CASTING MACHINE AS PER ANNEXURE-A.	RVA210100001	1	SET																	
2	TRAINING COST DURING PDI at VENDORS WORKS as per Clause 7.1 of Annexure-A		1	No.			0.000														
3	TRAINING COST AT BHEL AFTER SUPPLY at BHEL as per Clause 12.6 of Annexure-A		1	No.			0.000														
4	ERECTION & COMMISSIONING	E&C	1	No.																	
Total in Figures																					
Quoted Rate in Figures																					
Quoted Rate in Words																					

  
 (A.N. Singh)

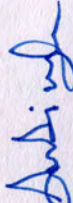
  
 (S.K. Singh)

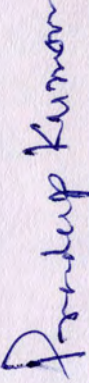
  
 (PRADEEP KUMAR)

TECHNICAL SPECIFICATION			Annexure-A
Heavy Equipment Repair Plant, <b>Bharat Heavy Electricals Limited,</b> Varanasi -221003, Uttar Pradesh, INDIA.		Enquiry No. & Dt.:	
		Due Date :	
		Supplier's Ref.:	
		Date :	
Specification cum Compliance Certificate for CENTRIFUGAL CASTING MACHINE			
NOTES:			
1. The Column " VENDOR'S OFFER WITH TECHNICAL DETAILS & REMARKS" of this format shall be filled in by the Vendor and submitted along with the offer. Inadequate / incomplete, ambiguous or unsustainable information against any of the clauses of the specifications / requirements shall be treated as non-compliance.			
2. The offer and all documents enclosed with offer should be in English language only.			
3. Total No of Machines = 1			
Name & Address of the supplier:		Name & Address of the Indian Agent:	
Telephone No.		Telephone No.	
Fax No.		Fax No.	
e-mail :		e-mail :	
Scope: Supply, Erection & Commissioning of Centrifugal casting machine complying with specification as below.			
SL NO.	BHEL TECHNICAL SPECIFICATION	VENDOR'S OFFER WITH TECHNICAL DETAILS & REMARKS	
1	PURPOSE & WORK PIECE MATERIAL		
	PURPOSE/APPLICATION: The proposed Centrifugal casting Machine shall be required for centrifugal casting of white metal (BABBITT) in Journal bearings of OD upto 1200 mm & final weight (including of casting/forging and babbitt metal) 2500 kgs.	Vendor to confirm	
	The centrifugal casting machine should be specifically designed to safely and economically cast white metal (babbitt) into ferrous or nonferrous housings in the form of bushes, bearings, half shells and shaped shells, using white metals as per specification HW 12897 attached as Annexure-E	Vendor to confirm	
2	SPECIFICATION:		
2.1	MACHINE CONFIGURATION:	Vendor to confirm	
2.1.1	HEAD STOCK		
2.1.1.1	Face Plate diameter	1200 mm or more	
2.1.1.2	Power of Main motor	Vendor to submit details	
2.1.1.3	Spindle Asynchronous motor make, model	Vendor to submit details. Accepted Make are Siemens/ABB/CG/Alstom/	
2.1.1.4	Spindle speed (Infinitely variable)	Vendor to submit details	
2.1.1.5	No. of speed ranges-	Vendor to submit details	
2.1.1.6	Drive mechanism	Vendor to submit details	
2.1.1.7	Torque-Power-Speed characteristics of the spindle system to be submitted by the vendor.	Vendor to submit details	
2.1.1.8	The spindle bearings shall be life time lubricated/selaed	Vendor to submit details	
2.1.1.9	Spindle bearing should be of Make INA/FAFNIR/RHP/FAG/SKF/TIMKEN	Vendor to submit details	
2.1.1.10	Maximum holding OD for largest size bearing	1200 mm or more	
2.1.1.11	Maximum distance between face plates	1000 mm or more	
2.1.1.12	Maximum bearing length	1200 mm or more	
2.1.1.13	Minimum inside diameter after lining	150 mm or less	
2.1.2	TRAVERSES:		
	Longitudinal travel span & joystick/HMI control for movement	Vendor to submit details	
2.1.3	FEED DRIVE SYSTEM, HMI, PLC & MOTORS		
2.1.3.1	VVVF Make & rating for the chuck	Vendor to offer VVVF of Siemens/ABB/Allen Bradley/Schneider only	
2.1.3.2	Chuck/ face plate holding arrangement with details of PCD	Vendor to submit details	
2.1.3.3	Details of mechanism for braking and braking time	Vendor to submit details	
2.1.3.4	Make & model of Spindle motor	ABB/Siemens/CG only	
2.1.3.5	Make & model for Hydraulic motor	ABB/Siemens/CG only	
2.1.3.6	Make & model for motorized guard motor	ABB/Siemens/CG only	
2.1.3.7	Make & model of PLC	Siemens make only	
2.1.3.8	Make and model of HMI	Siemens make only	

Pradeep Kumar  
(PRADEEP KUMAR)

S.K. Singh  
(S.K. Singh)

(A.N. SINGH)

2.1.4	<b>FEED BACK SYSTEM:</b>	Vendor to submit details	
	Feedback system for Spindle rotation RPM through encoder of MAke Heidenhain/Siemens programmed for operation in closed loop	Vendor to submit details	
2.2	<b>CONSTRUCTION:</b>		
2.2.1	Base frame: Fabricated, fully welded and machined heavy duty rectangular hollow section, selected for its rigidity and strength. The base unit should fully support the drive and traversing head.	Vendor to submit details	
2.2.2	Drive head: The drive head should be designed as a single heavy fabricated box frame fully machined to support the drive shaft and support bearings. The frame should be rigid enough to reduce vibration allowing for smooth operation. All bearings should be grease lubricated. Necessary braking arrangement should be available for chuck.	Vendor to submit details	
2.2.3	Traversing head: The traversing head should be designed to allow pouring of the Babbitt or whit metal material.	Vendor to submit details	
2.2.4	Traversing head Support: The traversing head should be designed to clamp the production bearing shell. The movement of the traversing head should be controlled by two hydraulic cylinders giving precise control and smooth operation. The hydraulic cylinders are to be mounted as close to the centreline of the faceplate to facilitate even clamping and pressure	Vendor to submit details	
2.2.5	Clamping system should be hydraulic with three safety systems to prevent ejection of the bearing during production. 1. P.O. check valves in case of hose failure 2. A pre-charged accumulator to maintain pressure in case of power failure. 3. Twin cylinders so if one fails pressure is maintained.	Vendor to submit details	
2.2.6	Faceplates (02 Nos.), which are attached to the drive head and traversing head shafts. The precision machined heavy duty plates should have drilled and tapped holes on various P.C.D. to allow fixing of the bearing shell locators(dogs) to facilitate ease of centering of the bearing shell during production.	Vendor to submit details	
2.2.7	Main Drive required as per standard IEC general purpose motor with IE2/IE3 efficiency to provide infinitely variable speed operating on the frequency operating and adjustment principle. The power should be transferred to the drive shaft by a standard 'V' groove pulley and belt arrangement/ suitable gear box.	Vendor to submit details	
2.2.8	Motorised Stainless steel Guarding: All guards are fully interlocked to prevent machine operation when open.	Vendor to submit details	
2.2.9	Water Cooling & Circulating: A water-cooling system is required as standard, housed within the main guard the cooling system can be made up of more than one bank of nozzles dependent on machine size. All nozzles can be individually turned on or off to suit the bearing configuration. The water cooling should be controlled via the PLC and HMI to provide accurate and repeatable water sequences to improve the bonding of the white metal/ Babbitt to the shell. Necessary arrangement for Water Re-Circulating System, comprising of: Pumps; Filter Radiator Type Heat Exchanger with associated Control Gear may be considered as per design requirement.	Vendor to submit details	
2.2.10	A stainless steel fabricated 2 part pouring funnel/ bucket and spout are located on rails to allow for ease of movement between pouring and pre-heating position. The pouring funnel shall be hinged to aid pre-heating.	Vendor to submit details	
2.3	<b>OPERATION AND CONTROL SYSTEM:</b>		
2.3.1	<b>OPERATOR'S PANEL:</b>		
2.3.1.1	Swiveling type operator's panel/desk mounted system having complete machine control system with display monitor HMI of required configuration shall be provided on the Operators Platform. All switches on the Operator's panel including that for table rotation should be within reach of operator of average Indian height for convenient, efficient & safe operation. All displays/indications should also be conveniently placed accordingly. Layout showing complete details of the panel should be submitted.	Vendor to submit details	
2.3.2	<b>MANUAL CONTROL</b>		
	Complete manual control of machine with required switches / keys should be provided on operator's panel for setting RPM, controlling water cooling jets, automatic opening/closing of motorised guard, clamping using faceplate, hydraulic controls, Alarm/ fault indication. Diagram / Sketches for switches / keys provided on operators pendant should be submitted.	Vendor to confirm. Layout of panel showing requisite switches to be submitted.	
2.4	<b>DIAGNOSTIC SYSTEMS</b>		
2.4.1	HMI with alarm messaging, pictorial display & recipe functionality	Vendor to provide details	
2.4.2	Display of inner ID temperature	Vendor to provide details & confirm	

Pradeep Kumar  
( PRADEEP KUMAR )

Asingh  
(S.K. Singh)

Asingh  
(A.N. Singh)

2.5	AIR CONDITIONERS		
2.5.1	Independent air conditioners with Dehumidifiers of suitable & sufficient capacity to be provided for each Electrical / Electronic Panels / Cabinets including Operator's Panel considering specified ambient conditions. Detailed specifications of the same are to be submitted. Make: ADVANCE/RITTAL/SUNBEAM or equivalent	Vendor to offer & confirm	
2.5.2	In case of order vendor shall provide following information about Air Conditioners and Chiller Unit (s) used in the machine: Type of Refrigeration/ Chiller unit. The Capacity of the chiller unit. Type of compressor with complete specifications. Type of Thermostatic Expansion Valve with complete specifications. Fan size and flow in CFM (cubic feet meter) of the Condenser unit. Specifications of the Evaporator Unit (Width Plate type/ Coil type) Functional requirement of temperature of Cooling Oil to be maintained between range T1 to T2. Type of temperature indicator/ controller used in the chiller unit with complete specifications. Make: ADVANCE/RITTAL/SUNBEAM or equivalent	Vendor to confirm	
2.6	HYDRAULIC SYSTEM (DETAILS TO BE SUBMITTED BY THE VENDOR) :		
2.6.1	The Hydraulic System shall be of Re-Circulating Type. Hydraulic Tank should be preferably placed at shop floor.	Vendor to offer and confirm	
2.6.2	Pumps, Valves, Switches (Pressure & Flow) should be of Make: Rexroth / Vickers/Parker/Hawe	Vendor to offer and confirm	
2.6.3	Filtration System: Sufficient no. of filters (with electric clogging indicator and alarm on PLC) should be used to avoid frequent clogging of the filters and other maintenance related problems. Filter elements should, preferably, be of Make: EPE / Hydac	Vendor to offer and confirm	
2.6.4	Failure indication through LED and indication in HMI	Vendor to offer	
2.6.5	Automatic shut off provision, Details should be submitted.	Vendor to offer	
2.6.6	Refrigerated type cooling and electric heating (Electric heating, only if required) system of sufficient capacity to maintain complete Hydraulic System, including lubrication oil, hydrostatic oil and gearbox oil, etc. keeping in view the specified ambient conditions to be offered with complete details. The temperature of Hydraulic Oil should not go beyond 32 deg. C.	Vendor to offer & submit	
2.6.7	Hydraulic pump capacity (flow / pressure) Make: Duplomatic/YUKEN/Rexroth/HAWE	Vendor to inform	
2.6.8	No Tandem pumps should be used. Maximum desired permissible pressure is 100 Kg/sq.cm. If anywhere, more than 100 Kg/sq.cm pressure is used, then one set of such hose pipes and seal kit of such Hydraulic cylinder should be supplied in spare in addition to other spares.	Vendor to confirm & offer	
2.6.9	Complete hydraulic system should be designed to avoid any leakage or spillage.	Vendor to confirm	
2.6.10	Sufficient stages/nos. of filters should be used to avoid frequent clogging of the filters and other maintenance related problems.	Vendor to offer	
3	ACCESSORIES:		
3.1	White metal holding furnace , manual type, fixed body, capacity dia 400 x 400 mm (Nominal 350 Kg-500 kg)	Vendor to provide details	
3.2	Bottom pour Laddle of 200 kg or more	Vendor to provide details	
3.3	Melting station with 2 Gas burners and complete with Gas control valves	Vendor to provide heating capacity in BTU/Hr	
3.4	Water jet cooling rate programmable and controllable through HMI	Vendor to provide details and list of variable cooling rate range in degrees per Hr.	
3.5	Pouring spout pre heat burner with temperature indication	Vendor to provide heating capacity in BTU/Hr	
3.6	Tinning Bath (Electric) 1200mm x 1200mm x 800mm deep (approx), Complete with Energy and Temperature Controls.	Vendor to offer	
4	ELECTRICAL :		
	415V + 10% / -10%, 50 Hz +/-3 Hz, 3 Phase AC (3 wire system without Neutral) Power Supply will be provided by BHEL at a single point near the machine, as per layout recommended by Vendor. All types of switches, cables, connections, circuit breakers etc. required for connecting BHEL's power supply point to different parts of the machine/control cabinets including shall be supplied by the vendor.	Vendor to offer	
5	SAFETY ARRANGEMENTS (FOLLOWING SAFETY FEATURES IN ADDITION TO OTHER STANDARD SAFETY FEATURES SHOULD BE PROVIDED ON THE MACHINE):	Vendor to offer	
5.1	Machine should have adequate and reliable safety interlocks / devices to avoid damage to the machine, work piece and the operator due to the malfunctioning or mistakes. Machine functions should be continuously monitored and alarm/ warning indications through lights/ alarm number with messages (on HMI display) should be available.	Vendor to offer	
5.2	A detailed list of all alarms / indications provided on machine should be submitted by the supplier.	Vendor to submit	
5.3	All the pipes, cables etc. on the machine should be well supported and protected. These should not create any hindrance to machine operator's movement for effective use of machine.	Vendor to offer	
5.4	All the rotating parts used on machine should be statically & dynamically balanced to avoid undue vibrations & noise.	Vendor to confirm	
5.5	Emergency Switches at suitable locations as per International Norms should be provided.	Vendor to offer	
5.6	Oil & water pipe lines should not run with electrical cable in the same trench.	Vendor to offer	
5.7	Power/hose failure hydraulic safety system	Vendor to offer	
5.8	Fail-safe clamping control.	Vendor to offer	

Pradeep Kumar  
(PRADEEP KUMAR)

Asingh  
(S.K. Singh)

Lat  
(A.N. Singh)

6	PROVE-OUT MACHINING OF BHEL COMPONENT ON MACHINE AT HERP DURING COMMISSIONING	Vendor to offer	
6.1	Drawings of prove out components are enclosed as per Annexure-C. Job prove out shall include pouring of babitt metal as per requirement mentioned in Anexure-C and also detailed in this document under.	Vendor to accept & offer	
6.2	Component Name: Journal bearing 530x530	Vendor to accept & offer	
	Machining Drawing : 01183658000		
	Forging Drawing : 21183658999		
	Raw Material : Low alloy steel forging		
	<u>Pls Note- In case of non-availability of above bearing casting, BHEL will offer a similar bearing of weight between 1 T to 2.5 T and OD less than 1200 mm.</u>		
7	TRAINING & PRE-DISPATCH INSPECTION :		
7.1	Two BHEL Persons should be trained at vendor's works for the area & period given below for 1 week: (a) Process, programming & operation for the machine, measuring system, etc. (b) Maintenance of machine & other supplied equipment (1 week)  Total: 14 Man days of training at OEMs work	Vendor to offer	
	Pre-dispatch inspection of the machine shall also be carried out by the team during their stay at vendor's works for the training in above specified period. BHEL reserves the right to choose no. of persons, field & period of training, out of above, while deputing their engineers for training. <u>BHEL may also waive off the requirement of PDI before dispatch subject to its own discretion (in such case supplier shall arrange for ONLINE PDI / Third party inspection as per BHEL requirement/specification)</u>		
7.2	Air/train-fare, boarding & lodging for the trainees shall be borne by BHEL.	For vendor's information.	
7.3	Competent, English speaking experts shall be arranged by the vendor for satisfactory & effective training of BHEL personnel.	Vendor to accept & confirm	
8	FOUNDATION		
	Vendor shall submit the preliminary General Arrangement Drawing & Layout Drawing for getting BHEL's approval within 30 days from the date of Letter of Intent (LOI) / P.O. Complete Foundation details viz. static / dynamic load details etc. and Final Layout drawings shall be submitted by the supplier within 15 days after getting BHEL's approval. The layout should consist of all requirements pertaining to complete machine including space requirement for Voltage Stabilizer, Isolation Transformer, Air compressor, & all other accessories/ attachments/ offered items. BHEL shall design & construct complete foundation for the machine as per Final Layout & other details provided by vendor. The vendor shall also indicate detailed specifications of grouting compound and grouting procedure etc. if any specifically desired for foundation bolts of the machine. ( Supply of Voltage Stabilizer, Isolation Transformer/ Air compressor shall be in scope of BHEL).	Vendor to accept & offer	
9	ERECTION & COMMISSIONING		
9.1	Supplier to take full responsibility for carrying out the start up, testing of machine, it's control system & all types of other supplied equipment, job prove out etc.	Vendor to accept.	
9.2	Service requirement like power, air & water shall be provided by BHEL at only one point to be indicated by supplier in their foundation/layout drawings. Other requirements like crane and helping personnel shall also be provided by BHEL. Details of these requirements should be informed by vendor in advance. The available crane capacity at the proposed location of the machine will be 75 Ton. The vendor will ensure to make requisite arrangement for lifting of heavier consignment/ items/ assembly of the machine not getting covered by this capacity.		
9.3	Bidder may specify requirement of surface preparation in terms of roughness value necessary during job prove out during installation & commissioning of the machine.	Vendor to offer	
9.4	Successful proving of BHEL components by the supplier shall be considered as part of commissioning for the machine. All tests, as mentioned at Sl. No. 6, 11 & 12 (Machine Acceptance) and testing/demonstration of tele-diagnostic service etc. shall also be part of the commissioning activity.	Vendor to offer	
9.5	Tools, Tackels, Test Mandrels, instruments and other necessary equipment including Laser equipment required to carry out all erection & commissioning activities should be arranged and brought by the supplier.	Vendor to accept	
9.6	Commissioning spares, required for commissioning of the machine within stipulated time, shall be brought by the supplier on returnable basis.	Vendor to accept	
9.7	Schedule of Erection and Commissioning shall be submitted with the offer.	Vendor to submit	
9.8	Terms & conditions for Erection & Commissioning should be furnished in detail separately by vendor along with offer.	Vendor to submit	
9.9	Portion, if any, of the machine, accessories/attachments and other supplied items where paint got rubbed or peeled off during transit or erection should be re-painted and matched with the original adjoining paint by the vendor. For this purpose, the vendor should supply sufficient quantity of touch-up paint of various colours/shades of paints used. The vendor shall ensure performing touching after commissioning but before final acceptance.	Vendor to offer	

Pradeep Kumar  
( PRADEEP KUMAR )

Singh  
( S.K. Singh )

( A.N. Singh )

10	<b>AMBIENT CONDITIONS &amp; THERMAL STABILITY</b>		
10.1	Total machine including all supplied items should work trouble free and should give specified accuracies under existing power supply and ambient operating conditions, as mentioned below.	Vendor to accept & confirm	
10.2	Ambient Operating Conditions: Temperature = 5 to 45-degree Celsius Relative Humidity = 95% max. Weather conditions are tropical. Atmosphere may be dust laden during some part of the year. Machine shall be kept in the normal shop floor condition without any temperature controlled enclosure/shop. Max. temperature variation is 25 deg Celsius in 24 hours.	Vendor to accept	
10.3	Thermal Stability: Thermal Stability of the complete machine and all supplied items keeping in view the specified Ambient Conditions, accuracies, requirements of BHEL components and trouble free operation of the machine should be ensured by vendor. Since the machine shall be installed in shop with operating conditions, the vendor shall ensure minimum bonding required for achieving the acceptable result in UDT.	Vendor to offer & confirm	
11	<b>MACHINE ACCEPTANCE (TESTS/ACTIVITIES TO BE PERFORMED &amp; DEMONSTRATED BY THE VENDOR)</b>	Vendor to note	
11.1	<b>TESTS/ACTIVITIES TO BE CARRIED OUT AT VENDOR'S WORKS ON THE MACHINE BEFORE DISPATCH :</b>	Vendor to note	
11.2	Demonstration of specified/offered capacity of machine	Vendor to accept & confirm	
11.3	The machine should be tested for continuous running of 48 hrs. If any break down occurs during this test, the test should be repeated for 48 hrs from that time.	Vendor to accept & confirm	
11.4	Demonstration of all features of the machine, control system & accessories and trouble shooting	Vendor to accept & confirm	
11.5	NDT of the Rebabitted bearing/test piece shall be carried out as per NDT SPECIFICATION- HW0850195 (attached as Annexure F).	Vendor to accept & confirm	
12	<b>TESTS/ACTIVITIES TO BE CARRIED OUT AT BHEL WORKS WHILE COMMISSIONING THE MACHINE AT HERP.</b>	Vendor to note	
12.1	Demonstration of features, capability of RPM control and variation with load, cooling system etc shall be demonstrated after starting up of machine at HERP.	Vendor to accept & confirm	
12.2	Full load test to demonstrate the maximum power & clamping capacity of the machine.	Vendor to accept & confirm	
12.3	The machine should be tested for continuous running of 48 hrs. If any break down occurs during this test, the test should be repeated for 48 hrs from that time.	Vendor to accept & confirm	
12.4	Demonstration of all features of the machine, control system & accessories, and troubleshooting to the satisfaction of BHEL for efficient and effective use of the machine	Vendor to accept & confirm	
12.5	Demonstration by actual use of all supplied accessories to their full capacity for required applications.	Vendor to accept & confirm	
12.6	BHEL Persons should be trained for the area & period given below for 1 week: (a) Process, programming & operation for the machine, measuring system, etc. (b) Process, Bearing preparation. (c) Babitting process and key control variables. (d) Maintenance of machine & other supplied equipment/accessories	Vendor to accept & confirm	
12.7	Job prove out and testing: NDT of the Rebabitted bearing shall be carried out as per NDT SPECIFICATION- HW0850195 (attached as Annexure F).		
	<b>PACKING</b>		
13.1	Sea worthy & rigid packing for machine, control and all other supplied items to avoid any damage/loss in transit. All small loose items should be suitably packed in boxes	Vendor to offer & confirm	
14	<b>GUARANTEE :</b>		
14.1	Guarantee for complete machine and all supplied systems/accessories / attachments /equipment/items for 24 months from the date of acceptance of the machine.	Vendor to comply	
15	<b>GENERAL :</b>		
15.1	Machine Model	Vendor to specify	
15.2	Total connected load (KVA):	Vendor to specify	
15.3	Floor area required (Length, Width, Height) for complete machine & accessories.	Vendor to specify	
15.4	Painting of Machine / Electrical Panels : (Apple green)	Vendor to confirm	
15.5	Total weight of the machine	Vendor to specify	
15.6	Vendor to submit, along with offer, the reference list of customers where similar machines have been supplied mentioning the customer, Machine Model, major specifications of the supplied machine, CNC System, Year of Supply etc.	Vendor to specify	
15.7	Detailed catalogues, sketch/ photographs of the m/c and accessories/ Attachments should be submitted with the offer.	Vendor to specify	
15.8	Hydraulic, Pneumatic & oil piping's should be preferably metallic except places where flexible piping's are essential. All the pipes required for the same shall be included in the standard scope of the machine.	Vendor to specify	
16	<b>DELIVERY, INSTALLATION &amp; COMMISSIONING SCHEDULE</b>		
16.1	Delivery Schedule- 6 months from the placement of purchase order	vendor to confirm	
16.2	Packing Sea worthy ( For shipment by sea)/Road worthy & rigid packing for machine and all accessories to be provided by vendor to ensure material reaches HERP without any damage	vendor to confirm	
16.3	Installation & commissioning 60 days from the receipt of confirmation of site readiness from BHEL. The site readiness intimation shall be given within 30 days from the receipt of machine (subject to travel restrictions)	vendor to confirm	

Pradeep Kumar  
(PRADEEP KUMAR)

Amit Singh  
(S.K. Singh)

Amit Singh  
(A.N. Singh)

					Annexure-B
 <b>BHARAT HEAVY ELECTRICALS LIMITED</b> UNIT'S ADDRESS: HEAVY EQUIPMENT REPAIR PLANT, TARNA SHIVPUR VARANASI UTTAR PRADESH 221003		Indent No. : Enquiry No. : Due Date : Date :			
CONTACT PERSON FROM PURCHASE DEPT.:		PRE QUALIFYING REQUIREMENT			
ADDRESS OF THE SUPPLIER		ADDRESS OF THE INDIAN AGENT(S) :			
TELEPHONE NOS.:		TELEPHONE NOS.:			
FAX NOS.:		FAX NOS.:			
E-MAIL ADDRESS :		E-MAIL ADDRESS :			
SL. NO.	DESCRIPTION OF BHEL REQUIREMENT	REQUIRED	OFFERED	DEVIATION	REMARKS
A	INDIAN MANUFACTURERS				
1	WORK EXPERIENCE				
1.1	Offers of only Indian Original Equipment manufacturers shall be processed. OEM should have successfully supplied & commissioned at least one no. Centrifugal casting machine suitable for casting of white metal babbitt metal on bearing shell of weight upto 2500 kgs to any reputed organization in world within last 10 years from the date of floating of the NIT. The machine should have been commissioned and working satisfactorily for a minimum 12 months period as on the date of opening of tender. The following information should be submitted by the vendor about the companies where similar machines have been supplied.	Vendor to confirm			
1.1.1	Name of the customer / company, where such machine(s) is(are) installed.	Vendor to submit			
1.1.2	Complete postal address of the customer.	Vendor to submit			
1.1.3	Year of Commissioning.	Vendor to submit			
1.1.4	Application for which the machine is supplied.	Vendor to submit			
1.1.5	Name and designation of the contact person of the customer.	Vendor to submit			
1.1.6	Performance Certificate from the customer regarding satisfactory performance of the machine supplied to them.	Vendor to submit			
2.0	FINANCIAL REQUIREMENT				
2.1	The OEM should have net positive net worth, however CPSE or any central/state government enterprise shall be exempted.	Vendor to submit Certificate from CA for net worth for 17-18,18-19,19-20,20-21.			
2.2	The OEM should submit the audited balance sheet for the F.Y 18-19, 2019-20, 2020-21,2021-22 however CPSE or any central/state government enterprise shall be exempted.	Vendor to submit Audited balance sheet for these four years			
2.3	The OEM should have been in the business of machine building for at least last 4 years i.e. before 31.03.2018	Vendor to certify and submit relevant documents.			
2.3	Vendor to submit MSE, GST, NSIC, UAM certificate & copy of PAN however CPSE or any central/state government enterprise shall be exempted.	Vendor to submit documents			
3.0	CAPABILITY				
3.1	The OEM should have necessary in house fabrication facility for the structure/plates used for manufacturing machine for which details to be submitted or else test certificate of the structural items/plates purchased/imported should be provided at the time of supply of machine.	Vendor to provide details & confirm			
3.2	The OEM should major in house machining facility for manufacturing the machine like Floor borers, milling centers, grinding machines necessary for manufacturing the machine. BHEL may arrange for on site verification of the details through physical/online mode.	Vendor to provide details of machine viz. Make, Model, Working length, capacity, Accuracy etc.			
3.3	The OEM should have qualified technical manpower in the area of CNC application, toolings, load analysis & stability.	Vendor to provide details			
4.0	SELF DECLARATION				
4.1	The OEM should not have been suspended by BHEL or any other CPSE or any government organization and is not guilty by a court of law in India or any other offence involving fraud, dishonesty & moral turpitude, however CPSE or any central/state government enterprise shall be exempted.	Vendor to submit a self declaration certificate			
4.2	The OEM shall submit the self declaration certificate for Make in India as per Make in India (Model Certificate) Annexure-I	Vendor to submit a self declaration certificate			

Pradeep Kumar  
(PRADEEP KUMAR)

Singh  
(S.K. Singh)

(A.N. Singh)

5	<b>PRICE BID</b>			
5.1	The final rate quoted by the bidder must be mentioned under following head	Vendor to confirm that its offer will be rejected if there is any deviation found after opening of price bid. Vendor to fill the unpriced bid		
a	Basic Cost of machine with P&F, Insurance, Taxes clearly specified.			
b	Training of BHEL employees during PDI as per Clause 7.1 of Annexure-A with taxes specified			
d	Training cost as per SI No-12.6 of Annexure-A at BHEL with taxes specified			
e	Installation & commissioning charges with taxes specified			
6	BHEL reserves the right to cancel the tender at any stage without giving any reason.	Vendor to accept		
7	Final price of supply including standard and special tools, erection & commissioning charges, job prove out, training etc will be finalized through the process of reverse auction. Party to submit their acceptance / participate in reverse auction otherwise their offer may not be considered for processing.	Vendor to accept		
8	EMD AMOUNT : Rs.2.00 Lakhs			
8.1	In Order to ensure that the successful bidder / vendor does not refuse to execute the Order, after award of the same on him, each bidder / vendor will be required to furnish Earnest Money Deposit (EMD) along with their tender. EMD by the Tenderer will be forfeited as per Tender Documents if, after opening the tender, the Tenderer on his own makes variation in his earlier quoted rates or revokes/change any other condition of his tender within the validity period.	Vendor to accept		
8.2	Bidders are required to deposit Earnest money deposit through Demand draft or NEFT/RTGS to BHEL Account Bank Name: State Bank of India, IFSC Code: SBIN0000201, Account No: 011103264820, Branch Code: 0201, Address: State Bank of India, Main Branch Kachaheri, Varanasi.	In case of E-Tenders, proof of remittance of EMD should be uploaded in the E-Procurement Portal and originals, as applicable, shall be sent to the officer inviting tender within a reasonable time, failing which the offer is liable to be rejected		
8.3	As per latest Government of India, Ministry of Finance, Department of Expenditure procurement policy division Notification No. F.9/4/2020-PPD dated 30-12-2021, the EMD of successful bidder shall be adjusted against the security deposit / performance bank guarantee which shall be equal to 3% of the value of purchase order. The performance bank guarantee for the balance amount shall be paid by the successful bidder before release of payment against Erection & commissioning. The PBG shall be submitted as per BHEL format and shall be valid for a period of 60 days plus warranty period i.e. 26 months.	Vendor to accept		
8.4	MSE suppliers can avail the intended benefits only if they submit along with offer, attested copies of UDYAM CERTIFICATE along with CA certificate (CA Format enclosed) applicable for the year, certifying quantum of investment in plant and machinery within the permissible limit as per the act for relevant status (Micro or small). Date to be reckoned for determining the deemed validity will be the last date of technical bid submission. Non submission of such documents will lead to consideration of their bids at par with other bidders and MSE status of such suppliers shall be shifted to Non MSE supplier till the supplier submits these documents. EMD is exempted for MSE having UDYAM registration. Vendor to submit covering letter with attested copy of UDYAM along with latest audited CA (Chartered Accountant) Certificate for EMD exemption. CA certificate format is attached with this tender.	Vendor to accept & submit the required documents and certificates		
8.5	Central/State- Public Sector Enterprises shall be exempted from payment of EMD.			
8.6	EMD given by all unsuccessful Tenderer shall be refunded on award of LOI/PO on successful Tenderer. The EMD of successful bidder shall be returned after submission of Order Acknowledgement. EMD shall not carry any interest.	Vendor to accept		
9	Validity of the offer should be 120 days from the date of tender opening. BHEL reserves the right not to consider offers from vendors with validity less than 120 days from the date of tender opening.	Vendor to accept		
10	Warranty Vendor to confirm 24 months warranty from the date of commissioning against workmanship, material used, design and performance.	Vendor to accept		

Pradeep Kumar  
( PRADEEP KUMAR )

Ansingh  
( S.K. Singh )

(A.H. Singh)

**BANK GUARANTEE FOR PERFORMANCE SECURITY**

Bank Guarantee No:

Date:

To  
NAME  
& ADDRESSES OF THE BENEFICIARY

Dear Sirs,

In consideration of Bharat Heavy Electricals Limited (hereinafter referred to as the 'Employer' which expression shall unless repugnant to the context or meaning thereof, include its successors and permitted assigns) incorporated under the Companies Act, 1956 and having its registered office at \_\_\_\_\_<sup>1</sup> through its Unit at \_\_\_\_\_ (name of the Unit) having awarded to (Name of the Vendor / Contractor / Supplier) with its registered office at \_\_\_\_\_<sup>2</sup> hereinafter referred to as the 'Vendor / Contractor / Supplier', which expression shall unless repugnant to the context or meaning thereof, include its successors and permitted assigns), a contract Ref No \_\_\_\_\_ dated \_\_\_\_\_<sup>3</sup> valued at Rs \_\_\_\_\_<sup>4</sup> (Rupees -----)/FC \_\_\_\_\_ (in words \_\_\_\_\_) for \_\_\_\_\_<sup>5</sup> (hereinafter called the 'Contract') and the Vendor / Contractor / Supplier having agreed to provide a Contract Performance Bank Guarantee, equivalent to \_\_\_\_\_ % (\_\_\_\_\_ . Percent) of the said value of the Contract to the Employer for the faithful performance of the Contract,

we, \_\_\_\_\_, (hereinafter referred to as the Bank), having registered/Head office at \_\_\_\_\_ and inter alia a branch at \_\_\_\_\_ being the Guarantor under this Guarantee, hereby, irrevocably and unconditionally undertake to forthwith and immediately pay to the Employer any sum or sums upto a maximum amount of Rs -- -----<sup>6</sup> (Rupees -----) without any demur, immediately on first demand from the Employer and without any reservation, protest, and recourse and without the Employer needing to prove or demonstrate reasons for its such demand.

Any such demand made on the Bank shall be conclusive as regards the amount due and payable by the Bank under this guarantee. However, our liability under this guarantee shall be restricted to an amount not exceeding Rs. \_\_\_\_\_.

We undertake to pay to the Employer any money so demanded notwithstanding any dispute or disputes raised by the Vendor / Contractor / Supplier in any suit or proceeding pending before any Court or Tribunal, Arbitrator or any other authority, our liability under this present being absolute and unequivocal.

The payment so made by us under this Guarantee shall be a valid discharge of our liability for payment thereunder and the Vendor / Contractor / Supplier shall have no claim against us for making such payment.

We the \_\_\_\_\_ bank further agree that the guarantee herein contained shall remain in full force and effect during the period that would be taken for the performance of the said Contract/satisfactory completion of the performance guarantee period as per the terms of the Contract and that it shall continue to be enforceable till

all the dues of the Employer under or by virtue of the said Contract have been fully paid and its claims satisfied or discharged.

We, \_\_\_\_\_ BANK further agree with the Employer that the Employer shall have the fullest liberty without our consent and without affecting in any manner our obligations hereunder to vary any of the terms and conditions of the said Contract or to extend time of performance by the said Vendor / Contractor / Supplier from time to time or to postpone for any time or from time to time any of the powers exercisable by the Employer against the said Vendor / Contractor / Supplier and to forbear or enforce any of the terms and conditions relating to the said Contract and we shall not be relieved from our liability by reason of any such variation, or extension being granted to the said Vendor / Contractor / Supplier or for any forbearance, act or omission on the part of the Employer or any indulgence by the Employer to the said Vendor / Contractor / Supplier or by any such matter or thing whatsoever which under the law relating to sureties would but for this provision have effect of so relieving us.

The Bank also agrees that the Employer at its option shall be entitled to enforce this Guarantee against the Bank as a principal debtor, in the first instance without proceeding against the Vendor / Contractor / Supplier and notwithstanding any security or other guarantee that the Employer may have in relation to the Vendor / Contractor / Supplier's liabilities.

This Guarantee shall remain in force upto and including \_\_\_\_\_<sup>7</sup> and shall be extended from time to time for such period as may be desired by Employer.

This Guarantee shall not be determined or affected by liquidation or winding up, dissolution or change of constitution or insolvency of the Vendor / Contractor / Supplier but shall in all respects and for all purposes be binding and operative until payment of all money payable to the Employer in terms thereof.

Unless a demand or claim under this guarantee is made on us in writing on or before the \_\_\_\_\_<sup>8</sup> we shall be discharged from all liabilities under this guarantee thereafter.

We, \_\_\_\_\_ BANK lastly undertake not to revoke this guarantee during its currency except with the previous consent of the Employer in writing.

Notwithstanding anything to the contrary contained hereinabove:

- a) The liability of the Bank under this Guarantee shall not exceed \_\_\_\_\_<sup>6</sup>
- b) This Guarantee shall be valid up to \_\_\_\_\_<sup>7</sup>
- c) Unless the Bank is served a written claim or demand on or before \_\_\_\_\_<sup>8</sup> all rights under this guarantee shall be forfeited and the Bank shall be relieved and discharged from all liabilities under this guarantee irrespective of whether or not the original bank guarantee is returned to the Bank.

We, \_\_\_\_\_ Bank, have power to issue this Guarantee under law and the undersigned as a duly authorized person has full powers to sign this Guarantee on behalf of the Bank.

For and on behalf of  
(Name of the Bank)

Dated \_\_\_\_\_ .

Place of Issue \_\_\_\_\_ .

<sup>1</sup> NAME AND ADDRESS OF EMPLOYER I.e Bharat Heavy Electricals Limited

<sup>2</sup> NAME AND ADDRESS OF THE VENDOR /CONTRACTOR / SUPPLIER.

<sup>3</sup> DETAILS ABOUT THE NOTICE OF AWARD/CONTRACT REFERENCE

<sup>4</sup> CONTRACT VALUE

<sup>5</sup> PROJECT/SUPPLY DETAILS

<sup>6</sup> BG AMOUNT IN FIGURES AND WORDS

<sup>7</sup> VALIDITY DATE

<sup>8</sup> DATE OF EXPIRY OF CLAIM PERIOD

**Note:**

1. Units are advised that expiry of claim period may be kept 3-6 months after validity date. It may be ensured that the same is in line with the agreement/ contract entered with the Vendor.
2. The BG should be on Non-Judicial Stamp paper/e-stamp paper of appropriate value as per Stamp Act prevailing in the State(s) where the BG is submitted or is to be acted upon or the rate prevailing in the State where the BG was executed, whichever is higher. The Stamp Paper/e-stamp paper shall be purchased in the name of Vendor/Contractor/Supplier /Bank issuing the guarantee.
3. In line with the GCC, SCC or contractual terms, Unit may carry out minor modifications in the Standard BG Formats. If required, such modifications may be carried out after taking up appropriately with the Unit/Region & Law Deptt.

**4. In Case of Bank Guarantees submitted by Foreign Vendors-**

- a. **From Nationalized/Public Sector / Private Sector/ Foreign Banks (BG issued by Branches in India)** can be accepted subject to the condition that the Bank Guarantee should be enforceable in the town/city or at nearest branch where the Unit is located i.e. Demand can be presented at the Branch located in the town/city or at nearest branch where the Unit is located.
- b. **From Foreign Banks (wherein Foreign Vendors intend to provide BG from local branch of the Vendor country's Bank)**
  - b.1 In such cases, in the Tender Enquiry/ Contract itself, it may be clearly specified that Bank Guarantee issued by **any of the Consortium Banks only** will be accepted by BHEL. As such, Foreign Vendor needs to make necessary arrangements for issuance of Counter- Guarantee by Foreign Bank in favour of the Indian Bank & (BHEL & Consortium Bank) branch in India. It is advisable that all charges for issuance of Bank Guarantee/ counter- Guarantee should be borne by the Foreign Vendor. The tender stipulation should clearly specify these requirements.
  - b.2 **In case, Foreign Vendors intend to provide BG from Overseas Branch of our Consortium Bank** (e.g. if a BG is to be issued by SBI Frankfurt), the same is acceptable. However, the procedure at **sl.no. b.1** will required to be followed.
  - b.3 The BG issued may preferably be subject to Uniform Rules for Demand Guarantees (URDG) 758 (as amended from time to time). The BG Format provided to them should clearly specify the same.

<b>List of Consortium Banks ( As on 22.02.2017)</b>			
	<b>Nationalised Banks</b>		<b>Nationalised Banks</b>
1	Allahabad bank	19	Vijaya Bank
2	Andhra bank		<b>Public Sector Banks</b>
3	Bank of Baroda	20	IDBI
4	Canara Bank		<b>Foreign banks</b>
5	Corporation bank	21	CITI Bank N.A
6	Central bank	22	Deutsche Bank AG
7	Indian Bank	23	The Hongkong and Shanghai Banking Corporation Limited
8	Indian Oversea Bank	24	Standard Chartered Bank
9	Oriental bank of Commerce	25	J P Morgan
10	Punjab National Bank		
11	Punjab & Sindh Bank		<b>Private banks</b>
12	State Bank of India	26	Axis Bank
13	State Bank of Hyderabad	27	The Federal Bank Limited
14	Syndicate Bank	28	HDFC
15	State Bank of Travancore	29	Kotak Mahindra Bank
16	UCO Bank	30	ICICI
17	Union Bank of India	31	Indusind Bank
18	United Bank of India	32	Yes Bank

## **GUIDELINES ON ACCEPTANCE OF BANK GUARANTEES GIVEN BY VENDORS**

### **1. INTRODUCTION**

As a part of the business operations, BHEL is taking Bank Guarantees from its Vendors/contractors/sub-contractors for various purposes. These Bank Guarantees are structured according to the terms of the Tender/ Agreement/ Contract.

### **2. TYPES OF BANK GUARANTEES TAKEN FROM VENDORS/CONTRACTORS/ SUB-CONTRACTORS BY BHEL**

Generally, following types of Bank Guarantees are being taken by BHEL-

#### **i. Bank Guarantees for Earnest Money Deposit**

EMD is to be paid by tenderers for securing fulfilment of any obligations in terms of the NIT. In case of total EMD amount is more than Rs.20 lakh, the amount in excess of Rs.20 lakh may be accepted in the form of Bank Guarantee from scheduled bank. The Bank Guarantee in such cases shall be valid for atleast six months.

#### **ii. Bank Guarantee (in lieu of Security Deposit):**

Security Deposit is to be collected from the successful Bidder. In addition to other modes of furnishing Security Deposit, Bank Guarantee from Scheduled Banks can be submitted in lieu of Security Deposit by the contractors/sub-contractors/vendors, subject to the compliance with the provisions of Works Policy/Purchase Policy and/or Tender Conditions/ Extant Guidelines

#### **iii. Bank Guarantee against Mobilization Advance/ Initial/ Milestone linked payment:**

Normally, no advance payment shall be made to Contractor/ sub-contractors/vendors. Mobilization advance payment in exceptional circumstances shall be interest bearing and secured through Bank Guarantee/s and shall be limited to a maximum of 5% of the Contract Value. The Bank Guarantee shall be for 110% of the value of advance so as to enable recovery of not only principal but also the interest portion.

#### **iv. Performance Bank Guarantee:**

These Bank Guarantees may be taken as guarantee for successful performance/ completion of the Contract.

#### **v. Bank Guarantee for Supply of Free Issue Material**

BHEL Units sub-contract their jobs to Ancillaries and other fabricators by issuing materials free of cost on returnable basis. Though these fabricators are under contractual obligation to ensure safety of BHEL material and to return the same after carrying out the assigned job, to safeguard BHEL's interest, Bank Guarantee is to be taken in favour of BHEL.

#### **vi. Bank Guarantee (For release of Liquidated Damages Amount):**

Sometimes, Bank Guarantee against release of Liquidated Damages (LD) is also being obtained by BHEL. In such cases, Bank Guarantee should be valid till the LD issues are settled.

(Compliance with the provisions of Works Policy/Purchase Policy and/or Tender Conditions/ Extant Guidelines may be ensured)

### 3. STANDARD FORMATS

The following standard format for Bank Guarantees for both Indian and foreign contractors/sub-contractors/vendors which can be used by the Units/Regions are enclosed-

- a. Proforma of Bank Guarantee for Earnest Money Deposit (**Annexure A**)
- b. Proforma of Bank Guarantee in lieu of Security Deposit (**Annexure B**)
- c. Proforma of Bank Guarantee (to secure Advance/ Initial/ Milestone linked payment) (**Annexure C**)
- d. Proforma of Bank Guarantee (Performance) / Contract Execution (**Annexure D**)
- e. Proforma of Bank Guarantee (For release of Liquidated Damages Amount) (**Annexure E**)
- f. Proforma of Bank Guarantee for Supply of Free Issue Material (**Annexure F**)

### 4. ACCEPTANCE OF BANK GUARANTEES ISSUED BY CONSORTIUM BANKS

List of Banks in BHEL's Consortium of Banks enclosed at **Annexure 1**. For getting Bank Guarantees issued in BHEL's favor preference shall be given to Consortium Banks. As such, Units should insist their contractors/sub-contractors/vendors to submit Bank Guarantees issued by any of the BHEL's Consortium Banks. Therefore, the List of the Consortium Banks along with the Standard Bank Guarantee Format (forming part of these Guidelines) should also form part of the Tender/ Contract document issued by BHEL. (Units may regularly check Corporate Finance- FSD Site (<http://intranet.bhel.in/FSD>) for updated List of Consortium Banks).

### 5. ACCEPTANCE OF BANK GUARANTEES ISSUED BY NON-CONSORTIUM BANKS

In case any contractors/sub-contractors/vendors expresses difficulty in obtaining Bank Guarantees from any of the BHEL's Consortium Banks and offer to submit Bank Guarantee from any other Nationalized/Public Sector/Private Sector/Foreign Banks, the same may be accepted subject to the following conditions-

#### A. NETWORTH OF THE BANK ISSUING THE BANK GUARANTEE

- i. **In respect of Banks having Net Worth below Rs.500 crores- Exposure Limit is NIL.**
- ii. **In respect of Banks having Net Worth between Rs.500 to Rs. 2000 crores (As per Latest Annual Report)**-The overall exposure limit (at the Unit/Region Level) should not exceed Rs.10 crores for all the non-Consortium Banks put together.
- iii. **In respect of Banks having Net Worth above Rs. 2000 crores (As per Latest Annual Report)**-The overall exposure limit (at the Unit/Region Level) should not exceed Rs.30 crores for all the non-Consortium Banks put together.

Units/ Regions may insist their contractors/sub-contractors/vendors to provide a Certificate from the concerned Bank along with a Copy of latest Annual Report as supporting documents for %Net Worth+ of the Bank. Additionally, in case required, the figure for Net Worth may be cross checked with the Corporate Office/ Head Office of the concerned Bank. In case, the abovementioned limits have already been exhausted or sufficient balance is not available, the same may be intimated suitably to the contractors/sub-contractors/vendors beforehand.

#### B. TYPE OF BANKS ISSUING THE BANK GUARANTEE

- i. **Bank Guarantee submitted by domestic contractors/sub-contractors/vendors from non-consortium banks-**
  1. **Nationalized/ other Public Sector Banks:** Bank Guarantees issued by Nationalized/ other Public Sector Banks (which are not in BHEL's Consortium) can be accepted subject to the condition that the Bank Guarantee should be enforceable in the town/city in which the Unit is located. i.e. Demand can be presented at the Branch located in the town/city in which the Unit is located.
  2. **Private Sector Banks:** Bank Guarantees issued by Private Sector Banks (which are not in BHEL's Consortium) can be accepted subject to the condition that the Bank Guarantee should be enforceable in the town/city in which the Unit is located i.e. Demand can be presented at the Branch located in the town/city in which the Unit is located. However, Units may prefer Nationalized/Public Sector Banks over Private Sector Banks in respect of Bank Guarantees issued by non-consortium banks.

3. **Foreign Banks (BG issued by Branches in India):** Bank Guarantees issued by Foreign Banks (which are not in BHEL's Consortium) can be accepted subject to the condition that the Bank Guarantee should be enforceable in the town/city or at nearest branch where the Unit is located i.e. Demand can be presented at the Branch located in the town/city or at nearest branch where the Unit is located.

4. **Bank Guarantees submitted by Foreign Vendors**

a. **From Nationalized/Public Sector / Private Sector/ Foreign Banks which are not in BHEL's Consortium (BG issued by Branches in India)** can be accepted subject to the condition that the Bank Guarantee should be enforceable in the town/city or at nearest branch where the Unit is located i.e. Demand can be presented at the Branch located in the town/city or at nearest branch where the Unit is located.

b. **From Foreign Banks (wherein Foreign Vendors intend to provide BG from local branch of the Vendor Country's Bank)**

b.1 In such cases, in the Tender Enquiry/ Contract itself, it may be clearly specified that Bank Guarantee issued by any **of the Consortium Banks** will be accepted by BHEL. As such, Foreign Vendor needs to make necessary arrangements for issuance of Counter- Guarantee by Foreign Bank in favour of the Indian Bank (BHEL's Consortium Bank). **It is advisable that all charges for issuance of Bank Guarantee/ counter- Guarantee should be borne by the Foreign Vendor. The tender stipulation should clearly specify these requirements.**

b.2 In case, **Foreign Vendors intend to provide BG from Overseas Branch** of our Consortium Bank (e.g. if a BG is to be issued by SBI Frankfurt), the same is acceptable. However, the procedure at **sl.no. b.1** will required to be followed.

b.3 The BG issued may preferably be subject to Uniform Rules for Demand Guarantees (URDG) 758 (as amended from time to time). In case, of Foreign Vendors, the BG Format provided to them should clearly specify the same.

C. **Co-Operative Banks/ Financial Institutions:** Bank Guarantees issued by Co-Operative Banks/ Financial Institutions is **not to be accepted** under all circumstances.

6. **OTHER IMPORTANT ISSUES-**

i) **BG Text Related Issues-** Bank Guarantees should be clear and precise and should clearly specify the following:

1. The name and address of the applicant i.e Vendor
2. The name and address of the beneficiary i.e BHEL. It must be ensured that the concerned Unit's name is clearly mentioned in the Bank Guarantee.
3. The name and address of the guarantor Bank and Branch
4. A reference number or other information identifying the underlying contract
5. A reference number or other information identifying the issued guarantee.
6. The amount or maximum amount payable and the currency in which it is payable
7. The validity period/date of expiry of the guarantee including Claim period
8. Claim is payable without demur, protest or proof and merely on demand from BHEL. BG should be unconditional
9. It should clearly specify the place of Invocation
10. Presently, there is no legal requirement for getting signatures of Witnesses on the Bank Guarantees. Therefore, BHEL may not insist for the same.
11. In case of cutting/ overwriting on the Bank Guarantee have been properly authenticated under signature and seal of the executing Bank.

## ii) Confirmation of genuineness/authenticity of the Bank Guarantee

Following safeguards in respect of all Bank Guarantees (including Extensions/ Amendments) issued by any of the Banks (including Consortium Banks) are required to be taken .

- a. The prescribed format in which BGs are acceptable from the contractors/sub-contractors/vendors may be formed part of the tender document. On receipt of the Original Bank Guarantee by BHEL, the same may be verified verbatim with the Bank Guarantee format provided by BHEL.

- b. **Use of Structured Financial Messaging System (SFMS) for Sending and receiving Bank Guarantee Instruments**

**Structured Financial Messaging System (SFMS)** has been/ is being implemented by the Banks as per the Ministry of Finance's instructions for Sending and receiving Bank Guarantee and also Inland Letter of Credit Instruments. The SFMS provides a platform for secure communication within the Bank and between Banks. As such, SFMS can prove to be an excellent IT enabled platform for getting secure confirmations from the Banks in respect of Bank Guarantees issued in favor of BHEL. Therefore, Units should insist the contractors/sub-contractors/vendors to provide the Bank Guarantees from Banks which are already SFMS Compliant.

Under SFMS System, a separate advice of the Bank Guarantee (via SFMS IFN 760COV) to be sent to the Advising bank (Beneficiary's Bank) through SFMS by the Issuing Bank (Applicant's Bank), after which the paper Bank Guarantee would become operative. Similar process to be followed for bank guarantee amendment also and separate advice (via SFMS IFN 767COV) is sent to the Advising Bank. It must be ensured that the Issuing and Advising Bank must be SFMS enabled. The details of Advising Bank / Beneficiary Bank (i.e. IFSC Code & Branch address) have to be provided to the BG issuing Bank along with the application for the Application/Request for issuance of Bank Guarantee.

At the time of application for issuance of a Bank Guarantee, the applicant has to furnish Beneficiary's Bank Branch IFSC, Branch Name and address to the Issuing Bank. In this regard, details of those Banks in BHEL's Consortium may be provided to the contractors/sub-contractors/vendors which have waived Advising Charges for advising the Bank Guarantees (where BHEL is beneficiary) through SFMS. Corporate Office will share the details of those Banks from time to time

- c. In case, any contractors/sub-contractors/vendors show their inability to submit the Bank Guarantee from Issuing Bank which is SFMS Compliant, Units may accept paper Bank Guarantee sent to BHEL directly by the issuing Bank under Registered Post (A.D) /Speed Post/Courier/By Hand. However, a declaration as to List of Vendor Banks along with a confirmation that none of their Banks are SFMS compliant may be obtained. Such a requirement shall be clearly specified in the Tender Document/ Contract
- d. In exceptional cases, BGs received through the contractors/sub-contractors/vendors can be accepted. When a Bank Guarantee is directly received through the contractors/sub-contractors/vendors, the Issuing Branch should be requested to immediately send a confirmation that the said Bank Guarantee has been issued by them or send by Registered Post (A.D) an unstamped duplicate copy of the Bank Guarantee directly to BHEL with a Covering Letter. This will enable BHEL to compare the same with the original BG and ensure that the same is in order.
- e. **Further Verification in respect of Bank Guarantees not advised through SFMS**  
As an additional measure of abundant precaution, all the Bank Guarantees received (not advised through SFMS) should be independently verified by BHEL and on receipt of the Original Bank Guarantee, the Issuing Bank may be requested to provide-
  1. Immediate Confirmation over email.

2. The possibility of getting confirmation through digitally signed secured emails from issuing Banks may be explored.
3. Thereafter, Banker may be requested to either provide the Confirmation Letter stating that the said Bank Guarantee has been issued by them and signed by their authorized employees in line with the financial authority/ powers given to these employees, or send by Registered Post (A.D) an unstamped duplicate copy of the Bank Guarantee directly to BHEL with a Covering Letter. Further, a confirmation may be obtained from the Bank that Bank Guarantee has been issued on a Stamp Paper of appropriate value.

All efforts shall be made by the Unit to obtain the confirmation as above within 10 days of receipt of the Bank Guarantees by BHEL.

f. **Additional Safe-guards for all Bank Guarantees (including advised through SFMS)**

The following additional safeguards may please be taken care at the Unit/ Region level in respect of all Bank Guarantees (including Extensions/ Amendments) issued by any of the Banks (including Consortium Banks) to ensure protection of BHEL's interest-

1. Stamp paper related .

- a. Wherever, e-stamping has been made compulsory, it is to be ensured that the Bank Guarantees has been issued in serially numbered security forms/ e-stamping. Verification of e-stamp can be done on-line <http://www.shcilestamp.com> (STOCK HOLDING CORPORATION OF INDIA LIMITED (SHCIL)).

An e-Stamp can be verified online by clicking on verify e-Stamp certificate and entering the following details-

- 1.State
- 2.Certificate Number (UIN)
3. Stamp Duty Type (Description of Document )
4. Certificate Issue Date

- b. The BG Should be on Non-Judicial Stamp paper/e-stamp paper of appropriate value as per Stamp Act prevailing in the State(s) where the BG is submitted or is to be acted upon or the rate prevailing in the State where the BG us executed, whichever is higher.

- c. To ensure that the Stamp Paper is issued in the name of the Issuing Bank or in the name of the Contractor/sub-contractor/ vendor.

2. To ensure that the Bank Guarantees has been issued in serially numbered security forms.
3. As per RBI Guidelines, all Bank guarantees issued for Rs.50,000/- and above should be signed by two officials jointly. Further, the name, designation and code numbers of the officer/officers signing the guarantees should be mentioned under the signature(s) of officials signing the bank guarantee.

- g. **Authorized Officials for dealing with Banks in respect of Bank Guarantees-** Units/Regions to assign responsibility for verification, timely renewal and timely encashment/ invocation of the Bank Guarantees to one or more Finance Executives depending upon the volume of work at the Unit/Region. **All correspondence with the Banks for matters related to Bank Guarantees are required to be carried out by Finance executives only**

iii) **Other issues**

a. **Addition of jurisdiction Clause in the Bank Guarantee-**

**If required, Units/ Region may include the following jurisdiction Clause for dispute resolution at local level**

*" Any claim or dispute arising under the terms of this-Guarantee shall be-subject to the exclusive jurisdiction of-the court at \_\_\_\_\_ (Unit or HQ Location for ex. in case of PSWR - "Nagpur" /PSNR- Delhi, PSER- Kolkata/ PSSR0-Chennai) only.*

However, it may be noted that the exclusive jurisdiction can form a part of the Bank Guarantee formats but it has to be seen that the Court upon whom the exclusive jurisdiction is being conferred must otherwise have jurisdiction for this clause to be effective under law.

**iv) Safe Custody of Bank Guarantees-**

Following steps may be taken by the concerned Finance Officials to ensure safety of Bank Guarantees-

1. Safe custody of the Bank Guarantees shall be the responsibility of Finance executive(s)
2. On receipt of the Bank Guarantee, the complete details of the Bank Guarantee should be entered in BG Register (physical register and also in separate file in soft form) **(As per Format at Annexure 2)** maintained centrally at the Unit/ Region/site. The data entered in the Register should be duly verified by the concerned official/officials.
3. Periodic physical verification and reconciliation of the Paper Bank Guarantees should be done with the BG Register.
4. Original Bank Guarantees including Extensions must be kept in safe Custody in **“Fire Proof”** Cabinets/ Cash Chests.

**v) Long Duration Bank Guarantees**

In case of Long Duration Bank Guarantees, it is advisable that only Bank Guarantees with validity for full period of the contract may be accepted by BHEL.

**vi) Expiry Period and Claim Period**

It may be ensured that the Expiry/Validity date and Claim date mentioned in the Bank Guarantee is in line with the Contract with the vendor.

Further, there should be an adequate gap, preferably 3-6 months, in the Expiry date and Claim Period so as to ensure that sufficient time is available with BHEL to submit Invocation Claim, if required under the Bank Guarantee. BHEL can claim the amount from the bank for the act which has happened before the validity (expiry) date but within the claim period. However, it is advisable that the Invocation Claim may be submitted within the Expiry date.

In this regard, it is to be noted that unless the Bank receives a written claim or demand on or before the Expiry date (in case there is no separate claim date) or Claim date (in case both Expiry date and claim date are included in the text) mentioned in the Bank Guarantee, all the rights of BHEL under the Bank Guarantee shall be forfeited and the Bank shall be relieved and discharged from all liabilities under the said Bank Guarantee irrespective of whether or not the original bank guarantee is returned to the Bank.

**vii) Extension of the Bank Guarantee-**

In case of non-fulfillment or non-completion of the Contractual Commitments by the concerned contractor/sub-contractor/vendor, action for extension of the validity of the Bank Guarantee should be taken atleast 60 days before the Expiry date and in accordance with the terms and conditions of the Bank Guarantee. Commercial/Executing Agency/Construction Manager of the Unit/Region/site concerned should intimate the custodian i.e. Unit's Finance of the Bank Guarantees sufficiently in advance for the action to be taken for Extension of the Bank Guarantee. In case, no response is received by Unit's Finance 60 days before the Expiry Date from the concerned Commercial/Executing Agency/Construction Manager, the concerned Finance Official may take action for extension to ensure that BHEL's interest is safeguarded.

In this regard following points are required to be ensured-

- a. Request for Extension of the validity is to be lodged atleast 60 days before the Expiry Date mentioned in the Bank Guarantee.
- b. The letter seeking extension should be addressed to the contractor/sub-contractor/vendor as the extension is normally done by the Bank on the request of the Applicant (Contractor/sub-contractor/Vendor). The same should be sent through Registered Post with A.D/ Speed Post. Courier/By hand with a copy to the Issuing Bank with a request to invoke Bank Guarantee in case the same is not extended before expiry date and this should be treated as a Provisional Claim.
- c. Regular follow-up with the contractor/sub-contractor/vendor through email/FAX for extension of BG need to be ensured.

- d. In case the extension of the validity is not done 15 days before the expiry date, immediate action for Invocation of the Bank Guarantee should be taken by sending Final Invocation Claim to the Issuing Bank at the place of issue or such other place as is specified in the guarantee with a copy to the contractor/sub-contractor/vendor. All provisions in respect of Invocation Claim as per **Para viii** is required to be followed

#### viii) Invocation Claim

In event of Breach by the contractor/sub-contractor/vendor (s) of the terms and conditions of said Contract or failure of the contractor/sub-contractor/vendor to perform the said Contract for which the Bank Guarantee has been given or in case of failure of the contractor/sub-contractor/vendor to extend the validity of the Bank Guarantee (as per Para vii), the concerned Unit shall take immediate action for lodgment of Claim with the Issuing Bank's Branch for Invocation of Bank Guarantees. Commercial/Executing Agency/Construction Manager of the Unit/Region/site concerned should intimate the custodian of the Bank Guarantees sufficiently in advance for the action to be taken for invocation of the Bank Guarantee.

In this regard, following points may please be ensured-

- a. Invocation Claim is to be lodged well before the Expiry date (in case there is no separate claim date) or Claim date (in case both Validity date and claim date are included in the text) mentioned in the Bank Guarantee.
- b. Invocation Claim is to be typed on BHEL Letter Head with full Postal Address of BHEL's Unit. It should also contain contact details of BHEL's dealing official.
- c. Invocation Claim is to be sent at the place of issue or such other place as is specified in the guarantee. Correctness of Issuing Bank's Address may be ensured before sending the Invocation Claim.
- d. The scanned copy of the Invocation letter may be sent immediately through email followed by sending the Invocation letter by Speed Post/ Registered Post (with Acknowledgement Card)/ By Hand (to be got personally acknowledged) to ensure timely receipt by the Bank's Branch mentioned in the Bank Guarantee. The Acknowledgement/Receipts should be positively obtained and the same should be preserved as evidence of sending Invocation Claim well in time. Confirmation of receipt of the Invocation Letter may be obtained through email or over phone.
- e. Invocation letter should clearly specify the Bank Guarantee Number.
- f. A demand may be made for an amount less than the full amount available (partial demand). Further, more than one demand (multiple demands) upto the total value of Bank Guarantee may be made by BHEL within the validity period. **However, it may be ensured that demand should not be made for more than the amount available under the guarantee as the Bank will consider it a non-complying demand and may not act on the same.**
- g. **It may be noted that Banks, as per the regulations, are required to promptly honour the guarantees issued by them as and when Bank Guarantees are invoked in accordance with the terms and conditions of the guarantee deeds. Payment should be made to the beneficiaries without delay and demur.**

**Under a Bank Guarantee, the Bank undertakes to pay to the beneficiary, any money so demanded notwithstanding any dispute or disputes raised by the of the contractor/sub-contractor/vendor(s) in any suit or proceeding pending before any Court or Tribunal relating thereto and the Banks liability is absolute and unequivocal. As such, the Banks cannot delay and deny honoring the invocation Claim.**

**Therefore, all steps should be taken to ensure timely payment by the Bank.**

- h. In case, the Bank does not act and pay within three working days from the date of presentation of Final Claim/ Demand, the matter may be immediately escalated to the Regional Office of that Bank's Branch and thereafter to their Head Office under intimation to Corporate Office. In case of no response, matter may be referred to Ombudsman, RBI etc.

- i. After one month, if the amount is still not paid, unit may consider filling a legal case against the bank **in consultation with the Corporate Law Department.**

**(Formats for Extension Letter /Invocation Claims are as per Format at Annexure G (1<sup>ST</sup> Letter), Annexure H (Reminder Letter), Annexure I (Final Claim/Invocation Letter) and Annexure J (Invocation Letter))**

**ix) Return of Bank Guarantee**

**a. After Expiry Period**

The Expired Bank Guarantees which are not further required by BHEL due to fulfillment of the Contractual Commitments by the concerned of the contractor/sub-contractor/vendor may be returned to the concerned Bank under intimation to the Vendor/Contractor within 3 months from the date of expiry after ensuring completion of all the activities. The same is to be done on the specific recommendation/ approval of Commercial/Executing Agency/Construction Manager of the Unit/Region/site concerned.

**b. Within Validity Period**

In case, any Bank Guarantee is to be returned by BHEL due to fulfillment of the Contractual Commitments by the concerned of the contractor/sub-contractor/vendor within its validity period, the same has to be done on the specific recommendation/ approval of Commercial/Executing Agency/Construction Manager of the Unit/Region/site concerned after performing due-diligence.

**x) Use of software**

For timely and automatic alert in respect of Bank Guarantees due for expiration, use of software application is advisable. In case, the software is not available at a Unit, the same may be developed in a time bound manner.





**INTEGRITY PACT****Between**

Bharat Heavy Electricals Ltd. (BHEL), a company registered under the Companies Act 1956 and having its registered office at "BHEL House", Siri Fort, New Delhi - 110049 (India) hereinafter referred to as "The Principal", which expression unless repugnant to the context or meaning hereof shall include its successors or assigns of the ONE PART

**and**

\_\_\_\_\_, (description of the party along with address), hereinafter referred to as "The Bidder/ Contractor" which expression unless repugnant to the context or meaning hereof shall include its successors or assigns of the OTHER PART

**Preamble**

The Principal intends to award, under laid-down organizational procedures, contract/s for \_\_\_\_\_

\_\_\_\_\_ (hereinafter referred to as "Contract"). The Principal values full compliance with all relevant laws of the land, rules and regulations, and the principles of economic use of resources, and of fairness and transparency in its relations with its Bidder(s)/ Contractor(s).

In order to achieve these goals, the Principal will appoint panel of Independent External Monitor(s) (IEMs), who will monitor the tender process and the execution of the contract for compliance with the principles mentioned above.

**Section 1- Commitments of the Principal**

- 1.1 The Principal commits itself to take all measures necessary to prevent corruption and to observe the following principles: -
  - 1.1.1 No employee of the Principal, personally or through family members, will in connection with the tender for, or the execution of a contract, demand, take a promise for or accept, for self or third person, any material or immaterial benefit which the person is not legally entitled to.
  - 1.1.2 The Principal will, during the tender process treat all Bidder(s) with equity and reason. The Principal will in particular, before and during the tender process, provide to all Bidder(s) the same information and will not provide to any Bidder(s) confidential/ additional information through which the Bidder(s) could obtain an advantage in relation to the tender process or the contract execution.
  - 1.1.3 The Principal will exclude from the process all known prejudiced persons.
- 1.2 If the Principal obtains information on the conduct of any of its employees which is a penal offence under the Indian Penal Code 1860 and Prevention of Corruption Act 1988 or any other statutory penal enactment, or if there be a substantive suspicion in this regard, the Principal will inform its Vigilance Office and in addition can initiate disciplinary actions.

**Section 2 - Commitments of the Bidder(s)/ Contractor(s)**

- 2.1 The Bidder(s)/ Contractor(s) commit himself to take all measures necessary to prevent corruption. The Bidder(s)/ Contractor(s) commits himself to observe the following principles during participation in the tender process and during the contract execution.

- 2.1.1 The Bidder(s)/ Contractor(s) will not, directly or through any other person or firm, offer, promise or give to the Principal or to any of the Principal's employees involved in the tender process or the execution of the contract or to any third person any material, immaterial or any other benefit which he/ she is not legally entitled to, in order to obtain in exchange any advantage of any kind whatsoever during the tender process or during the execution of the contract.
- 2.1.2 The Bidder(s)/ Contractor(s) will not enter with other Bidder(s) into any illegal or undisclosed agreement or understanding, whether formal or informal. This applies in particular to prices, specifications, certifications, subsidiary contracts, submission or non-submission of bids or any other actions to restrict competitiveness or to introduce cartelization in the bidding process.
- 2.1.3 The Bidder(s)/ Contractor(s) will not commit any penal offence under the relevant Indian Penal Code (IPC) and Prevention of Corruption Act; further the Bidder(s)/ Contractor(s) will not use improperly, for purposes of competition or personal gain, or pass on to others, any information or document provided by the Principal as part of the business relationship, regarding plans, technical proposals and business details, including information contained or transmitted electronically.
- 2.1.4 Foreign Bidder(s)/ Contractor(s) shall disclose the name and address of agents and representatives in India and Indian Bidder(s)/ Contractor(s) to disclose their foreign principals or associates. The Bidder(s)/ Contractor(s) will, when presenting his bid, disclose any and all payments he has made, and is committed to or intends to make to agents, brokers or any other intermediaries in connection with the award of the contract.
- 2.2 The Bidder(s)/ Contractor(s) will not instigate third persons to commit offences outlined above or be an accessory to such offences.
- 2.3 The Bidder(s)/ Contractor(s) shall not approach the Courts while representing the matters to IEMs and shall await their decision in the matter.

### Section 3 - Disqualification from tender process and exclusion from future contracts

If the Bidder(s)/ Contractor(s), before award or during execution has committed a transgression through a violation of Section 2 above, or acts in any other manner such as to put his reliability or credibility in question, the Principal is entitled to disqualify the Bidder(s)/ Contractor(s) from the tender process, terminate the contract, if already awarded, exclude from future business dealings and/ or take action as per the separate "Guidelines on Banning of Business dealings with Suppliers/ Contractors", framed by the Principal.

### Section 4 - Compensation for Damages

- 4.1 If the Principal has disqualified the Bidder (s) from the tender process before award / order acceptance according to Section 3, the Principal is entitled to demand and recover the damages equivalent to Earnest Money Deposit/ Bid Security.
- 4.2 If the Principal is entitled to terminate the Contract according to Section 3, or terminates the Contract in application of Section 3 above, the Bidder(s)/ Contractor (s) transgression through a violation of Section 2 above shall be construed breach of contract and the Principal shall be-entitled to demand and recover from the Contractor an amount equal to 5% of the contract value or the amount equivalent to Security Deposit/ Performance Bank Guarantee, whichever is higher, as damages, in addition to and without prejudice to its right to demand and recover compensation for any other loss or damages specified elsewhere in the contract.

**Section 5 - Previous Transgression**

- 5.1 The Bidder declares that no previous transgressions occurred in the last 3 (three) years with any other company in any country conforming to the anti-corruption approach or with any other Public Sector Enterprise in India that could justify his exclusion from the tender process.
- 5.2 If the Bidder makes incorrect statement on this subject, he can be disqualified from the tender process or the contract, if already awarded, can be terminated for such reason or action can be taken as per the separate "Guidelines on Banning of Business dealings with Suppliers/ Contractors", framed by the Principal.

**Section 6 - Equal treatment of all Bidder (s)/ Contractor (s) / Sub-contractor (s)**

- 6.1 The Principal will enter into Integrity Pacts with identical conditions as this Integrity Pact with all Bidders and Contractors.
- 6.2 In case of Sub-contracting, the Principal Contractor shall take the responsibility of the adoption of Integrity Pact by the Sub-contractor(s) and ensure that all Sub-contractors also sign the Integrity Pact.
- 6.3 The Principal will disqualify from the tender process all Bidders who do not sign this Integrity Pact or violate its provisions.

**Section 7 - Criminal Charges against violating Bidders/ Contractors /Subcontractors**

If the Principal obtains knowledge of conduct of a Bidder, Contractor or Subcontractor, or of an employee or a representative or an associate of a Bidder, Contractor or Subcontractor which constitutes corruption, or if the Principal has substantive suspicion in this regard, the Principal will inform the Vigilance Office.

**Section 8 -Independent External Monitor(s)**

- 8.1 The Principal appoints competent and credible panel of Independent External Monitor (s) (IEMs) for this Integrity Pact. The task of the IEMs is to review independently and objectively, whether and to what extent the parties comply with the obligations under this Integrity Pact.
- 8.2 The IEMs are not subject to instructions by the representatives of the parties and performs his functions neutrally and independently. He reports to the CMD, BHEL.
- 8.3 The IEMs shall be provided access to all documents/ records pertaining to the Contract, for which a complaint or issue is raised before them as and when warranted. However, the documents/records/information having National Security implications and those documents which have been classified as Secret/Top Secret are not to be disclosed.
- 8.4 The Principal will provide to the IEMs sufficient information about all meetings among the parties related to the Contract provided such meetings could have an impact on the contractual relations between the Principal and the Contractor. The parties offer to the IEMs the option to participate in such meetings.

- 8.5 The advisory role of IEMs is envisaged as that of a friend, philosopher and guide. The advice of IEMs would not be legally binding and it is restricted to resolving issues raised by a Bidder regarding any aspect of the tender which allegedly restricts competition or bias towards some Bidders. At the same time, it must be understood that IEMs are not consultants to the Management. Their role is independent in nature and the advice once tendered would not be subject to review at the request of the organization.
- 8.6 For ensuring the desired transparency and objectivity in dealing with the complaints arising out of any tendering process or during execution of Contract, the matter should be examined by the full panel of IEMs jointly, who would look into the records, conduct an investigation, and submit their joint recommendations to the Management.
- 8.7 The IEMs would examine all complaints received by them and give their recommendations/ views to the CMD, BHEL at the earliest. They may also send their report directly to the CVO, in case of suspicion of serious irregularities requiring legal/ administrative action. Only in case of very serious issue having a specific, verifiable Vigilance angle, the matter should be reported directly to the Commission. IEMs will tender their advice on the complaints within 30 days.
- 8.8 The CMD, BHEL shall decide the compensation to be paid to the IEMs and its terms and conditions.
- 8.9 IEMs should examine the process integrity, they are not expected to concern themselves with fixing of responsibility of officers. Complaints alleging mala fide on the part of any officer of the Principal should be looked into by the CVO of the Principal.
- 8.10 If the IEMs have reported to the CMD, BHEL, a substantiated suspicion of an offence under relevant Indian Penal Code / Prevention of Corruption Act, and the CMD, BHEL has not, within reasonable time, taken visible action to proceed against such offence or reported it to the Vigilance Office, the IEMs may also transmit this information directly to the Central Vigilance Commissioner, Government of India.
- 8.11 After award of work, the IEMs shall look into any issue relating to execution of Contract, if specifically raised before them. As an illustrative example, if a Contractor who has been awarded the Contract, during the execution of Contract, raises issue of delayed payment etc. before the IEMs, the same shall be examined by the panel of IEMs. Issues like warranty/ guarantee etc. shall be outside the purview of IEMs.
- 8.12 However, the IEMs may suggest systemic improvements to the management of the Principal, if considered necessary, to bring about transparency, equity and fairness in the system of procurement.
- 8.13 The word 'Monitor' would include both singular and plural.

#### Section 9 - Pact Duration

- 9.1 This Integrity Pact shall be operative from the date this Integrity Pact is signed by both the parties till the final completion of contract for successful Bidder, and for all other Bidders 6 months after the Contract has been awarded. Any violation of the same would entail disqualification of the bidders and exclusion from future business dealings.
- 9.2 If any claim is made/ lodged during currency of this Integrity Pact, the same shall be binding and continue to be valid despite the lapse of this Pact as specified above, unless it is discharged/ determined by the CMD, BHEL.

**Section 10 - Other Provisions**

- 10.1 This Integrity Pact is subject to Indian Laws and exclusive jurisdiction shall be of the competent Courts as indicated in the Tender or Contract, as the case may be.
- 10.2 Changes and supplements as well as termination notices need to be made in writing.
- 10.3 If the Bidder(s)/ Contractor(s) is a partnership or a consortium or a joint venture, this Integrity Pact shall be signed by all partners of the partnership or joint venture or all consortium members.
- 10.4 Should one or several provisions of this Integrity Pact turn out to be invalid, the remainder of this Integrity Pact remains valid. In this case, the parties will strive to come to an agreement to their original intentions.
- 10.5 Only those bidders / contractors who have entered into this Integrity Pact with the Principal would be competent to participate in the bidding. In other words, entering into this Integrity Pact would be a preliminary qualification.
- 10.6 In the event of any dispute between the Principal and Bidder(s)/ Contractor(s) relating to the Contract, in case, both the parties are agreeable, they may try to settle dispute through Mediation before the panel of IEMs in a time bound manner. In case, the dispute remains unresolved even after mediation by the panel of IEMs, either party may take further action as the terms & conditions of the Contract. The fees/expenses on dispute resolution through mediation shall be shared by both the parties. Further, the mediation proceedings shall be confidential in nature and the parties shall keep confidential all matters relating to the mediation proceedings including any settlement agreement arrived at between the parties as outcome of mediation. Any views expressed, suggestions, admissions or proposals etc. made by either party in the course of mediation shall not be relied upon or introduced as evidence in any further arbitral or judicial proceedings, whether or not such proceedings relate to the dispute that is the subject of mediation proceedings. Neither of the parties shall present IEMs as witness in any Alternative Dispute Resolution or judicial proceedings in respect of the dispute that was subject of mediation.

प्रशान्त

For & On behalf of the Principal  
 प्रशान्त सिंह PRASHANT SINGH  
 (Office Seal) Dy. Manager (Purchase)  
 भारत हेवी इलेक्ट्रिकल्स लिमिटेड  
 Bharat Heavy Electricals Limited  
 हरप-वाराणसी/HERP-Varanasi

Place Varanasi  
 Date 19/05/2022

Witness: Praveen Kumar  
 (Name & Address) PRAVEEN KUMAR  
BHEL, HERP.

For & On behalf of the Bidder/ Contractor  
 (Office Seal)

Witness: \_\_\_\_\_  
 (Name & Address) \_\_\_\_\_

Clause on IP in the tender**“Integrity Pact (IP)”**

- (a) IP is a tool to ensure that activities and transactions between the Company and its Bidders/ Contractors are handled in a fair, transparent and corruption free manner. Following Independent External Monitors (IEMs) on the present panel have been appointed by BHEL with the approval of CVC to oversee implementation of IP in BHEL.

Sl	IEM	Email
1.	Shri Arun Chandra Verma, IPS (Retd.)	<a href="mailto:acverma1@gmail.com">acverma1@gmail.com</a>
2.	Shri Virendra Bahadur Singh, IPS (Retd.)	<a href="mailto:vbsinghips@gmail.com">vbsinghips@gmail.com</a>

- (b) The IP as enclosed with the tender is to be submitted (duly signed by authorized signatory) along with techno-commercial bid (Part-I, in case of two/ three part bid). Only those bidders who have entered into such an IP with BHEL would be competent to participate in the bidding. In other words, entering into this Pact would be a preliminary qualification.
- (c) Please refer Section-8 of IP for Role and Responsibilities of IEMs. In case of any complaint arising out of the tendering process, the matter may be referred to any of the above IEM(s). All correspondence with the IEMs shall be done through email only.

Note:

No routine correspondence shall be addressed to the IEM (phone/ post/ email) regarding the clarifications, time extensions or any other administrative queries, etc on the tender issued. All such clarification/ issues shall be addressed directly to the tender issuing (procurement) department's officials whose contact details are provided below:

Details of contact person(s):

(1)  
 Name: Prashant Singh  
 Deptt: Purchase  
 Address: BHEL HERP  
 Phone: (Landline/ Mobile) 9026104315  
 Email: prashants@bhel.in  
 Fax: \_\_\_\_\_

(2)  
 Name: Ashutosh Singh  
 Deptt: Purchase  
 Address: BHEL HERP  
 Phone: (Landline/ Mobile) 8874200847  
 Email: ashutosh@bhel.in  
 Fax: \_\_\_\_\_

On Bidder's office letter pad

## Make in India (Model Certificate) Annexure-I

### Self-Declaration

Enquiry No.	
Enquiry Date	

In line with Government public procurement order Number P-45021/2/2017-B.E-II dated 15.06.2017, and further modified order dt. 28.05.2018, 29.05-2019 and 04.06.2020

I / We hereby declare that I / We are a "Local Supplier" meeting the requirement of minimum local content (.....%) defined in the above government notification for the goods against above mentioned enquiry Number.

Details of location at which local value addition will be made is as follows:

Door No.	
Street / Address 1	
Street / Address 2	
District	
State	
Country	
PIN Code	

We also understand that the false declarations will be considered as breach of Integrity and liable for action.

For Company Name:

Seal:

Signature:

Date:

Place:

(Please fill all Yellow color field )



**Part-III - Vendor Registration Form (SRF)**  
**BHARAT HEAVY ELECTRICALS LIMITED**  
**SUPPLIER REGISTRATION FORM**  
**(INDIAN SUPPLIER)**

Doc. No. AA:SSP:SR:01 Rev:02

Date: 26.09.2016

**Annexure B**

Applicants need to comply with the requirements of the registration process. The information/ documents furnished will be treated in strict confidence.

**Instructions for filling the Registration Form**

- Supplier registration is only through online portal at <https://supplier.bhel.in>.
- All columns in the Registration Form are to be duly filled up. Indicate, '**NIL**'/ '**Not Applicable**', wherever details are not available or not relevant respectively.
- All sheets of the Registration Form are to be signed & stamped/ digitally signed by the authorized signatory.
- Expeditious furnishing of any clarification/ information required during registration to be ensured, failure of which may affect the registration process.
- PO copies/ Experience certificates/ Test certificates or any other required document will be sent for verification to the concerned issuing authority. Registration will be liable to be cancelled if any document is found to be fake/ false/ forged on verification.
- Submission of fake/ false/ forged documents will invite action by BHEL as per extant Guidelines for Suspension of Business Dealings and Fraud Prevention Policy (both as available on [www.bhel.com](http://www.bhel.com)).
- Just submission of supplier registration form does not mean automatic registration. Registration shall be done, after due evaluation and will be intimated accordingly.
- Registration of supplier will be done on the basis of the following criteria depending upon the applicability

SNO	Criteria	Max. Marks	Min. Qualifying Marks	Applicable for
1.	Organizational soundness	50	30	Manufacturers*/ EPC Contractors*/ Non-Manufacturers/ Subcontractor
2.	Financial information			
3.	Quality system	25	15	Manufacturers/ Subcontractor
4.	Technical competence	25	15	
	<b>Total</b>	<b>100</b>	<b>60</b>	

\* Minimum qualifying marks for financial information shall be 10 within the ambit of 30 marks put together for Organisational soundness & Financial information.

- For a document in language other than Hindi/ English, a self-attested Hindi/ English translated document to be attached
- Class 3, Signing & Encryption Digital Signature has to be obtained.

**DECLARATION**

*(This declaration should be signed by the Proprietor/ Partner/ Director)*

I/ We .....declare and confirm that the information furnished and attachments submitted with the application are true and correct. I/ we are aware that any false information provided herein will result in the rejection of my/ our application for registration. I/ we shall be bound by the acts of the duly authorized signatory, who has signed this application and of any other person, who in the future, may be appointed by us in his place, whether or not an intimation of such changes has been given. I/ we undertake to communicate promptly to BHEL any changes in the conditions or working of the firm.

I/ We.....also give the undertaking that BHEL's drawings & specifications shall not be used in any way detrimental to the interest of BHEL and/ or for supply of any material, product or services directly or indirectly to any other customer.

I/ We.....have read and understood that action can be taken as per extant guidelines for Suspension of Business Dealings with Supplier/ Contractor and Fraud Prevention Policy (*both as available on [www.bhel.com](http://www.bhel.com)*).

I/ We .....agree to participate in e-procurement as and when required by BHEL.

Name:

Position:

Date & Place:

Signature along with Office Seal:

- Scanned (Hard/ digitally) copy of declaration signed by the Proprietor/ Partners/ Director and/ or authorized signatory, who has the authority to do so, is to be uploaded.

**BHEL Trained & Certified Assessor**



**Part-III - Vendor Registration Form (SRF)**  
**BHARAT HEAVY ELECTRICALS LIMITED**  
**SUPPLIER REGISTRATION FORM**  
**(INDIAN SUPPLIER)**

Doc. No. AA:SSP:SR:01 Rev:02

Date: 26.09.2016

**PART- A: ORGANISATIONAL SOUNDNESS**

<b>1.0 ORGANISATIONAL INFORMATION</b>						
<b>1.1 NAME AND CORRESPONDENCE ADDRESS OF THE FIRM/ COMPANY TO BE REGISTERED</b>						
<b>1.2 REGISTERED OFFICE ADDRESS</b>						
Tel: Landline			Fax			
Website						
<b>1.3 Address, Contact person &amp; Telephone no for:</b>						
<ul style="list-style-type: none"> <li>• <b>WORKS 1/ DIVISON 1/ BRANCH 1/ SISTER CONCERN 1:</b></li> <li>• <b>WORKS 2/ DIVISON 2 / BRANCH 2/ SISTER CONCERN 2:</b></li> <li>• <b>.....</b></li> <li>• <b>WORKS N/ DIVISON N/ BRANCH N/ SISTER CONCERN N:</b></li> </ul>						
<b>1.4 PRODUCTS/ SYSTEMS/ SERVICES FOR WHICH REGISTRATION IS APPLIED FOR (ATTACH BROCHURES &amp; CATALOGUES)</b>						
SNO	DESCRIPTION	SIZE & RANGE	MANUFACTURING STANDARD (IS/ DIN/ BS/ ASME etc.)	WORKS/ DIVISON ( as per cl 1.3)		
<b>2.0 GENERAL INFORMATION</b>						
<b>2.1 DETAILS OF CHIEF EXECUTIVE:</b>			<b>2.2 DETAILS OF AUTHORISED SIGNATORY ATTACH AUTHORIZATION LETTER)</b>		<b>2.3 DETAILS OF CONTACT PERSON FOR ANY CLARIFICATION (S)</b>	
Name						
Designation						
Aadhar No.						
E-Mail						
Tel: Landline						
Mobile						
Fax						
<b>2.4 DETAILS OF DIRECTORS IN CASE OF PRIVATE LTD., ONE PERSON COMPANY, PUBLIC LTD. AND PARTNERS IN CASE OF LIMITED LIABILITY PARTNERSHIP/ PARTNERSHIP FIRMS, OFFICE BEARERS IN CASE OF CO-OPERATIVE SOCIETY, TRUSTEES IN CASE OF TRUST, PROPRIETOR IN CASE OF PROPRIETORSHIP FIRM, Karta of HUF:</b>						
Name	Gender (Male/ Female)	% Share of Ownership	SC/ ST (Y/ N)	PAN	Aadhar No.	DIN No. (if applicable)



**Part-III - Vendor Registration Form (SRF)**  
**BHARAT HEAVY ELECTRICALS LIMITED**  
**SUPPLIER REGISTRATION FORM**  
**(INDIAN SUPPLIER)**

Doc. No. AA:SSP:SR:01 Rev:02

Date: 26.09.2016

amdt. 03 dated 12.10.2020

**Annexure-C**

(Attach organization chart)					
<b>2.5 DIRECTORS / PARTNERS/ PROPRIETOR, IF RELATED TO ANY BHEL EMPLOYEE.</b>		<b>2.6 IF ANY EX-BHEL PERSONNEL IS EMPLOYED/ ENGAGED BY THE COMPANY</b>		<b>2.7 DETAILS OF FAMILY MEMBERS, RELATED FIRMS, GROUP COMPANIES ETC. REGISTERED WITH BHEL</b>	
Name of BHEL Employee		Name of Ex. BHEL Employee		Name of The Firm/ Family Member	
Staff No.& Designation		Staff No.& last Designation held		Nature of Business	
Unit & Department		Place of last posting (Unit & Dept.)		Relationship	
Relationship		Date of leaving Service from BHEL		Whether registered in same material category for which application submitted.	
<b>3.0 OWNERSHIP INFORMATION (DOCUMENTS TO BE FURNISHED)</b>					
<b>3.1 OWNERSHIP</b>			<b>DOCUMENTS TO BE FURNISHED</b>		
Govt. Of India Undertaking			-		
State Govt. Undertaking			-		
Public Limited Company			Memorandum of Association, Articles of Association and Certificate of Incorporation		
Private Limited Company					
One Person Company					
Limited Liability Partnership			Memorandum of Association, Articles of Association, LLP partnership agreement, Certificate of Incorporation (LLPIN)		
Partnership Firm			Registered Partnership Deed duly signed by Registrar of Firms		
Proprietorship			Profession Tax Regn./ Municipal Regn/ PAN of Firm (Proprietor)		
Co-Operative Society			Certificate of Registration of society issued by Registrar of Societies along with its Society Rules and Bye Laws ( as per Extant Act)		
Trust			Registered Trust Deed		
Others (please specify)			Attach a copy of the relevant Statutory document		
Any other Statutory document need to carry out business (please specify)					
<b>3.2 Nature of Business</b>					
Tick as applicable:					
<ul style="list-style-type: none"> <li>• Manufacturer / Engg. Consultant/ EPC Contractor/ System Integrator (            )</li> <li>• Subcontractor - Machinist / Fabricator with free issue of material (            )</li> <li>• Dealer*/ Trader*/ Distributor*/ Stockist*/ Channel Partner*/ Indian sales office* or subsidiary of registered Foreign Principal* etc. (attach authorization certificate of Principal) (            )</li> <li>• Indian Agents* (attach authorization certificate of principal, third party business rating report of foreign principal from Dun &amp; Bradstreet/ Creditreform etc. &amp; deed of agency agreement) (            )</li> </ul>					
*Non-Manufacturer needs to submit an Authorization Certificate, clearly indicating the validity period as well as rights granted by respective OEMs to them i.e. to negotiate/ quote/ supply/ after sales service etc. in line with scope matrix submitted.					
<b>3.3 Year of Commencement of Business (attach relevant documents)</b>					

**SUPPLIER'S AUTHORIZED SIGNATORY**

**BHEL Trained & Certified Assessor**



**Part-III - Vendor Registration Form (SRF)**  
**BHARAT HEAVY ELECTRICALS LIMITED**  
**SUPPLIER REGISTRATION FORM**  
**(INDIAN SUPPLIER)**

Doc. No. AA:SSP:SR:01 Rev:02

Date: 26.09.2016

<b>4.0 REGISTRATION PARTICULARS (COPY OF RELEVANT DOCUMENTS TO BE ATTACHED)</b>		
<b>4.1</b>	Permanent Account No (PAN)	
<b>4.2</b>	Central Sales Tax Regn. Number / TIN Number	
<b>4.3</b>	State Sales Tax/ VAT / TIN Number	
<b>4.4</b>	Excise Control Code number	
<b>4.5</b>	Service Tax Regn. Number	
<b>4.6</b>	Whether Company is Micro/ Small Enterprise (MSE) Category	YES/ NO
<b>4.6.1</b>	Category as per extant MSME Act (Micro/ Small/ Medium)	
Documents to be furnished (any one) & (Tick the appropriate) <ul style="list-style-type: none"> <li>• Udyog Aadhaar Memorandum &amp; Acknowledgement</li> <li>• Valid NSIC Certificate ( )</li> <li>• Entrepreneurs Memorandum part II (EM II) certificate (deemed validity of 5 years) ( )                {in case of EM II certificate older than 5 Years, EM II certificate along with attested copy of CA certificate* applicable for the relevant financial year (latest audited)} ( )</li> </ul> * Certificate by Chartered Accountant on letter head as per <i>Annexure-H</i>		
<b>4.6.2</b>	MSE Ownership w.r.t. SC/ ST, if applicable, documents to be furnished (Tick the appropriate)	
<ul style="list-style-type: none"> <li>• Proprietor: SC/ ST Certificate ( )</li> <li>• Partnership Firm: SC/ ST Certificate of partners holding 51% shares &amp; above ( )</li> <li>• Limited Company: SC/ ST Certificate of Directors/ Owners holding 51% shares &amp; above ( )</li> </ul>		
<b>5.0 OTHER PARTICULARS (DOCUMENTS TO BE FURNISHED)</b>		
<b>5.1 IF REGISTERED WITH ANY OF BHEL UNITS</b>		
Name of BHEL unit		
Common/ Unit Supplier Identification (ID)Number		
Items for which supplier is registered & their specifications (copy of at least one or more successfully executed purchase orders)		
<b>5.1.1 IF ANY OF YOUR SISTER UNIT/ FIRM IS REGISTERED FOR SIMILAR ITEM/S?</b>		
Name of Sister Unit(s) already registered with BHEL		
Common/ Unit Supplier Identification(ID)Number/ Code		
Item/s for which supplier is registered	Item 1	Item 2
<b>5.2</b> Whether approved by <b>ASME / NTPC/ NPC/ EIL/ DGS&amp;D/ RAILWAYS/ IBR/ LLOYDS/ ONGC/ PGCIL/ BARC/ RITES/ IOCL/ PDIL/ CPWD/ Any other CPSU</b> for similar items, for which registration is sought?	YES/ NO (Documentary Evidence)	
<b>5.3</b> Whether Supplier is <b>ISO 9001</b> Certified	YES/ NO (Certificate)	
<b>5.4</b> Whether Supplier is <b>ISO 14000</b> Certified	YES/ NO (Certificate)	
<b>5.5</b> Whether Supplier is <b>OHSAS 18000</b> Certified	YES/ NO (Certificate)	
<b>5.6 Experience List:</b>		
Attach list of present customers with name & address for offered/ similar type & size of item/ equipment for which registration has been sought and with whom applicant has continuous business since last three years. Copies of latest previous two purchase orders executed to be attached.  (Attach performance certificates issued by its customers for successful execution of the contracts)		
<b>5.7</b> Details of Pending Legal/ Arbitrations issues on contractual aspects with customer, if any? (If Yes, kindly furnish details with latest status on a separate sheet)		YES/ NO



**Part-III - Vendor Registration Form (SRF)**  
**BHARAT HEAVY ELECTRICALS LIMITED**  
**SUPPLIER REGISTRATION FORM**  
**(INDIAN SUPPLIER)**

Doc. No. AA:SSP:SR:01 Rev:02

Date: 26.09.2016

**6.0 MANUFACTURING FACILITIES:**

**6.1 LIST OF MANUFACTURING FACILITIES/EQUIPMENTS INCLUDING MATERIAL HANDLING FACILITY (RELATED TO THE ITEMS APPLIED FOR REGISTRATION)**

Sl. No	Works/ Division (as per cl. 1.)	Description of Machine/Equipment	Quantity	Make & Year of Installation	Remarks

In case of space limitation, please enclose annexure / catalogue with tag

**6.2 IF IN-HOUSE MFG FACILITIES NOT AVAILABLE, INFORM SOURCE OF MFG. DETAILS ALONG WITH THEIR FACILITIES (RELATED TO THE ITEMS APPLIED FOR REGISTRATION)**

Sl. No	Process Outsourced	Name & address of The Company	Description of Machine / Equipment	Remarks

In case of space limitation enclose annexure/ catalogue with tag

**6.3 RATIO OF OUTSOURCED COST TO TOTAL PRODUCTION VALUE: \_\_\_\_\_.**

**6.4 POWER BACK UP (Furnish details on separate sheet) YES/ NO**

**7.0 INSPECTION & TESTING FACILITIES**

**7.1 LIST OF INSPECTION & TESTING FACILITIES / EQUIPMENT AVAILABLE (RELATED TO THE ITEMS APPLIED FOR REGISTRATION)**

Sl. No	Works/ Division(as per cl. 1.2)	Description of Facility/ Equipment & Capacity	Nos.	Make & Year of Manufacturing	Last Date of Calibration(With Traceability)

In case of space limitation enclose annexure/ catalogue with tag

**7.2 IF IN-HOUSE TESTING FACILITIES NOT AVAILABLE, INDICATE SOURCE OF TESTING ALONGWITH THEIR FACILITIES (RELATED TO THE ITEMS APPLIED FOR REGISTRATION)**

Sl. No	Test	Source of Testing	Description of Facility/ Equipment & Capacity	Approval of Equipment/ Process/ Personnel Qualification

In case of space limitation enclose annexure/ catalogue with tag

**Note:** In case of outsourcing of major testing such as NDT, Electrical & Mechanical Testing, no marks will be awarded. However, material composition testing by chemical method from recognized laboratory shall not attract negative marking.



**Part-III - Vendor Registration Form (SRF)**  
**BHARAT HEAVY ELECTRICALS LIMITED**  
**SUPPLIER REGISTRATION FORM**  
**(INDIAN SUPPLIER)**

Doc. No. AA:SSP:SR:01 Rev:02

Date: 26.09.2016

**PART- B: FINANCIAL INFORMATION (to be certified by a Chartered Accountant)**

1. Audited copies of annual reports/ complete set of annual accounts for the last four years (or from date of incorporation whichever is less) are to be submitted. 2. If the supplier is new in business and does not have past data, then the financial evaluation will be done on the basis of information provided. 3. Scanned copy of the financial information as below signed by a Chartered Accountant is to be uploaded.					
<b>FINANCIAL INFORMATION FOR THE PREVIOUS FOUR YEARS</b> <b>“Figures to be as per Revised Schedule 6 of the Companies Act 2013, as applicable”</b>					
8.0	Parameter	Year 1	Year 2	Year 3	Year 4
(Years in ascending order, Money value in Rs. Lakhs )					
8.1	NET WORTH (Share Capital + Reserves)				
8.2	LONG TERM DEBT/ LOAN				
8.3	DEBT EQUITY RATIO <u>Long term Debt (8.2)</u> Net worth (8.1)				
8.4	INVESTMENT IN: Land & Building				
	Plant & Machinery				
	Other Fixed Assets				
8.5	NET CURRENT ASSETS				
	1 a) Cash on hand				
	b) Account receivable				
	c) Inventories				
	d) Loans and advances				
	e) Other current assets				
	<b>Total</b>				
8.5	CURRENT LIABILITY & PROVISIONS				
	2 a) Sundry creditors				
	b) Advances from customers				
	c) Other liabilities				
	d) Provisions				
<b>Total</b>					
8.5	QUICK RATIO				
	3 <u>CA - Inventory {8.5(1)-</u> <u>8.5(1)c}/</u> <u>Current liability {8.5 (2)}</u>				
8.6	SALES (excluding other income)				
8.7	PROFIT BEFORE TAX				
8.8	Contingent Liabilities				
8.9	Whether the supplier has been referred to BIFR/ NCLT/ any other Govt agency ( If YES, enclose details)				YES / NO
8.10	Whether the supplier is a potential sick company.( If YES, enclose details)				YES / NO

**Date:**

**Name:**

**Membership number & Seal of Chartered Accountant**

**Signature -----**

**SUPPLIER'S AUTHORIZED SIGNATORY**

**BHEL Trained & Certified Assessor**

**Part C: (QUALITY SYSTEM):**

9.0	Parameters	System in effect (tick if exists & provide evidences if ticked in written procedure)		Records (tick if available & submit evidence)	Remark / Relevant documents to be furnished
		Written Procedure	Practice		
9.1	Incoming Material Control System				System and documentary evidence of control over sub-suppliers in the form of Quality Plan/ Checklist (Customer Hold Point (CHP), In-Stage Inspection etc.)
9.2.1	In Process Control				Work instructions/ checklist/ job card & record of process control parameter
9.2.2	Control on Outsourced Processes, if applicable				Documentary evidence of control over suppliers in the form of Quality Plan/ Checklist (Customer Hold Point (CHP), In-Stage Inspection etc.)
9.3	Manufacturing Process/ Testing Procedure Qualification				Copy of Manufacturing process work flow/ Testing Procedure Qualification
9.4	Personnel qualification for cl. 9.3 (above).				Copy of Record of Personnel qualification for critical processes (welding, painting, NDT etc.)
9.5	Calibration system				Copy of list of instruments & their calibration status(certificate from NABL/ any other Govt. approved & accredited lab)
9.6	System of Identification & Traceability of materials, tools, jigs, fixtures & processed components, etc.				Copy of procedure
9.7	System of Storage, Preservation, Painting & packing				Copy of procedure
9.8	System of Non Conformity Report (NCR) disposition, corrective and preventive action (CAPA)				Copy of System for NCR handling and list of NCRs observed in the last three years along with details of disposition and CAPA.
9.9	Customer complaints (CC) handling system, CC disposition, corrective and preventive action (CAPA)				Copy of System for CC handling and list of customer complaints in the last three years along with details of disposition and CAPA.
9.10	Safety measures				Copy of safety procedure/ guideline & Record of accidents for last three years.
9.11	Any other quality initiative				

**Part D: TECHNICAL COMPETENCE (MARKS SHEET)**

Technical competence shall be evaluated in two parts viz. common competence and product/ material category/ item specific competence.

**a) COMMON TECHNICAL COMPETENCE**

TECHNICAL COMPETENCE ( where design specification is given by BHEL )	MARKING RANGE	Marking range, if product specific technical competency not required	Supplier to attach supporting documents	Marks by BHEL
Supplier understands the product specification.	(0-3)	(0-8)	e.g. Technical Catalogue	
Supplier understands the inspection requirements.	(0-2)	(0-5)	e.g. Inspection Report	
Supplier has process capability to achieve the product specification/dimensional requirement.	(0-3)	(0-8)	e.g. Type test report	
Supplier has experienced manpower to carry out the job.	(0-2)	(0-4)	e.g. skill matrix of the personnel	
<b>TOTAL MARKS OUT OF POSSIBLE</b>	<b>10</b>	<b>25</b>		

**OR**

TECHNICAL COMPETENCE (where performance specification is given by BHEL)	MARKING RANGE	Marking range, if product specific technical competency not required	PROCEDURE		SYSTEM IN EFFECT		RECORDS	
			Supplier to attach supporting documents	Marks by BHEL	Supplier to attach supporting documents	Marks by BHEL	Supplier to attach supporting documents	Marks by BHEL
Design capability	(0-3)	(0-8)						
Adequacy of quality assurance plan	(0-2)	(0-5)						
Process capability for components	(0-3)	(0-8)						
Adequacy of testing facilities	(0-2)	(0-4)						
<b>TOTAL MARKS OUT OF POSSIBLE</b>	<b>10</b>	<b>25</b>						
<b>Average of Total (Total/3) = -----</b>								

**b) PRODUCT/ MATERIAL CATEGORY/ ITEM SPECIFIC TECHNICAL COMPETENCE**

**(Max. marks 15)**

Unit MISCC to structure the parameters to be considered for technical competence and score of individual parameter depending on material category/ item. MISCC shall identify the requirement of enclosures to be furnished by supplier.

Product:

SNO	Material category/ item	Tech Parameter	Supplier's response with relevant documents	Remarks

To be filled up by supplier only on receipt of technical requirements/ Specification/ Drawings/ Standards from BHEL and to be sent to BHEL for further scrutiny.