



---

**INVITATION TO TENDER**

---

**Ref.: OS/22-23/7914/DST&DH/15/016**

**Date: 24.11.2022**

**Sub: Fabrication of Deaerator Storage Tank, Deaerator Heater and Loose Items against S.O. 7914 inside premises of BHEL – HPVP, Visakhapatnam**

---

Dear Sir,

Sealed tenders are invited for the subject work in **two part bid** system from Vendors who are experienced in fabrication of similar jobs and fulfil the eligibility criteria specified below in clause-1. Scope of work and techno-commercial terms and conditions are as follows.

**1. ELIGIBILITY CRITERIA:**

- 1.1 Bidders shall be **IBR approved** and must have an experience of executing similar works (i.e., Fabrication of Deaerator Storage Tank and Heater or Similar Equipments) during the past 7 Years as on 31.10.2022. Bidders shall enclose Work Order, Work/Job Completion Certificates, IBR registration document and all other relevant documents in support of their experience in execution of similar job for at least one project.
  - 1.2 Bidders shall also have to enclose the documents of Registration of Firm/ Factory License/ Certificate of Incorporation, valid IBR Registration certificate, EPF, ESI, PAN, GSTIN, Udyog Aadhar Memorandum (if registered with MSME) etc.
  - 1.3 The works executed in own name of the individual / firm of the tenderer will only be considered for eligibility criteria.
- 

**2. LOCATION OF WORK SPOT:**

- 2.1) The fabrication work is to be carried out inside premises of BHEL-HPVP, Visakhapatnam.

**3. SCOPE OF WORK:** Detailed scope of the fabrication work will be as follows:

The Details of the Equipments to be fabricated is given at Annexure-II and briefed below:

<u>Sl. No.</u>	<u>S.O. No.</u>	<u>Description of Item</u>	<u>Qty.</u>	<u>Total Wt.</u>
1.	7914	Deaerator Storage Tank in 3 sections & Loose items	1 Set	170 MT
2.	7914	Deaerator Heater	1 Set	<u>55 MT</u>
				<b><u>225 MT</u></b>

***It may be noted that the weight indicated above is tentative and may vary on both sides due to revision in the drawings, if any.***

- 3.1) Complete Fabrication of Deaerator Storage tank in 3 sections, Deaerator Heater and Loose Items which includes Marking, Cutting, Machining, Drilling, Rolling, Re-rolling, Assembly, Fit-up, Welding & Dressing, NDT, Local SR, Hydro-test, Stage wise & Final IBR Inspection, Blasting & Painting etc., as per the approved Drawings, QAP / ITP, WPS, Procedures, Painting Schedule, IBR Specifications & Standards and loading of the equipments onto the trailer. It includes the following activities but not limited to the same:
  - 3.1.1) Collection of all free issue items (Raw materials & BOCs) from HPVP Shops / Stores and transportation to fabrication yard and Unloading the same at site.
  - 3.1.2) Fabrication involves operations like Marking, Cutting, Machining, Drilling, Rolling, Re-rolling, Assembly, Fit-up, Welding & dressing, NDT like LPI, MPI, Radiography, Hydro-testing etc. as per approved drawings & QAP.
  - 3.1.3) Rolling of shell segments of Deaerator Storage Tank and Heater as per approved drawings & QAP.

- 3.1.4) Height marking, Edge Preparation, Assembly, welding, NDT etc., of Dished ends with Shells along with Production Test Coupons as per approved drawings & QAP.  
**Supply of Formed Dished ends and Spherical Dishes including NDT (DP& UT) and normalizing is in BHEL scope.**
- 3.1.5) Fabrication of External & Internal attachments like Stiffeners, Manhole Assemblies, Spider Assembly, Vortex Breaker, Support Rings, Pipe Davits, Manhole doors, Stiffener rings, Pipe supports, RF Pads, Lifting Trunions / Lugs, Nozzle assemblies with pipes & pipe fittings, Saddles, Instrument Tappings etc., including Marking, Cutting, Rolling / pressing of plates, fit-up, Welding, NDT etc., as per approved drawings & QAP.
- 3.1.6) Fabrication and Fixing of CS / SS internals and Loose items as per approved drawings & QAP.
- 3.1.7) Transportation of Deaerator Storage Tank sections and Deaerator Heater Shell with one Dished end in welded condition & closing dished end in tack welded condition to HPVP shops for SR and back to fabrication site after SR.
- 3.1.8) Template of Down Comer Nozzles is also to be fabricated by the vendor
- 3.1.9) Local SR of Closing C-seam of Deaerator Heater.
- 3.1.10) Hydro-test is to be carried out for Deaerator Heater and Stand Pipe Assembly at Test pressure specified in the drawings followed by Draining, Drying & Cleaning. Water will be made available at one point and laying of necessary piping for filling has to be arranged by Vendor. Arranging of all the accessories required for the Hydro-test like Filling Pump, Pressurizing Pump, Calibrated Pressure Gauges including fabrication of Stems for Fixing of Pressure Gauges, Non-Return Valves etc. is in the vendor's scope. Water available at ADM site is to be tested at NABL approved laboratory for its suitability for Hydro-test to meet the Specifications and if not suitable, the required water has to be arranged by the Vendor in Tankers.
- 3.1.11) Surface preparation by Blast Cleaning and Coating of Primer & Finish Paints as per approved Painting Schedule/ Standards & specifications of BHEL, Hyderabad. All tests required as per Job Specifications and BHEL Painting Procedure shall be carried out by a qualified agency for testing of painting and obtaining stage wise inspection clearance from HPVP (QC) / TPIA / IBR as per approved drawings & QAP.
- 3.1.12) Painting is to be carried out only by Painters qualified by HPVP as per standard format.
- 3.1.13) Letter painting of Dispatch particulars in a prescribed / specified format.
- 3.1.14) Loading of finished equipments onto the trailer using BHEL crane by providing necessary manpower, tools & tackles and Welding of all temporary supports required for transportation of the same to the customer.
- 3.1.15) Final IBR documents including issuance of Form II (2), III and IVA from DCIB & DOB is in vendor's scope.
- 3.1.16) The IBR inspection fees is to be paid by the vendor.
- 3.1.17) All consumables like Electrodes & Filler wires, Gases, Grinding wheels etc., required for fabrication are in the scope of the Vendor. The electrodes / filler wire shall be of BHEL approved makes only and the vendor shall submit the Batch Test Certificates to BHEL for verification before using on the job.
- 3.1.18) Welding is to be carried out by IBR qualified welders only. Qualification of welders, if required, shall be carried out by the vendor at their cost. However, Test samples shall be provided by BHEL as free issue.
- 3.1.19) Submission of economic cutting plans for the plate materials and approval shall be obtained from BHEL-HPVP before taking up fabrication. Wherever fabrication is done without proper approved cutting plans, any loss of materials arising due to the same will be recovered as per BHEL recovery rates.
- 3.1.20) **Sectional bending of structural items wherever required.**
- 3.1.21) Free issue items cleared by QC (Stores) to be collected within 3 days from the date of intimation without any failure.
- 3.1.22) Hydra crane of suitable capacity, Chains / Slings required for shifting, fabrication, loading & unloading etc., is in the scope of vendor. BHEL-HPVP will provide 75 MT crane as per the requirement where Hydra crane will not serve the purpose. One helper is to be deployed by vendor on daily basis for upkeep maintenance of 75 MT crane. **Non-deployment of Helper will attract deduction of Helper charges in RA Bills.**

- 3.1.23) Vendor shall take up all the equipments simultaneously and engage sufficient man power separately for each equipment to meet HPVP delivery schedules.
- 3.1.24) Experienced Site-in-charge and Qualified Engineers & Supervisors shall be deployed for proper co-ordination of the job.
- 3.1.25) Vendors should deploy Experienced & Qualified QC personnel for carrying out the inspection activities in coordination with BHEL QC inspector / TPIA / IBR. **Non-deployment will attract penalty @ rate decided by BHEL and same will be deducted in RA Bills.**
- 3.1.26) Vendors should deploy Qualified NDT personnel (Level III / Level II) at site for carrying out the NDT inspection activities in coordination with BHEL QC –NDT / TPIA / IBR. Vendors shall have to engage sufficient man power and resources for fabrication to meet HPVP delivery schedules. **Non-deployment will attract penalty @rate decided by BHEL and same will be deducted in RA Bills**
- 3.1.27) Vendor shall deploy sufficient no. of calibrated Welding machines, Main Ovens & Portable Ovens required for baking of electrodes, other machinery at site. All relevant documents shall also be made available for verification & approval by BHEL - HPVP (QC) / TPIA/ IBR.
- 3.1.28) Sufficient No. of Rollers & Idlers required for fabrication of Vessel have to be arranged by the vendor. **Non-deployment in specified time will attract penalty @rate decided by BHEL and same will be deducted in RA Bills.**
- 3.1.29) Required tools & tackles like Measuring instruments like Tape, Fillet & Butt Weld Gauges, Plumb bobs with magnets, Thermal Chalks / Pyrometer etc., shall be calibrated and valid calibration certificates must be presented, if required.
- 3.1.30) Temporary shed for Painting: Temporary shed for Grit Blasting and painting is to be constructed by the Vendor at his own cost. Land required for the same will be provided inside the HPVP premises and development of the same construction of the shed to be done by the vendor. All Scaffolding materials like Pipes, Clamps, GI sheets etc., required for closed enclosure are to be arranged by Vendor. Painting of all the structural items, which are to be sent loose, to be done in this shed only. Transportation of the same from the fabrication yards to shed to be done by vendor.  
If the shed is not constructed by vendor within dates mutually discussed and agreed time, BHEL will exercise the right to execute the same at the risk and cost of the vendor.
- 3.1.31) All the Scaffolding materials like Pipes, Clamps, Jallies etc., for temporary platform works required during the complete course of the fabrication, blasting and painting are to be arranged by the Vendor. All the Temporary materials & Bed materials required for fabrication are to be arranged by the vendor at their cost.
- 3.1.32) No extra rates are applicable for the additional joints to be made in Plates /Pipes/ Rolled sections.
- 3.1.33) Equipment details shall be hard stamped by encircling with paint and stencilled in a specific format with details of Project name, Customer No., Work Order No., PGMA No., Weight etc., for identification and dispatch as per the instructions of the outsourcing department. Fixing of Name plate, engraving / punching as per the details given in the drawings and rub-off.
- 3.1.34) Gate passes for the entry of Manpower, Materials, Cranes, Trailers etc., inside the premises of BHEL-HPVP are to be taken care by the contractor.
- 3.1.35) Power will be provided at one point to the Vendor as Free Issue. Arrangement of Power Distribution Board with suitable capacity Switch Fuse unit as incomer, all outgoing with necessary safe trips like MCB, ELCB etc., as per the industrial safety norms and their installation, all outgoing cables from Distribution Board, termination at the distribution board, cabling for the distribution of Power & Working Area Lighting. Sufficient Area lighting at the work place shall be arranged by the vendor at their cost.
- 3.1.36) Vendor's scope shall include arranging & laying of cables, arranging Distribution Boards with suitable capacity Switch Fuse units as incomer, all outgoing with necessary safe trips like MCB, ELCB etc., as per the industrial safety norms and their installation, all outgoing cables from Distribution Board, termination at the distribution board, Working Area Lighting.

- 3.1.37) Vendors shall have to return the excess / balance materials including off-cuts and total scrap available with the vendors exclusive of process allowance & invisible wastage to HPVP Stores after material reconciliation but before submission of their final bill. In case the same are not returned by the vendor, Recovery shall be made as per BHEL Rates / MSTC rates plus applicable taxes, prevailing at the time of processing of the final bills.
- 3.1.38) Any modification work due to revision of drawings during fabrication is to be carried out by the vendor without any extra cost.
- 3.1.39) Though not mentioned specifically, any activity which is required for completion of the work is deemed to be included in the scope of work of vendor.

**4. BHEL SCOPE:** BHEL – HPVP shall provide the following as free issue:

- 4.1) Drawings, GMS, QAP, WPS, Painting Schedule, applicable Procedures, Standards & Specifications.
- 4.2) Raw materials like full / off-cuts Plates, Pipes & Tubes, Round Bars, Structural items etc., Paints and BOCs like Pipe Fittings, Nozzles, Flanges, Fasteners, Gaskets, Trays, Spray Nozzles etc., as per GMS from HPVP stores. Transportation of these materials from BHEL-HPVP stores/shops to Fabrication yard is in vendor's scope.
- 4.3) Formed Dished ends and Spherical Dishes including NDT (DP & UT) and normalizing is in BHEL scope.
- 4.4) Blind Flanges / Blind covers, Gaskets and Fasteners required for Hydro-test.
- 4.5) SR of Deaerator Storage Tank in 3 sections and Deaerator Heater Shell with one Dished end in welded condition & closing dished end in tack welded condition will be done in BHEL-HPVP shops. However, Transportation of the vessels from fabrication site to HPVP shops and back to fabrication site after SR is in vendor's scope.
- 4.6) 75 MT crane along with operator will be provided by BHEL free of charge for fabrication wherever Hydra crane arranged by the vendor will not serve the purpose. Maintenance of the BHEL crane including spares shall be in the scope of BHEL. However, Riggers required for handling the job shall be provided by the vendor. Diesel required for the operation of BHEL crane will be Free Issue by BHEL. **One helper is to be deployed by vendor on daily basis for upkeep maintenance of 75 MT crane.**
- 4.7) Area required for fabrication, site office and Stores at fabrication site will be provided free of charge. All other arrangements for site enabling including Jungle Clearance & Surface Levelling etc., if required, shall be done by the vendor only.
- 4.8) Power shall be provided free of charge at one point but further distribution to the desired location is in vendor's scope. In case of power failure, the vendor has to make alternative arrangement without any extra cost to BHEL.

**5. INSPECTION:**

- 5.1) Inspection shall be carried out by M/s. BHEL-HPVP, Vizag / BHEL Authorized Inspection Agency (TPIA) / Customer & IBR as per approved QAP. Vendor's scope includes co-ordination with IBR officials for Stage wise & Final Inspection and obtaining inspection clearances before proceeding for further operations along with all necessary documentation.
- 5.2) Fabrication Vendor shall be solely responsible for preparation and submission of all Inspection Reports & documents duly certified by Inspection Authority along with the finished equipments.
- 5.3) All the documentation related to inspection clearance of M/s. BHEL/TPIA/Customer & IBR, Generation of Inspection Reports, Preparation of Final Documents as per BHEL standard formats, Final IBR documents including issuance of Form II (2), III and IVA from DCIB & DOB etc., are included in the scope of vendor and scanned copy as well as hard copy of the same is to be submitted to BHEL-QA. The IBR inspection fees is to be paid by the vendor.

**Note:**

QAP / MQP enclosed with the tender document is tentative only and may be subject to revision due to incorporation of comments of the approving authority. Hence, the approved QAP / MQP issued to the vendor after ordering shall only be followed for execution and inspection of the job.

**6. DELIVERY:**

- 6.1) Fabricated equipments & loose items along with inspection documents and all other relevant certificates are to be handed over to HPVP- Logistics at fabrication site as per the instructions at the time of delivery and as per the following schedule:

**Within 12 weeks from the date of issue of First consignment of free issue materials or 6 weeks from the date of issue of Last consignment of materials, whichever is later.**

**Note:** a) Time schedule is very stringent and Vendor has to deliver the job as per Customer requirement and schedule which will be meticulously monitored by BHEL/Customer. All necessary steps to reduce the cycle time for the individual sub-activities and main activities will be mutually discussed and Vendor has to mobilize additional resources as per time to time requirement to achieve the same.

b) For intermediate operations like SR, the time period from the date of handing over to the date of taking over will be excluded from the delivery period for the purpose of computation of LD.

c) In case the delivery period offered by the vendor is more than the tender delivery, Price quoted by the bidder shall be loaded for additional period @1/2 % per week or part thereof for the purpose of evaluation of Bidder Status.

**7. SITE MOBILISATION:**

- 7.1) Successful bidders shall have to complete site mobilization within 7 days from the date of receipt of order or from the date of intimation for the same by BHEL whichever is later.

**8. PRICE:**

- 8.1) The price shall be quoted strictly as per the Schedule of Rates enclosed at Annexure – I for the detailed scope of work and the quoted price shall be inclusive of all applicable taxes & duties except GST.

- 8.2) The prices shall be fixed & firm without any escalation during the entire period of contract and till completion of the work.

- 8.3) GST shall be reimbursable to the vendor as detailed in Clause - 9 and as per Annexure – GST.

- 8.4) Income tax will be deducted at applicable rates from RA & Final bills.

**9. GOODS & SERVICES TAX (GST):**

- 9.1) Bidders shall make a note of the following points of GST before submission of their offer:

a) Vendors shall have to mention their GSTIN no. (15 Digits) in their Technical Bid. If any specific exemption is available, a declaration with due supporting documents need to be furnished for considering the offer.

b) Semi-finished goods are to be delivered by the Vendors in BHEL, HPVP premises within a maximum period of one year from the date of issue of the material, failing which the whole transaction will be considered as Supply & Sale and GST is required to be paid along with interest (calculated @ SBI Base Rate + 6%) along with penalty, if any, from the date of Challan on the whole value of materials. Hence vendors shall have to ensure that materials issued to them are returned within 365 days.

c) After fabrication, the vendors shall have to deliver the Semi - finished Goods by fulfilling the following formalities:

i) GST invoice should be raised by the vendors by paying GST on job work charges at applicable rates and by incorporating the HPVP GSTIN no. in the invoice for availing the reimbursement of GST from HPVP.

ii) The vendor shall also have to enter in their GST Return -1 (GSTR-1) the details of invoice raised for payment of GST so as to enable HPVP to avail input credit.

**10. REVERSE AUCTION:**

- 10.1) BHEL shall be resorting to Reverse Auction (RA) for this tender. RA shall be conducted among the techno-commercially qualified bidders. Business Rules for Reverse Auction are given at Annexure – V and Guidelines for Reverse Auction are available on our website, [www.bhel.com](http://www.bhel.com) → supplier registration → Guidelines for Reverse Auction 2021, before submission of their offer.

- 10.2) Sealed envelope / Electronic Price bids of all the techno-commercially qualified bidders shall be opened and the same shall be considered as initial bids of the bidders in RA. In case any bidder(s) do(es) not participate in online Reverse Auction, their sealed envelope price bid along with applicable loading, if any, shall be considered for ranking.

- 10.3) BHEL will inform bidders the details of service provider who will provide business rules, all necessary training and assistance before commencement of online bidding. The bidders participating in the Reverse Auction shall have to necessarily submit '**Process Compliance Form**' (PCF) to the designated Service Provider.
- 10.4) Bidders are advised to read the 'Business Rules' (Annexure – V) indicating details of RA event carefully, before reverse auction event.

11. Other Terms & Conditions, whichever applicable, shall be as per Annexure – III enclosed.

**12. RISK PURCHASE:**

In case the contractor fails to execute the work within the scheduled time or due to any other reasons, BHEL - HPVP reserves the right to get the same completed through some other party at the risk & cost of the contractor and any additional expenditure incurred due to the same shall be charged to the contractor.

**13. VALIDITY OF OFFER:**

The offer shall be valid for a period of **3 months** from the date of Reverse Auction.

**14. GENERAL:**

- 14.1) The bidders shall study the Tender documents, Drawings, Quality Documents and all other relevant documents in detail for understanding the scope of work and the processes involved before submission of offer. Bidders shall get clarifications, if any, from concerned officials on the scope of work or any other details of the tender document, over phone between 09:00 AM and 04:00 PM on any working day or through e-mail.
- 14.2) Drawings, QAP, WPS, other reference documents etc., shall be sent to vendor's e-mail address on e-mail request by the bidder.
- 14.3) **Conditional / Partial Price Bids** and any other deviations to the tender terms & conditions are not acceptable and BHEL reserves the right to reject such offers without further correspondence. Bidders shall confirm their acceptance to all the terms & conditions of the tender enquiry in the Techno-commercial Bids and any deviations mentioned in the Price Bids shall not be considered.
- 14.4) BHEL reserves the right to modify or cancel the tender enquiry at any stage without assigning any reasons thereof.
- 14.5) The General Terms & Conditions, if any, contradicting with the specific terms & conditions given in the tender, then specific terms & conditions shall only be considered.
15. The following documents shall form part of the tender enquiry:
- i) Schedule of Rates : Annexure – I
  - ii) List of Reference Drawings & Documents : Annexure – II
  - iii) General Terms & Conditions : Annexure – III
  - iv) Acceptance to tender terms & conditions : Annexure – IV
  - v) Business Rules for Reverse Auction : Annexure – V
  - vi) GST Compliance for Indigenous Suppliers : Annexure – GST
  - vii) Drawings, QAP / MQP etc.

**16. TENDER SUBMISSION (Through E - Mail):**

- 16.1) Techno-commercial bids along with the tender document duly signed by the bidder on all pages and a covering letter on Company's Letter Head addressed to Sr. DGM (Outsourcing), BHEL-HPVP, Visakhapatnam shall be sent through an e-mail to **technicalbid-hpvp@bhel.in**.
- 16.2) Price bid (i.e., Annexure – I) shall also be sent separately through e-mail to another e-mail ID **pricebid-hpvp@bhel.in**.
- 16.3) Offers completed in all respects along with the supporting documents shall be sent through the above e-mails only latest by **14.00 Hrs. on 05.12.2022** duly mentioning the Name of Work, Tender Ref. No. & Date and Technical Bid / Price Bid in the subject of the e-mail.

**Note: Do not mark CC and BCC while submitting your offer as the system is designed to reject such mails having more than one recipient. Max. file size of the attachment shall be 20 MB only. In case the file size is more, bidder can submit their offer through multiple mails within the due date and time.**

16.4) TENDERS RECEIVED AFTER THE DUE DATE & TIME ARE NOT ACCEPTABLE.

16.5) OFFERS SENT IN ANY OTHER FORM WILL BE TREATED AS INVALID AND WILL BE SUMMARILY REJECTED.

**17. TENDER OPENING:**

17.1) Techno-commercial Bids will be opened at **14.00 Hrs.** on **05.12.2022**. The bidders may depute their representatives at the time of opening of Technical bids.

17.2) After evaluation of the Techno-commercial Bids, intimation regarding date & procedure of conducting reverse auction shall be given by the service provider to all the eligible techno-commercially qualified bidders through an e-mail in advance at an appropriate time.

**For Bharat Heavy Electricals Limited,**



श्री पी.एन.एच.एल. लि. सी.ए.ओ. P. RAO  
उप महा प्रबन्धक (ओ एल)/Dy.GM (OS)  
बी.एच.ई.एल., एच.पी.वी./BHEL-HPVP,  
विशाखपट्टणम/VISAKHAPATNAM-530 012

**SCHEDULE OF RATES**

Tender Enquiry Ref: OS/22-23/7914/DST&amp;DH/15/016

Date : 24.11.2022

Sub: Fabrication of Deaerator Storage Tank, Deaerator Heater and Loose Items against S.O. 7914 inside premises of BHEL – HPVP, Visakhapatnam

Sl. No.	S.O. No.	Description of Work	Unit	Qty.	Unit Rate (in ₹)	Total Amount (in ₹)
		Fabrication of Deaerator Storage Tank in 3 sections, Deaerator Heater and Loose Items as per the Drawings, Specifications, QAP & WPS with free issue materials / items including Collection of FIMs from HPVP stores / shops and transportation to fabrication site, NDT, Hydrotesting of Heater, Blasting, Painting etc. Transportation of Storage tank shell sections & Heater from fabrication site to Shops for SR and back to fabrication site, Handing over of the finished equipments to HPVP Logistics dept. and loading of equipments onto the trailers & welding of supports for transportation etc., complete in all respects as per the detailed scope of work.  (All Electrodes & Filler wires required for fabrication is in vendor's scope)				
1	7914	Deaerator Storage Tank in 3 sections and Loose Items	MT	170		
2		Deaerator Heater assembly	MT	55		
		<b>TOTAL</b>	<b>MT</b>	<b>225</b>		
<b>Amount in Words :</b>						

**Notes :**

- 1) **L1 Status will be evaluated on the Total Quoted Value.**
- 2) The quoted price shall be inclusive of all applicable taxes & duties except GST. Income Tax shall be deducted at applicable rates from RA & Final Bills and GST shall be reimbursable to the vendor as per applicable guidelines.
- 3) The prices shall be fixed & firm without any escalation during the entire period of contract and till completion of work.
- 4) The quantity and weights indicated above are approximate and may vary on both sides subject to revision or addition or deletion of drawings. However, payment shall be made for the actual weights as per the applicable drawings / BOM.
- 5) The bidders are advised to go through all the drawings & documents before quoting the tender.
- 6) The evaluation currency for this tender shall be **INR**.
- 7) Tenderer should quote the amount in figures & words. It may be noted that corrections, overwriting etc. are not allowed. If there is a discrepancy between amount in figures & words, the amount in words shall prevail unless the amount expressed in words is related to an arithmetic error, in which case the amount in figures shall prevail. If there is an error in the total corresponding to the addition or subtraction of sub-totals, the sub-totals shall prevail and total shall be corrected accordingly.

In case of mismatch between rate and amount in figures, rate in figures shall be taken into consideration for further evaluation and processing.

---

**Signature of the Bidder with stamp**

Tender Enquiry Ref: OS/22-23/7914/DST&amp;DH/15/016

Date : 24.11.2022

Sub : Fabrication of Deaerator Storage Tank, Deaerator Heater and Loose Items against S.O. 7914 inside premises of BHEL – HPVP, Visakhapatnam

**DETAILS OF EQUIPMENTS TO BE FABRICATED**

Sl. No.	S.O. No.	PGMA	Description of Item	Qty.	Unit	GA Drawing / Rev. No.
1	7914	01-000 & 03-000	Deaerator Storage Tank in 3 sections and Loose Items	170	MT	3-163-11-14121, REV.0
						4-163-10-00684, REV.0
						4-163-10-00617, REV.1
2		02-000	Deaerator Heater	55	MT	3-163-16-11664, REV.0
						3-163-16-11828, REV.0
						3-163-16-11829, REV.0
	4-163-11-14135, REV.2					
	4-163-16-13270, REV.0					
		MQP			HYQA/SSMQP/HE/510/50 97 REV.02	
			<b>Total</b>	<b>225</b>	<b>MT</b>	

Note : The above weights are approximate and may vary as per the drawings issued at the time of order / execution.

**GENERAL TERMS & CONDITIONS****1. TECHNICAL DELIVERY CONDITIONS:**

The work should conform to the technical data given in our drawings, GMS, Shipping List Specifications, QAP, WPS etc.

**2. PARTY'S SCOPE:**

The scope of the party shall be as follows: -

- a) All welding equipments, baking oven, tools, jigs and fixtures, measuring instruments duly calibrated, handling facilities, testing facilities etc.
- b) All materials other than those mentioned under "Free Issue Materials", which are required for completion of the work.
- c) All consumables such as electrodes, gases, grinding wheels etc.

**Note: Electrodes of specification mentioned in the drawings / WPS and of BHEL approved brands only shall be used and MTCs of the same shall be submitted to BHEL for verification before use.**

**3. REVISION OF DRAWINGS:**

There may be minor changes in the drawings during execution. In such a case, party should accommodate the same without any extra claim.

**4. WELDING QUALIFICATION:** Qualification of required number of Welders is party's responsibility at their cost.**5. X-RAY:**

All welding shall be of X-ray quality where specified on drawings. Inspection would specify the quantum of X-ray based on drawings / code requirement. Party should strictly follow the WPS and QAP issued by BHEL during welding. Getting the welds radiographed and getting them cleared by inspection is the responsibility of the party.

**6. RECTIFICATIONS / REJECTIONS:**

Any rectification due to defective work, if required, shall be done by the party free of charge with a suitable technology approved before hand by BHEL in writing. The cost of material, if any used for rectification work / rejection work, will be estimated by BHEL and the same shall be debited to party's account. In case any rectification / rework is to be carried out due to defective material supplied by BHEL, the replacement material and consumables will be supplied by BHEL free of Cost.

**7. SECURITY DEPOSIT:**

Vendors shall have to submit a Bank Guarantee for **10%** of the order value in case of **HPVP ADM site** or **25%** of the material cost in case of Vendor works towards Security Deposit and safe custody of free issue materials within 15 days from the date of intimation by Outsourcing dept. The BG shall be valid for the contract period with a claim period of 12 months. This Bank Guarantee shall be released to the contractor after completion of work and on acceptance of the same by BHEL / Owner

Bidder agrees to submit performance security required for execution of the contract within the time period mentioned above. In case of delay in submission of performance security, enhanced performance security which would include interest (SBI rate + 6%) for the delayed period, shall be submitted by the bidder. Further, if performance security is not submitted till such time the first bill becomes due, the amount of performance security due shall be recovered as per terms defined in NIT/contract, from the bills along with due interest.

**8. PERFORMANCE BANK GUARANTEE:**

Vendors shall have to submit Performance Bank Guarantee (claim period of 12 months) for 10% of the order value covering for the defects liability period. If PBG is not submitted, 10% of the order value shall be deducted towards PBG from the final bill and shall be refundable after performance guarantee period, if no defects are found during this period.

**9. RAW MATERIALS ISSUE:**

Raw materials shall be issued with appropriate processing allowance and invisible wastage over the theoretical requirement of raw materials (**Plates, Sheets, Sections and Pipes**).

**10. TRANSFER / RETURN OF LEFT OVER MATERIALS:**

Party should maintain proper records for receipt & use of all free issue materials. The left over materials & scrap as per the material accounting statement shall be returned to HPVP stores along with finished job. Material Transfer Vouchers (MTV) from one order to another or from one vendor to another and Material Return Vouchers should be submitted immediately after transfer / return. The material reconciliation statement shall be submitted by the contractor after verification and certification by BHEL along with the final bill **within 30 days from the date of completion of work**. Otherwise, recovery for the balance materials shall be made from any of their pending bills without further intimation.

**11. MATERIAL RECONCILIATION:**

Orders issued to the vendors have to be completed in all respects including Material Accounting within a maximum of **180 days** from the **date of issue of the first material** from BHEL - HPVP stores.

**Maximum of 0.5 %** on the requirement of materials (**Plates, Sections and Pipes**) is admitted towards **process allowance and invisible wastage**.

Scrap quantity is permissible up to a **maximum of 1% on Structural (Beams, Channels, Angles, Rods, Pipes etc.), 2% on Sheets, 3% for Plates** on the theoretical requirement of materials.

**If wastage and scrap is beyond the above limits**, it should be fully justified with cutting diagrams etc. which are to be approved in advance by BHEL. **Otherwise, the cost of raw materials beyond approved limits will be recovered from the contractor as per BHEL recovery rates including applicable taxes & duties.**

Material reconciliation including return of balance materials, off-cuts is to be completed within 20 days from the date of completion of the order. The material reconciliation statement shall be submitted by the contractor after verification and certification by BHEL-HPVP along with the final bill **within 30 days from the date of completion of work**. Otherwise, recovery for the balance materials shall be made from any of their pending bills without further intimation,

Repeated occurrence of inordinate delays in returning and settling the material accounting will entail BHEL the right to terminate the contract forthwith or impose a temporary suspension on further loading at the discretion of BHEL.

**12. SCRAP & OFF-CUT NORMS:**

Sl. No.	Description	Scrap Size (in mm)	Off-Cut (in MM)
1.	CS/AS Sheets & Plates	Below 500 × 250	500 × 250 & above
2.	Rolled sections Rod, angles etc. (other than -tubes, pipes)	Below 1000	1000 & above
3.	Tubes & Pipes	Below 500	500 & above
4.	Universal column	Below 1000	1000 & Above
5.	SS Sheets & Plates	Below 500 × 250	500 × 250 & above
6.	SS Structural, Rods, Tubes, Pipes	Below 250	250 & above
7.	Non – ferrous: sheets & plates, rods & tubes	Below 500 × 250 (S & PL), Below 250 (Rods & Tubes)	500 × 250 & above, 250 & above
8.	Big size Scrap	(2500 & above) × (150 to 249)	-

**13. INSPECTION:**

Party shall contact our Quality Control Dept. for stages of inspection before commencement of job and should strictly follow the stages of inspection as per QAP.

**14. WORKMANSHIP GUARANTEE:**

The vendors should give workmanship guarantee for fabricated items for a period of 18 months from the date of last delivery of the order. Any defects due to incomplete work, faulty workmanship found in the fabricated items after delivery during the defects liability period shall be rectified / replaced by the vendor free of cost. Otherwise, the expenditure incurred towards the same will be recovered from the pending bills of vendors.

**15. WORK PROGRESS:**

The fabricator shall furnish a weekly report on the progress of work along with the status of availability of free issue materials and requirement of further materials, if any.

Outsourcing dept. personnel will visit vendor's works from time to time to assess and review the work progress. Free access shall be provided to BHEL or its inspection agency at all reasonable times of the day / night.

In case the progress is not satisfactory or supplies are delayed abnormally beyond the contractual delivery date, BHEL-HPVP, Visakhapatnam reserves the right to cancel the order in part or full or get the balance job in as is where is condition completed elsewhere by another agency at the risk and cost of Fabricator. The value of the work carried out by the party will be assessed by BHEL and the same shall be final. No compensation will be given to the fabricator in case of cancellation of order or diversion of balance job even if the jobs have been processed partly.

**16. DELIVERY:**

Finished items should be handed over to BHEL-HPVP on party's delivery challans along with Job completion certificate / Final Inspection Report from inspection agency / HPVP-QC department.

**17. PENALTY:**

If delivery exceeds the stipulated delivery schedule, penalty 1/2 % of the total value of order per week or part there of subject to a maximum of 10% on the total value of the order will be levied. However, time taken for the following will not be considered as delay on the part of the Sub-Contractor.

- 1) Intermediate operations, if any, carried out by BHEL.
- 2) Waiting time for BHEL / Third party Inspection beyond a normal time of 3 days.

**18. PAYMENT TERMS:**

Payment shall be made against RA Bills within 45 days for MSE (Micro & Small Enterprise), 60 days for Medium Enterprise and 90 days for non-MSEs from the date of submission of Bill.

90% payment will be made after handing over of the finished equipments along with all inspection documents to HPVP shops / Logistics dept. / ADM site / Lova Garden site, duly inspected & cleared by Inspection authority. Balance 10% payment shall be made along with the Final Bill against completion of total order in all respects including documentation.

Vendors shall have to submit the bills in the formats specified by HPVP-Outsourcing and the bills submitted in the specified format along with necessary supporting documents are only admitted for processing. The following documents shall be submitted along with the Final Bill: -

1. No Claim Certificate from the contractor
2. No Dues Certificate from BHEL
3. Work Completion Certificate from BHEL
4. Material Reconciliation Statement submitted by the Contractor and certified by concerned authority of BHEL (if applicable)
5. Workmanship Guarantee certificate from the contractor

**19. SECRECY:**

All the documents of BHEL inclusive of Drawings, GMS and Standards made available to the fabricator should be kept in strict confidence and under no circumstance be made available to others or allow others to make use of them. Such documents shall be returned to BHEL on demand after completion of the job. This secrecy clause is binding on the employees of the fabricators also. Violation of the same may lead to suspension of business with the vendor and necessary legal action.

**20. SUB-LETTING:**

In general, sub-letting of jobs will not be permitted. But in special circumstances, this may be allowed. In such case, the party should obtain written approval from BHEL-HPVP, Visakhapatnam before sub-letting.

**21. FACTORY RULES AND REGULATIONS:**

Party shall abide by all the rules and statutory regulations in force from time to time as per factories act. It shall be party's responsibility to ensure the safety of their workmen and fulfilling the ESI, PF and other relevant statutory regulations.

**22. FACTORY RULES AND REGULATIONS:**

Party shall abide by all the rules and statutory regulations in force from time to time as per factories act. It shall be party's responsibility to ensure the safety of their workmen and fulfilling the ESI, PF and other relevant statutory regulations.

**23. SAFETY:**

- a) Contractor shall adhere to safe construction practices, guard against hazardous & unsafe working conditions and shall comply with the safety rules of BHEL and local authorities. He shall maintain First Aid facilities for all his employees and labour. Contractor's responsibility includes supply of welder kit, all safety items such as safety belts, white and colour glasses, goggles, safety helmets, safety shoes etc.
- b) *Contractor and his employees shall follow all fire & safety, security regulations of BHEL.*

**24. HOUSE KEEPING:**

During execution of work, the contractor at all times keep the working place and storage area clean and free from accumulation of waste materials, rubbish etc.,

**25. ACCIDENT / DAMAGE / CONDUCT ETC.:**

Contractor will be held responsible for any disorderly conduct / misconduct, indiscipline, theft, smoking etc., on the part of his men. He will ensure summarily eviction of such men from his premises failing which BHEL would remove them from the factory on his responsibility. Any damage to and or loss of equipment, machinery, building etc., to BHEL or BHEL employees, visitors or other contractors resulting from his own or any of his men's negligence shall be liable to be made good by him. Contractor shall be solely responsible for any accident in which you or your men or your equipment may be involved during the execution of contract on account of any reason what so ever.

**26. TERMINATION OF CONTRACT:**

In the event of any failure on the part of the contractor, BHEL reserves the right to terminate the contract by giving a notice of 2 weeks for any of the following lapses and contractual violations: -

- a) Failure to make labour payments in time as per the rules
- b) Failure to progress the job according to the agreed schedule
- c) Failure to mobilize adequate man power, tools & tackles and consumables in time
- d) Failure to adhere to Quality Standards of BHEL
- e) Refused to co-operate with other agencies working in the same area
- f) Failure to resolve labour disputes like strikes etc., within 7 days of occurrence
- g) Failure to comply with statutory regulations applicable at BHEL

BHEL shall also be free to intervene and take necessary remedial measures. All costs incurred with interest and overheads shall be recovered from contractor by such foreclosing or off-loading any part of the contract work.

**27. DISPUTES:**

Head of BHEL- HPVP Unit will be the final authority for any disputes arising out of this contract. The disputes / arbitration / settlement of contractual or legal issues shall be under the Jurisdiction of Visakhapatnam Court.

- 28.** For this procurement, Public Procurement (Preference to Make in India), Order 2017 dated 15.06.2017 & 28.05.2018 and subsequent Orders issued by the respective Nodal Ministry shall be applicable even if issued after issue of this NIT but before finalization of Contract / PO / WO against this NIT.

In the event of any Nodal Ministry prescribing higher or lower percentage of purchase preference and / or local content in respect of this procurement, same shall be applicable.

- 29.** The Bidder declares that they will not enter into any illegal or undisclosed agreement or understanding, whether formal or informal with other Bidder(s). This applies in particular to prices, specifications, certifications, subsidiary contracts, submission or non-submission of bids or any other actions to restrict competitiveness or to introduce cartelization in the bidding process.

In case, the Bidder is found having indulged in above activities, suitable action shall be taken by BHEL as per extant policies/ guidelines.

**Acceptance to Tender Terms & Conditions**

I / We hereby confirm that the Tender documents, Drawings, Quality documents etc. have been studied in detail and we have fully understood the scope of work.

I / We accept to all the Terms and Conditions of the Tender Enquiry and the prices quoted are in accordance with the same.

I / We give our acceptance to participate in Reverse Auction for this tender.

Tender documents duly signed on all the pages by the Owner / authorized representative of the bidder are attached herewith.

**Signature of the bidder with stamp**

**BUSINESS RULES FOR REVERSE AUCTION (RA)**

This has reference to tender no. **OS/22-23/7914/DST&DH/15/016, dated 24.11.2022**. BHEL shall finalise the Rates for **Fabrication of Deaerator Storage Tank, Deaerator Heater and Loose Items against S.O. 7914 inside premises of BHEL-HPVP, Visakhapatnam** through Reverse Auction mode. BHEL has made arrangement with an authorized Service provider (details will be shared before reverse auction) for conducting RA. Bidders should go through the instructions given below and submit acceptance of the same.

The technical & commercial terms are as per (a) BHEL Tender Enquiry No. **OS/22-23/7914/DST&DH/15/016, dated 24.11.2022**, (b) Bidders' technical & commercial bid (in case of two-part bid) and (c) subsequent correspondences between BHEL and the bidders, if any.

**1. Procedure of Reverse Auctioning:**

- i) Price bids of all techno-commercially qualified bidders shall be opened.
- ii) **Reverse Auction:** The 'bid decrement' will be decided by BHEL.
- iii) The lowest bidder in sealed envelope price bid shall be shown as current L1 automatically by the system and no acceptance of that price is required. System shall have the provision to indicate this bid as current L1.
- iv) Bidders by offering a minimum bid decrement or the multiples thereof can displace a standing lowest bid and become "L1" and this continues as an iterative process. However, no bidder shall be allowed to lower its bid below the current L1 by more than 5 decrements at one go.
- v) After the completion of the reverse auction, the Closing Price shall be available for further processing.
- vi) Wherever the evaluation is done on total cost basis, after Reverse Auction, prices of individual line items shall be reduced on pro-rata basis.

**2. Schedule for reverse auction:** The Reverse Auction schedule will be intimated to the techno-commercially qualified bidders at a later stage.**3. Auction extension time:** If a bidder places a bid in the last {...} minutes of closing of the Reverse Auction and if that bid gets accepted, then the auction's duration shall get extended automatically for another {...} minutes, for the entire auction (i.e. for all the items in the auction), from the time that bid comes in. Please note that the auto-extension will take place only if a bid comes in those last {...} minutes and if that bid gets accepted as the lowest bid. If the bid does not get accepted as the lowest bid, the auto-extension will not take place even if that bid might have come in the last {...} minutes. In case, there is no bid in the last {...} minutes of closing of Reverse Auction, the auction shall get closed automatically without any extension. However, bidders are advised not to wait till the last minute or last few seconds to enter their bid during the auto-extension period to avoid complications related with internet connectivity, network problems, system crash down, power failure, etc.

The above process will continue till completion of Reverse Auction.

Complaints/ Grievances, if any, regarding denial of service or any related issue should be given in writing thru e-mail/ fax to M/s. {Service provider} with a copy to BHEL within 15 minutes prior to initial closing time of Reverse Auction.

**4. Bid price:** The Bidder has to quote the {...} Price inclusive of Packing & Forwarding charges, all the routine & type tests as per tender scope, taxes, duties, freight and insurance as specified in tender document including loading (if indicated by BHEL due to deviations in technical/ commercial terms) for the Items specified. Details are as shown in Excel Sheet for calculation of total cost to BHEL (To be specified by Unit as per NIT conditions).**5. Bidding currency and unit of measurement:** Bidding will be conducted in *Indian Rupees per Unit* of the material as per the specifications mentioned in the tender.

In case of foreign currency bids, exchange rate (TT selling rate of State Bank of India) as on scheduled date of tender opening (Part-I bid) shall be considered for conversion in Indian Rupees. If the relevant day happens to be a Bank holiday, then the forex rate as on the previous bank (SBI) working day shall be taken.

6. **Validity of bids:** Price shall be valid for 90 days from the date of reverse auction. These shall not be subjected to any change whatsoever.
7. **Lowest bid of a bidder:** In case the bidder submits more than one bid, the lowest bid at the end of Reverse Auction will be considered as the bidder's final offer to execute the work.
8. Unique user IDs shall be used by bidders during bidding process. All bids made from the Login ID given to the bidders will be deemed to have been made by the bidders / bidders' company.
9. **Post auction procedure:** BHEL will proceed with the Lowest Bid in the Reverse Auction for further processing.
10. Any commercial/ technical loading shall be separately intimated to respective bidders prior to RA. The excel sheet provided in this regard shall cover all these aspects. Commercial/ technical loading if any, shall be added by the respective bidder in its price during Reverse Auction. Modalities of loading & de-loading shall be separately intimated to the bidders. The responsibility for correctness of total cost to BHEL shall lie with the bidders.
11. Reverse auction shall be conducted by BHEL (through M/s {*Service Provider*}), on pre-specified date, while the bidders shall be quoting from their own offices/ place of their choice. Internet connectivity shall have to be ensured by bidders themselves.

During the RA process if a bidder is not able to bid and requests for extension of time by FAX/ email/ phone then time extension of additional 15 minutes will be given by the service provider provided such requests come before 5 minutes of auction closing time. However, only one such request per bidder can be entertained.

In order to ward-off contingent situation of connectivity failure bidders are requested to make all the necessary arrangements/ alternatives whatever required so that they are able to circumvent such situation and still be able to participate in the reverse auction successfully. Failure of power or loss of connectivity at the premises of bidders during the Reverse auction cannot be the cause for not participating in the reverse auction. On account of this, the time for the auction cannot be extended and neither BHEL nor M/s. {*Service provider*} is responsible for such eventualities.

12. Proxy bids: Proxy bidding feature is a pro-bidder feature to safe guard the bidder's interest of any internet failure or to avoid last minute rush. The proxy feature allows bidders to place an automated bid in the system directly in an auction and bid without having to enter a new amount each time a competing bidder submits a new offer. The bid amount that a bidder enters is the minimum that the bidder is willing to offer. Here the software bids on behalf of the bidder. This obviates the need for the bidder participating in the bidding process until the proxy bid amount is decrementally reached by other bidders. When proxy bid amount is reached, the bidder (who has submitted the proxy bid) has an option to start participating in the bidding process.

The proxy amount is the minimum amount that the bidder is willing to offer. During the course of bidding, the bidder cannot delete or change the amount of a proxy bid.

Bids are submitted in decrements (decreasing bid amounts). The application automates proxy bidding by processing proxy bids automatically, according to the decrement that the auction originator originally established when creating the auction, submitting offers to the next bid decrement each time a competing bidder bids, regardless of the fact whether the competing bids are submitted as proxy or standard bids. However, it may please be noted that if a manual bid and proxy bid are submitted at the same instant manual bid will be recognized as the L1 at that instant.

In case of more than one proxy bid, the system shall bid till it crosses the threshold value of 'each lowest proxy bid' and thereafter allow the competition to decide the final L1 price.

Proxy bids are fed into the system directly by the respective bidders. As such this information is privy only to the respective bidder(s).

13. Bidders are advised to get fully trained and clear all their doubts such as refreshing of Screen, quantity being auctioned, tender value being auctioned etc. from M/s. {*Service provider*}.



14. M/s. {*Service provider*}, shall arrange to demonstrate/ train the bidder or bidder's nominated person(s), without any cost to bidders. M/s. {*Service provider*}, shall also explain the bidders, all the business rules related to the Reverse Auction. Bidders are required to submit their acceptance to the terms/ conditions/ modalities before participating in the Reverse Auction in the process compliance form as enclosed. Without this, the bidder will not be eligible to participate in the event.
15. Successful bidder shall be required to submit the final prices (L1) in prescribed format (Annexure – VI) for price breakup, quoted during the Reverse Auction, duly signed and stamped as token of acceptance without any new condition (other than those already agreed to before start of auction), after the completion of auction to M/s. {*Service provider*} besides BHEL within two working days of Auction without fail.
16. Any variation between the final bid value and that in the confirmatory signed price breakup document will be considered as tampering the tender process and will invite action by BHEL as per extant guidelines for suspension of business dealings (as available on [www.bhel.com](http://www.bhel.com)).
17. Bidders' bid will be taken as an offer to execute the work/ supplies the item as per enquiry no. **OS/22-23/7914/DST&DH/15/016, dated 24.11.2022**. Bids once made by the bidder, cannot be cancelled/ withdrawn and bidder shall be bound to execute the work as mentioned above at bidder's final bid price. Should bidder back out and not execute the contract as per the rates quoted, BHEL shall take action as per extant guidelines for suspension of business dealings (as available on [www.bhel.com](http://www.bhel.com)).
18. Bidders shall be able to view the following on their screen along with the necessary fields during Reverse Auction:
  - a. Leading (Running Lowest) Bid in the Auction (only total price of package)
  - b. Bid Placed by the bidder
  - c. Start Price
  - d. Decrement value
  - e. Rank of their own bid during bidding as well as at the close of auction.
19. BHEL's decision on award of contract shall be final and binding on all the Bidders.
20. BHEL reserves the right to extend, reschedule or cancel the Reverse Auction process at any time, before ordering, without assigning any reason, with intimation to bidders.
21. BHEL shall not have any liability to bidders for any interruption or delay in access to the site irrespective of the cause. In such cases, the decision of BHEL shall be binding on the bidders.
22. Other terms and conditions shall be as per bidder's techno-commercial offers and other correspondences, if any, till date.
23. If there is any clash between this business document and the FAQ available, if any, in the website of M/s. {*Service provider*}, the terms & conditions given in this business document will supersede the information contained in the FAQs. Any changes made by BHEL/ service provider (due to unforeseen contingencies) after the first posting shall be deemed to have been accepted if the bidder continues to access the portal after that time.
24. Bidder shall not divulge either his Bids or any other exclusive details of BHEL to any other party. If the Bidder or any of his representatives are found to be involved in Price manipulation/ cartel formation of any kind, directly or indirectly by communicating with other bidders, action *as per extant BHEL guidelines for suspension of business dealings (as available on www.bhel.com)*, shall be initiated by BHEL.

**Signature of the Bidder with Stamp**

**PROCEDURE FOR GST PAYMENT**

1. In Response to Tenders for Indigenous supplier will be entertained only if the vendor has a valid GSTIN which should be clearly mentioned in the offer. If any specific exemption is available, a declaration with due supporting documents need to be furnished for considering the offer.
2. Supplier shall mention their GSTIN in all their invoices and invoices shall be in the format as specified/prescribed under GST laws. Invoices shall necessarily contain Invoice number (in case of multiple numbering system is being followed for billing like SAP invoice no, commercial invoice no etc., then the Invoice No which is linked/uploaded in GSTN network shall be clearly indicated), item description as per PO, Quantity, Rate, Value, applicable taxes with nomenclature (like IGST, SGST, CGST & UTGST) separately, HSN/ SAC Code, etc.
3. All invoices shall bear the HSN Code for each item separately (Harmonized System of Nomenclature)/ SAC code (Services Accounting Code).
4. A declaration to the effect that all invoice particulars are/were uploaded in the GSTN network/ portal & all tax liability as per GST rules and regulations have been and will be discharged, shall be mentioned in the invoice. If not mentioned in the invoice, a separate declaration shall be submitted as per the requirement of BHEL.
5. All documents like Test Certificate, LR copy, Guarantee/Warrantee certificate, work completion certificate, any other document mentioned in PO, shall be sent along with the vehicle/consignment where ever applicable. For all consignments received within the calendar month, input credit will be availed within that month in line with monthly returns filing cycle. In case of any discrepancy in the document or non-submission of documents mentioned in the PO, then BHEL will not be able to accept or account the material, in such case availing of tax credit will be deferred to next month or so.
6. In case of discrepancy in the data uploaded by supplier in the GSTN portal or in case of any shortages or rejection in the supply, then BHEL will not be able to avail the tax credit and will notify the supplier of the same. Supplier has to rectify the data discrepancy in the GSTN portal or issue credit note (details to be uploaded in GSTN portal) for the shortages or rejections in the suppliers, within the calendar month notified by BHEL.
7. For any such delay in availing of tax credit for reasons attributable to supplier (as mentioned above), interest (calculated @ SBI Base Rate + 6%) along with penalty if any will be deducted for the delayed period i.e. from the month of receipt till the month tax credit is availed, from the running bills.
8. Under GST regime, BHEL has to discharge GST liability on LD recovered from suppliers/contractors. Hence applicable GST shall also be recoverable from suppliers/contractors on LD amount. For this Debit note will be issued by BHEL indicating the respective supply invoice number.
9. This is to inform that GST portion of invoice, shall be released only upon Vendor declaring such invoice in his GSTR-1 and receipt of goods and Tax invoice by BHEL and Confirmation of payment of GST thereon by vendor on GSTN portal. Alternatively, BG of appropriate value may be obtained from vendor which shall be valid At least one month after the confirmation of date of payment of GST by vendor on GSTN portal and receipt of Tax invoice and receipt of goods, whichever is later. Above is subject to receipt of goods/service and tax invoice thereof along with vendor declaring invoice in his return and paying GST within timeline prescribed for availing ITC by BHEL.
10. That in case vendor delays Declaring such invoice in his return and GST credit availed by BHEL is denied or reversed subsequently as per GST law, GST amount paid by BHEL towards such ITC reversal as per GST law shall be recoverable from vendor/contractor along with interest levied/ leviable on BHEL.



***Note: The above will be followed strictly for processing vendor payments to ensure GST Compliance.***

OWNER		Patratu Vidyut Utpadan Nigam Limited (PVUN Limited)	
			
MAIN SUPPLIER		BHARAT HEAVY ELECTRICALS LTD HPEP , RC PURAM HYDERABAD	
			
PROJECT 3 X 800 MW PATRATU STP EXPANSION PHASE –I			
TITLE MQP - DEAERATOR & FST CAT –I 9585-001-110-QVM-Q-871 ,REV -02			
INDEX SHEET FOR QUALITY PLAN			
SL	DESCRIPTION	DOC NO	PAGES
1	MQP FOR DEAERATOR & FST	9585-001-110-QVM-Q-871	01-06
2	QP FOR DEAERATOR TRAY ASSEMBLY	9585-001-110-QVM-Q-871A	Digitally signed by R.K.JHA Date: 2019.07.01 15:23:16 IST Reason: CAT I Location: NTPCEOC
3	QP FOR SPRAY VALVE	9585-001-110-QVM-Q-871B	
4	QP FOR DISHED END	9585-001-110-QVM-Q-871C	
CONTRACT NO: CS- 9585-001			

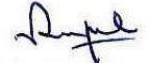

	MANUFACTURER'S NAME & ADDRESS:	MANUFACTURING QUALITY PLAN				PROJECT: 3 X 800 MW PATRATU STP EXPANSION PHASE –I PACKAGE: TG & AUX CONTRACT NO: CS- 9585-001 MAIN SUPPLIER: HPEP, BHEL HYDERABAD BHEL SALE ORDER NO: M-PA-1062-001,002 & 003 BHEL WO NO: WO: W-1-0-324-180-00,W-1-0-324-181-00,W-1-0-324-182-00,			
	BHARAT HEAVY ELECTRICALS LIMITED R.C.PURAM, HYDERABAD	ITEM: DEAERATOR & FST ( 800 MW) SUB SYSTEM: TG & AUX PKG	QP No HYQA/SSMQP/HE/510/5097 Rev. No.:02 DATE: 09.04.2019						

SL NO	COMPONENT & OPERATION	CHARACTERISTICS	CLASS	TYPE OF CHECK	QUANTUM OF CHECK		REFERENCE DOCUMENT	ACCEPTANCE NORMS	FORMAT OF RECORD		AGENCY			REMARKS
					M	C/N				D*	M	C	N	
1.	2.	3.	4.	5.	6		7	8	9.		** 10.			11.

<b>1.0</b>	<b>RAW MATERIAL &amp; BOIs</b>													
<b>1.1</b>	<b>AT SUPPLIERS WORKS</b>													
1.1.1	SHELL PLATES & PLATES FOR DISHED ENDS	A. CHEMICAL COMPOSITION	CRITICAL	CHEM.	1/ LOT	SA 516 GR.70	SA 516 GR.70	SUPPLIER'S TC	✓	P	V			
		B. MECHANICAL PROPERTIES	CRITICAL	MECH.	1/ LOT	SA 516 GR.70	SA 516 GR.70	SUPPLIER'S TC	✓	P	V			
		C. UT EXAM. AS PER DRG	CRITICAL	NDE	100%	SA 435	SA 435	SUPPLIER'S TC	✓	P	V			
		D. DIMENSIONAL EXAMINATION	MAJOR	MEASRT.	100%	PO/ SPEC	PO/ SPEC	SUPPLIER'S TC		P	V			
<b>1.2</b>	<b>AT BHEL</b>													
1.2.1	SHELL PLATES & PLATES FOR DISHED ENDS	A. VERIFICATION & CORRELATION OF MATERIAL WITH TC	MAJOR	VISUAL	100%	SA 516 GR.70	SA 516 GR.70	INSP. RECORD	✓		P	V		
		B. DIMENSIONAL CONFORMITY	MAJOR	MEASRT.	100%	PO/SPEC	PO/ SPEC	INSP. RECORD			P			
		C. SURFACE EXAMINATION	MAJOR	VISUAL	100%	PO/SPEC	PO/ SPEC	INSP. RECORD			P			
1.2.2	PIPES	A. VERIFICATION & CORRELATION OF MATERIAL WITH TC & SURFACE EXAM.	MAJOR	VISUAL	100%	SA 106 GR.B	SA 106 GR.B	INSP. RECORD	✓		P	V		
1.2.3	FLANGES	A. VERIFICATION & CORRELATION OF MATERIAL WITH TC, DIM. & SURFACE EXAM.	MAJOR	VISUAL	100%	SA105	SA105	INSP. RECORD			P			R-01
1.2.4	PLATES FOR PADS	A. VERIFICATION & CORRELATION OF MATERIAL WITH TC, DIM. & SURFACE EXAM.	MAJOR	VISUAL	100%	SA516 GR.70	SA516 GR.70	INSP. RECORD	✓		P	V		
1.2.5	TRAY ASSEMBLIES	A. VERIFICATION OF MATERIAL TC as per 9585-001-110-QVM-Q-871A	MAJOR	VISUAL	100%	QP & PO		INSP. RECORD	✓		P	V		R-02
1.2.6	SPRAY VALVES	A. VERIFICATION OF MATERIAL TC as per 9585-001-110-QVM-Q-871B	MAJOR	VISUAL	100%	QP & PO		INSP. RECORD	✓		P	V		R-01 ,R-02



		LEGEND: * RECORDS IDENTIFIED WITH (✓) SHALL BE ESSENTIALLY INCLUDED BY SUPPLIER IN QA DOCUMENTATION, M.MANUFACTURER / SUB-SUPPLIER, C-MAIN SUPPLIER. N-NTPC. INDICATE "P" PERFORM "W" WITNESS AND "V" VERIFICATION. AS APPROPRIATE "CHP" NTPC SHALL IDENTIFY IN COLUMN "N" AS "W"		DOC.NO.: 9585-001-110-QVM-Q-871 REV 02 CAT I		
MANUFACTURER / SUB-SUPPLIER	MAIN SUPPLIER					
SIGNATURE				FOR NTPC USE	REVIEWED BY	APPROVED BY

SL NO	COMPONENT & OPERATION	CHARACTERISTICS	CLASS	TYPE OF CHECK	QUANTUM OF CHECK		REFERENCE DOCUMENT	ACCEPTANCE NORMS	FORMAT OF RECORD		AGENCY			REMARKS
					M	C/N				D*	M	C	N	
1.	2.	3.	4.	5.	6		7	8	9.		** 10.			11.
<b>1.3</b>	<b>SHELL DISHED ENDS (WITH SINGLE PLATE OR BUTT WELDED PLATES)</b>													
1.3.2	AT BHEL	A. VERIFICATION OF MATERIAL TC as per 9585-001-110-QVM-Q-871C	MAJOR	VISUAL	100%		QP & PO	QP & PO	INSP. RECORD	✓		P	V	R-02
<b>2.0</b>	<b>IN PROCESS INSPECTION</b>													
2.1	SHELL FABRICATION	A. TRANSFER OF IDENTIFICATION MARKS AND CHECK FOR DIMENSIONAL MARKING	MAJOR	VISUAL	100%		TC & DRG	TC & DRG	INSP. RECORD			P		R-01
		B. SURFACE EXAM. OF PLATES AFTER ROLLING & EDGE PREPARATION	MAJOR	VISUAL	100%		ASME SEC VIII DIV.I	ASME SEC.VIII DIV.I	INSP. RECORD			P		R-01
		C. VERIFICATION OF APPROVED WPS, PQR & WQR	MAJOR	VISUAL	100%		AS PER SEC.IX	AS PER SEC.IX	-			P	V	
2.1	SHELL FABRICATION	D. FIT UP OF L & C SEAMS INCLUDING SHELL TO DISHED ENDS	MAJOR	MEASRT.	100%		DRG & ASME SEC.VIII DIV.I	DRG & ASME SEC.VIII DIV.I	INSP. RECORD			P		R-01
		E. PT AFTER BACK CHIP	MAJOR	NDE	100%		ASME SEC.V ART.6	ASME SEC.VIII APPX.8	INSP. RECORD	✓		P	V	
		F. IDENTIFICATION OF ALL WELDS (WELD NO. PUNCHED FOR CORRELATION WITH WELDER)	MAJOR	VISUAL	100%		-	-	INSP. RECORD			P		R-01
		G. RT OF WELDS	CRITICAL	NDE	100%		ASME SEC.V ART.2	ASME SEC.VIII DIV.1 UW 51	INSP. RECORD	✓		P	V	RVIEW OF RT FILM
		H. PT EXAM. OF L & C SEAMS OF THE OUTER SHELL WELDS	MAJOR	NDE	10%		ASME SEC.V ART.6	ASME SEC.VIII DIV.1 APPX.8	INSP. RECORD	✓		P	W	
		I. DIMENSIONAL CONFORMITY INCLUDING OVALITY	MAJOR	MEASRT.	10%		ASME SEC.VIII DIV.1 & DRG	ASME SEC.VIII DIV.1 & DRG	INSP. RECORD	✓		P	V	
<b>2.2</b>	<b>NOZZLE FABRICATION</b>													

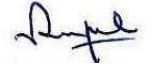

		LEGEND: * RECORDS IDENTIFIED WITH (✓) SHALL BE ESSENTIALLY INCLUDED BY SUPPLIER IN QA DOCUMENTATION, M.MANUFACTURER / SUB-SUPPLIER, C-MAIN SUPPLIER. N-NTPC. INDICATE "P" PERFORM "W" WITNESS AND "V" VERIFICATION. AS APPROPRIATE "CHP" NTPC SHALL IDENTIFY IN COLUMN "N" AS "W"		DOC.NO.: 9585-001-110-QVM-Q-871 REV 02 CAT I		
MANUFACTURER / SUB-SUPPLIER	MAIN SUPPLIER					
SIGNATURE				FOR NTPC USE	REVIEWED BY	APPROVED BY

	MANUFACTURER'S NAME & ADDRESS:	MANUFACTURING QUALITY PLAN				PROJECT: 3 X 800 MW PATRATU STP EXPANSION PHASE -I PACKAGE: TG & AUX CONTRACT NO: CS- 9585-001 MAIN SUPPLIER: HPEP, BHEL HYDERABAD BHEL SALE ORDER NO: M-PA-1062-001.002 & 003 BHEL WO NO: WO: W-1-0-324-180-00, W-1-0-324-181-00, W-1-0-324-182-00,				
	BHARAT HEAVY ELECTRICALS LIMITED R.C.PURAM, HYDERABAD	ITEM: DEAERATOR & FST ( 800 MW) SUB SYSTEM: TG & AUX PKG	QP No HYQA/SSMQP/HE/510/5097 Rev. No.:02 DATE: 09.04.2019							

SL NO	COMPONENT & OPERATION	CHARACTERISTICS	CLASS	TYPE OF CHECK	QUANTUM OF CHECK		REFERENCE DOCUMENT	ACCEPTANCE NORMS	FORMAT OF RECORD		AGENCY			REMARKS
					M	C/N				D*	M	C	N	
1.	2.	3.	4.	5.	6		7	8	9.	D*	** 10.			11.
2.2.1	NOZZLE FABRICATION WITH PLATE MATERIAL	A. TRANSFER OF IDENTIFICATION MARKS	MAJOR	VISUAL	100%		TC	TC	INSP. RECORD			P	V	
		B. FIT UP OF 'L' SEAMS	MAJOR	MEASRT.	100%		DRAWING	DRAWING	INSP. RECORD			P		R-01
		C. PT AFTER BACK CHIP	MAJOR	NDE	100%		ASME SEC.V ART .6	ASME SEC.VIII DIV.I APPX.8	INSP. RECORD	✓		P	V	
		D. RT OF THE ABOVE WELD	CRITICAL	NDE	100%		ASME SEC.V ART.2	ASME SEC.VIII DIV.I UW 51	INSP. RECORD	✓		P	V	
		E. DIMENSIONAL CONFORMITY	MAJOR	MEASRT.	100%		DRAWING	DRAWING	-	✓		P	V	
2.2.2	FABRICATION OF NOZZLES WITH SHELL	A. CHECK MARKINGS OF NOZZLE OPENINGS PRIOR TO CUTTING	MAJOR	VISUAL	100%		DRAWING	DRAWING	-			P		R-01
		B. TRANSFER OF IDENTIFICATION MARKS ON NOZZLES	MAJOR	VISUAL	100%		TC	TC	INSP. RECORD			P	V	
2.2.2	FABRICATION OF NOZZLES WITH SHELL	C. CHECK FOR DIMN. CONFORMITY OF NOZZLE WELDS; VISUAL AND DIMEN. EXAM OF WELD	MAJOR	MEASRT.	100%		DRAWING	DRAWING	INSP. RECORD			P	V	
		D. FIT UP OF FLANGE TO PIPE	MAJOR	MEASRT.	100%		DRAWING	DRAWING	INSP. RECORD			P		R-01
		E. BRANCHES TO SHELL FIT UP	MAJOR	MEASRT.	100%		DRAWING	DRAWING	INSP. RECORD			P		R-01
		F. MT EXAM OF NOZZLE TO SHELL WELDS & WELD EDGE PREPARATION	MAJOR	NDE	100%		ASME SEC.V ART.6/7	ASME SEC.VIII APPX.8/6	INSP. RECORD	✓		P	W	
2.3	SADDLE FABRICATION & INTERNAL SUPPORT & TRAY ENCLOSURES	A. FIT UP OF PADS TO SHELL	MAJOR	MEASRT.	100%		DRAWING	DRAWING	INSP. RECORD			P		R-01
		B. FIT UP OF SADDLE TO THE SHELL	MAJOR	MEASRT.	100%		DRAWING	DRAWING	INSP. RECORD			P		R-01
		C. DIM. EXAM. OF EXTERNAL SUPPORTS	MAJOR	MEASRT.	100%		DRAWING	DRAWING	INSP. RECORD			P		R-01
		D. FIT UP OF INTERNAL CONNECTION	MAJOR	MEASRT.	100%		DRAWING	DRAWING	INSP. RECORD			P		R-01

		LEGEND: * RECORDS IDENTIFIED WITH (✓) SHALL BE ESSENTIALLY INCLUDED BY SUPPLIER IN QA DOCUMENTATION, M.MANUFACTURER / SUB-SUPPLIER, C-MAIN SUPPLIER. N-NTPC. INDICATE "P" PERFORM "W" WITNESS AND "V" VERIFICATION. AS APPROPRIATE "CHP" NTPC SHALL IDENTIFY IN COLUMN "N" AS "W"		DOC.NO.: 9585-001-110-QVM-Q-871 REV 02 CAT I		
MANUFACTURER / SUB-SUPPLIER	MAIN SUPPLIER					
SIGNATURE				FOR NTPC USE	REVIEWED BY	APPROVED BY

SL NO	COMPONENT & OPERATION	CHARACTERISTICS	CLASS	TYPE OF CHECK	QUANTUM OF CHECK		REFERENCE DOCUMENT	ACCEPTANCE NORMS	FORMAT OF RECORD		AGENCY			REMARKS
					M	C/N				D*	M	C	N	
1.	2.	3.	4.	5.	6		7	8	9.		** 10.			11.
		E. CHECK FOR CLEARANCE / FIT UP OF TRAY ENCLOSURE	MAJOR	MEASRT.	100%		DRAWING	DRAWING	INSP. RECORD			P		R-01
		F. VISUAL EXAM. OF ALL WELDS	MAJOR	VISUAL	100%		ASME SEC.VIII DIV.I	ASME SEC.VIII DIV.I	INSP. RECORD			P	V	
		G. VISUAL & DIMENSIONAL EXAM OF TRAY ENCLOSURE	MAJOR	VISUAL	100%		DRAWING	DRAWING	INSP. RECORD	✓		P	V	
		H. PT EXAM OF PADS & SADDLE SUPPORT	MAJOR	NDE	100%		ASME SEC.V ART.6	ASME SEC.VIII DIV.I APPX.8	INSP. RECORD	✓		P	W	
2.4	FINAL INSPECTION	A.PWHT OF HEATER AND STORAGE TANK	MAJOR	MEASURE TIME, TEMP.	100%		ASME SEC VIII DIV.1 UCS56	ASME SEC VIII DIV.1 UCS56	HT CHART	✓		P	V	
		B. SOAP SOLUTION TEST FOR PADS	MAJOR	NDE	100%		HE-7-1022 /01	HE-7-1022 /01	INSP. RECORD	✓		P	W	R-01
		C. CHECK FOR STACKING OF STEY ASSEMBLIES AND FIXING OF SPRAY NOZZLES	MAJOR	VISUAL	100%		PROCEDURE & DRG	PROCEDURE & DRG	INSP. RECORD			P	W	R-01
2.4	FINAL INSPECTION	D. VISUAL & DIMN. CHECK OF COMPLETE TRAY ASSEMBLIES	MAJOR	MEASRT.	100%		DRAWING	DRAWING	INSP. RECORD	✓		P	W	R-01
		E. MATCHING OF FIXTURE WITH FST AND HEATER	MAJOR	VISUAL	100%		DRG. & FIXTURE	DRG. & FIXTURE	INSP. RECORD	✓		P	W	
		F. HYDRO TEST OF DEAERATOR HEADER	MAJOR	VISUAL	100%		HY0852061 REV.02 & DRG	HY0852061 REV.02 & DRG	HYDROSTATIC TEST REPORT	✓		P	W	
		G. VISUAL EXAMINATION OF ALL WELDS	MAJOR	VISUAL	100 %	10%	ASME SEC. VIII DIV 1,DRG		INSP. RECORD	✓		P	W	R-01
3.0	PRE-DESPATCH INSPECTION	A. DIMENSIONAL INSPECTION OF HEATER & STORAGE TANK	MAJOR	VISUAL	100%		DRG	DRG	AS BUILT DRG.	✓		P	V	
		B. MATCH MARKING OF STORAGE TANK SECTIONS FOR SITE ASSLY.	MAJOR	VISUAL & MEASRT.	-		DRAWING & PROCEDURE	DRAWING & PROCEDURE	INSP. RECORD	✓		P	W	R-01

		LEGEND: * RECORDS IDENTIFIED WITH (✓) SHALL BE ESSENTIALLY INCLUDED BY SUPPLIER IN QA DOCUMENTATION, M.MANUFACTURER / SUB-SUPPLIER, C-MAIN SUPPLIER. N-NTPC. INDICATE "P" PERFORM "W" WITNESS AND "V" VERIFICATION. AS APPROPRIATE "CHP" NTPC SHALL IDENTIFY IN COLUMN "N" AS "W"		DOC.NO.: 9585-001-110-QVM-Q-871 REV 02 CAT I			
MANUFACTURER / SUB-SUPPLIER				MAIN SUPPLIER			
SIGNATURE					FOR NTPC USE	REVIEWED BY	APPROVED BY

SL NO	COMPONENT & OPERATION	CHARACTERISTICS	CLASS	TYPE OF CHECK	QUANTUM OF CHECK		REFERENCE DOCUMENT	ACCEPTANCE NORMS	FORMAT OF RECORD		AGENCY			REMARKS
					M	C/N				D*	M	C	N	
1.	2.	3.	4.	5.	6		7	8	9.		** 10.			11.
		C. CHECK FOR COMPLETENESS, VERIFICATION OF TEST / INSPECTION RECORDS	CRITICAL	VISUAL	100%		QP, TECH. SPEC. DRG & DATA SHEET	QP, TECH. SPEC. DRG & DATA SHEET	MANUFACTURER TC			P	V	
		D. CLEANLINESS AFTER SAND/ SHOT BLASTING OF INTERNAL/ EXTERNAL SURFACES OF FST & EXTERNAL SURFACE OF HEATER	MAJOR	VISUAL	100%		HE-7-1023 /01	HE-7-1023 /01	INSP. RECORD			P		
		E. CLEANING, PAINTING & PACKING FOR DISPATCH INCLUDING BLANKING OF ALL OPENINGS	MAJOR	VISUAL	100%		HE-7-1023 /01	HE-7-1023 /01	INSP. RECORD	✓		P	V	R-01
		F. PRESERVATION OF WELD EDGE PREPARATION	MAJOR	VISUAL	100%		HE-7-1023 /01	HE-7-1023 /01	INSP. RECORD	✓		P	V	R-01
		G. IDENTIFICATION MARKINGS ON ASSEMBLIES & LOOSE ITEMS PRIOR TO TRANSPORT	MAJOR	VISUAL	100%		DRG./ QP / SPEC.	DRG ./QP / SPEC.	-			P		

**NOTES:**



- MATERIALS SHALL BE TESTED AT SUPPLIERS' WORKS AS PER SPECIFICATION AND REQUIREMENTS AS INDICATED IN THE QUALITY PLAN AND SHALL BE AS INDICATED IN THE DRAWING / DATA SHEET.

**NOTES FOR FIXING TRAY ASSEMBLIES & SPRAY VALVES:**

- CLOSING DISHED END SHALL BE ASSEMBLED ONLY AFTER ASSEMBLY OF SPRAY VALVES AND TRAY ASSEMBLIES.
- SPRAY VALVES ARE TO BE ASSEMBLED PRIOR TO ASSEMBLY OF TRAYS.
- QC TO ENSURE WELDING OF STOPPERS FOR HOLD DOWN RODS AND ASSEMBLY OF HOLD DOWN ANGLES WITH CLEATS.
- QC TO ENSURE TACK WELDING OF DOUBLE LOCK NUTS FOR SPRAY VALVE FIXING TO VALVE PLATE.
- QC TO ENSURE AVAILABILITY OF SPLIT PIN THROUGH THE TOP LOCK NUT AND STEM OF THE SPRAY VALVE BEFORE ASSEMBLY OF SPRAY VALVE.
- QC TO ENSURE POSITIONING OF SPLIT PIN AT THE BOTTOM OF HOLD DOWN ROD DURING TRAY ASSEMBLY.

**IBR REQUIREMENTS:**

- AS A STATUTORY REQUIREMENT, DESIGN, CONSTRUCTION AND TESTING SHALL BE AS PER IBR CODE REQUIREMENTS.
- ALL RELAVANT IBR CERTIFIED TC SHALL BE FURNISHED ALONG WITH OTHER QC DOCUMENTATION AS PER QUALITY PLAN.

		LEGEND: * RECORDS IDENTIFIED WITH (✓) SHALL BE ESSENTIALLY INCLUDED BY SUPPLIER IN QA DOCUMENTATION, M.MANUFACTURER / SUB-SUPPLIER, C-MAIN SUPPLIER. N-NTPC. INDICATE "P" PERFORM "W" WITNESS AND "V" VERIFICATION. AS APPROPRIATE "CHP" NTPC SHALL IDENTIFY IN COLUMN "N" AS "W"		DOC.NO.: 9585-001-110-QVM-Q-871 REV 02 CAT I		
MANUFACTURER / SUB-SUPPLIER	MAIN SUPPLIER					
SIGNATURE				FOR NTPC USE	REVIEWED BY	APPROVED BY



	MANUFACTURER'S NAME & ADDRESS:		MANUFACTURING QUALITY PLAN				PROJECT: 3 X 800 MW PATRATU STP EXPANSION PHASE –I PACKAGE: TG & AUX CONTRACT NO: CS- 9585-001 MAIN SUPPLIER: HPEP, BHEL HYDERABAD BHEL SALE ORDER NO: M-PA-1062-001,002 & 003 BHEL WO NO: WO: W-1-0-324-180-00,W-1-0-324-181-00,W-1-0-324-182-00,							
	BHARAT HEAVY ELECTRICALS LIMITED R.C.PURAM, HYDERABAD		ITEM: DEAERATOR & FST ( 800 MW) SUB SYSTEM: TG & AUX PKG		QP No HYQA/SSMQP/HE/510/5097 Rev. No.:02 DATE: 09.04.2019									
SL NO	COMPONENT & OPERATION	CHARACTERISTICS	CLASS	TYPE OF CHECK	QUANTUM OF CHECK		REFERENCE DOCUMENT	ACCEPTANCE NORMS	FORMAT OF RECORD		AGENCY			REMARKS
					M	C/N				D*	M	C	N	
1.	2.	3.	4.	5.	6		7	8	9.	D*	** 10.			11.

**GENERAL LEGENDS**

NDE	NON DESTRUCTIVE EXAMINATION	ASSLY	ASSEMBLY	CHEM	CHEMICAL
UT	ULTRASONIC TEST	QC	QUALITY CONTROL	MECH	MECHANICAL
PT	DYE PENETRANT TEST	TPIA	THIRD PARTY INSPECTION AGENCY	TC	TEST CERTIFICATES
MT/MPI	MAGENTIC PARTICLE INSPECTION	WPS	WELDING PROCEDURE SPECIFICATION	VERFN	VERIFICATION
RT	RADIOGRAPHY TEST	WQR	WELDER QUALIFICATION RECORD	IGC	INTER GRANULAR CORROSSION
MEASRT	MEASUREMENT	PQR	PROCEDURE QUALIFICATION RECORD	HT	HEAT TREATMENT
DIMN	DIMENSION	IR	INSPECTION REPORT	QA	QUALITY ASSURANCE

**REVISION HISTORY**

SL NO.	REVISION DETAILS	DATE OF REV	PREPARED BY	REVIEWED BY	APPROVED BY
1	FIRST ISSUE	02.07.2018	AB	DSS	DSS
2	FIRST REVISION	02.08.2018	AB	DSS	DSS
3	SECOND REVISION	09.04.2019	AB	DSS	DSS

		LEGEND: * RECORDS INDENTIFIED WITH (✓) SHALL BE ESSENTIALLY INCLUDED BY SUPPLIER IN QA DOCUMENTATION, M.MANUFACTURER / SUB-SUPPLIER, C-MAIN SUPPLIER. N-NTPC. INDICATE "P" PERFORM "W" WITNESS AND "V" VERIFICATION. AS APPROPRIATE "CHP" NTPC SHALL IDENTIFY IN COLUMN "N" AS "W"		DOC.NO.: 9585-001-110-QVM-Q-871 REV 02 CAT I		
MANUFACTURER / SUB-SUPPLIER	MAIN SUPPLIER					
SIGNATURE				FOR NTPC USE	REVIEWED BY	APPROVED BY

	MANUFACTURER'S NAME & ADDRESS: <b>BHARAT HEAVY ELECTRICALS LTD. HYDERABAD</b>		MANUFACTURING QUALITY PLAN				PROJECT: 3 X 800 MW PATRATU STP EXPANSION PHASE -I PACKAGE: TG & AUX CONTRACT NO: CS- 9585-001 MAIN SUPPLIER: HPEP, BHEL HYDERABAD BHEL SALE ORDER NO: M-PA-1062-001,002 & 003							
	ITEM : <b>DEAERATOR TRAY ASSEMBLY</b> BHEL SPEC : <b>HE51272-R05</b>		QP No : 9585-001-110-QVM-Q-871 A Rev. No.:00 DATE: 09.04.2019											
SL NO	COMPONENT & OPERATION	CHARACTERISTICS	CLASS	TYPE OF CHECK	QUANTUM OF CHECK		REFERENCE DOCUMENT	ACCEPTANCE NORMS	FORMAT OF RECORD		AGENCY			REMARKS
					M	C/N			M	C	N			
1.	2.	3.	4.	5.	6		7	8	9.	D*	** 10.			11.

**1.0 RAW MATERIAL & BOUGHT OUT ITEMS**



1.1	SIDE PLATE	CHEM. COMPOSITION	MAJOR	CHEM.	SAMPLE/HEAT	SA 240 TP 430	SUPPLIERS TC	✓	V	V	V	
		MECH. PROPERTIES	MAJOR	MECH.	SAMPLE/HEAT	SA 240 TP 430	SUPPLIERS TC	✓	V	V	V	
1.2	COLLECTING PLATES	CHEM. COMPOSITION	MAJOR	CHEM.	SAMPLE/HEAT	SA 240 TP 430	SUPPLIERS TC	✓	V	V	V	
		MECH. PROPERTIES	MAJOR	MECH.	SAMPLE/HEAT	SA 240 TP 430	SUPPLIERS TC	✓	V	V	V	
1.3	RIVETS	CHEM. COMPOSITION	MAJOR	CHEM.	SAMPLE/HEAT	SA 479 TP 304	SUPPLIERS TC	✓	V	V	V	
		SURFACE FINISH	MAJOR	VISUAL	100%	SA 479 TP 304	SA 479 TP 304	IR		P		

**2.0 IN PROCESS INSPECTION**

2.1	SIDE PLATES	SLITTING , HOLES, PUNCHING & BENDING	MAJOR	MEASURT ,VISUAL	100%	BHEL DRG.	BHEL DRG.	IR		P	V	
2.2	COLLECTING PLATES	BLANKING , HOLES, PUNCHING & BENDING	MAJOR	MEASURT ,VISUAL	100%	BHEL DRG.	BHEL DRG.	IR		P	V	
2.3	BUFFING ( IF REQUIRED)	SIDE, COLLECTING PLATE	MAJOR	VISUAL	AS REQUIRED	MFR STD	SMOOTH FINISH	IR		P	V	

**3.0 FINAL ASSEMBLY & TESTING**

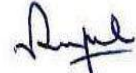
3.1	SIDE PLATE TO COLLECTING PLATE ASSLY	VISULA & DIMENSIONAL INSPECTION	MAJOR	VISUAL, MEASRT	100%	BHEL DRG	BHEL DRG	IR.	✓	P	W	W	10 % RANDOM BY BHEL 5% BY NTPC
3.2		STRAIGHHTNESS AND SQUARE NESS	MAJOR	VISUAL, MEASRT	100%	BHEL DRG	BHEL DRG	IR.	✓	P	W	W	
3.3		TRIAL ASSLY OF 10 TRAYS AT RANDOM ( IN STACKED CONDITION)	MAJOR	VISUAL, MEASRT	100%	BHEL DRG	BHEL DRG	IR.	✓	P	W	W	

 ALOK BEHERA SR.ENGR/QA	 DS SATPUTE AGM/QA	LEGEND: * RECORDS INDENTIFIED WITH (✓) SHALL BE ESSENTIALLY INCLUDED BY SUPPLIER IN QA DOCUMENTATION, M.MANUFACTURER / SUB-SUPPLIER, C-MAIN SUPPLIER/MAIN SUPPLIER TPIA. N-NTPC. INDICATE "P" PERFORM "W" WITNESS AND "V" VERIFICATION. AS APPROPRIATE "CHP" NTPC SHALL IDENTIFY IN COLUMN "N" AS "W"		DOC.NO 9585-001-110-QVM-Q-871 A REV 00 CAT I/III			
MAIN SUPPLIER				FOR NTPC USE	REVIEWED BY	APPROVED BY	APPROVAL SEAL
SIGNATURE							

	MANUFACTURER'S NAME & ADDRESS: <b>BHARAT HEAVY ELECTRICALS LTD. HYDERABAD</b>	MANUFACTURING QUALITY PLAN				PROJECT: 3 X 800 MW PATRATU STP EXPANSION PHASE -I PACKAGE: TG & AUX CONTRACT NO: CS- 9585-001 MAIN SUPPLIER: HPEP, BHEL HYDERABAD BHEL SALE ORDER NO: M-PA-1062-001,002 & 003			
		ITEM : <b>DEAERATOR TRAY ASSEMBLY</b> BHEL SPEC : <b>HE51272-R05</b>		QP No : 9585-001-110-QVM-Q-871 A Rev. No.:00 DATE: 09.04.2019					

SL NO	COMPONENT & OPERATION	CHARACTERISTICS	CLASS	TYPE OF CHECK	QUANTUM OF CHECK		REFERENCE DOCUMENT	ACCEPTANCE NORMS	FORMAT OF RECORD		AGENCY			REMARKS
					M	C/N				D*	M	C	N	
1.	2.	3.	4.	5.	6		7	8	9.	D*	** 10.			11.



4.0	PRE DESPATCH INSPECTION													
4.1	TRAY ASSEMBLY	PRE DISPATCH CHECKS 1. CLEANLINESS 2. COMPLETENESS 3. IDENTIFICATION/ MARKING	CRITICAL	VISUAL	100%		BHEL SPEC / DRAWING	BHEL SPEC / DRAWING	INSPECTION RECORD			P	V	

## NOTES:

- 1) MATERIAL OF CONSUTRCTION SHALL BE AS PER BHEL GA DRAWING /SPEC.
- 2) IN CASE OF DIFFERING/CONFLICTING REQUIREMENTS, ANOMALIES, ANY DRAWING/SPECN SHALL PREVAIL OVER QUALITY PLAN
- 3) THIS QP IS APPLICABLE ONLY FOR NTPC APPROVED VENDORS AS PER LOA APPROVED VENDOR LIST FOR PATRATU
- 4) THIS QP IS APPLICABLE FOR THE MAIN AS WELL AS SUBSEQUENT SPARE SUPPLIES.
- 5) THIS QP IS APPLICABLE ONLY FOR NTPC APPROVED VENDORS AS PER LOA APPROVED VENDOR LIST OF PATRATU FOR CAT -I AND CAT -II CATEGORISED VENDOR.
- 6) FOR IMPORTED VENDORS, BHEL & NTPC WITNESS SHALL BE CONSIDERED VERIFICATION
- 4) RAW MATERIAL i.e. SHEETS SHALL BE FROM JINDAL STAINLESS LITD, HISAR MAKE and OTHER NTPC APPROVED MAKE FOR SUPPLY BY INDIGENOUS VENDOR.
- 5) PACKING & MARKING AS PER BHEL SPEC .ALL REQUIREMENTS AS PER BHEL SPEC /DRAWING ARE TO BE COMPLIED WITH.
- 6) ALL MANUFACTURING SHALL BE CARRIED OUT AS PER BHEL'S DRAWING, DESIGN AND ESTABLISHED MANUFACTURING PROCEDURE.

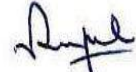

## GENERAL LEGENDS

NDE	NON DESTRUCTIVE EXAMINATION	ASSLY	ASSEMBLY	CHEM	CHEMICAL
UT	ULTRASONIC TEST	QC	QUALITY CONTROL	MECH	MECHANICAL
PT	DYE PENETRANT TEST	TPIA	THIRD PARTY INSPECTION AGENCY	TC	TEST CERTIFICATES
MT/MPI	MAGENTIC PARTICLE INSPECTION	WPS	WELDING PROCEDURE SPECIFICATION	VERFN	VERIFICATION
RT	RADIOGRAPHY TEST	WQR	WELDER QUALIFICATION RECORD	IGC	INTER GRANULAR CORROSSION
MEASRT	MEASUREMENT	PQR	PROCEDURE QUALIFICATION RECORD	HT	HEAT TREATMENT
DIMN	DIMENSION	IR	INSPECTION REPORT	QA	QUALITY ASSURANCE
COC	CERTIFICATE OF COMPLIANCE	DRG /DS	DRAWING /DATA SHEET	PO	PURCHASE ORDER

 ALOK BEHERA SR.ENGR/QA	 DS SATPUTE AGM/QA	LEGEND: * RECORDS INDENTIFIED WITH (✓) SHALL BE ESSENTIALLY INCLUDED BY SUPPLIER IN QA DOCUMENTATION, M.MANUFACTURER / SUB-SUPPLIER, C-MAIN SUPPLIER/MAIN SUPPLIER TPIA. N-NTPC. INDICATE "P" PERFORM "W" WITNESS AND "V" VERIFICATION. AS APPROPRIATE "CHP" NTPC SHALL IDENTIFY IN COLUMN "N" AS "W"		DOC.NO 9585-001-110-QVM-Q-871 A REV 00 CAT I/III		
				FOR NTPC USE	REVIEWED BY	APPROVED BY
MAIN SUPPLIER						
SIGNATURE						

		MANUFACTURER'S NAME & ADDRESS: <b>BHARAT HEAVY ELECTRICALS LTD. HYDERABAD</b>		<b>MANUFACTURING QUALITY PLAN</b>				PROJECT: 3 X 800 MW PATRATU STP EXPANSION PHASE -I PACKAGE: TG & AUX CONTRACT NO: CS- 9585-001 MAIN SUPPLIER: HPEP, BHEL HYDERABAD BHEL SALE ORDER NO: M-PA-1062-001,002 & 003						
		ITEM : <b>DEAERATOR TRAY ASSEMBLY</b> <b>BHEL SPEC : HE51272-R05</b>		QP No : 9585-001-110-QVM-Q-871 A Rev. No.:00 DATE: 09.04.2019										
SL NO	COMPONENT & OPERATION	CHARACTERISTICS	CLASS	TYPE OF CHECK	QUANTUM OF CHECK		REFERENCE DOCUMENT	ACCEPTANCE NORMS	FORMAT OF RECORD		AGENCY			REMARKS
					M	C/N						M	C	
1.	2.	3.	4.	5.	6		7	8	9.	D*	** 10.			11.

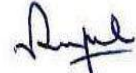

APPROVED SUB VENDORS OF PATRATU ALONG WITH APPROVAL CONDITION AS MENTION IN LOA.	
1. NEW TERRA -USA	NEWTERRA, INC. 2248 MERIDIAN BLVD., SUITE H, MINDEN, NEVADA 89423-MINDEN, NEVADA, USA
2. STERLING - USA	STERLING DEAERATOR COMPANY 4215 NE PORT DRIVE, LEE'S SUMMIT, MO 64064, 11111-USA
3. VRK INDUSTRIES – HYDERABAD	VRK INDUSTRIES D-60, PHASE-IV EXTN, IDA, JEEDIMETLA HYDERABAD, 500055

 ALOK BEHERA SR.ENGR/QA	 DS SATPUTE AGM/QA	LEGEND: * RECORDS IDENTIFIED WITH (✓) SHALL BE ESSENTIALLY INCLUDED BY SUPPLIER IN QA DOCUMENTATION, M.MANUFACTURER / SUB-SUPPLIER, C-MAIN SUPPLIER/MAIN SUPPLIER TPIA. N-NTPC. INDICATE "P" PERFORM "W" WITNESS AND "V" VERIFICATION. AS APPROPRIATE "CHP" NTPC SHALL IDENTIFY IN COLUMN "N" AS "W"		DOC.NO 9585-001-110-QVM-Q-871 A REV 00 CAT I/III		
				MAIN SUPPLIER	FOR NTPC USE	REVIEWED BY
SIGNATURE						

	MANUFACTURER'S NAME & ADDRESS: <b>BHARAT HEAVY ELECTRICALS LTD. HYDERABAD</b>	MANUFACTURING QUALITY PLAN					PROJECT: 3 X 800 MW PATRATU STP EXPANSION PHASE -I PACKAGE: TG & AUX CONTRACT NO: CS- 9585-001 MAIN SUPPLIER: HPEP, BHEL HYDERABAD BHEL SALE ORDER NO: M-PA-1062-001,002 & 003					
		ITEM: <b>DEAERATOR SPRAY VALVE</b> BHEL SPEC : <b>HE51272-R05</b>	QP No : 9585-001-110-QVM-Q-871B Rev. No.:00 DATE: 09.04.2019									

SL NO	COMPONENT & OPERATION	CHARACTERISTICS	CLASS	TYPE OF CHECK	QUANTUM OF CHECK		REFERENCE DOCUMENT	ACCEPTANCE NORMS	FORMAT OF RECORD		AGENCY			REMARKS
					M	C/N			M	C	N			
1.	2.	3.	4.	5.	6.		7.	8.	9.	D*	** 10.			11.



2.0 INPROCESS INSPECTION														
<b>2.0 RAW MATERIALS &amp; BOUGHT OUT ITEMS</b>														
1.1	SPRAY VALVES BODY & STEM (AT SUPPLIERS WORKS)	A)-CHEMICAL COMPOSITION	MAJOR	CHEMICAL	AS PER SPEC		BHEL DRAWING	BHEL DRAWING	SUPPLIERS TC	✓	V	V	V	
		B)-MECHANICAL PROPERTIES	MAJOR	MECHANICAL	AS PER SPEC		BHEL DRAWING	BHEL DRAWING	SUPPLIERS TC	✓	V	V	V	
1.2	SPRING	A)-CHEMICAL COMPOSITION	MAJOR	CHEMICAL	AS PER SPEC		BHEL DRAWING	BHEL DRAWING	SUPPLIERS TC	✓	V	V	V	
		B)-MECHANICAL PROPERTIES	MAJOR	MECHANICAL	AS PER SPEC		BHEL DRAWING	BHEL DRAWING	SUPPLIERS TC	✓	V	V	V	
1.3	RETAINER	A)-CHEMICAL COMPOSITION	MAJOR	CHEMICAL	AS PER SPEC		BHEL DRAWING	BHEL DRAWING	SUPPLIERS TC/COC	✓	V	V	V	
		B)-MECHANICAL PROPERTIES	MAJOR	MECHANICAL	AS PER SPEC		BHEL DRAWING	BHEL DRAWING		✓	V	V	V	
1.4	NUT	A)-CHEMICAL COMPOSITION	MAJOR	CHEMICAL	AS PER SPEC		BHEL DRAWING	BHEL DRAWING	SUPPLIERS TC/COC	✓	V	V	V	
		B)-MECHANICAL PROPERTIES	MAJOR	MECHANICAL	AS PER SPEC		BHEL DRAWING	BHEL DRAWING		✓	V	V	V	
1.5	SPLIT COTTER PIN	A)-CHEMICAL COMPOSITION	MAJOR	CHEMICAL	AS PER SPEC		BHEL DRAWING	BHEL DRAWING	SUPPLIERS TC/COC	✓	V	V	V	
<b>2.0 INPROCESS INSPECTION</b>														
2.1	SPRAY VALVES BODY & STEM (AT SUPPLIERS WORKS)	A) CO-RELATION OF TCS AND MATERIAL IDENTIFICATION	MAJOR	VISUAL	100%		BHEL DRAWING	BHEL DRAWING	IR	✓	P	V		
		B)-HEAT TREATMENT	MAJOR	VISUAL	100%		AS PER MATERIAL SPEC. IN BHEL DRAWING	AS PER MATERIAL SPEC. IN BHEL DRAWING	SUPPLIERS TC	✓	P	V	V	
		C)-SURFACE FINISH	MAJOR	VISUAL	100%		AS PER MATERIAL SPEC. IN BHEL DRAWING	AS PER MATERIAL SPEC. IN BHEL DRAWING	SUPPLIERS TC		P			
		D)-DYE PENETRATION EXAMINATION	MAJOR	NDE	100 %	10%	AS PER MATERIAL SPEC. IN BHEL DRAWING	AS PER MATERIAL SPEC. IN BHEL DRAWING	SUPPLIERS TC	✓	P	W	V	

 ALOK BEHERA SR.ENGR/QA	 DS SATPUTE AGM/QA	LEGEND: * RECORDS IDENTIFIED WITH (✓) SHALL BE ESSENTIALLY INCLUDED BY SUPPLIER IN QA DOCUMENTATION, M.MANUFACTURER / SUB-SUPPLIER, C-MAIN SUPPLIER/MAIN SUPPLIER TPIA. N-NTPC. INDICATE "P" PERFORM "W" WITNESS AND "V" VERIFICATION. AS APPROPRIATE "CHP" NTPC SHALL IDENTIFY IN COLUMN "N" AS "W"		DOC.NO 9585-001-110-QVM-Q-871B REV 00 CAT I/III		
				FOR NTPC USE	REVIEWED BY	APPROVED BY
MAIN SUPPLIER						
SIGNATURE						

SL NO	COMPONENT & OPERATION	CHARACTERISTICS	CLASS	TYPE OF CHECK	QUANTUM OF CHECK		REFERENCE DOCUMENT	ACCEPTANCE NORMS	FORMAT OF RECORD		AGENCY			REMARKS
					M	C/N			D*	M	C	N		
1.	2.	3.	4.	5.	6.		7.	8.	9.	D*	** 10.			11.
2.2	SPRING	A)-LOAD TEST	MAJOR	STIFFNESS	100%		AS PER MATERIAL SPEC. & BHEL DRAWING	AS PER MATERIAL SPEC & BHEL DRAWING	SUPPLIERS TC	✓	P	W	V	
<b>3.0 FINAL INSPECTION &amp; TESTING</b>														
3.1	SPRAY VALVE ASSEMBLY	VISUAL & DIMENSIONAL	MAJOR	VISUAL MEASRT			BHEL DRAWING	HE51272 REV.04 & BHEL DRAWING	SUPPLIERS TC	✓	P	W	W	10 % BY NTPC
3.2	SPRAY VALVE ASSEMBLY	PERFORMANCE TEST	MAJOR	FLOW VS PRESSURE DROP CHARACTERISTICS	100 %	10%	BHEL DRAWING	HE51272 REV.04 & BHEL DRAWING	SUPPLIERS TC	✓	P	W	W	10 % BY NTPC
<b>4.0 PAINTING, PRESERVATION, MARKING &amp; PACKING</b>														
4.1	MARKING	IDENTIFICATION	MAJOR	VISUAL	100%		HE51272 REV.04	HE51272 REV.04	SUPPLIERS TC	✓	P	V		
4.2	PRESERVATION AND PACKING	PRESERVATION, PACKING	MAJOR	VISUAL	100%		HE51272 REV.04	HE51272 REV.04	SUPPLIERS TC	✓	P	V		

**Notes:**

- ALL REQUIREMENTS AS PER BHEL SPECIFICATION, DRAWING & PO ARE TO BE COMPLIED WITH.
- VENDOR HAS TO REFER TO PROJECT SPECIFIC BHEL MANUFACTURING QUALITY PLAN FOR STAGES OF INSPECTION BY CUSTOMER OF BHEL, IF ANY.
- REPLACEMENT/ REPAIR/ CORRECTION SHALL BE CARRIED OUT IN CASE ANY MAJOR NON-CONFORMANCE WITH PRIOR APPROVAL FROM BHEL.
- MATERIAL OF CONSTRUCTION SHALL BE AS PER BHEL DRAWING
- IN CASE OF DIFFERING/CONFLICTING REQUIREMENTS, ANOMALIES, ANY DRAWING/SPECN SHALL PREVAIL OVER QUALITY PLAN
- THIS QP IS APPLICABLE ONLY FOR NTPC APPROVED VENDORS AS PER LOA APPROVED VENDOR LIST OF PATRATU FOR CAT –I AND CAT –II CATEGORISED VENDOR.
- THIS QP IS APPLICABLE FOR THE MAIN AS WELL AS SUBSEQUENT SPARE SUPPLIES.
- FOR IMPORTED VENDORS, BHEL & NTPC WITNESS SHALL BE CONSIDERED VERIFICATION



 ALOK BEHERA SR.ENGR/QA	 DS SATPUTE AGM /QA	LEGEND: * RECORDS IDENTIFIED WITH (✓) SHALL BE ESSENTIALLY INCLUDED BY SUPPLIER IN QA DOCUMENTATION, M.MANUFACTURER / SUB-SUPPLIER, C-MAIN SUPPLIER/MAIN SUPPLIER TPIA. N-NTPC. INDICATE "P" PERFORM "W" WITNESS AND "V" VERIFICATION. AS APPROPRIATE "CHP" NTPC SHALL IDENTIFY IN COLUMN "N" AS "W"		DOC.NO 9585-001-110-QVM-Q-871B REV 00 CAT I/III		
				FOR NTPC USE	REVIEWED BY	APPROVED BY
MAIN SUPPLIER						
SIGNATURE						

	MANUFACTURER'S NAME & ADDRESS: <b>BHARAT HEAVY ELECTRICALS LTD. HYDERABAD</b>		MANUFACTURING QUALITY PLAN				PROJECT: 3 X 800 MW PATRATU STP EXPANSION PHASE -I PACKAGE: TG & AUX CONTRACT NO: CS- 9585-001 MAIN SUPPLIER: HPEP, BHEL HYDERABAD BHEL SALE ORDER NO: M-PA-1062-001,002 & 003							
	ITEM: <b>DEAERATOR SPRAY VALVE</b> BHEL SPEC : <b>HE51272-R05</b>		QP No : 9585-001-110-QVM-Q-871B Rev. No.:00 DATE: 09.04.2019											
SL NO	COMPONENT & OPERATION	CHARACTERISTICS	CLASS	TYPE OF CHECK	QUANTUM OF CHECK		REFERENCE DOCUMENT	ACCEPTANCE NORMS	FORMAT OF RECORD		AGENCY			REMARKS
					M	C/N				D*	M	C	N	
1.	2.	3.	4.	5.	6	7	8	9.	D*	** 10.	11.			

GENERAL LEGENDS						
NDE	NON DESTRUCTIVE EXAMINATION	ASSLY	ASSEMBLY		CHEM	CHEMICAL
UT	ULTRASONIC TEST	QC	QUALITY CONTROL		MECH	MECHANICAL
PT	DYE PENETRANT TEST	TPIA	THIRD PARTY INSPECTION AGENCY		TC	TEST CERTIFICATES
MT/MPI	MAGENTIC PARTICLE INSPECTION	WPS	WELDING PROCEDURE SPECIFICATION		VERFN	VERIFICATION
RT	RADIOGRAPHY TEST	WQR	WELDER QUALIFICATION RECORD		IGC	INTER GRANULAR CORROSSION
MEASRT	MEASUREMENT	PQR	PROCEDURE QUALIFICATION RECORD		HT	HEAT TREATMENT
DIMN	DIMENSION	IR	INSPECTION REPORT		QA	QUALITY ASSURANCE
COC	CERTIFICATE OF COMPLIANCE	DRG /DS	DRAWING /DATA SHEET		PO	PURCHASE ORDER

### APPROVED SUB VENDORS OF PATRATU ALONG WITH APPROVAL CONDITION AS MENTION IN LOA

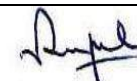

1. NEW terra - USA	NEWTERRA, INC. 2248 MERIDIAN BLVD., SUITE H, MINDEN, NEVADA 89423-MINDEN, NEVADA, USA Email: jstrogus@newterra.com
2. STERLING - USA	STERLING DEAERATOR COMPANY 4215 NE PORT DRIVE, LEE'S SUMMIT, MO 64064, 11111-USA Email: scottross@sterlingdeaerator.com

 ALOK BEHERA SR.ENGR/QA	 DS SATPUTE AGM /QA	LEGEND: * RECORDS IDENTIFIED WITH (✓) SHALL BE ESSENTIALLY INCLUDED BY SUPPLIER IN QA DOCUMENTATION, M.MANUFACTURER / SUB-SUPPLIER, C-MAIN SUPPLIER/MAIN SUPPLIER TPIA. N-NTPC. INDICATE "P" PERFORM "W" WITNESS AND "V" VERIFICATION. AS APPROPRIATE "CHP" NTPC SHALL IDENTIFY IN COLUMN "N" AS "W"		DOC.NO 9585-001-110-QVM-Q-871B REV 00 CAT I/III		
MAIN SUPPLIER				FOR NTPC USE	REVIEWED BY	APPROVED BY
SIGNATURE						

	MANUFACTURER'S NAME & ADDRESS: <b>BHARAT HEAVY ELECTRICALS LTD. HYDERABAD</b>	MANUFACTURING QUALITY PLAN				PROJECT: 3 X 800 MW PATRATU STP EXPANSION PHASE -I PACKAGE: TG & AUX CONTRACT NO: CS- 9585-001 MAIN SUPPLIER: HPEP, BHEL HYDERABAD BHEL SALE ORDER NO: M-PA-1062-001,002 & 003				
		ITEM: <b>DISHED END ( CS &amp; AS )</b> <b>HE 51370 REV 00</b> <b>HE 51527 REV 00</b>		QP No : 9585-001-110-QVM-Q-871C Rev. No.:00 DATE: 09.04.2019						

SL NO	COMPONENT & OPERATION	CHARACTERISTICS	CLASS	TYPE OF CHECK	QUANTUM OF CHECK		REFERENCE DOCUMENT	ACCEPTANCE NORMS	FORMAT OF RECORD		AGENCY			REMARKS
					M	C/N				D*	M	C	N	
1.	2.	3.	4.	5.	6.		7.	8.	9.		** 10.			11.

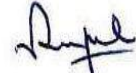

1	PLATE MATERIAL	VERIFICATION OF MILL TEST CERTIFICATE AND IDENTIFICATION MARKS FOR MECHANICAL AND CHEMICAL PROPERTIES	MAJOR	VISUAL	100%		SA 387 GR.12 CLASS 2 ( with S1, S3, S5 and S8 ) / SA 516 GR 70 (with S1,S5,S8 )	SA 387 GR.12 CLASS 2 ( with S1, S3, S5 and S8 ) / SA 516 GR 70 (with S1,S5,S8 )	TEST CERTIFICATE	✓	V	V	V	
2	WELD SEAM OF BLANKS (IF APPLICABLE)	1. PT ON WELD EDGE PREPARATION	MAJOR	NDE	100%		ASME SEC.V ARTICLE 6	ASME SEC.VIII DIVISION I APPENDIX 8	SUPPLIER TC	✓	P	V	V	
		2. RT OF WELD JOINT BEFORE FORMING	MAJOR	NDE	100%		ASME SEC.V ARTICLE 2	ASME SEC.VIII DIVISION 1 UW 51	IR	✓	P	V	V	
		3. MECHANICAL TEST ON TEST COUPON	MAJOR	VISUAL	SAMPLE			SA 387 GR.12 CLASS 2 / SA 516 GR 70	SA 387 GR.12 CLASS 2 / SA 516 GR 70	SUPPLIER TC	✓	P	W / V	V
3	IN PROCESS	1 UT OF PLATE BEFORE FORMING	MAJOR	NDE	100%		SA 435	SA 435	SUPPLIER TC/IR	✓	P	V	V	NOTE 1
		2 DIMENSIONAL CONFORMITY INCLUDING CHECKING FOR MINIMUM THICKNESS	MAJOR	MEASUREMENT	100%		BHEL DRAWING	BHEL DRAWING	IR	✓	P	W	W	
		3 RT ON WELD SEAM AFTER FORMING (IF APPLICABLE)	MAJOR	NDE	100%		ASME SEC VIII ARTICLE 2	ASME SEC VIII DIVISION I UW 51	IR,RT FILM	✓	P	V	V	
		4 VERIFICATION OF PWHT CHARTS FOR NORMALISING AFTER FORMING	MAJOR	VISUAL	100%		ASME SEC VIII DIVISION I UCS 56	ASME SEC VIII DIVISION I UCS 56	HT CHART,IR	✓	P	V	V	

 ALOK BEHERA SR.ENGR/QA	 DS SATPUTE AGM/QA	LEGEND: * RECORDS IDENTIFIED WITH (✓) SHALL BE ESSENTIALLY INCLUDED BY SUPPLIER IN QA DOCUMENTATION, M-MANUFACTURER / SUB-SUPPLIER, C-MAIN SUPPLIER / MAIN SUPPLIER TPIA. N-NTPC. INDICATE "P" PERFORM "W" WITNESS AND "V" VERIFICATION. AS APPROPRIATE "CHP" NTPC SHALL IDENTIFY IN COLUMN "N" AS "W"		DOC.NO 9585-001-110-QVM-Q-871C CAT-I		
MAIN SUPPLIER						
SIGNATURE				FOR NTPC USE	REVIEWED BY	APPROVED BY

	MANUFACTURER'S NAME & ADDRESS: <b>BHARAT HEAVY ELECTRICALS LTD. HYDERABAD</b>	MANUFACTURING QUALITY PLAN				PROJECT: 3 X 800 MW PATRATU STP EXPANSION PHASE -I PACKAGE: TG & AUX CONTRACT NO: CS- 9585-001 MAIN SUPPLIER: HPEP, BHEL HYDERABAD BHEL SALE ORDER NO: M-PA-1062-001,002 & 003				
		ITEM: <b>DISHED END ( CS &amp; AS )</b> <b>HE 51370 REV 00</b> <b>HE 51527 REV 00</b>	QP No : 9585-001-110-QVM-Q-871C Rev. No.:00 DATE: 09.04.2019							

SL NO	COMPONENT & OPERATION	CHARACTERISTICS	CLASS	TYPE OF CHECK	QUANTUM OF CHECK		REFERENCE DOCUMENT	ACCEPTANCE NORMS	FORMAT OF RECORD	AGENCY			REMARKS	
					M	C/N				M	C	N		
1.	2.	3.	4.	5.	6.		7.	8.	9.	D*	** 10.			11.

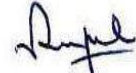
3	IN PROCESS	5 PT / MT ON ENTIRE SURFACE AFTER FORMING	MAJOR	NDE	100%	ASME SEC.V ARTICLE 6/7	ASME SEC.VIII DIVISION 1 APPENDIX 8/6	IR	✓	P	V	V	
4	IN PROCESS /FINAL	6 CHECK FOR THICKNESS AFTER REMOVAL OF SCALES	MAJOR	MEASUREMENT	100%	BHEL DRAWING	BHEL DRAWING	IR		P	V	V	
		7 MT OF WELD SEAMS ON INSIDE AND OUTSIDE SURFACES AFTER FORMING AND NORMALISATION (IF APPLICABLE)	MAJOR	NDE	100%	ASME SEC.V ARTICLE 7	ASME SEC.VIII DIVISION 1 APPENDIX 6	IR	✓	P	W	V	
		8 UT ON OUTER SURFACE AFTER FORMING	MAJOR	NDE	100%	SA 435	SA 435	IR	✓	P	W	W	
		9 LIFTING LUG ARRGT PT LIFTING LUG WELD	MAJOR	VISUAL NDE	100%	BHEL DRG, ASME SEC.V ARTICLE 6	BHEL DRG,ASME SEC.VIII DIVISION 1 APPENDIX 8	IR	✓	P	W	V	
		10 MATCHING OF DISHED ENDS DIAMETER	MAJOR	MEASRT	100 %	BHEL DRG,SPEC	BHEL DRG,SPEC	IR	✓	P	V		NOTE -5
		11 MARKING OF DISHED ENDS	MAJOR	VISUAL	100%	BHEL DRAWING,SPEC	BHEL DRAWING,SPEC	IR	✓	P	V		
		12 MECHANICAL TESTS ON TEST COUPON	MAJOR	VISUAL	SAMPLE	SA 387 GR.12 CLASS 2 / SA 516 GR 70	SA 387 GR.12 CLASS 2 / SA 516 GR 70	IR	✓	P	W /V	V	NOTE -4



 ALOK BEHERA SR.ENGR/QA	 DS SATPUTE AGM/QA	LEGEND: * RECORDS IDENTIFIED WITH (✓) SHALL BE ESSENTIALLY INCLUDED BY SUPPLIER IN QA DOCUMENTATION, M.MANUFACTURER / SUB-SUPPLIER, C-MAIN SUPPLIER / MAIN SUPPLIER TPIA. N-NTPC. INDICATE "P" PERFORM "W" WITNESS AND "V" VERIFICATION. AS APPROPRIATE "CHP" NTPC SHALL IDENTIFY IN COLUMN "N" AS "W"		DOC.NO 9585-001-110-QVM-Q-871C CAT -I			
MAIN SUPPLIER				FOR NTPC USE	REVIEWED BY	APPROVED BY	APPROVAL SEAL
SIGNATURE							

	MANUFACTURER'S NAME & ADDRESS: <b>BHARAT HEAVY ELECTRICALS LTD. HYDERABAD</b>		MANUFACTURING QUALITY PLAN				PROJECT: 3 X 800 MW PATRATU STP EXPANSION PHASE -I PACKAGE: TG & AUX CONTRACT NO: CS- 9585-001 MAIN SUPPLIER: HPEP, BHEL HYDERABAD BHEL SALE ORDER NO: M-PA-1062-001,002 & 003							
	ITEM: <b>DISHED END ( CS &amp; AS )</b> <b>HE 51370 REV 00</b> <b>HE 51527 REV 00</b>		QP No : 9585-001-110-QVM-Q-871C Rev. No.:00 DATE: 09.04.2019											
SL NO	COMPONENT & OPERATION	CHARACTERISTICS	CLASS	TYPE OF CHECK	QUANTUM OF CHECK		REFERENCE DOCUMENT	ACCEPTANCE NORMS	FORMAT OF RECORD		AGENCY			REMARKS
					M	C/N				D*	M	C	N	
1.	2.	3.	4.	5.	6.		7.	8.	9.	D*	** 10.			11.

**Notes:**



- NOT REQUIRED IF ALREADY UT TESTED AT MILL.
- PROJECT SPECIFIC REQUIREMENTS, IF ANY, AS PER P.O. SHALL ALSO BE COMPLIED WITH.
- ALL REQUIREMENTS AS PER BHEL SPECIFICATION AND DRAWING ARE TO BE COMPLIED WITH.
- VALID IBR TC SHALL BE FURNISHED AS PER IBR 1950 REGULATION. VERIFICATION SHALL BE BY BHEL /BHEL TPIA **IF TEST COUPONS ARE WITNESSED BY IBR**
- WHEN DISHED ENDS ARE ORDERED IN PAIRS FOR SINGLE SHELL.
- IN CASE OF SPINNING METHOD IS ADOPTED, THE CENTRAL HOLE SHALL BE PLUGGED AND RADIOGRAPHED 100%. REVIEW OF RT FILMS BY BHEL TPI
- VERIFICATION OF WPS, WPQ AS PER ASME SEC-IX BY BHEL TPIA.
- MATERIAL OF CONSUTRCTION SHALL BE AS PER NTPC APPROVED GA DRAWING OF EQUIPMENT.
- IN CASE OF DIFFERING/CONFLICTING REQUIREMENTS, ANOMALIES, ANY DRAWING/SPECN SHALL PREVAIL OVER QUALITY PLAN
- THIS QP IS APPLICABLE ONLY FOR NTPC APPROVED VENDORS AS PER LOA APPROVED VENDOR LIST FOR PATRATU
- THIS QP IS APPLICABLE FOR THE MAIN AS WELL AS SUBSEQUENT SPARE SUPPLIES.
- FOR IMPORTED VENDORS, BHEL & NTPC WITNESS SHALL BE CONSIDERED VERIFICATION
- HOT FORMED DISHED ENDS SHALL BE NORMALIZED EVEN IF HOT FORMING DONE AT NORMALIZING TEMPERATURE**

GENERAL LEGENDS					
NDE	NON DESTRUCTIVE EXAMINATION	ASSLY	ASSEMBLY	CHEM	CHEMICAL
UT	ULTRASONIC TEST	QC	QUALITY CONTROL	MECH	MECHANICAL
PT	DYE PENETRANT TEST	TPIA	THIRD PARTY INSPECTION AGENCY	TC	TEST CERTIFICATES
MT/MPI	MAGENTIC PARTICLE INSPECTION	WPS	WELDING PROCEDURE SPECIFICATION	VERFN	VERIFICATION
RT	RADIOGRAPHY TEST	WQR	WELDER QUALIFICATION RECORD	IGC	INTER GRANULAR CORROSSION
MEASRT	MEASUREMENT	PQR	PROCEDURE QUALIFICATION RECORD	HT	HEAT TREATMENT
DIMN	DIMENSION	IR	INSPECTION REPORT	QA	QUALITY ASSURANCE
COC	CERTIFICATE OF COMPLIANCE	DRG /DS	DRAWING /DATA SHEET	PO	PURCHASE ORDER

 ALOK BEHERA SR.ENGR/QA	 DS SATPUTE AGM/QA	LEGEND: * RECORDS INDENTIFIED WITH (✓) SHALL BE ESSENTIALLY INCLUDED BY SUPPLIER IN QA DOCUMENTATION, M.MANUFACTURER / SUB-SUPPLIER, C-MAIN SUPPLIER / MAIN SUPPLIER TPIA. N-NTPC. INDICATE "P" PERFORM "W" WITNESS AND "V" VERIFICATION. AS APPROPRIATE "CHP" NTPC SHALL IDENTIFY IN COLUMN "N" AS "W"		DOC.NO 9585-001-110-QVM-Q-871C CAT-I		
MAIN SUPPLIER						
SIGNATURE				FOR NTPC USE	REVIEWED BY	APPROVED BY

	MANUFACTURER'S NAME & ADDRESS: <b>BHARAT HEAVY ELECTRICALS LTD. HYDERABAD</b>		MANUFACTURING QUALITY PLAN				PROJECT: 3 X 800 MW PATRATU STP EXPANSION PHASE -I PACKAGE: TG & AUX CONTRACT NO: CS- 9585-001 MAIN SUPPLIER: HPEP, BHEL HYDERABAD BHEL SALE ORDER NO: M-PA-1062-001,002 & 003							
	ITEM: <b>DISHED END ( CS &amp; AS )</b> <b>HE 51370 REV 00</b> <b>HE 51527 REV 00</b>		QP No : 9585-001-110-QVM-Q-871C Rev. No.:00 DATE: 09.04.2019											
SL NO	COMPONENT & OPERATION	CHARACTERISTICS	CLASS	TYPE OF CHECK	QUANTUM OF CHECK		REFERENCE DOCUMENT	ACCEPTANCE NORMS	FORMAT OF RECORD		AGENCY			REMARKS
					M	C/N				D*	M	C	N	
1.	2.	3.	4.	5.	6.	7.	8.	9.	D*	**10.			11.	

APPROVED SUB VENDORS OF PATRATU ALONG WITH APPROVAL CONDITION AS MENTION IN LOA .	
1. METAL ENGINEERS -HYDERABAD	Bala Nagar, Hyderabad
2. SATYA FABRICATORS - HYDERABAD	PLOT NO.1-B, SURVEY NO.308,SRI VENKATESWARA CO.OP INDL. ESTATE,JEEDIMETLA, 500055 HYDERABAD
3. MAHENDRA DISHED ENDS -THANE	WAGEL INDUSTRIAL ESTATE,PLOT NO. B-13, ROAD NO. 12, 400604 , THANE
4. CEREC – VADODARA	295, N. H. 8, MANGLEJ, KARJ <b>AN</b> 391210 VADODARA
5. CEREC – FRNACE	2, RUE RENE FOURCHET,B.P.2, 59245 RECQUIGNIES, FRANCE.
6. ANUP ENGINEERING LTD -INDIA	BEHIND 66 KV ELECTRICAL,SUB STATION ODHAV ROAD,382415 AHMEDABAD
7. KONIG & CO – GERMANY	POST FACH-1262, D-57236 NETPHEN, GERMANY.
8. ICEM ENGINEERING - THANE	M.S.ROAD, RAGHUNATH NAGAR, THANE

 ALOK BEHERA SR.ENGR/QA	 DS SATPUTE AGM/QA	LEGEND: * RECORDS IDENTIFIED WITH (✓) SHALL BE ESSENTIALLY INCLUDED BY SUPPLIER IN QA DOCUMENTATION, M.MANUFACTURER / SUB-SUPPLIER, C-MAIN SUPPLIER / MAIN SUPPLIER TPIA. N-NTPC. INDICATE "P" PERFORM "W" WITNESS AND "V" VERIFICATION. AS APPROPRIATE "CHP" NTPC SHALL IDENTIFY IN COLUMN "N" AS "W"		DOC.NO 9585-001-110-QVM-Q-871C CAT -I		
MAIN SUPPLIER						
SIGNATURE				FOR NTPC USE	REVIEWED BY	APPROVED BY

INVENTORY NO. SIGN. AND DATE REF. DRG. NO. THE INFORMATION ON THIS DOCUMENT IS THE PROPERTY OF BHARAT HEAVY ELECTRICALS LIMITED. IT MUST NOT BE USED DIRECTLY OR INDIRECTLY IN ANY WAY DETRIMENTAL TO THE INTEREST OF THE COMPANY

FIRST ANGLE PROJECTION

(ALL DIMENSIONS ARE IN mm)

DRG. NO. 3-163-11-14121

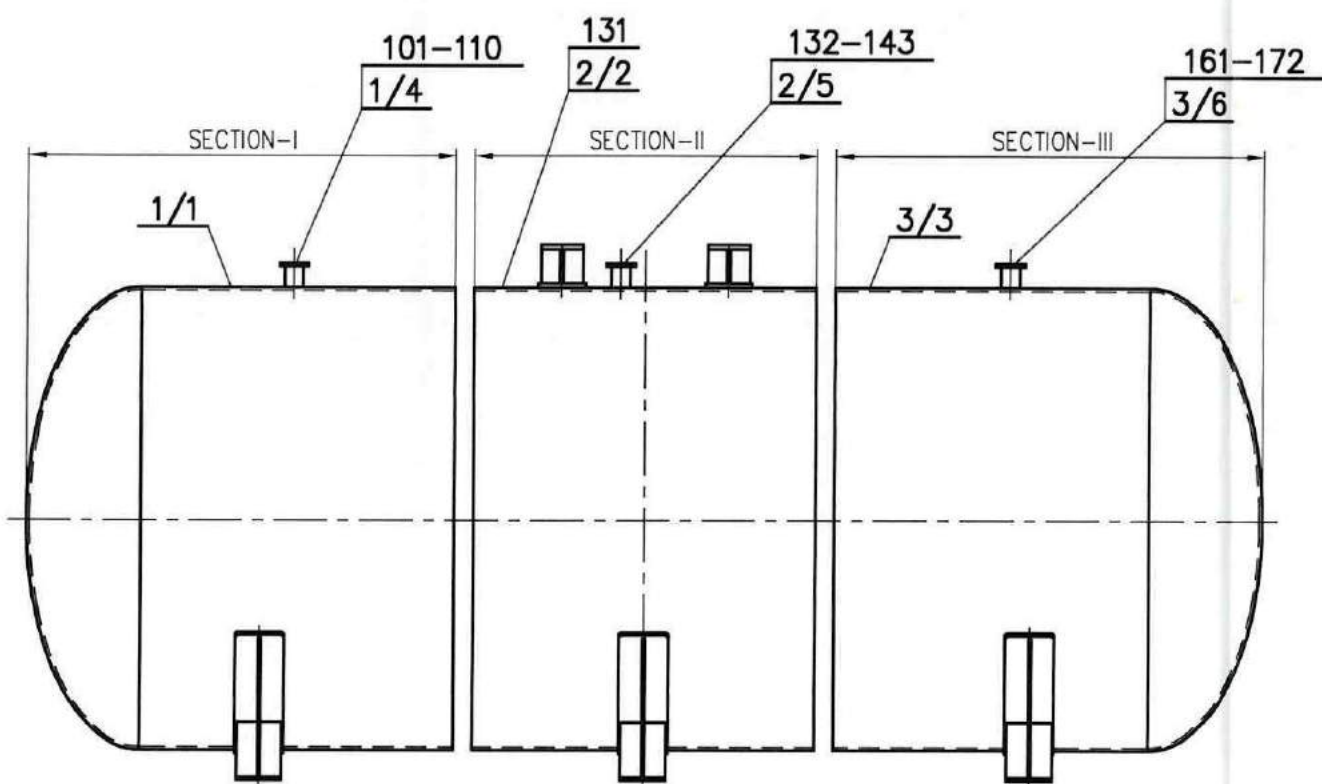

**NOTES:**

1. POS. NO. 1/1 FOR SHELL ASSLY. SEC-I, REFER DRG NO. 1-163-11-11487
2. POS. NOS. 2/2, 131 FOR SHELL ASSLY. SEC-II, REFER DRG NO. 1-163-11-11487
3. POS. NO. 3/3 FOR SHELL ASSLY. SEC-III, REFER DRG NO. 1-163-11-11487
4. POS. NOS. 1/4, 101-110 FOR NOZZLE ASSLY. SEC-I, REFER DRG NO. 1-163-11-11488
5. POS. NOS. 2/5, 131-143 FOR NOZZLE ASSLY. SEC-II, REFER DRG NO. 1-163-11-11488
6. POS. NOS. 3/6, 161-172 FOR NOZZLE ASSLY. SEC-III, REFER DRG NO. 1-163-11-11488

**TABLE-I**

STORAGE TANK SECTION. NO.	DES. WT. IN (Kg)	TOTAL WT. IN (Kg)	HEADER MATL. NO.	VESSEL NO.	W.O WBSE
SECTION-I	60588	63105	T31631114121-00A	1953	W-1032418000
				1957	W-1032418100
				1961	W-1032418200
SECTION-II	44812	46428	T31631114121-00B	1954	W-1032418000
				1958	W-1032418100
				1962	W-1032418200
SECTION-III	59919	61267	T31631114121-00C	1955	W-1032418000
				1959	W-1032418100
				1963	W-1032418200

**DESIGN DATA**

DESCRIPTION		
DESIGN PRESSURE	Kg/sq.cm (g)	15.5 & FULL VACUUM
TEST PRESSURE	Kg/sq.cm (g)	23.25
DESIGN TEMPERATURE MAX/MIN	°C	260/ 0
TEST TEMPERATURE MAX/MIN	°C	AMBIENT/ 17
CORROSION ALLOW.	SHELL/ HEADS	3.2
	RF PADS/ NOZZLES/ FLANGES mm	1.6
RADIO GRAPHY		100%
JOINT EFFICIENCY		1.0
INSPECTION		APPROVED QP
TOTAL WEIGHT OF ST.TANK	KG	REFER TABLE-1
DESPATCH WEIGHT	KG	REFER TABLE-1
PWHT		REQUIRED

**IMPORTANT NOTE:-**

- SURFACE PREPARATION STD: SA 2 1/2-SAND/GRIT BLAST THE EXTERIOR OF THE VESSEL.
- 1) PAINTING INSIDE: STEAM WASHABLE PAINT AS PER AA55151.  
OUTSIDE FINISH PAINT: TWO COATS OF HEAT RESISTANTING AIR DRYING ALUMINIUM  
TOTAL DFT: 40 MICRONS
  - 2) FOR NAME PLATE DETAILS REFER DRG. 4-163-11-14191.

DB/TS 1606/59 /2020  
**APPROVED**

DESIGN, FABRICATION & TESTING CODE	ASME SEC VIII DIV.1-2017
W.O WBSE	REFER TABLE
S.O WBSE	M-PA-1062
CUSTOMER DRG.No. / VESSEL NO.	HY-DG-A-16310-95501/ REFER TABLE-I
WELD DET.& WPS DRG.No.	2 163 10 00014
NOZZLE DETAIL DRG. No.	1 163 10 11178
HEADER MATERIAL NO.	REFER TABLE-I

TYPE OF PRODUCT OR NAME OF CUSTOMER/PROJECT **3X800MW NTPC PATRATU**



**BHARAT HEAVY ELECTRICALS LTD. HYDERABAD**

DRN.	NAME	SIGN.	DATE	NO.OF VAR.
B	VENKANNA	[Signature]	09.07.20	
CHD.	BINAY K JHA	BINAY K JHA	09.07.20	NA
APPD.	SUBRATA RAY	SUBRATA RAY	09.07.20	

REV.	DATE	ALTERED	CHECKED	APPD	DEPT. HEE	GRADE OF TOL.DIM. C/M/F	SCALE	WEIGHT (KG)	REF. TO ASSY DRG.	ITEM NO.	NO.OF ITEMS
					405		NTS	NA	NA	NA	NA
TITLE								CARD CODE	DRAWING NO.	REV.	
ST.TANK ASSLY. (DEAERATOR)									3-163-11-14121	00	
								SHEET No.	NO OF SHEETS		

FIRST ANGLE PROJECTION

(ALL DIMENSIONS ARE IN mm)

REV.	DATE	ALTERED	CHECKED	APPD	REV.	DATE	ALTERED	CHECKED	APPD	ADDITIONAL INFORMATION
										STATUS OF DRAWING
										DISTURIBUTION OF PRINTS

THE INFORMATION ON THIS DOCUMENT IS THE PROPERTY OF BHARAT HEAVY ELECTRICALS LIMITED. IT MUST NOT BE USED DIRECTLY OR INDIRECTLY IN ANY WAY DETRIMENTAL TO THE INTREST OF THE COMPANY.

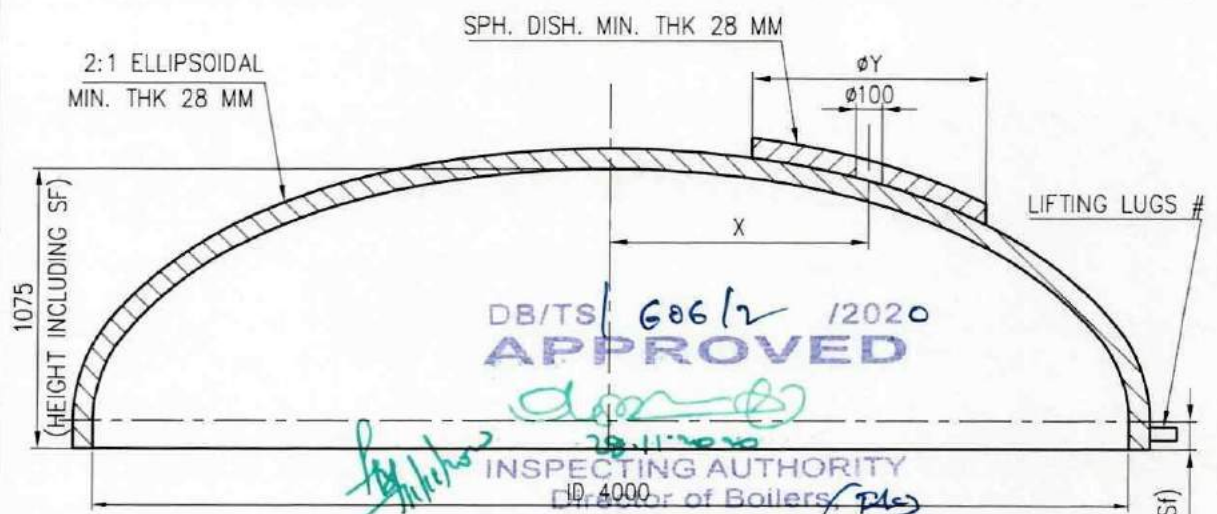

ITEM	Y	X
01	950	1000
02	700	1200

DESIGN PRESSURE: 15.5 Kg/sq.cm (g)  
 DESIGN TEMPERATURE: 260° C

**NOTES**

- MATERIAL SHALL CONFIRM TO SA516 Gr.70 OF ASME SEC-II PART-A YEAR OF EDITION AS PER INDENT/ PO.
- INSPECTION: BY M/s IBR/DOB & BHEL APPROVED TPIA.
- CERTIFICATION: IBR FORM III-C.
- DESIGN CODE: IBR REGULATIONS (CLASS-1 BOILER).
- PLATE SHALL BE UT TESTED BEFORE FORMING (NOT REQUIRED IF ALREADY UT TESTED AT MILLS)
- SPHERICAL DISH SHALL BE OF SEAMLESS CONSTRUCTION & PROFILE SHOULD MATCH WITH DISHED DISHED END OD AS SHOWN IN THE DRG.
- NORMALISING SHALL BE DONE FOR SPHERICAL DISH ALSO AFTER PRESSING.
- TEST COUPON TESTING IS REQUIRED.
- TECHNICAL & DELIVER CONDITIONS: AS PER PRODUCT STANDARD HE51370.

FOR PLATE WELDING REFER DRG. 4-163-10-00685.

# 3 NOS. LIFTING LUGS TO BE WELDED ON Sf AT 120° AND TO BE DP CHECKED AFTER WELDING.

ITEM NO.	DESCRIPTION	DRAWING NO.	MATL. CODE	UNIT WT.
			MATL. SPEN.	QTY.
BHARAT HEAVY ELECTRICALS LTD. HYDERABAD		DRN.	NAME B.VENKANNA	DATE 28.09.18
		CHD.	BINAY KR JHA	28.09.18
		APPD.	SUBRATA RAY	28.09.18

DEPT. HED	GRADE OF TOL. DIM. C/M/F	SCALE NTS	WEIGHT (KG)	REF. TO ASSY DRG.	ITEM NO.	NO.OF ITEMS
405						

TITLE	CARD CODE	DRAWING NO.	REV.
SPHERICAL DISH WITH 2:1 ELLIPSOIDAL DISHED END		4-163-10-00684	00

FIRST ANGLE PROJECTION

(ALL DIMENSIONS ARE IN mm)

INVENTORY NO. SIGN. AND DATE REF. DRG. NO. THE INFORMATION ON THIS DOCUMENT IS THE PROPERTY OF BHARAT HEAVY ELECTRICALS LIMITED. IT MUST NOT BE USED DIRECTLY OR INDIRECTLY IN ANY WAY DETRIMENTAL TO THE INTEREST OF THE COMPANY

REV.	DATE	ALTERED	CHECKED	APPD	REV.	DATE	ALTERED	CHECKED	APPD	ADDITIONAL INFORMATION
					01	02.7.18	VENKANNA	BINAY K JHA	S RAY	STATUS OF DRAWING
										DISTURIBUTION OF PRINTS

REVISED IN-LINE WITH SS TEST COUPONS REQUIREMENT.

VAR	PL. THK.	Wt-Kg
01	10	7.71
02	12	9.25
03	14	10.79
04	16	12.33
05	18	13.88
06	20	15.42
07	22	16.96
08	25	19.27
09	28	21.58
10	32	24.67
11	36	27.75
12	40	30.83
** 13	08	6.27

DB/TS/606/18/2020  
**APPROVED**

*[Signature]*  
INSPECTING AUTHORITY  
Director of Boilers,  
Telangana State, Hyderabad.

NOTE :- MATERIAL TO BE CUT ALONG WITH SHELL / ROLLED PIPE MATERIAL  
MATERIAL SPECIFICATION: CS TO SA 516 Gr.70  
SIZE 280X350

\*\* MATERIAL SPECIFICATION: SS TO SA240 TP304L AND SIZE:280X350.

ITEM NO.	DESCRIPTION	DRAWING NO.	MATL. CODE	UNIT Wt.
			MATL. SPEN.	QTY.
 BHARAT HEAVY ELECTRICALS LTD. HYDERABAD		DRN. B UMA	NAME SIGN.	DATE NO.OF VAR.
		CHD. UMESH MENON		13.04.15
		APPD. ACS		13.04.15
DEPT. HED	GRADE OF TOL.DIM. C/M/F	SCALE NTS	WEIGHT (KG)	REF. TO ASSY DRG.
CODE 405				ITEM NO. NO.OF ITEMS
TITLE		CARD CODE	DRAWING NO.	REV.
TEST COUPONS (FOR DEAEERATOR)			4-163-10-00617	01
<small>Aug Tue 14 10:00 2016</small> <small>Printed by: VENKANNA-WME8041 / 6007767 on 23-10-19</small>		<small>This Drawing is printed from Engineering Digital Archive System (EDAS) therefore signature is not legally required.</small>		

INVENTORY NO. SIGN. AND DATE REF. DRG. NO. THE INFORMATION ON THIS DOCUMENT IS THE PROPERTY OF BHARAT HEAVY ELECTRICALS LIMITED. IT MUST NOT BE USED DIRECTLY OR INDIRECTLY IN ANY WAY DETRIMENTAL TO THE INTEREST OF THE COMPANY

DRG. NO. 3-163-16-11664

FIRST ANGLE PROJECTION

(ALL DIMENSIONS ARE IN mm)

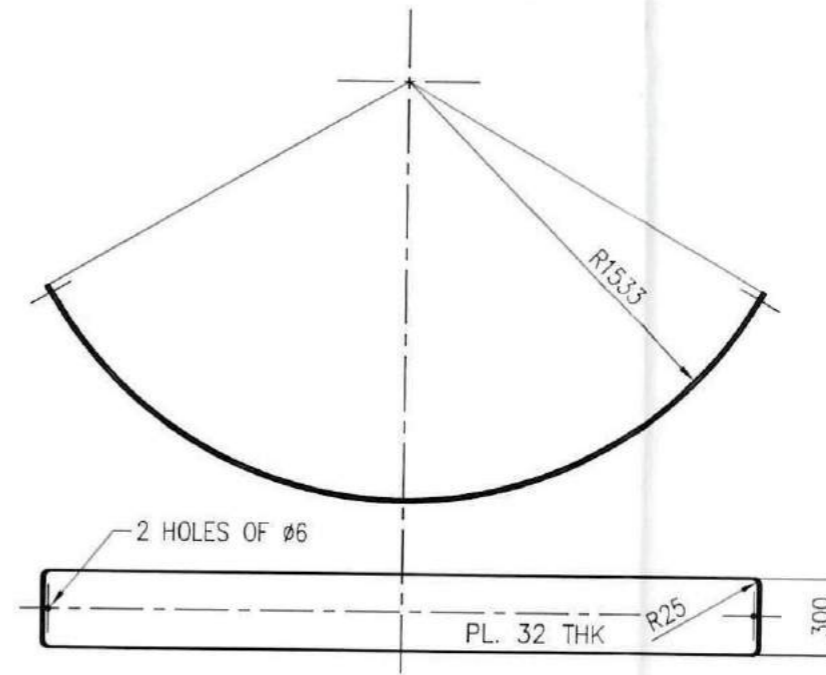
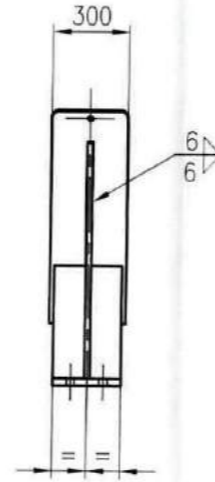
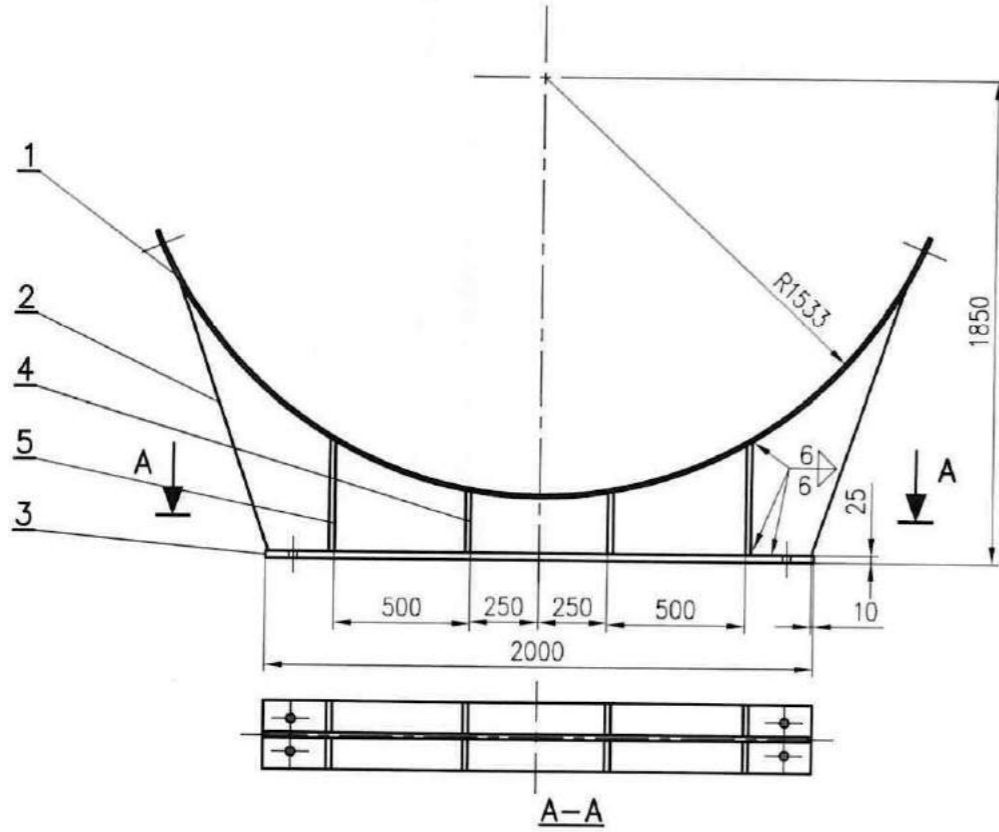

POS-1  
(DEVELOPED LENGTH= 3568)

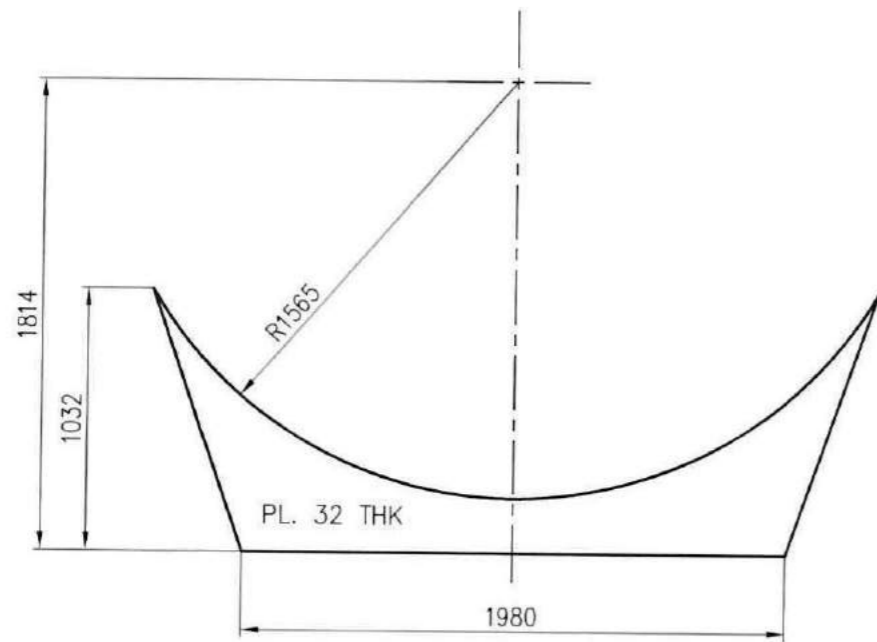

POS-2

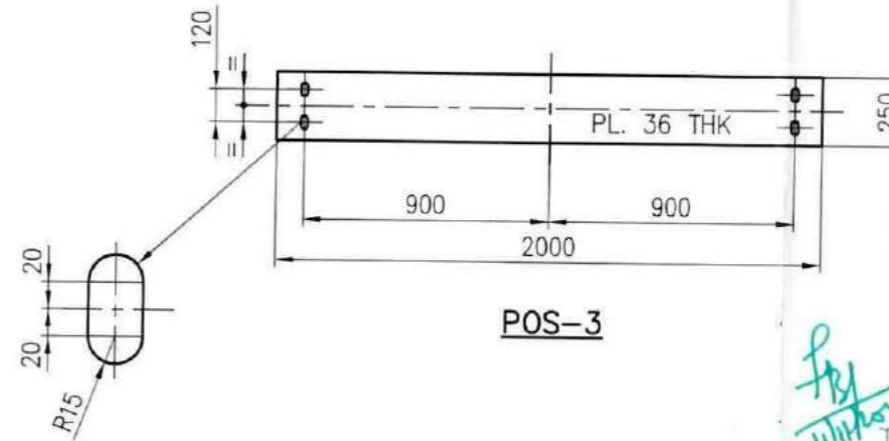

POS-3

DB/TS 1606/60/2020  
APPROVED

28-11-2020  
INSPECTING AUTHORITY  
Director of Boilers  
Telangana State, Hyderabad.

TYPE OF PRODUCT OR NAME OF CUSTOMER/PROJECT



BHARAT HEAVY ELECTRICALS LTD.  
HYDERABAD

DRN.	NAME A.L. RAJAM	DATE 01.09.10	NO. OF VAR.
CHD.	UMESH MENON	01.09.10	NA
APPD.	B SRINIVAS	01.09.10	NA

REV.	DATE	ALTERED	CHECKED	APPD

DEPT. HEE	GRADE OF TOL. DIM. C/M/F	SCALE NTS	WEIGHT (KG) NA	REF. TO ASSY DRG. NA	ITEM NO. NA	NO. OF ITEMS NA
CODE 405						
TITLE HEATER SUPPORT			CARD CODE	DRAWING NO. 3-163-16-11664		REV. 00
			SHEET No. 1		NO OF SHEETS 1	

19-04-2012  
15:26:51

This Drawing is printed from Engineering Digital Archive System (EDAS). Therefore signatures are not essentially required.

FIRST ANGLE PROJECTION

(ALL DIMENSIONS ARE IN mm)

DRG. NO. 3-163-16-11828

**NOTES:**

1. POS. NO. 1/1 FOR SHELL ASSLY. REFER DRG. NO. 3-163-16-11829
2. POS. NOS. 1/2, 51-61 FOR NOZZLE ASSLY. REFER DRG. NO. 1-163-16-11555
3. POS. NO. 1/3 FOR WATER BOX ASSLY. REFER DRG. NO. 1-163-16-11557
4. POS. NO. 1/4 FOR TRAY ASSLY. REFER DRG. NO. 1-163-16-11503

DB/TS /606/62 /2020  
**APPROVED**

INSPECTING AUTHORITY  
Director of Boilers / A.C.  
Telangana State, Hyderabad.

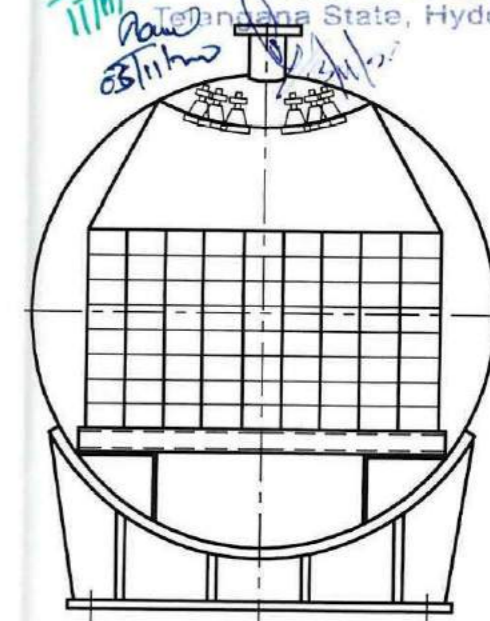
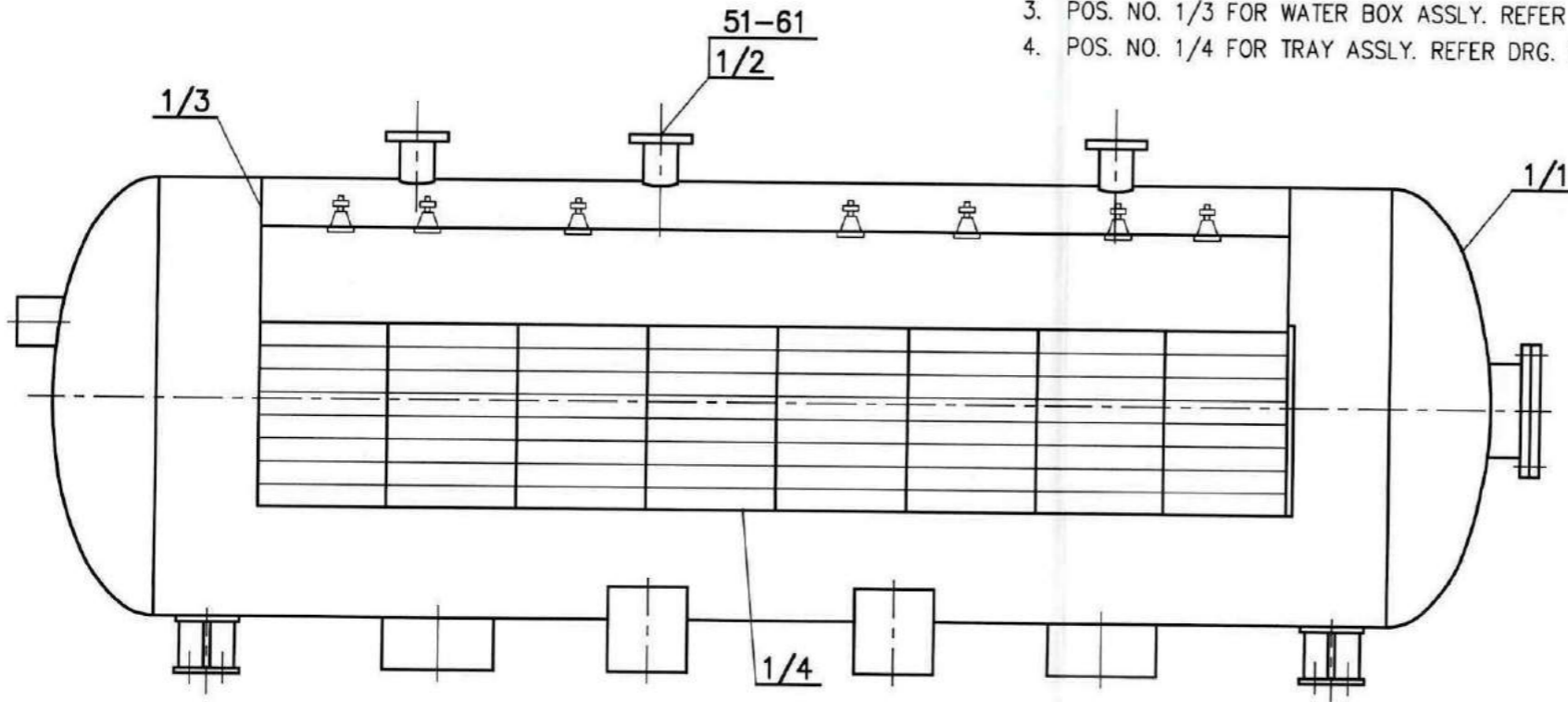

**DESIGN DATA**

DESCRIPTION		
DESIGN PRESSURE	Kg/sq.cm (g)	15.5 & FULL VACUUM
TEST PRESSURE	Kg/sq.cm (g)	27.44
DESIGN TEMPERATURE MAX/MIN	°C	400/0
TEST TEMPERATURE MAX/MIN	°C	AMBIENT/ 20
CORROSION ALLOW.	SHELL/ HEADS	3.2
IN mm	RF PADS/ NOZZLES/ FLANGES mm	1.6
RADIO GRAPHY		100%
JOINT EFFICIENCY		1.0
INSPECTION		APPROVED QP & IBR/DOB
TOTAL WEIGHT OF HEATER	KG	56158
DESPATCH WEIGHT	KG	54973
PWHT		REQUIRED

DESIGN, FABRICATION & TESTING CODE	IBR CHAPTER-XII (CLASS-1 BOILER), ASME SEC VIII DIV.1-2017, HEI-2011
W.O WBSE	W-10324180/81/8200
S.O WBSE	M-PA-1062
CUSTOMER DRG.No. / VESSEL NO.	HY-DG-1-16310-95501/ 1952,1956&1925
WELD DET.& WPS DRG.No.	2-163-10-00014
NOZZLE DETAIL DRG. No.	1-163-10-11178
HEADER MATERIAL NO.	T31631611828-00

TYPE OF PRODUCT OR NAME OF CUSTOMER/PROJECT **NTPC PATRATU STP EXPANSION 3x800MW**

**IMPORTANT NOTE:-**

- 1) PAINTING INSIDE: NIL  
OUTSIDE: TWO COATS OF HEAT RESISTANT ALUMINIUM PAINT AS PER IS 13183 GR-1(Total DFT 40microns)



**BHARAT HEAVY ELECTRICALS LTD. HYDERABAD**

DRN.	NAME	SIGN.	DATE	NO.OF VAR.
B.VENKANNA	B.VENKANNA	[Signature]	04.10.19	NA
BINAY KR JHA	BINAY KR JHA	[Signature]	04.10.19	NA
SUBRATA RAY	SUBRATA RAY	[Signature]	04.10.19	NA

REV.	DATE	ALTERED	CHECKED	APPD	DEPT. HEE	GRADE OF TOL.DIM. C/M/F	SCALE	WEIGHT (KG)	REF. TO ASSY DRG.	ITEM NO.	NO.OF ITEMS
ZONE					405		NTS	NA	NA	NA	NA
TITLE <b>HEATER ASSLY. (DEAERATOR)</b>								CARD CODE	DRAWING NO. <b>3-163-16-11828</b>		REV. <b>00</b>
								SHEET No.	NO OF SHEETS		

INVENTORY NO. SIGN. AND DATE REF. DRG. NO. THE INFORMATION ON THIS DOCUMENT IS THE PROPERTY OF BHARAT HEAVY ELECTRICALS LIMITED. IT MUST NOT BE USED DIRECTLY OR INDIRECTLY IN ANY WAY DETRIMENTAL TO THE INTEREST OF THE COMPANY

FIRST ANGLE PROJECTION

(ALL DIMENSIONS ARE IN mm)

DRG. NO. 3-163-16-11829

INVENTORY NO. SIGN. AND DATE REF. DRG. NO. THE INFORMATION ON THIS DOCUMENT IS THE PROPERTY OF BHARAT HEAVY ELECTRICALS LIMITED. IT MUST NOT BE USED DIRECTLY OR INDIRECTLY IN ANY WAY DETRIMENTAL TO THE INTEREST OF THE COMPANY

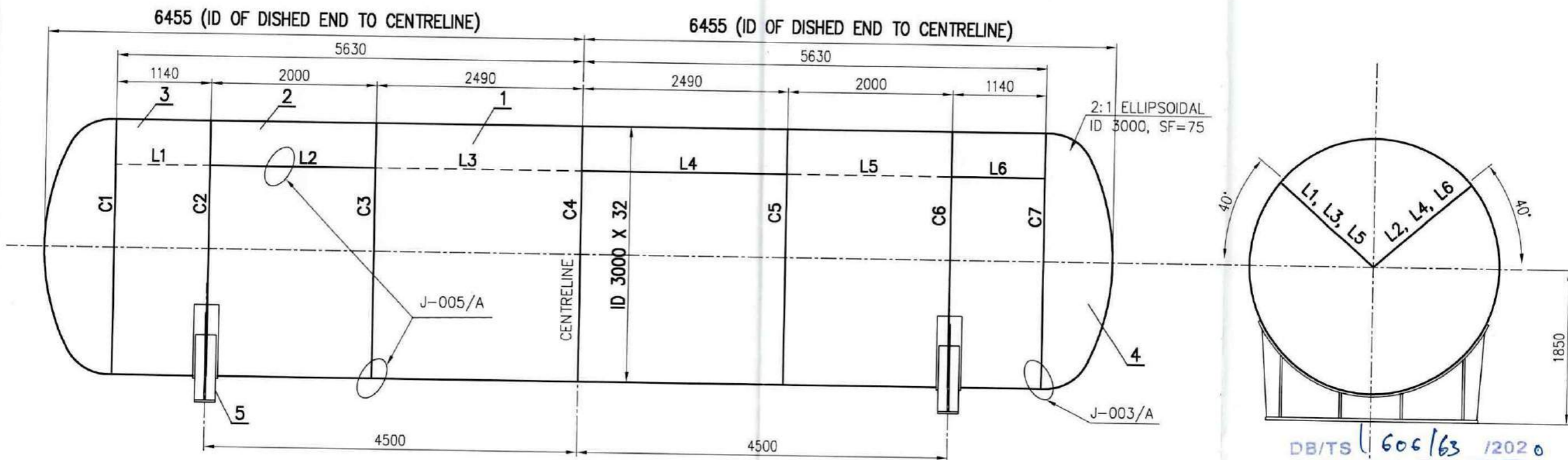

**NOTE: -**

1. DETAIL OF WELDS & WPS. NOS. REF. DRG. NO. 2-163-10-00014
2. RADIO GRAPHY ----- 100 %
3. ALL LONGITUDINAL & CIRCUMFERENTIAL WELDS ARE TO BE BACK GROUND TO SOUND METAL.
4. DURING THE FIT UP OF DISHED END TO SHELL A REFERENCE LINE SHALL BE MARKED ON THE SHELL AT A DISTANCE OF 100MM FROM THE END OF THE SHELL, WHICH SHALL BE TRANSFERRED BACK AFTER WELDING, TO IDENTIFY WELD LINE.
5. DEVELOPED LENGTH OF POS. NO. 1, 2= 9525.
6. TEST COUPONS REQUIRED FOR ALL LONGITUDINAL SEAMS OF SHELL & DISHED ENDS.

DB/TS 606/63 /2020  
**APPROVED**  
 28.11.2020  
 INSPECTING AUTHORITY  
 Director of Boilers, (P)  
 Telangana State, Hyderabad.

TYPE OF PRODUCT OR NAME OF CUSTOMER/PROJECT  
**NTPC PATRATU STP EXPANSION**  
**3x800MW**



BHARAT HEAVY ELECTRICALS LTD.		DRN.	NAME	SIGN	DATE	NO. OF VAR.
HYDERABAD		CHD.	B.VENKANNA	B.VENKANNA	04.10.19	NA
		APPD.	SUBRATA RAY	SUBRATA RAY	04.10.19	NA

REV.	DATE	ALTERED	CHECKED	APPD	REV.	DATE	ALTERED	CHECKED	APPD
ZONE					ZONE				

DEPT. HEE	GRADE OF TOL. DIM. C/M/F	SCALE NTS	WEIGHT (KG) NA	REF. TO ASSY DRG. NA	ITEM NO. NA	NO. OF ITEMS NA
CODE 405						
TITLE SHELL ASSLY. (FOR DEAERATOR HEATER)			CARD CODE	DRAWING NO. 3-163-16-11829		REV. 00
			SHEET No. 1	NO OF SHEETS 1		

Oct Tue 22 14:59 2019

This Drawing is printed from Engineering Digital Archive System (EDAS). Therefore signatures are not essentially required.

FIRST ANGLE PROJECTION

(ALL DIMENSIONS ARE IN mm)

INVENTORY NO. SIGN. AND DATE REF. DRG. NO. THE INFORMATION ON THIS DOCUMENT IS THE PROPERTY OF BHARAT HEAVY ELECTRICALS LIMITED. IT MUST NOT BE USED DIRECTLY OR INDIRECTLY IN ANY WAY DETRIMENTAL TO THE INTEREST OF THE COMPANY

REV.	DATE	ALTERED	CHECKED	APPD	REV.	DATE	ALTERED	CHECKED	APPD	ADDITIONAL INFORMATION
01	25.11.19	B V	SR	SR	02	03.07.20	B V	SR	SR	STATUS OF DRAWING
REVISED AS INDICATED.					REVISED AS INDICATED.					DISTURBITION OF PRINTS

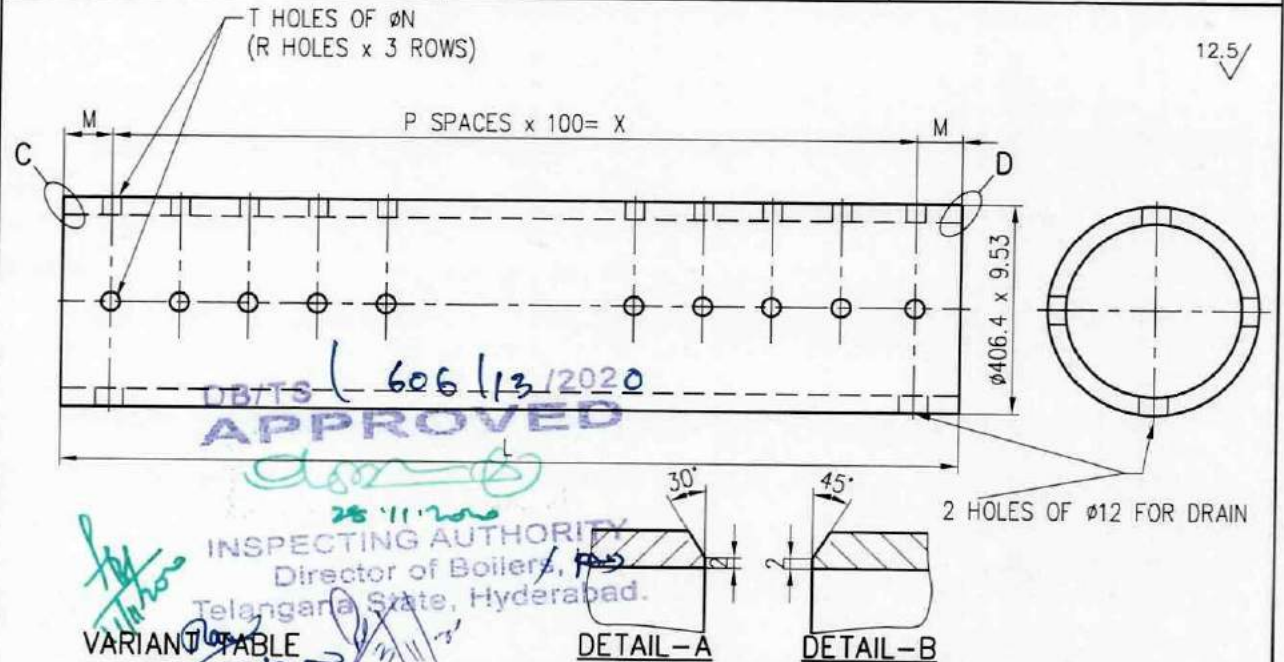

S.NO	L	M	N	P	X	R	T	C	D
01	5990	45	12	59	5900	60	180	DET-A	DET-B
02	5990	45	12	59	5900	60	180	DET-A	DET-A
03	2960	30	12	29	2900	30	90	DET-A	DET-A
04	2960	30	10	29	2900	30	90	DET-A	DET-A
05	5990	45	10	59	5900	60	180	DET-A	DET-A
06	2960	30	8	29	2900	30	90	DET-A	DET-A
07	5990	45	8	59	5900	60	180	DET-A	DET-A
08	4680	40	8	46	4600	47	141	DET-A	DET-A
09	3230	65	10	31	3100	32	96	DET-A	DET-A
10	4205	52.5	12	41	4100	42	126	DET-A	DET-A

ITEM NO.	DESCRIPTION	DRAWING NO.	MATL. CODE	UNIT Wt.
			MATL. SPEN.	QTY.

BHARAT HEAVY ELECTRICALS LTD. HYDERABAD		DRN.	NAME	SIGN.	DATE	NO. OF VAR.
		CHD.	UMESH MENON		09.02.15	
		APPD.	ACS		09.02.15	

DEPT. HED	GRADE OF TOL. DIM. C/M/F		SCALE	WEIGHT (KG)	REF. TO ASSY DRG.	ITEM NO.	NO. OF ITEMS
CODE 405							

TITLE	CARD CODE	DRAWING NO.	REV.
HEATING STEAM PIPE-16"		4-163-11-14135	102

FIRST ANGLE PROJECTION

(ALL DIMENSIONS ARE IN mm)

INVENTORY NO. SIGN. AND DATE REF. DRG. NO. THE INFORMATION ON THIS DOCUMENT IS THE PROPERTY OF BHARAT HEAVY ELECTRICALS LIMITED. IT MUST NOT BE USED DIRECTLY OR INDIRECTLY IN ANY WAY DETRIMENTAL TO THE INTEREST OF THE COMPANY

REV.	DATE	ALT.	CHECK.	APPD.	REV.	DATE	ALT.	CHECK.	APPD.	ADDITIONAL INFORMATION
										STATUS OF DRAWING
										DISTURIBUTION OF PRINTS

12.5/√

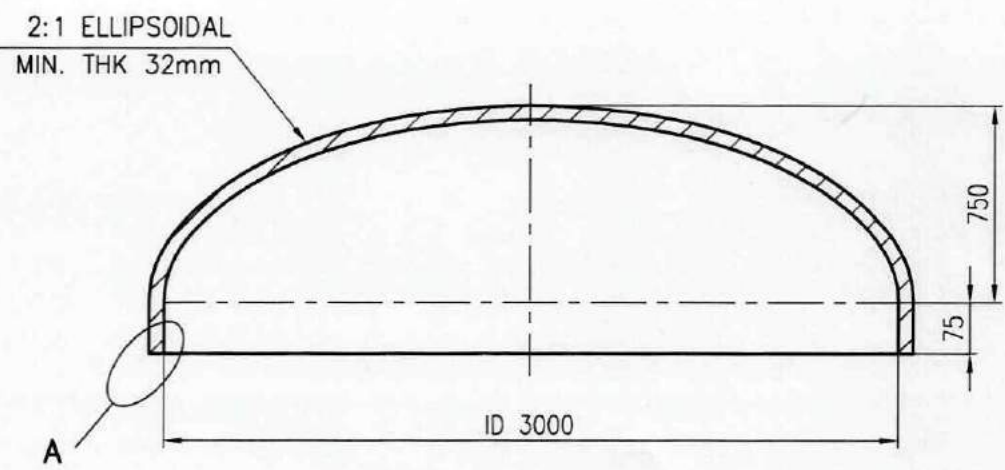

DB/TS 12/54 /2021  
**APPROVED**  
 20.1.21  
 INSPECTING AUTHORITY  
 Director of Boilers, BAW  
 Telangana State, Hyderabad.  
 6/1/21

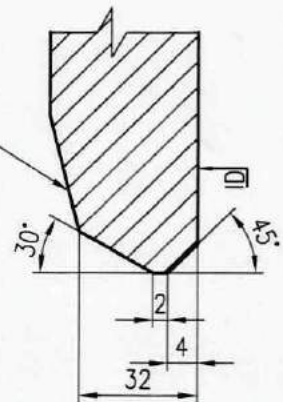

**DETAIL-A**

ITEM NO.	DESCRIPTION	DRAWING NO.	MATL. CODE	UNIT Wt.
			MATL. SPEN.	QTY.

	BHARAT HEAVY ELECTRICALS LTD. HYDERABAD		DRN. B UMA	B SIGN. B UMA	DATE 20.03.18	NO. OF VAR.
			CHD. BINAY K JHA	B SIGN. BINAY K JHA	DATE 20.03.18	
			APPD. SUBRATA RAY	B SIGN. SUBRATA RAY	DATE 20.03.18	

DEPT. HED CODE 405	GRADE OF TOL. DIM. C/M/F		SCALE	WEIGHT (KG)	REF. TO ASSY DRG.	ITEM NO.	NO. OF ITEMS
--------------------	--------------------------	--	-------	-------------	-------------------	----------	--------------

TITLE DISHED END	CARD CODE	DRAWING NO. 4-163-16-13270	REV. 00
---------------------	-----------	-------------------------------	------------