



Bid Number/बोली क्रमांक (बिड संख्या):  
GEM/2023/B/4199194  
Dated/दिनांक : 10-11-2023

### Bid Document/ बिड दस्तावेज़

Bid Details/बिड विवरण	
Bid End Date/Time/बिड बंद होने की तारीख/समय	20-11-2023 19:00:00
Bid Opening Date/Time/बिड खुलने की तारीख/समय	20-11-2023 19:30:00
Bid Offer Validity (From End Date)/बिड पेशकश वैधता (बंद होने की तारीख से)	180 (Days)
Ministry/State Name/मंत्रालय/राज्य का नाम	Ministry Of Heavy Industries And Public Enterprises
Department Name/विभाग का नाम	Department Of Heavy Industry
Organisation Name/संगठन का नाम	Bharat Heavy Electricals Limited (bhel)
Office Name/कार्यालय का नाम	10250020-pem, Noida
Total Quantity/कुल मात्रा	531172
Item Category/मद केटेगरी	FLEXIBLE COPPER BRAID FOR GATE EARHTING , GS FLAT 50 X 6 MM , GS FLAT 75 X 10 MM , HOT DIP GALVANISED MS SHEET 14 SWG , TEST LINK 150X75X10 MM GS FLAT WITH BOX , GI WIRE 16 SWG
BOQ Title/बीओक्यू शीर्षक	Above Ground Earthing Material FOR YADADRI PROJECT
MSE Exemption for Years of Experience and Turnover/ अनुभव के वर्षों से एमएसई छूट	No
Startup Exemption for Years of Experience and Turnover/ अनुभव के वर्षों से स्टार्टअप छूट	No
Document required from seller/विक्रेता से मांगे गए दस्तावेज़	Certificate (Requested in ATC),Additional Doc 1 (Requested in ATC),Additional Doc 2 (Requested in ATC),Additional Doc 3 (Requested in ATC),Additional Doc 4 (Requested in ATC),Compliance of BoQ specification and supporting document *In case any bidder is seeking exemption from Experience / Turnover Criteria, the supporting documents to prove his eligibility for exemption must be uploaded for evaluation by the buyer
Bid to RA enabled/बिड से रिवर्स नीलामी सक्रिय किया	Yes
RA Qualification Rule	H1-Highest Priced Bid Elimination
Type of Bid/बिड का प्रकार	Two Packet Bid
Primary product category	GS FLAT 75 X 10 MM

**Bid Details/बिड विवरण**

<b>Time allowed for Technical Clarifications during technical evaluation/तकनीकी मूल्यांकन के दौरान तकनीकी स्पष्टीकरण हेतु अनुमत समय</b>	2 Days
<b>Inspection Required (By Empanelled Inspection Authority / Agencies pre-registered with GeM)</b>	No
<b>Payment Timelines</b>	Payments shall be made to the Seller within <b>60</b> days of issue of consignee receipt-cum-acceptance certificate (CRAC) and on-line submission of bills (This is in supersession of 10 days time as provided in clause 12 of GeM GTC)
<b>Evaluation Method/मूल्यांकन पद्धति</b>	Total value wise evaluation

**EMD Detail/ईएमडी विवरण**

Required/आवश्यकता	No
-------------------	----

**ePBG Detail/ईपीबीजी विवरण**

Advisory Bank/एडवाइजरी बैंक	State Bank of India
ePBG Percentage(%) / ईपीबीजी प्रतिशत (%)	10.00
Duration of ePBG required (Months) / ईपीबीजी की अपेक्षित अवधि (महीने).	24

(a). EMD & Performance security should be in favour of Beneficiary, wherever it is applicable./ईएमडी और संपादन जमानत राशि, जहां यह लागू होती है, लाभार्थी के पक्ष में होनी चाहिए।

**Beneficiary/लाभार्थी :**

HOD FINANCE  
Branch CAG II New Delhi Account no 39922687394 IFSC SBIN0017313  
(Bhel Pem Noida)

**Splitting/विभाजन**

Bid splitting not applied/बोली विभाजन लागू नहीं किया गया.

**Reserved for Make In India products**

Reserved for Make In India products	Yes
-------------------------------------	-----

**MSE Purchase Preference/एमएसई खरीद वरीयता**

MSE Purchase Preference/एमएसई खरीद वरीयता	Yes
---	-----

1. Bid reserved for Make In India products: : Procurement under this bid is reserved for purchase from Class 1 local supplier as defined in public procurement (Preference to Make in India), Order 2017 as amended from time to time and its subsequent Orders/Notifications issued by concerned Nodal Ministry for specific Goods/Products. However, eligible micro and small enterprises will be allowed to participate. The minimum local content to qualify as a class 1 local supplier is denoted in the bid document. All bidders must upload a certificate from the OEM regarding the percentage of the local content and the details of locations at which the local value addition is made along with their bid, failing which the bid is liable to be rejected. In case the bid value is more than Rs 10 Crore, the declaration relating to percentage of local content shall be certified by the statutory auditor or cost auditor, if the OEM is a company and by a practicing cost accountant or a chartered accountant for OEMs other than companies as per the Public Procurement (preference to Make-in -India) order 2017 dated 04.06.2020 . In case Buyer has selected Purchase preference to Micro and Small Enterprises clause in the bid, the same will get precedence over this clause.

2. Purchase preference to Micro and Small Enterprises (MSEs): Purchase preference will be given to MSEs as defined in Public Procurement Policy for Micro and Small Enterprises (MSEs) Order, 2012 dated 23.03.2012 issued by Ministry of Micro, Small and Medium Enterprises and its subsequent Orders/Notifications issued by concerned Ministry. If the bidder wants to avail the Purchase preference, the bidder must be the manufacturer of the offered product in case of bid for supply of goods. Traders are excluded from the purview of Public Procurement Policy for Micro and Small Enterprises. In respect of bid for Services, the bidder must be the Service provider of the offered Service. Relevant documentary evidence in this regard shall be uploaded along with the bid in respect of the offered product or service. If L-1 is not an MSE and MSE Seller (s) has/have quoted price within L-1+ 15% (Selected by Buyer) of margin of purchase preference /price band defined in relevant policy, such Seller shall be given opportunity to match L-1 price and contract will be awarded for 25%(selected by Buyer) percentage of total QUANTITY. The buyers are advised to refer the OM No.F.1/4/2021-PPD dated 18.05.2023

[OM No.1 4 2021 PPD dated 18.05.2023](#) for compliance of Concurrent application of Public Procurement Policy for Micro and Small Enterprises Order, 2012 and Public Procurement (Preference to Make in India) Order, 2017.

3. Estimated Bid Value indicated above is being declared solely for the purpose of guidance on EMD amount and for determining the Eligibility Criteria related to Turn Over, Past Performance and Project / Past Experience etc. This has no relevance or bearing on the price to be quoted by the bidders and is also not going to have any impact on bid participation. Also this is not going to be used as a criteria in determining reasonableness of quoted prices which would be determined by the buyer based on its own assessment of reasonableness and based on competitive prices received in Bid / RA process.

4. Reverse Auction would be conducted amongst all the technically qualified bidders except the Highest quoting bidder. The technically qualified Highest Quoting bidder will not be allowed to participate in RA. However, H-1 will also be allowed to participate in RA in following cases:

- i. If number of technically qualified bidders are only 2 or 3.
- ii. If Buyer has chosen to split the bid amongst N sellers, and H1 bid is coming within N.
- iii. In case Primary product of only one OEM is left in contention for participation in RA on elimination of H-1.
- iv. If L-1 is non-MSE and H-1 is eligible MSE and H-1 price is coming within price band of 15% of Non-MSE L-1
- v. If L-1 is non-MII and H-1 is eligible MII and H-1 price is coming within price band of 20% of Non-MII L-1

## **FLEXIBLE COPPER BRAID FOR GATE EARHTING**

**(Minimum 60% Local Content required for qualifying as Class 1 Local Supplier)**

### **Technical Specifications/तकनीकी विशिष्टियाँ**

<b>Specification Document</b>	<a href="#">View File</a>
<b>BOQ Detail Document</b>	<a href="#">View File</a>

Advisory-Please refer attached BOQ document for detailed consignee list and delivery period.

**Consignees/Reporting Officer/परेषिती/रिपोर्टिंग अधिकारी and/ तथा Quantity/मात्र**

S.No./क्र. सं.	Consignee Reporting/Officer/ परेषिती/रिपोर्टिंग अधिकारी	Address/पता	Quantity/मात्र	Delivery Days/डिलीवरी के दिन
1	Kavila Mohan Prabhakar	508001,Construction Manager, BHARAT HEAVY ELECTRICALS LIMITED, Site Office, 5 X 800MW YADADRI TPS (EPC), VEERLAPALEM, DAMARACHARLA MANDAL, NALGONDA, TELNGANA-508001	36	240

**GS FLAT 50 X 6 MM****(Minimum 60% Local Content required for qualifying as Class 1 Local Supplier)****Technical Specifications/तकनीकी विशिष्टियाँ**

<b>Specification Document</b>	<a href="#">View File</a>
<b>BOQ Detail Document</b>	<a href="#">View File</a>

Advisory-Please refer attached BOQ document for detailed consignee list and delivery period.

**Consignees/Reporting Officer/परेषिती/रिपोर्टिंग अधिकारी and/ तथा Quantity/मात्र**

S.No./क्र. सं.	Consignee Reporting/Officer/ परेषिती/रिपोर्टिंग अधिकारी	Address/पता	Quantity/मात्र	Delivery Days/डिलीवरी के दिन
1	Kavila Mohan Prabhakar	508001,Construction Manager, BHARAT HEAVY ELECTRICALS LIMITED, Site Office, 5 X 800MW YADADRI TPS (EPC), VEERLAPALEM, DAMARACHARLA MANDAL, NALGONDA, TELNGANA-508001	135	240

## GS FLAT 75 X 10 MM

(Minimum 60% Local Content required for qualifying as Class 1 Local Supplier)

Technical Specifications/तकनीकी विशिष्टियाँ

<b>Specification Document</b>	<a href="#">View File</a>
<b>BOQ Detail Document</b>	<a href="#">View File</a>

Advisory-Please refer attached BOQ document for detailed consignee list and delivery period.

Consignees/Reporting Officer/परेषिती/रिपोर्टिंग अधिकारी and/ तथा Quantity/मात्रा

S.No./क्र. सं.	Consignee Reporting/Officer/ परेषिती/रिपोर्टिंग अधिकारी	Address/पता	Quantity/मात्रा	Delivery Days/डिलीवरी के दिन
1	Kavila Mohan Prabhakar	508001, Construction Manager, BHARAT HEAVY ELECTRICALS LIMITED, Site Office, 5 X 800MW YADADRI TPS (EPC), VEERLAPALEM, DAMARACHARLA MANDAL, NALGONDA, TELNGANA-508001	313	240

## HOT DIP GALVANISED MS SHEET 14 SWG

(Minimum 60% Local Content required for qualifying as Class 1 Local Supplier)

Technical Specifications/तकनीकी विशिष्टियाँ

<b>Specification Document</b>	<a href="#">View File</a>
<b>BOQ Detail Document</b>	<a href="#">View File</a>

Advisory-Please refer attached BOQ document for detailed consignee list and delivery period.

**Consignees/Reporting Officer/परेषिती/रिपोर्टिंग अधिकारी and/ तथा Quantity/मात्र**

S.No./क्र. सं.	Consignee Reporting/Officer/ परेषिती/रिपोर्टिंग अधिकारी	Address/पता	Quantity/मात्र	Delivery Days/डिलीवरी के दिन
1	Kavila Mohan Prabhakar	508001,Construction Manager, BHARAT HEAVY ELECTRICALS LIMITED, Site Office, 5 X 800MW YADADRI TPS (EPC), VEERLAPALEM, DAMARACHARLA MANDAL, NALGONDA, TELNGANA-508001	180	240

**TEST LINK 150X75X10 MM GS FLAT WITH BOX****(Minimum 60% Local Content required for qualifying as Class 1 Local Supplier)****Technical Specifications/तकनीकी विशिष्टियाँ**

<b>Specification Document</b>	<a href="#">View File</a>
<b>BOQ Detail Document</b>	<a href="#">View File</a>

Advisory-Please refer attached BOQ document for detailed consignee list and delivery period.

**Consignees/Reporting Officer/परेषिती/रिपोर्टिंग अधिकारी and/ तथा Quantity/मात्र**

S.No./क्र. सं.	Consignee Reporting/Officer/ परेषिती/रिपोर्टिंग अधिकारी	Address/पता	Quantity/मात्र	Delivery Days/डिलीवरी के दिन
1	Kavila Mohan Prabhakar	508001,Construction Manager, BHARAT HEAVY ELECTRICALS LIMITED, Site Office, 5 X 800MW YADADRI TPS (EPC), VEERLAPALEM, DAMARACHARLA MANDAL, NALGONDA, TELNGANA-508001	508	240

**GI WIRE 16 SWG****(Minimum 60% Local Content required for qualifying as Class 1 Local Supplier)**

## Technical Specifications/तकनीकी विशिष्टियाँ

<b>Specification Document</b>	<a href="#">View File</a>
<b>BOQ Detail Document</b>	<a href="#">View File</a>

Advisory-Please refer attached BOQ document for detailed consignee list and delivery period.

## Consignees/Reporting Officer/परेषिती/रिपोर्टिंग अधिकारी and/ तथा Quantity/मात्रा

S.No./क्र. सं.	Consignee Reporting/Officer/ परेषिती/रिपोर्टिंग अधिकारी	Address/पता	Quantity/मात्रा	Delivery Days/डिलीवरी के दिन
1	Kavila Mohan Prabhakar	508001,Construction Manager, BHARAT HEAVY ELECTRICALS LIMITED, Site Office, 5 X 800MW YADADRI TPS (EPC), VEERLAPALEM, DAMARACHARLA MANDAL, NALGONDA, TELNGANA-508001	530000	240

## Buyer Added Bid Specific Terms and Conditions/क्रेता द्वारा जोड़ी गई बिड की विशेष शर्तें

### 1. Generic

OPTION CLAUSE: The Purchaser reserves the right to increase or decrease the quantity to be ordered up to 25 percent of bid quantity at the time of placement of contract. The purchaser also reserves the right to increase the ordered quantity by up to 25% of the contracted quantity during the currency of the contract at the contracted rates. Bidders are bound to accept the orders accordingly.

### 2. Certificates

Bidder's offer is liable to be rejected if they don't upload any of the certificates / documents sought in the Bid document, ATC and Corrigendum if any.

### 3. Generic

Bidders are advised to check applicable GST on their own before quoting. Buyer will not take any responsibility in this regards. GST reimbursement will be as per actuals or as per applicable rates (whichever is lower), subject to the maximum of quoted GST %.

### 4. Buyer Added Bid Specific ATC

Buyer uploaded ATC document [Click here to view the file.](#)

## 5. Purchase Preference (Centre)

Purchase preference to Micro and Small Enterprises (MSEs): Purchase preference will be given to MSEs as defined in Public Procurement Policy for Micro and Small Enterprises (MSEs) Order, 2012 dated 23.03.2012 issued by Ministry of Micro, Small and Medium Enterprises and its subsequent Orders/Notifications issued by concerned Ministry. If the bidder wants to avail the Purchase preference, the bidder must be the manufacturer of the offered product in case of bid for supply of goods. Traders are excluded from the purview of Public Procurement Policy for Micro and Small Enterprises. In respect of bid for Services, the bidder must be the Service provider of the offered Service. Relevant documentary evidence in this regard shall be uploaded along with the bid in respect of the offered product or service. If L-1 is not an MSE and MSE Seller (s) has/have quoted price within L-1+ 15% of margin of purchase preference /price band defined in relevant policy, such Seller shall be given opportunity to match L-1 price and contract will be awarded for percentage of 25% of total value.

## 6. Scope of Supply

Scope of supply (Bid price to include all cost components) : Only supply of Goods

## 7. Generic

While generating invoice in GeM portal, the seller must upload scanned copy of GST invoice and the screenshot of GST portal confirming payment of GST.

## 8. Inspection

**Nominated Inspection Agency:** On behalf of the Buyer organization, any one of the following Inspection Agency would be conducting inspection of stores before acceptance:  
Pre-dispatch Inspection at Seller Premises (applicable only if pre-dispatch inspection clause has been selected in ATC):

BHEL NOMINATED TPIA

Post Receipt Inspection at consignee site before acceptance of stores:  
NA

## 9. Certificates

The bidder is required to upload, along with the bid, all relevant certificates such as BIS licence, type test certificate, approval certificates and other certificates as prescribed in the Product Specification given in the bid document.

## Disclaimer/अस्वीकरण

The additional terms and conditions have been incorporated by the Buyer after approval of the Competent Authority in Buyer Organization, whereby Buyer organization is solely responsible for the impact of these clauses on the bidding process, its outcome, and consequences thereof including any eccentricity / restriction arising in the bidding process due to these ATCs and due to modification of technical specifications and / or terms and conditions governing the bid. Any clause(s) incorporated by the Buyer regarding following shall be treated as null and void and would not be considered as part of bid:-

1. Definition of Class I and Class II suppliers in the bid not in line with the extant Order / Office Memorandum issued by DPIIT in this regard.
2. Seeking EMD submission from bidder(s), including via Additional Terms & Conditions, in contravention to exemption provided to such sellers under GeM GTC.
3. Publishing Custom / BOQ bids for items for which regular GeM categories are available without any Category item bunched with it.
4. Creating BoQ bid for single item.
5. Mentioning specific Brand or Make or Model or Manufacturer or Dealer name.
6. Mandating submission of documents in physical form as a pre-requisite to qualify bidders.

7. Floating / creation of work contracts as Custom Bids in Services.
8. Seeking sample with bid or approval of samples during bid evaluation process.
9. Mandating foreign / international certifications even in case of existence of Indian Standards without specifying equivalent Indian Certification / standards.
10. Seeking experience from specific organization / department / institute only or from foreign / export experience.
11. Creating bid for items from irrelevant categories.
12. Incorporating any clause against the MSME policy and Preference to Make in India Policy.
13. Reference of conditions published on any external site or reference to external documents/clauses.
14. Asking for any Tender fee / Bid Participation fee / Auction fee in case of Bids / Forward Auction, as the case may be.

Further, if any seller has any objection/grievance against these additional clauses or otherwise on any aspect of this bid, they can raise their representation against the same by using the Representation window provided in the bid details field in Seller dashboard after logging in as a seller within 4 days of bid publication on GeM. Buyer is duty bound to reply to all such representations and would not be allowed to open bids if he fails to reply to such representations.

[This Bid is also governed by the General Terms and Conditions/ यह बिड सामान्य शर्तों के अंतर्गत भी शासित है](#)

In terms of GeM GTC clause 26 regarding Restrictions on procurement from a bidder of a country which shares a land border with India, any bidder from a country which shares a land border with India will be eligible to bid in this tender only if the bidder is registered with the Competent Authority. While participating in bid, Bidder has to undertake compliance of this and any false declaration and non-compliance of this would be a ground for immediate termination of the contract and further legal action in accordance with the laws./जेम की सामान्य शर्तों के खंड 26 के संदर्भ में भारत के साथ भूमि सीमा साझा करने वाले देश के बिडर से खरीद पर प्रतिबंध के संबंध में भारत के साथ भूमि सीमा साझा करने वाले देश का कोई भी बिडर इस निविदा में बिड देने के लिए तभी पात्र होगा जब वह बिड देने वाला सक्षम प्राधिकारी के पास पंजीकृत हो।बिड में भाग लेते समय बिडर को इसका अनुपालन करना होगा और कोई भी गलत घोषणा किए जाने व इसका अनुपालन न करने पर अनुबंध को तत्काल समाप्त करने और कानून के अनुसार आगे की कानूनी कार्रवाई का आधार होगा।

**---Thank You/धन्यवाद---**

**TECHNICAL SPECIFICATION**  
**FOR**  
***ABOVE GROUND EARTHING***  
**&**  
***LIGHTNING PROTECTION MATERIALS***

**SPECIFICATION NO.: *PE-TS-417-509-E003***

***REVISION: 00***



**BHARAT HEAVY ELECTRICALS LIMITED**  
**POWER SECTOR**  
**PROJECT ENGINEERING MANAGEMENT**  
**NOIDA, UP (INDIA) – 201301**

	<b>TECHNICAL SPECIFICATION FOR ABOVE GROUND EARTHING &amp; LIGHTNING PROTECTION MATERIALS</b>	SPECIFICATION NO. PE-TS-417-509-E003
		VOLUME NO.: II-B
		SECTION: I
		REV NO.: 00 DATE: 27.07.2023
		SHEET : 1 OF 1

**CONTENTS**

S. NO	DESCRIPTION	NO. OF SHEETS
1	COMPLIANCE SHEET	01
2	SECTION - 'I' (SCOPE OF ENQUIRY)	02
3	SECTION - 'II' (STANDARD TECHNICAL REQUIREMENTS) (QUALITY PLAN) + ANNEXURE 1	03 05
	ANNEXURE – A (APPLICABLE STANDARDS & CODES)	01
	TECHNICAL DATA SHEET	01
4	ANNEXURE-B (PRICE VARIATION FORMULAE)	01

	<b>TECHNICAL SPECIFICATION FOR ABOVE GROUND EARTHING &amp; LIGHTNING PROTECTION MATERIALS</b>	SPECIFICATION NO. PE-TS-417-509-E003
		VOLUME NO.: II-B
		SECTION: I
		REV NO.: 00 DATE: 27.07.2023
		SHEET : 1 OF 3

### COMPLIANCE CERTIFICATE

The bidder shall confirm compliance to the following by signing/ stamping this compliance certificate and furnishing same with the offer.

1. The scope of supply, technical details, construction features, design parameters etc. shall be as per technical specification & there are no exclusion/ deviation with regard to same
2. There are no deviations with respect to specification other than those furnished in the 'schedule of deviations'
3. Only those technical submittals which are specifically asked for in NIT to be submitted at tender stage shall be considered as part of offer. Any other submission, even if made, shall not be considered as part of offer.
4. Any comments/ clarifications on technical/ inspection requirements furnished as part of bidder's covering letter shall not be considered by BHEL, and bidder's offer shall be construed to be in conformance with the specification.
5. Any changes made by the bidder in the price schedule with respect to the description/ quantities from those given in 'BOQ-Cum-Price schedule' of the specification shall not be considered (i.e., technical description & quantities as per the specification shall prevail).

-----  
BIDDER'S STAMP & SIGNATURE

	<b>TECHNICAL SPECIFICATION FOR ABOVE GROUND EARTHING &amp; LIGHTNING PROTECTION MATERIALS</b>	SPECIFICATION NO. PE-TS-417-509-E003
		VOLUME NO.: II-B
		SECTION: I
		REV NO.: 00 DATE: 27.07.2023
		SHEET : 2 OF 3

### SCOPE OF ENQUIRY

#### 1.0 SCOPE

This specification covers the Design, Manufacture, Inspection and Testing at Manufacturer's works, proper packing and delivery to site of **ABOVE GROUND EARTHING & LIGHTNING PROTECTION MATERIALS**.

- 2.0 The bids shall be evaluated as per NIT.
- 3.0 The bidder shall be responsible for and governed by all requirements stipulated hereinafter.
- 4.0 Bidder shall confirm total compliance to the specification without any deviations from technical/quality assurance requirements stipulated.
- 5.0 The documents shall be in English Language and MKS system of units.
- 6.0 The quality plan enclosed forms the minimum requirement but not limited to be adhered by the bidder.

#### 7.0 GENERAL TECHNICAL INSTRUCTIONS

- i) BHEL's / Customer representatives shall be given access to the shop in which the Above Ground Earthing & Lightning Protection materials are being manufactured or tested and all test records shall be made available to them.
- ii) The material covered under this specification shall not be dispatched unless the same have been finally inspected, accepted and Material Dispatch Clearance Certificate (MDCC) is issued by BHEL / Customer.
- iii) The bidder to quote for items as per price schedule attached with NIT.
- iv) After issuance of purchase order, the successful bidder shall submit the QP for BHEL/ end customer's approval. In case bidder has reference QP agreed with end customer, same can be submitted after issuance of purchase order for BHEL/ end customer's approval. There shall be no commercial implication to BHEL on account of QP approval. Inspection shall be carried out in line with QP approved for the project.
- v) Inspection will be conducted by BHEL and/or their authorized representatives as per the inspection schedule agreed for the project. The inspection schedule will be submitted by the bidder for BHEL's approval. The cost of all tests and inspections will be deemed to have been included in the contract.
- vi) Refer Section-II for detailed technical specification, Code & Standards, Tests & Inspection, Drawings & Documents, and Packing.



**TECHNICAL SPECIFICATION FOR  
ABOVE GROUND EARTHING &  
LIGHTNING PROTECTION  
MATERIALS**

SPECIFICATION NO. PE-TS-417-509-E003

VOLUME NO.: II-B

SECTION: I

REV NO.: 00 DATE: 27.07.2023

SHEET : 3 OF 3

**9.0 SPECIFIC TECHNICAL REQUIREMENTS**

<b><u>S.No.</u></b>	<b><i>Reference Clause No. of Section- II</i></b>	<b><i>Specific Requirement/ Change</i></b>
1.	Clause 4.4	Test Link with box shall be applicable
2.	Clause 4.6	Not applicable

	<b>TECHNICAL SPECIFICATION FOR ABOVE GROUND EARTHING &amp; LIGHTNING PROTECTION MATERIALS</b>	SPECIFICATION NO. PE-TS-417-509-E003
		VOLUME NO.: II-B
		SECTION: II
		REV NO.: 00 DATE: 27.07.2023
		SHEET : 1 OF 3

### STANDARD TECHNICAL REQUIREMENTS

#### 1.0 INTENT OF SPECIFICATION

- 1.1 This specification covers the design, manufacture, inspection & testing, packing at manufacturer's works and delivery to site of Above **Ground Earthing & Lightning Protection materials**.
- 1.2 The intent of specification is not to specify all details of design & construction of material. The material shall, however, conform in all aspects to high standard of design, engineering and workmanship and be capable of performing in continuous operation up to & after bidder's guarantee period in manner acceptable to purchaser who will interpret the drawings & specification and shall have power to reject any work or material which in his judgement is not in full accordance with this specification.

#### 2.0 CODES AND STANDARDS

- 2.1 The material shall comply with all currently applicable safety codes and statutory regulations of India as well as of the locality where the material is to be installed.
- 2.2 The design, material, construction, manufacture, inspection, testing and performance of **Above Ground Earthing & Lightning Protection materials** shall conform to the latest revision of relevant standards and codes of practices as per Annexure-A.
- 2.3 **In case of conflict between the applicable reference standard and this specification, this specification shall govern.**

#### 3.0 SCOPE OF ENQUIRY

- 3.1 Bidder shall quote for **Above Ground Earthing & Lightning Protection materials** in accordance with various sections of this specification. The system shall be complete in all aspects, for satisfactory operation, in accordance with this specification & technical particular.

#### 4.0 TECHNICAL REQUIREMENTS

- 4.1 Technical particulars of Above Ground Earthing & Lightning Protection materials are specified in Technical Datasheet.
- 4.2 Straight lengths of hot dip galvanised MS materials as per project specific requirement shall be supplied in standard lengths as below:
- |    |                              |   |                      |
|----|------------------------------|---|----------------------|
| a) | MS Flats of all sizes        | : | 4-7 metres           |
| b) | SWG wires of different sizes | : | 100 metres (minimum) |

	<b>TECHNICAL SPECIFICATION FOR ABOVE GROUND EARTHING &amp; LIGHTNING PROTECTION MATERIALS</b>	SPECIFICATION NO. PE-TS-417-509-E003
		VOLUME NO.: II-B
		SECTION: II
		REV NO.: 00 DATE: 27.07.2023
		SHEET : 2 OF 3

- 4.3 All finished galvanized MS material shall be free from sharp edges, corners, burs & unevenness.
- 4.4 Test link without box & Test link with box shall be as per enclosed drawing no. PE-DG-417-509-E004.
- 4.5 Flexible braided Copper Conductor of 600 mm length (cross section equivalent to 300 sq.mm) with tinned copper clamp connected by U-bolt for fence gate earthing shall be as per enclosed drawing no. PE-DG-999-509-E003.
- 4.6 Shielding Mast shall be as per enclosed drawing no. PE-DG-999-509-E003.
- 4.7 Necessary fixing hardware shall be provided along with each accessory as specified in drawings enclosed.

#### **5.0 QUALITY ASSURANCE, TESTING & INSPECTION**

- 5.1 BHEL's Standard QP (PE-QP-999-509-E001) enclosed forms the minimum requirement but not limited to be adhered by the bidder. After issuance of purchase order, the successful bidder shall submit the QP for BHEL/ end customer's approval. In case bidder has reference QP agreed with end customer, same can be submitted after issuance of purchase order for BHEL/ end customer's approval. There shall be no commercial implication to BHEL on account of QP approval. Inspection shall be carried out in line with QP approved for the project.
- 5.2 All materials shall be procured, manufactured, inspected and tested by vendor/ sub-vendor as per quality plan approved for the project.
- 5.3 The supplier shall perform all tests necessary to ensure that the material and workmanship conform to the relevant standards and comply with the requirements of the specification. Charges for all these tests for all the equipment & components shall be deemed to be included in the bid price.

#### **6.0 PACKING**

- 6.1 The material shall be packed to ensure protection against damage during transit, storage for prolonged periods and handling.

#### **7.0 DRAWINGS & DOCUMENTS TO BE SUBMITTED**

- 7.1 Bidders shall furnish following documents as the part of their technical offer: -
- a) Signed copy of Compliance Sheet

	<b>TECHNICAL SPECIFICATION FOR ABOVE GROUND EARTHING &amp; LIGHTNING PROTECTION MATERIALS</b>	SPECIFICATION NO. PE-TS-417-509-E003
		VOLUME NO.: II-B
		SECTION: II
		REV NO.: 00 DATE: 27.07.2023
		SHEET : 3 OF 3

7.2 After issuance of purchase order, following information shall be furnished by BHEL: -

- a) Title Sheet
- b) Updated list of BHEL-PEM approved Galvanizers (Refer Annexure-2 to Quality Plan)

7.3 Following documents/drawings shall be submitted after placement of order for specific project for BHEL & customer's approval: -

Sl. No.	Drawings/Document Description	Drawings / Document Number	Submission Schedule
1.	Quality Plan for Above ground earthing & Lightning protection material.	PE-V0-417-507-E903	As per attached delivery Schedule

7.4 Documents shall be submitted through document management system (DMS).

	<b>TECHNICAL SPECIFICATION FOR ABOVE GROUND EARTHING &amp; LIGHTNING PROTECTION MATERIALS</b>	SPECIFICATION NO. PE-TS-417-509-E003
		VOLUME NO.: II-B
		SECTION: II
		REV NO.: 00 DATE: 27.07.2023
		SHEET : 1 OF 1

ANNEXURE - A

APPLICABLE STANDARDS & CODES

For Hot rolled carbon sheets & strips.	IS: 2062
For Mild Steel Wire	IS: 280
For Surface pre treatment	IS: 2629
For Hot dip galvanising of steel	IS: 2629
For Hot dipped galvanised coating on round steel wires	IS: 4826
For Testing of zinc coating	IS: 2633
For Determining of mass of zinc coating	IS: 6745
For Rolling & cutting tolerances of hot rolled steel products	IS: 1852
For Hot dip zinc coating on structural steel & other allied products	IS: 4759
For Tubes, Tubulars and other Wrought Steel Fittings	IS: 1239

	<b>TECHNICAL SPECIFICATION FOR ABOVE GROUND EARTHING &amp; LIGHTNING PROTECTION MATERIALS</b>	SPECIFICATION NO. PE-TS-417-509-E003
		VOLUME NO.: II-B
		SECTION: II
		REV NO.: 00 DATE: 27.07.2023
		SHEET : 1 OF 1

### TECHNICAL DATASHEET

#### **1.0 GALVANIZED MS MATERIALS FOR ABOVE GROUND EARTHING AND LIGHTNING PROTECTION SYSTEMS**

- a) Material: Hot Rolled Mild Steel
- b) Type: Hot-dip galvanized

#### **2.0 SURFACE TREATMENT**

Galvanising:

- a) Pre-treatment As per IS 2629 prior to galvanization
- b) Type Hot dip galvanization.
- c) Applicable Standard IS 2629
- d) Minimum thickness:
- |  |                            |
|--|----------------------------|
| i) MS flats 5mm thick & over                     | 75 microns (minimum)       |
| ii) MS flats under 5mm thickness                 | 60 microns (minimum)       |
| iii) Pipes/ conduits with thickness 5 mm & over. | 75 microns (minimum)       |
| iv) Pipes/ conduits with thickness under 5mm     | 60 microns (minimum)       |
| v) GI Wire                                       | 20 Microns (Medium coated) |
- e) Min. weight:
- |  |                     |
|--|---------------------|
| i) MS flats 5mm thick & over                     | 610 gms. / sq. mtr. |
| ii) MS flats under 5mm thickness                 | 460 gms. / sq. mtr. |
| iii) Pipes/ conduits with thickness 5 mm & over. | 610 gms. / sq. mtr  |
| iv) Pipes/ conduits with thickness under 5mm.    | 460 gms. / sq. mtr  |
| v) GI Wire                                       | 150 gms. / sq. mtr. |

	<b>MANUFACTURER/ BIDDER:-</b>	<b>QUALITY PLAN</b>					<b>SPEC. NO :- PE-TS-417-509-E003</b>			<b>DATE:-27.07.23</b>			
		<b>CUSTOMER : M/s TSGENCO</b>					<b>QP NO.:PE-V0-417-507-E903</b>			<b>DATE:</b>			
		<b>PROJECT:- 5X800 MW YADADRI TPS</b>					<b>PO NO.:-</b>						
		<b>ITEM: ABOVE GROUND EARTHING MATERIALS</b>					<b>SYSTEM:EARTHING</b>			<b>Inspection Category: II</b>			<b>SHEET 1 OF 4</b>

Sl. No.	COMPONENT S & OPERATIONS	CHARACTERISTICS	CLAS S	TYPE OF CHECK	QUANTUM OF CHECK		REFERENCE DOCUMENT	ACCEPTANCE NORMS	FORMAT OF RECORD		AGENCY			REMARKS
1	2	3	4	5	6		7	8	9	*	**			
					M	C/N				D	M	C	N	

**1.0 RAW MATERIAL:**

1.1	MILD STEEL (FLATS & RODS) AS PER SPECIFICATION	1. CHEMICAL & PHYSICAL PROPERTIES	MA	VERIFICATION OF TC'S	100%	100%	IS 2062	IS 2062	MILL TC	✓	P	V	V	REFER REMARKS AT SL. NO. 1
		2.DIMENSION	MA	MEASUREMENT	100%	100%	IS 1730	IS 1730	QC RECORD	✓	P	V	V	
		3.SURFACE FINISH	MA	VISUAL	100%	100%	IS 1079	IS 1079	QC RECORD	✓	P	V	V	
1.2	ZINC	1.CHEMICAL COMP.	MA	CHEM. TEST	SAMPLE	SAMP LE	IS 209	IS 209	QC RECORD	✓	P	V	V	

**2.0 IN PROCESS:**

2.1	CUTTING, DRILLING	1.DIMENSIONS	MA	MEASUREMENT	100%	100%	APPROVED DATA SHEET / DRAWING	APPROVED DATA SHEET / DRAWING	QC RECORD	✓	P	V	V	
		2. SURFACE FINISH	MA	VISUAL	100%	100%	-	FREE FROM DEFECTS/ SLAG	TEST/ INSPN. REPORT	✓	P	V	V	
2.2	SURFACE PREPARATION	1. CLEANING, PICKLING, RINSING & FLUXING	MA	VISUAL	100%	100%	IS 2629	IS 2629	QC RECORD	✓	P	V	V	
		2. SURFACE FINISH	MA	VISUAL	100%	100%	IS 2629	IS 2629	QC RECORD	✓	P	V	V	
2.3	GALVANISING	1.TEMPERATURE OF BATH	MA	MEASUREMENT	CONTINUOUS	CONTINUOUS	IS 2629	IS 2629	QC RECORD	✓	P	V	V	Galvanization is to be done at galvanization plant listed in annexure-1 to quality plan.
		2. DROSS	MA	VISUAL	PERIODIC	PERIODIC	IS 2629	IS 2629	QC RECORD	✓	P	V	-	

SUPPLIER			BHEL			FOR CUSTOMER REVIEW & APPROVAL		
QUALITY ASSURANCE			QUALITY			Doc No:		
Sign & Date	Name		Sign & Date	Name		Sign & Date		Name
Prepared by:			Reviewed by:			Approved by:		

MANUFACTURER/ BIDDER:-	QUALITY PLAN					SPEC. NO :- PE-TS-417-509-E003			DATE:-27.07.23		
	CUSTOMER : M/s TSGENCO					QP NO.:PE-V0-417-507-E903			DATE:		
	PROJECT:- 5X800 MW YADADRI TPS					PO NO.:-					
	ITEM: ABOVE GROUND EARTHING MATERIALS					SYSTEM:EARTHING			Inspection Category: II		

Sl. No.	COMPONENTS & OPERATIONS	CHARACTERISTICS	CLASS	TYPE OF CHECK	QUANTUM OF CHECK		REFERENCE DOCUMENT	ACCEPTANCE NORMS	FORMAT OF RECORD		AGENCY			REMARKS
1	2	3	4	5	6		7	8	9	*	**			
					M	C/N				D	M	C	N	

		3.RATE OF IMMERSION	MA	VISUAL/ MEASUREMENT	100%	100%	IS 2629	IS 2629	QC RECORD	✓	P	V	-													
		4. SURFACE FINISH	MA	VISUAL	100%	100%	IS 2629	FREE FROM BURRS, ROUGHNESS, SLAG, FLUX, STAIN	QC RECORD	✓	P	V	-													
3.0	FINISHED ITEMS:																									
3.1	MS FLATS	1. CHEMICAL COMP.	MA	CHEM. TEST	1 No./LOT/SIZE	1 No./LOT/SIZE	IS 2026	IS 2026	LAB TC	✓	P	V	V	Note: sample for chemical test shall be selected by BHEL& testing shall be done at NABL/ govt. approved Lab.  Sampling plan for galvanization test: Inspection shall be as per table 2 of IS 4759 and same is mentioned below:-												
		2. DIMENSIONS	MA	MEASUREMENT	IS 2500 (PART 1) LEVEL S-4	IS 2500 (PART 1) LEVEL S-4	APPROVED DATA SHEET / DRAWING	APPROVED DATA SHEET / DRAWING	INSPECTION REPORT	✓	P	W	V	<table border="1"> <thead> <tr> <th>No. of units in a Lot</th> <th>No. of units to be selected in a sample</th> <th>Acceptance No.</th> </tr> </thead> <tbody> <tr> <td>(1)</td> <td>(2)</td> <td>(3)</td> </tr> <tr> <td>Upto 25</td> <td>3</td> <td>0</td> </tr> <tr> <td>26-100</td> <td>5</td> <td>0</td> </tr> </tbody> </table>	No. of units in a Lot	No. of units to be selected in a sample	Acceptance No.	(1)	(2)	(3)	Upto 25	3	0	26-100	5	0
No. of units in a Lot	No. of units to be selected in a sample	Acceptance No.																								
(1)	(2)	(3)																								
Upto 25	3	0																								
26-100	5	0																								
		3. SURFACE FINISH	MA	VISUAL	IS 2500 (PART 1) LEVEL S-4	IS 2500 (PART 1) LEVEL S-4	-	FREE FROM BURRS, ROUGHNESS, SLAG, FLUX, STAIN ETC.	QC RECORD	✓	P	W	V													

SUPPLIER			BHEL			FOR CUSTOMER REVIEW & APPROVAL		
QUALITY ASSURANCE			QUALITY			Doc No:		
	Sign & Date	Name		Sign & Date	Name		Sign & Date	Name
Prepared by:			Reviewed by:			Approved by:		

MANUFACTURER/ BIDDER:-	QUALITY PLAN						SPEC. NO :- PE-TS-417-509-E003	DATE:-27.07.23
	CUSTOMER : M/s TSGENCO						QP NO.:PE-V0-417-507-E903	DATE:
	PROJECT:- 5X800 MW YADADRI TPS						PO NO.:-	
	ITEM: ABOVE GROUND EARTHING MATERIALS			SYSTEM:EARTHING			Inspection Category: II	SHEET 3 OF 4

Sl. No.	COMPONENT S & OPERATIONS	CHARACTERISTICS	CLASS	TYPE OF CHECK	QUANTUM OF CHECK		REFERENCE DOCUMENT	ACCEPTANCE NORMS	FORMAT OF RECORD		AGENCY			REMARKS
1	2	3	4	5	6		7	8	9	*	**			
					M	C/N				D	M	C	N	

		4.MASS OF ZINC COATING	MA	CHEM. TEST	REFER REMARKS	REFER REMARKS	IS-6745 /APP. DATA SHEET	APP. DATA SHEET	INSP. REPORT	✓	P	W	V	<table border="1"> <tr><td>101-150</td><td>8</td><td>1</td></tr> <tr><td>151-500</td><td>13</td><td>1</td></tr> <tr><td>501-1000</td><td>20</td><td>2</td></tr> <tr><td>1001-10000</td><td>32</td><td>3</td></tr> <tr><td>10001 and above</td><td>50</td><td>5</td></tr> </table>	101-150	8	1	151-500	13	1	501-1000	20	2	1001-10000	32	3	10001 and above	50	5
101-150	8	1																											
151-500	13	1																											
501-1000	20	2																											
1001-10000	32	3																											
10001 and above	50	5																											
		5.UNIFORMITY OF ZINC COATING	MA	CHEM. TEST	IS-4759	IS-4759	IS-2633	IS-2633	INSP. REPORT	✓	P	W	V	Note:- If the number of defective units in a lot exceeds the acceptance number as specified in col (3) of the table, the lot shall be rejected, else accepted.															
		6. THICKNESS OF ZINC COATING	MA	MEASUREMENT	IS-4759	IS-4759	APP. DATA SHEET	APP. DATA SHEET	INSP. REPORT	✓	P	W	V																
		7. ADHESION	MA	MECH. TEST	IS-4759	IS-4759	IS 2629	IS 2629	INSP. REPORT	✓	P	W	V																

Note: Items like Pipes/ Flexible Copper Braid/ GI wire/ GS Rod/ Shielding Mast/ Test link will be cleared based on COC (certificate of Compliance)

4.0	PACKING	COMPLETENESS	MA	VISUAL	100%	100%	AS PER MFG. STANDARD / (#)	AS PER MFG. STANDARD / (#).	INSP. REPORT	✓	P	W	V	(#) REFER NOTE-4
-----	---------	--------------	----	--------	------	------	----------------------------	-----------------------------	--------------	---	---	---	---	------------------

NOTES:

- BHEL reserves the right to perform repeat test, if required.
- Material shall be packed suitably in order to avoid damage during transit and also during storage at site in tropical climate conditions. Packing shall be suitable for storage at site in tropical climate conditions.
- Latest revision/ year of issue of all the standards (IS/ASME/IEC etc.) indicated in QP shall be referred.
- Statutory requirements will be complied.

SUPPLIER			BHEL			FOR CUSTOMER REVIEW & APPROVAL		
QUALITY ASSURANCE			QUALITY			Doc No:		
Sign & Date	Name		Sign & Date	Name		Sign & Date		Name
Prepared by:			Reviewed by:			Approved by:		

MANUFACTURER/ BIDDER:-	QUALITY PLAN				SPEC. NO :- PE-TS-417-509-E003	DATE:-27.07.23
	CUSTOMER : M/s TSGENCO				QP NO.:PE-V0-417-507-E903	DATE:
	PROJECT:- 5X800 MW YADADRI TPS				PO NO.:-	
	ITEM: ABOVE GROUND EARTHING MATERIALS		SYSTEM:EARTHING		Inspection Category: II	SHEET 4 OF 4

Sl. No.	COMPONENT S & OPERATIONS	CHARACTERISTICS	CLASS	TYPE OF CHECK	QUANTUM OF CHECK	REFERENCE DOCUMENT	ACCEPTANCE NORMS	FORMAT OF RECORD	AGENCY	REMARKS
1	2	3	4	5	6	7	8	9	*	**
					M   C/N				D	M   C   N

5. Instruments used for test shall have valid calibration certificate with tractability to national level.
6. Bought out items shall be from approved vendor by TSGENCO/TCE for this project.
7. W at client column shall be considered as hold point
8. All inspection/verification/NDT reports along with material certificates shall be reviewed at the time of witness point

**LEGENDS:**

\*RECORDS, IDENTIFIED WITH "TICK"(√) SHALL BE ESSENTIALLY INCLUDED BY SUPPLIER IN QA DOCUMENTATION,  
 \*\* M: SUPPLIER/ MANUFACTURER/ SUB-SUPPLIER, C: MAIN SUPPLIER/ BHEL/ THIRD PARTY INSPECTION AGENCY, N: CUSTOMER,  
 P: PERFORM, W: WITNESS, V: VERIFICATION, AS APPROPRIATE  
 MA: MAJOR, MI: MINOR, CR: CRITICAL  
 D: DOCUMENTATION

SUPPLIER			BHEL			FOR CUSTOMER REVIEW & APPROVAL		
QUALITY ASSURANCE			QUALITY			Doc No:		
Sign & Date	Name		Sign & Date	Name		Sign & Date	Name	
Prepared by:			Reviewed by:			Approved by:		

## ANNEXURE-2 to Quality Plan

## (LIST OF BHEL- PEM APPROVED GALVANIZERS)

SL NO.	ITEM	VENDOR NAME	ADDRESS
1	GALVANISING	Jenco Industrial Corporation	Chincholi Bunder Khkar Road Near Link Road Devruwadi Malad (W) Mumbai 400064
2	GALVANISING	National Galvanizing Company	66, Barrackpore Kamarhatt Trunck Road Calcutta-700058
3	GALVANISING	Sigma Galvanising Pvt. Ltd.	Plot No.C-169, TTC, MIDC Ind Area Navin Mumbai-400705
4	GALVANISING	B.P. Projects PVT LTD	167A, Vivekananda Road Kolkata-700006
5	GALVANISING	Standard Galvanisers	Makardah Road, Kabar Para, Bankra, Howarah -711403
6	GALVANISING	Steel Products	National Highway No. 6, Chamrail, Kona, Howrah-711114
7	GALVANISING	Unitech Fabricators & Engineers Pvt. Ltd.	Village- Ajab Nagar, P.O. -Molla Simlla, P.S. - Singur, Dist - Hoogly, Pin-712223
8	GALVANISING	Shivam Engineers & Fabricators	A0-282-284, Industrial Area, South Side of G.T. Road, Ghaziabad, U.P.
9	GALVANISING	B.G. Shirke Construction Technology Pvt. Ltd	72-76, Mundhawa, Pune - 401 036
10	GALVANISING	Galbro Ispat Galvanizers Pvt. Ltd.	GUT 11 AND 12, OPP. Kudus Steel,Rolling Mill, Wada, Thane , Mumbai
11	GALVANISING	Eros Infrastructures Pvt. Ltd.	G-97, MIDC, Bhutibori , Nagpur-441108, Maharashtra
12	GALVANISING	Industrial Perforation (India) Pvt. Ltd.	Ganganagr, Katakhal, Kolkata-700132
13	GALVANISING	Indmark Formtech Pvt. Ltd.	Phase - 3, E - 11 / 1, M. I. D. C., Chakan, Pune - 410 501, Maharashtra, India.
14	GALVANISING	Namdhari Industrial Traders Pvt. Ltd.	Village Latton Dana, Chandigarh Road, Ludhiana
15	GALVANISING	Neha Galvaniser	Jalan Industrial Estate, Gate No-1, 1st Right Choise Lane, Near N.G-6, Jangalpur, PO Domjur Howrah - 700071, West Bengal, India
16	GALVANISING	Patny Systems (P) Ltd.	Unit-IV, Sy No. -228/9, Plot No. 6, IP Kuchavaram, Toopran(M) Dist.- Medak, Telegana - 502336
17	GALVANISING	Parmar Metal Company	Survey No.207,Veraval (Shapar) Dist. Rajkot, India.
18	GALVANISING	Rukmani Electrical & Components Pvt Ltd	Urla Industrial Area, Urla Sarora Road, Raipur- 493 221 (Chhattisgarh)
19	GALVANISING	Rukmani Fab & Gal Pvt Ltd	Shankharidaha Baniyarah, Jalan Industrial Complex, Gate no.3, Lane no. 4, Domjur, Howrah , W.B .- 711411
19	GALVANISING	DMP Projects Pvt.Ltd.	Dulagarh Industrial Park , PS-Sankrail , Howrah -711302
20	GALVANISING	Vinfab Engineers India Private Limited	Gut no. 224/1 &2 Bhiwandi Wada State Highway, Village khupri, Dist. Thane, Maharashtra -421303
21	GALVANISING	Saral Projects & Processors	B-1, Industrial Area, Site-II, Amawan Road Rae Bareli
22	GALVANISING	Brahampuri Steels Limited	172 (F) Industrial Area, Jhotwara, Jaipur-302013
23	GALVANISING	Indiana Gratings PVT. LTD	F-5, MIDC Jejuri, Pune-412 303
24	GALVANISING	M/s AVAIDS TECHNOVATORS PVT. LTD.	131, MATSYA INDUSTRIAL AREA, ALWAR RAJASTHAN

## NOTES:

- IT SHALL BE THE RESPONSIBILITY OF THE VENDOR TO GET THE MATERIAL GALVANIZED FROM THE ABOVE LIST WITHOUT ANY COMMERCIAL IMPLICATION TO BHEL

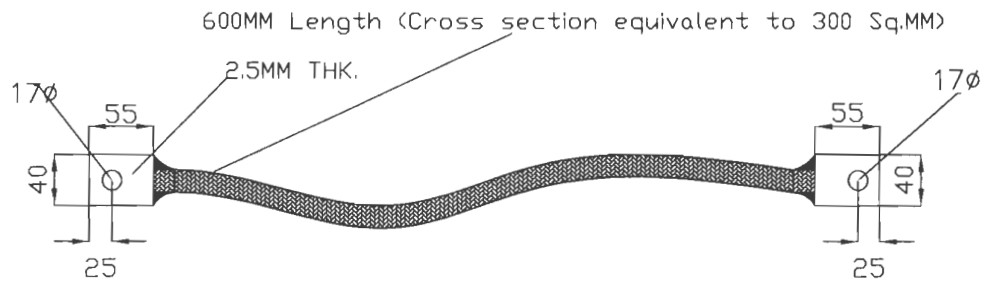
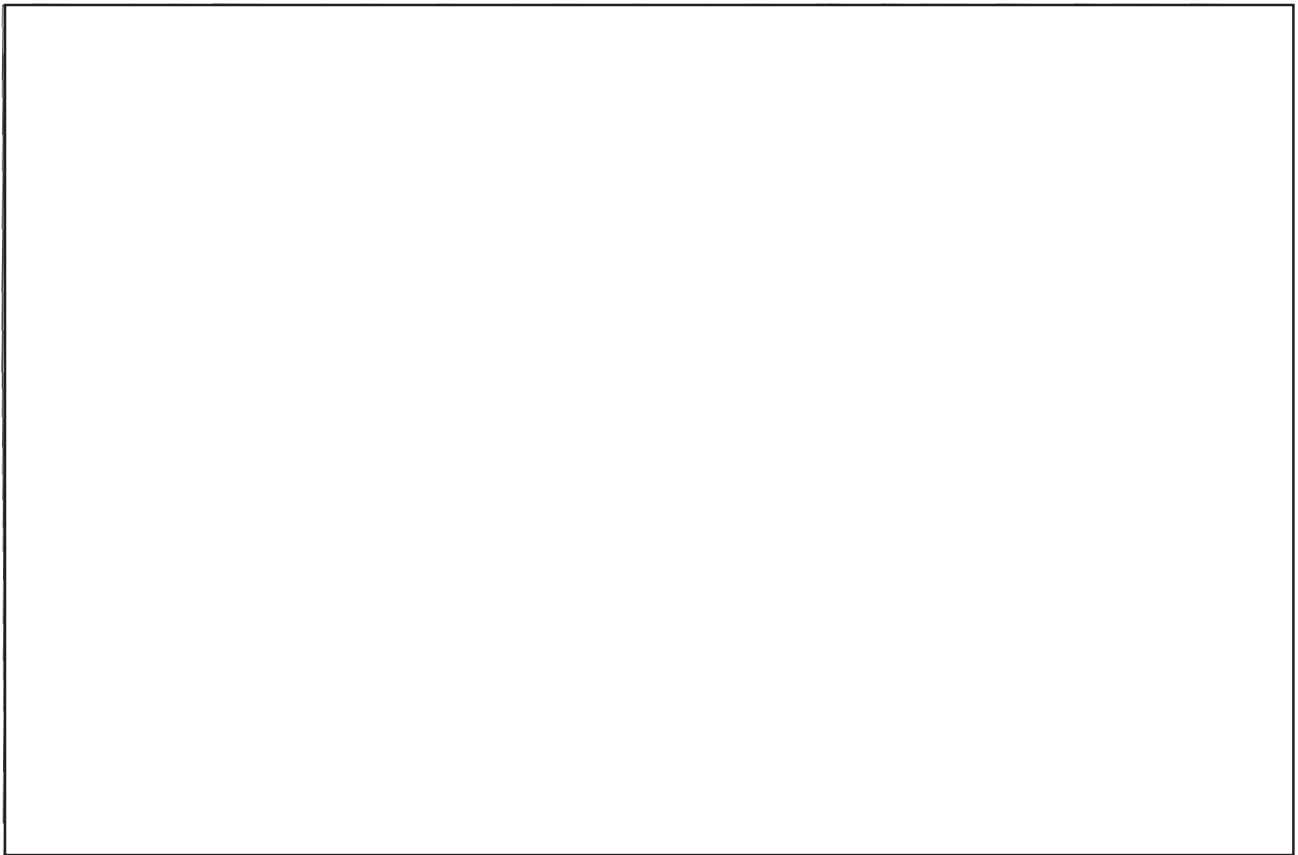

FLEXIBLE BRAIDED COPPER CONDUCTOR

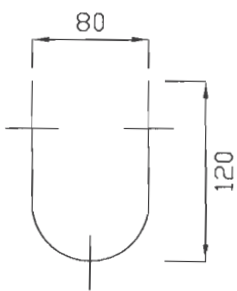

PLAN

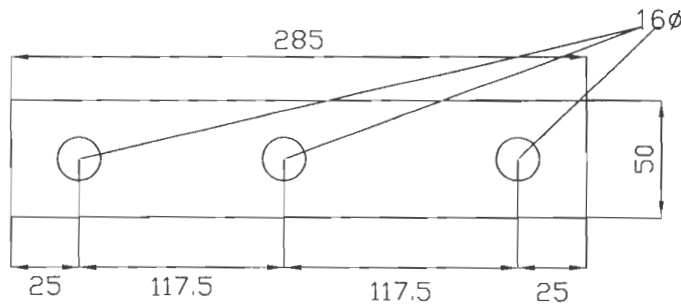

TINNED COPPER 'U' CLAMP (2.5 MM THICK)



TITLE

TYPICAL DETAILS OF FLEXIBLE  
BRAIDED COPPER,

PE-DG-999-509-E003

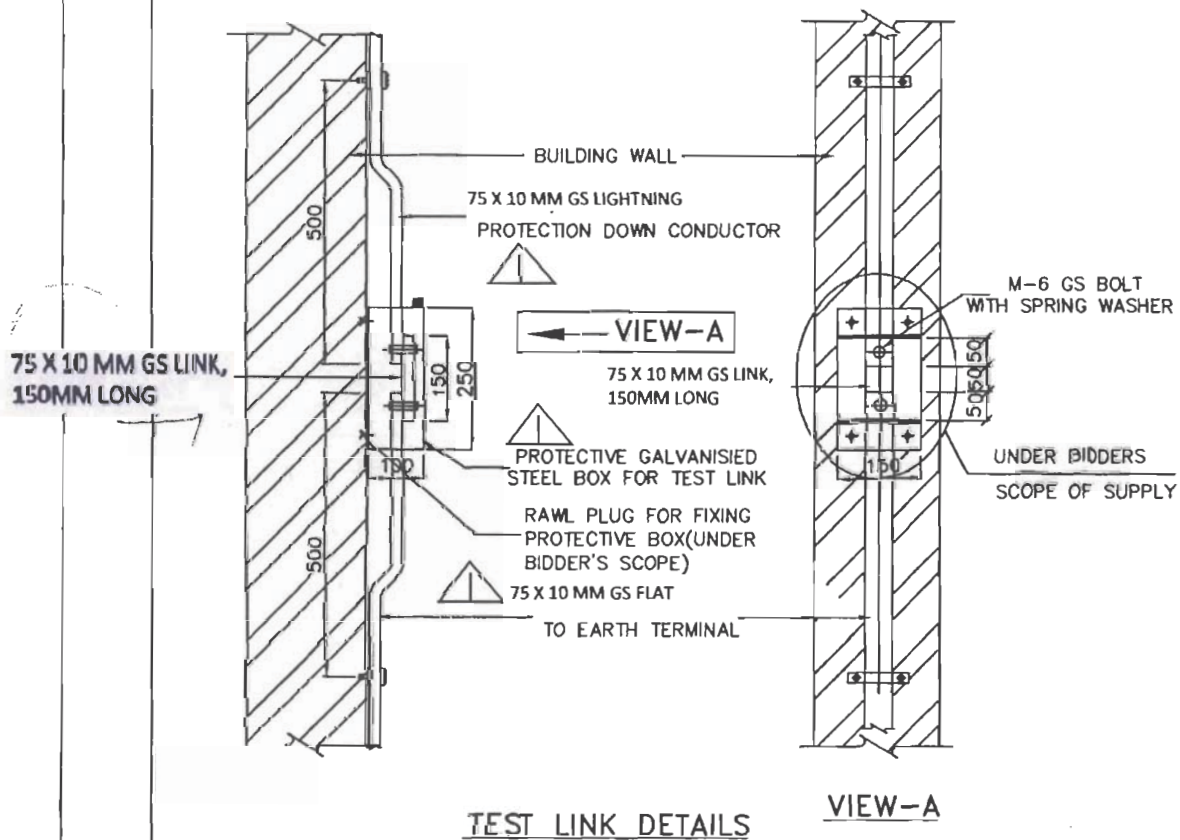

	TITLE	PE-DG-417-509-E004
	TYPICAL DETAILS OF TEST LINK WITH PROTECTIVE BOX	
		REV 4

	<b><u>Price Variation Formulae</u></b>	ANNEXURE-B
---	--	------------

Prices shall be variable as per following PVC formulae:-

ABOVE GROUND EARTHING & LIGHTNING PROTECTION MATERIALS	
$P = Po/100 (20 + 70 (Fe/Feo) + 10 (W/ Wo) )$	Indices to be taken from IEEMA Circular ( PVC/LA conductor-LME) for the applicable month.

Wherein,

P = Ex-works price payable as adjusted in accordance with the price variation clause.

Po = Ex-works price quoted/confirmed.

FEo = Price of High Tensile Galvanized Steel Wire in Rs./MT of appropriate size. This price is applicable prevailing as on 1st working day of the month **one** month prior to date of tender enquiry.

Wo = All India average consumer price index number for industrial workers, as published by the Labour Bureau, Ministry of Labour, Govt. of India (Base: 2016 = 100). This index number is as applicable on the first working day of the month, **one** month prior to date of tender enquiry.

FE = Price of High Tensile Galvanized Steel Wire in Rs./MT of appropriate size. This price is applicable prevailing as on first working day of the month **one** month prior to the date of inspection call.

W = All India average consumer price index number for industrial workers, as published by the Labour Bureau, Ministry of Labour, Govt. of India (Base: 2016 = 100). This index number is as applicable on the first working day of the month, **one** month prior to the date of inspection call.

**NOTE: PVC shall be applicable for 'GS FLATS & GI WIRES' only.**

Price of FE & FEo shall be of 3.00 to 4.09 mm High Tensile Galvanized Steel Wire.

Price variation shall be limited to +10% of total Ex-works price actually supplied and no limit on -ve price variation with base month of one month prior to date of tender enquiry for the items where PVC is applicable.

	<b>YADADRI TPS (5X800 MW)</b> <b>PRE-QUALIFICATION REQUIREMENTS FOR</b> <b>ABOVE GROUND EARTHING MATERIALS</b>	PE-PQ-417-509-E002
		REVISION NO. 00      DATE 27.07.2023
		SHEET NO. 1 OF 1

<b>ITEMS:</b> GS flats, GS rods, perforated pipe, GI stranded wires, shielding mast, test links & flexible braided copper conductor	
<b>SCOPE:</b> Supply: YES; Erection & Commissioning: NO;	
1	Supplied GS flats/GS rods/perforated pipe/GI stranded wire/shielding mast/test links/flexible braided copper conductor.
2	Vendor should have capability of supplying galvanized flats / channels/angles/structure of 40 MT per month.
3	Vendor has his own galvanization plant. Vendor to furnish details of galvanizing process zinc bath details, type of furnace, details of temperature monitoring, details of ETP etc.  OR  Vendor should get galvanization of earthing material done from any of BHEL-PEM approved galvanizers.
4	Supplied at least 300 MT of galvanized flats/channels/angles/structure in one or more and at least 100 MT in a single order.
5	Minimum two (2) nos. purchase orders for galvanized flats/channels/angles/structure shall be submitted which should not be more than five (5) years old from the date of techno-commercial bid opening for establishing continuity in business.

**Notes (General points of PQR):**

1. Consideration of offer shall be subject to customer's approval of bidders, if applicable
2. Bidder to submit all supporting documents in English. If documents submitted by bidder are in language other than English, a self- attested English translated document should also be submitted.
3. Notwithstanding anything stated above, BHEL reserves the right to assess the capabilities and capacity of the bidder to perform the contract, should the circumstances warrant such assessment in the overall interest of BHEL.
4. After satisfactory fulfilment of the above criteria/ requirement, offer shall be considered for further evaluation as per NIT and all the other terms of tender.

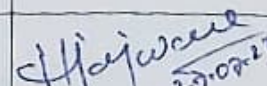
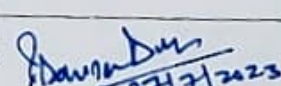
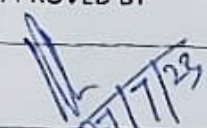
PARTICULARS	PREPARED BY	CHECKED BY	REVIEWED BY	APPROVED BY
SIGNATURE & DATE:				
NAME:	PRATIK V NAYAKA	NN JAIWARE	PRAVEEN DUTTA	DEBASISA RATH
DESIGNATION	MANAGER	SR. MGR	AGM	AGM (DH-ELECTRICAL)