

BHARAT HEAVY ELECTRICALS LIMITED
TIRUCHIRAPPALLI - 620 014

MATERIAL HANDLING SYSTEM / PE(BOILERS)



TITLE SHEET

Gravimetric Feeder
Specification for
BUSHING

Specification Number : **GF-061**
PGMA : **65-736**
65-724
65-224
65-070
65-060

Revision No. : 04

04	24-03-07	Specification revamped	
03	21-12-95	0.5 X 45 Chamber Added.	-sd-
02	21-11-93	Tolerances & Note Added.	-sd-
01	06-08-90	✓ Machining Added In ID. Based On The Meeting Held On 26.07.90	-sd-
Rev. No.	Date	Revision Statement	Checked. & Appd.

	NAME	SIGNATURE	DATE
PREPARED	S.SELVARAJU	-Sd-	22-04-88
CHECKED	D.K.R	-Sd-	22-04-88
APPROVED	M.A.S	-Sd-	22-04-88



Gravimetric Feeder
Specification for
BUSHING

Spec. No.

GF-061

Rev. 04

Sheet

02 of 02

Material code :96-424-064

Feeder Size: 36"/24", Gravimetric / Volumetric feeder

NO.OFF/FEEDER :14

Location : HEAD PULLEY

Description :HEAD PULLEY BUSHING MADE OF TWO PARTS
AS SHOWN IN THE FIGURE.

MATERIAL :
METAL PART – BRONZE
ELASTOMER – NEOPRENE (50-55 SHORE 'A')

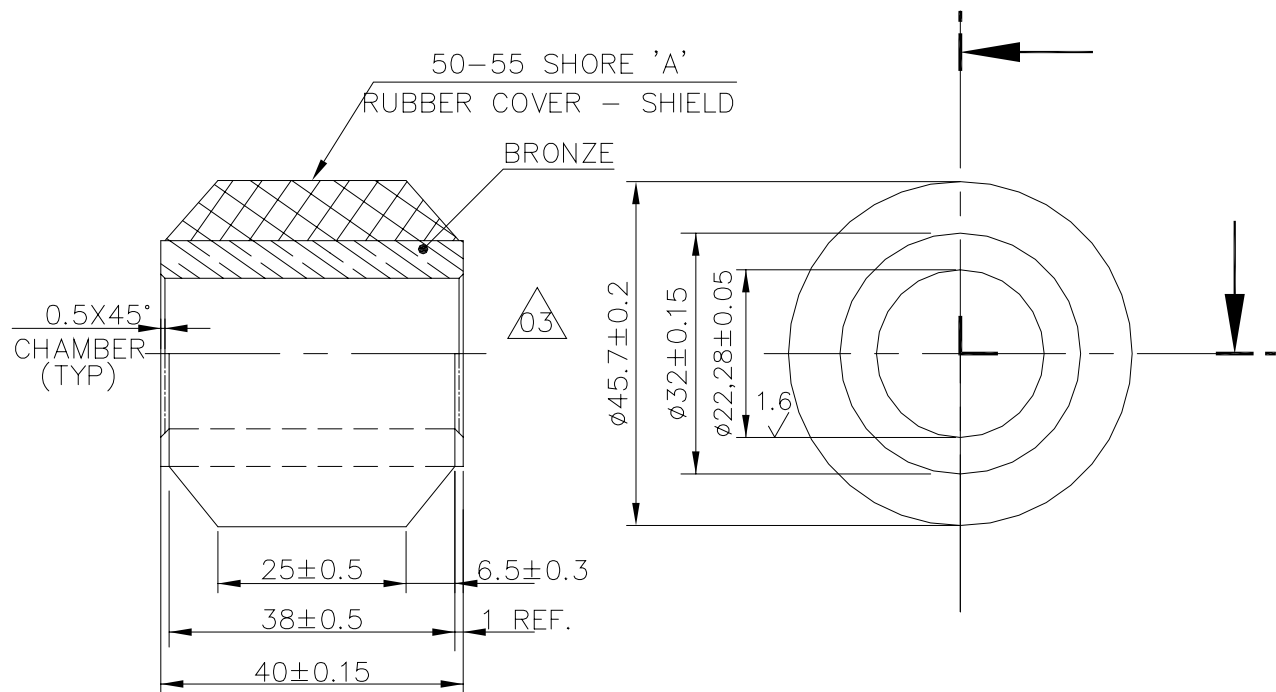

ALL DIMENSIONS ARE IN MM
M/S STOCK PART NO.W22181-1