

BHARAT HEAVY ELECTRICALS LIMITED
TIRUCHIRAPPALLI - 620 014

FUEL SYSTEM / PE(FB)



TITLE SHEET

**Specification for
Bushing-Drive stud**
(For dual belt gravimetric feeder)

PGMA=65-224

SPECIFICATION NUMBER : GF-344/00

Rev. No.	Date	Revision Statement	Checked & Approved
		First Release	

	Name	Signature	Date
Prepared	S.Mnivannan		21-11-05
Checked	S.Selvaraju		21-11-05
Approved	S.Selvaraju		21-11-05

Page No.01/02



Specification for
Bushing-Drive stud
For dual belt gravimetric feeder

SPEC. NO.
GF-344

Page
No.2/2

Feeder size : 24" Dual belt gravimetric feeder
No. of/feeder : 6
Location : 65-224 (Dual belt head pulley)
Description : Dual belt head pulley bushing made of two parts as per the following illustration.

Material of construction : Metal part - Bronze
Elastomer - Neoprene (50-55 shore 'A')

Note : The manufacturer shall provide the details regarding manufacturing date and shelf life of the product.

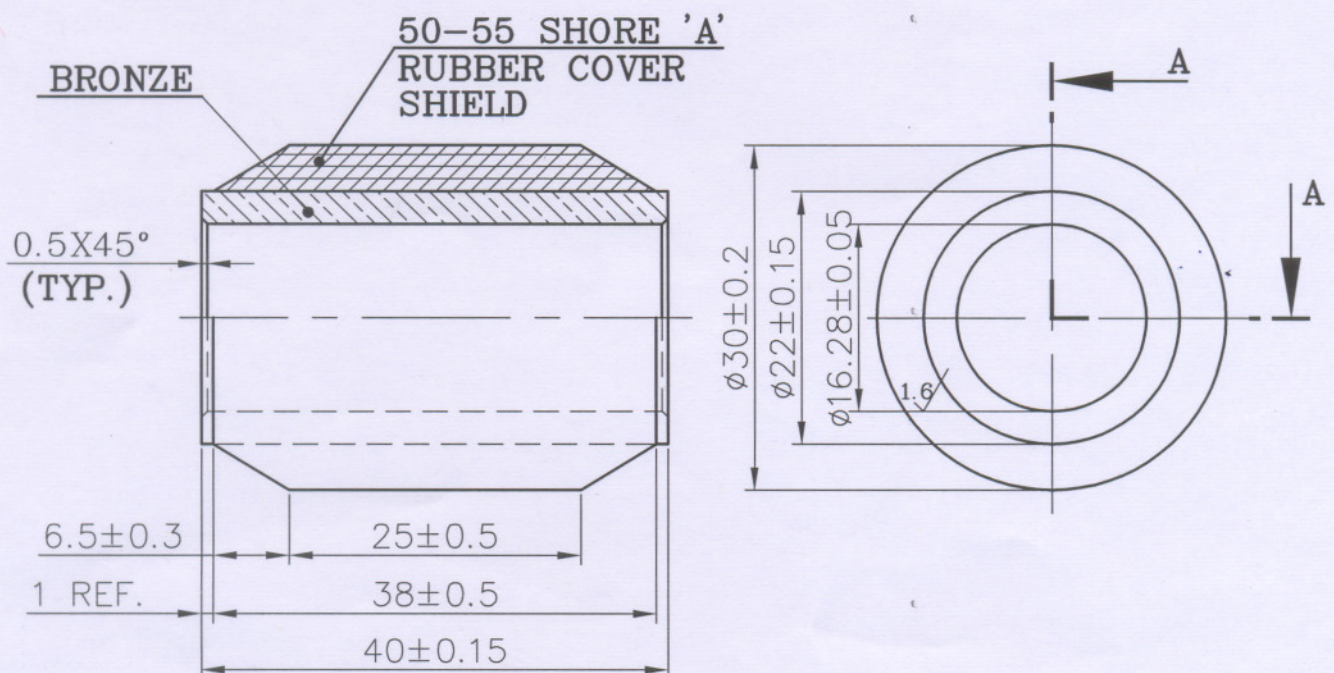

SECTION A-A

ALL DIMENSION ARE IN MM