

MATERIAL DESCRIPTION & SPECIFICATION (Catalogue):-

Enquiry Srl No.	Item Detail	BHEL Material code
1.	SLOT ANGLE, G8*12*127.5*4422 DRG: 31360501084 REV: 02 SPEC: TG60046 REV: 07 GRADE: EP-GL-NOMEX	W98413601410
2.	PACKING SPEC: TG60046 REV: 07 SIZE: 1.4X34.5X245	W98413600103
3.	PACKING SPEC: TG60046 REV: 07 SIZE: 1.4X64.8X245	W98413600090
4.	PACKING SPEC: TG60046 REV: 07 SIZE: 1.4X30X173	W98413600081
5.	SLOT ANGLE TYPE'A' SPEC: TG60046 REV: 07 SIZE: 15X66X245	W98413600073
6.	SLOT ANGLE TYPE A SPEC: TG60046 REV: 07 SIZE: 24.5X80X178	W98413600065
7.	SLOT ANGLE VAR00 SPEC: TG60046 REV: 07 DRG: 21360501047 REV: 03	W96413602139
8.	SLOT ANGLE TYPE A SPEC: TG60046 REV: 07 SIZE: A24.5 X 49 X 205	W98413601398
9.	SLOT ANGLE TYPE A SPEC: TG60046 REV: 07 SIZE: A 24.5 X 53.5 X 177	W98413601401

S No	Tender Term and Condition	Confirmation from bidder
General Requirements		
1.	Bidder to provide the documents as per pre-qualification requirements (PQR).	
2.	Bidder who fails to qualify Pre-qualification requirement, their offer will not be considered for technical evaluation and price bid opening part (part -2 of this tender).	
3.	NTPC un-approved vendor(s) to submit credentials in NTPC sub-supplier questionnaire format for take up with NTPC for approval. Vendor to confirm to follow NTPC approval condition (if any).	
4.	Ordering will be done on NTPC approved vendor(s) only as well as Price Bid (Part-II) will be opened only of those bidder(s) who qualify Part-1 bid (PQR), whose techno-commercial bid is acceptable to BHEL and who gets approve by end customer/NTPC before price bid opening.	
5.	Bidder to confirm that their quoted unit price in this tender is all-inclusive of basic rate, freight, insurance, packing & forwarding charges & any other charges if applicable + applicable GST.	

6.	Bidder to inform % of GST.	
7.	Term and condition shall be as per GeM T&C and GEM tender.	
9.	Confirm that there is no deviation with respect to BHEL Specifications. However, deviations, if any, are to be listed as a separate attachment. The offers that do not meet the substantial requirements of our enquiry are liable to be ignored. The bidders shall be deemed to comply with all the requirements of bidding documents except for listed deviations without any extra cost irrespective of any mention to the contrary anywhere else in the bid.	
10.	Please confirm that in case of breach of contract, recovery of an amount equivalent to 10% of the contract value shall be done from your pending bills etc.	
<u>QUALITY REQUIREMENTS</u>		
1.	Vendor to submit Test Certificate (TCs) as per BHEL Specifications & QAP along with dispatch documents at the time of supply.	
2.	Vendor to submit Guarantee Certificate for a period of 12 months from the date of supply, along with dispatch documents at the time of supply.	
3.	Pre-Inspection will be done by BHEL/BHEL nominated inspection agency Intertek & NTPC at vendor works as per BHEL specification & NTPC approved Quality Plan.	
4.	Vendors to submit endorsed copy of BHEL QP "QA/BEQP/076 REV. 05". in case of ordering, endorsed QP shall be forwarded to NTPC for their approval. Vendors to confirm to follow NTPC approved QP.	

Important Instruction to bidders.

1. Following attachment with this Catalogue for tender preparation.
 - Pre-qualification requirement (PQR)
 - BHEL QP Format
 - FCA
2. All supporting document shall be sign and stamped by bidder.
3. FCA is required to be signed & stamped on every page after filling relevant details. Other cross referred documents (Specifications &/or Drawings) can be obtained by email duly signed & Stamped FCA to lalitk@bhel.in &/or vbskush@bhel.in.

PRE-QUALIFICATION REQUIREMENTS (TECHNICAL) FOR
Slot Angle & Bottom Packing (TG60046)

INTRODUCTION: The Rotor Slot Angle is a L-type profile used as rotor slot insulation in rotor winding of Turbo Generators. The slot angles shall be manufactured from Epoxy glass cloth with a layer of Nomex paper sandwiched in between. The slot angles have a temperature index of 155°C. There are two types of slot angles Type A (L- type) & Type B (Club footed L- type). Bottom Packings are rectangular strips of same construction as that of Slot Angles.

1. **EXPERIENCE:** The vendor should be a manufacturer (OEM) or OEM's Authorized Distributor / Channel Partner / Sister Concern / Group Company, with OEM having the experience of successfully manufacturing and supplying the Rotor Slot Angles to OEMs of Turbo-Generators of capacity 200MW and above. In support of which, vendor to submit the following documents: -
 1. Unpriced Copy of two successfully executed purchase orders for above Slot Angle manufactured by above process and raw material for application in Turbo-Generator of capacity 200MW and above., of which at least one P.O. should be of the material supplied during last seven years from date of enquiry.
 2. Copy of Test Certificates (for dimensional, mechanical and electrical test, etc.) for the above Slot Angle corresponding to anyone of purchase order (not more than seven years old) submitted against clause no 1.1.
 3. Documentary evidence of acceptance of material, pertaining to purchase order for which TC has been submitted.
2. **MANUFACTURING FACILITIES:** Vendor/OEM to confirm that they have all in-house manufacturing facilities for above Rotor Slot Angle meeting the requirements as per BHEL specification TG60046 rev 07.
3. **TESTING FACILITIES:** Vendor/OEM to confirm that they have in-house test facilities, sufficient to carry out all the test as per enquired specification TG60046 rev 07. In case vendor conducts test at an external testing agency, vendor to furnish the details of the same, e.g. NABL accredited/Government approved Lab.
4. Vendor to provide the product technical datasheet or details/TC of raw materials being required for manufacturing the enquired item.
5. Vendor to confirm the detailed technical requirements given in the enquired specification and drawing (if any).
6. Vendor who is supplying this item to BHEL for the first time have to submit one set of samples (Size & Quantity given in Table -1) for testing the material as per Clause 6.0 of per specification TG60046 rev 07. Vendor will be qualified on the basis of successful laboratory evaluation of samples as per specification TG60046 Rev 07, in addition to qualifying other requirements of PQR.

TABLE - 1			
S.no	Test	Size(in mm)	Quantity
1	Density	Length/Width/Thickness = 20/20/1.4 mm	3
2	Glass content (for 1.4mm thick sided slot angle)	Length/Width/Thickness = 50/50/1.4 mm	3
3	Tensile Strength	Dimensions as per ISO527-2 (Type 1 B)	5
4	L Strength @RT & 150°C*	15 mm wide strip along the width of the Slot Angle	10
5	Electrical Strength	Length/Width/Thickness = 150/150/1.4 mm	3
6	Electrical Strength in Bent state	Length/Width/Thickness = 135/80/1.4 mm	3
7	Glass transition temperature by DSC	Length/Width/Thickness = 35/15/1.4 mm	3

(NITIN RAO)
 Manager / ISE&CPL

Shivanshu
 11/01/23
 SHIVANSHU
 E3/EME

ASHA GUPTA
 SDGM - EME

Anand Kumar
 11/01/2023
 Anand Kumar
 Agm (ISG, CPL, SRI)

Tensile Strength Test Specimen Dimensions (Type 1B):

Specimen type		1A	1B
l_3	Overall length ^a	170	≥ 150
l_1	Length of narrow parallel-sided portion	80 ± 2	$60,0 \pm 0,5$
r	Radius	24 ± 1	$60 \pm 0,5$
l_2	Distance between broad parallel-sided portions ^b	$109,3 \pm 3,2$	$108 \pm 1,6$
b_2	Width at ends	$20,0 \pm 0,2$	
b_1	Width at narrow portion	$10,0 \pm 0,2$	
h	Preferred thickness	1.4	
L_0	Gauge length (preferred)	$75,0 \pm 0,5$	$50,0 \pm 0,5$
	Gauge length (acceptable if required for quality control or when specified)	$50,0 \pm 0,5$	
L	Initial distance between grips	115 ± 1	115 ± 1

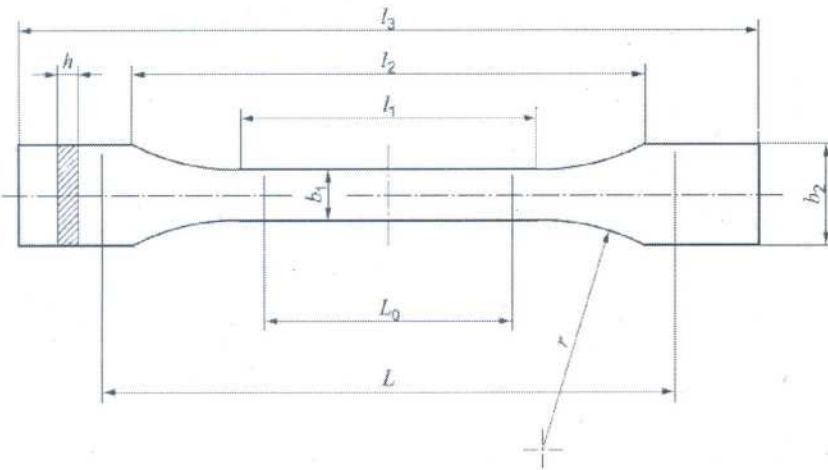

NOTE

- BHEL reserves the right to verify the information submitted by the vendor. In case the information is found to be false or incorrect, the offer shall be rejected.
- All the documents should be furnished in English language only. If the document provided by vendor is in any language other than English, it must be supported with its certified English translation.
- In case vendor is Authorized Distributor / Channel Partner / Sister Concern / Group Company, experience e/manufacturing & testing facilities of OEM may also be considered.

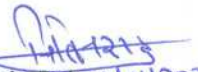
Nitin Raj 11/01/2023
Manager / ISE & CPL

11/01/23
Dy. Mgr / EME

11/01/23
SDGM / EME

11/1/23
Anirudha Tijare
AGM / ISE, CPL & GRI

MANUFACTURER'S NAME AND ADDRESS			QUALITY PLAN											
BHEL		ITEM	Rotor Slot Angle	QP NO.	QA/BE/QP/076									
		DRG. NO.	AS PER PO	REV	05									
		SPEC.	TG60046 Rev. 07				Page 1 of 2							
SL. NO.	COMPONENT & OPERATIONS	CHARACTERISTICS	CLASS	TYPE OF CHECK	QUANTUM OF CHECK	REFERENCE DOCUMENT	ACCEPTANCE NORMS	FORMAT OF RECORDS	AGENCY			REMARKS		
1	2	3	4	5	6	7	8	9	D	M	B	N	10	11

1.	Raw material Inspection	1) Glass Epoxy Prepregs													
		Grammage	Major	Physical	1 Roll from each batch/lot	BHEL SPEC & Drg.	BHEL SPEC & Drg.	Supplier TCs	√	P	V	-			
		Thickness	Major	Physical		BHEL SPEC & Drg.	BHEL SPEC & Drg.		√	P	V	-			
		Glass content	Major	Chemical		BHEL SPEC & Drg.	BHEL SPEC & Drg.		√	P	V	-			
		2) Nomex paper 410													
		Thickness	Major	Physical	1 Roll from each batch/lot	BHEL SPEC & Drg.	BHEL SPEC & Drg.	Supplier TCs	√	P/V	V	-			
		Grammage	Major	Physical		BHEL SPEC & Drg.	BHEL SPEC & Drg.		√	P/V	V	-			
		Dielectric strength	Major	Electrical		BHEL SPEC & Drg.	BHEL SPEC & Drg.		√	P/V	V	-			
Tensile strength (MD)	Major	Mechanical		BHEL SPEC & Drg.	BHEL SPEC & Drg.		√	P/V	V	-					
2.	In process/ Final Inspection (Physical Properties)	Thickness (SA, BP& SC)	Critical	Physical	For each slot angle	BHEL SPEC & Drg.	BHEL SPEC & Drg.	Test Certificates	√	P	W*	-			
		Long leg width (SA, BP& SC)	Critical	Physical	For each slot angle	BHEL SPEC & Drg.	BHEL SPEC & Drg.	TCs	√	P	W*	-			
		Short leg width (SA, BP& SC)	Critical	Physical	For each slot angle	BHEL SPEC & Drg.	BHEL SPEC & Drg.	TCs	√	P	W*	-			
		Length (SA, BP& SC)	Critical	Physical	For each slot angle	BHEL SPEC & Drg.	BHEL SPEC & Drg.	TCs	√	P	W*	-			
		Straightness (SA)	Critical	Physical	For each slot angle	BHEL SPEC & Drg.	BHEL SPEC & Drg.	TCs	√	P	W*	-			
		Density (SA, BP& SC)	Critical	Physical	2 slot angles per lot	BHEL SPEC & Drg.	1.55 ± 0.1 gm/ cc	TCs	√	P	W	-			

MANUFACTURER/SUBCONTRACTOR	LEGEND: ! RECORDS IDENTIFIED WITH 'TICK' SHALL BE ESSENTIALLY INCLUDED BY CONTRACTOR IN QA DOCUMENTATION. M: MANUFACTURER / SUBCONTRACTOR(BHEL Bangalore) B: BHEL / NOM. INSPECTION AGENCY N: CUSTOMER INDICATE 'P' PERFORM 'W' WITNESS AND 'V' VERIFICATION ALL 'W' INDICATED IN COLUMN 'N' SHALL BE 'CHP' OF CUSTOMER	FOR CUSTOMER USE
		APPROVED BY Digitally signed by Nishant Kumar Date: 2021.09.01 14:03:19 +05'30'

MANUFACTURER'S NAME AND ADDRESS		QUALITY PLAN											
BHEL		ITEM	Rotor Slot Angle	QP NO.	QA/BE/QP/076	Page 2 of 2							
		DRG. NO.	AS PER PO	REV	05								
		SPEC.	TG60046 Rev. 07										
SL. NO.	COMPONENT & OPERATIONS	CHARACTERISTICS	CLASS	TYPE OF CHECK	QUANTUM OF CHECK	REFERENCE DOCUMENT	ACCEPTANCE NORMS	FORMAT OF RECORDS		AGENCY			REMARKS
1	2	3	4	5	6	7	8	9	D	10			11

		% Shrinkage (SA)	Critical	Physical	2 slot angles per lot	BHEL SPEC & Drg.	<2 mm in length. No dimensional variation, No deformation after subjected to heating 160 °C for 6 Hrs.	TCs	√	P	W	-	
		Metal /inclusion (SA, BP& SC)	Critical	Physical	For each slot angle	BHEL SPEC & Drg.	Free from Metal/Foreign Particles(Calibrate Metal detector for 10 mg metal for Minimum detection)	TCs	√	P	W*	-	
3.	Composition	Glass Fabric content (SA, BP& SC)	Critical	Chemical	2 samples per lot	BHEL SPEC & Drg.	50 ± 5%	TCs	√	P	W	-	
4.	Mechanical Properties	Tensile strength (SA)	Critical	Mechanical	2 samples per lot	BHEL SPEC & Drg.	≥170 N/mm2	TCs	√	P	W	-	
		L- strength (SA & SC)	Critical	Mechanical	2 samples per lot	BHEL SPEC	BHEL SPEC	TCs	√	P	W	-	
		Visual inspection (SA, BP& SC)	Major	Visual	For each slot angle	BHEL SPEC & Drg.	BHEL SPEC & Drg.	TCs	√	P	W*	-	
5.	Electrical Properties	1min proof voltage test (SA)	Critical	Electrical	For each slot angle	BHEL SPEC & Drg.	12 KV	TCs	√	P	W*	-	
		Electrical strength in Bent state (SA)	Major	Electrical	2 samples per lot	BHEL SPEC & Drg.	≥ 10 KV	TCs	√	P	W	-	
6.	Thermal Properties	Glass transition temperature (SA, BP& SC)	Major	Thermal	2 samples per lot	BHEL SPEC	≥160 °C	TCs	√	P	V	-	
7.	Identification Marking & Dispatch	Identification	Minor	Visual	For each slot angle	BHEL SPEC & Drg.	BHEL SPEC & Drg.	TCs	√	P	W	-	
		Test certificate	Minor	Doc. Review	For each supply	BHEL SPEC & Drg.	BHEL SPEC & Drg.	TCs	√	P	V	-	
		Packing	Minor	Doc. Review	For each slot angle	BHEL SPEC & Drg.	BHEL SPEC & Drg.	TCs	√	P	-	-	

Abbreviation:

SA: Slot Angle, BP: Bottom Packing, SC: L-shape Small components.

MANUFACTURER/SUBCONTRACTOR	LEGEND:	FOR CUSTOMER USE	APPROVED BY
	! RECORDS IDENTIFIED WITH 'TICK' SHALL BE ESSENTIALLY INCLUDED BY CONTRACTOR IN QA DOCUMENTATION.		
	M: MANUFACTURER / SUBCONTRACTOR(BHEL Bangalore) B: BHEL / NOM. INSPECTION AGENCY N: CUSTOMER INDICATE 'P' PERFORM 'W' WITNESS AND 'V' VERIFICATION ALL 'W' INDICATED IN COLUMN 'N' SHALL BE 'CHP' OF CUSTOMER		

Digitally signed by
Nishant Kumar
Date: 2021.09.01
14:03:36 +05'30'

Certificate

In line with Government Public Procurement (Preference to Make in India), Order 2017, P-45021/2/2017-PP (BE-II) dated 16.09.2020, we hereby certify that we M/s _____ (supplier name) are local supplier meeting the requirement of minimum local content _____ (in %) as defined in above order for the material against Enquiry No. _____

Details of location at which local value addition will be made is as follows:

We also understand, false declarations will be in breach of the Code of Integrity under Rule 175(1)(i)(h) of the General Financial Rules for which a bidder or its successors can be debarred for up to two years as per Rule 151 (iii) of the General Financial Rules along with such other actions as may be permissible under law.

Seal and Signature of Supplier

Framework Confidentiality Agreement cum Undertaking

This Agreement made on this the _____ day of (month) _____ 20____ (“Effective Date”) by and between
M/s BHARAT HEAVY ELECTRICALS LIMITED, having registered office at “BHEL House”, Siri Fort, New Delhi – 110049 (India), acting through its _____ Unit (hereinafter may be referred to as “BHEL” or “the Company”).

And

M/s _____ (address) _____
represented by authorized representative Sri _____ (herein after referred to as the “Supplier”).

The Supplier and the Company may, unless the context otherwise requires, hereinafter be collectively referred to as “Parties” or singly as the “Party”.

RECITALS

Whereas, BHEL is engaged in the design, engineering, manufacturing, construction, testing, commissioning and servicing of a wide range of products, systems and services for the core sectors of the economy, viz. Power, Transmission, Industry, Transportation, Renewable energy, Oil & Gas and Defence and providing associated services to varied customers in relation to which BHEL/its affiliates own valuable information of a secret and confidential nature.

Whereas the Company may, in connection with Contract(s) (as defined hereunder) placed or to be placed upon the Supplier, or otherwise, from time to time, make available, Technical Information as is defined hereunder.

And Whereas BHEL is willing to provide such Technical Information to the Supplier from time to time and the Supplier understands and acknowledges that such Technical Information is valuable for the Company and as such is willing to protect confidentiality of such information, subject to the terms and conditions set out hereunder.

Now therefore, in view of the foregoing premises and in consideration of the mutual covenants and agreements hereinafter set forth, the Parties agree as under:

1. Definitions:

Unless the context so requires, in this Agreement, the following terms will bear the meaning ascribed to the said term in this clause.

- A. **“Contract”** means the Contract entered into with a Supplier and includes a Purchase Order, or a Work Order for procurement of any goods or for provision of any services.
- B. **“Effective Date”** means the date of this Agreement as mentioned in the preamble of this Agreement.

- C. **“Supplier”** includes a Contractor or a Vendor of the Company whether for supplying of goods or for providing any services under a Contract or both.
 - D. **“Technical Information”** includes Drawings, and/or Product Standards and/or Specifications and/or Corporate / Plant Specifications and/or Technological Process Sheets and/or Technical Data Sheets and/or Jigs & Fixtures and/or Pattern & Dies and/or Special Gauges and/or Tools etc. belonging to or wherein the Company has acquired from a third party a right of user and includes any improvement thereto from time to time whether carried out by the Company or by the Supplier.
 - E. **“Intended Purpose”** means the purpose for which the Technical Information is provided to the Supplier under or in connection with a Contract.
 - F. **“Improvement”** includes any modification made to, or adaptation of, the Technical Information which enhances or is calculated to enhance the performance (whether in terms of effectiveness or in terms of efficiency or both) of the product and/or the service to be provided by the Supplier under a Contract.
2. This Agreement shall come into force/deemed to have come into force, as the case may be, on the Effective Date; or, on the first date when the Technical Information or any part thereof is provided by BHEL to the Supplier; whichever is earlier.
3. **Agreement deemed to be incorporated in each Contract:** Unless and to the extent otherwise stipulated in the Contract, the conditions of this Agreement are deemed to be incorporated in all Contracts which may be entered into between the Company and the Supplier. Further, unless otherwise stipulated, the obligations under this Agreement are and will be independent of the obligations under the Contracts and such obligations of the Supplier hereunder will remain of full effect and validity notwithstanding that the period of validity of the Contracts has expired by efflux of time stipulated therein; or, the contract has been discharged by performance or breach; or, the termination of the Contracts for any reason whatsoever.
4. **Ownership:**
- 4.1 The Company may, from time to time, make available to the Supplier, Technical Information on a non-exclusive basis by way of loan.
 - 4.2 The Supplier acknowledges and agrees that all Technical Information and copies thereof that are or may be provided by the Company to the Supplier, are and shall remain the property of BHEL or that of the concerned entity from whom BHEL has obtained the Technical Information and such Technical Information are and shall constitute trade secrets of the BHEL. Nothing in this Agreement or in any disclosures made hereunder by or on behalf of the Company shall be construed as granting upon the Supplier any patent, copyright or design or any other intellectual property rights of whatsoever description that subsists or may hereinafter exist in the Technical Information. Furthermore, nothing in this Agreement or in any disclosures made hereunder by or on behalf of the Company shall be construed as granting upon the Supplier any license or rights of use of such patent, copyright or design or any other

intellectual property rights of whatsoever description which may now or hereafter exist in the Technical Information except for use of the Technical Information strictly in accordance with this Agreement and the Contract and/or as directed in writing by the Company, solely for the Intended Purpose under the Contract.

- 4.3 Neither Party is obligated by or under this Agreement to purchase from or provide to the other Party any service or product and that any such purchase/sale of any product and/or service by one Party to the other Party will be governed by the Contract if any, that may be entered into by and between the Company and the Supplier.
- 4.4 The Supplier is/has been made well aware and acknowledges that the Technical Information being/which may be shared with it by the Company has been either generated by the Company by incurring huge investment and cost or obtained from foreign collaborators under Technical Collaboration Agreement (TCA) with stringent confidentiality conditions.
- 4.5 The Supplier agrees and undertakes to adhere to confidentiality requirements as applicable to BHEL under a TCA and also ensure that the confidentiality requirements are adhered to by all its concerned employees or sub-contractors/suppliers (where permitted to be engaged by BHEL). Any damages, losses, expenses of any description whatsoever, arising out of or in connection with a breach of the confidentiality requirements under a TCA owing to any act or omission on the part of the Supplier or its employees or sub-contractors/suppliers that is claimed by a foreign collaborator from the Company shall be wholly borne by the Supplier and it shall keep BHEL fully indemnified in this behalf. The demand by the Company shall be conclusive upon the Supplier who shall thereupon forthwith pay to the Company without demur, dispute or delay the amount as demanded without demanding any further proof thereof.
- 4.6 The Supplier agrees and undertakes that unless so decided and advised by the Company in writing all rights/title to any Improvement to the Technical Information shall vest in the Company. The Supplier undertakes and agrees to inform forthwith to the Company of any such Improvement made to the Technical Information and transfer all drawings/documents or other materials connected with such Improvement to the Company and also agrees to fully cooperate with the Company for protecting the Company's interests in such Improvement in the Technical Information including but not limited to obtaining necessary protection for the intellectual property rights in such improvement, if so desired by the Company. If a question arises whether a modification amounts to Improvement to the Technical Information, the same shall be decided by the Company and such decision shall be final and binding upon the Supplier.

5. Use and Non-Disclosure:

- 5.1 Unless otherwise stipulated by the Company, all Technical Information made available to the Supplier, by the Company shall be treated as Confidential irrespective of whether the same is marked or otherwise denoted to be Confidential or not.

- 5.2 The Supplier undertakes and agrees that the Technical Information in its possession shall be held in strict confidence and will be used strictly in accordance with this Agreement and solely for the Intended Purpose under the Contract. Use of the Technical Information for any other purpose other than Intended Purpose is prohibited.
- 5.3 In particular, the Supplier shall not use Technical Information or any Improvement in its possession for the manufacture or procurement of the Product(s) or components or parts thereof or use the Technical Information or any portion thereof or any modification or adaptation thereof in any form to provide any product and/or service to any third party, without the prior written consent of the Company.
- 5.4 The Supplier shall not disclose any of such Technical Information to any third party without the prior written consent of the Company. The Supplier agrees that without prior written consent of the Company, the Supplier shall not disclose to a third party about the existence of this Agreement, or of the fact that it is/was in possession of or has experience in the use of any Technical Information nor shall the Supplier share in any manner whatsoever, with a third party, the name or details of any Contract(s) awarded by the Company to it or performed by the Supplier or the scope of work thereof or share any document or correspondence by and between the Company and the Supplier in or in connection with this Agreement or such Contract(s). Notwithstanding what is stated elsewhere, the overall responsibility of any breach of the confidentiality provisions under this Agreement shall rest with the Supplier.
- 5.5 The Supplier undertakes and agrees not to make copies or extracts of and not to disclose to others any or all of the Technical Information in its possession, except as follows:
- (a) The Supplier may disclose the Technical Information to such of its officers and employees strictly to the extent as is necessary for such officer or employee for the Intended Purpose, provided that the Confidential Information (or copies thereof) disclosed shall be marked clearly as the confidential and proprietary information of Company and that such officers and employees shall similarly be bound by undertakings of confidence, restricted use and non-disclosure in respect of the Technical Information. The Supplier shall be responsible for any breach of such confidentiality provisions by such officers and employees.
 - (b) With the prior written consent of Company, the Supplier may disclose for the Intended Purpose such Technical Information as is provided for in such consent to such of its professional advisers: consultants, insurers and subcontractors who shall be similarly bound by undertakings of confidence, restricted use and non-disclosure in respect of such Technical Information.
 - (c) The Supplier shall not be prevented to make any disclosure required by (i) order of a court of competent jurisdiction or (ii) any competent regulatory authority or agency where such disclosure is required by law, provided that where the Supplier

intends to make such disclosure, it shall first consult Company and take all reasonable steps requested by it to minimize the extent of the Technical Information disclosed and to make such disclosure in confidence and also shall cooperate with the Company in seeking any protective order or any other remedy from proper authority in this matter.

6. Exceptions:

The obligations of the Supplier pursuant to the provisions of this agreement shall not apply to any Confidential Information that:

- a) was/is known to, or in the possession of the Supplier prior to disclosure thereof by the Company;
- b) is or becomes publicly known, otherwise than as a result of a breach of this agreement by the Supplier.
- c) is developed independently of the Disclosing Party by the Supplier in circumstances that do not amount to a breach of the provisions of this Agreement or the Contract;
- d) is received from a third party in circumstances that do not result in a breach of the provisions of this Agreement.

7. The obligation of maintaining confidentiality of the Technical Information on each occasion, shall subsist for the entire duration during which the Technical Information / equipment is in possession of the Supplier and shall thereafter subsist for a further period of --- years from the date when the complete Technical Information has been returned to the Company and if Technical Information has been returned in portions on different dates then, the period of ---- years will be reckoned from the date when the last portion of the Technical Information has been returned. Notwithstanding the expiry of the confidentiality obligation, the obligation of the Supplier under clause 5.4 shall continue to subsist for a further period of ----- years.

8. Warranties & Undertakings:

a) The Supplier undertakes to ensure the due observance of the undertakings of confidence, restricted use and non-disclosure by its persons to whom it discloses or releases copies or extracts of the Technical Information.

b) The Supplier shall keep the Technical Information or improvement made therein properly segregated and not mix up the same with any other material/documents belonging to him/it or to any other third party.

c) The Supplier further undertakes that he/it shall not hypothecate or give on lease or otherwise alienate or do away with any of the Technical Information and/or equipment of the Company, made available to him/it, and undertakes that he/it shall hold the same as a trustee, in capacity of custodian thereof and use/utilise the same solely for the purpose of executing the Contract awarded by the Company.

d)The Supplier further undertakes that he/it shall return all the equipment and/or Technical Information as far as practicable in the same condition in which the same was made available to him/it by the Company together with any Improvement thereon and the documents connected with such Improvement, to the Company forthwith upon completion of the scope

of work or Contract for which such Technical Information was provided by the Company to it or as directed by the Company together with a confirmation by way of an affidavit or in such manner as directed by the Company that it has not retained any equipment and/or Technical Information/Improvement thereof. In case any such equipment and/or Technical Information or Improvement thereof shall remain in his possession or is not capable of being returned, the retention and use of such Technical Information or Improvement thereto shall continue to be governed by this Agreement.

e) The Supplier undertakes to indemnify the Company for all the direct, indirect and/or consequential losses, damages, expenses whatsoever including any consequential loss of business, profits suffered by the Company owing to breach by the Supplier of its obligations under this Agreement and/or the confidentiality requirements, if any, contained in the Contract and that the Supplier hereby agrees that the decision of the Company in all such or any such matter/s shall be final and binding on the Supplier. On mere written demand of the Company, the Supplier shall forthwith and without demur or delay pay to the Company any such sum as determined by the Company as the amount of loss or damage or expense which has been suffered by the Company. The Supplier agrees that the Company shall be entitled to withhold and appropriate any amount payable to the Supplier under any Contract then existing between the Company and the Supplier, in case the Supplier fails to make payment, in terms of the written demand, within 7 days thereof. Without prejudice to the foregoing actions, in respect to any breach of this Agreement, the Company shall be entitled to take any other action against the Supplier as per applicable laws, the Contract, Company's applicable policies, guidelines rules, procedures, etc.

9. Without prejudice to any other mode of recovery as may be available to the Company for recovery of the amount determined as due as per Clause 8(e) hereinabove, the Company shall have a right to withhold, recover and appropriate the amount due towards such losses, damages, expenses, from any amount due to the Supplier in respect of any other Contract (s) placed on him/it by any department/office/Unit/Division of the said Company.

10. Arbitration & Conciliation:

a) In case amicable settlement is not reached between the Parties, in respect of any dispute
or

difference or claim or controversy arising out of the formation, breach, termination, validity or execution of the Contract(or Agreement) or the respective rights and liabilities of the parties or in relation to interpretation of any provision of the Contract or in any manner touching upon the Contract, then, either Party may, by a notice in writing to the other Party refer such dispute or difference or controversy or claim, (except as to any matters, the decision of which is specifically provided for therein) to the sole arbitration by the arbitrator appointed by Head/In-Charge of the Unit/Division/Region.

b) The Arbitrator shall pass a reasoned award and the award of the Arbitrator shall be final and binding upon the parties to the dispute.

c) Subject as aforesaid, the provisions of Arbitration and Conciliation Act 1996 (India), or other statutory modifications or re enactments thereof and the rules made thereunder and for

the time being in force shall apply to the arbitration proceedings under this clause. The seat of arbitration shall be at ----- **(Insert the name of the city/town of the concerned BHEL Unit/Division).**

d) In case of Contract with Public Sector Enterprise (PSE) or a Government Department, the following shall be applicable:

In the event of any dispute or difference relating to the interpretation and application of the provisions of the Contract, such dispute or difference shall be referred to by either party to the arbitration of one of the arbitrators in the department of public enterprises to be nominated by the Secretary to the Government of India in-charge of the Department of Public Enterprises. The Arbitration and Conciliation Act, 1996 shall not be applicable to arbitration under this clause. The award of the arbitrator shall be binding upon the parties to the dispute, provided, however, any party aggrieved by such award may make further reference for setting aside or revision of the award to the Law Secretary, Department of Legal Affairs, Ministry of Law and Justice, Government of India. Upon such reference the dispute shall be decided by the Law Secretary or the Special Secretary or Additional Secretary when so authorized by the Law Secretary, whose decision shall bind the parties hereto finally and conclusively.

e) Notwithstanding the existence or any dispute or differences and/or reference for the arbitration, the Supplier shall proceed with and continue without hindrance the performance of its obligations under this Contract with due diligence and expedition in a professional manner.

11. Governing Law & Jurisdiction:

This Agreement shall be governed by and be construed as per applicable Indian Laws in force at the relevant time.

Subject to clauses 10(a) and 10(d) hereinabove, all matters in connection with the subject agreement shall be subject to exclusive jurisdiction of Courts situated at -----**(insert the name of the place where the BHEL Unit/Division is located)**

SIGNATURE

WITNESSES

1.

Name

Address:

2.

Name:

Address: