

TENDER ENQUIRY NO.: X/6620/2021/0560/E/1

SUB: TERMS & CONDITIONS FOR PRE-FAB. M/C & FAB. ONLY OF Inner Top Cover, Outer Top Cover

NIT-Notice Inviting Tender

Salient Details of Notice Inviting Tender (NIT)		
Sl. No.	Issue	Description
1.	Item details	As per Enquiry Annexure X/6620/2021/0560/E/1
2.	Issue of Tender Documents	From BHEL eProcurement website https://eprocurebhel.co.in/nicgep/app (Tender documents will be available for downloading from BHEL e-Procurement website till due date of submission)
3.	Due Date Of Offer Submission	Date: 04-05-2022 Time: 13:45 hrs https://eprocurebhel.co.in/nicgep/app Offer to be submitted in online only through e-procurement Portal. (Bidders are requested to visit website to view corrigendum/ addenda/ amendments/ extension/ modification etc. before submitting offer).
4.	Opening of Tender (Techno-Commercial Bid)	Date: 04-05-2022 Time: 14.00 Hrs Notes: This tender being an e-tender, it shall be opened online only through the E-Procurement Portal. Participating bidders may witness the Opening online only.
5.	Cost of Tender	INR 2000/- (If hard copy of tender document is required from BHEL otherwise not applicable.)
6.	EMD (Earnest Money Deposit)	Rs. 2,00,000.00
7.	Schedule Of Pre-Bid Discussion	Not Applicable
8.	Integrity Pact & Details of Independent External Monitor (IEM)	Required- As per Enquiry Annexure X/6620/2021/0560/E/1
9.	Latest Updates	Latest updates on the important dates, Amendments, Correspondences, Corrigenda, Clarifications, Changes, Errata, Modifications, Revisions, etc to Tender Specifications will be hosted in BHEL e-tender portal https://eprocurebhel.co.in/nicgep/app and not in the newspapers. Bidders to keep themselves updated with all such information

Please submit your offer only for the above requirement subject to our **GENERAL INSTRUCTIONS AND STANDARD TERMS & CONDITIONS (Version: June-2021, Rev.06)**. Please visit our site www.hwr.bhel.com for General Instructions and Standard Terms & Conditions (GISTC) for Tender Enquiries. All the bidders/vendors must ensure compliance of these GISTC. GISTC can also be referred by login to B2B Portal for Registered Vendors.

TENDER ENQUIRY NO.: X/6620/2021/0560/E/1

Tender Fee & EMD (If Applicable) will be submitted in the form of Pay Order / Demand Draft (drawn in favor of 'BHEL HARIDWAR') only. It may be noted that if hard copy of any tender document is required, then the same may be collected against copy of Pay Order / Demand Draft of requisite tender fee (while original to be submitted with Part-I).

If EMD is not submitted along with the offer, then the offer may not be considered.

For E-Payment, the RTGS details are mentioned as below:

Bank Details	SWIFT Details of bank
STATE BANK OF INDIA RANIPUR BRANCH, OPP: BHEL MAIN GATE, SECTOR-5, RANIPUR, HARIDWAR, UTTRAKHAND, INDIA PIN CODE : 249403	SWIFT NO.: SBININBB225 CC ACCOUNT NO.: 10667995458 IFSC CODE: SBIN0000586

As per notification reference no. NSIC/HO/GP/15(4)/2013-14 dated 07.07.2013 Micro & Small Enterprises (MSEs) are not required to submit Tender fees. A Valid MSE certificate such as Udyog Aadhar (UAN)/Udyam Certificate/NSIC/EM (Part-II) etc. issued from competent authority shall be submitted in support of Micro & Small Enterprises (MSEs).

“As per the OM No. F. No. 1(2)(1)/2016-MA dated. 09.02.2017 issued from the Office of Development Commissioner (Micro, Small & Medium Enterprises), “Traders and agents should not be allowed to avail the benefits extended under the PP Policy.”

Central / State – PSUs / Government departments are exempted from submission of EMD subject to approval by BHEL management.

BHEL will forfeit the EMD if, the successful bidder / vendor refuses to honor the order after award of the same on him and / or withdraws his bid and / or unilaterally changes the offer and / or any of its terms & conditions within the validity period.

INSTRUCTIONS TO BIDDERS FOR SUBMITTING OFFER

TECHNICAL QUALIFICATION: Technical Requirement, Pre-Qualifying Requirements/PQR to be submitted. It is the mandatory requirement. Offer of vendors not meeting these requirements may not be considered.

ESSENTIAL INSTRUCTIONS

The tender shall be **submitted in two parts** in separate cover as described below on or before the due date:

Part I (Cover-1) - Containing the following:

1. Techno -Commercial Bid
2. Tender Fee & EMD (Earnest Money Deposit) Or Valid certificate/Document towards exemption of Tender fee and/or EMD (applicable for Micro and small Enterprises, Central / State – PSUs / Government departments, PMD vendors etc.)

Part II (Cover-2) - Containing Price Bid in attached Format

TENDER ENQUIRY NO.: X/6620/2021/0560/E/1

Bidders against tender will necessarily have to obtain class – III DSCs. Procedure for application available on www.bhel.com.

E-Procurement Portal Inputs

Procedure for Submission of Offer for E – Tender-Procedure for Submission of Tender is available in the “Bidder Manual for BHEL Bidders” at E-tender portal <https://eprocurebhel.co.in/nicgep/app> . Terms and conditions mentioned therein shall form integral part of the NIT and bidders shall abide by the same.

Hardware and Software requirements for participating in e-tender

Please refer the website for the minimum system requirements and setting document for Bidders under the link: <https://eprocurebhel.co.in/nicgep/app>

Digital Signature

To know the procedure for obtaining Digital Signature Certificate (DSC), suppliers who are not having the DSC are advised to visit our website [http://www.bhel.com/home.php/Tender Notifications/Sample Checklist](http://www.bhel.com/home.php/Tender%20Notifications/Sample%20Checklist).

NIC portal Helpdesk Contacts

For any technical related queries please call at 24 x 7 Help Desk Number
0120-4001 002
0120-4200 462
0120-4001 005
0120-6277 787
International bidders are requested to prefix 91 as country code

Email Support

Address: A) For any Issues or Clarifications relating to the published tenders, bidders are requested to contact the respective Tender Inviting Authority
Technical - support-eproc@nic.in

Note

Offers/tenders submitted in the E-tender portal shall only be considered for further evaluation. Offers sent by FAX / E-mail / any mode other than E-tender would not be entertained.

The Tenderers must submit their Tenders, as detailed below:

SPECIAL NOTE: All documents to be submitted should be uploaded in respective places in the E-Tender portal as per the list mentioned given in this NIT. BHEL shall not be responsible for incomplete documents.

PQR

Item : FABRICATION OF Outer Top Cover (In Quadrants)
(KALESHWARAM drg: 02030121502-00)

PRE-QUALIFICATION REQUIREMENT

01.00	TECHNICAL REQUIREMENT	Required	Vendor's Offer
01.01	Vendors should have experience of fabricating (cutting/bending/assembly/welding/pre-fabrication machining) and supplying of atleast 1 no. Outer top cover or equivalent components in last 7 years from the date of enquiry as per following details: i) Dimensions of job: Length/Diameter = 5000 mm, Breadth/diameter= 2000mm and Height= 1000 mm and above. ii) Lifting facility and capacity at vendor works should EOT crane 12 Tons and above. iii) Vendor must have levelled bed plate size : Length= 5500mm, Breadth=2500 mm and above to fabricate the job. iv) Vendor must have rolling/bending facility to bend/roll cylinder of thickness 56mm and above with width 1500mm and above. (v) Vendor must have suitable WPS/PQR and qualified welders for welding approved by third party and submit documentary evidence with offer. (vi) Vendor must have cutting facility to cut plate of thickness 150mm and above. (vii) Vendor must have drilling facility to drill hole size of 30mm and above on a plate of thickness 40mm and above.	Vendor to Comply & submit suitable evidence including technical specifications, technical brochure, photographs etc. of the facilities.	
01.02	Vendor to furnish certificate or documentary evidence against clause 01.01 from the customer / company or end user duly confirming that fabricated Outer top cover or equivalent job was supplied and used for Hydro Pump or turbine/power plant/capital goods/infrastructure application OR Vendor to submit documentary evidence as per clause 1.03.	Vendor to Comply & submit suitable documents	
01.03	Vendor to furnish name of customer/company with complete contact details and month /year of previous supply along with copy of PO, type of manufacturing facility used for fabrication (assembly/welding/pre-fabrication machining), supply documents, Payment details(invoice copy) and inspection documents of supplied Outer top cover or equivalent.	Vendor to Comply & submit suitable documents	
01.04	All PQR documents are to be stamped and signed in original by Vendor. In case documents and official stamp is in language other than English, documents and details of official stamp are to be translated in English and duly certified by Government agency/approved agency of Government/Embassy.	Vendor to Comply & submit suitable documents	
01.05	BHEL reserves the right to verify the information provided by vendor. In case the information provided by vendor is found to be false/ incorrect, their offers shall be rejected.	Vendor to agree	

NOTE: PQR is not restrictive

1
01/04/2022
Ravi Deshwal
Dy. Manager (WTX)

Sadhu
01/04/22
(Sadhu K. Goyal)
Mgc/WTX

BSR
01.04.2022
(BS Arora)
AGN-WT

PQR

Item : FABRICATION OF Inner Top Cover
(KALESHWARAM drg:02030121503-00)

PRE-QUALIFICATION REQUIREMENT

01.00	TECHNICAL REQUIREMENT	Required	Vendor's Offer
01.01	<p>Vendors should have experience of fabricating (cutting/bending/assembly/welding/pre-fabrication machining) and supplying of atleast 1 no. Inner top cover or equivalent components in last 7 years from the date of enquiry as per following details:</p> <p>i) Dimensions of job: Length/Diameter = 5600 mm, Breadth/diameter= 5600mm and Height= 2000 mm and above.</p> <p>ii) Lifting facility and capacity at vendor works should EOT crane 45 Tons and above.</p> <p>iii) Vendor must have levelled bed plate size : Length= 6000mm, Breadth=6000 mm and above to fabricate the job.</p> <p>iv) Vendor must have rolling/bending facility to bend/roll cylinder of thickness 70mm and above with width 1500mm and above.</p> <p>(v) Vendor must have suitable WPS/PQR and qualified welders for welding approved by third party and submit documentary evidence with offer.</p> <p>(vi) Vendor must have cutting facility to cut plate of thickness 130mm and above.</p> <p>(vii) Vendor must have drilling facility to drill hole size of 30mm and above on a plate of thickness 40mm and above.</p>	<p>Vendor to Comply & submit suitable evidence including technical specifications, technical brochure, photographs etc. of the facilities.</p>	
01.02	<p>Vendor to furnish certificate or documentary evidence against clause 01.01 from the customer / company or end user duly confirming that fabricated Inner top cover or equivalent job was supplied and used for Hydro Pump or turbine/power plant/capital goods/infrastructure application OR Vendor to submit documentary evidence as per clause 1.03.</p>	<p>Vendor to Comply & submit suitable documents</p>	
01.03	<p>Vendor to furnish name of customer/company with complete contact details and month /year of previous supply along with copy of PO, type of manufacturing facility used for fabrication (assembly/welding/pre-fabrication machining), supply documents, Payment details(invoice copy) and inspection documents of supplied Inner top cover or equivalent.</p>	<p>Vendor to Comply & submit suitable documents</p>	
01.04	<p>All PQR documents are to be stamped and signed in original by Vendor. In case documents and official stamp is in language other than English, documents and details of official stamp are to be translated in English and duly certified by Government agency/approved agency of Government/Embassy.</p>	<p>Vendor to Comply & submit suitable documents</p>	
01.05	<p>BHEL reserves the right to verify the information provided by vendor. In case the information provided by vendor is found to be false/ incorrect, their offers shall be rejected.</p>	<p>Vendor to agree</p>	

NOTE: PQR is not restrictive

1
01/04/2022
[Ravi Deshwal
Sr. Manager (WTR)]

Sankar
01/04/2022
(Sankar Kr Gaud
Mgt/WTR)

BS
01/04/2022
(BS Arora
Sr. Mgt)

TERMS & CONDITIONS FOR PRE-FAB. M/C & FAB. ONLY OF Inner Top Cover, Outer Top Cover.

The item name and drawing no. mentioned in the enquiry is for reference & will be available for ordering. A sample of Combined Bill of Materials and all reference drawings are also enclosed for having a general idea of the tender.

1. **SCOPE OF WORK:** -This Enquiry is for PRE-FAB. M/C & FAB. only of following items with BHEL Material as per drg., QP & other specifications.

Sl. No.	Item Description	Drg. No.	Qty.	Fabrication Weight/Piece
1	OUTER TOP COVER(INQUADRANTS)	0203012150200	2 Nos.	47664
2	INNER TOP COVER	0203012150300	2 Nos.	39388

Remark-

1. S.R. IS IN SCOPE OF BHEL.
2. CLEANING & NDT AFTER S.R. (AT BHEL WORKS) IS IN SCOPE OF VENDOR.
3. PAINTING IS IN SCOPE OF BHEL.
4. JOB SHALL BE CLEARED IN CONTROL MARKING, POST CONTROL MARKING DEFECTS/DEFORMATION SHALL BE ATTENDED BY VENDOR WITHIN 7 DAYS OF INTIMATION OF PROBLEM.
5. T.R. OF THE DRAWINGS ARE TO BE STRICTLY FOLLOWED.

For SL NO 1 (OUTER TOP COVER)

ASSLY & WELDING OF ITEM NO. 10 (SS PLATE LINER) INCLUDING RAW MATERIAL IS IN SCOPE OF BHEL

For SL NO 2 (INNER TOP COVER)

ASSLY & WELDING OF ITEM NO. 18, 23 & 25 (SS PLATE LINER) INCLUDING RAW MATERIAL IS IN SCOPE OF BHEL.

- **TOTAL LOAD FOR THE Enquiry (Approximately) = 174.104 MT**
- The rate (s) should be quoted in Rupees/Kg. Item wise rates for all the items covered in this particular enquiry to be quoted.
- Only BHEL/LLOYD approved qualified welders/machinist must be employed on the job.
- Only BHEL approved Brands of Electrodes / consumables/Tools to be used.
- Any assembly, welding & NDT work as per drg/QP, if reqd. after SR/SB including customer clearance shall be done by supplier at BHEL.
- S/R, S/B before final Assembly, if reqd., will be done at BHEL.
- Cleaning of parts, removal of mill scale from components prior to assembly will be in scope of vendor.
- CHP Clearance may be obtained from NTPC/LLOYD/RITES/NPC at party's end.
- Final Assembly shall undergo cleaning to ensure that all parts are free from dents, mills, spatters.
- Customer's seal (if Any on supplied Material) to be transferred.
- Copies of the relevant certificates to be supplied to the receiving shop.
- Quality plan (if any) to be followed for Material induction and CHP.

- All special tests viz., UT, RT, HYDRAULIC & KEROSENE etc. are to be performed as per drg. requirements.
- Aesthetic appearance shall also be ensured and inspected before delivery to BHEL.

2. VALIDITY: -

The validity of offers by vendors should be at least for a period of **90 days for this enquiry from the date of enquiry opening.**

3. SUBMISSION OF OFFERS: -

The offer is to be submitted in **two parts** on NIC portal only on website: <https://eprocurebhel.co.in/nicgep/app>

BHEL reserves the right to reject any or all the tenders either in full or part thereof without assigning any reasons thereof.

4. DELIVERY: -

F.O.R.: HEEP, BHEL Haridwar.

5. DELIVERY SCHEDULE: -

Sl. No.	Item Description	Drg. No.	Qty.	Delivery
1	OUTER TOP COVER (INQUADRANTS)	0203012150200	2 No.	Within 75 days from last BHEL material sent
2	INNER TOP COVER	0203012150300	2 No.	Within 75 days from last BHEL material sent

- **If material of both the quantities (2 nos.) of each item above is sent together then a grace period of 15 days will be given on second quantity of that item.**

Note: - In case the delivery offered by any vendor is more than above mentioned Delivery days from Last Material Sent from BHEL to Vendor, loading shall be done @ 0.5% per week on the rate quoted by the vendor.

- 6. Bank Guarantee/Indemnity Bond: - 25% Bank Guarantee and 75% Indemnity Bond for the value of materials to be given by vendor for free issue materials. On intimation from BHEL regarding BG & IB, the same shall be provided by the vendor (s) within 15 Days. If suitable BG and IB are not submitted to BHEL within 15 days of intimation, then the amount of days delayed beyond 15 days after intimation will be deducted from delivery days of that item and consequent PO amendment will be issued.**

For Example: If intimation for requirement of BG & IB of an item of a PO is given to vendor on 01.04.2022 from BHEL, then vendor should mandatorily provide required BG and IB by 15.04.2022. In case, the vendor provides the same by 30.04.2022, then the difference of 15 days (between 30.04.2022 & 15.04.2022) will be deducted from delivery days of that item and consequent PO amendment will be issued.

7. INSPECTION: -

- The inspection will be carried out by BHEL/BHEL nominated inspection agency at Party's works. All facilities and equipment's, calibrated instruments and standard gauges required for inspection shall be provided by the vendor during inspection. In some cases, inspection by customer's representatives like NTPC/RITES etc. (excluding NPC) may also be carried out at Party's works and CHP clearance may be obtained. No additional charges will be paid on this account.
- The party is to follow system for material control, if applicable, as per BHEL Quality Control system.
- Identification marks shall be punched on each item by the vendor i.e. Purchase Order No., Drawing No., IR No. etc.
- Aesthetic appearance is to be maintained as per drg. requirement.
- Inspection by BHEL/BHEL nominated inspection agency as per drawing /Standard and quality plan requirements.

- Quality plan no. QP/QA/20210560 rev 00 dated 01.04.2022 is attached, which is to be followed. for OUTER & INNER TOP COVER. And Applicable logsheets to be duly filled by the sub-contractor and submitted to BHEL.

8. GUARANTEE CERTIFICATE: -

The vendor shall warrant that the supplied fabricated assemblies comply fully with the drawings and other technical conditions. If the fabrications/items are found defective owing to faulty workmanship/incomplete work within a period of eighteen (18) months from the date of dispatch, the vendor shall make good of it/replace the same free of cost. Alternatively, the rework/replacement charges will be recovered.

9. PAYMENT TERMS: -

- 9.1 90% after acceptance & final clearance of SRIV.10% after FTS and final accountal of material.
- 9.2 No packing and forwarding charges will be paid extra.
- 9.3 In case of rejection, total cost of material will be recovered in case of BHEL Material and no labour cost will be paid.

10. LD CLAUSE: -

@ 0.5% per week subject to max 10% for the delayed portion of supply. The entry date mentioned by CISF on the challan at BHEL material gate will be taken as material receipt date.

11. GST: -

As applicable against documentary proof. Mention HSN/SAC code & applicable %age of GST.

- 11.1 The bidder to specify in their offer (part 1 bid) the category of their registration under GST like Registered, Unregistered and composite dealer.
- 11.2 The GST registration number of Bharat Heavy Electrical Ltd, Heavy Electricals Equipment Plant, Ranipur, Electricals Equipment Plant, Ranipur, Haridwar is '05AAACB4146P1ZL' with state Code as '05' and State Name as 'Uttarakhand'.
- 11.3 Please quote our GST registration number in all invoices raised for supply of goods and services under GST regime and also ensure filing of timely return and payment of tax and compliance of other applicable provisions on supplier under GST regime.

- 11.4 No GST will be reimbursed to unregistered or composite dealer. In the event, any GST is quoted by composite dealer, the same shall be added to the cost of supply in evaluating the bid.
- 11.5 Since, input credit of GST will be available to BHEL-Haridwar only after correct filing of return and payment of applicable GST by supplier, reimbursement of GST shall be made by BHEL Haridwar on matching of vendor inputs at GST portal, ensuring availability of input credit to BHEL Haridwar. Payment of GST will be made to vendor after matching of input credit and vendor to ensure submission of their invoices along with consent to accept payment of tax after such matching in all cases where bills are submitted directly to BHEL-Haridwar or through bank or under LC or through any other mode.
- 11.6 In the event of any disallowance of input credit or applicability of interest or any other financial liability arises on BHEL-Haridwar due to any default of supplier under GST, such implication shall be to supplier account.
- 11.7 In the event of any change in the status of vendor after submission of the bid but before the supply, GST applicable at the time of supply or in the bid, based on the registration status of the vendor, whichever is lower shall be payable.
- 11.8 Where ever applicable If PAN (Permanent Account Number) of the recipient is not available, income tax is deductible either at the normal rate or at the rate of 20 percent, whichever is higher as per Section 206AA of Indian Income Tax Act 1961.
- 11.9 **At present GST rate applicable for this enquiry will be 12 %.** However, it will be as applicable as per Govt. guidelines/circulars.

12. Amendment to PO: -

- In case, extra/less work is required due to change in Drawing / any deviation in fabricated weight at a later stage (duly verified by our Engineering Dept.), extra charges may be paid/deducted and purchase order will be amended.
- In case extra/less work is required due to change in Drawing/ technology / defects like laminations if any on BHEL supplied plates etc. / any deviation in fabricated weight (duly verified by WT), extra/less charges will be paid and purchase order may be amended accordingly. However, the same will not be applicable on deviation requested by vendors.
- Amendment due to changes in drg. /CBOM weight will be applicable only if changes are made before supply of material or changes which are under process is provided to vendor in writing by Engg. or AIX before supply of material by vendor.

13. Reverse Auction: -

“BHEL shall be resorting to Reverse Auction (RA) (Guidelines as available on www.bhel.com) for this tender. RA shall be conducted among the techno-commercially qualified bidders.

Price bids of all techno-commercially qualified bidders shall be opened and same shall be considered for RA. In case any bidder(s) do(es) not participate in online Reverse Auction, their sealed envelope price bid along with applicable loading, if any, shall be considered for ranking.”

Following are some guidelines:

- Start price for RA to be L1 of e-bid/ sealed envelope price bids.
- Minimum two techno-commercially qualified bidders are required to conduct RA.
- Wherever six or more techno-commercially qualified bidders are

available, RA would be conducted amongst first 50% of the bidders arranged in the order of prices from lowest to highest. Number of bidders eligible for participating in RA would be rounded off to next higher integer value if number of techno-commercially qualified bidders is odd (e.g. if 7 bids are technically qualified, then RA will be conducted amongst lowest four bidders). However, there will be no elimination of bidders who are MSE or qualifying under PPP-MII Order, 2017.

For detailed terms and conditions of RA guidelines, kindly refer www.bhel.com.

14. Following MSE conditions shall be followed: -

MSE Suppliers can avail the intended benefits only if they submit along with the offer, attested copies of either EM II certificate having deemed validity (five years from the date of issue of acknowledgement in EM II) or valid NSIC certificate or EM II certificate along with attested copy of a CA certificate (Format enclosed at annexure-1 where deemed validity of EM II certificate of five years has expired) applicable for the relevant financial year (latest audited). Date to be reckoned for determining the deemed validity will be the date of bid opening (Part 1 in case of two part bid). Non submission of such documents will lead to consideration of their bid at par with other bidders. No benefit shall be applicable for this enquiry if any deficiency in the above required documents is found or the requisite documents are not submitted before price bid opening.

* Any new supplier will be eligible for registration with BHEL as MSE supplier provided at least any one of the following documents are submitted along with application for registration: -

a. Valid NSIC Certificate or

b. Entrepreneurs' Memorandum part II (EM II) certificate (valid based on deemed validity of 5 years) or

c. EM II certificate along with attested copy of CA Certificate (as per prescribed format at annexure 1) applicable for the relevant financial year (latest audited), where the deemed validity of EM II is over. However, credentials of all MSE supplier will be verified before advancing the intended benefits.

* MSE vendors claiming SC/ST status will have to submit SC/ST certificate of the Proprietor from competent authority. Attested (notarized or attested by Gazetted officer) copy to be submitted along with the offer.

* In case techno-commercial accepted vendors include MSE source and their prices (based on landed cost to BHEL) are within the price band of 15% w.r.t. L-1 vendor, then BHEL can offer 25% of quantity of respective item (rounded off to nearest number) to MSE vendors at L-1 price and in case, more than one MSE vendor is in 15 % band and the same is accepted by more than one MSE vendors then 25% quantities of respective items will be considered for ordering on proportionate basis amongst MSE vendors.

* While distributing the 25% quantity amongst MSE vendors the decimal points in quantity shall be ignored for all the vendors except the L-1 amongst MSE vendors. Balance quantity after allocating the quantity to other MSE vendors ignoring the quantities in decimal, shall be given to L-1 (amongst MSE) vendor. However, if there are more than one MSE vendor at the same price level than preference for additional quantities due to ignoring off the decimal (as mentioned above) shall be given to the vendor offering favourable terms to BHEL and if the conditions offered are also same then preference will be given to the vendor having high SPR rating.

* In case there are more than one MSE vendors (with different landed cost to BHEL) within 15% price band of lowest bidder and quantity to be offered is 1 no. only, then preference shall be given to the MSE vendor with lowest landed cost.

* In case there are more than one MSE vendors (with same landed cost to BHEL) within 15% price band of lowest bidder and quantity to be offered is 1 no. only, then preference shall be given first, based on the favourable terms in the bid and in case terms are also same, the vendor with high SPR rating shall be given preference.

15. EVALUATION OF BIDS: Evaluation of bids will be done on item wise basis. Hence, RA will be done on item wise basis. All vendors will be assessed on total cost to BHEL basis that includes freight, taxes, ITC etc.

16. GENERAL INSTRUCTIONS: -

- 16.1 No further sub-contracting to third party or sister concern by the sub-contractor is allowed Without prior permission of BHEL. If found guilty, will be debarred.
- 16.2 BHEL reserves the right to suspend/cancel the PO/Enquiry unilaterally without any financial repercussions, if Sub-contractor's performance is not found to be satisfactory.
- 16.3 BHEL reserves the right to revise the drawing after placement of purchase order. The prices in the purchase order will be amended according to revised drawing.
- 16.4 Subsequent ordering shall be done based on performance and execution of orders in time as per PO. Delivery.
- 16.5 In the course of evaluation, if more than one bidder happens to occupy L1 status, effective L1 will be decided by soliciting discounts from respective L1 bidders. In case more than one bidder happens to occupy the L1 status even after soliciting discounts, the L1 bidder shall be decided by toss/draw of lots, in the presence of respective L1 bidder(s) or their representative(s). Ranking will be done accordingly. BHEL's decision in such situation shall be final and binding.
- 16.6 Vendor must fill in the rate per Kg. in Annexure-A and put in the Price Bid envelop.
- 16.7 EMD submission may be waived for Central/State-PSUs/Government departments.
- 16.8 MSE suppliers are exempted for submission of EMD & Tender Fee.
- 16.9 As per the Office Memorandum F.No. 1(2)(1)/2016-MA dated 09.02.2017 issued from the office of Development Commissioner (micro, small & medium enterprises), "Traders and agents should not be allowed to avail the benefits extended under the pp policy." in view of this, it is clarified that benefits of MSE (such as EMD waiver, tender fee exemption, price preference, payment preference etc.) will be given only to those MSE vendors who are manufacturers of offered items against the NIT. No MSE benefits shall be provided to agents / stockists / dealers / traders etc.
- 16.9.1 Open tender is hoisted on the <https://eprocurebhel.co.in/nicgep/app> and no hard copy of document is provided by BHEL, no tender fee shall be insisted upon from the bidders.
- 16.10 Central / State – PSUs / Government departments are exempted from submission of EMD subject to approval by BHEL management.
- 16.11 Please refer **GENERAL INSTRUCTIONS AND STANDARD TERMS & CONDITIONS (Version: June-2021, Rev.06)** for bidding against tender enquiry. The bidder/vendor must ensure compliance of these GISTC (Version: June-2021, Rev.06).
- 16.12 **Documents submitted with the offer/bid by the bidder shall be signed and stamped in each**

- page by authorized representative of the bidder.**
- 16.13 **PQR uploaded with the tender document is to be submitted along with the Techno-Commercial offer (PART-I).**
Note :- Offer shall be entertained only after submission of duly filled, signed and stamped PQR and relevant documents. Offers of the vendor(s) not submitting this Annexure may be ignored.
The evaluation currency shall be INR (Indian Rupee).
- 16.14 The Bidder declares that they will not enter into any illegal or undisclosed agreement or understanding, whether formal or informal with other Bidder(s). This applies in particular to prices, specifications, certifications, subsidiary contracts, submission or non-submission of bids or any other actions to restrict competitiveness or to introduce cartelization in the bidding-process.
In case, the Bidder is found having indulged in above activities, suitable action shall be taken by BHEL as per extant policies/ guidelines.
- 16.15 For this procurement, Public procurement (preference to Make in India), Order 2017 dated 04.06.2020 shall be applicable.
For this procurement, the local content to categorize a supplier as Class-I local supplier/ Class II local supplier/Non-local supplier and purchase preference to Class I local supplier, is as defined in Public procurement (preference to Make in India), Order 2017 dated 04.06.2020 issued by DPIIT. In case of subsequent orders issued by the nodal ministry, changing the definition of local content for the items of NIT, the same shall be applicable even if issued after issue of this NIT, but before opening of part-II bids against this NIT.
As defined under public procurement (Make in INDIA) notification dated 04.06.2020, only the 'Class-I local supplier' and 'Class-II local supplier' are eligible to bid against this enquiry. Hence bids of non-local supplier (if any) will not be considered.
Accordingly, the 'Class-I local supplier' / 'Class-II local supplier' at the time of tender, bidding or solicitation shall be required to indicate the percentage of local content and provide self-certification that the item offered meets the local content requirement for 'Class-I local supplier' / 'Class-II local supplier' and shall give details of the location(s) at which the local value addition is made.
Procurements where the Estimated value to be procured is less than Rs. 5 lakhs shall be exempted from Public Procurement (Preference to Make in India) Order 2017 dated 04.06.2020.
- 16.16 Vendor Contract clause regarding GST ITC and provision for E-Invoices:
(i) E-Invoicing under GST is being implemented w.e.f. 01.10.2020 for all the taxable persons having turnover more than Rs. 20 Cr. It has been specified by the Govt. that it is mandatory to mention a valid unique Invoice Reference No. (IRN) and QR code as generated from Govt. portal on a Tax Invoice. Based on such information, GST ITC as claimed by BHEL in GST Returns shall be matched with the corresponding details uploaded by supplier in E-Invoicing System.
(ii) In case the vendor /contractor delays or fails to provide all the documents as per the Purchase order / Work Order at the time of submitting Tax invoice to BHEL, any subsequent financial loss to BHEL on account of vendor/contractor shall be to vendor's / contractor's account. BHEL has further right to take necessary steps to protect its interest at the time of release of payment. This further requires inclusion of IRN and QR code on tax invoice as announced by Govt. of India w.e.f. 01.10.2020.
- 16.17 **Bidder to necessarily submit duly filled in, signed and stamped Anexures** (attached alongwith the tender document).

- 16.18 In case of ordering against the tender, vendor should submit their invoices against goods and services immediately after supply of goods & services but not later than 30 days from the invoice date. In case of delay, consequential losses like loss of input credit and non-availability of concessional forms etc. shall be to the vendor account.
- 16.19 The bidders against open tender will necessarily have to obtain class – III DSCs. Procedure for application is available on www.bhel.com.
- 16.20 **RECTIFICATION:** - Any defect (noticed at Shop) arising out of the fabrication/machining done by the Sub-Contractor, will have to be rectified or items replaced by the sub-contractor within 10 days at their own cost. Otherwise BHEL will be free to take necessary action as deemed fit and consequence/cost of the same will be to subcontractors-account.

17. Transportation: -

BHEL will send raw material to vendor works on freight paid basis and vendor to deliver fabricated/machined items to BHEL Haridwar at their own cost. The loading for sending raw material for each item will be part of RA sheet provided to techno-commercially qualified bidders at the time of Reverse auction based on their location.

18. SCRAP: -

- Generated scrap is to be retained by the sub-contractor. This scrap is chargeable. The scrap rate will be calculated based on the monthly market scrap price Published in MSTC Bulletin/any other document under category of scrap MELTING SCRAP. The calculated monthly price for charging scrap will be rounded off to two decimal places of Rupee. GST charges on scrap shall also be applicable.
- BHEL would recover the amount of GST and Trade Tax as applicable from the sub-contractor's account in lieu of scrap retained by them. The difference between raw material weight and finalized weight shall be considered for the calculation of scrap generation.
- A 3% invisible cutting allowance may be given on the finished weight.

19. OPTION CLAUSE: The Purchaser reserves the right to increase or decrease the quantity to be ordered up to 25 percent of bid quantity at the time of placement of contract. The purchaser also reserves the right to increase/ decrease the ordered quantity by up to 25% of the contracted quantity during the currency of the contract at the contracted rates. Bidders are bound to accept the orders accordingly.

20. Integrity Pact: Supplier must submit Integrity Pact duly signed and stamped along with this offer as per attached annexure.

21. PRICE VARIATION CLAUSE: - No PVC is applicable for this enquiry.

Against vendor's replies, BHEL reserves the right to ask for more information/ documents / clarifications. Vendor's offer shall not be considered if vendor fails to furnish the document / information / clarifications as mentioned above or doesn't meet the acceptance criteria.

Amendments/Corrigendum, if any, will be hosted on <https://eprocurebhel.co.in/nicgep/app> only. Other terms and conditions will be as per tender documents.

Any vendor who is under hold (for the item)/ delisted/ banned with BHEL on date of opening of Part – 1 will not be allowed to quote for this tender. In case their offer is received, it may be outrightly rejected.

In view of Covid-19 and present situation the Tender Document, Drawings, P.O copy etc. shall be sent by e-mails and shall not be sent in hard copies. Vendors to kindly note that the details sent by e-mail shall be considered for delivery against the finalized contract(s)/ P.O's placed .

KINDLY READ "TERMS & CONDITIONS FOR PRE-FAB. M/C & FAB. ONLY OF Inner Top Cover, Outer Top Cover". QUOTATION NOT IN ACCORDANCE WITH THE INSTRUCTIONS ARE LIABLE TO BE DISQUALIFIED AND IGNORED. Kindly submit Checklist of T&C of this enquiry attached with tender document.

Annexure - A

PRE-FAB. M/C & FAB. ONLY OF Inner Top Cover, Outer Top Cover.

OpenTender Enquiry No.: X/6620/2021/0560/E/1

Sl. No.	Item Description	MATERIAL BY	RATE (Rs. PER Kg.)
1	OUTER TOP COVER(INQUADRANTS)	BHEL MATERIAL (BM)	
2	INNER TOP COVER	BHEL MATERIAL (BM)	

Authorised Signature:
(with date & seal of company)

Name of Supplier: -

TERMS AND CONDITIONS FOR Enquiry No.X/6620/2021/0560/E/1



SL.	TERMS	VENDOR'S ACCEPTANCE/ REMARKS
1	Scope of Work: - Complete Fabrication & machining is to be carried out by the vendor as per Drawing/Standard, QP and Technical requirements as per clause 1 of terms & conditions.	
2	Quotation is valid for a minimum period of 90 days from date of opening of enquiry. (clause no. 2.0 of Terms and Conditions)	
3	Submission of offers (clause no. 3.0 of Terms and Conditions)	
4	Quoted rates are on F.O.R. sub-contract store, HEEP, Haridwar basis.(clause no. 4.0 of Terms and Conditions)	
5	Delivery schedule: Item wise as per clause 5 of T& C of enquiry	
6	Bank Guarantee/Indemnity Bond: 25% BG & 75% Indemnity bond as per clause 6 of T& C of enquiry	
7	Inspection shall be done as per clause no. 7 of Terms and Conditions of Enquiry	
8	Guarantee Certificate shall be valid for 18 months from receipt of material in BHEL as per clause no. 8 of Terms and Conditions of Enquiry	
9	90% after acceptance & final clearance of SRIV.10% after FTS and final accountal of material as per clause no. 9 of Terms and Conditions of Enquiry.	
10	LD clause is applicable@0.5% per week or part thereof with a maximum limit of 10% of the delayed portion of the PO as per clause no. 10 of Terms and Conditions of Enquiry.	
11	GST shall be applicable against documentary proof. Input Tax Credit shall be applicable and BHEL can claim benefit as per clause 10. of T & C of enquiry as per clause no. 11 of Terms and Conditions of Enquiry.	
12	Amendments of PO rates as per clause no. 12 of Terms and Conditions of Enquiry.	
13	We accept Reverse Auction(RA) clause as per standard policy of BHEL as per clause no. 13 of Terms and Conditions of Enquiry.	
14	We are MSME vendor and have submit UDYAM certificate(Non MSME vendor to write NA) as per clause no. 14 of Terms and Conditions of Enquiry.	
15	Evaluation of bids as per clause no. 15 of Terms and Conditions of Enquiry.	
16	We have read clause no. 16 of terms and conditions of Enquiry and confirm to abide the same.(Clause 16.1 to 16.20)	
17	Transportation:Confirm acceptance of clause 17 of T & C.Manufactured items shall be despatched by BHEL approved transporter only and Insurance shall be borne by BHEL.	
18	Scrap :Conifrm acceptance of Clause 18 of T & C of Enq.	
19	Option Clause: Confirm acceptance of clause 19 of T&C of enquiry.	
20	Signed and stamped Integrity pact is attached alongwith	
21	Price Variation clause (PVC) is not applicable.	
22	We accept Risk Purchase clause as per standard policy of BHEL.	
23	We have submitted Make in India certificate (duly filled and signed as per Annexure-II).	
24	Rates have been quoted in indian Rupees on per Kilo Gram basis.	

Note: BHEL reserves the right to reject any or all the offers (on techno-commercial ground) without assigning any reason thereof.

(Vendor's signature with Stamp)

Manufacturer Name and Address BHEL Haridwar accepted / approved sub-contractors only	MANUFACTURING QUALITY PLAN							APPLICABILITIES TO					
	ITEM	INNER TOP COVER, OUTER TOP COVER					Q.P. NO	QP/QA/20210560	PROJECT		KALESHWARAM		
	WO. No.	20282T20201, 20283T20201					DATE	01.04.2022	CONTRACTOR		BHEL (HEEP) HWR		
							REV. NO.	00	Indent		202100560 rev 00 dated 30.03.2022		
							PAGE NO.	Page 1 of 2					

S. No.	COMPONENT OPERATION	CHARACTRISTIC CHECKED	CATE-GORY	TYPE/ METHED OF CHECKED	QUANT-UM OF CHECK	REFERENCE DOCUMENT	ACCEPTANCE DOCUMENT	FORMAT OF RECORD					REMARK
									D	M	B	C	
1	2	3	4	5	6	7	8	9	10	11	12	13	14
1.0	Material Receiving Inspection	Review of Supplier Test Certificate of Material for all the party materials	Major	Visual inspection	100 %	As per drg./ Standard	As per drg./ Standard	TC	✓	P	V	-	For BHEL material, transfer of identification to be ensured
2.0	<u>INPROCESS-INSPECTION</u>												
2.1	Pre-fabrication machining of individual components	Dimensions	Major	Measurement	100%	BHEL drawing	BHEL drawing	Dimensional report	✓	P	V	-	
2.2	WPS, PQR & WPQ Qualification	Scrutinizing	Major	Record check	100%	ASME SEC IX	ASME SEC IX	Test Report	✓	P	V	-	WPS/PQR/WPQ approved by BHEL/BHEL approved agency shall be used.
2.3	Welding Operation	i) Visual inspection of welds	Major	Visual	100%	As per drg./ Standard	As per drg./ Standard	Obs. sheet	✓	P	V	-	1) BHEL approved electrode shall be used during welding 2) Qualified welders by BHEL /BHEL approved agency in accordance with ASME Section IX will be deployed on the job



Manufacturer/Subcontractor	Legends: P Perform by; W Witness by; V Record review; C Customer ; B BHEL/BHEL Representative; M Manufacturer/ sub-contractor; D: documents with tick mark shall be submitted by vendor to BHEL.	For BHEL Use	
		Worked by:  Sugandh Agarwal (QAX-Mfg)	Approved by:  Sunil Pandey, Manager (QA)

Manufacturer Name and Address	MANUFACTURING QUALITY PLAN				APPLICABILITIES TO		
	BHEL Haridwar accepted / approved sub-contractors only	ITEM	INNER TOP COVER, OUTER TOP COVER		Q.P. NO	QP/QA/20210560	PROJECT
WO. No.		20282T20201, 20283T20201		DATE	01.04.2022		
				REV. NO.	00	CONTRACTOR	BHEL (HEEP) HWR
				PAGE NO.	Page 2 of 2	Indent	202100560 rev 00 dated 30.03.2022

2.4		ii) NDT of welds.	Major	NDT	As per drg.	As per drg./ Standard	As per drg./ Standard	Report	✓	P	V / W	-	1) NDT shall be carried out by ASNT/ISNT Level I/II Qualified Operators 2) V in case of RT' W in case of UT/DPT/MPI. 3) NDT consumables shall be procured from BHEL approved sources.
3.0	FINAL INSPECTION												
3.1	Dimensions	Verification of dimension & visual inspection after cleaning	Major	Visual & measurement	100%	As per drg./ Standard	As per drg./ Standard	Obs. Sheet / LOGSHEET	✓	P	W	-	
3.2		Completeness of Job, Documentation	Major	Visual	100%	As per drg./ Standard	As per drg./ Standard	Record	✓	P	V	-	Item shall be dispatched to BHEL after acceptance by BHEL/ BHEL nominated agency after duly identifying by P.O.No., drg no. Plant Order No. and I.R.No

Note:

1. Requirements of P.O., drawing and standard shall be fulfilled.
2. BHEL reserves the right for conduct repeat test, if required.

Manufacturer/Subcontractor	Legends: P Perform by; W Witness by; V Record review; C Customer ; B BHEL/BHEL Representative; M Manufacturer/ sub-contractor; D: documents with tick mark shall be submitted by vendor to BHEL.	For BHEL Use	
		Worked by:  Sugandh Agarwal (QAX-Mfg)	Approved by:  Sunil Pandey, Manager (QA)



HARIDWAR

LOGSHEET MANUFACTURING HEEP-HARIDWAR

DIMENSIONAL INSPECTION REPORT

PROJECT : KALESHWARAM PROJECT LINK-II PACKAGE-II WORK ORDER No.	TYPE/RATING: 4X130 MW SINGLE STAGE VERTICAL PUMP
DESCRIPTION : OUTER TOP COVER	CONTRACTOR : MEIL, HYDERABAD
DRAWING NO. 02030121502 (BHOPAL REF. DRG. NO. 02030118402)	LOGSHEET NO. 02030121502 LS
ASSY. DRG.- 02030121501	

OPN./ SL. No.	DRG. SIZE	ACTUAL SIZE	REMARKS
I/D	(D1)	Ø5184(+1.0)	
O/D	(D2)	Ø7100(-2.0)	
O/D	(D3)	Ø 6650(-2.0)	
I/D	(D4)	Ø 5174 (+0.5)	
I/D	(D5)	Ø 5082 (+0.5)	
O/D	(D6)	Ø 6510 (-1.0)	
I/D	(D7)	Ø 5730(-0.3)	SEAL RETAINER FITMENT
O/D	(D8)	Ø 5960 (+0.3)	SEAL RETAINER FITMENT
O/D	(D9)	Ø 6650(-1.0)	
WIDTH	(W1)	18(-0.5)	
DEPTH	(T1)	10.5 (+/-0.1)	
Ht.	(H1)	821 (+0.2/+0.5)	
Ht.	(H2)	699.5 (-0.1/-0.3)	
T. Ht.	(H3)	795.5 (+0.15)	
		100 HOLES EQUISPACED ON-CENTRE DRILL THRO Ø 107 ON PCD 6860	
		20 HOLES EQUISPACED DRILL THRO AND TAP M48 X 5P (5 IN EACH QUADRANT) ON PCD 6860	
		16 PILOT HOLES (4 IN EACH QUADRANT) EQUISPACED DRILL THRO Ø 16 ON PCD 6860	FOR DOWELLING WITH STAY RING
		16 HOLES M64 X 4P (4 IN EACH QUADRANT) ON PCD 6560	

NOTE: ALL DIMENSIONS ARE IN mm

ISSUING DEPT.	NAME	SIGN	DATE		INSPECTED BY:-
PREPARED BY:-	PS	sd/-	05/08/21		FILLED IN BY :-
CHECKED BY:-	PS	sd/-	09/08/21	REV. DATE	CHECKED BY :-
APPROVED BY:-	DS	sd/-	09/08/21	REV. DATE	APPROVED BY :-



HARIDWAR

LOGSHEET MANUFACTURING HEEP-HARIDWAR

DIMENSIONAL INSPECTION REPORT

PROJECT : KALESHWARAM PROJECT LINK-II PACKAGE-II WORK ORDER No.	TYPE/RATING: 4X130 MW SINGLE STAGE VERTICAL PUMP
DESCRIPTION : INNER TOP COVER	CONTRACTOR : MEIL, HYDERABAD
DRAWING NO. 02030121503 (BHOPAL REF. DRG. NO. 02030118403)	LOGSHEET NO. 02030121503 LS
ASSY. DRG.- 02030121501	ALL DIMENSIONS ARE IN mm

OPN./ SL. No.	DRG. SIZE	ACTUAL SIZE	REMARKS
O/D	(D1)	Ø3816(-0.1/-0.2)	
O/D	(D2)	Ø5480(-1.0/-0.5)	
O/D	(D3)	Ø 5180 (-1.0)	
O/D	(D4)	Ø 5172 (-0.5)	
I/D	(D5)	Ø 4970	
I/D	(D6)	Ø 1486 (+0.2)	
I/D	(D7)	Ø 2100 (+1.0)	
O/D	(D8)	Ø 3894 (+0.25)	UPPER ST. LABY.
I/D	(D9)	Ø 3806 (-0.25)	UPPER ST. LABY.
WIDTH	(W1)	15(+0.5)	
DEPTH	(T1)	9(+/-0.1)	
HEIGHT	(H1)	853(+0.1/+0.3)	
HEIGHT	(H2)	723(+0.1/+0.3)	
HEIGHT	(H3)	821(-0.2/-0.4)	
HEIGHT	(H4)	115 (+0.2)	UPPER ST. LABY.
		48 NOS TAPPED HOLES EQUISPACED OFF CNTR OF SIZE M 24 X 3 P ON PCD 3700	
		48 TAPPED HOLES M 36 X 4P EQUISPACED OFF CNTR ON PCD 2300	
		80 HOLES EQUISPACED OFF CNTR DRILL THRO Ø86 ON PCD 5340	
		8 HOLES DRILL THRO & TAP M 36 X 4P ON PCD 5340 FOR JACKING	
		32 HOLES EQUISPACED DRILL THRO & TAP M30 X 3.5 P ON PCD 1730	
		4 HOLES DRILL THRO Ø20 ON UPPER ST. LABY. ON PCD 3808 & 3892 FOR LABYRINTH CLEARANCE MEASUREMENT	

ISSUING DEPT.	NAME	SIGN	DATE		INSPECTED BY:-
PREPARED BY:-	PS	sd/-	05/08/21		FILLED IN BY :-
CHECKED BY:-	PS	sd/-	09/08/21	REV. DATE	CHECKED BY :-
APPROVED BY:-	DS	sd/-	09/08/21	REV. DATE	APPROVED BY :-

DRG. NO. 0 20301 21503

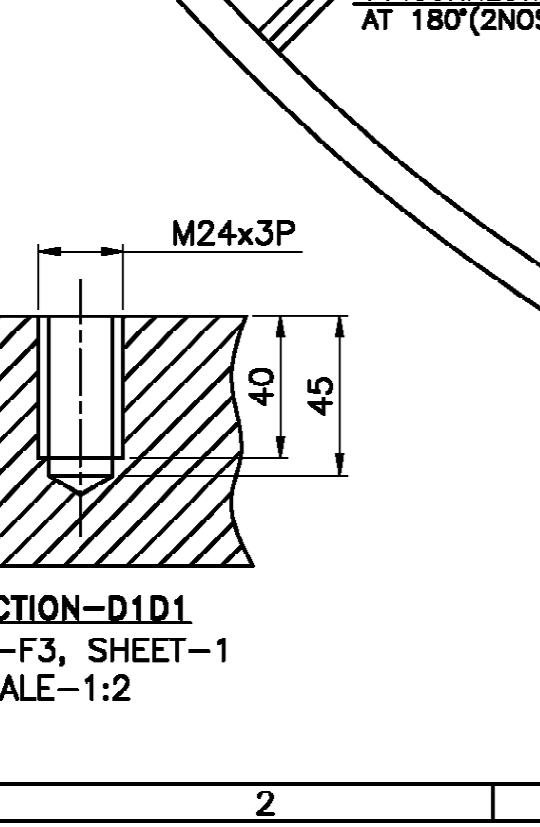
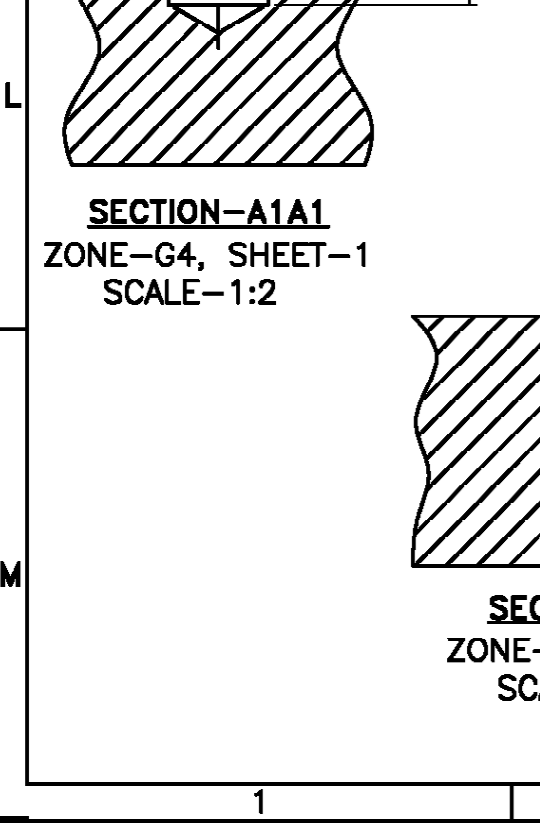
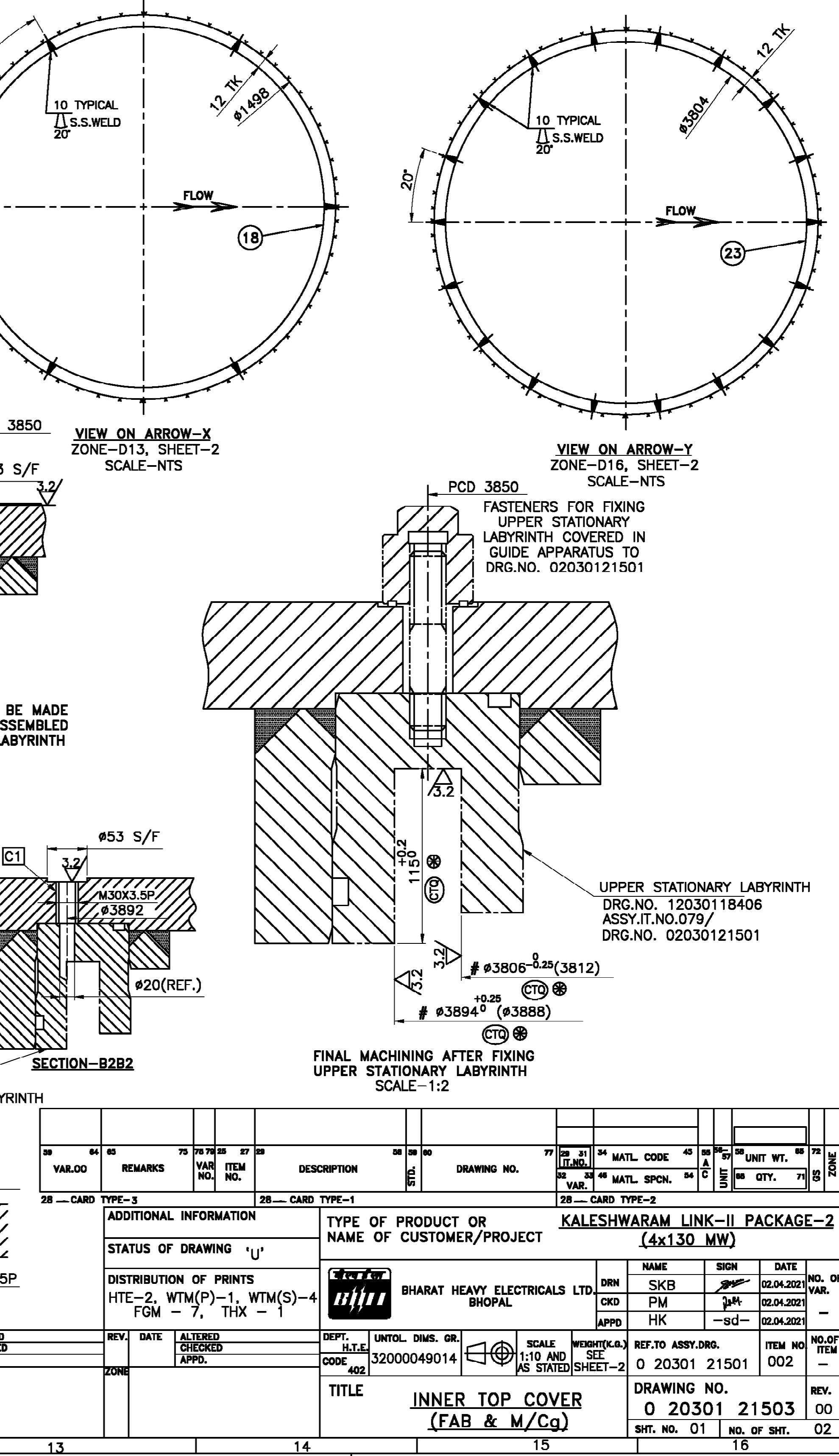
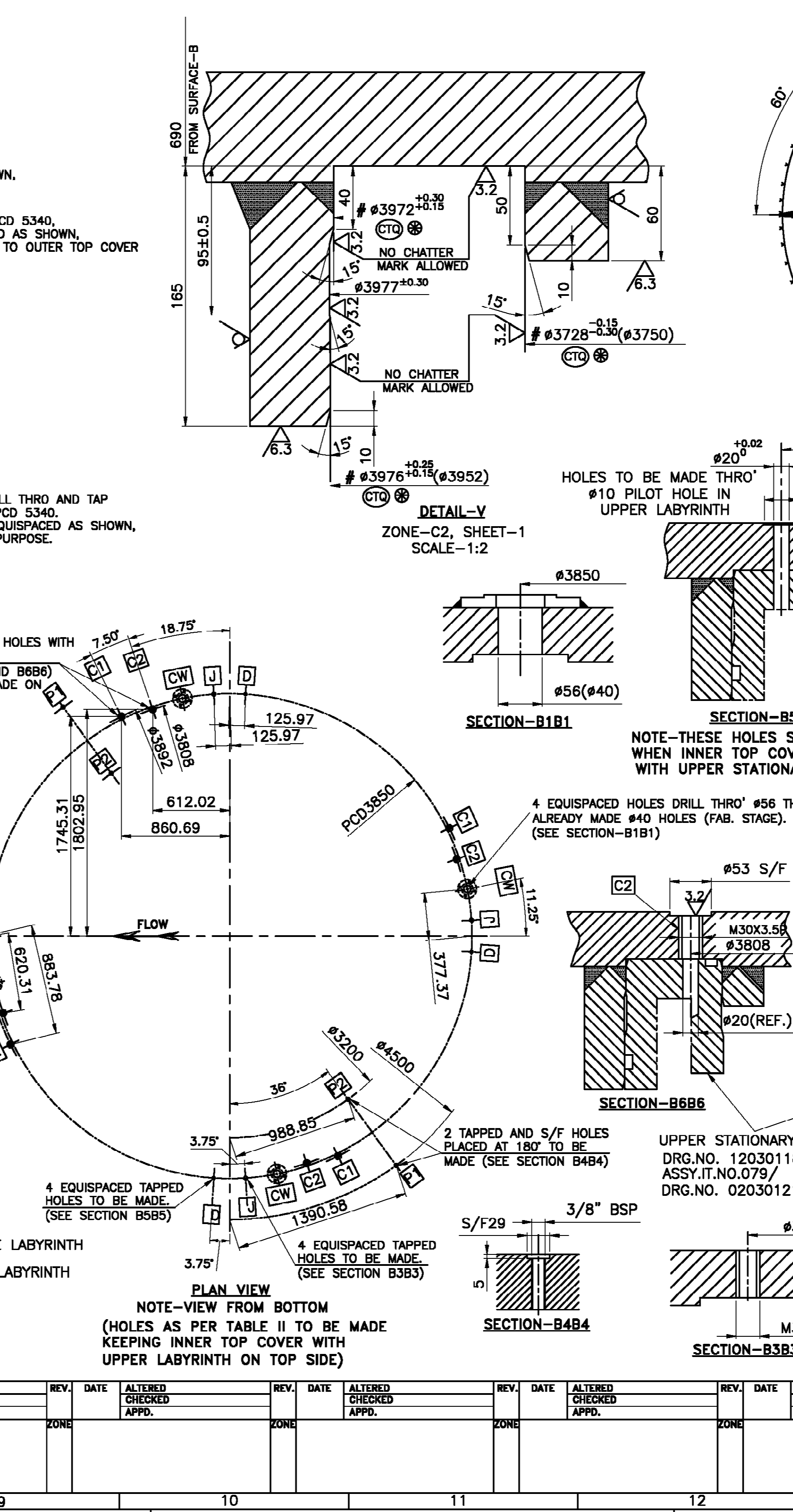
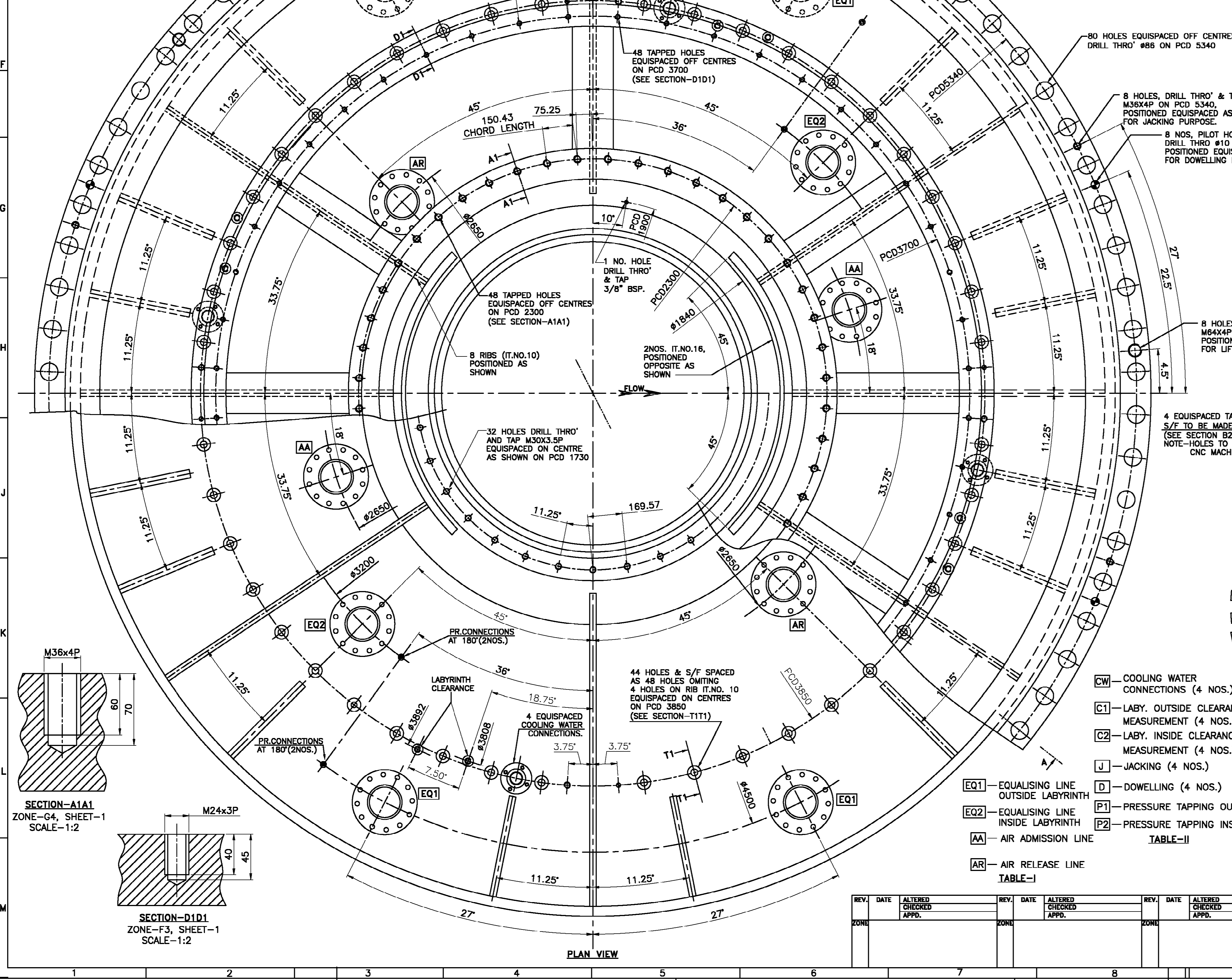
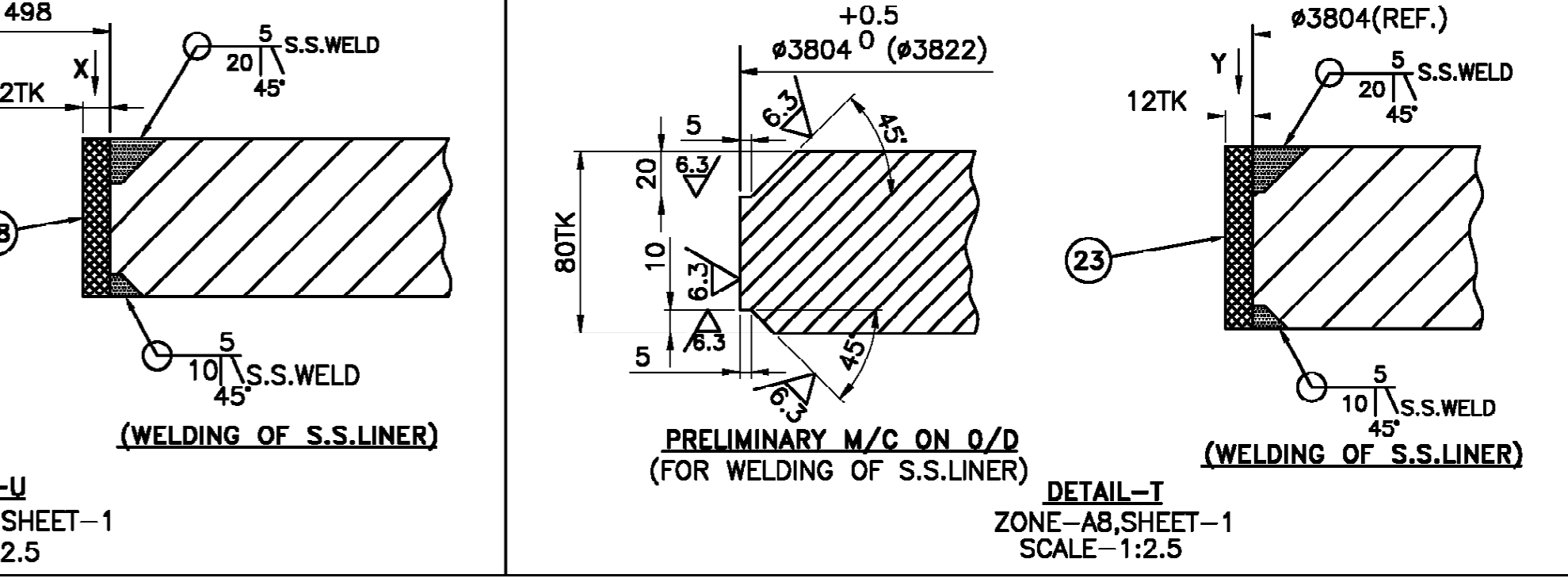
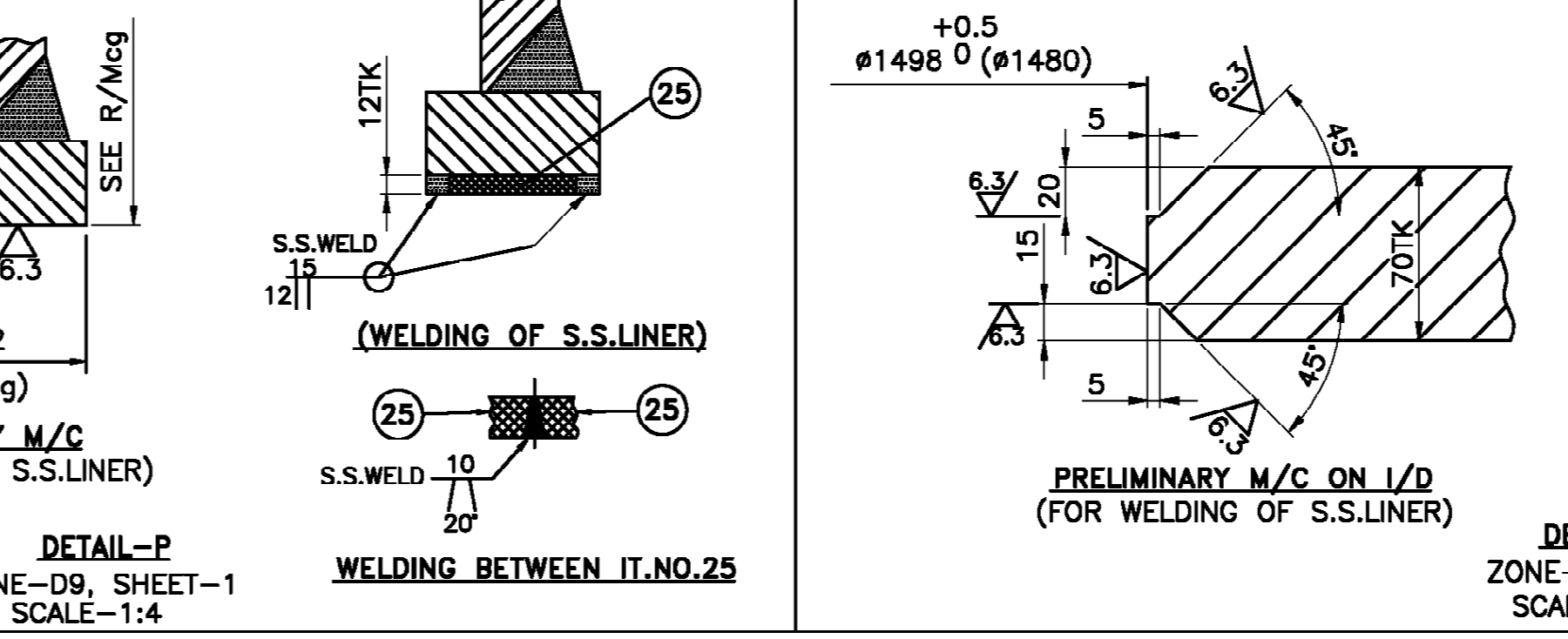
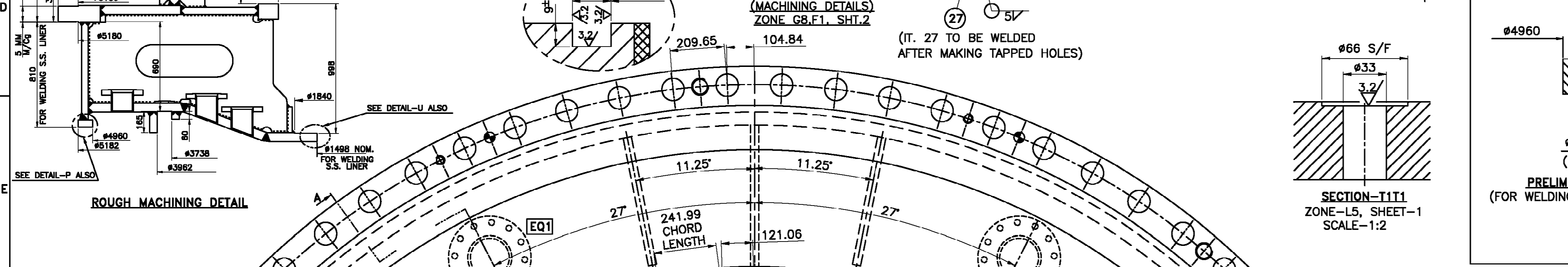
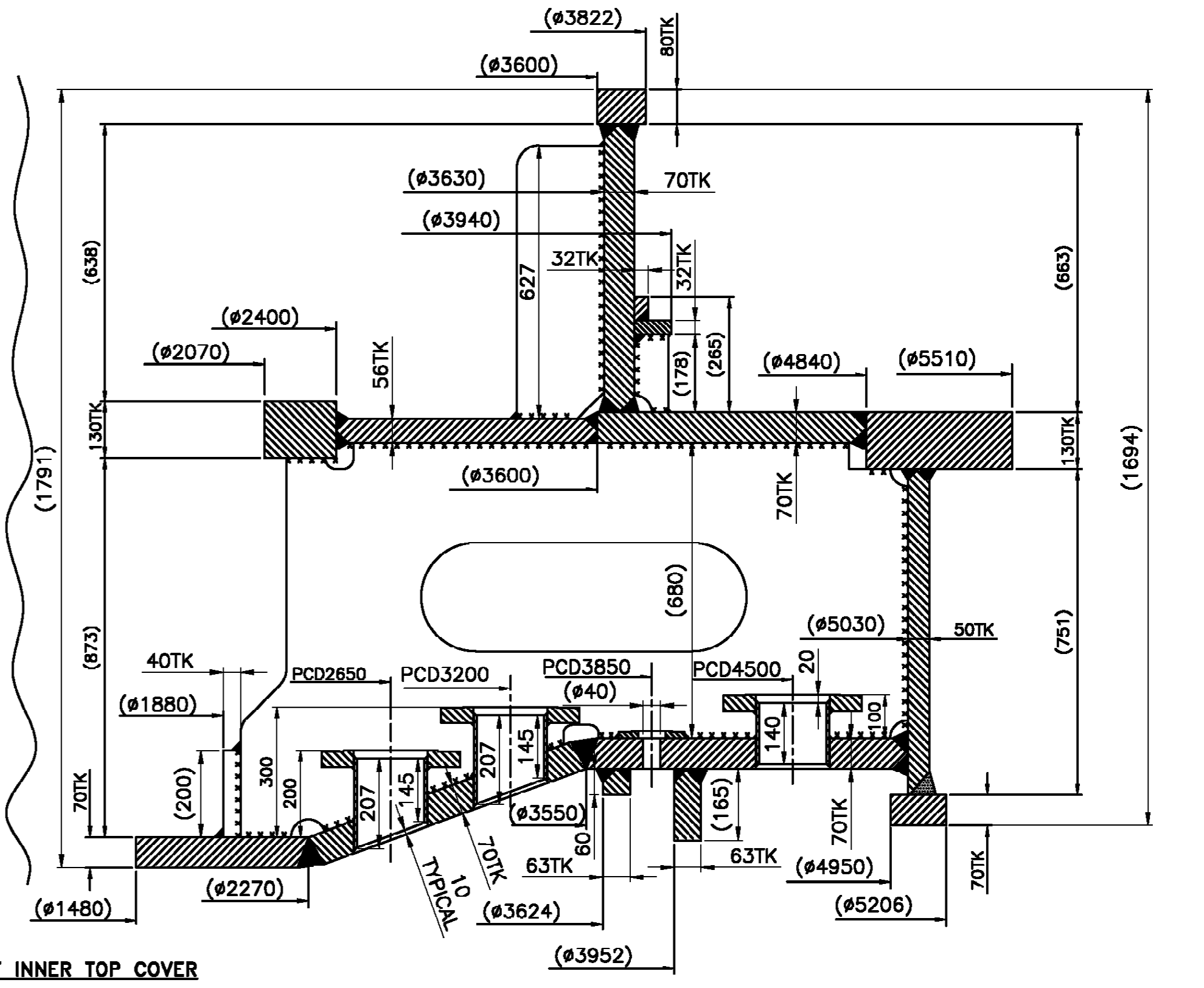
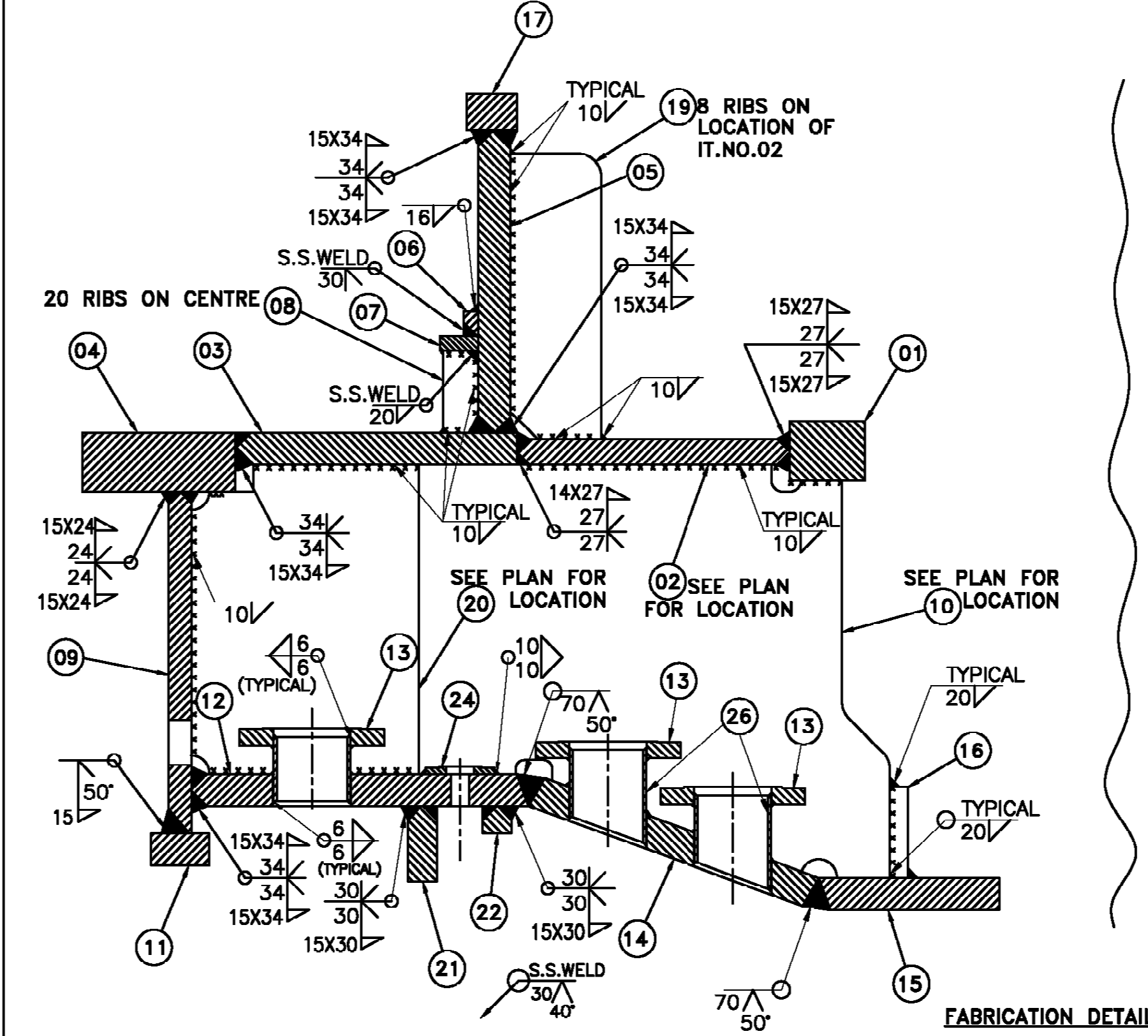
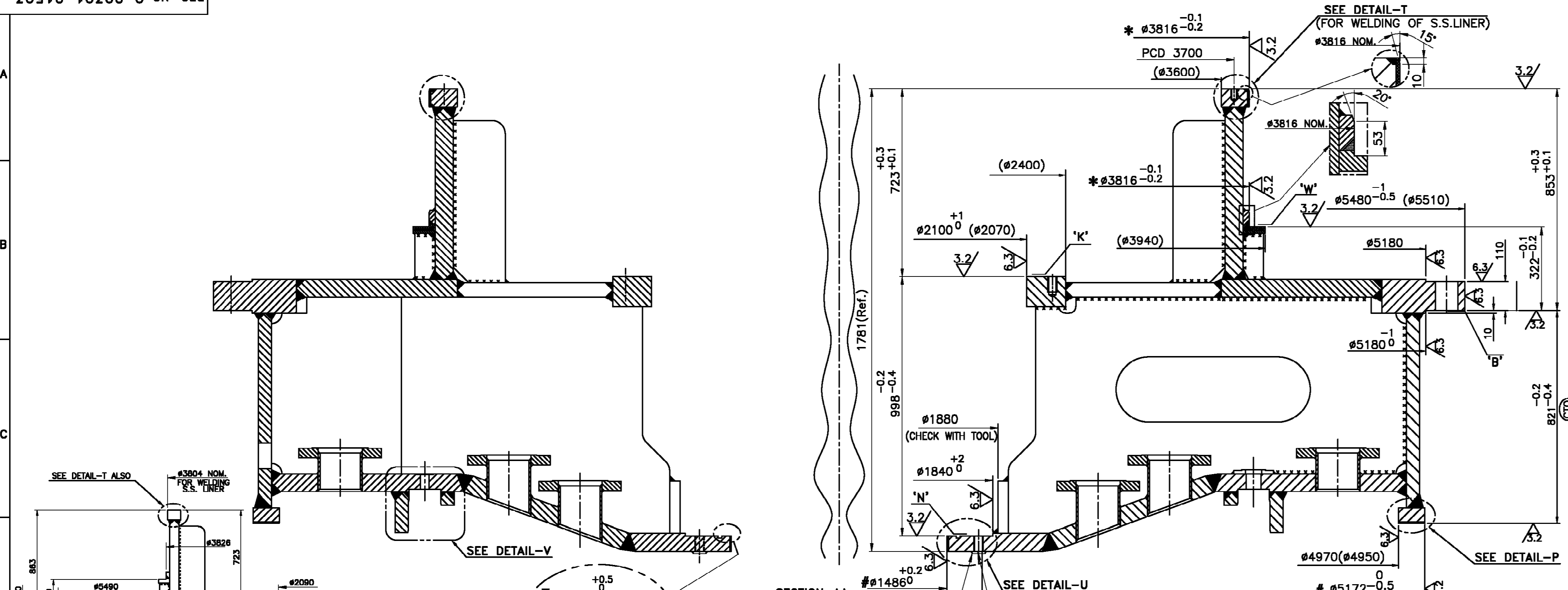
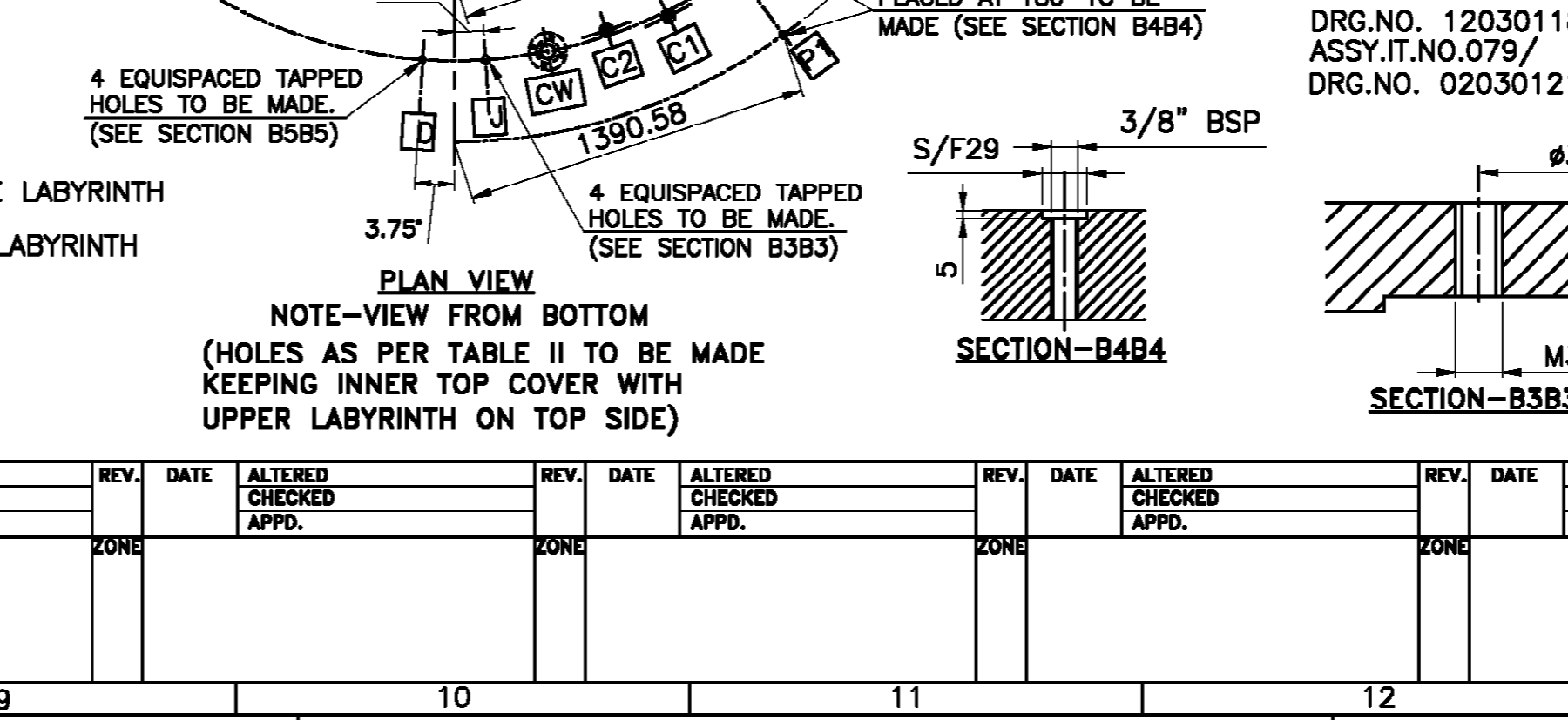

TABLE-I

CW	COOLING WATER CONNECTIONS (4 NOS.)
C1	LABY. OUTSIDE CLEARANCE MEASUREMENT (4 NOS.)
C2	LABY. INSIDE CLEARANCE MEASUREMENT (4 NOS.)
J	JACKING (4 NOS.)
EQ1	EQUALISING LINE OUTSIDE LABYRINTH
EQ2	EQUALISING LINE INSIDE LABYRINTH
AA	AIR ADMISION LINE
AR	AIR RELEASE LINE

TABLE-II

D	DOWELLING (4 NOS.)
P1	PRESSURE TAPPING OUTSIDE LABYRINTH
P2	PRESSURE TAPPING INSIDE LABYRINTH



UPPER STATIONARY LABYRINTH DRG. NO. 12030118406 ASSY. IT. NO. 079 / DRG. NO. 02030121501

FASTENERS FOR FIXING UPPER STATIONARY LABYRINTH COVERED IN GUIDE APPARATUS TO DRG. NO. 02030121501

FINAL MACHINING AFTER FIXING UPPER STATIONARY LABYRINTH SCALE-1:2

REV.	DATE	ALTERED BY	CHECKED BY	APPROVED BY	REV.	DATE	ALTERED BY	CHECKED BY	APPROVED BY	REV.	DATE	ALTERED BY	CHECKED BY	APPROVED BY	REV.	DATE	ALTERED BY	CHECKED BY	APPROVED BY

STATUS OF DRAWING 'U'

DISTRIBUTION OF PRINTS
HTE-2, WTM(P)-1, WTM(S)-4
FGM - 7, THX - 1

ADDITIONAL INFORMATION

TYPE OF PRODUCT OR NAME OF CUSTOMER/PROJECT
KALESHWAR LINK-II PACKAGE-2 (4x130 MW)

DEPT. / UNTO. / DMS. / DR. / SCALE / HSE/HTK-A-K
32000049014 / 1:10 AND 1:5 / AS STATED

REF. TO ASSY. DRG. / NO. OF SHEETS / NO. OF ITEMS
0 20301 21501 / 002 / -

TITLE
INNER TOP COVER (FAB & M/Cg)

DRAWING NO.
0 20301 21503

REV. NO. / NO. OF SHEETS
01 / 02

THE INFORMATION ON THIS DOCUMENT IS THE PROPERTY OF BHARAT HEAVY ELECTRICALS LIMITED. IT MUST NOT BE USED DIRECTLY OR INDIRECTLY IN ANY WAY DETRIMENTAL TO THE INTEREST OF THE COMPANY.

FIRST ANGLE PROJECTION

(ALL DIMENSIONS ARE IN mm)

DRG. NO. 3-203-01-18416

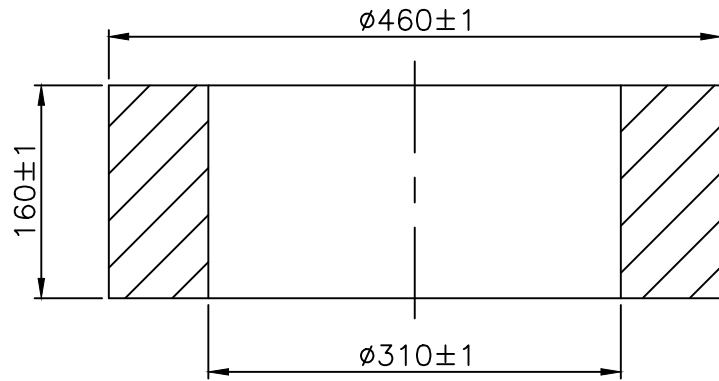

SECTION-AA

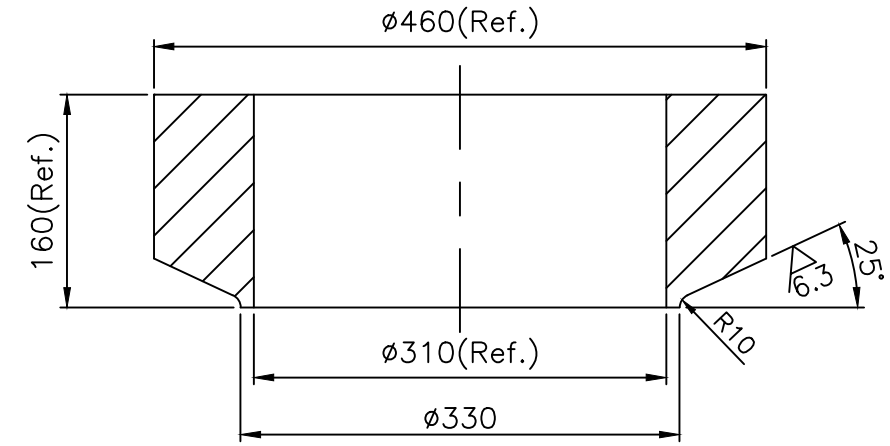
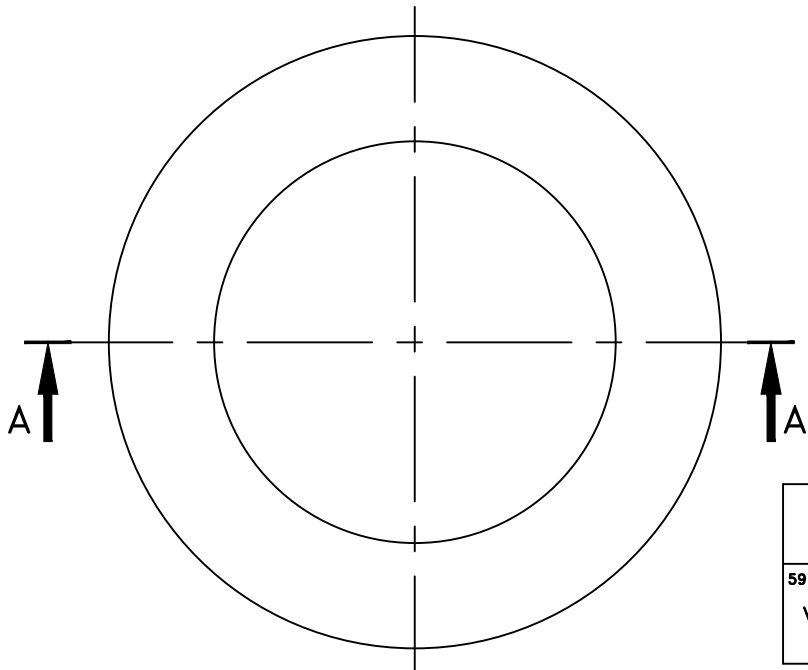

PRE-MACHINING DETAILS

TECHNICAL REQUIREMENTS

1. DRG. SHOWS THE CASTING IN ROUGH M/CED CONDITION.
2. SURFACE FINISH OF THE ROUGH M/CED CASTING TO BE 12.5 MICRONS.
3. FOLLOWING NDT TO BE DONE ON ROUGH M/CED CASTING
100% UT AS PER LEVEL-III OF AA 0850104
100% MPI AS PER LEVEL-III OF AA 0850134
4. PATTERN NO.1239826.
5. CASTING WEIGHT=114 KG.

59		64	65	75	78	79	25	27	29	58	59	60	77	29	31	34	45	55	56	57	58	65	72	
VAR.OO		REMARKS			VAR NO.	ITEM NO.		DESCRIPTION						STD.	DRAWING NO.		MATL. CODE		UNIT		UNIT WT.		QTY.	
					001	BOSS CASTING											AA19521		114.00		001			
																			A		C			

28 → CARD TYPE-3

28 → CARD TYPE-1

28 → CARD TYPE-2

DRAWING REVIEW				ADDITIONAL INFORMATION				TYPE OF PRODUCT OR NAME OF CUSTOMER/PROJECT										
DEPT.	NAME	SIGN.	DATE	STATUS OF DRAWING U				PRANAHITA-VI LIS (6x124.4 MW)										
DISTRIBUTION OF PRINTS				Bharat Heavy Electricals Ltd. Bhopal				DRN										
HTE-2, FYM-4, THX-1				WTM(PLANNING)-1, WTM(STORE)-4				CKD										
								APPD										
								NAME										
								SIGN										
								DATE										
								NO. OF VAR.										
REV.	DATE	ALTERED	APPD.	REV.	DATE	ALTERED	APPD.	REV.	DATE	ALTERED	APPD.	DEPT. H.T.E.	UNTOL. DIMS. GR.	SCALE	WEIGHT(K.G.)	REF.TO ASSY.DRG.	ITEM NO.	NO.OF ITEM
		CHECKED				CHECKED		01	9.2.16	CHECKED		402	32000049014	1:5	100.00	02030118402	006	001
				DRAWING REVISED ON ADVISE OF WTM-PLANNING PRE-M/Cg DETAIL ADDED.				TITLE										
								BOSS										
								DRAWING NO.										
								3-203-01-18416										
								REV.										
								01										
								SHT. NO. 1		NO. OF SHT. 1								

THE INFORMATION ON THIS DOCUMENT IS THE PROPERTY OF BHARAT HEAVY ELECTRICALS LIMITED. IT MUST NOT BE USED DIRECTLY OR INDIRECTLY IN ANY WAY DETRIMENTAL TO THE INTEREST OF THE COMPANY.

32030116818

REF. DRG. NO.

SIGN. & DATE

INVENTORY NO.

A3 SIZE

FIRST ANGLE PROJECTION

(ALL DIMENSIONS ARE IN mm)

THE INFORMATION ON THIS DOCUMENT IS THE PROPERTY OF BHARAT HEAVY ELECTRICALS LIMITED. IT MUST NOT BE USED DIRECTLY OR INDIRECTLY IN ANY WAY DETRIMENTAL TO THE INTEREST OF THE COMPANY.

REV.	DATE	ALTERED CHECKED APPD.	REV.	DATE	ALTERED CHECKED APPD.	ADDITIONAL INFORMATION
						STATUS OF DRAWING 'U'
						DISTRIBUTION OF PRINTS HTE-2 THX-1 WTM(PLANING)-1 WTM(STORE)-4

3.2/ ALL OVER UNLESS OTHERWISE STATED

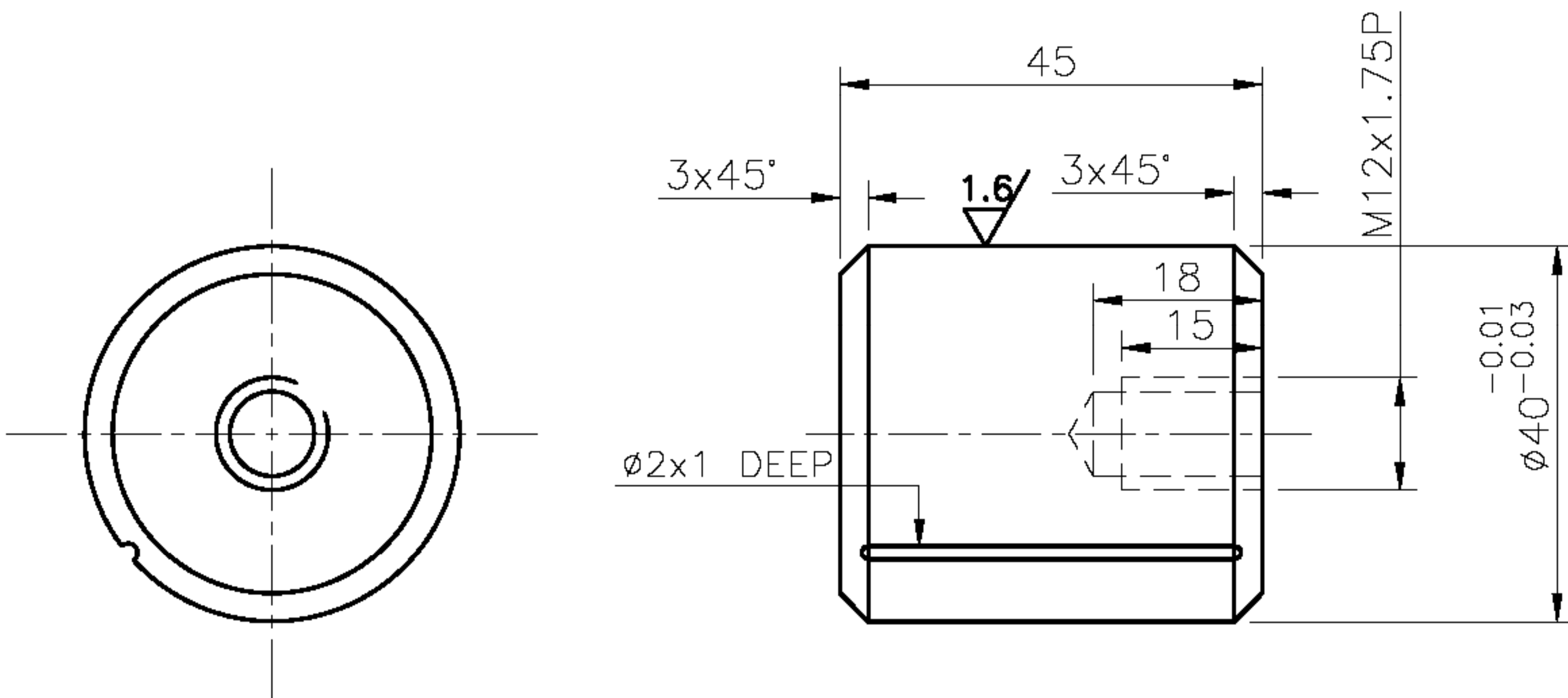

TECHNICAL REQUIREMENTS

1. REMOVE ALL BURRS AND SHARP EDGES.

4-202-01-184-08
REF. DRG. NO.

SIGN. & DATE

INVENTORY NO.

REMARKS	ITEM NO.	DESCRIPTION	STD	46	MATL. SPCN.	54	A C	UNIT	57	58	UNIT WT.	65	66	QTY.	71
ø56 BAR	001	DOWEL			AA 1070223190						0.350				
					AA 10723								001		

PRANAHITA-VI LIS (6x124.4 MW)	BHARAT HEAVY ELECTRICALS LTD. BHOPAL		DRN	NEERAJ	SIGN	30.10.15	NO. OF VAR.
	DEPT. H.T.E.	UNTOL. DIMS. GR.	CKD	ND	SIGN	30.10.15	
	CODE 402	32000049014	APPD	SK	SIGN	30.10.15	
TITLE		SCALE	WEIGHT(K.G.)	REF.TO ASSY.DRG.	ITEM NO.	NO.OF ITEM	
DOWEL		1 : 1	0.350	0-203-01-184-01	047	001	
				DRAWING NO.	REV.		
				4-203-01-184-02	00		
			SHT. NO. 01	NO. OF SHT. 01			

SIZE A4



COMBINED BILL OF MATERIAL

Printed On:06.04.2022

Printed By:

CBOM No: 02030121502 CBOM Var: 00 Revno: 2 Rev Date: 30.07.2021
Description: OUTER TOP COVER(INQUADRANTS) Total weight: 38800.0

RECORD OF CHANGES

Drawing No	Var	Revno	Rev Date	Description
02030121502	00	1	26.07.2021	Blank weight update in item 1,2 & 10
02030121502	00	2	29.07.2021	Blank size optimized and norm per piece updated in item no-1 & 2

CBOM - 02030121502 00

	ENGG		MTE		TTX		WTX	
	Initial	Date	Initial	Date	Initial	Date	Initial	Date
Worked By	stemoh	18.06.2021	mtesub	07.07.2021	ttxsk	08.07.2021	bk2rd	03.07.2021
Checked By	stemun	07.07.2021	mtesub	07.07.2021	ttxsk	08.07.2021	bk2rd	03.07.2021
Approved By	stevsh	12.07.2021	mteasr	07.07.2021	tbrmrk	08.07.2021	wtxblm	03.07.2021



COMBINED BILL OF MATERIAL

Printed On:06.04.2022

Printed By:

CBOM No: 02030121502 **CBOM Var:** 00 **Revno:** 2
Description: OUTER TOP COVER(INQUADRANTS)

Rev Date: 30.07.2021
Total weight: 38800.0

Item No	Drawingno Var Mvar	Mat Code	Mat Spec	Weight	Blank Sizes	Nos	Qty	Norm/pc	Extra Norm	Total Norm
Qty(Total)	Description		Assy. Remarks	Inclusion?	Mat Shape		Remarks			
Typ Cat Zone	Var/Matl. Description		ENGG SIZE/GRP	Fab Wt	Route				Spare Code	Unit
0	02030121502 00			38800.0						
1(1)	OUTER TOP COVER(INQUADRANTS)			Y						
MF			N		0306-0313-0236-0306-0236					
1		W96321301027		5170.0	3175.0X2190.0	1	4	8605.0	0.0	34420.0
4(4)			refer drg 02030121502	Y	150 TK X 2500 X 5500					
MF DR	PLATE IS2062 E300 (BR) - 150TK				0072-0301-0306					KG
2		W96320301015		3725.0	2640.0X2050.0	1	4	6251.0	0.0	25004.0
4(4)			Refer Drg. 02030121502	Y	140 TK X 2500 X 6000					
MF DR	PLATE IS2062 E300 (BR) - 140TK				0072-0301-0306					KG
3		AA1011819260	AA10119	248.0	634.0X625.0	1	8	261.5	0.0	2092.0
8(8)			refer drg 02030121502	Y	PL 80					
RM DR	ST-FE410 WB-PLATE				0072-0301-0306					KG
4		AA1011819198	AA10119	124.0	634.0X625.0	1	16	131.0	0.0	2096.0
16(16)			refer drg 02030121502	Y	PL 40					
RM DR	ST-FE410 WB-PLATE				0072-0301-0306					KG
5		AA1011819228	AA10119	1435.0	5561.0X634.0	1	4	1629.0	0.0	6516.0
4(4)			refer drg 02030121502	Y	PL 56					
MF DR	ST-FE410 WB-PLATE				0072-0301-0306					KG
6	32030118416 00	W92320301011	AA19521	100.0	460.0X460.0	1	20	1.0	0.0	20.0
20(20)	BOSS			Y						
CE CD					0073-0317-0306					NO
7		AA1011819155	AA10119	5.3	534.0X50.0	1	8	5.5	0.0	44.0
8(8)				Y	PL 25					
RM DR	ST-FE410 WB-PLATE				0072-0301-0306					KG
8		AA1011819155	AA10119	2.5	250.0X50.0	1	16	2.6	0.0	41.6
16(16)				Y	PL 25					
RM DR	ST-FE410 WB-PLATE				0072-0301-0306					KG
9	42030118402 00	AA1070223190	AA10723	0.35	55.0	1	12	1.1	0.0	13.2
12(12)	DOWEL			Y	RND 56		L=55			
MF DR					0072-0236					KG

	ENGG		MTE		TTX		WTX	
	Initial	Date	Initial	Date	Initial	Date	Initial	Date
Worked By	stemoh	18.06.2021	mtesub	07.07.2021	ttxsk	08.07.2021	bk2rd	03.07.2021
Checked By	stemun	07.07.2021	mtesub	07.07.2021	ttxsk	08.07.2021	bk2rd	03.07.2021
Approved By	stevsh	12.07.2021	mteasr	07.07.2021	tbrmrkr	08.07.2021	wtxblm	03.07.2021



COMBINED BILL OF MATERIAL

Printed On:06.04.2022

Printed By:

CBOM No: 02030121502 **CBOM Var:** 00 **Revno:** 2 **Rev Date:** 30.07.2021
Description: OUTER TOP COVER(INQUADRANTS) **Total weight:** 38800.0

Item No	Drawingno	Var	Mvar	Mat Code	Mat Spec	Weight	Blank Sizes	Nos	Qty	Norm/pc	Extra Norm	Total Norm
Qty(Total)	Description			Assy. Remarks	Inclusion?	Mat Shape	Remarks					
Typ	Cat	Zone	Var/Matl. Description	ENGG SIZE/GRP	Fab Wt	Route	Spare Code	Unit				
10				W96321501166		6.5	665.0X85.0	1	24	6.8	0.0	163.2
24(24)					refer drg.02030121502	Y	12TK X 1200 WIDTH X 4200 LONG					
MF	DR		S. S PLATES (13% CR - 4% NI)				0072-0301-0306					KG
11				AA1011819210	AA10119	4.0	100.0X100.0	1	2	4.2	0.0	8.4
2(2)			100*100;T=50MM			Y	PL 50					
RM	DR		ST-FE410 WB-PLATE				0072-0301-0306					KG
12				AA1010112198	AA10112	0.25	40.0	1	2	0.35	0.0	0.7
2(2)			DIA.40MM		refer drg.02030121502	Y	HEX 46					
MF	DR		ST-CD-HEX				0072-0301-0317-0306					KG

CBOM - 02030121502

	ENGG		MTE		TTX		WTX	
	Initial	Date	Initial	Date	Initial	Date	Initial	Date
Worked By	stemoh	18.06.2021	mtesub	07.07.2021	ttxsk	08.07.2021	bk2rd	03.07.2021
Checked By	stemun	07.07.2021	mtesub	07.07.2021	ttxsk	08.07.2021	bk2rd	03.07.2021
Approved By	stevsh	12.07.2021	mteasr	07.07.2021	tbrmrk	08.07.2021	wtxblm	03.07.2021



COMBINED BILL OF MATERIAL

Printed On:06.04.2022

Printed By:

CBOM No: 02030121503 CBOM Var: 00

Revno: 2

Rev Date: 15.03.2022

Description: INNER TOP COVER

Total weight: 38100.0

RECORD OF CHANGES

Drawing No	Var	Revno	Rev Date	Description
02030121503	00	1	26.07.2021	Blank weight update in item 1,6,7,18,23 & 25 Change in Raw material of Item no. 4
02030121503	00	2	03.03.2022	Replacement of Material Code W96321501131 with W96321501085.

CBOM - 02030121503 00

	ENGG		TTX		WTX	
	Initial	Date	Initial	Date	Initial	Date
Worked By	stemoh	18.06.2021	txsk	08.07.2021	bk2rd	03.07.2021
Checked By	stemun	07.07.2021	txsk	08.07.2021	bk2rd	03.07.2021
Approved By	stevsh	12.07.2021	tbrkr	08.07.2021	wtxblm	03.07.2021



COMBINED BILL OF MATERIAL

Printed On:06.04.2022

Printed By:

CBOM No: 02030121503 CBOM Var: 00

Revno: 2

Rev Date: 15.03.2022

Description: INNER TOP COVER

Total weight: 38100.0

Item No	Drawingno Var Mvar	Mat Code	Mat Spec	Weight	Blank Sizes	Nos	Qty	Norm/pc	Extra Norm	Total Norm
Qty(Total)	Description		Assy. Remarks	Inclusion?	Mat Shape		Remarks			
Typ Cat Zone	Var/Matl. Description		ENGG SIZE/GRP	Fab Wt	Route				Spare Code	Unit
0	02030121503 00			38100.0						
1(1)	INNER TOP COVER			Y						
MF			N		0306-0313-0236-0306-0236					
1		W96321501018		1180.0	1220.0X1320.0	1	1	1727.0	0.0	1727.0
1(1)			Refer drg. 02030121503	Y	130 TK X 2000 X 6000			Make in 6 parts.		
MF DR	PLATE IS2062 E300 (BR) - 130TK				0072-0301-0306					KG
2		AA1011819228	AA10119	52.5	600.0X200.0	1	8	55.5	0.0	444.0
8(8)			Refer Drg.02030121503	Y	PL 56					
MF DR	ST-FE410 WB-PLATE				0072-0301-0306					KG
3		AA1011819244	AA10119	4510.0	2460.0X4510.0	1	1	6407.0	0.0	6407.0
1(1)			Refer Drg. 02030121503	Y	PL 70			Make in 6 parts.		
MF DR	ST-FE410 WB-PLATE				0072-0301-0306					KG
4		W96321501018		5555.0	3130.0X2128.0	1	1	7144.0	0.0	7144.0
1(1)			Refer Drg.02030121503	Y	130 TK X 2000 X 6000			Make in 8 parts.		
MF DR	PLATE IS2062 E300 (BR) - 130TK				0072-0301-0306					KG
5		AA1011819244	AA10119	4226.0	662.0X13218.0	1	1	5053.0	0.0	5053.0
1(1)			Refer Drg.02030121503	Y	PL 70			make in 4 parts. BA. included		
MF DR	ST-FE410 WB-PLATE				0072-0301-0306					KG
6		W96321501085		165.0	55.0X12745.0	1	1	185.0	0.0	185.0
1(1)			Ref Drg. 02030121503	Y	32TK X 1250 WIDTH X 5000 LG			make in 8 parts. BA included		
MF DR	S. S PLATES (13% CR - 4% NI)				0072-0301-0306					KG
7		W96321501085		255.0	1990.0X905.0	1	1	475.0	0.0	475.0
1(1)			Ref Drg. 02030121503	Y	32TK X 1250 WIDTH X 5000 LG			Make in 6 parts.		
MF DR	S. S PLATES (13% CR - 4% NI)				0072-0301-0306					KG
8		AA1011819155	AA10119	2.7	177.0X78.0	1	20	2.85	0.0	57.0
20(20)			Refer Drg no. 02030121503	Y	PL 25					
MF DR	ST-FE410 WB-PLATE				0072-0301-0306					KG
9		AA1011819210	AA10119	4695.0	17551.0X751.0	1	1	5437.0	0.0	5437.0
1(1)			Ref Drg. 02030121503	Y	PL 50			Make in 4 parts.		
MF DR	ST-FE410 WB-PLATE				0072-0301-0306					KG

ENGG

TTX

WTX

Initial

Date

Initial

Date

Initial

Date

Worked By

stemoh

18.06.2021

ttxsk

08.07.2021

bk2rd

03.07.2021

Checked By

stemun

07.07.2021

ttxsk

08.07.2021

bk2rd

03.07.2021

Approved By

stevsh

12.07.2021

tbrmrkr

08.07.2021

wtxblm

03.07.2021



COMBINED BILL OF MATERIAL

Printed On:06.04.2022

Printed By:

CBOM No: 02030121503 **CBOM Var:** 00
Description: INNER TOP COVER

Revno: 2

Rev Date: 15.03.2022

Total weight: 38100.0

Item No	Drawingno Var Mvar	Mat Code	Mat Spec	Weight	Blank Sizes	Nos	Qty	Norm/pc	Extra Norm	Total Norm
Qty(Total)	Description		Assy. Remarks	Inclusion?	Mat Shape		Remarks			
Typ Cat Zone	Var/Matl. Description		ENGG SIZE/GRP	Fab Wt	Route				Spare Code	Unit
10		AA1011819171	AA10119	220.0	1535.0X908.0	1	8	368.0	0.0	2944.0
8(8)			Refer Drg. 02030121503	Y	PL 32					
MF DR	ST-FE410 WB-PLATE				0072-0301-0306					KG
11		AA1011819244	AA10119	1121.0	2630.0X1280.0	1	1	1944.0	0.0	1944.0
1(1)			REFER DRG NO. 02030121503	Y	PL 70					Make in 6 parts.
MF DR	ST-FE410 WB-PLATE				0072-0301-0306					KG
12		AA1011819244	AA10119	5469.0	4082.0X3575.0	1	1	8427.0	0.0	8427.0
1(1)			Refer Drg. 02030121503	Y	PL 70					Make in 4 parts.
MF DR	ST-FE410 WB-PLATE				0072-0301-0306					KG
13		AA1011819201	AA10119	15.0	318.0X318.0	1	10	37.6	0.0	376.0
10(10)			Refer Drg. 02030121503	Y	PL 45					
MF DR	ST-FE410 WB-PLATE				0072-0301-0317-0306					KG
14		AA1011819244	AA10119	3139.0	3370.0X2545.0	1	1	4953.0	0.0	4953.0
1(1)			Ref Drg. 02030121503	Y	PL 70					Make in 4 parts.
MF DR	ST-FE410 WB-PLATE				0072-0301-0306					KG
15		AA1011819244	AA10119	1278.0	1764.0X1030.0	1	1	1342.0	0.0	1342.0
1(1)			REFER DRG. 02030121503	Y	PL 70					Make in 6 parts.
MF DR	ST-FE410 WB-PLATE				0072-0301-0306					KG
16		AA1011819198	AA10119	95.0	1707.0X200.0	1	2	113.0	0.0	226.0
2(2)			Refer Drg. 02030121503	Y	PL 40					
MF DR	ST-FE410 WB-PLATE				0072-0301-0306					KG
17		AA1011819260	AA10119	812.0	1935.0X1070.0	1	1	1366.0	0.0	1366.0
1(1)			Refer Drg. 02030121503	Y	PL 80					Make in 6 parts.
MF DR	ST-FE410 WB-PLATE				0072-0301-0306					KG
18		W96321501166		5.0	1568.0X70.0	1	6	10.9	0.0	65.4
6(6)			Ref Drg. 02030121503	Y	12TK X 1200 WIDTH X 4200 LONG					
MF DR	S. S PLATES (13% CR - 4% NI)				0072-0301-0306					KG
19		AA1011819155	AA10119	24.5	627.0X200.0	1	8	26.0	0.0	208.0
8(8)			Refer Drg. 02030121503	Y	PL 25					
MF DR	ST-FE410 WB-PLATE				0072-0301-0306					KG

ENGG

TTX

WTX

	Initial	Date	Initial	Date	Initial	Date
Worked By	stemoh	18.06.2021	ttxsk	08.07.2021	bk2rd	03.07.2021
Checked By	stemun	07.07.2021	ttxsk	08.07.2021	bk2rd	03.07.2021
Approved By	stevsh	12.07.2021	tbtmrkr	08.07.2021	wtxblm	03.07.2021



COMBINED BILL OF MATERIAL

Printed On:06.04.2022

Printed By:

CBOM No: **02030121503** CBOM Var: **00**

Revno: **2**

Rev Date: **15.03.2022**

Description: **INNER TOP COVER**

Total weight: **38100.0**

Item No	Drawingno	Var	Mvar	Mat Code	Mat Spec	Weight	Blank Sizes	Nos	Qty	Norm/pc	Extra Norm	Total Norm
Qty(Total)	Description				Assy. Remarks	Inclusion?	Mat Shape			Remarks		
Typ	Cat	Zone	Var/Matl.	Description	ENGG SIZE/GRP	Fab Wt	Route				Spare Code	Unit
20				AA1011819171	AA10119	85.0	680.0X500.0	1	16	90.0	0.0	1440.0
16(16)					Refer Drg. 02030121503	Y	PL 32					
MF	DR			ST-FE410 WB-PLATE			0072-0301-0306					KG
21				AA1011819236	AA10119	1030.0	13807.0X165.0	1	1	1184.0	0.0	1184.0
1(1)					Refer Drg. 02030121503	Y	PL 63			Make in 6 parts.		
MF	DR			ST-FE410 WB-PLATE			0072-0301-0306					KG
22				AA1011819236	AA10119	343.0	12777.0X60.0	1	1	398.0	0.0	398.0
1(1)					Refer Drg. 02030121503	Y	PL 63			Make in 6 parts.		
MF	DR			ST-FE410 WB-PLATE			0072-0301-0306					KG
23				W96321501166		5.0	1327.0X80.0	1	18	10.5	0.0	189.0
18(18)					Ref Drg. 02030121503	Y	12TK X 1200 WIDTH X 4200 LONG					
MF	DR			S. S PLATES (13% CR - 4% NI)			0072-0301-0306					KG
24				AA1011819155	AA10119	1.5	152.0X152.0	1	4	4.7	0.0	18.8
4(4)					Refer Drg. 02030121503	Y	PL 25					
MF	DR			ST-FE410 WB-PLATE			0072-0301-0317-0306					KG
25				W96321501166		24.0	1971.0X271.0	1	8	52.8	0.0	422.4
8(8)					Ref Drg. 02030121503	Y	12TK X 1200 WIDTH X 4200 LONG					
MF	DR			S. S PLATES (13% CR - 4% NI)			0072-0301-0306					KG
26				AA1041055749	AA10455	56.5	2000.0	1	1	2.0	0.0	2.0
1(1)					LENGTH=2000MM	Y	PI 168.3X7.10			L=2000		
RM	DR			ST-B-HFS-PIPES			0072-0301-0306					MR
27				AA1010209183	AA10109	0.15	50.0X50.0	1	50	0.21	0.0	10.5
50(50)					THICKNESS=10MM	Y	RND 50					
RM	DR			ST-C20-HR-RND			0072-0301-0306					KG

ENGG

TTX

WTX

Initial

Date

Initial

Date

Initial

Date

Worked By

stemoh

18.06.2021

ttxsk

08.07.2021

bk2rd

03.07.2021

Checked By

stemun

07.07.2021

ttxsk

08.07.2021

bk2rd

03.07.2021

Approved By

stevsh

12.07.2021

tbrmrkr

08.07.2021

wtxblm

03.07.2021

Certificate

In line with Government Public Procurement Order No. P-45021/2/2017-BE-II dt. 15.06.2017 & P-45021/2/2017-PP (BE-II) dated 28.05.2018, we hereby certify that we M/s Â _____(supplier name) are local supplier meeting the requirement of minimum local content (50%) as defined in above orders for the material against Enquiry No.

Details of location at which local value addition will be made is as follows:

We also understand, false declarations will be in breach of the Code of Integrity under Rule 175(1)(i)(h) of the General Financial Rules for which a bidder or its successors can be debarred for up to two years as per Rule 151 (iii) of the General Financial Rules along with such other actions as may be permissible under law.

Seal and Signature of Supplier

INTEGRITY PACT

Between

Bharat Heavy Electricals Ltd. (BHEL), a company registered under the Companies Act 1956 and having its registered office at "BHEL House", Siri Fort, New Delhi – 110049 (India) hereinafter referred to as "The Principal", which expression unless repugnant to the context or meaning hereof shall include its successors or assigns of the ONE PART

and

_____, (description of the party along with address), hereinafter referred to as "The Bidder/ Contractor" which expression unless repugnant to the context or meaning hereof shall include its successors or assigns of the OTHER PART

Preamble

The Principal intends to award, under laid-down organizational procedures, contract/s for

_____. The Principal values full compliance with all relevant laws of the land, rules and regulations, and the principles of economic use of resources, and of fairness and transparency in its relations with its Bidder(s)/ Contractor(s).

In order to achieve these goals, the Principal will appoint Independent External Monitor(s), who will monitor the tender process and the execution of the contract for compliance with the principles mentioned above.

Section 1 – Commitments of the Principal

- 1.1 The Principal commits itself to take all measures necessary to prevent corruption and to observe the following principles:-
 - 1.1.1 No employee of the Principal, personally or through family members, will in connection with the tender for, or the execution of a contract, demand, take a promise for or accept, for self or third person, any material or immaterial benefit which the person is not legally entitled to.
 - 1.1.2 The Principal will, during the tender process treat all Bidder(s) with equity and reason. The Principal will in particular, before and during the tender process, provide to all Bidder(s) the same information and will not provide to any Bidder(s) confidential / additional information through which the Bidder(s) could obtain an advantage in relation to the tender process or the contract execution.
 - 1.1.3 The Principal will exclude from the process all known prejudiced persons.
- 1.2 If the Principal obtains information on the conduct of any of its employees which is a penal offence under the Indian Penal Code 1860 and Prevention of Corruption Act 1988 or any other statutory penal enactment, or if there be a substantive suspicion in this regard, the Principal will inform its Vigilance Office and in addition can initiate disciplinary actions.

Section 2 – Commitments of the Bidder(s)/ Contractor(s)

- 2.1 The Bidder(s)/ Contractor(s) commit himself to take all measures necessary to prevent corruption. He commits himself to observe the following principles during his participation in the tender process and during the contract execution.
 - 2.1.1 The Bidder(s)/ Contractor(s) will not, directly or through any other person or firm, offer, promise or give to the Principal or to any of the Principal's employees involved

in the tender process or the execution of the contract or to any third person any material, immaterial or any other benefit which he / she is not legally entitled to, in order to obtain in exchange any advantage of any kind whatsoever during the tender process or during the execution of the contract.

- 2.1.2 The Bidder(s)/ Contractor(s) will not enter with other Bidder(s) into any illegal or undisclosed agreement or understanding, whether formal or informal. This applies in particular to prices, specifications, certifications, subsidiary contracts, submission or non-submission of bids or any other actions to restrict competitiveness or to introduce cartelization in the bidding process.
- 2.1.3 The Bidder(s)/ Contractor(s) will not commit any penal offence under the relevant IPC/ PC Act; further the Bidder(s)/ Contractor(s) will not use improperly, for purposes of competition or personal gain, or pass on to others, any information or document provided by the Principal as part of the business relationship, regarding plans, technical proposals and business details, including information contained or transmitted electronically.
- 2.1.4 The Bidder(s)/ Contractor(s) will, when presenting his bid, disclose any and all payments he has made, and is committed to or intends to make to agents, brokers or any other intermediaries in connection with the award of the contract.
- 2.2 The Bidder(s)/ Contractor(s) will not instigate third persons to commit offences outlined above or be an accessory to such offences.

Section 3 – Disqualification from tender process and exclusion from future contracts

If the Bidder(s)/ Contractor(s), before award or during execution has committed a transgression through a violation of Section 2 above, or acts in any other manner such as to put his reliability or credibility in question, the Principal is entitled to disqualify the Bidder(s)/ Contractor(s) from the tender process or take action as per the separate "Guidelines on Banning of Business dealings with Suppliers/ Contractors". framed by the Principal.

Section 4 – Compensation for Damages

- 4.1 If the Principal has disqualified the Bidder from the tender process prior to the award according to Section 3, the Principal is entitled to demand and recover the damages equivalent Earnest Money Deposit/Bid Security.
- 4.2 If the Principal has terminated the contract according to Section 3, or if the Principal is entitled to terminate the contract according to section 3, the Principal shall be entitled to demand and recover from the Contractor liquidated damages equivalent to 5% of the contract value or the amount equivalent to Security Deposit/Performance Bank Guarantee, whichever is higher.

Section 5 – Previous Transgression

- 5.1 The Bidder declares that no previous transgressions occurred in the last 3 years with any other company in any country conforming to the anti-corruption approach or with any other Public Sector Enterprise in India that could justify his exclusion from the tender process.
- 5.2 If the Bidder makes incorrect statement on this subject, he can be disqualified from the tender process or the contract, if already awarded, can be terminated for such reason.

Section 6 – Equal treatment of all Bidders/ Contractors/ Sub-contractors

- 6.1 The Bidder(s)/ Contractor(s) undertake(s) to obtain from all subcontractors a commitment consistent with this Integrity Pact and report Compliance to the Principal. This commitment shall be taken only from those sub-contractors whose contract value is more than 20 % of Bidder's/ Contractor's contract value with the Principal. The Bidder(s)/ Contractor(s) shall continue to remain responsible for any default by his Sub-contractor(s).
- 6.2 The Principal will enter into agreements with identical conditions as this one with all Bidders and Contractors.
- 6.3 The Principal will disqualify from the tender process all bidders who do not sign this pact or violate its provisions.

Section 7 – Criminal Charges against violating Bidders/ Contractors /Sub-contractors

If the Principal obtains knowledge of conduct of a Bidder, Contractor or Subcontractor, or of an employee or a representative or an associate of a Bidder, Contractor or Subcontractor which constitutes corruption, or if the Principal has substantive suspicion in this regard, the Principal will inform the Vigilance Office.

Section 8 –Independent External Monitor(s)

- 8.1 The Principal appoints competent and credible Independent External Monitor for this Pact. The task of the Monitor is to review independently and objectively, whether and to what extent the parties comply with the obligations under this agreement.

- 8.2 The Monitor is not subject to instructions by the representatives of the parties and performs his functions neutrally and independently. He reports to the CMD, BHEL.
- 8.3 The Bidder(s)/ Contractor(s) accepts that the Monitor has the right to access without restriction to all contract documentation of the Principal including that provided by the Bidder(s)/ Contractor(s). The Bidder(s)/ Contractor(s) will grant the monitor, upon his request and demonstration of a valid interest, unrestricted and unconditional access to his contract documentation. The same is applicable to Sub-contractor(s). The Monitor is under contractual obligation to treat the information and documents of the Bidder(s)/ Contractor(s) / Sub-contractor(s) with confidentiality.
- 8.4 The Principal will provide to the Monitor sufficient information about all meetings among the parties related to the contract provided such meetings could have an impact on the contractual relations between the Principal and the Contractor. The parties offer to the Monitor the option to participate in such meetings.
- 8.5 As soon as the Monitor notices, or believes to notice, a violation of this agreement, he will so inform the Management of the Principal and request the Management to discontinue or take corrective action, or heal the situation, or to take other relevant action. The Monitor can in this regard submit non-binding recommendations. Beyond this, the Monitor has no right to demand from the parties that they act in a specific manner, refrain from action or tolerate action.
- 8.6 The Monitor will submit a written report to the CMD, BHEL within 8 to 10 weeks from the date of reference or intimation to him by the Principal and, should the occasion arise, submit proposals for correcting problematic situations.
- 8.7 The CMD, BHEL shall decide the compensation to be paid to the Monitor and its terms and conditions.
- 8.8 If the Monitor has reported to the CMD, BHEL, a substantiated suspicion of an offence under relevant IPC / PC Act, and the CMD, BHEL has not, within reasonable time, taken visible action to proceed against such offence or reported it to the Vigilance Office, the

Monitor may also transmit this information directly to the Central Vigilance Commissioner, Government of India.

8.9 The number of Independent External Monitor(s) shall be decided by the CMD, BHEL.

8.10 The word 'Monitor' would include both singular and plural.

Section 9 – Pact Duration

9.1 This Pact begins and shall be binding on and from the submission of bid(s) by bidder(s). It expires for the Contractor 12 months after the last payment under the respective contract and for all other Bidders 6 months after the contract has been awarded.

9.2 If any claim is made / lodged during this time, the same shall be binding and continue to be valid despite the lapse of this pact as specified as above, unless it is discharged/ determined by the CMD, BHEL.

Section 10 – Other Provisions

10.1 This agreement is subject to Indian Laws and jurisdiction shall be registered office of the Principal, i.e. New Delhi.

10.2 Changes and supplements as well as termination notices need to be made in writing. Side agreements have not been made.

10.3 If the Contractor is a partnership or a consortium, this agreement must be signed by all partners or consortium members.

10.4 Should one or several provisions of this agreement turn out to be invalid, the remainder of this agreement remains valid. In this case, the parties will strive to come to an agreement to their original intentions.

10.5 Only those bidders/ contractors who have entered into this agreement with the Principal would be competent to participate in the bidding. In other words, entering into this agreement would be a preliminary qualification.

For & On behalf of the Principal

For & On behalf of the Bidder/ Contractor

(Office Seal)

(Office Seal)

Place-----

Date-----

Witness: _____

Witness: _____

(Name & Address) _____

(Name & Address) _____



BHARAT HEAVY ELECTRICALS LIMITED

HEEP-HARIDWAR, UTTARAKHAND (249403)

General Instructions and Standard Terms & Conditions for bidding against Tender Enquiry (GISTC)

For Indian Bidders (Version June-2021, Rev: 06)

Table of Contents

1. GENERAL	1
2. ORIGIN OF QUOTATION	1
3. SUBMISSION OF TENDER	1
4. TENDER OPENING	2
5. SPECIFICATION, DRAWINGS & STANDARD	2
6. PRICE SCHEDULE	3
7. REVERSE AUCTION	3
8. DELIVERY TERMS	3
9. LD FOR LATE DELIVERY	4
10. PAYMENT TERMS	4
11. TAXES & DUTIES	5
12. BANK GUARANTEE	6
13. GUARANTEE / WARRANTY AND CORRESPONDING REPAIRS / REPLACEMENT OF GOODS	6
14. QUALITY REQUIREMENT	6
15. VALIDITY	6
16. RIGHT OF ACCEPTANCE	6
17. TRANSIT INSURANCE	7
18. RISK PURCHASE	7
19. FORCE MAJEURE CLAUSE	7
20. NON-DISCLOSURE AGREEMENT	8
21. SETTLEMENT OF DISPUTES / ARBITRATION	8
22. WHARFAGE / DEMURRAGE RESPONSIBILITY	8
23. CONDITIONS FOR AVAILING MICRO & SMALL ENTERPRISES (MSE'S) BENEFITS	8
24. INFORMATION TO THE BIDDERS	10
25. MAKE IN INDIA (GOVT-NOTIFICATION)	10
26. RESTRICTIONS UNDER RULE 144(XI) OF THE GENERAL FINANCIAL RULES (GFRs), 2017	12

27. NOTE..... 12

1. GENERAL.

These general terms & conditions shall apply to all the Tender Enquiries, notice inviting tenders, request for quotations concerning the supply of goods and / or rendering of services to Bharat Heavy Electricals Ltd., HEEP, Haridwar (hereinafter referred to as BHEL or the Purchaser). In case of placement of order these conditions will become part of Purchase Order (P.O) until unless the deviations are specifically agreed by BHEL.

2. ORIGIN OF QUOTATION.

- a) The quotation should preferably be from the principal bidder. However tender specific authorized registered dealer/agent can also submit the bid on their behalf, failing which the quotation is liable to be ignored. BHEL prefers to deal directly with the principal manufacturers.
- b) An agent cannot quote on behalf of more than one principal in the same Tender Enquiry.

3. SUBMISSION OF TENDER.

- a) Bid / Quotation must be enclosed in sealed cover on which tender enquiry number and the due date MUST BE written and be invariably sent under REGISTERED POST / SPEED POST / COURIER / Dropped in the Tender Box: addressed as follows:

Quotation against Enquiry No. _____

Dated: _____

Due on: _____

To,

**THE HEAD OF MATERIALS MANAGEMENT,
Heavy Electrical Equipment Plant,
Bharat Heavy Electricals Limited,
HARIDWAR-249403 (Uttarakhand), INDIA.**

- b) TENDER ROOM is located at: Room No. - 415, 4th Floor, Main Admin. Building, BHEL-HEEP, Haridwar.

Quotations / Bids not in accordance with General Instructions and Standard Terms & Conditions are likely to be ignored.



BHARAT HEAVY ELECTRICALS LIMITED

HEEP-HARIDWAR, UTTARAKHAND (249403)

General Instructions and Standard Terms & Conditions for bidding against Tender Enquiry (GISTC)

For Indian Bidders (Version June-2021, Rev: 06)

- c) In case of Three / Two Part Bid, technical bid containing technical offer, duly signed and un-priced copy of the Price Bid should be kept in one envelope. Price Bid containing only the price should be kept in a separate envelope. All envelopes indicating Part-1 or Part-2 or Part-3 as the case may be to be put in a bigger envelope. Please note that un-priced bid should be the exact replica of price bid but without prices.
- d) The bid / quotation must be posted before due date, keeping allowance for postal transit time. Quotations sent by any mode but not received in time will be ignored. Tender received through authorized E-mail is also acceptable. However, in time submission of tender in tender box shall be the responsibility of the bidder, sent through any mode. Documents submitted with the offer / bid shall be signed and stamped in each page by authorized representative of the bidder.
- e) Any additional documents submitted by supplier / bidder, during processing of registration application / tender or after placement of order shall not be accepted unless it is submitted with forwarding letter and duly signed and stamped.
- f) The bids of the bidders who are on the banned list and also the bids of the bidders, who engage the services of the banned firms, shall be rejected. The cutting / overwriting in the bid / offer must be duly attested by the signatories to the bid. The list of firms banned by BHEL is available on BHEL web site www.bhel.com.
- g) Being PMD vendor, if you are not quoting against this tender enquiry, please send your regret letter positively for our reference with valid reasons for not participating in the tender enquiry. Repeated lack of response on the part of bidder may lead to deletion such PMD vendor from BHEL's approved vendor list.
- h) The bidders will submit Integrity Pact, duly signed by its authorized signatory, along with their bids wherever estimated tender value is Rs. 2 Crore or more.
- i) In case of open tender, technically qualified unregistered bidders may apply online for registration through <http://www.bhel.com/index.php/vender>.
- j) BHEL reserves the right to award tendered quantities among more than one bidder (after acceptance of L1 price by the other bidders). BHEL can also consider awarding of part of the tendered quantity to other than L-1 bidder at L1 counter offered rates, if the quantity offered by the L-1 bidder is less than the quantity tendered for.
- k) In case of e-Tendering (Online bidding through e-portal), offline bid submitted in hard copy or in any other form by the vendor / supplier will not be accepted and will be rejected out rightly. Only e-portal bid will be accepted.

4. TENDER OPENING.

Tender opening is scheduled to start in the Tender Room at 2:00 PM, on the due date. Therefore, bid / quotations must reach this office / tender Box latest by 1:45 PM on due date. Only participating bidders are allowed to attend tender opening. **TENDERS RECEIVED AFTER THE SPECIFIED TIME OF THEIR 'SUBMISSION' WILL BE TREATED AS LATE TENDERS AND SHALL NOT BE CONSIDERED UNDER ANY CIRCUMSTANCES.** The bidders or their authorized representatives may be allowed to attend tender opening if duly authorized by their principals, through a tender specific letter on that particular day. General authorization letter is not acceptable.

Note: - Foreign bidders willing to attend the bid opening has to provide the requisite documents to the concerned Purchase executives for arranging gate pass for them.

5. SPECIFICATION, DRAWINGS & STANDARD.

- a) Bidders must give their detailed specification in the quotation along with relevant technical literature / catalogue etc. against the tender enquiry.
- b) The Bid should be accompanied with relevant copies of catalogues, drawings or specification as per tender enquiry.



BHARAT HEAVY ELECTRICALS LIMITED

HEEP-HARIDWAR, UTTARAKHAND (249403)

General Instructions and Standard Terms & Conditions for bidding against Tender Enquiry (GISTC)

For Indian Bidders (Version June-2021, Rev: 06)

If these documents are not furnished, the offer is liable to be rejected.

- c) Wherever national / international (N/IN) standards are referred, the latest N/IN standards are to be followed. Mention year & date of standard revision that shall be followed for the supply.
- d) All Drawings and Standards are proprietary of BHEL. It must not be used in anyway detrimental to the interest of BHEL or without permission of BHEL.

6. PRICE SCHEDULE.

- a) Kindly quote your prices in figures and words both. In case of any discrepancy in value, the prices quoted in words shall be considered for evaluation and establishing L1 status.
- b) Prices quoted should not be more than the prices quoted to any other BHEL units / offices / divisions. Vendor to submit copy of latest Purchase Order placed by any unit of BHEL for similar items in the technical bid. In case no order has been placed on such items, specific confirmation that no order has been placed on such items should be provided.
- c) Prices should be quoted on F.O.R. Destination basis. Transit insurance shall be arranged by BHEL and not to be included in the prices. The offers quoted on other than F.O.R destination basis may result in non-consideration of such bids.
- d) In case BHEL accepts the EX-Works prices, such offers will be loaded by 1.5% of EX-Works value towards freight or with actual freight charges as per BHEL freight rate contract whichever is higher.
- e) In case of Indigenous items covered by DGS & D Rate Contract, the bidders should submit latest valid copy of the rate contract along with bid / quotation
- f) Applicable **IGST / CGST / SGST** and any other statutory levy should be indicated separately and clearly in the bid / quotation.

- g) Bidders can dispatch goods through any Indian Bank Association approved transporters having their branch at HARIDWAR / destination. If material is dispatched through other than Indian Bank Association approved transporter, material to be delivered on door delivery BHEL Stores basis.
- h) In case of dispatch of material through any other unapproved transporter, payment shall be made only after receipt of material and any additional charges payable to the transporter shall be to the bidder's account.
- i) Any demurrage / godown rent payable to the transporter / or to godown's owner due to any delay attributed by the supplier shall be recovered from supplier's account.
- j) Currency of Evaluation shall be INR.

NB: Financial evaluation of L1, L2Status will be on the basis of Landed Cost to BHEL.

7. REVERSE AUCTION.

Wherever RA is declared in the special terms and conditions of tender enquiry, following shall be applicable and Bidders to confirm the same:

"BHEL shall be resorting to Reverse Auction (RA) (Guidelines as available on www.bhel.com) for this tender. RA shall be conducted among all the techno-commercially qualified bidders.

Price bids of all techno-commercially qualified bidders shall be opened and same shall be considered as initial bids of bidders in RA. In case any bidder(s) do(es) not participate in online Reverse Auction, their sealed envelope price bid along with applicable loading, if any, shall be considered for ranking."

8. DELIVERY TERMS.

- a) Goods shall be delivered on 'FOR Destination' basis to the named destination unless otherwise called for in the tender enquiry.
- b) Loading on account of 3rd party inspection charges in case of Indian bidders shall be 0.20%.

Quotations / Bids not in accordance with General Instructions and Standard Terms & Conditions are likely to be ignored.



BHARAT HEAVY ELECTRICALS LIMITED

HEEP-HARIDWAR, UTTARAKHAND (249403)

General Instructions and Standard Terms & Conditions for bidding against Tender Enquiry (GISTC)

For Indian Bidders (Version June-2021, Rev: 06)

9. LIQUIDATED DAMAGES (LD) FOR LATE DELIVERY.

a) Where items of Purchase Order are independently usable.

Liquidated Damages (LD) for Late Deliveries shall be applicable @0.5% per week or part thereof on the value of respective delayed supplies subject to a maximum of 10% of the value of respective delayed supplies. Value of delayed supplies will mean the Gross Value payable to the vendor (Before LD) against such supplies excluding taxes and duties.

b) Where the total items are required for a main equipment and items are interdependent.

Liquidated Damages (LD) for Late Deliveries shall be applicable @0.5% per week or part thereof on total value of Purchase Order subject to maximum of 10% of the total value of Purchase Order. Purchase Order value for this purpose shall be the Total Gross Value payable to the vendor (Before LD) excluding taxes and duties.

c) Bidders are requested to quote the best delivery meeting the delivery requirements. BHEL reserves the right to reject the offers not meeting BHEL's delivery requirement.

d) Commencement of delivery period shall be reckoned from the date of PO / LOI or any other agreed milestone.

e) Bidder shall deliver the goods in the manner and schedule agreed under the terms and conditions of Purchase order.

f) **DELIVERY IN CASE OF REJECTION:** In case the material is rejected, then date of replacement will be considered as the actual date of delivery.

g) **DELIVERY AGAINST BANK DOCUMENTS:** In case payment terms quoted by bidder are documents through bank, and the delivery terms being "FOR Haridwar / FOR Transporter Go-down" then date of delivery will be date of intimation by transporter / bidder of delivery of material at Haridwar for the LD purpose.

h) Where the payments are through bank, the documents may be presented for negotiation to BHEL authorized / nominated bank.

i) Payment of Liquidated Damages (LD) shall not in any way relieve the vendor from any of its obligations & liabilities under the contract.

10. PAYMENT TERMS.

a) BHEL's standard payment term is Payment after receipt and acceptance of materials / items at HEEP, BHEL-Store or at desired destination unless otherwise specified in Special Terms attached to the tender enquiry.

b) BHEL reserves the right to accept or reject the offer of the bidder who quotes the payment term other than BHEL's standard payment term.

c) Loading on account of deviation in payment terms shall be done as per extant rules of BHEL-Haridwar.

d) 100% payment along with taxes, freight & insurance will be made after receipt and acceptance of material and within 75 days from the date of invoice subject to submission of non-discrepant documents within 15 days of supply as per terms and conditions of Purchase Order. In case any discrepancy found in the documents, BHEL will notify the same to vendor within 7 days of receipt. Vendor has to clear all the discrepancies in one go within 7 days thereafter else the payment of vendor may get delayed.

e) For MSEs (covered under MSME Act) which are registered and periodically renewed with BHEL, the payment will be made within 45 days or as prescribed in the relevant act.

f) Adherence to the above time schedule of payment is contingent upon Vendor complying with GST Rules w.r.t availment of Input Tax Credit by BHEL.

g) In case GST credit is delayed / denied to BHEL, due to non / delayed receipt of goods and / or tax invoice or expiry of the timeline prescribed in GST Law for availing such ITC, or any other reason not attributable to BHEL, GST amount shall be recoverable from Vendor along with interest levied / leviable on BHEL.

h) The taxes and duties that are reimbursed would be the ones applicable as on the contractual Purchase order delivery date or the amount actually paid whichever is less.

Quotations / Bids not in accordance with General Instructions and Standard Terms & Conditions are likely to be ignored.



BHARAT HEAVY ELECTRICALS LIMITED

HEEP-HARIDWAR, UTTARAKHAND (249403)

General Instructions and Standard Terms & Conditions for bidding against Tender Enquiry (GISTC)

For Indian Bidders (Version June-2021, Rev: 06)

i) **The loading criteria for the different payment terms shall be as under;**

Payment Terms	Days of Loading
After Receipt & Acceptance of material within 75 days of supply.	No Loading
Against Delivery at BHEL-Stores Haridwar.	45
Against documents through bank (CAD):	45
Letter of Credit (LC)	120
Usance LC	No Loading if usance period is > 120 Days.
	Loading of days' difference i.e. difference between 120 days and usance period if the usance period is < 75 days.
Advance	Delivery Period + 120 Days - Advance Payment Days.

11. TAXES & DUTIES.

- a) The bidder to specify in their offer (part 1 bid) the category of their registration under GST like Registered, Unregistered and composite dealer.
- b) The provisional GST registration number of Bharat Heavy Electrical Ltd, Heavy Electricals Equipment Plant, Ranipur, Haridwar is "05AAACB4146P1ZL" with state Code as "05" and State Name as "Uttarakhand".
- c) Please quote our provisional GST registration number in all invoices raised for supply of goods and services under GST regime and also ensure filing of timely return and payment of tax and compliance of other applicable provisions on supplier under GST regime.
- d) No GST will be reimbursed to unregistered or composite dealer. In the event, any GST is quoted by composite dealer, the same shall be added to the cost of supply in evaluating the bid.
- e) Since, input credit of GST will be available to BHEL-Haridwar only after correct filing of return and payment of applicable GST by supplier, reimbursement of GST shall be made by

BHEL-Haridwar on matching of vendor inputs at GST portal, ensuring availability of input credit to BHEL Haridwar. Payment of GST will be made to vendor after matching of input credit and vendor to ensure submission of their invoices along with consent to accept payment of tax after such matching in all cases where bills are submitted directly to BHEL-Haridwar or through bank or under LC or through any other mode.

- f) In the event of any disallowance of input credit or applicability of interest or any other financial liability arises on BHEL-Haridwar due to any default of supplier under GST, such implication shall be to supplier's account.
- g) In the event of any change in the status of the vendor after the submission of the bid but before the supply, GST applicable at the time of supply or in the bid, based on the registration status of the vendor, whichever is lower shall be payable.
- h) Where ever applicable If PAN (Permanent Account Number) of the recipient is not available, income tax is deductible either at the normal rate or at the rate of 20 percent, whichever is higher as per Section 206AA of Indian Income Tax Act 1961.
- i) The bidder shall clearly indicate HSN (*Harmonised System Nomenclature*) / SAC (*Service Accounting Code*), its description and applicable rate of GST for each item in his techno-commercial bid.
- j) Statutory Variation in Taxes & duties as applicable at the time of supply shall be payable. However, in the event of no change in law but bidder quoting certain tax structure in bid document which is lower than the applicable one, such amount shall be the maximum amount of tax that can be claimed by bidder.
- k) **IMPORTED GOODS OFFERED BY INDIAN BIDDERS AGAINST DEALER INVOICE:** Wherever the material being offered is imported, the bidder must quote the prices inclusive of IGST. The rate and value of IGST as included in the price must be indicated separately. In case quantum of IGST is not mentioned by the bidder the same will not be considered for



BHARAT HEAVY ELECTRICALS LIMITED

HEEP-HARIDWAR, UTTARAKHAND (249403)

General Instructions and Standard Terms & Conditions for bidding against Tender Enquiry (GISTC)

For Indian Bidders (Version June-2021, Rev: 06)

evaluation. However, bidder will have to pass on the benefit of IGST to BHEL at the time supply.

- l) In case of directly dispatchable items to Customer's Site, BHEL-Haridwar will inform the GST registration number of the respective customer which must be mentioned on the vendor's invoice. Vendor to ensure availability of such information from BHEL-Haridwar before dispatch of any material. However, while filing GSTN-1, BHEL Haridwar GSTN number to be quoted.

Note: - Vendors must ensure compliance of all the applicable rules and procedure as envisaged in the GST Regime. Any loss to BHEL-Haridwar due to fault / non-compliance by the vendor will be to the vendor's account.

12. BANK GUARANTEE.

In case the bank guarantees are required to be deposited towards security deposit/performance guarantee or for any other purpose as per the terms of this tender enquiry, such bank guarantees of the requisite value in the denominated currency of the purchase order should be from one of the Indian branch of BHEL consortium banks and the bank guarantee should be in the proforma as prescribed by BHEL. The proforma of bank guarantee and the list of consortium banks are displayed at BHEL website www.bhelhwr.co.in. However, in case the bank guarantee is not from BHEL consortium banks, then the bidder has to get the bank guarantee confirmed from one of the Indian branch of BHEL consortium banks and the bank charges for such confirmation will be borne by the bidder.

13. GUARANTEE / WARRANTY AND CORRESPONDING REPAIRS / REPLACEMENT OF GOODS.

Goods shall comply with the specifications for material, workmanship and performance. Unless otherwise specified, the warranty shall be for a period of 18 months from the date of receipt. If the delivery is found non-compliant during the warranty period, leading to rejection, the Seller shall arrange free replacement / repair of goods, within one month from the date of intimation or any mutually agreed period. The rejected goods shall be taken away by the Seller at his cost and

replaced on Delivered Duty Paid (DDP) (FOR - BHEL Stores / designated destination basis) within such period. In the event of the Seller's failure to comply, Purchaser may take action as appropriate, including Repair / Replenish rejected goods & disposal of rejections, at the risk & cost of the Seller. In case the defects attributable to Seller are detected during processing of the goods at BHEL or at our subcontractor's works, the Seller shall be responsible for free replacement / repair of the goods as required by BHEL.

- b) **RETURN OF REJECTED MATERIAL FOR REPLACEMENT:** The bidder shall have to pay 5% incidental charges while taking back supplied material if it is found rejected on receipt. The rejected material shall be sent back only after receipt of replacement / submission of BG / refund of amount paid.

14. QUALITY REQUIREMENT.

Your bid / quotation should have specific confirmation regarding meeting all our quality requirements such as. (i) Test Certificate (TC), (ii) Guarantee Certificate (GC) / Warranty Certificate (WC), (iii) Quality Plan (QP) (if applicable); and (iv) Pre-Dispatch Inspection at your works (if applicable).

15. VALIDITY.

The quotation should be valid for a minimum period of 90 days effective from the date of opening of tender, unless otherwise specified in the tender enquiry.

16. RIGHT OF ACCEPTANCE.

- a) **BHARAT HEAVY ELECTRICALS LIMITED HARIDWAR** reserves the right to reject any or all the bids / quotations without assigning any reason thereof. BHEL also reserves the right to increase or decrease the tendered quantities. Bidders should be prepared to accept order for reduced quantity without any extra charges.
- b) Any discount / revised offer / bids submitted by a bidder on its own shall be considered, provided it is received on or before the due date and time of offer / bid submission (Part-1). Conditional discounts shall not be considered for evaluation of tenders.



BHARAT HEAVY ELECTRICALS LIMITED

HEEP-HARIDWAR, UTTARAKHAND (249403)

General Instructions and Standard Terms & Conditions for bidding against Tender Enquiry (GISTC)

For Indian Bidders (Version June-2021, Rev: 06)

- c) Unsolicited discounts / revised offers / bids given after Part-1 bid opening shall not be accepted. No change in price will be permitted within the validity period asked for in the tender enquiry.
- d) In case of changes in scope and / or technical specification and / or commercial terms & conditions having price implication, techno-commercially acceptable bidders shall be asked by BHEL to submit the impact of such changes on their price bids. In case a bidder opts to submit revised price bid instead of impact called for then the latest price bid shall prevail. However, in both situations, original price bid will be necessarily opened.
- e) The bidder whose bid is technically not accepted will be informed & EMD wherever submitted shall be returned after finalization of contract. EMD shall be forfeited in the event of bidder opting out after tender opening.
- f) BHEL reserves the right to short close the existing Purchase Order / Rate Contract / Work Order or any extension thereof at any stage.

17. TRANSIT INSURANCE.

- a) Transit Insurance will be covered by BHEL under its open Insurance Policy. Seller shall inform dispatch particulars (Purchase Order, RR /GR, Invoice value etc.) to "Finance department (Store bill Section), BHEL Ranipur, Haridwar (Uttarakhand-India) with value of consignment to the Purchaser within 07 days of dispatch for BHEL to arrange insurance coverage in its policy. Failure on the part of seller to inform dispatch particulars will make him liable to pay for any transit damages / losses suffered by the Purchaser.
- b) If Quoted Prices are inclusive of transit insurance, no weightage shall be given while evaluating the bids for Cost of Insurance, being in BHEL Scope.

18. RISK PURCHASE.

In case of abnormal delays (beyond the maximum late delivery period as per LD clause) in supplies / defective supplies or non-fulfillment of any other terms and conditions given in Purchase Order, BHEL may cancel the Purchase Order in full or part thereof, and may also make the purchase of such material from elsewhere / alternative source at the risk and cost of the supplier. BHEL will take all reasonable steps to get the material from alternate source at optimum cost. If bidder does not agree to the above Risk Purchase Clause, BHEL reserves the right to reject the offer. In case for compelling reasons BHEL accepts the offer without acceptance of this clause by the bidder and in the eventuality of Risk Purchase, appropriate action will be taken as per BHEL extant rules. This will be without prejudice to any other right of BHEL under the contract or under General Law.

19. FORCE MAJEURE CLAUSE.

Notwithstanding any other thing contained anywhere else in the contract or PO (Purchase Order), In case the discharge of obligation under the contract by either party is impeded or made unreasonably onerous, neither party shall be considered in breach of the contract to the extent that performance of their respective obligation is prevented by an event of Force Majeure that arises after the effective date (PO date).

In the above clause, Force Majeure means an event beyond the control of the parties to the contract which prevents a party from complying with any obligation of the contract including but not limited to:

- Act of God (Such as but not limited to earthquake, drought, tidal waves, floods etc.).
- War (whether war be declared or not), Hostilities Invasion, Act of foreign enemy etc.
- Rebellion, revolution, insurrection, civil war etc.
- Contamination of Radio Activity from any nuclear fuel or from any other nuclear waste or any other hazardous materials.
- Riots, commotions, strike unless restricted to the employees of supplier.
- Acts of terrorism.



BHARAT HEAVY ELECTRICALS LIMITED

HEEP-HARIDWAR, UTTARAKHAND (249403)

General Instructions and Standard Terms & Conditions for bidding against Tender Enquiry (GISTIC)

For Indian Bidders (Version June-2021, Rev: 06)

- g) Other unforeseeable circumstances beyond the control of the parties and which the affected party cannot avoid even by using its best efforts.
- h) Cancellation of contract by customer.
- i) Change in law / government. Regulation making the performance impossible.
- j) Pandemic or Epidemic.

The party claiming to be affected by force majeure shall notify the other party in writing immediately without delay on the intervention and on the cessation of such circumstances.

Irrespective of any extension of time, if an event of force majeure occurs and its effect continues for more than 180 days the affected party shall have right to cancel the contract.

As soon as reasonably practicable following the date of commencement of a Force Majeure Event, and within a reasonable time following the date of termination of a Force Majeure Event, either Party invoking it shall submit to the other Party reasonable proof of the nature of the Force Majeure Event and of its effect upon the performance of the Party's obligations under this Agreement.

The party shall, and shall ensure that its Subcontractors shall, at all times take all reasonable steps within their respective powers and consistent with Good Operating Practices (but without incurring unreasonable additional costs) to:

- a) Prevent Force Majeure Events affecting the performance of the party's obligations under this Agreement.
- b) mitigate the effect of any Force Majeure Event and
- c) Comply with its obligations under this Agreement.

If the war like situation has developed in a country where a seller's works is located in this P.O. or there is political instability and Indian Embassy located in that country forbids or advises for not having any business dealing with the sellers located in such zone / region/ country, then BHEL reserves the right to cancel the order.

20. NON-DISCLOSURE AGREEMENT.

All Drawing and Technical Documents relating to the product or it's manufacture submitted by one party to the other, prior or

subsequent to the formation of contract, shall remain property of the submitting party. Drawing, technical documents or other technical information received by one party, shall not without the consent of the other party, be used for any other purpose than that, for which they were provided. Such technical information shall not without the consent of the submitting party, otherwise be used or copied, reproduced, transmitted or communicated to a third party. Patterns supplied by BHEL will remain BHEL's property which shall be returned by the bidder on demand to BHEL. Bidder shall in no way share or use such intellectual property of BHEL to promote his own business with others or to gain a commercial advantage. BHEL reserves the right to claim damages from the bidder, or take appropriate action as deemed fit against the bidder, for any infringement of the provisions contained herein as available under law or equity.

21. SETTLEMENT OF DISPUTES / ARBITRATION.

In case of any dispute arising out of as in connection with this contract, the same shall be referred to arbitration under Arbitration & Conciliation Act 1996 of a sole arbitrator who shall be appointed by mutual consent of the parties. The seat & venue of arbitration shall be Haridwar.

The proceedings shall be conducted in English. The Governing law of contract shall be the substantive law of India.

22. WHARFAGE / DEMURRAGE RESPONSIBILITY.

In the event of delay in receipt of documents by Manager (Stores-Shipping) BHEL-Haridwar and in case where dispatches are made through Unapproved Transporter the sole responsibility for wharfage / demurrage for such delay shall be that of supplier.

23. CONDITIONS FOR AVAILING MICRO & SMALL ENTERPRISES (MSE'S) BENEFITS.

- a) "MSE Suppliers can avail the intended benefits only if they submit along with the offer, attested copies of either EM II certificate having deemed validity (**five years** from the date of issue of acknowledgement in EM II) or valid NSIC certificate or EM II certificate along with attested copy of a CA certificate



BHARAT HEAVY ELECTRICALS LIMITED

HEEP-HARIDWAR, UTTARAKHAND (249403)

General Instructions and Standard Terms & Conditions for bidding against Tender Enquiry (GISTC)

For Indian Bidders (Version June-2021, Rev: 06)

(Format enclosed at annexure-1 where deemed validity of EM II certificate of five years has expired) applicable for the relevant financial year (latest audited). Date to be reckoned for determining the deemed validity will be the date of bid opening (Part 1 in case of two-part bid) or vendor has to give Udyog Adhar Memorandum (UAM). Non submission of such documents will lead to consideration of their bid at par with other bidders. No benefit shall be applicable for this enquiry if any deficiency in the above required documents is found or the requisite documents are not submitted before price bid opening. If the tender is to be submitted through e-procurement portal, then the above require document are to be uploaded on the portal. Documents should be notarized or attested by a Gazetted officer. **UAM need not required to be notarized or attested.**

b) Any new supplier will be eligible for registration with BHEL as MSE supplier provided at least any one of the following documents are submitted along with application for registration: -

1. Udyog Adhar Memorandum (UAM).
2. Valid National Small Industries Commission (NSIC) Certificate.
3. Entrepreneurs Memorandum part II (EM II) certificate (valid based on deemed validity of 5 years) or
4. EM II certificate along with attested copy of CA Certificate (as per prescribed format at annexure-A) applicable for the relevant financial year (latest audited), where the deemed validity of EM II is over.
5. However, credentials of all MSE suppliers will be verified before advancing the intended benefits.
6. MSE bidders claiming SC/ST status will have to submit SC/ST certificate of the Proprietor from competent authority. Attested (notarized or attested by Gazetted officer) copy to be submitted along with the offer.
7. In case techno-commercial accepted bidders include MSE source and their prices (based on landed cost – considering quoted prices) are within the price band of 15% w.r.t. L-1 bidder, then BHEL can offer **25%** of quantity of respective item (rounded off to nearest number) to MSE bidders at L-1 price and in case, more than one MSE bidder is in 15 % band and the same is accepted by more than one MSE bidders then **25%** quantities of respective items will be considered for ordering on proportionate basis amongst MSE bidders.
8. There will be minimum of **3%** reservation for women owned MSEs within the above mentioned 25% reservation.
9. The reservation for MSEs owned by SC/ST will be **6.25%** { 25% out of target of 25% - refer para 4 of Public Procurement Policy for the Micro and Small Enterprises(MSEs)}.
10. The definition of MSEs owned by Women Entrepreneurs is clarified as under:
 - a) In case of proprietary MSE, proprietor shall be Woman.
 - b) In case of partnership MSE, the Woman partners shall be holding at least 51% of share in the unit.
 - c) In case of Private Limited companies, at least 51% share shall be held by Women promoters.
11. The definition of MSEs owned by SC/ST is clarified as under:
 - a) In case of proprietary MSE, proprietor(s) shall be SC/ST.
 - b) In case of partnership MSE, the SC/ST partners shall be holding at least 51% of shares in the unit.
 - c) In case of Private Limited companies, at least 51% share shall be held by SC/ST promoters.
12. While distributing the **25%** quantity amongst MSE bidders the decimal points in quantity shall be ignored for all the bidders except the L-1 amongst MSE bidders. Balance quantity after allocating the quantity to other MSE bidders ignoring the quantities in decimal, shall be given to L-1 (amongst MSE) bidder. However, if there are more than one MSE bidder at the same price level than preference for additional quantities due to ignoring off the decimal (as mentioned above) shall be given to the bidder offering favorable terms to BHEL and if the conditions offered are also same then preference will be given to the bidder having high SPR rating.
13. In case there are more than one MSE bidders (with different landed cost to BHEL) within 15% price band of lowest bidder and quantity to be offered is 1 no. only, then preference shall be given to the MSE bidder with lowest landed cost.
14. In case there are more than one MSE bidders (with same landed cost to BHEL) within 15% price band of lowest bidder and quantity to be offered is 1 no. only, then preference shall be given first, based on the favorable terms in the bid and in case terms are also same, the bidder with high SPR rating shall be given preference.
15. If L1 bidder is MSE bidder, entire quantity will be given to such MSE bidder only.

Quotations / Bids not in accordance with General Instructions and Standard Terms & Conditions are likely to be ignored.



BHARAT HEAVY ELECTRICALS LIMITED

HEEP-HARIDWAR, UTTARAKHAND (249403)

General Instructions and Standard Terms & Conditions for bidding against Tender Enquiry (GISTIC)

For Indian Bidders (Version June-2021, Rev: 06)

16. Note: It may however be noted that MSE guidelines as on date (Date of Technical Bid Opening Part-1) shall prevail.

17. "As per the OM No. F.No. 1(2)(1)/2016-MA dtd. 09.02.2017 issued from the Office of Development Commissioner (Micro, Small & Medium Enterprises), "Traders and agents should not be allowed to avail the benefits extended under the PP Policy."

In view of this, it is clarified that benefits of MSE (such as EMD Waiver, Tender fee exemption, Price preference, Payment preference etc.) will be given only to those MSE Vendors who are manufacturers of offered items against the NIT. No MSE benefits shall be provided to Agents / Stockists / Dealers / Traders etc. for the items offered but not manufactured by themselves."

24. INFORMATION TO THE BIDDERS.

a) Purchase related information is available at our Business-to-Business (B2B) Portal available on our website <https://hwr.bhel.com>. The user ID & password can be obtained by sending a request to concerned purchase executives.

b) Intimate your change in mail address or communication address or changes, if any, by email to AGM (SDX/MM) giving your bidder Code.

c) Please resolve your rejections and unexecuted overdue purchase order immediately which are posted at our B2B Portal, which can be visited through our site <https://hwr.bhel.com>

d) Copy of this Tender Enquiry is being sent through the post.

e) The Bidder declares that they will not enter into any illegal or undisclosed agreement or understanding, whether formal or informal with other bidder(s). This applies in particular to prices, specifications, certifications, subsidiary contracts, submission or non-submission of bids or any other actions to restrict competitiveness or to introduce cartelization in the bidding process.

In case, the bidder is found having indulged in above activities, suitable action shall be taken by BHEL as per extant policies/guidelines.

f) Supplier must upload digitally signed e-Invoice on B2B portal for processing of Bills.

In other cases, inked signed hard copy of Invoice to be submitted for processing of Bills.

25. MAKE IN INDIA (GOVT-NOTIFICATION).

A. This tender enquiry shall be governed by notification no. P-45021/2/2017-PP (BE-II) dated 04.06.2020 of government of INDIA and subsequent circulars issued afterwards. Accordingly, the minimum local content, the margin of purchase preference and the procedure for preference to make in INDIA shall be adhered.

B. The margin of purchase preference shall be 20%.

- 'Class-I local Supplier' means a supplier or service provider, whose goods, services or works offered for procurement, has local content equal to or more than 50%, as defined under this order.
- 'Class-II local Supplier' means a supplier or service provider, whose goods, services or works offered for procurement, has local content more than 20% but less than 50%, as defined under this order.
- 'Non- local Supplier' means a supplier or service provider, whose goods, services or works offered for procurement, has local content less than or equal to 20%, as defined under this order.

C. Vendor to specifically confirm if they are Class-I or Class-II local supplier or not as per above mentioned notification. Accordingly, the 'Class-I local supplier' / 'Class-II local Supplier' at the time of tender, bidding or solicitation shall be required to indicate percentage of local content and provide self-certification that the item offered meets the local content requirement for 'Class-I local supplier' / 'Class-II local Supplier', as the case may be. They shall also give details of the location(s) at which the local value addition is made.

D. In cases of Procurement for a Value in Excess of Rs. 10 Crores, the 'Class-I local supplier' / 'Class-II local Supplier' shall be required to provide a Certificate from the Statutory Auditor or Cost Auditor of the Company (in the case of companies) or from a practicing Cost Accountant or practicing Chartered Accountant (in respect of suppliers other than companies) giving the percentage of Local Content.



BHARAT HEAVY ELECTRICALS LIMITED

HEEP-HARIDWAR, UTTARAKHAND (249403)

General Instructions and Standard Terms & Conditions for bidding against Tender Enquiry (GISTC)

For Indian Bidders (Version June-2021, Rev: 06)

E. Requirement of Purchase Preference:

Purchase preference shall be given to 'Class-I local supplier' in procurements undertaken by procuring entities in the manner specified hereunder -

a. In the procurements of goods or works, which are covered by para 3(b) of mentioned Govt. circular and which are divisible in nature, the 'class-I local supplier' shall get purchase preference over 'Class-II supplier' as well as 'Non-local supplier', as per following procedure:

- i. Among All qualified bids, the lowest bid will be termed as L1. If L1 is 'Class-I local supplier', the contract for full quantity will be awarded to L1.
- ii. If L1 bid is not a 'Class-I local supplier', 50% of the order quantity shall be awarded to L1. Thereafter, the lowest bidder among the 'Class-I local supplier' will be invited to match the L1 price for the remaining 50% quantity subject to the class-I local supplier's quoted price falling within the margin of purchase preference, and contract for that quantity shall be awarded to such 'Class-I local supplier' subject to matching the L1 price. In case such lowest eligible 'Class-I local supplier' fails to match the L1 price or accepts less than the offered quantity, the next higher 'Class-I local supplier' within the margin of purchase preference shall be invited to match the L1 price for remaining quantity and so on, and contract shall be awarded accordingly. In case some quantity is still left uncovered on Class-I local supplier, then such balance quantity may also be ordered on the L1 bidder".

b. In the procurements of goods or works, which are covered by para 3(b) of mentioned Govt. circular and which are not divisible in nature, and in procurement of services where the bid is evaluated on price alone, the 'class-I local supplier' shall get purchase preference over 'Class-II supplier' as well as 'Non-local supplier', as per following procedure:

- i. Among all qualified bids, the lowest bid will be termed as L1. If L1 is 'Class-I local supplier', the contract will be awarded to L1.
- ii. If L1 is not 'Class-I local supplier', the lowest bidder among the 'Class-I local supplier', will be invited to match the L1 price subject to Class-I local supplier's quoted price falling

within the margin of purchase preference, and the contract shall be awarded to such 'Class-I local supplier' subject to matching the L1 price.

- iii. In case such lowest eligible 'Class-I local supplier', fails to match the L1 price, the 'Class-I local supplier' with the next higher bid within the margin of purchase preference shall be invited to match the L1 price and so on and contract shall be awarded accordingly. In case none of the 'Class-I local supplier' within the margin of purchase preference matches the L1 prices, the contract may be awarded to the L1 bidder.

c. 'Class-II local supplier' will not get purchase preference in any procurement, undertaken by procuring entities.

F. For this procurement, the local content to categorize a supplier as a Class-I local supplier/ Class-II local supplier/ Non-local supplier and purchase preference to Class-I local supplier, is as defined in Public Procurement (Preference to Make in India), Order 2017 dated 04.06.2020 issued by DPIIT. In case of subsequent orders issued by nodal ministry, changing the definition of local content for the items of the NIT, the same shall be applicable even if issued after issue of this NIT, but before opening of Part-II bids against this NIT.

G. Procurements where estimated value to be procured is less than Rs. 5 lakhs shall be exempted from GOI order No. P-45021/2/2017-PP (BE-II) dated 04.06.2020.

H. For procurement of Goods & Services which are divisible in nature, following shall be operated for **MSE bidders** under Public procurement Policy for the Micro and Small Enterprises (MSEs) Amendment Order, 2019, Ref. No. AA:SSP: MSE: Amndt, dtd. 30.11.2018, Circular No. 44 of 2018-19;-

a. If L1 bid is not from "Class-I local Supplier" and price quoted by MSE bidder falls within the margin of Purchase preference (L1+15% for MSEs), then 25 % of total order quantity of respective item (rounded off to nearest number) shall be awarded to MSE bidder, subject to MSE bidder matching the L1 Price. Out of Remaining 75% quantity, distribution shall be operated as per below sub-clause (2) –

b. If "Class- I Local Supplier" (Next to L1, other than MSE) quoted price falling within the Margin of Purchase Preference, and "Class-I local supplier" matches the L1 price,



BHARAT HEAVY ELECTRICALS LIMITED

HEEP-HARIDWAR, UTTARAKHAND (249403)

General Instructions and Standard Terms & Conditions for bidding against Tender Enquiry (GISTC)

For Indian Bidders (Version June-2021, Rev: 06)

then 50% of remaining Quantity (after allocation of 25% to MSE) i.e. 37.5% shall be awarded to local supplier and 37.5% shall be awarded to foreign bidder.

Note: L1 Price refers to lowest evaluated / landed cost to Company.

For Further details, please refer GOI order no. P-45021 / 2 / 2017 - PP (BE-II) dated 04.06.2020.

26. RESTRICTIONS UNDER RULE 144(XI) OF THE GENERAL FINANCIAL RULES (GFRs), 2017

All provisions of Order No. F.No.6/18/2019-PPD of Department of Expenditure (DoE) shall be applicable for this tender enquiry (Order copy is available at <https://doe.gov.in/procurement-policy-divisions>). Accordingly, any bidder from a country which shares a land border with India (except the countries to which the Govt. of India has extended lines of credit or in which the Govt. of India is engaged in development projects for which list is available at <https://www.mea.gov.in/>) will be eligible to bid in this tender only if the bidder is registered with the Competent Authority as specified in Annex I of the said Order of DoE.

Updated list of the countries to which lines of credit have been extended or in which development projects are undertaken are available on the Ministry of External affairs website (<https://www.mea.gov.in/>)

For the purpose of this order, definition of Bidder from a country which shares a land border with India shall be same as defined in the Annex III of the said order.

Registration with the competent authority as stipulated in the said order is responsibility of bidder. Bidder has to submit a certificate certifying following along with offer:

"I have read the clause regarding restrictions on procurement from a bidder of a country which shares a land border with India; I certify that bidder (.... Name of Bidder) is not from such a country or, if from such a country, has been registered with the Competent Authority. I hereby certify that bidder (.....Name of bidder) fulfils all requirements in this regard and is eligible to be considered"

If the bidder is from such country which shares a land border with India evidence of valid registration by the Competent Authority shall also be attached along with offer."

27. NOTE.

- a) Special conditions of enquiry, if enclosed by BHEL, will supersede the respective standard / general terms of enquiry.
- b) Any other Standard terms and Conditions of the bidder attached / referred against the tender enquiry will be treated as null and void ab initio.
- c) In order to protect the commercial interests of BHEL, it becomes necessary to take action against suppliers / contractors by way of suspension of business dealings, who either fail to perform or are in default without any reasonable cause, cause loss of business / money / reputation, indulged in malpractices, cheating, bribery, fraud or any other misconducts or formation of cartel so as to influence the bidding process or influence the price etc. Guide- lines for Suspension of Business Dealings with Suppliers / Contractors shall prevail over which is available at BHEL website <http://www.bhel.com>
- d) The bidder along with its associate / collaborators / sub-contractors / sub-vendors / consultants / service providers shall strictly adhere to BHEL Fraud Prevention Policy displayed on BHEL website <http://www.bhel.com> and shall immediately bring to the notice of BHEL-Management about any fraud or suspected fraud as soon as it comes to their notice.
- e) "BHEL shall recover the amount of compensation paid to victim(s) by BHEL towards loss of life / permanent disability due to an accident which is attributable to the negligence of contractor, agency or firm or any of its employees as detailed below;
 1. **Victim:** Any person who suffers permanent disablement or dies in an accident as defined below.
 2. **Accident:** Any death or permanent disability resulting solely and directly from any unintended and unforeseen injurious

Quotations / Bids not in accordance with General Instructions and Standard Terms & Conditions are likely to be ignored.



BHARAT HEAVY ELECTRICALS LIMITED

HEEP-HARIDWAR, UTTARAKHAND (249403)

General Instructions and Standard Terms & Conditions for bidding against Tender Enquiry (GISTC)

For Indian Bidders (Version June-2021, Rev: 06)

occurrence caused during the manufacturing / operation and works incidental thereto at BHEL factories/ **offices and precincts** thereof , project execution , erection and commissioning, services, repairs and maintenance, trouble shooting, serving , overhaul, renovation and retrofitting , trial operation, performance guarantee testing undertaken by the company or during any works / during working at BHEL Units/ Offices/ townships and premises/ project sites.

3. Compensation in respect of each of the victims:

- (i) In the event of death or **permanent disability** resulting from **Loss of both limbs**: Rs. 10,00,000/- (Rs. Ten Lakh).
- (ii) In the event of **other permanent disability**: Rs. 7,00,000/- (Rs. Seven Lakh).

4. Permanent Disablement: A disablement that is classified as a permanent total disablement under the proviso to Section 2(l) of the Employees Compensation Act, 1923.”

f) The bidder shall be in compliance with applicable laws, rules and regulations throughout the terms of the contract for conducting its business generally and to perform its obligations under this contract.