

BHARAT HEAVY ELECTRICALS LIMITED
RAMACHANDRAPURAM: HYDERABAD-502032

LOGISTICS DEPARTMENT
TELEPHONE NO. 040-2318 2162

TENDER NOTICE

Tender Notice No: HY/LOG/PKG/2022/01, Dt.21.12.2021

(PR- 1600025280)

1. Bharat Heavy Electricals Limited, a Government of India Public Sector undertaking having its Registered Office at Siri Fort, New Delhi. BHEL Ramachandrapuram, one of its manufacturing Units, invites sealed bids from eligible /Contractors, who fulfill qualification criteria as stipulated in NIT, for the work, “**Packing of finished goods in Logistics**”.
2. The tender documents are available in the BHEL Web Site www.bhel.com or **Central Public Procurement Portal (CPP Portal)** with link (<https://eprocure.gov.in/eprocure/app>) & <http://eprocure.gov.in>. Being e-tender, the Techno-Commercial Bid and Price Bid will be submitted online through e-tender portal. The bidders shall be required to submit their offers in 2 separate parts: Part-A - Techno-Commercial Bid along with RTGS/NEFT for EMD and Part-B - Price Bid. Both bids are to be duly signed, stamped, scanned and to be uploaded in online tendering portal. Hard copy of offer is not required to be submitted to BHEL-HPEP. Any offer received in Hard copy shall not be accepted and straightway rejected by BHEL-HPEP.
3. All corrigenda, addenda, amendments, time extensions, clarifications etc. to the tender will be hosted on www.bhel.com or **CPP portal** only.

CONTENTS

SL. No.	Description
1.0	Notice Inviting Tender
1.1	Techno-Commercial bid
2.0	Prequalification requirements
3.0	Instructions to Tenderer
3.31	Taxes & Duties – GST Clauses
4.0	General terms and conditions
4.1	Eligibility Criteria
5.0	Earnest Money Deposit
6.0	Security Deposit
7.0	Statutory Requirement
8.0	Manpower
9.0	Safety
10.0	Period of Contract
11.0	Failure to comply with Contract
12.0	Payment to the Contractor
13.0	Sub-contracting
14.0	Laws governing the Contract
15.0	Legal Jurisdiction
16.0	Duties & Responsibilities of Contractor
17.0	Contract Work Description
18.0	Special Terms & Conditions of Contract
19.0	Evaluation of Price Bid
20.0	Terms and conditions of Contract Agreement
21.0	Special Instructions
22.0	MSME Supplier
23.0	Price Bid
24.0	Declaration by tenderer

1.0 NOTICE INVITING TENDER

- i. Tender Number & date : HY/LOG/PKG/2022/01 Dt. 21.12.2021
- ii. Name of the Work : Packaging of finished goods at Logistics
- iii. EMD : Rs 1.71 Lakhs
- iv. Approximate estimated value of work : Rs. 85,36,805/-
- v. Last date for sale of tender documents : NA
- vi. Last date for receipt of tender : Visit e- procurement portal
- vii. Date, time and place of tender opening : Visit e- procurement portal
- viii. Period of contract : 12 months from date of awardal
- ix. Maintenance period : Nil
- x. Website for online bid submission : (<https://eprocure.gov.in/eprocure/app>) & <http://eprocure.gov.in>

KINDLY NOTE THAT ONLY ONLINE BID WILL BE CONSIDERED AGAINST THIS TENDER.

1.1 TECHNO-COMMERCIAL BID

To,
 Bharat Heavy Electricals Limited
 H.P.E.P., RC PURAM,
 HYDEDRABAD-32

Dear Sir,

I / We hereby offer to carry out the work '-----' against Tender Enquiry No. -----

I /We have carefully perused the following documents connected with the above mentioned work and agree to abide with the same.

- 2.0 Prequalification requirements
- 3.0 Instructions to Tenderer
- 3.31 Taxes & Duties – GST Clauses
- 4.0 General terms and conditions
- 4.1 Eligibility Criteria
- 5.0 Earnest Money Deposit
- 6.0 Security Deposit
- 7.0 Statutory Requirement
- 8.0 Manpower
- 9.0 Safety
- 10.0 Period of Contract
- 11.0 Failure to comply with Contract
- 12.0 Payment to the Contractor
- 13.0 Sub-contracting
- 14.0 Laws governing the Contract
- 15.0 Legal Jurisdiction
- 16.0 Duties & Responsibilities of Contractor
- 17.0 Contract Work Description/Scope of work
- 18.0 Special Terms & Conditions of Contract
- 19.0 Evaluation of Price Bid
- 20.0 Terms and conditions of Contract Agreement
- 21.0 Special Instructions
- 22.0 Guidelines for Reverse Auction
- 23.0 MSME Supplier
- 24.0 Declaration by Tenderer

} (Part –A)

Note: EMD & Tender document cost which is in the form of RTGS/NEFT shall be enclosed in Part –A only

25.0 Price Bid (Part – B)

I/ We further agree to execute all the works referred to in the said documents as per the General terms and conditions.

I am / We are in possession of independent PF/ESI Code.

I/We undertake to obtain applicable the PF/ESI coverage of all our workmen to be deployed for the above work and also agree for recovery of appropriate PF/ESI contribution from wages/bills

Strike out which is not applicable

Signature of Tenderer

PART - A
TECHNICAL BID

Tender Enquiry No. :

Date:

I. Details of the Contractor:

a) Name and address of the Firm:

Contact person

Vendor code (if already allotted by BHEL)

Phone/Mobile No.

E-mail ID

b) Name and address of the proprietor/Director/partners:

c) Is any contract being operated under the control of the tenderer in BHEL . Yes / No
(If yes furnish the details):

	<u>Location/ Address</u>	<u>Value</u>	<u>Date of Completion</u>
1.			
2.			
3.			
4.			

d) Is any relative of tenderer employed in BHEL Yes / No
(If yes Furnish the detail)

Name	Staff no	Location / Area

Signature of the Tenderer
Date:

II. The contractor shall confirm the enclosure of all the below documents without which tenderer may not be eligible to participate in the tender:

01	ESI Code No. (enclose copy of ESI code allotment letter of ESI authority)	
02	PAN No.	
03	PF Code No. (enclose copy of PF code allotment letter of EPF authority)	
04	GST REGISTRATION NUMBER	
4.1	State in which registered	
4.2	Type of GST Registration : Composite or Regular (Indicate Composite or Regular)	
4.3	Whether Casual Taxable person or non-resident taxable person or regular taxable person	
4.4	Place from where the services are rendered	
05	Banker's Name & Address	
06	Bank A/C No. & Branch	
07	Have you quoted rates for all the activities, as indicated in the price bid (Part – B)	YES / NO
08	Financial Turnover for preceding three years duly certified by qualified Chartered Accountant: i.e. FY 2018-19, 2019-20 & 2020-21	Financial Years 2018-19 2019-20 2020-21
09	Details of EMD (Payment proof through RTGS/NEFT shall be uploaded).	Amount : RTGS/NEFT Ref: Bank Name:- Branch:-
10	Particulars of Experience/Credentials As per pre-qualification requirements. (Work completion certificates to be enclosed) If vendor submits Pvt. Company experience, the following documents should be submitted along with technical bid: Awardal Copy, Agreement Copy and TDS. Otherwise bid will be liable for rejection.	
11	Labour License(State/Central) Validity up to In case not available, bidder shall submit the License before commencement of the work.	
12	Reverse Auction acceptance? Yes/No	

Signature of the Tenderer

2.0 PRE-QUALIFICATION REQUIREMENTS:

The following conditions have to be satisfied by the tenderer, with documentary proof to be enclosed with tender bid (Technical):

i) Average annual financial turnover during the last 3 years, ending 31st March of the previous financial year (should submit balance sheet & P&L account for last 3 years – certified by Chartered Accountant), should be at least 30% (Rs.25.61 lakhs) of the estimated cost. Further, the tenderer fails to submit the figure (s) for 3 years, non-submitted year will be considered as “0” (Zero) for averaging the turnover. In the 3 years’ turnover, previous year turnover is compulsory.

ii) Particulars of experience / credentials for the works executed of similar nature during last 7 years (Completion and experience certificate of the works to be enclosed) ending last day of month previous to the one in which applications are invited should be either of the following:

a. Three similar completed works each costing not less than the amount equal to 40% (each work Rs.34.15 lakhs) of the estimated cost.

OR

b. Two similar completed works each costing not less than the amount equal to 50% (each work Rs.42.68 lakhs) of the estimated cost.

OR

c. One similar completed work costing not less than the amount equal to 80% (each work Rs.68.29 lakhs) of the estimated cost.

Similar Work:- Execution of wooden/steel packing works in any industry will be considered as similar work.

(If the experience certificates for above similar work are submitted from the private organizations then for executed value either TDS certificate is to be submitted as a proof of payment).

iii) Experience certificate issued by BHEL, RC Puram in case any work executed in BHEL, RC Puram for past three years. Any adverse remarks in the experience certificate will be a disqualification factor.

iv) The firms/vendors/contractors who are in the BHEL banned list are not eligible to participate in this tender. The offers received from such firms/vendors/contractors will be rejected. The list of banned firms is available on BHEL website www.bhel.com.

v) Valid ESI Code Number and P.F. Code Number

vi) GST Registration number (Copy of GST registration to be enclosed).

vii) PAN No. (In case not available, proof of having applied with acknowledgement from concerned authority).

viii) Labour licence (Central/State Government): (proof of having Code No: to be Enclosed, In case not available, bidder shall submit the License before commencement of the work).

3.0 INSTRUCTIONS TO TENDERER

- 3.1 Tender is a two part bid system. The tender documents consist of Part – A and Part - B as detailed below:
 Part ‘A’: Techno-commercial Bid along with RTGS/NEFT for EMD(Bidder shall submit proof of EMD payment). The bidders shall be required to submit their offer through online only with duly signed, stamped, scanned and to be uploaded in (<https://eprocure.gov.in/eprocure/app>) & <http://eprocure.gov.in>.
 Part ‘B’: Price Bid shall be submitted duly signed, scanned and to be uploaded in above mentioned CPP portal.
- 3.2 The tenderer shall not indicate the price or rate in PART-A: Techno-commercial bid. The tenderer shall expressly accept all the terms and conditions of the Tender. The tender which does not comply with the BHEL’s Terms & Conditions may be rejected as Non-responsive/non-conforming and non-acceptable.
- 3.3 Part ‘B’ – Price Bid should not carry any conditions. Price / rate should be quoted in clear terms in the format given by BHEL. Price bid will be opened in respect of those tenderers who are qualified in Techno-Commercial Bid.
- 3.4 **The tender forms both Part ‘A’ & ‘B’ duly filled in all respects shall be signed & stamped on each page by the tenderer. Any alteration, erasure or over-writing will render the tender invalid. However, alteration neatly carried out and duly attested over with the full signature of the tenderer is permitted.**
- 3.5 The tenderer should submit the tender documents intact without detaching any page or pages.
- 3.6 Before making the offer, the tenderers are advised to carefully go through the terms and conditions, which form part of the Agreement.
- 3.7 All entries in the tender document should be in one Ink. Corrections, over writing, cuttings etc. are not permitted. All the columns in the tender form should be filled without leaving any column blank in any page of the tender. In case any of the columns is left blank, the tender would be rejected.
- 3.8 The price/rate should be quoted in figures as well as in words.
- 3.9 For any further details required, AGM/Logistics, BHEL, RC Puram, Hyderabad-32 may be contacted in person or through Telephone Nos. 040-23185115.
- 3.10 BHEL reserves the right to assess the capacity and capability of the parties for pre-qualification. The company also reserves the right to accept or reject any or all the tenders or any part thereof at any stage of process without assigning any reason whatsoever. The company has no obligation to accept the lowest tender. Offer of the Tenderer if prima-facie found not comparable with the quantum of work envisaged and the bid is a desperate effort to be L1, then the offer is liable to be rejected. BHEL's decision in this regard shall be final and binding.
- BHEL reserves the right to reject the tender of bidder, who committed default and having bad track record in execution of previous contracts in BHEL. For the purpose of this clause default and bad track record means violation of labour laws (such as non-payment of wages within time, non-payment of ESI, PF contribution, payment of bonus) and backing out from contract after reverse auction or after receipt of LOI / entering of agreement etc.
- 3.11 PRICE BID - The tenderers are required to submit their quotation for all the items listed in the Price Bid format. The service charge % should be quoted on total estimated amount after careful study of the actual job requirement so that, in case the contract is awarded, contractor should not express any difficulty in execution of the contract.
- 3.12 The Minimum Wages prevailing at BHEL R.C.Puram consists of State Basic +State DA and Additional payments (herein after referred as BHEL fair wages) from time to time are payable to workmen. The tenderer would be required to pay allowances/incentives as decided and communicated by BHEL.
- 3.13 VALIDITY OF RATES: The price bid validity quoted should be valid for 120 days initially from the date of opening of the Techno-Commercial bid.
- 3.14 Tender document cost and Earnest Money deposit via RTGS/NEFT shall be enclosed to the techno-commercial bid only. Otherwise the offer will not be considered.
- 3.15 The tenderers are advised to inspect the site of work and its environments and be well acquainted with the actual working and other prevailing conditions, position of materials and labour related procedures & practices adopted in BHEL.
- 3.16 i) The firms/vendors/contractors who are in the BHEL banned list are not eligible to participate in this tender. The offers received from such firms/vendors/contractors will be rejected. The list of banned firms is available on BHEL website www.bhel.com.
 ii) Execution of contract, Bill verification, certification for payments and forward to Accounts department along with HR/IR clearance certificate for effecting payment etc. will be done by respective user departments only.

3.18 DISCREPANCY IN WORDS & FIGURE QUOTED IN PRICE BIDS:

i) If there is an error in a total corresponding to the addition or subtraction of subtotals, the subtotals shall prevail and the total shall be corrected;

ii) If there is a discrepancy between words and figures, the amount in words shall prevail, unless the amount expressed in words is related to an arithmetic error, in which case the amount in figures shall prevail subject of (i) above

iii) If there is such discrepancy in an offer, the same shall be conveyed to the bidder with target date up to which the bidder has to send his acceptance on the above lines and if the bidder does not agree to the decision of the purchaser, the bid is liable to be ignored

3.19 BHEL reserves the right to award the contract to one or more contractors simultaneously as deemed fit at the initial stage or during the contract period.

3.20 BHEL reserves the right to reject any bid, which is technically unacceptable and unworkable. Further, BHEL also reserves the right to reject any or all tenders without assigning any reasons thereof.

3.21 BHEL reserves the right to cancel the contract at the initial stage or during the contract period without assigning any reason to the tenderer.

3.22 Wherever prescribed formats are specified for the tenderers use, he shall use the same for making his Claims.

3.23 Tender document should be complete in all respects.

3.24 Successful tenderers shall enter into an Agreement on stamp paper of Rs.200/- for having accepted the rates, terms and conditions of the contract as per the pro-forma given by BHEL.

3.25 The Offers should be in full conformity with the terms and conditions of this tender. No contra conditions are acceptable. Incorrect and incomplete tenders are liable to be rejected. Tenders not submitted in the prescribed forms will be rejected.

3.26 BHEL reserves the right to accept or reject any tender in part or full at their discretion without assigning any reason.

3.27 If a tenderer deliberately gives wrong information in his tender or creates conditions favorable for the acceptance of his tender, then BHEL reserves the right to reject such tender at any stage.

3.28 If the tenderer indulges in any unethical practice for securing the contract, the offer of such tenderer shall be rejected.

3.29 Any written communication required to be sent to the contractor in writing shall be sent at the address mentioned on the tender form or to any other address subsequently intimated by Contractor in writing to BHEL HPEP for the contract purposes or to his e-mail address.

3.30 SITE VISIT:

a. Before quoting, the tenderers are advised to inspect the site of work and its environments and be well acquainted with the actual working and other prevailing conditions, position of materials and labour related procedures including payments, billing and practices etc.

They should be well versed with BHEL General Conditions of Contract, Instructions to tenderers, drawings wherever applicable and specifications and all other documents which form part of the agreement to be entered into subsequent to award of work. The tenderers shall specially note that it is the tenderer's responsibility to provide any item which is not specially mentioned in the specification or drawing, but which is necessary to complete the work

b. The tenderer/Bidder and any of his authorized personnel or agents will be granted permission by the BHEL to enter upon its premises and lands for the purpose of site visit. However the bidder shall express condition that he, his personnel, and agents will be responsible against all liability in respect thereof, including death or personal injury, loss of or damage to property, and any other loss, damage, costs, and expenses incurred as a result of the inspection.

c. The Bidder should inform the BHEL at least 2 days (time may be fixed in consultation with tender issuing authority) in advance about the proposed site visit. The Bidder, at his own responsibility and risk is encouraged to visit, inspect and survey the Site and its surroundings and satisfy himself before submitting his bid as to the form and nature of the Site, the means of access to the Site, the accommodation he may require, etc.

d. In general, Bidders shall themselves obtain all necessary information. A Bidder shall be deemed to have full knowledge of the Site, whether he inspects it or not and no extra claims due to any misunderstanding or otherwise shall be allowed. The cost of visiting the Site shall be at the Bidders' own expense. Any deviations of information in the report and the actual site will not be the responsibility of the BHEL.

3.31 Taxes & Duties- GST Clauses

- a) In case GST credit is delayed/denied to BHEL due to non/delayed receipt of goods and/or tax invoice or expiry of timeline prescribed in GST law for availing such ITC, or any other reasons not attributable to BHEL, GST amount shall be recoverable from vendor along with interest levied/leviable on BHEL.
- b) In case vendor delays declaring such invoice in his return and GST credit availed by BHEL is denied or reversed subsequently as per GST law, GST amount paid by BHEL towards such ITC reversal as per GST law shall be recoverable from vendor/contractor along with interest levied / leviable on BHEL.
- c) The bidder shall arrange to send to BHEL, Hyderabad along with all the required documents as in Purchase Order, Tax Invoice (Original for Recipient) along with his bills.
- d) Vendor to ensure correct applicability of IGST/CGST/SGST/UTGST based on the Inter / Intra state movement Supply of goods and services or both.
- e) Taxes and duties prevalent on the contractual delivery date or the actual delivery date (in case of delay) whichever is lower shall be applicable paid. Composition Scheme to be addressed.
- f) Vendor shall note that the Invoice has to be raised quoting HSN Code of Goods or Accounting Code of Services or both wherever applicable.
- g) Invoice should mention BHEL-HPEP-HYDERABAD GSTIN: 36AAACB4146P1ZG or GSTIN of BHEL Nodal Agency as mentioned in PO.
- h) In case of any short supply of goods or service Vendor has to raise a credit note for short supplied quantity as per GST provisions.
- i) Any GST liability arising on BHEL under reverse charge before actual receipt of goods and or services and/or invoice thereof would be subject to recovery of interest leviable for the period between the date of such liability and actual date of eligibility of ITC based on receipt of goods, receipt of invoices and other conditions specified in GST law, as applicable.
- j) **Penalty clause:** 0.50 % of the value of work or part thereof will be levied for every week delay in Initial deployment of requisite man power from the date of issue of LOI/Commencement of work subject to a maximum of 10 % value of the work. Penalty amount so determined along with applicable GST thereon shall be recovered. In addition, other performance related penalties shall be applicable as per the description given below and amount of penalty will be calculated on daily basis and this amount will be deducted from running bill on monthly basis.

Packing Activity:

SL No.	Description of Irregularities	Penalty
1	For delay in performance of work.(A-Packing Activity)	As per Annexures II
2	For not wearing uniform, safety shoe, helmet etc. by the laborers.	Rs.50/- per day per workman.

- k) Supplier shall mention their GSTN registration number in all their invoices and invoices shall be in the format as specified/prescribed under GST laws. Invoices shall necessarily contain Invoice number (in case of multiple numbering system is being followed for billing like SAP invoice no, commercial invoice no etc., then the Invoice No which is linked/uploaded in GSTN network shall be clearly indicated), item description as per PO, Quantity, Rate, Value, applicable taxes with nomenclature (like IGST, SGST, CGST & UTGST) separately, HSN/ SAC Code, etc.
- l) A declaration to the effect that all tax liability as per GST rules and regulations shall be discharged.

4.0 GENERAL TERMS AND CONDITIONS

- 1) Contractor shall obtain Labour License (Central / State Government) before commencement of work as applicable.
- 2) In case Contractor engages labour from outside Telangana State to execute the said work, he is required to obtain license under Inter State Migrant Workmen (RE&CS) Act 1979
- 3) BHEL reserves the right to split up the work into convenient portions and award them to different contractors.
- 4) The tenderer shall keep the contents of his tender and rates quoted by him to be kept confidential
- 5) All expenses in preparation and submission of bids and visits to the office or any place in connection with the preparation of Bid shall be borne by Bidder. BHEL in no case shall be responsible or liable for these costs regardless of the outcome of the Bidding process
- 6) The bid prepared by the Bidder including all correspondence etc. relating to his offer/ bid shall be in ENGLISH language.

- 7) No interest shall be payable by BHEL on earnest money or security deposit or any money due to the contractor by BHEL.
- 8) The BHEL Bank account details for payment of EMD through RTGS/NEFT mode is as follows:

BANK ACCOUNT DATA FOR RTGS/NEFT MODE OF PAYMENT

1. Party Code

2. Option : RTGS/NEFT

3. Beneficiary Details:

A) Name of Beneficiary : BHARAT HEAVY ELECTRICALS LIMITED

B) Address : RAMACHANDRAPURAM, HYDERABAD- 502032.

C) Bank Name : STATE BANK OF INDIA

D) BRANCH NAME : BHELTOWNSHIP, HYDERABAD- 502032.

E) Account No. : 62048154115

F) Account type : Current A/c

G) Bank IFSC Code : SBIN0020075

H) Bank MICR Code : 500002370

4.1 ELIGIBILITY CRITERIA

- 4.1.1 In case the contractor is a Partnership Firm or a Company, the same should be a registered under the relevant Indian Partnership Act 1932 or Companies Act, 1956 and well established organization having at least three years existence in business consecutively for the past three years.
- 4.1.2 The Successful tenderer has to get the license from Labour Dept., under Contract Labour (Regulation & Abolition) Act 1970 for the areas and nature of work, which they will be performing as part of the contract.
- 4.1.3 Tenderer should have independent ESI Employer code under ESI Act 1948.
- 4.1.4 Tenderer should have independent PF code under Employee Provident Fund and Miscellaneous Provisions Act 1952.
- 4.1.5 Photocopy of letter from ESI Corp. and PF Commissioner's Office to establish that tenderer is independently registered as an employer under ESI and PF to be produced.
- 4.1.6 The tenderer shall also mention the PAN Number issued by Income Tax Department, copy of the PAN card or PAN number allotment letter shall be submitted along with the tender documents.
- 4.1.7 There should be no litigation or charge under investigation / enquiry / trial against the Tenderer, or conviction in a court of law or suspension or blacklisting by any organization on any ground. Tenderer shall confirm this in the Declaration. During the course of work, if any such information comes to light, the contract may be terminated.
- 4.1.8 The opinion / decision of BHEL regarding the bid shall be final and conclusive. BHEL reserves the right to reject any or all the bids at any time without assigning any reason.
- 4.1.9 In case the tenderer has a relative employed in BHEL, the authority inviting tender shall be informed of this fact in writing at the time of submission of tender, failing which the tender may be disqualified, or if such fact comes to light subsequently, the contract may be terminated.
- 4.1.10 For the works which are continuous in nature, and which require regular interaction and monitoring, the contractor shall have an Office/Establishment in Hyderabad.

5.0 EARNEST MONEY DEPOSIT:

- 5.1 An amount of Rs.1,71,000/- (Rupees One Lakh Seventy One Thousand only) towards EMD shall be paid by RTGS/NEFT on any nationalized bank / scheduled bank to BHEL bank account and shall be enclosed to the tender bid. No other means of payment shall be accepted. EMD / any money due to the tender by BHEL shall not carry any interest
- 5.2 Tenders received without EMD as specified above shall be rejected. If EMD accompanies price bid, such bids shall not be considered and will be rejected. If EMD is not in line with amount called for, the EMD as well as the quotations will be returned and unopened to the tenderers.
- 5.3 EMD of unsuccessful bidders shall be returned promptly upon award of Contract and EMD of successful bidder will be returned upon the bidder's accepting the contract and furnishing the requisite security deposit.
- 5.4 EMD by the Tenderer will be forfeited as per NIT conditions, if:

- i) After opening the tender and within the offer validity period, the tenderer revokes his tender or makes any modification in his tender which is not acceptable to BHEL.
 - ii) The Contractor fails to deposit the required Security deposit or commence the work within the period as per LOI/ Contract.
- EMD by the tenderer shall be withheld in case any action on the tenderer is envisaged under the provisions of extant “Guidelines on Suspension of business dealings with suppliers/ contractors” and forfeited/ released based on the action as determined under these guidelines.

6.0 SECURITY DEPOSIT

- 6.1 Upon acceptance of his tender bid, the successful tenderer must deposit Security Deposit within the time specified in the letter of intent. Security Deposit should be collected from the successful tenderer. The rate of Security Deposit will be as below:
The total amount of Security Deposit will be 5% of the contract value. EMD of the successful tenderer shall be converted and adjusted towards the required amount of Security Deposit
- 6.2 The successful tenderer on receipt of letter of intent can convey his acceptance in writing for conversion of EMD into security deposit.
- 6.3 If the work is awarded, the agency has to pay 50% of SD in advance on contract value before commencement of work after adjusting of EMD amount.
- 6.4 The balance amount to make up the required Security Deposit of 5% of the contract value may be accepted in the following forms:
 - i) Local cheques of Scheduled Banks (subject to realization) Demand Draft in favour of BHEL
 - ii) Bank Guarantee from Scheduled Banks/ Public Financial Institutions as defined in the Companies Act. The Bank Guarantee format should have the approval of BHEL
 - iii) Fixed Deposit Receipt issued by Scheduled Banks/ Public Financial Institutions as defined in the Companies Act (FDR should be in the name of the Contractor, a/c BHEL)
 - iv) Securities available from Indian Post offices such as National Savings Certificates, Kisan Vikas Patras etc. (held in the name of Contractor furnishing the security and duly endorsed/ hypothecated/ pledged, as applicable, in favour of BHEL)

(Note: BHEL will not be liable or responsible in any manner for the collection of interest or renewal of the documents or in any other matter connected therewith)
- 6.5 At least 50% of the required Security Deposit, including the EMD, should be collected before start of the work. Balance of the Security Deposit can be collected by deducting 10% of the gross amount progressively from each of the running bills of the Contractor till the total amount of the required Security Deposit is collected.
If the value of work done at any time exceeds the contract value, the amount of Security Deposit shall be correspondingly enhanced and the additional Security Deposit shall be immediately deposited by the Contractor or recovered from payment/s due to the Contractor.
- 6.6 Failure by the successful tenderer/bidder to deposit the security deposit amount as mentioned above within the stipulated time, which will include any extension that may be granted by the authorities, will render his earnest money deposit liable to forfeiture and his tender shall be consider as withdrawn. Security Deposit shall not be refundable to the contractor except in accordance with the terms of the contract.
- 6.7 The Security Deposit will be released along with the final bill or after completion of maintenance period for the work, whichever will be later, subject to the condition that nothing is outstanding against the Contractor.

7.0 STATUTORY REQUIREMENTS:

- 7.1 While quoting the rate, the tenderers are advised to take note of minimum wages prevailing at BHEL R.C.Puram which consists of State Basic +State DA and Additional payments payable to workmen.
- 7.2 The tenderer will be required to comply with all the statutory provisions such as Bonus, PF (12%), EDLI (0.5%), ESI, Gratuity, GST and other applicable taxes, BHEL Fair Wages prevailing at the time of payment or arrears thereof, declared Holidays, leave, T.S Labour Welfare Fund etc. The contractor shall submit the documentary evidence of payment on account of submission of statutory payments made to the concerned agencies every month and same may be submitted for clearance of bill.
- 7.3 The tenderer shall comply with the provisions of the Factories Act 1948, Contract Labour (Regulation and Abolition) Act 1970, ESI Act 1948, Employees Provident Fund and Miscellaneous Provisions Act 1952, Minimum Wages Act 1948, Payment of Gratuity Act 1972, Industrial Disputes Act, 1947, Payment of Bonus Act 1965, Employers Liability Act 1938, Inter State Migrants Workmen (Regulation of employment and conditions of Service) Act 1979 T.S Labour Welfare Fund Act, and or any other Laws and Rules that may be applicable from time to time to the workers engaged by him. The tenderer, when required by the Company shall produce the registers and records for verification and comply with other directions issued by the company for compliance of the statutory provisions.

- 7.4 The tenderer shall fully indemnify the loss if any caused to BHEL due to any default or non-observance of any of the laws, or any omission or commission or inability on the part of the Tenderer or his representative.
- 7.5 The tenderer shall, keep and produce for inspection at all times, forms, registers and other records required to be maintained under various statutes in order to enable scrutiny by the Company whenever required.
- 7.6 The tenderer shall produce to the Company, the documentary proof of payment of the said statutory dues. Non-observance of the provisions will be construed as default by the Tenderer in making such payment, and payment of his bill will be deferred despite other legal action.
- 7.7 The Income tax as applicable will be deducted from the bill of the contractor.
- 7.8 Each tenderer will be required to maintain the daily attendance of his labors in the prescribed Pro-forma for accounting payment of wages, deduction towards ESI & PF Contributions, payment of Bonus, leave etc.
- 7.9 The tenderer will have to follow the provisions of Payment of Bonus Act 1965 and Rules 1975, and is liable to pay Bonus to his workers as per HR-IR circular/instructions issued from time to time.
- 7.10 The tenderer will have to extend paid National Holidays and Festival Holidays to their workmen as per BHEL RC Puram direction or as per the provisions of the relevant Act and the Rules thereof. However, if due to exigencies of work the contractor engages his workmen on National Holidays or Festival Holidays contractor shall pay additional wages as prescribed under the provisions of the Act.

8.0 MANPOWER:

- 8.1 The Contractor shall provide the required manpower for executing the contracted work. The contractor shall not engage a person who is less than 18 years of age.
- 8.2 The contractor shall be responsible for safety of his workers while they are engaged for work connected with the contract. The Contractor shall be responsible for the appropriate usage of the Uniform and Shoe by their workmen.
- 8.3 The contractor, as the employer of his workmen, shall manage them. In the event of any dispute arising between the Tenderer and his employees, the Tenderer alone is solely responsible for resolving the dispute between them and BHEL will in no way be responsible for settling the dispute either statutory or otherwise.
- 8.4 The contractor will be solely responsible for executing the agreed work and the employees of BHEL will only oversee the proper execution of work. The contractor or his representatives shall be available in the factory to control and supervise his workers and take down instructions from the designated officials of BHEL. The cost of deployment of Supervisor has to be borne by the Contractor.
- 8.5 The contractor shall have full control over his workmen w.r.t determining service conditions, discharge, dismiss, or otherwise terminate their services at any time. The contractor shall be solely responsible for any claim arising out of employment or termination of employment of his employees and for statutory payments.
- 8.6 The contractor shall employ only such personnel who are medically fit. The company has right to direct the contractor to remove from the premises such of his personnel who may be physically, hygienically, clinically or medically unfit.
- 8.7 The contractor shall employ only such personnel who have not been found unfit for employment in Organizations such as Central/State/Public Undertakings by the Police authorities. Persons against whom criminal cases are pending or under investigation and persons found guilty of offences involving moral turpitude shall not be engaged for executing work.
- 8.8 The Contractor shall comply with all the operational rules and regulations, including safety and security rules framed by the company from time to time wherein the Contractor or his workmen happen to be operating / working. In the event of any of the workmen of the contractor violating any of the said rules and regulations, the Contractor would be required to remove forthwith such workmen from the company's premises.
- 8.9 Out of total manpower to be deployed the Contractor shall to the extent possible to deploy 15% scheduled castes and 7.5% of scheduled tribe community.

9.0 SAFETY:

- (i) Any casualty or damage caused to the property or person by any untoward incidents while executing this contract will be at the contractor's risk & cost.
- (ii) Violation of applicable safety, health & environment related norms, a penalty of Rs. 5,000.00(Rupees Five thousand) per occasion shall be imposed.
- (iii) Any compensation paid to victim shall be recovered from contractor, agency or firm, if the accident is attributable to negligence of Contractor, Agency or firm or any of its employees
 - a) Victim: Any person who suffers permanent disablement or dies in an accident as defined below:
 - b) Accident : Any death or permanent disability resulting solely and directly from any unintended and unforeseen injurious occurrence caused during the manufacturing/ operation and works incidental thereto at BHEL factories/offices and precincts thereof, project execution, erection and commissioning, services, repairs and maintenance, trouble shooting, serving, overhaul, renovation and retrofitting, trial operation,

performance guarantee testing undertaken by the company or during any works/during working at BHEL Units/Offices/townships and premises/project sites.

c) Compensation in respect of each of the victims:

(1) In the event of death or permanent disability resulting from Loss of both limbs: Rs. 10,00,000/- (Rs. Ten Lakhs)

(2) In the event of other permanent disability: Rs.7,00,000/- (Rs. Seven Lakhs).

d) Permanent Disablement: A disablement that is classified as a permanent total disablement under the proviso to Section 2 (I) of the Employee's Compensation Act, 1923.

10.0 PERIOD OF CONTRACT

i) The contract shall be for a period of 12 months from date of awardal. Hence the rates quoted by the bidder shall remain unchanged during the period of contract.

ii) The parties, if mutually agreed upon, may extend the period of contract for a further period of 12 months on the same terms and conditions.

If the contractor fails to execute the contract, BHEL reserves the right to execute the contract through any other contractors at the risk and cost of the contractor and the company reserve the right to take appropriate action against the defaulted contractor.

iii) BHEL is at liberty to terminate the Agreement by giving 30 days' notice in writing.

11.0 FAILURE TO COMPLY WITH CONTRACT

i) Notwithstanding anything contained in any other clause, BHEL reserves the right to terminate the contract due to any failure on the part of the Tenderer in discharging his obligations under the contract or in the event of his becoming insolvent or going into liquidation. The decision of the BHEL about the failure on the part of the Tenderer shall be final and binding on the tenderer.

ii) In case of any damage to the existing building, structures, materials, tools, furniture and fixtures, machines etc., caused from contractor's end directly or indirectly, the cost of its repairs or replacement will be recovered from the contractor. If there is any work stoppage in any area of the Plant due to the fault of the contractor, the contractor is liable to compensate the same.

iii) In the event of any failure on the part of the tenderer, BHEL shall have the right without prejudice to any other right or remedies, to get the work done through any other agency and the Tenderer shall be liable to compensate BHEL for any losses on this account. The additional cost, loss, if any incurred by BHEL will be recovered from the bills, security deposits, other dues, directly from the Tenderer or by initiating appropriate legal action.

12.0 PAYMENT TO THE CONTRACTOR

i. Normally, the periodicity of payment to the contractor shall be on a calendar month basis. The Contractor shall raise the bill for payment as per the contractual terms & conditions mentioned in the contract, which should be duly certified by the BHEL official in charge of the contracted work.

a) Payment shall be disbursed on the basis of actual unit executed, duly certified by the concerned executing agency in measurement book.

b) The Contractor shall record the executed work and get it certified by the concerned executing officials for processing the bills.

c) Before billing, the Contractor shall show the records of payment of wages to workmen, ESI & PF contribution to the relevant departments. Contractor shall show the proof of providing relevant Personnel Protective Equipment's to workmen. The claims/bills will be scrutinized, certified and process for payment by the respective user departments and forwarded to Accounts Department along with HR/IR clearance certificate for effecting payment.

d) Payment to the workers by Contractor to be made on or before 7th day of every month without fail, otherwise suitable action shall be taken at his (Contractor) risks and cost.

Following conditions shall be adhered strict during the contract period:

a. In case there is fall in the achieved output vis-à-vis desired output, contractor is to be warned in two spells.

b. If the unsatisfactory performance repeats, contract is liable to be short closed.

ii. The Contractor shall provide two pairs of stitched Uniform to each of his workmen as specified by BHEL. The Contractor is required to submit proof of expenditure incurred and acknowledgement from his workmen for providing stitched uniform. **If contractor fails to provide the said stitched uniform, Rs.1000/- will be deducted as penalty against each workmen engaged during the contract period. BHEL shall not reimburse any amount towards Uniform to the contractor. This uniform element is already considered in the estimate.**

- iii. The contractor shall pay bonus to all his workmen as per the applicable provisions of the payment of Bonus Act 1965 and its rules amendments from time to time for contract period. **The bonus element @ 8.33% is already considered in the estimate. BHEL shall not reimburse any amount towards this. The bonus amount payable shall be as per the BHEL Hyderabad HR circular.**
- iv. The contractor shall provide Personal Protective Equipment including one helmet, one pair per year safety shoe of standard specified by BHEL safety department and two pairs of socks to all his workmen during the contract period. The contractor is required to submit proof of expenditure incurred and acknowledgement from his workmen for providing Personal Protective Equipment. **If contractor fails to provide the said PPE, Rs.800/- will be deducted as penalty against each workmen engaged during the contract period. BHEL shall not reimburse any amount towards PPE to the contractor. This PPE's element is already considered in the estimate.**
- v. Any statutory increase in the labour wages during the period of execution shall be borne by the contractor.
- vi. The quoted rates should be applicable for additional quantity if any based on BHEL order receipts position and as well as for reduced quantity also.
- vii. The tenders which are finalized by Works & Services Contract cell are executed by different user departments. For such contracts, the execution and billing process for payment to the contractor will be carried out by respective user departments only.

13.0 SUB-CONTRACTING

The contractor shall not sub-contract or transfer or assign the contract in full or any part thereof to any other person or firm or company without written approval of Head of Indenting department.

14.0 LAWS GOVERNING THE CONTRACT

- i) The contract will be governed by the Laws of India for the time being in force and as amended or made from time to time.
- ii) All disputes shall be settled in accordance with the Laws of India for the time being in force and as amended from time to time.
- iii) All disputes arising out of or in relation to this contract or Agreement shall be settled by mutual discussions through Conciliation and in the event of failure of conciliation, such disputes shall be referred to Arbitration in accordance with the provisions of Arbitration and Conciliation Act, 1996.

15.0 LEGAL JURISDICTION:

In respect of all matters arising out of or pertaining to the contract, the cause of action there of shall be deemed to have arisen only at RC Puram, Hyderabad, where BHEL - HPEP / BHEL PE&SD is situated. All legal proceedings pertaining to the above matters or dispute shall be instituted only in courts having territorial jurisdiction over the place where BHEL-HPEP / BHEL PE&SD is situated and no other court shall have the jurisdiction.

16.0 DUTIES AND RESPONSIBILITIES OF THE CONTRACTOR:

- 16.1 The duties, responsibilities and obligations of the contractor including statutory responsibilities mentioned in this document are indicative and not exhaustive. Contractors are required to confirm with the concerned authorities for proper and complete compliance.
- 16.2 The contractor will abide by the provisions of Child Labour (Prohibition & Regulation) Rules 1988.
- 16.3 The following documents / forms under Contract Labour (Regulation & Abolition) Act 1970 and relevant rules therein shall be maintained by the contractor:
 - (i) A notice showing the wage period and date of disbursement of wages to be displayed at the place of work and a copy sent by the contractor to the HR Department (Rule 75).
 - (ii) A register of workmen Form XIII (Rule 75)
 - (iii) Employment card Form XIV (Rule 76)
 - (iv) Service Certificate Form XV (Rule 77)
 - (v) Muster Roll, Wage Register, Deductions Register, overtime Register Etc.
 - (vi) Half yearly return to be sent (In duplicate) by the contractor to the licensing officer. Form – XXIV (Rule 82 (I)) with a copy to HRM Department regularly.
 - (vii) All statutory registers and records shall be preserved in original for a period of Ten years and should be made available even after the contract is over for verification.
- 16.4 The contractor shall comply with the provisions of Contract Labour (R & A) Act 1970 including provisions relating to welfare and Health facilities as provided under the Contract Labour (R& A) Act 1970 and relevant rules.

- 16.5 All the Contractors shall submit the half yearly / yearly returns to Regional Labour Commissioner (Central), Hyderabad or appropriate authority as required under contract Labour (Regulation & Abolition) Act 1970 and forward a copy to HR Department.
- 16.6 BHEL, HPEP, RC PURAM – Hyderabad is a Notified Area under the provisions for ESI Act 1948. The contractor shall comply with the provisions of ESI Act, and will be responsible for any liability arising during the tenure of the work contract under the Act. The contractor should ensure ESI coverage and facilities to his workers (i.e. ESI code no. and ESI card etc.) as per ESI Scheme from ESI authorities including Medical Benefit etc.
The contractor shall arrange for filing of family declaration forms in respect of their contract labors and deposit the same in ESI office for issue of Identity card by ESI authorities. The contractor may deduct required ESI contribution from the wages of their employees as per law and deposit the same (Employees share) along with his contribution to the ESI authorities.
- 16.7 Workmen insured under ESI Act only shall be deployed in contract work. For the Persons not covered under the provisions of ESI Act, the contractor shall take required insurance under Employees Compensation Act 1923 with medical benefit.
- 16.8 The tenderer shall submit bi-annual return in Form 6 along with monthly Challans to the appropriate authority under the provisions of Employee's State Insurance Act 1948, under intimation to HR Dept.
- 16.9 Notwithstanding anything contrary to this, in the event of accident, the contractor shall be required to submit accident / injury report to the concerned authorities with a copy of the same to the designated BHEL Executive immediately and ensure the compliance of the ESI Act and rules made therein.
- 16.10 The tenderer shall submit the following returns to the appropriate authority under the provisions of Employee's Provident Fund and Misc. Provisions Act 1952, Employees' Pension Scheme 1995 under intimation to HR Dept.
- (i) Monthly return in Form 12 A along with form 5 & 10 (addition and deletion) and monthly Challan or any other form as modified by PF authorities
 - (ii) Annual Return in Form 6A along with Form 3A.
(till this procedure is discontinued by the PF authorities)
- 16.11 The Contractor shall maintain the following records as required under the Employees Provident Fund and Miscellaneous Provisions Act 1952, Employee's Pension Scheme 1995.
- o Declaration of Nomination, Form No.2 Para 33 and 61 (1).
 - o Attendance.
 - o Wage Register.
 - o Any other documents / registers as required
- 16.12 The contractor shall regularly on or before prescribed date of every month pay the amount of contribution (employer's contribution as well as the employee's contribution) as per the Employee's Provident Fund and Miscellaneous Provisions Act 1952, Employees' Pension Scheme 1995 and Employee's State Insurance Act 1948.
- (i) The contractor may recover from his workmen, the employee's contribution in accordance with the provisions of the said act and the Scheme but shall not recover the employer's contribution or the other charges from his employees in any manner.
 - (ii) The contractor shall submit along with monthly bills to BHEL, statement showing the recoveries of contributions in respect of employees employed by or through him along with the proof of Deposit of such contribution with the Concerned Authority and shall also furnish to BHEL such information, in the capacity of principal Employer, as required to be furnished under the provisions of the schemes under the Employees P.F. and Misc. Provisions Act 1952 and ESI Act, 1948 to the authorities under the said Acts.
 - (i) The Contractor shall arrange for his own P.F. and ESI Code Number from the PF and ESI authorities respectively. The expenditure incurred by the contractor towards payment of the Employers Contribution and PF Administrative charges is already included in the estimated price of BHEL.
- 16.13 **In case of revision of Wage/DA by appropriate Government or by BHEL after the award of work, any revision in Daily Wages Rate made by BHEL based on GO Notification, contractor will pay the difference of increase during the currency of the Contract. BHEL shall not pay the differential amount. Any failure to comply with the statutory requirements on the part of contractor shall disqualify such contractor from all contracts awarded to him and his name shall be black-listed for further tenders / contracts. In addition, the Contractor's security deposit shall be forfeited apart from consequential legal action against him**
- 16.14 The contractor shall maintain Form D as per Rule 5 of the Payment of Bonus Act, 1965 if applicable. The contractor is further liable to pay bonus to his employees in accordance with the payment of Bonus Act 1965 on completion of contract as per HR-IR circular/instructions issued from time to time and to keep all the records in Form C as per the said Act.

- 16.15 The contractor will be required to contribute towards gratuity payment of his employees (contract workers) required as per Payment of Gratuity Act. He will also be responsible to pay retrenchment compensation under the Act. In case of short closing of contract by either side, the Contractor shall settle all dues payable to workmen including Bonus on last working day.
- 16.16 In case the contractor employs women, he will discharge his obligation under law in respect of such women workers such as prohibition of engaging them during night hours, prohibition of employing them more than 9 hours per day, provision of crèche facility, grant of maternity leave as per rules etc.
- 16.17 The Wage period for the Workmen of Contractors engaged on long contracts shall be Calendar Month and the contractor shall be responsible for making payment of wages within 7 days of the closure of the wage month (on 07th day of the calendar month following the wage month) The disbursement shall be proposed to the 6th day, if the 7th day happens to be a holiday. The Contractor would be required to open an Account for Electronic Fund Transfer (EFT) of his Bills/Claims from BHEL as well as EFT of wages/OT/other payments of his workmen from his Bank Account to the Bank Accounts of his workmen so that risks associated with cash transactions can be avoided.
- 16.18 The Contractor shall be required to issue monthly Wage slips /OT Slips to their workmen. Further, the Contractors claims are to be accompanied by a Certificate from BHEL Official certifying that “the Wage /OT Slips for the previous month/current month have been issued by the contractor to all their workmen”. Further, the contractor would be required to issue Annual PF Statement from the PF Authorities for all his workmen engaged in BHEL HPEP, RC PURAM, HYD-32 before submitting Claim for refund of Security Deposit for the respective years.
- 16.19 In case contractor fails to make payment of wages to his employees or remittance of contribution to the concerned authorities, the Security deposit / other dues payable under the contract can be utilized by BHEL to discharge the liability of the contractor.
- 16.20 The workmen of the contractors shall wear uniform while attending duty in BHEL campus. The uniform shall be provided by Contractor to his workmen. The Contractor/his authorized representative shall ensure wearing of the Uniform by his workmen in the BHEL premises.
- 16.21 The liability for compensation on account of injury sustained by an employee of the contractor will be exclusively that of the contractor.
- 16.22 NATIONAL & FESTIVAL HOLIDAYS (as declared by BHEL): The contractor will give paid National Holidays and Festival Holidays to the workers as per Section 5 of National and Festival Holidays Act. However, if due to the exigency of work if any of his workmen is required to work on National Holiday or Festival Holiday, the contractor has to pay wages as per Section 5, sub section 2 and 3 of the said Act.
- 16.23 Besides the four national holidays i.e. 15th August, 26th January, 2nd October and 1st May (May day) if Govt. declares any other day as a national holiday same will be treated as paid holiday for the purpose of this contract. Accordingly, the contractor shall be required to provide paid holiday to its workers for the same. If any of the contract worker works on such additional declared national holiday, he will be entitled to additional wage for the said day.
- 16.24 In addition to the above holidays mentioned at Clause 4.23, in the event the Central / State Government declares any other holiday/s and if such Holiday/s is/are applicable to BHEL, RC Puram, Hyderabad also, then the tenderer/contractor shall extend paid Holiday/s to his workmen. The tenderer shall take into account all such occasions while quoting in the tender.
- 16.25 GENERAL ELECTIONS: If the general elections are held for State Assembly / Parliament and Government declares a public holiday for exercising the franchise, the contractor shall give their workmen half day leave in "First" shift only. The contractor's workmen working in “Second” and “Night” shifts will be required to exercise their franchise during their own time.
- 16.26 The Contractor shall maintain the following Documents, Registers, Forms as required under the FACTORIES Act 1948 and Rules 1950 thereof.
- (I) Leave Register Form No. 15
 - (II) Nomination Form No. 25
- 16.27 The contractor will extend leave with wage to his workers @ of one day for every 20 days work. To facilitate the proper execution of the Factories Act, these leaves shall be allowed during the same calendar year. The contractor will pay the un-availed portion of leave in cash along with monthly wages / at the end of Contract period.
- 16.28 Contractor has to ensure that all his workmen are granted one day weekly off after every 48 hrs. of working. The workmen working for more than 48 hours in any week shall be paid wages twice the ordinary rate of wage in accordance with the provisions of Section 59 of the Factories Act, 1948 read with the A.P Factories Rules 1950.
- 16.29 The contractor shall follow safety rules and regulations as per provisions of Factories Act 1948, and Rules at his own expense and arrange for the safety provisions as appended to these conditions or rules framed by the government from time to time.

- 16.29 A. **Refund of Security Deposit:** Security Deposit of contractor will be refunded only after the expiry of the contract period and based on the certification of successful completion of the contract and payment of PF, ESI and applicable statutory dues by the concerned Officials / department and submission of an Undertaking from the contractor, that in case of Claims from any of the statutory authorities, the same would be indemnified by the Contractor.
- 16.30 The Contractor shall be required to deposit GST as applicable to Central and State Tax Authority, Hyderabad before the stipulated date, if same is applicable as per rules in force from time to time. The amount so spent can be claimed from BHEL after submitting the proof of the same.
- 16.31 Contractor shall inform his PAN to BHEL. Income tax as applicable will be deducted at source by BHEL from the bills of contractor.
- 16.32 All the Registers and Records, forms, Notices maintained under the relevant Acts and Rules should be produced on demand before the Inspector or any other authority under the Act, failing which the contract may be terminated without any notice.
- 16.33 Contractor shall be required to submit a list of his workers to be deployed for the works contract giving details regarding Name of contract worker, Fathers Name, permanent and Present Address, Date of Birth, Qualification, Caste-SC/ST/OBC, ESI No, PF No. and the family details.
- 16.34 The contractor shall abide by all the labour legislations and other laws including the provisions of Contract Labour (Regulation & Abolition) Act, 1970, the Factories Act, 1948, the Payment of Wages Act, 1936, the Minimum Wages Act, 1948, ESI Act, 1948, Employee Provident Fund Act, 1952, AP Labour Welfare Fund Act, Payment of Bonus Act 1965, Payment of Gratuity Act 1972, and other relevant Acts applicable to his workmen under this Contract.
- 16.35 BHEL shall be indemnified against all losses, Claims, prosecutions etc. under any law.
- 16.36 The contractor shall promptly furnish all information and document required by BHEL authorities for the purpose of complying with the responsibilities of Occupier of the factory and shall render all the necessary assistance for the same.
- 16.37 The contractor will maintain proper discipline of his workmen and will ensure that his workers do not cause any loss or theft or damage to any company's property. The contractor will also be responsible for the good conduct of his workmen.
- 16.38 The contractor shall ensure and maintain uninterrupted progress of the work in accordance with instructions given to him on behalf of BHEL from time to time.
- 16.39 In case the contractor makes default in commencing the work within the time specified by BHEL without any reasonable cause, disputes any of the terms and conditions of the contract or refuses to execute the contract or any part thereof at any stage, the contract shall, without prejudice to any other right or remedies available to BHEL, be liable to be cancelled / terminated in part or in whole. In the event of such cancellation / termination of contract, the contractor shall be liable; to compensate BHEL for all losses incurred by BHEL including the loss suffered on account of having the work executed through any other contractor or department as may be convenient to BHEL, in accordance with the exigencies of the work. In case only a part of the contract is cancelled, the remaining portion of contract may be allowed be executed by the contractor.
- 16.40 The Contractor shall without fail give up-to-date information in writing of the attendance of the workers engaged by him. The Contractor will also submit the required documents and certificates as prescribed from time to time for the clearance and the payment of the Bill.
- 16.41 Whenever any sum of money is found to be recoverable from or payable by the contractor, the same will be deducted from any sum that may due or which at any time there after becomes due to the contractor under this contract or under any other contract or from his security deposit. In case the recoveries are not complete even after such deduction, the contractor shall pay the same or the balance thereof from the security deposit.
The contractor shall immediately thereafter pay such further sums as may be required to replenish the shortage caused by such recoveries in the amount of security deposit.
- 16.42 During the period of contract, if the contractor is awarded any other job work contract in BHEL, the contractor will have to inform the designated BHEL official before accepting the other work.
- 16.43 In case of failure on the part of the contractor to execute the work awarded to him within the stipulated time, the sum equivalent to the EMD as per BHEL Works Policy shall be forfeited as per the Undertaking provided by tenderers, after a week's notice issued by the awarding officer and BHEL may in its discretion award the contract to any other party.
- 16.44 In case of any extra work executed by the contractor, the contractor will be paid on pro-rata basis.
- 16.45 All the Terms and Conditions as mentioned in Work Order will also form a part of the Agreement.
- 16.46 BHEL shall have the right to deduct any sum from the bill of the contractor for making good the loss suffered by a worker or workers by reason of non-fulfillment of the conditions of the contract, Non-

payment of wages or of deduction made from his or their wages which are not justified by the terms of the contract or non-observance of the said contract Labour regulations.

- 16.47 The contractor shall be responsible for observance of local laws, employment of personnel, payment of taxes etc. As far as possible, workers shall be engaged from the local areas in which the work is being executed.
- 16.48 The contractor shall be wholly responsible for the behavior of the workmen at the work place and outside, in the BHEL premises.
- 16.49 The contractor shall be responsible for safe custody of BHEL's property like materials, tools etc., entrusted to him and if necessary arrange insurance at his own expense.
- 16.50 The contractor shall be responsible to make good and rectify at his own expense any defect, which may develop or may be noticed within the period of the contract.
- 16.51 BHEL shall be entitled to recover any payment made on behalf of the contractor under any law or otherwise.
- 16.52 BHEL Officer In-charge shall have the right to stop the work at any stage or at any time by giving the contractor seven days' notice in writing.

16.53 **ARBITRATION & CONCILIATION:**

Except as provided elsewhere in this Contract, in case amicable settlement is not reached between the Parties, in respect of any dispute or difference; arising out of the formation, breach, termination, validity or execution of the Contract; or, the respective rights and liabilities of the Parties; or, in relation to interpretation of any provision of the Contract; or, in any manner touching upon the Contract, then, either Party may, by a notice in writing to the other Party refer such dispute or difference to the sole arbitration of an arbitrator appointed by Head of the BHEL Unit issuing the Contract. The Arbitrator shall pass a reasoned award and the award of the Arbitrator shall be final and binding upon the Parties.

Subject as aforesaid, the provisions of Arbitration and Conciliation Act 1996 (India) or statutory modifications or re-enactments thereof and the rules made thereunder and for the time being in force shall apply to the arbitration proceedings under this clause, the seat of arbitration shall be at Hyderabad.

The cost of arbitration shall be borne as per the award of the Arbitrator. Subject to the arbitration in terms of Clause above, the Courts at Sangareddy, Telangana State shall have exclusive jurisdiction over any matter arising out of or in connection with this Contract.

Notwithstanding the existence or any dispute or differences and/or reference for the arbitration, the Contractor shall proceed with and continue without hindrance the performance of its obligations under this Contract with due diligence and expedition in a professional manner except where the Contract has been terminated by either Party in terms of this Contract.

In case of Contract with Public Sector Enterprise (PSE) or a Government Department, the following shall be applicable:

In the event of any dispute or difference relating to the interpretation and application of the provisions of the Contract, such dispute or difference shall be referred by either Party for arbitration to the sole arbitrator in the Department of Public Enterprises to be nominated by the Secretary to the Government of India in-charge of the Department of Public Enterprises. The Arbitration and Conciliation Act, 1996 shall not be applicable to arbitration under this clause. The award of the arbitrator shall be binding upon the Parties to the dispute, provided, however, any Party aggrieved by such award may make further reference for setting aside or revision of the award to the Law Secretary, Department of Legal Affairs, Ministry of Law and Justice, Government of India. Upon such reference the dispute shall be decided by the Law Secretary or the Special Secretary or Additional Secretary when so authorized by the Law Secretary, whose decision shall bind the Parties hereto finally and conclusively. The Parties to the dispute will share equally the cost of arbitration as intimated by the Arbitrator."

Conciliation clause:

The Parties agree that if at any time (whether before, during or after the arbitral or judicial proceedings), any Disputes (which term shall mean and include any dispute, difference, question or disagreement arising in connection with construction, meaning, operation, effect, interpretation or breach of the agreement, contract or the Memorandum of Understanding (delete whichever is inapplicable), which the Parties are unable to settle mutually), arise inter-se the Parties, the same may, be referred by either party to Conciliation to be conducted through Independent Experts Committee to be appointed by competent authority of BHEL from the BHEL Panel of Conciliators.

The proceedings of Conciliation shall broadly be governed by Part-III of the Arbitration and Conciliation Act 1996 or any statutory modification thereof.

17.0 Scope of work

Material Supply will be under BHEL Hyderabad-32 scope. (i.e.; Provision of wood and other packing consumables for making boxes)

Material will be provided to vendor as free issue for making packing cases, loading the items into boxes, primary packing for critical components etc.

Making of boxes shall be as per BHEL drawings (Refer Annexure-1, which is part of tender document

Scope of work involves the following activities

SL.NO	ACTIVITY
1	Making of plywood Enclosures
2	Marking of wood for cutting
3	Wood cutting
4	Assembly of cut pieces
5	Primary packing
6	Fixing GI Sheet
7	Moving of Empty Packing cases
8	Readiness of box for packing
9	Wrapping of small items with VCI paper etc
10	Loading of the items into the box
11	Arresting the material inside the box
12	Offering the material loaded boxes to QC
13	Closing of the box
14	Addressing
15	Fixing of L Clamps
16	Verification of material receiving from stores/shop
17	Modifications to Dept. Boxes
18	Moment of packing wood
19	Making of cardboard boxes
20	Shifting of packing boxes to respective CDCs
21	Filing of Gate passes/ICC/OBDs
22	Transport frames movement
23	Removing nails form wood
24	Marking/Labelling for export packing
25	Slings moment
26	Unloading of materials handed over by stores/shop
27	Saw dust cleaning at band-saw machines
28	Packing consumables moment from stores to respective shop
29	Helping in locating the packed items while loading onto the vehicles
30	OBDs handing over to Shipping Dept. every day
31	Packing Lists handing over to packing billing section
32	Bundling of pipes and structural
33	Fixing of metallic enclosures
34	Any other packing activity as instructed by packing in-charge

MEASUREMENT OF WORK AND PAYMENT THEREOF

1. A Measurement Book will be maintained in the BHEL by LOGISTICS Department located at 07 Annexe. The Contractor, wherein he or his authorized representative, will submit bill based on quantities completed and entries in the measurement book.
2. The Contract executing officer will inspect the work executed by the contractor and authenticate the entries made in the measurement book.
3. Short comings, if any, in the work executed will be pointed out by the designated employee to the Contractor or his authorized representative and the same will be rectified by him within two days to the satisfaction of the designated employee.
4. Payment towards work satisfactorily executed will be made to the Contractor at the following rates:

Measurement of work: Manufactured Packing boxes shall be billed against Schedule A of the rates quoted and Loading, packing & addressing of boxes shall be billed against Schedule B for any consignment for the generated packing list. The packing lists shall be certified by the respective section Packing-in-charges.

 - i) Payments will be made to the contractor once in a month after satisfactory completion of work on the basis of work carried out by him.
 - ii) All payments will be subject to deduction of income tax at source as per Income Tax Rules.
5. The total supervision & execution of the works is the sole responsibility of the contractor and he/she shall deploy adequate supervisors for the proposed work.
6. **Adequate work force to be deployed to meet the daily requirement. It is ascertained from the past experience that maximum deployment requisitioned will not exceed 25 USW & 26 SSW. Shift wise deployment will be decided on day-to-day basis in consultation with the contract executing officers within the above mentioned daily limit. Payment to contractor shall be made only on the basis of measurement of work.**

18.0 SPECIAL TERMS & CONDITIONS OF CONTRACT

1. In case of delay of payment of wages to the contract labour by the contractor, for more than a week, the contract executing officer will initiate action for payment of wages directly from BHEL side and recover the same from the payments due to the contractor along with penalty as decided by the respective product head. In case, the contractor default/fail to pay wages to the contract labour repeatedly (more than once) the contract executing officer shall take action for payment of wages directly by BHEL and contract may be short closed and initiate proceedings for blacklisting/banning the said contractor from participating in the future bidding/tendering in BHEL.
2. After awardal of the contract, the contractor shall open an office near BHEL, Hyderabad to have access for better communication and execution of the contract.
3. **Guidelines for payment of labours by contractor**

As per BHEL HR circular the daily wage rate is Exclusive of Holidays, Leave Wage, PF & ESI, PPE's and uniform.

Daily Wage rates as on date

 - U.S.W: Rs. 550.38 per day Inclusive of weekly off.
 - S.S.W: Rs. 587.73 per day Inclusive of weekly off
 - S.W: Rs. 623.54 per day Inclusive of weekly off
 - i) Leaves and Holidays
 - + 11 days paid holidays per year
 - + 18 days paid leaves per year.
 - ii) P F and E S I contributions wages

PF @ 13 % and ESI @ 3.25 % of basic wages should be contributed by the contractor on above daily wages.
 - iii) PPE's - Two Pairs Uniform per year along with stitching charges, Safety shoes with shocks, Helmet is to be provided to each workmen engaged during contract.
 - iv) Bonus to be paid as per the applicable provisions of the payment of Bonus Act 1965 and its rules amendments from time to time for contract period. The bonus amount payable shall be as per the BHEL Hyderabad HR circular.
 - v) Other PPE's like hand gloves, goggles, masks etc. if required during execution of work needs to be provided by the contractor.
4. Over Run Compensation not applicable.

19.0 EVALUATION OF PRICE BID:

- i. A single percentage (%) must be quoted for all categories mentioned in the price bid Proforma as the job would be awarded to one or more successful tenderer as per NIT criteria.
- ii. Evaluation of the L-1 offer shall be computed on overall lowest cost to BHEL basis. (Grand Total Price for all the items (price bid) indicated above minus tax credit, if, any)
- c) In the event of two or more tenderers becoming L1, the selection of the tenderer for the purpose of awarding contract will be on the basis of LOTTERY to be held in presence of representatives of L1 tenderers.
- d) Contractor shall take total care to educate himself to know the prevailing wages payable to contract labour in BHEL RC puram and quote rates taking into account all aspects of contract

20.0 Terms and conditions of Contract Agreement

1. Refund of Security Deposit: Security Deposit of contractor will be refunded only after the expiry of the contract period and based on the certification of successful completion of the contract and payment of PF, ESI and applicable statutory dues by the concerned Officials / department and submission of an Undertaking from the contractor, that in case of Claims from any of the statutory authorities, the same would be indemnified by the Contractor.
2. The contractors would be required to submit their Claims/bills along with the proof of payment of wages, PF, ESI etc., to the respective user departments. The claims/bills will be scrutinized, certified and process for payment by the respective user department and forward to Accounts Department along with HR/IR clearance certificate for effecting payment.
3.
 - a) The Contractor shall provide two pairs of stitched Uniform to each of his workmen and catering cap as specified by BHEL. The Contractor is required to submit proof of expenditure incurred and acknowledgement from his workmen for providing stitched uniform. If contractor fails to provide the said stitched uniform, Rs.1000/- will be deducted as penalty against each workmen engaged during the contract period. BHEL shall not re-imburse any amount towards Uniform to the contractor.
 - b) The contractor shall provide Personal Protective Equipment including one helmet, one pair per year safety shoe of standard specified by BHEL safety department and two pairs of socks to all his workmen during the contract period. The contractor is required to submit proof of expenditure incurred and acknowledgement from his workmen for providing Personal Protective Equipment. If contractor fails to provide the said PPE, Rs.800/- will be deducted as penalty against each workmen engaged during the contract period. BHEL shall not re-imburse any amount towards PPE to the contractor.
4. The contractor shall pay bonus to all his workmen as per the applicable provisions of the payment of Bonus Act 1965 and its rules amendments from time to time for contract period. BHEL shall not reimburse any amount towards this and the bonus amount payable shall be as per the BHEL Hyd HR circular.
5. The contractor shall fully comply with the following enactments / guidelines:
 - (a) Contract Labour (R & A) Act, 1970 & applicable Rules thereof
 - (b) Minimum Wages Act 1948 (Wage Rates not less than that notified by State Labour Department / notified by BHEL, RC Puram (whichever is higher) from time to time)
 - (c) Payment of Wages Act, 1936
 - (d) ESI Act, 1948
 - (e) EPF & Misc. Prov. Act, 1952
 - (f) Employees Compensation Act, 1923.
 - (g) A.P Labour Welfare Fund Act, 1987
 - (h) Inter State Migrant Workmen (RE & CS) Act, 1979
 - (i) Payment of Bonus Act, 1965
 - (j) Payment of Gratuity Act, 1972
 - (k) Equal Remuneration Act, 1976
 - (l) The Company's instructions as issued from time to time in regard to working hours, wages, leave, holidays etc.
6.
 - a. The contractor shall obtain License from the Competent Authority if he engages 20 (twenty) or more workmen in BHEL RC Puram under Contract Labour (Regulation and Abolition) Act, 1970. The Contractor shall submit a valid Contract Labour License to BHEL, RC Puram, on or before the date of commencement of contract.
 - b. The contractor shall obtain License from the Competent Authority if he engages 5 (five) or more workmen under Inter State Migrant Workmen (RE & CS) Act, 1979 in case the contractor engages workmen recruited from outside State of Telangana in which BHEL RC Puram located. The Contractor shall submit a valid Contract Labour License to BHEL, RC Puram, on or before the date of commencement of contract.

7. The Contractor shall produce the following Registers and forms (as applicable) before commencement of work, for verification by the Contract Executing Officer / Contract Labour Cell of the company, without which labour entry permission will not be granted.
- (a) Form XIII - Register of workmen employed by contractor (Rule 75)
 - (b) Form XIV - Employment card issued by contractor (Rule 76)
 - (c) Form XVI - Muster Roll (Rule 78(1)(a)(i))
 - (d) Form XVII - Register of wages (Rule 78(1)(a)(i))
 - (e) Form XVIII - Register of wages-cum Muster Roll (in case of weekly payment)
 - (f) Form XIX - Wage Slip (Rule 78) (b)
 - (g) Form XX - Register of deduction for damages or loss (Rule 78) (1)(a)(ii)
 - (h) Form XXI - Register of files (Rule 78) (1)(a)(ii)
 - (i) Form XXII - Register of advances (Rule 78) (1)(a)(ii)
 - (j) Form XXIII - Register of overtime (Rule 78) (1)(a)(iii)
 - (k) Form XXIV - Return to be sent by the contractor to licencing Officer (Rule 82) (1)

The contractor shall maintain the above and any other registers and forms applicable under various Acts/Rules neatly, completely and legibly for inspection by various statutory authorities and by the company officials even at short notice. All above registers shall be maintained at the place of work.

In addition to the above the following are required to be taken care by the contractor under Contract Labour (R&A) Act 1970

- a. Copy of licence to be displayed at the workspot as required under Rule 25 (2) 9 (ix)
 - b. Rates of wages, hours of work, wage period, date of payment, name and address of inspector, date of payment of unpaid wage in English, Hindi and Telugu are to be displayed as per rule 81 (1) (i)
 - c. Notice showing wage period, place and date of disbursement of wages has to be displayed and a copy of the same is required to be sent to Principal Employer under acknowledgement as per rule 71
 - d. An abstract of the Act and Rules in the form approved by the Chief Labour Commissioner (Central), New Delhi to be displayed in English and Hindi and Telugu as per rule 79.
 - e. Copies of Notices required to be displayed as per Rule 81(1) (i) and any change occur the same shall be submitted as per Rule 81 (2).
 - f. Notice of commencement of work has to be given as required under Rule 25 (2) (viii) in form VIA
 - g. Register of person employed to be maintained as required under Rule 75
 - h. Employment cards were to be issued as per rule 76 (i)
 - i. Register of wages and muster roll to be maintained as per Rule 78(1)(a)(i)
 - j. Register of fines, deductions and advances to be maintained as per Rule 78(1)(a)(ii)
 - k. Register of overtime to be maintained as per rule 78(1)(a)(iii)
 - l. Wage slips have to be issued as per rule 78(1)(b)
 - m. Half Yearly return for the half year ending _____ to be submitted as per Rule 82(1) to the Licensing Officer
 - n. Latrines and Urinals to be provided for the use of the workers as per rule 51 to 56 read with section 18
 - o. First aid facilities to be provided for the use of the workers as per rule 58 read with section 19
 - p. Creche facilities to be provided for the use of children of women as per Rule 25(2)(vi)
8. The contractor shall observe
- (a) Weekly rest day
 - (b) The Company List of Holidays.
9. Contractor shall obtain complete bio-data of the labour, employment certificate and Antecedent verification (issued by Local Police Dept.,) in the prescribed form for each labour and supervisor engaged by him, and shall submit the same to the Human Resource Department/IR section through the contract executing officers before commencement of the work.
10. The entry permits are to be issued to the Contract Labour by Assistant Commandant / Plant (CISF), based on the requisition submitted by Contract Executing Officer and forwarded by Executive in charge of Contract Labour Cell of HR IR section
11. Every contractor shall submit a notice regarding commencement and completion of work in Form-VI A&B [Rule 25(viii) & 81(3)] to Contract Labour Cell of HR IR section through his contract executing officer, for forwarding the same to State / Central Labour Department as applicable
12. The contractor shall make himself or his representative available at the work spot every day during execution of work, for effective supervision. The Contractor or his supervisor shall submit list of shift wise contract labour engaged by him in duplicate to CISF Personnel at J Gate on daily basis.
13. The Contractors shall pay to their workmen applicable minimum wages prevailing at BHEL R.C.Puram which consists of State Basic +State DA and Additional payments.

14. The Contractor shall comply with all the statutory provisions such as Bonus, PF (12%), EDLI (0.5%), ESI, Gratuity, GST, BHEL Fair Wages prevailing at the time of payment or arrears thereof, declared Holidays, leave, AP Labour Welfare Fund etc. The contractor shall submit the documentary evidence of payment on account of submission of statutory payments made to the concerned agencies every month and same may be submitted for clearance of bill.
15. The contractor shall attend to all inspections notified/conducted by the personnel department, Labour department, P.F. authorities, Factory Inspectors, ESI inspectors or any other such authorities under the Act, failing which appropriate action shall be initiated.
16. Non-compliance of provisions under any Acts/Rule/instructions/guidelines shall make the contractor liable for penal action including termination of contract.
17. Contractor shall furnish in a separate letter, his place of residence and postal address. The delivery at the above named place or posting in a Post Box regularly maintained by the Postal Department or sending letters registered for acknowledgement of any notice, letter or other communication to the contractor shall be deemed sufficient service thereof upon the contractor. Change in address shall come into force at any time by an instrument executed by the contractor and delivered to the Company official who has signed the contract.
18. The contractor must satisfy himself by personal study and examination of the specifications furnished and understand thoroughly the scope of proposed work in detail and all conditions affecting the work before entering into the contract. There shall not be at any time, dispute/complaint of any nature regarding scope of work and interpretation of specifications or any misunderstanding with regard to nature or omission of the work to be done nor shall any application for compensation in terms of time and money shall be accepted by Company regarding the above.
19. Contractor shall in his absence keep competent agent/Supervisor constantly on the works and any directions or explanations given by the "Contract Signing Officer" or his representative to such agent/supervisor shall be held to have been given to the contractor himself.
20. Contractor on the advice of the Company official shall immediately remove any person/s employed by him, who may in the opinion of the Company official is incompetent or misconducts himself and such persons shall not be again employed on the works without written permission of the Company official.
21. Wherever required, the contractor shall erect and maintain at his own cost temporary weather proof sheds at such places approved by the Company for keeping materials under cover.
22. The contractor shall give all notices required by the Acts, Regulation, Bye-laws, and pay all fees in connection therewith unless and otherwise arranged and decided in writing with the Company. He shall also ensure that no attachments are made against materials or work forming part of or for the use of the contractor.
In all such cases, contractor shall protect and indemnify the Company against any claim or liability arising from or based on the violation of any such laws, ordinances, regulations, orders, decrees or attachment either by himself or by his employees.
23. It shall be contractor's sole responsibility to protect the public and his employees against accident from any cause and provide required safety equipment's and shall indemnify the Company against any claims for damages for injury to the person or property resulting from any such accidents and shall, where the provisions of the Employees Compensation Act do not apply, take steps to properly insure against any claims thereunder.
24. In the event of any accident in respect of which compensation may become payable under the Employees Compensation Act. VIII of 1923 whether by the contractor or by the Company as principal, it shall be lawful for the Company to retain out of monies due and payable to the contractor such sum or sums of money as may, in the opinion of the Company shall be final in regard to all matter arising in this clause.
25. No work shall be done on Sundays or on other declared Holidays of the Company without the written permission of the Company officer in charge of the work and HR/IR section of Contract Labour Cell. The contractor shall comply with the provisions of the Factories Act 1948 if the same are applicable.
26. The contractor shall keep his work place clean and safe to avoid injuries to men and damage to finished products / equipment.
27. On the occurrence of an accident, which results in the death of any of the workmen employed by the contractor or which is so serious as to be likely to result in the death of any such workmen, the contractor shall within 24 hours of the happening of such an accident intimate in writing to the Company official in charge of the work. The Contractor will also pay compensation as determined by the Authorities.
28. The contractor shall indemnify the Company against all losses or damages sustained by the Company resulting directly or indirectly from his failure to give intimation in the manner aforesaid including the penalties or dues if any and become payable by the Company, as a consequence of failure, the Company to give notice under the Employees Compensation Act 1923 or otherwise confirm to the provisions of the said Act in regard to such accident.

29. The contractor shall ensure adherence to all statutory requirements applicable to BHEL.
30. The contractor shall ensure abidance by all the labour laws especially including Contract Labour (R&A) Act 1970, Payment of wages Act 1936, Employees Compensation Act 1923, Factories Act, 1948, Minimum Wages Act 1948, Payment of Bonus Act 1965, Payment of Gratuity Act 1972, ESI Act 1948 and Provident Fund Misc. Prov. Act 1952 etc., as amended from time to time.
31. The contractor shall fully indemnify the loss if any caused to BHEL due to any default or non-observance of any of the laws, or any omission or commission or inability on the part of the contractor or his representative.
32. The contractor shall, keep and produce for inspection at all times, forms, registers and other records required to be maintained under various statutes in order to enable scrutiny by the Company whenever required.
33. The contractor shall produce to the Company, the documentary proof of payment of the said statutory dues. Non-observance of the provisions will be construed as default by the contractor in making such payment, and payment of his bill will be deferred despite other legal action.
34. The Income tax as applicable will be deducted from the bill of the contractor.
35. Each Contractor shall maintain the daily attendance of his labours in the prescribed Pro-forma for accounting payment of wages, deduction towards ESI & PF Contributions, payment of Bonus, leave etc.
36. The contractor will have to extend paid National Holidays and Festival Holidays to their workmen as per BHEL RC Puram direction or as per the provisions of the relevant Act and the Rules thereof. However, if due to exigencies of work the contractor engages his workmen on National Holidays or Festival Holidays contractor shall pay additional wages as prescribed under the provisions of the Act.
37. In addition to the above holidays mentioned at Clause 38, in the event the Central / State Government declares any other holiday/s and if such Holiday/s is/are applicable to BHEL, RC Puram, Hyderabad also, then the Contractor shall extend paid Holiday/s to his workmen.
38. The contractor shall obtain a separate Provident Fund Code for his establishment and ensure implementation of Provident Fund & Misc. Prov. Act 1952 in the case of all eligible Labours engaged by him in the BHEL RC Puram (employees) and in the process shall conform to all stipulated conditions under the Provident Fund & Misc. Provisions Act 1952 and rules framed thereunder. The PF contribution i.e. 12% shall be paid on total wages paid to the contract labour.
39. Notwithstanding the above clause, in case of any financial loss incurred by company on account of contravention of the Provident Fund regulations or any regulations of rule by the contractor, the contractor shall submit an undertaking to indemnify the company to the extent of the loss incurred by the company.
40. The contractor should engage only those labours who shall be more than 18 (eighteen) years of age.
41. The contractor shall not resort to subcontracting under any circumstances without written consent from BHEL
42. The contractor shall provide the required safety equipment to the labours engaged by him.
43. Contractor shall issue "Employment Card" to all labour and supervisors covered under the labour / works / job work contract as prescribed under the Contract Labour (R&A) Acts/Rules.
44. A copy of the agreement between contractor and his labour shall be submitted to the Contract Labour Cell of HR-IR section
45. Whenever the term "CONTRACTOR" is used, it shall be understood to refer to the particular person, firm or corporation with whom an agreement has been made by the concerned Company official for executing the work defined in the concerned agreement and for the purpose of instructions regarding compliance with contract conditions, it shall include the contractor's authorised agents, who are entrusted with the work by contractor.
46. The Company does not expressly or by implication agree that the actual amount of the work to be done at BHEL shall correspond there with, but reserves the right to increase or decrease the quantity of operations / unit / number of persons deployed etc., or portion of the work as he deems necessary.
47. All the works shall be carried out in accordance with the directions and to the satisfaction of the Company official in accordance with the drawings, specifications and instructions. Supplementing or explaining the same as may be from time to time shall be done by the Company official.
48. For all modifications, omissions or additions to the specifications, the Company shall issue revised written instructions and no modifications, omission or addition shall be made unless so authorized and directed by the Company in writing.
49. The Company shall have the privilege of ordering modifications, omissions, or additions at any time before completion of the work.
50. The contractor shall be solely responsible for executing the agreed work and the employees of BHEL will only oversee the proper execution of work. The contractor or his representatives shall be available in the factory to control and supervise his workers and take down instructions from the designated officials of BHEL. The cost of deployment of Supervisor has to be borne by the Contractor. Contractor to ensure

payment of minimum wages as prescribed from time to time to the said Supervisors and also ensure statutory payments such as PF, ESI and bonus as per HR-IR circular/instructions issued from time to time.

51. The contractor shall have full control over his workmen w.r.t determining service conditions, discharge, dismissal, or otherwise terminate their services at any time. The contractor shall be solely responsible for any claim arising out of employment or termination of employment of his employees and for statutory payments.
52. The contractor shall employ only such personnel who are medically fit. The company has right to direct the contractor to remove from the premises such of his personnel who may be physically, hygienically, clinically or medically unfit.

21.0 Special Instructions:

1. If the tender is made by an individual, it shall be signed with his full name and his address shall be furnished. If it is made by firm, it shall be signed with the co-partnership name by a member of the firm, who shall also sign his own name, also furnish the name and address of each member of the firm. If the tender is made by a corporation, it shall be signed by a duly authorised Officer who shall produce with the tender, satisfactory evidence of his authorisation. Such tendering corporation/firm is required to furnish evidence of its existence along with bid.
2. The EMD will be refunded to the unsuccessful Tenderers on application after rejection of the tender is intimated. The earnest money will be retained in the case of the successful tenderers and either of the cases will not carry any interest. It will be dealt with as provided in the conditions attached to the tender.
3. Whenever a tender is to be accepted, the tenderer, whose tender is under consideration, shall attend the Office of " Officer Inviting the Tender " on the date fixed by written intimation to him. He shall forthwith, upon intimation being given to him by the "Officer Inviting the Tender" (Ex. DGM (WSC)) for acceptance of his tender, complete the execution of the agreement by signing all documents connected therewith. Failure to do so and not to commence the work within one month from the date of intimation, shall entail forfeiture of the earnest money.
4. Tenderers shall peruse carefully the instructions and directions to the parties given in the tender document and the conditions there of and all other relevant documents before quoting the rates for the work. The approximate quantity of work to be executed under each class is given in the schedule. The quantities are given with a view to enable tenderer to quote his overall rate for each class of work in the tender form and for a uniform comparison of tenders. It shall be definitely understood that the schedule is liable to alterations at the discretion of accepting authority.
5. Tenderers shall keep the offer valid for a period of 120 days from the date of opening of tender. After submitting the tender, he will not recall his offer or modify the terms and conditions thereof. Should the tenderer fail to observe or comply with the foregoing stipulations, the EMD shall be forfeited.
6. Tenderers have to quote their rates in the tender schedule legibly written in figures and words and those not submitted in proper form are liable for rejection.
7. The submission of tender shall be strictly in accordance with the terms and conditions stipulated in this tender notice. No counter conditions will be acceptable or valid.
8. The tenderers must satisfy themselves by personal study and examination of the drawings/specifications furnished and understand thoroughly the scope of proposed work in detail and all conditions affecting the work before quoting. There shall not be at any time after submission of the tender, dispute/complaint of any nature regarding the scope of work and interpretation of specifications or any misunderstanding with regard to nature or omission of the work to be done nor shall any application for compensation in terms of time and money shall be accepted by BHEL in regard to the above.
9. Contractor shall be deemed to have included in his tender price of all the plant, machinery and appliances required for the purpose of all operations connected with the work embraced under the contract to secure a satisfactory quality of work and rate of progress which in the opinion of the " Contract Signing Officer" will ensure the completion of the work within the time specified.
10. The contractor has to produce the bank guarantee, in the prescribed proforma valid for the contract period for a value calculated at the rates mentioned, towards security deposit. The claim period under the guarantee shall be valid for six months after expiry of the contract.
11. **Over and above the agreed payments payable by the Contractor to the Contract Labours, if any declared by BHEL, shall be borne by BHEL.**
12. This is a time bound contract for period mentioned, and does not envisage any extension of time / period unless otherwise it is given in writing.
13. Any statutory increase in the labour wages during the period of execution shall be borne by the contractor.
14. The quoted rates should be applicable for additional quantity if any based on BHEL order receipts position and as well as for reduced quantity also.

21.1 Specific information communicated to vendors

Apart from the fulfilment of general conditions, the vendors who wish to submit the bids for the above category have to know the following specific information

1. Payment will be disbursed on the basis of actual work executed duly certified by executing agency of concerned shop in measurement book.
2. All the materials brought inside are to be entered at CISF gates and supplied to site by contractor for using in works.
3. The contractor should follow all the safety precautions while executing the work.
4. The contractor shall ensure deployment of adequate machines and man power as required for the work and suggested by Engineer-in-charge.
5. The quantities are shown above are approximate and liable for variation. The quoted rates should be applicable for additional quantity if any based on BHEL order receipts position and as well as for reduced quantity also. The Contractor is bound to execute the work in the period of contract on the same terms and conditions without any demur.
6. All BHEL General Conditions of the Contract shall be applicable.
7. **The agency should affix his signature at the end of each page of the document and enclosed supporting documents (by bidder) also with Rubber Seal.**
8. The contractor or his authorized representative shall be always present at the work site.
9. The contractor shall submit the daily progress report of the works carried to the Engineer-in-charge.
10. The contractor shall be responsible for observance of local laws, employment of personnel, payment of taxes etc. As far as possible, workers shall be engaged from the local areas in which the work is being executed.
11. The contractor shall submit prices as per price bid proforma enclosed and shall follow strictly NIT conditions.
12. Bid should be free from correction, overwriting, using corrective fluid, etc. Any interlineation, cutting, erasure or overwriting shall be valid only if they are attested under full signature(s) of person(s) signing the bid else bid shall be liable for rejection.

22.0 MSE Supplier

MSE suppliers can avail the intended benefits (Tender documents fee of cost, exemption of EMD) only if they submit along with the offer, attested copies of either EM II certificate having deemed validity (five years from the date of issue of acknowledgement in EM II) or valid NSIC certificate or EM II certificate along with attested copy of a CA certificate (Format enclosed at Annexure-2 where deemed validity of EM II certificate of five years has expired) applicable for the relevant financial year (latest audited). Date to be reckoned for determining the deemed validity will be the date of bid opening (Part 1 in case of two part bid). Non submission of such documents will lead to consideration of their bid at par with other bidders. No benefit shall be applicable for this enquiry if any deficiency in the above required documents are not submitted before price bid opening. If the tender is to be submitted through e- procurement portal, then the above required documents are to be uploaded on the portal. Documents should be notarized or attested by a Gazetted officer.

Annexure-I**Certificate by Chartered Accountant on letter head**

This is to Certify that M/s.....
 (hereinafter referred to as 'company') having its registered office at is
 registered under MSMED Act 2006, (Entrepreneur Memorandum No (Part-II)
dtd:.....Category:
 (Micro/Small).

Further verified from the Books of Accounts that the investment of the company as on date as
 per MSMED Act 2006 is as follows:

1. **For manufacturing Enterprises:** Investment in plant and machinery (i.e. original cost excluding land and building and the items specified by the Ministry of Small Scale industries via its notification No. S.O. 1722 (E) dated October 5, 2006 :)
 Rs.Lacs
2. **For Service Enterprises:** Investment in equipment (original cost excluding land and building and furniture fittings and other items not directly related to the service rendered or as may be notified under the MSMED Act.2006.)
 Rs..... Lacs

The above investment of Rs..... Lacs is within permissible limit of
 Rs..... Lacs for Micro/ Small (strike off which is not applicable)
 Category under MSMED Act 2006.

Date:

(Signature)

Name:

Membership number:

Seal of Chartered Accountant

Penalty for Packing activity

Contractor has to start the packing activity immediately after the information received from the system/by CDC official. Duration allowed generally should be as below. Any delay in packing activity shall attract penalty as given below. Penalty for delay in packing shall not be applicable if reasons for such delay are attributable to BHEL. For 1 day delay in packing, Penalty shall be 5% of packing charges of non-packed OBDs/Boxes. If delay is more than 1 day, penalty shall be 5% + 1% of packing charges of non-packed OBDs for each day delay limited to a maximum of 50% of packing charges of individual non-Packed OBDs. Example : If 2 OBDs having packing charges of Rs.10000 are packed with 4 days delay, then 5% for 1st day+3% for remaining 3days i.e;8% penalty shall be levied which is Rs.800.

SNO	ITEM DESCRIPTION	PACKING SCHEDULE	MAX. BOXES/OBDS TO BE PACKED(NO.S)	MIN. DURATION (DAYS)	EMAIL DT	PACKING COMPLETION DATE	DELAY IN PACKING (DAYS)	PACKING DELAYED OBD NO.S	CDC	SUPERVISOR NAME	REASON FOR DELAY
1	ITEMS FALLING UNDER PACKING SCHEDULES 1,2,4,5,11,15,17	1,2,4,5,11,15,17,29	8	2							ATTRIBUTABLE TO BHEL/DELAY BY CONTRACTOR
2	ITEMS FALLING UNDER PACKING SCHEDULES 3,6,7,8,9,18,19	3,6,7,8,9,18,19, 23 & 27	4	2							
3	ITEMS FALLING UNDER PACKING SCHEDULES 13,16,22	13,16,22 & 24	1	2							
4	ITEMS FALLING UNDER PACKING SCHEDULES 10,14,20,21	10,14,20,21, 25, 26 & 28	10	2							
5	ITEMS FALLING UNDER PACKING SCHEDULE 12	12	4	2							

FOR SNO.1 ABOVE,IF NO. OF BOXES TO BE PACKED LIE BETWEEN 1-8,MIN. DURATION OF 2 DAYS SHOULD BE GIVEN.IF NO. OF BOXES TO BE PACKED ARE MORE THAN 8,THEN DURATION SHOULD BE INCREASED BY 1 DAY FOR EVERY 4 BOXES OR PART THERE OF.EAMPLE: IF 9-12 BOXES ARE TO BE PACKED,MIN.DURATION SHOULD BE 3 DAYS.

FOR SNO.2 ABOVE,IF NO. OF BOXES TO BE PACKED LIE BETWEEN 1-4,MIN. DURATION OF 2 DAYS SHOULD BE GIVEN.IF NO. OF BOXES TO BE PACKED ARE MORE THAN 4,THEN DURATION SHOULD BE INCREASED BY 1 DAY FOR EVERY 2 BOXES OR PART THERE OF.EAMPLE: IF 5-6 BOXES ARE TO BE PACKED,MIN.DURATION SHOULD BE 3 DAYS.

FOR SNO.3 ABOVE,GENERALLY PACKING ACTIVITY INVOLVES PRIMARY PACKING OF THE COMPONENT(SNO.5) AND THEN MAKING OF PLYWOOD ENCLOSURE.HENCE,MIN.DURATION FOR PACKING EACH ITEM SHOULD BE 2 DAYS.

FOR SNO.4 ABOVE,IF NO. OF OBDS TO BE PACKED LIE BETWEEN 1-10,MIN. DURATION OF 2 DAYS SHOULD BE GIVEN.IF NO. OF OBDS TO BE PACKED ARE MORE THAN 10,THEN DURATION SHOULD BE INCREASED BY 1 DAY FOR EVERY 5 OBDS OR PART THERE OF.EAMPLE: IF 11-15 OBDS ARE TO BE PACKED,MIN.DURATION SHOULD BE 3 DAYS.

FOR SNO.5 ABOVE,IF NO. OF OBDS TO BE PACKED LIE BETWEEN 1-4,MIN. DURATION OF 2 DAYS SHOULD BE GIVEN.IF NO. OF OBDS TO BE PACKED ARE MORE THAN 4,THEN DURATION SHOULD BE INCREASED BY 1 DAY FOR EVERY 2 OBDS OR PART THERE OF.EAMPLE: IF 5-6 OBDS ARE TO BE PACKED,MIN.DURATION SHOULD BE 3 DAYS.

IF ANY ITEM FALLING UNDER PACKING SCHEDULES OF SNO.1,2,AND 4 MENTIONED ABOVE ALSO REQUIRES PACKING SCHEDULE 12 MENTIONED IN SNO.5,THEN MIN.DURATION SHOULD BE SUM OF DURATIONS OF SNO.1+5 OR SNO.2+5 OR SNO.4+5 AS THE CASE MAY BE .EXAMPLE:IF 4 BOXES OF SNO.2 MENTIONED ABOVE ALSO REQUIRE PACKING SCHEDULE 12 OF SNO.5,THEN MIN. DURATION SHOULD BE 4 DAYS.

PACKING SUPERVISOR OF RESPECTIVE CDC GIVES AN EMAIL TO CPDC PACKING EXECUTIVE REGARDING OBDS TO BE PACKED IN THE ABOVE TABLE FORMAT.THEN CPDC EXECUTIVE CONSOLIDATES THE PACKING REQUIREMENTS OF ALL CDCS AND SEGREGATES THEM INTO 5 LINE ITEMS MENTIONED IN THE TABLE AND DECIDES DURATION FOR PACKING.THE SAME WILL BE COMMUNICATED TO CONTRACTOR AND PACKING SUPERVISORS BY EMAIL.ONCE PACKING ACTIVITY IS COMPLETED,EACH SUPERVISOR OF RESPECTIVE CDC SHOULD FILL THE ABOVE TABLE AND SEND IT TO CPDC EXECUTIVE ONCE IN A MONTH FOR CALCULATING PENALTY FOR DELAY IN PACKING ACTIVITY.

NOTE : 1.ALL 5 LINE ITEMS MENTIONED ABOVE SHALL RUN CONCURRENTLY.

2.CONTRACTOR HAS TO ABIDE BY THE SOP RECOMMENDED BY CDC OFFICIAL FROM TIME TO TIME.

3.FOR ANY DEFAULT TO IT,HE SHALL BE PENALIZED BY RS.5000/DAY OF CONTINUATION OF DEFAULT.

4.ALL PENALTIES PUT TOGETHER FOR THE ENTIRE CONTRACTUAL PERIOD SHALL NOT EXCEED 15% OF TOTAL CONTRACT VALUE IRRESPECTIVE OF THE EXECUTED PART.

BHEL drawings

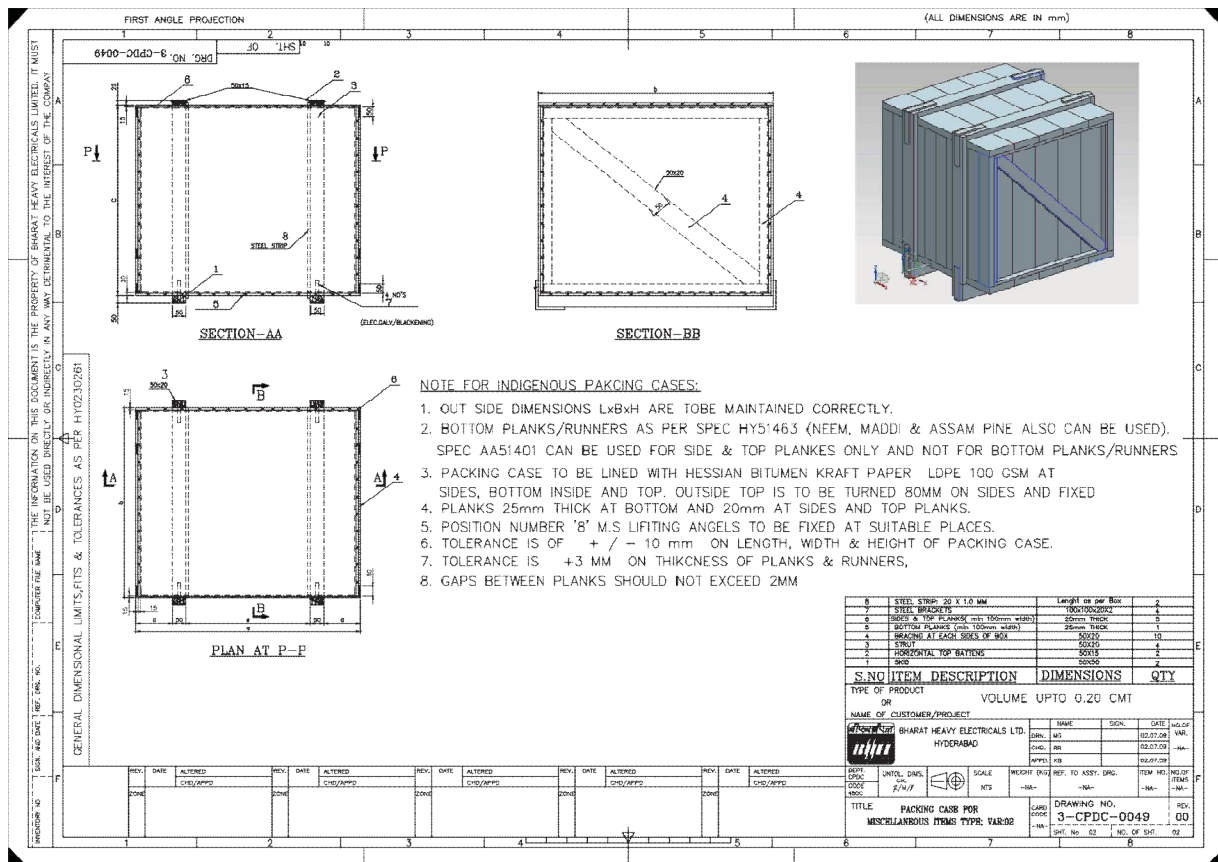
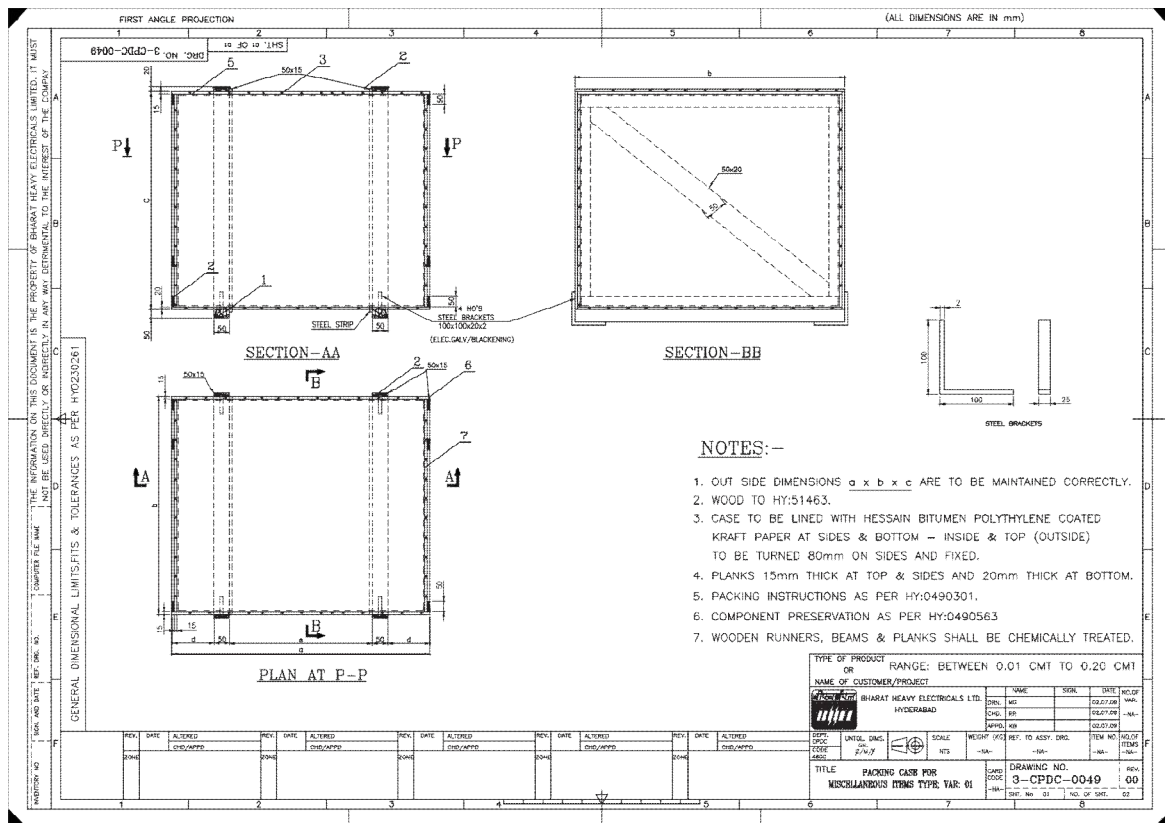

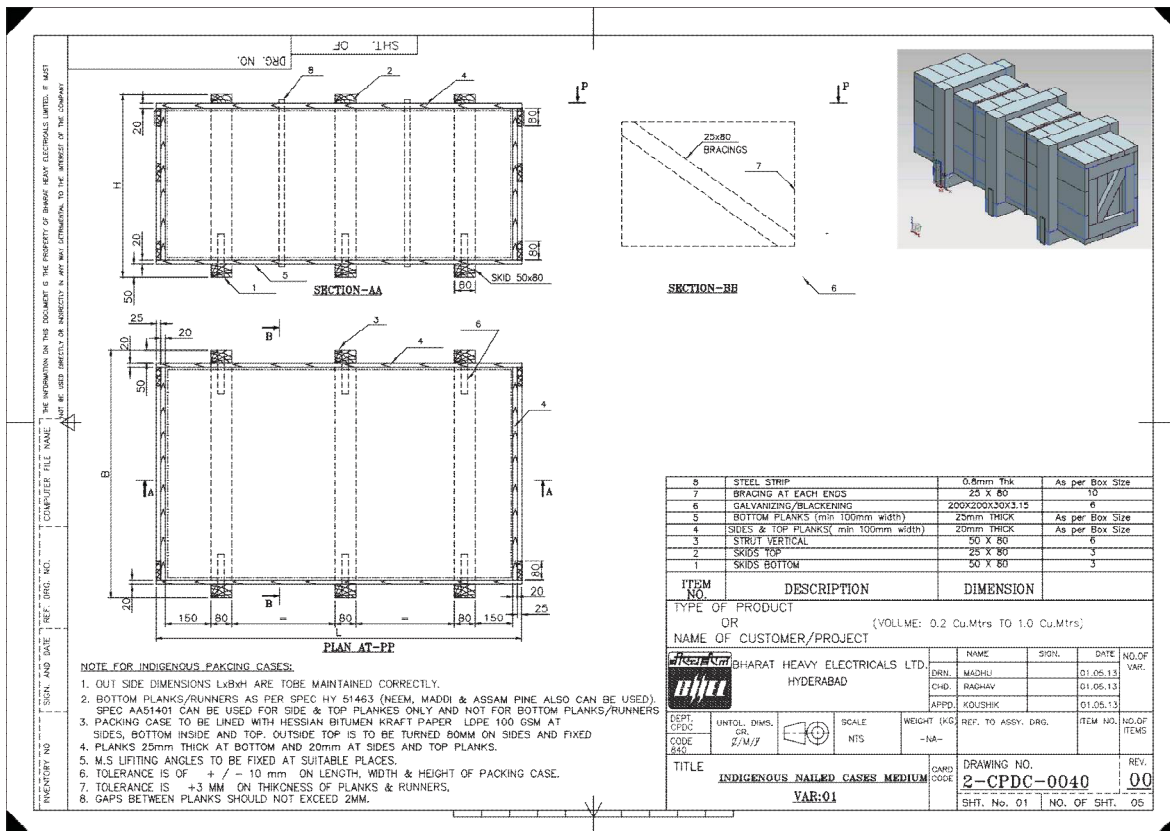
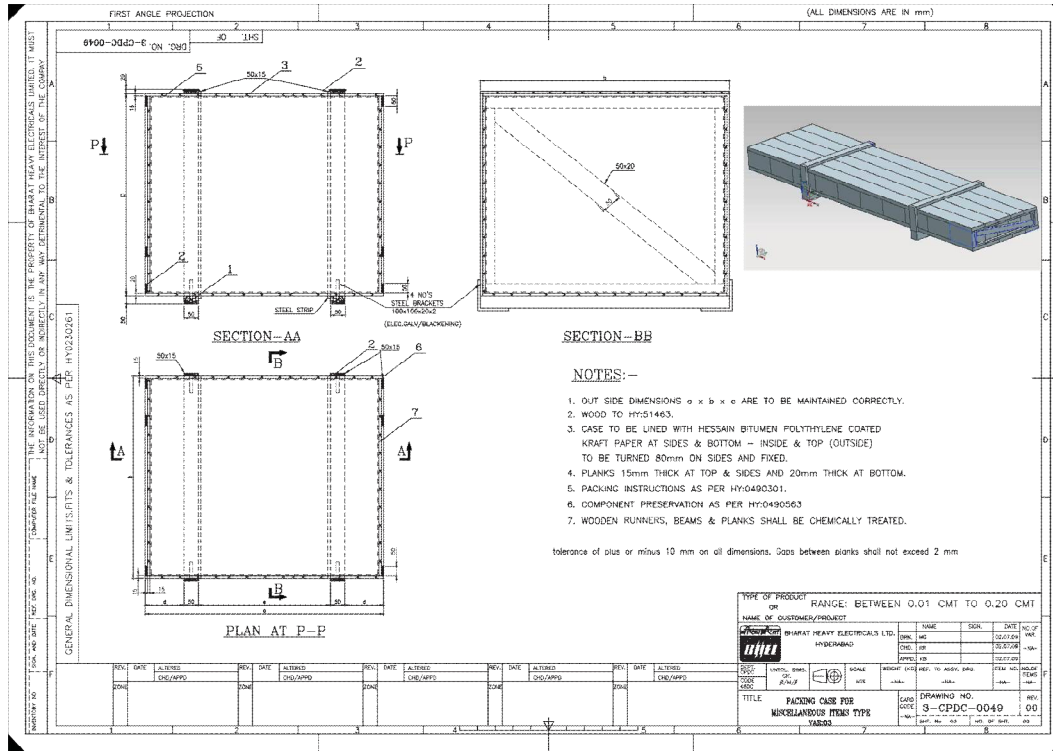

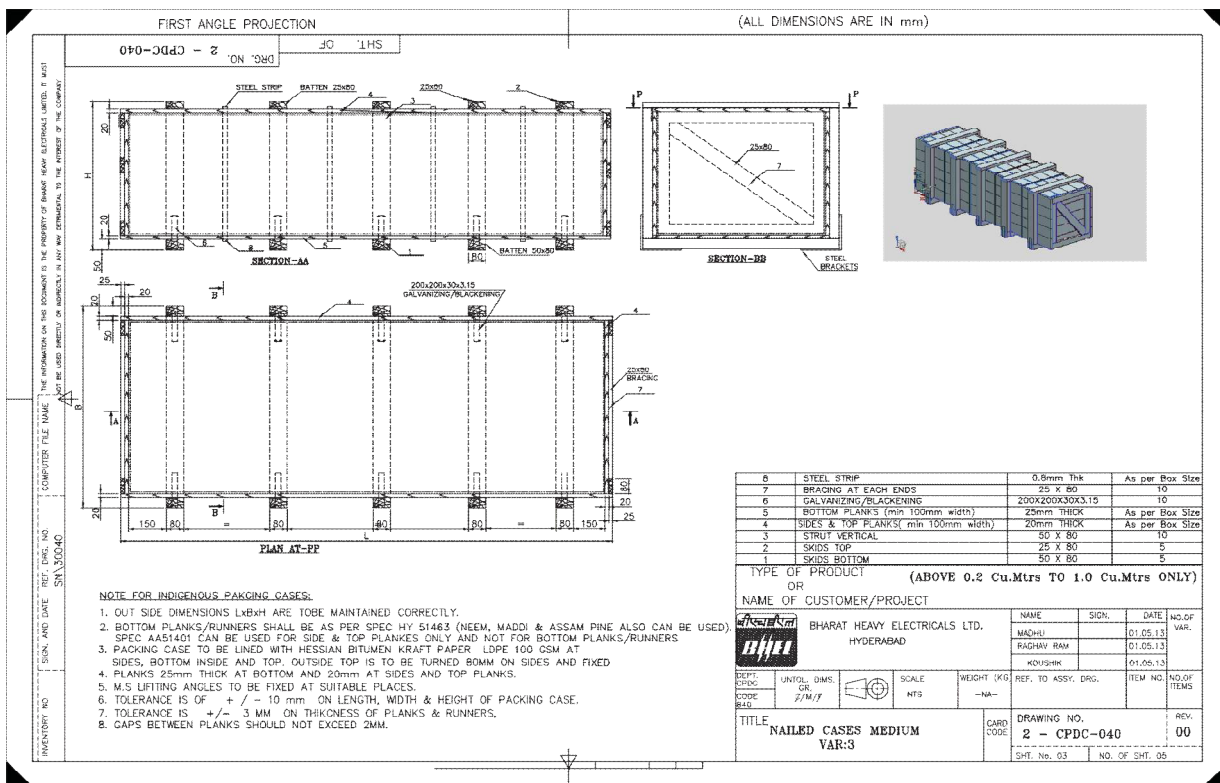
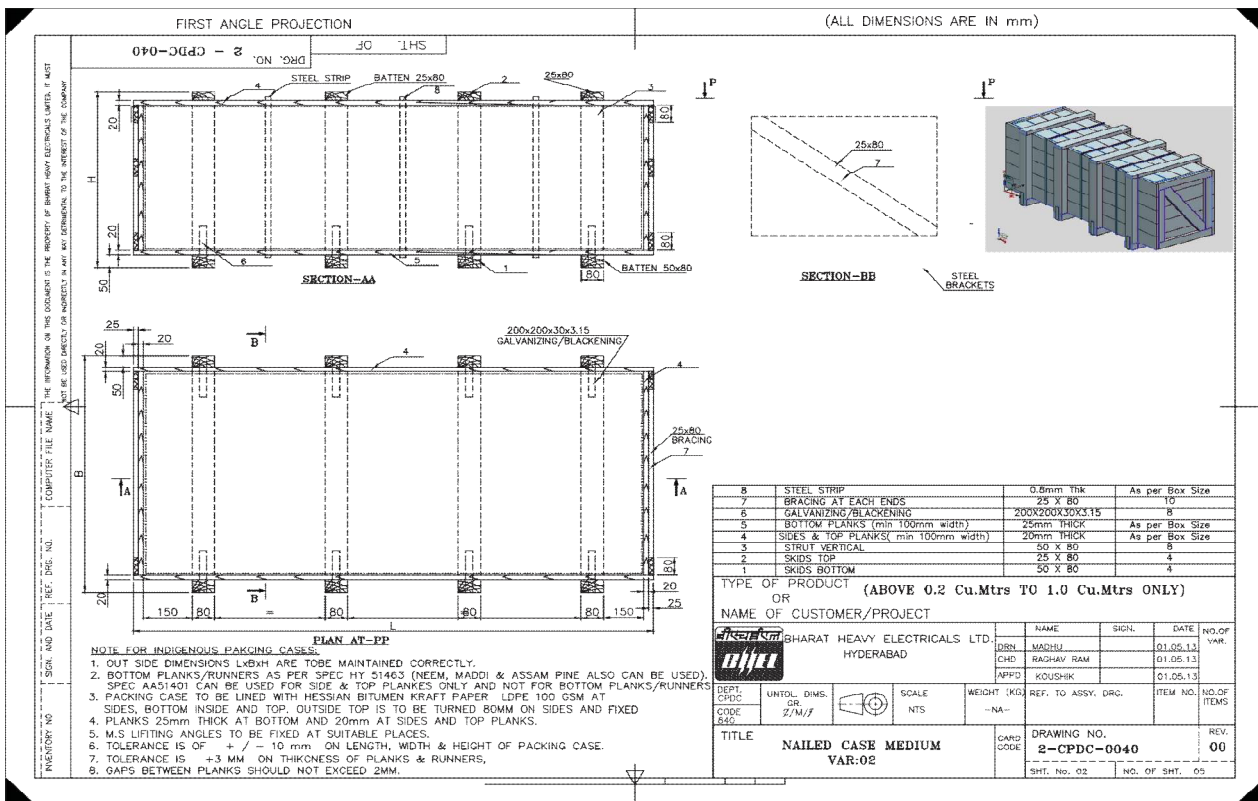

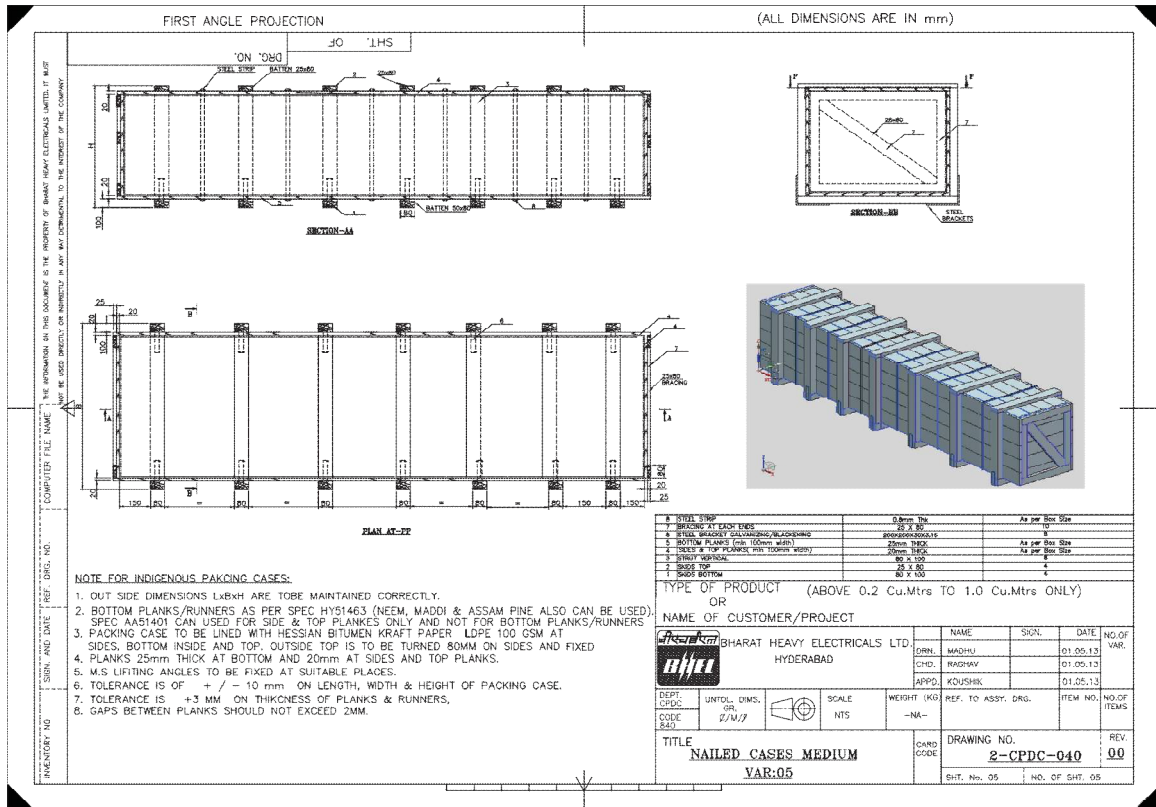
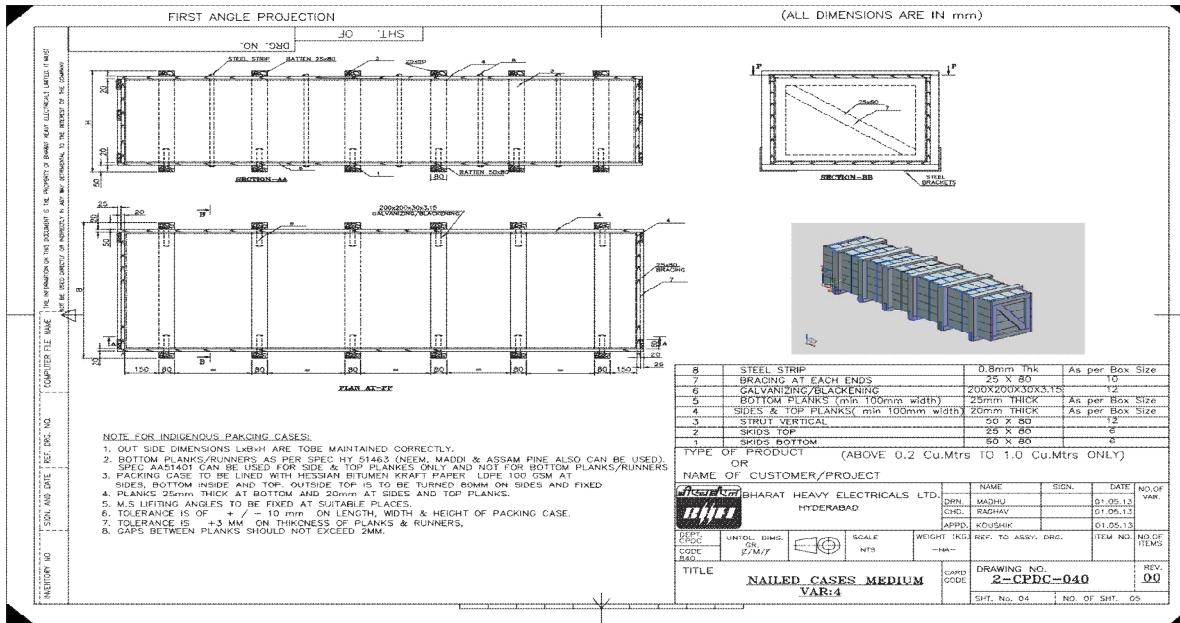

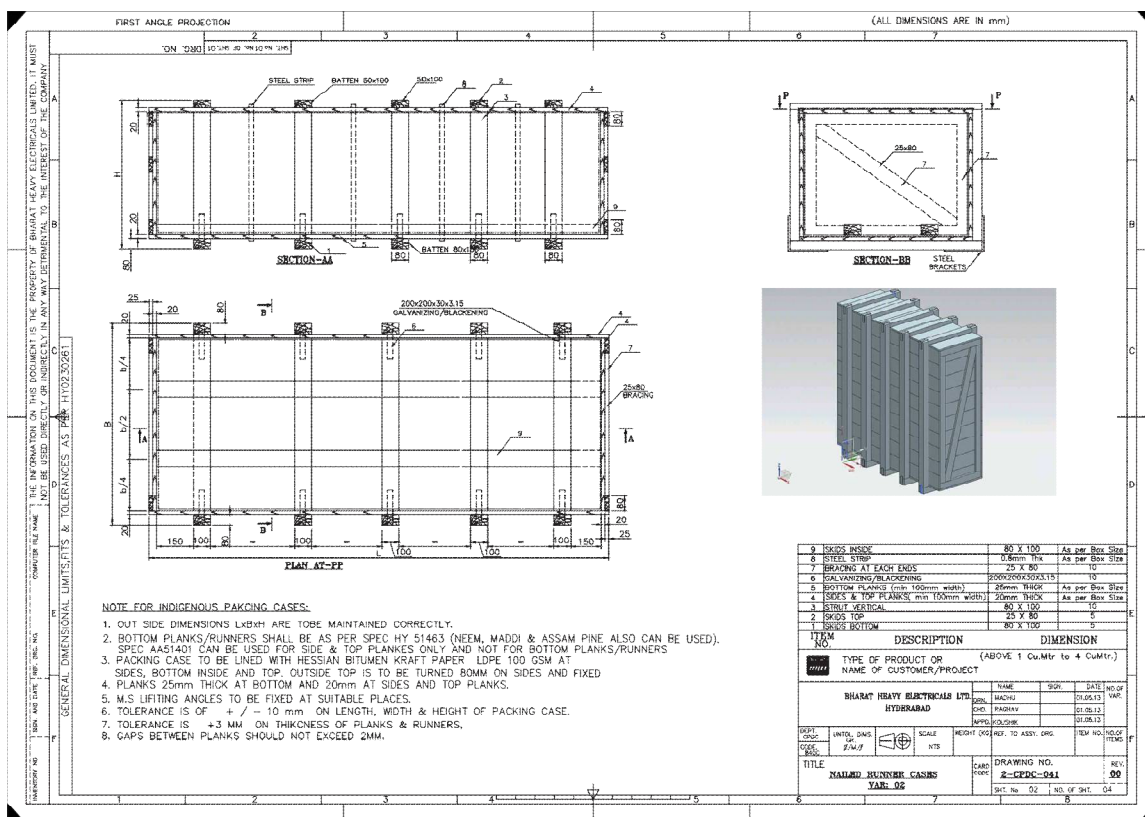
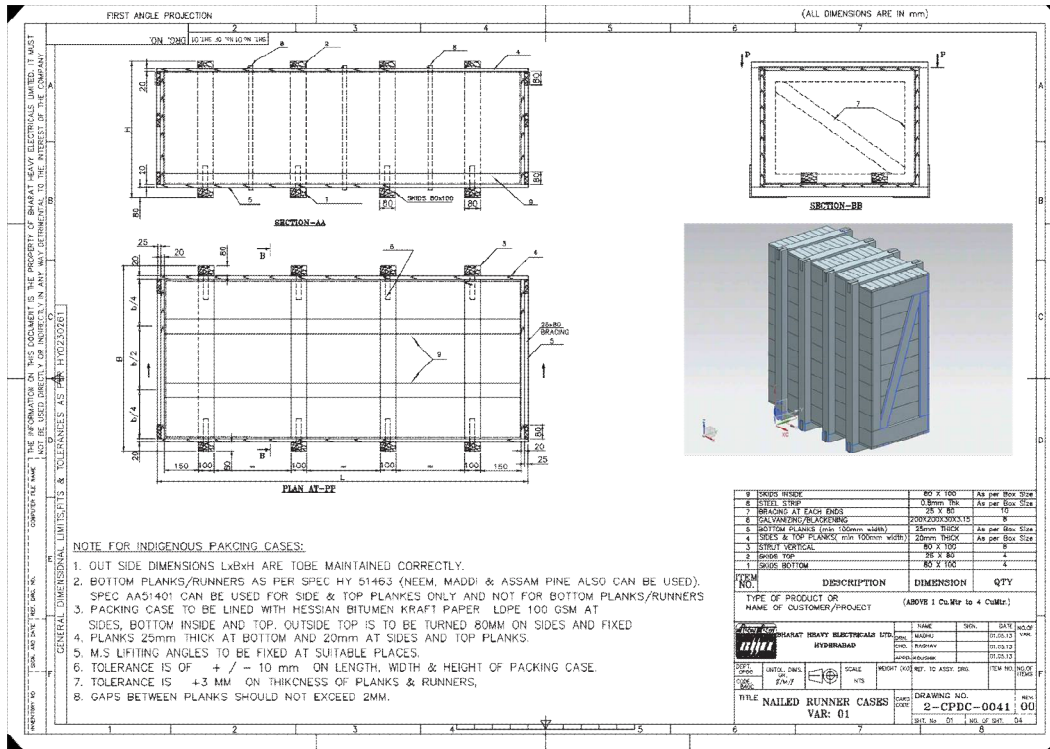

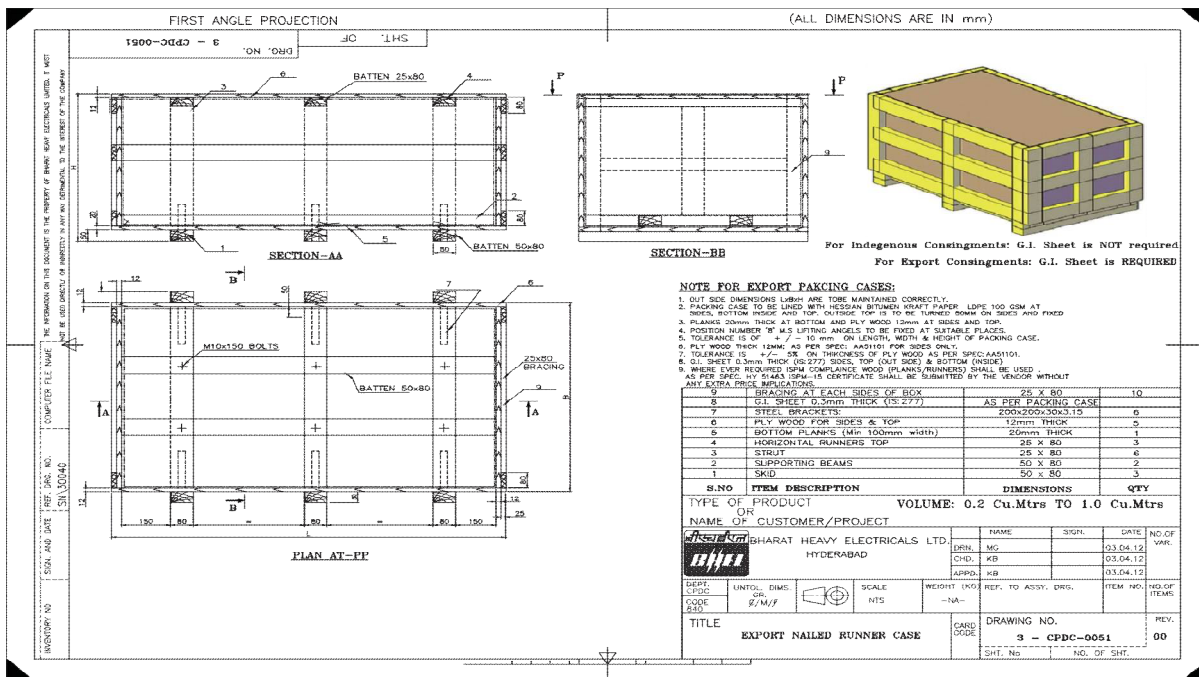
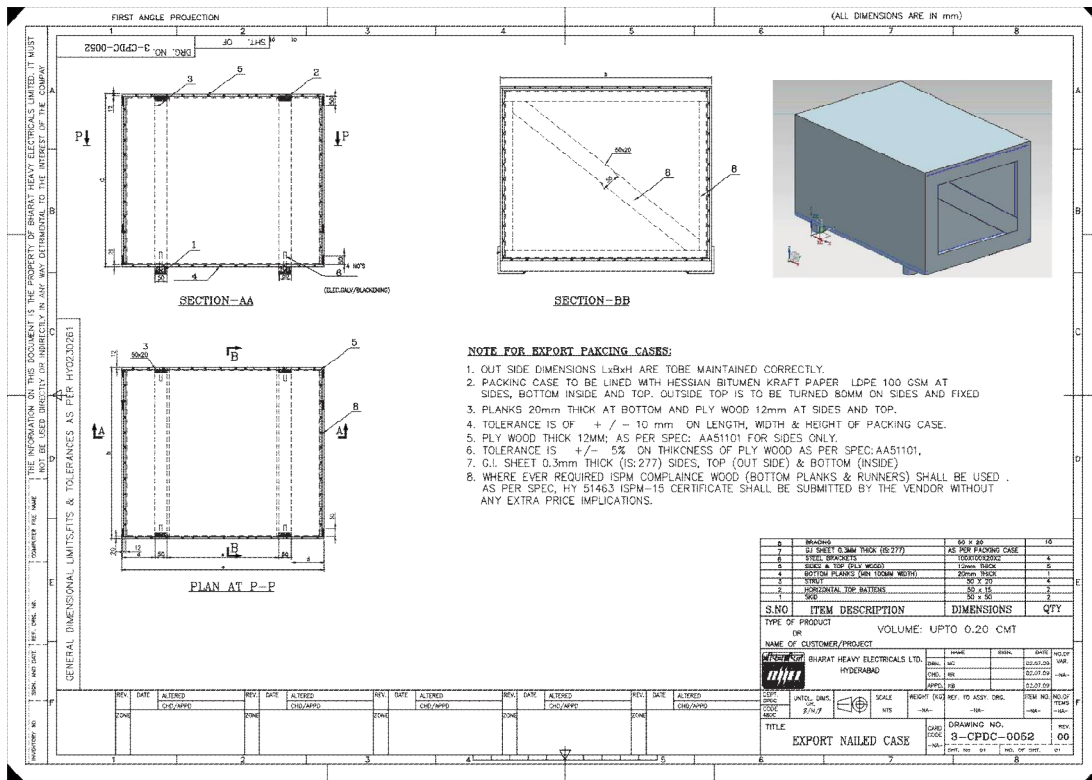

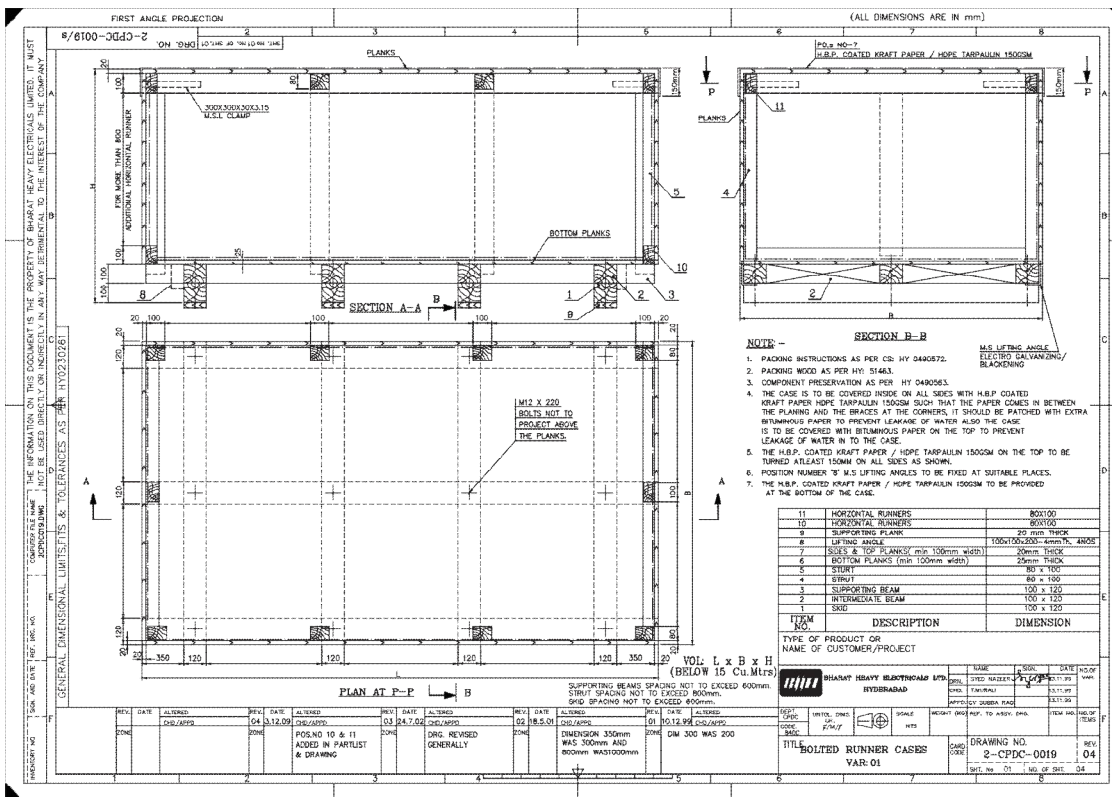
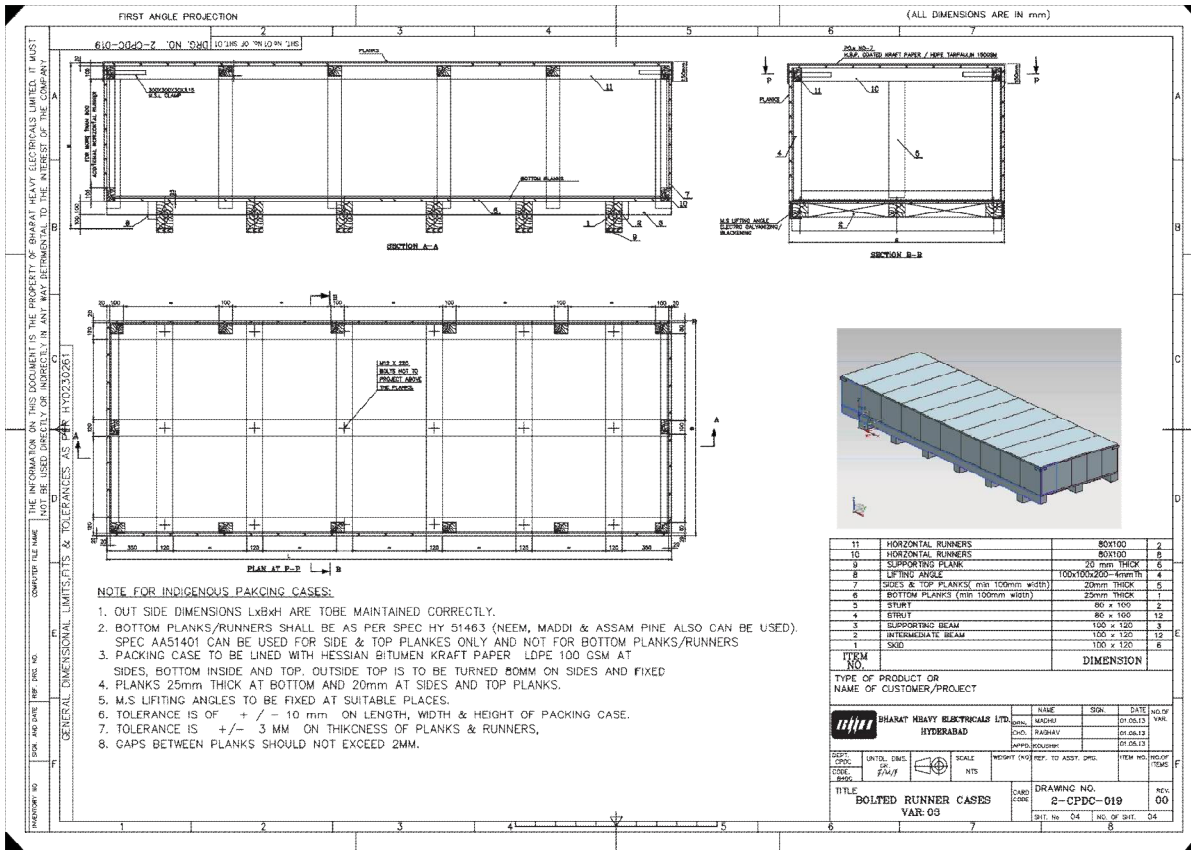

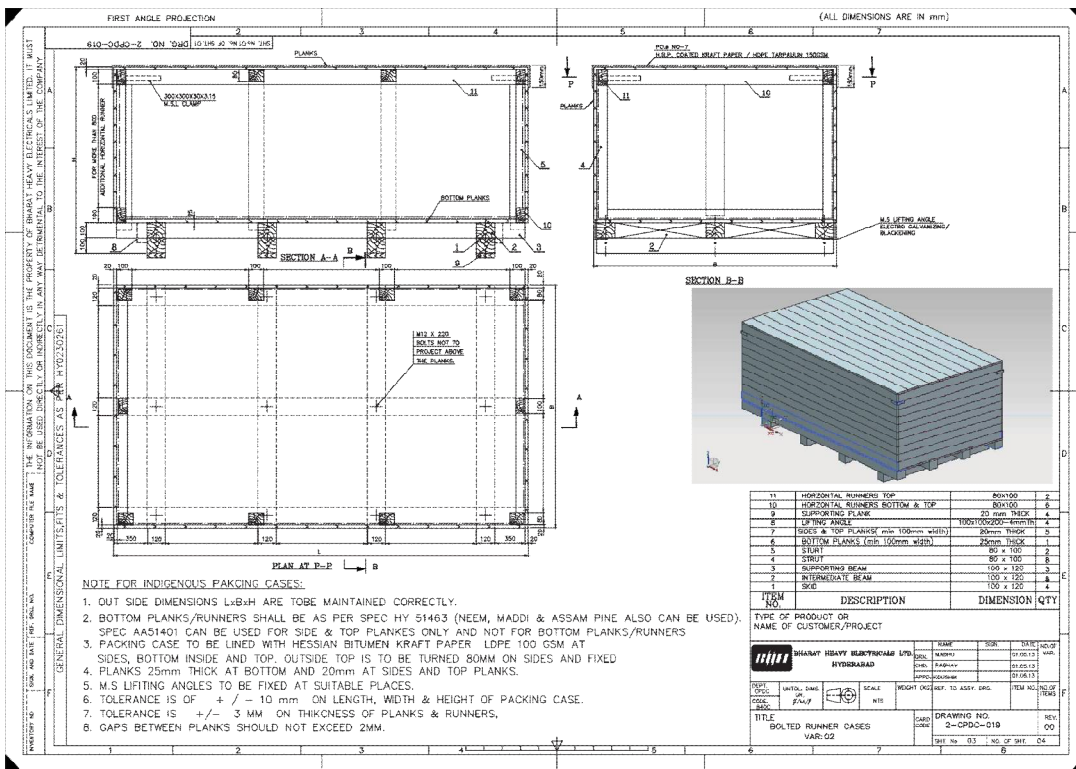
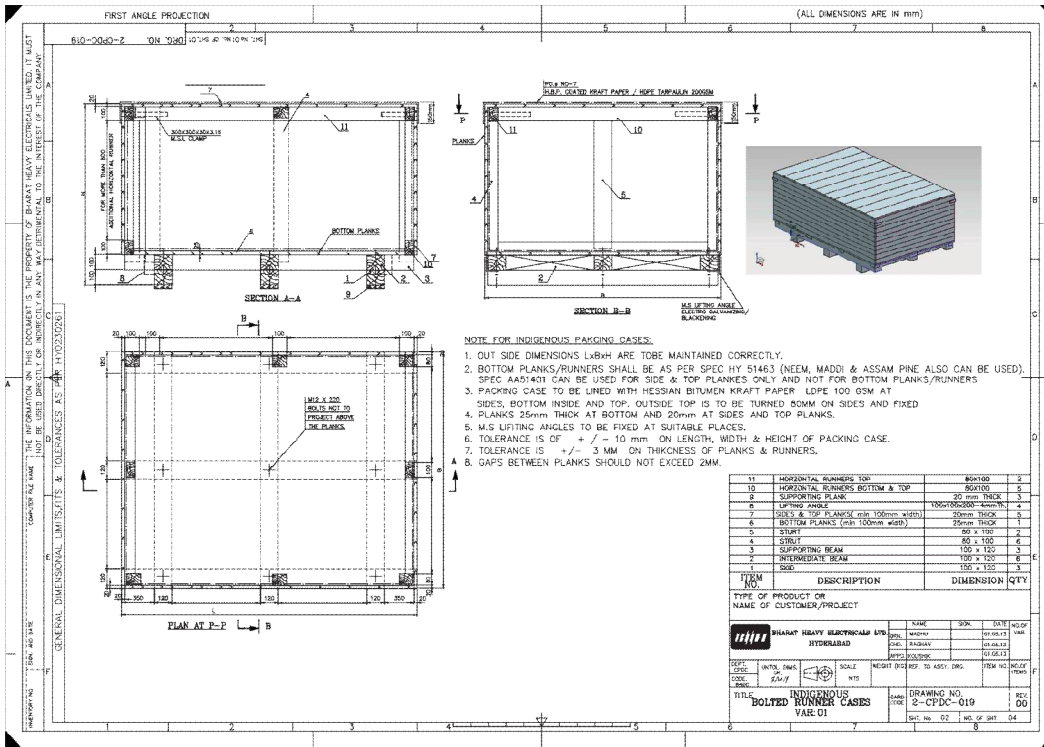

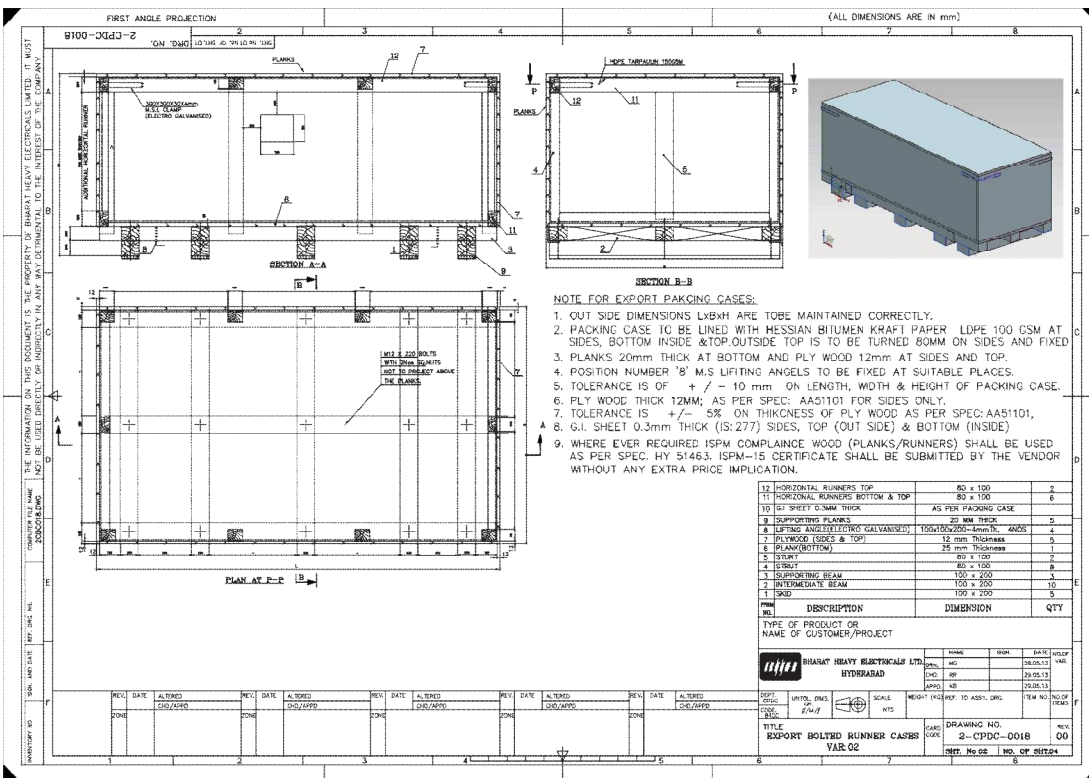
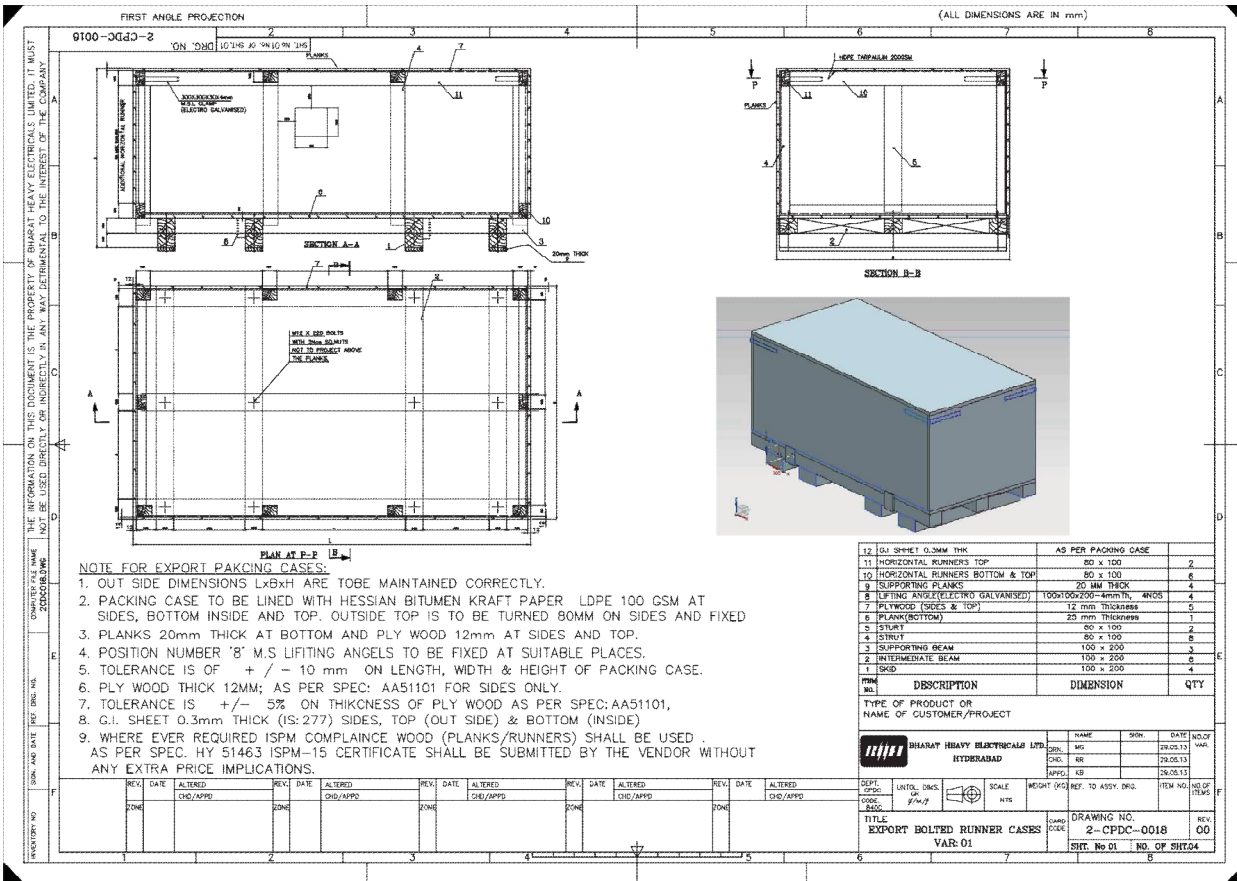

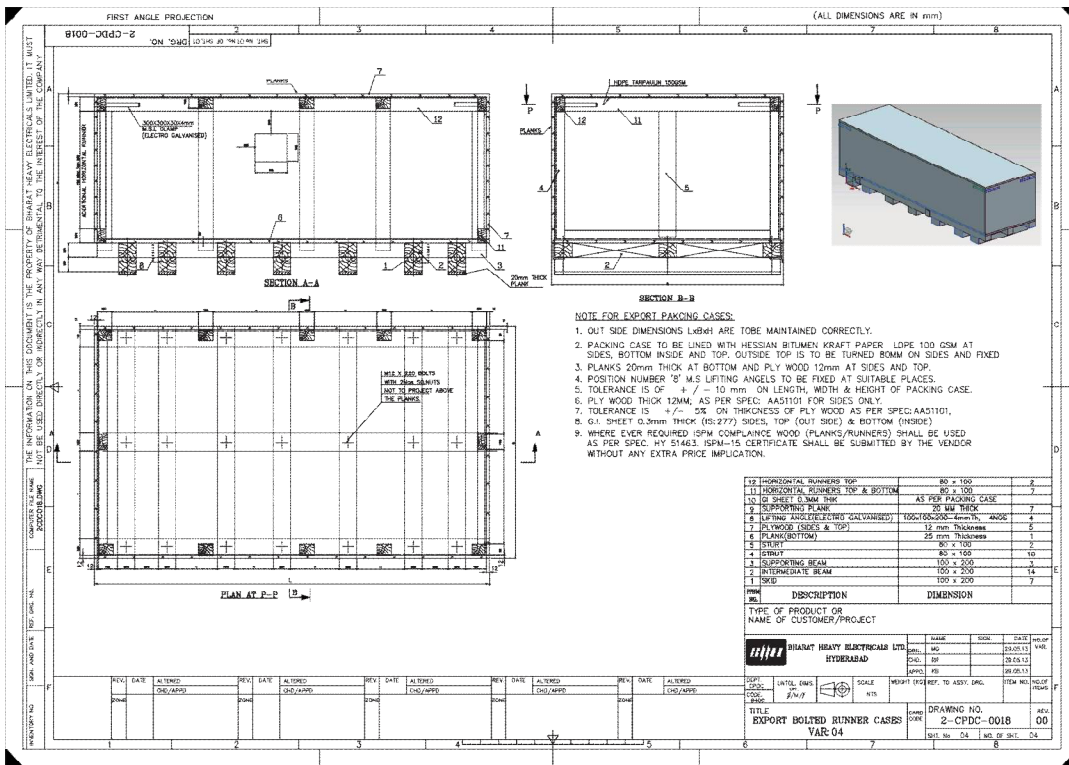
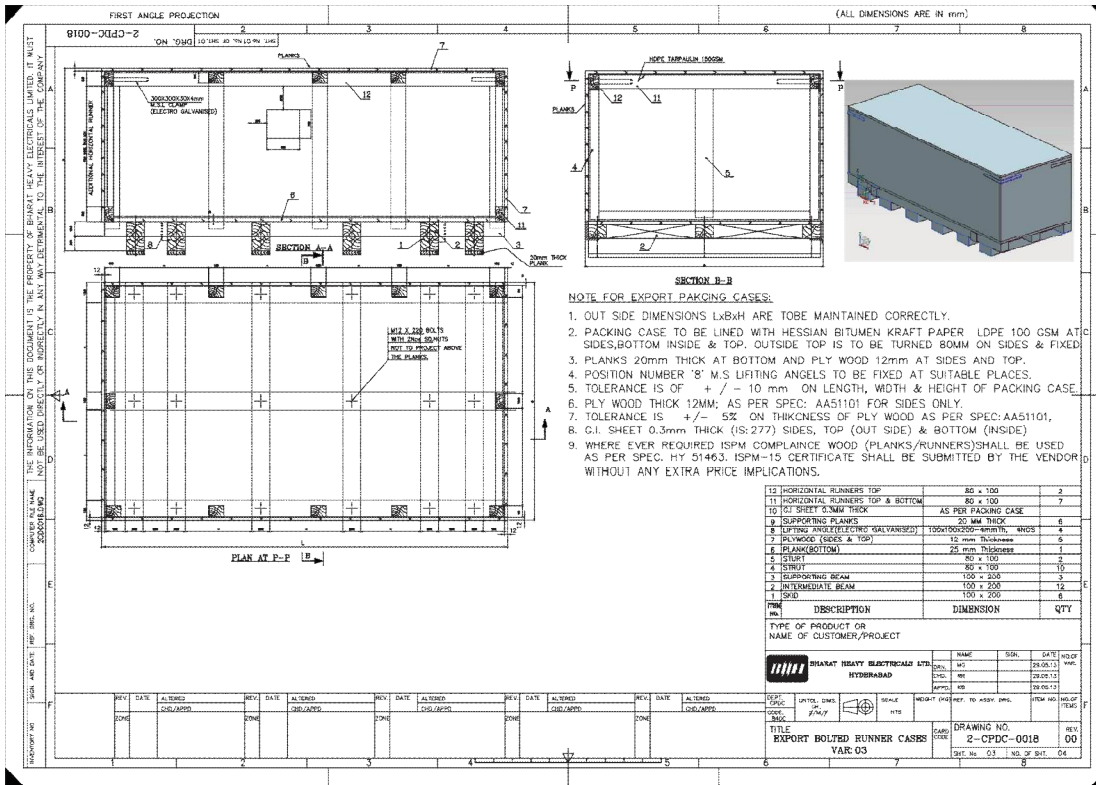

FIRST ANGLE PROJECTION		(ALL DIMENSIONS ARE IN mm)																															
REV.	DATE	ALTERED	REV.	DATE	ALTERED																												
		CHECKED			CHECKED																												
<p>GEN. DIM. LIMITS, FITS, & TOLERANCES AS PER P.S. :- HY0230261</p>																																	
<table border="1" style="width:100%; border-collapse: collapse;"> <tr> <th>Sl. No</th> <th>DESCRIPTION</th> <th>SIZE</th> <th>No.PCS</th> </tr> <tr> <td>6</td> <td>WOODEN BLOCK</td> <td>100 x 200 x 385</td> <td>1</td> </tr> <tr> <td>5</td> <td>VERICAL BEAM</td> <td>100x 80 x 350</td> <td>1</td> </tr> <tr> <td>4</td> <td>VERICAL BEAM</td> <td>80 x 100 x 960</td> <td>2</td> </tr> <tr> <td>3</td> <td>HORIZONTAL RUNNER</td> <td>100 x 100 x 3000</td> <td>2</td> </tr> <tr> <td>2</td> <td>HORIZONTAL RUNNER</td> <td>200 x 100 x 3000</td> <td>2</td> </tr> <tr> <td>1</td> <td>HORIZONTAL RUNNER</td> <td>80 x 100 x 1900</td> <td>2</td> </tr> </table>						Sl. No	DESCRIPTION	SIZE	No.PCS	6	WOODEN BLOCK	100 x 200 x 385	1	5	VERICAL BEAM	100x 80 x 350	1	4	VERICAL BEAM	80 x 100 x 960	2	3	HORIZONTAL RUNNER	100 x 100 x 3000	2	2	HORIZONTAL RUNNER	200 x 100 x 3000	2	1	HORIZONTAL RUNNER	80 x 100 x 1900	2
Sl. No	DESCRIPTION	SIZE	No.PCS																														
6	WOODEN BLOCK	100 x 200 x 385	1																														
5	VERICAL BEAM	100x 80 x 350	1																														
4	VERICAL BEAM	80 x 100 x 960	2																														
3	HORIZONTAL RUNNER	100 x 100 x 3000	2																														
2	HORIZONTAL RUNNER	200 x 100 x 3000	2																														
1	HORIZONTAL RUNNER	80 x 100 x 1900	2																														
SIGN. AND DATE	REF. DRG. NO.	REMARKS	ITEM NO.	DESCRIPTION	STD.																												
				<table border="1" style="width:100%; border-collapse: collapse;"> <tr> <th>MATL. CODE</th> <th>A</th> <th>UNIT</th> <th>UNIT Wt.</th> </tr> <tr> <td></td> <td>C</td> <td></td> <td></td> </tr> <tr> <th>MATL. SPEN.</th> <th>C</th> <th>UNIT</th> <th>QTY.</th> </tr> <tr> <td></td> <td></td> <td></td> <td></td> </tr> </table>		MATL. CODE	A	UNIT	UNIT Wt.		C			MATL. SPEN.	C	UNIT	QTY.																
MATL. CODE	A	UNIT	UNIT Wt.																														
	C																																
MATL. SPEN.	C	UNIT	QTY.																														
		BHARAT HEAVY ELECTRICALS LTD. HYDERABAD		<table border="1" style="width:100%; border-collapse: collapse;"> <tr> <th>NAME</th> <th>SIGN.</th> <th>DATE</th> <th>NO.OF VAR.</th> </tr> <tr> <td>DRN. MG</td> <td></td> <td>27.11.12</td> <td></td> </tr> <tr> <td>CHD. RR</td> <td></td> <td>27.11.12</td> <td></td> </tr> <tr> <td>APPD. KB</td> <td></td> <td>27.11.12</td> <td></td> </tr> </table>		NAME	SIGN.	DATE	NO.OF VAR.	DRN. MG		27.11.12		CHD. RR		27.11.12		APPD. KB		27.11.12													
NAME	SIGN.	DATE	NO.OF VAR.																														
DRN. MG		27.11.12																															
CHD. RR		27.11.12																															
APPD. KB		27.11.12																															
DEPT. CODE	UNTL. DIM GR. R/H/P		SCALE	WEIGHT (KGS)	REF. TO ASSY DRG.																												
TITLE WOODEN SUPPORT FOR BOWL & BOWL HUB ASSLY				DRAWING NO. 4-94-67-0527	REV. 00																												
				SHT No.	NO OF SHT.																												

THE INFORMATION ON THIS DOCUMENT IS THE PROPERTY OF BHARAT HEAVY ELECTRICALS LIMITED. IT MUST NOT BE USED DIRECTLY OR INDIRECTLY IN ANY WAY DETRIMENTAL TO THE INTEREST OF THE COMPANY

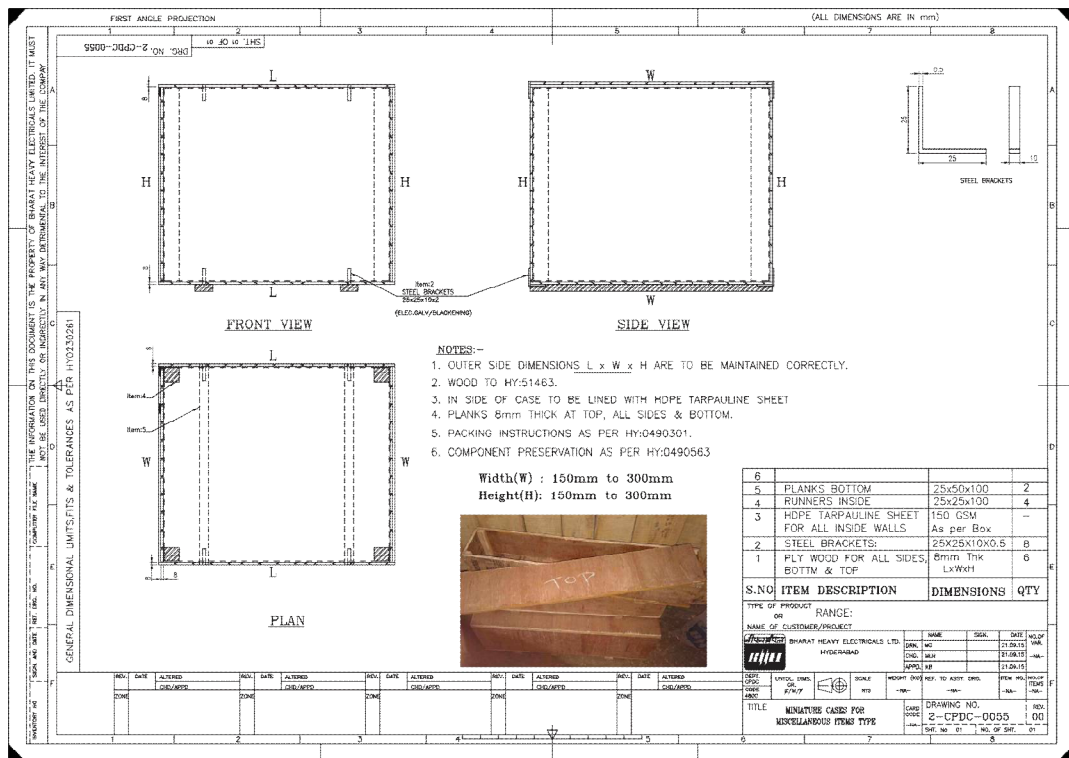
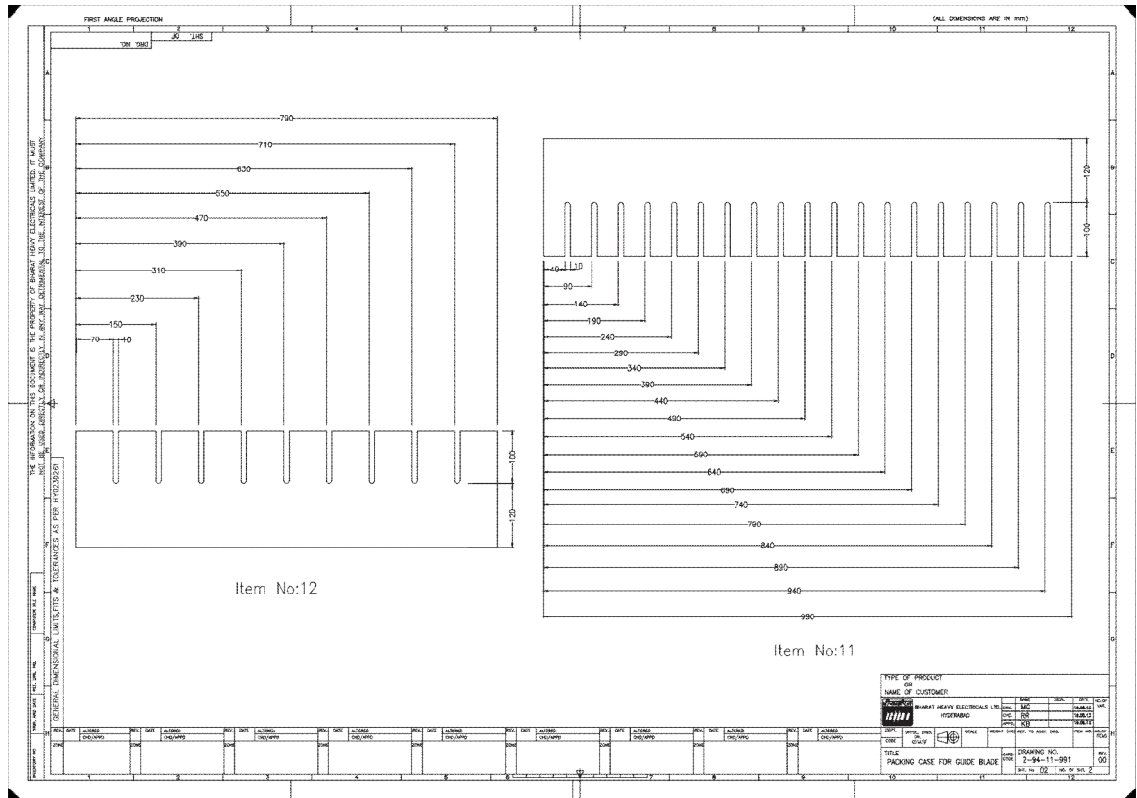

FIRST ANGLE PROJECTION		(ALL DIMENSICNS ARE IN mm)						
REV.	DATE	ALTERED	CHECKED	REV.	DATE	ALTERED	CHECKED	
<p style="text-align: center;">NOTE:- 1. PACKING INSTRUCTIONS AS PER HY : 0490572</p>								
		2		Length: 200MM				4
		1		100 X 200 X 500				4
		REMARKS	ITEM NO.	DESCRIPTION	SIZE		QTY.	
		BHARAT HEAVY ELECTRICALS LTD. HYDERABAD		DRN.	MG	SIGN.	DATE	NO.OF VAR.
				CHD.	MLN		15.10.15	
				APPD.	KB		15.10.15	
DEPT. CPDC	UNTOL. DIM. GR. C/MIE/		SCALE NTS	WEIGHT (KG) NA	REF. TO ASSY DRG.		ITEM NO.	NO.OF ITEMS NA
CODE 480C	TITLE WOODEN SUPPORTS FOR JOURNAL OPENING COVER; SEPERATOR TOP & SEPERATOR BODY			CARD CODE	DRAWING NO. 2-CPDC-0059		REV. 00	
						SHT No.	NO OF SHT.	

THE INFORMATION ON THIS DOCUMENT IS THE PROPERTY OF BHARAT HEAVY ELECTRICALS LIMITED.
 IT MUST NOT BE USED DIRECTLY OR INDIRECTLY IN ANY WAY DETRIMENTAL TO THE INTEREST OF THE COMPANY

GEN. DIM. LIMITS , FITS , & TOLERANCFS AS PER P.S. :- HY0230261

INVENTORY NO. SIGN. AND DATE REF. DRG. NO.

FIRST ANGLE PROJECTION (ALL DIMENSIONS ARE IN mm)

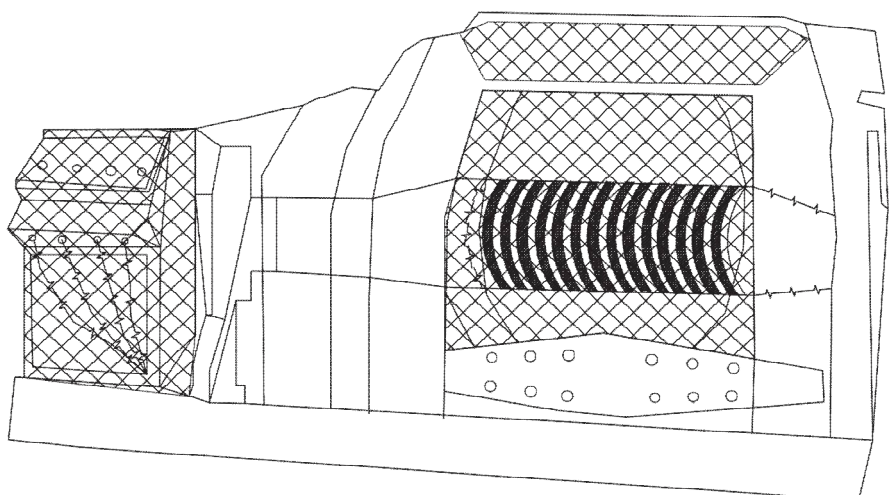
REV.	DATE	ALTERED CHECKED	REV.	DATE	ALTERED CHECKED
					
<p>NOTE:-</p> <p>1. PACKING INSTRUCTIONS AS PER HY : 0490572</p>					
		2	PLY WOOD SHEET	20X1220X2440	2 Nos
		1	PLY WOOD SHEET	20X1220X2440	2 Nos

REMARKS	ITEM NO	DESCRIPTION	SIZE	QTY.
 BHARAT HEAVY ELECTRICALS LTD. HYDERABAD				
			NAME	SIGN.
			DATE	NO. OF VAR.
			DRN. MG	15.10.15
			CHD. MLN	15.10.15
			APPD. KB	15.10.15
DEPT. CPDC	UNTOL. DIM. GR. /C/M/F/	SCALE NTS	WEIGHT (KG) NA	REF. TO ASSY DRG.
CODE 480C				ITEM NO.
TITLE			DRAWING NO.	REV.
WOODEN SUPPORTS DRAW WORKS			2-CPDC-0063	00
			SHT No.	NO OF SHT.

THE INFORMATION ON THIS DOCUMENT IS THE PROPERTY OF BHARAT HEAVY ELECTRICALS LIMITED.
 IT MUST NOT BE USED DIRECTLY OR INDIRECTLY IN ANY WAY DETRIMENTAL TO THE INTEREST OF THE COMPANY
 GEN. DIM. LIMITS, FITS, & TOLERANCES AS PER P.S. :- HY0230261

FIRST ANGLE PROJECTION

DIMENSIONS ARE IN

PROPERTY OF BHARAT HEAVY ELECTRICALS LIMITED

THE INFORMATION ON THIS DOCUMENT IS THE PROPERTY OF BHARAT HEAVY ELECTRICALS LIMITED. IT MUST NOT BE USED DIRECTLY OR INDIRECTLY IN ANY WAY DETRIMENTAL TO THE INTEREST OF THE COMPANY.

REV. DATE ALTERED CHECKED

REV. DATE ALTERED CHECKED

AS PER P.S. : HY0230261

GEN. DIM. LIMITS, FITS, & TOLERANCE

NOTE FOR EXPORT PACKING CASES:

INSTRUCTIONS AS PER HY : 0490572

(ALL DIMENSIONS ARE IN mm)

FIRST ANGLE PROJECTION

ARROYE PICTURE IS INDICATIVE ONLY

For Indigenous Consignments: G.I. Sheet is NOT required
For Export Consignments: G.I. Sheet is REQUIRED

S. NO	ITEM DESCRIPTION	DIMENSIONS	QTY
0	BRACING AT SIDES OF BOX	25 X 80	10
0	G.I. SHEET 0.3mm THICK (IS 277)	AS PER PACKING CASE	
7	STEEL BRACKET	200x200x50x3 16	6
6	PLY WOOD FOR SIDES & TOP	12mm THICK	5
0	BOTTOM PLANKS (Min 100mm width)	20mm THICK	1
4	HORIZONTAL RUNNERS TOP	50 X 100	3
3	STRUT	25 X 80	6
2	SUPPORTING BEAM	50 X 80	2
1	SKID	100 X 80	1

(ABOVE 1 Cu.Mtr. TO 4 Cu.Mtr.)

NAME OF CUSTOMER/PROJECT		NAME	SIGN.	DATE	NO. OF VAR.
BHARAT HEAVY ELECTRICALS LTD. HYDERABAD		DRN. MG		21.11.02	
		CHD. MLN		21.11.02	
		APPD. KB		21.11.02	

DEPT. CODE	UNTO. DIM. GR. C/M/F	SCALE	WEIGHT (KG)	REF. TO ASSY. DRG.	ITEM NO.	NO. OF ITEMS
CPDC 480C		NTS	NA			

TITLE		CARD CODE	DRAWING NO.	REV.
EXPORT NAILED RUNNER CASE <td></td> <td>3 - CPDC-0050</td> <td>00</td>			3 - CPDC-0050	00
		SHT. No.	NO. OF SHT.	

REF. DRG. NO.	ITEM NO	DESCRIPTION	SIZE	QTY.
	2	Bolts M20	Length: 500MM	4
	1	WOODEN RUNNERS	100 X 200 X 2500	6

REMARKS	ITEM NO	DESCRIPTION	SIZE	QTY.

SIGN. AND DATE		NAME	SIGN.	DATE	NO. OF VAR.
 BHARAT HEAVY ELECTRICALS LIMITED HYDERABAD		DRN.	MG	15.10.15	
		CHD.	MLN	15.10.15	
		APPD.	KB	15.10.15	

DEPT. CODE	UNTO. DIM. GR. C/M/F	SCALE	WEIGHT (KG)	REF. TO ASSY. DRG.	ITEM NO.	NO. OF ITEMS
CPDC 480C		NTS	NA			

TITLE		CARD CODE	DRAWING NO.	REV.
FOR MILL SHELL			2-CPDC-0064	00
		SHT. No.	NO OF SHT.	

23.0 Price Bid(Estimated)

Tender Notice No: HY/LOG/PKG/2022/01 Dt. 21.12.2021

Name of the work: Packaging of finished goods at Logistics

SNo	Schedule Description	Measuring Unit	Schedule	Scope of work	Unit rate (Rs.)	QTY FOR ONE YR	VALUE FOR ONE YR(INR)
1	Nailed cases small (vol<0.2 cub.m.) DWG No:3-CPDC-0049	Cub.m.	1A	Box Making Cost	81	1680.92	136154.52
		Cub.m.	1B	Loading, Packing & addressing	176	795.24	139962.24
2	Nailed cases medium (0.2cub.m.<vol < 1 cub.m.)DWG No:3-CPDC-0040	Cub.m.	2A	Box Making Cost	289	1556.41	449802.49
		Cub.m.	2B	Loading, Packing & addressing	619	795.24	492253.56
3	Nailed runner cases (vol>1 cub.m.) DWG No:3-CPDC-0041	Cub.m.	3A	Box Making Cost	357	884.04	315602.28
		Cub.m.	3B	Loading, Packing & addressing	730	795.24	580525.2
4	Export nailed cases small (vol<0.2 cub.m.)DWG No:3-CPDC-0052	Cub.m.	4A	Box Making Cost	1	1680.92	1680.92
		Cub.m.	4B	Loading, Packing & addressing	2	795.06	1590.12
5	Export nailed cases medium(0.2 cub.m.<vol<1 cub.m.)DWG No:3-CPDC-0051	Cub.m.	5A	Box Making Cost	11	1556.41	17120.51
		Cub.m.	5B	Loading, Packing & addressing	15	795.24	11928.6
6	Export nailed runner cases (vol>1cub.m.)DWG No:3-CPDC-0050	Cub.m.	6A	Box Making Cost	36	896.49	32273.64
		Cub.m.	6B	Loading, Packing & addressing	47	795.06	37367.82
7	Bolted runner cases(wt>600kg) DWG No:3-CPDC-0019	Cub.m.	7A	Box Making Cost	738	892.75	658849.5
		Cub.m.	7B	Loading, Packing & addressing	1118	537.14	600522.52
8	Export Bolted runner cases(wt>600kg)DWG No:2-CPDC-0018	Cub.m.	8A	Box Making Cost	51	906.45	46228.95
		Cub.m.	8B	Loading, Packing & addressing	54	537.14	29005.56
9	Switchgear Crates (Base unit, insulator,interruptor)	Cub.m.	9A	Box Making Cost	23	622.56	14318.88
		Cub.m.	9B	Loading, Packing & addressing	25	795.24	19881
10	Bowl & Bowl hub frames	Nos.	10B	Loading, Packing & addressing	37	792.77	29332.49
11	Cardboard boxes (personal collection)	Cub.m.	11B	Loading, Packing & addressing	2	88.37	176.74
12	Primary Packing (Critical components)	Sq.m.	12B	Packing	8052	261.41	2104873.32
13	Plywood enclosure (Critical components)	Sq.m.	13A	Box Making Cost	1887	328.71	620275.77
		Sq.m.	13B	Loading, Packing & addressing	2230	132.54	295564.2
14	Open items	Nos.	14B	addressing	3133	93.01	291400.33

15	Modifications to incoming boxes and other wooden preparatory works	Sq.m.	15B	Dismantling of Packing	672	132.54	89066.88
16	Export Plywood cum GI sheet enclosure (Critical components)	Sq.m.	16A	Box Making Cost	1856	341.17	633211.52
		Sq.m.	16B	Loading, Packing & addressing	2084	236.57	493011.88
17	Medium sized Plywood packing cases for air freight transport	Cub.m.	17A	Box Making Cost	8	328.71	2629.68
		Cub.m.	17B	Loading, Packing & addressing	11	795.06	8745.66
18	Pigeon hole packing cases	Cub.m.	18A	Box Making Cost	1	328.71	328.71
		Cub.m.	18B	Loading, Packing & addressing	1	795.06	795.06
19	Draw works assembly opening covers	Nos.	19A	Box Making Cost	1	442.02	442.02
		Nos.	19B	Loading, Packing & addressing	29	792.9	22994.1
20	Vacuum packing (Critical components)	Sq.m.	20B	Packing	8	261.41	2091.28
21	Foam Packing (Instruments)	Sq.m.	21B	Packing	1	62.26	62.26
22	Metallic enclosure (Material scope with Product group)	Sq.m.	22B	Loading, Packing & addressing	2254	132.5	298655
23	Crate/Pallet With Bale Patti	Sq.m.	23A	Box Making Cost	1	54.5	54.5
			23B	Loading, Packing & addressing	49	27.25	1335.25
24	Only GI Sheet Packing And Addressing For Wooden Box	Sq.m.	24B	Loading, Packing & addressing	1	236.57	236.57
25	V Groove Stand For Journal Springs & Addressing	EA	25B	Loading, Packing & addressing	4	186.02	744.08
26	Plywood Fitting For Journal Head Openings & Addressing	EA	26B	Loading, Packing & addressing	2	279.04	558.08
27	Nails Removal From Incoming Wood	KGS	27B	NAILS REMOVAL FROM INCOMING WOOD	1	2.73	2.73
28	Only Addressing On Export Boxes/Open Items (Stensile)	EA	28B	ONLY ADDRESSING ON EXPORT BOXES/OPEN ITEMS (STENSILE)	295	186.02	54875.9
29	Circular Saw Blades Sharpening From Outside Vendor	EA	29B	CIRCULAR SAW BLADES SHARPENING FROM OUTSIDE VENDOR	1	272.5	272.5

TOTAL(Rs.)= 85,36,805/-

NOTE:- THE QUANTITIES MENTIONED AGAINST EACH LINE ITEM ARE INDICATIVE. THEY MAY VARY BASED ON ACTUAL PACKING OF THE CONSIGNMENTS. BUT THE CONSOLIDATED ESTIMATION/CONTRACT VALUE REMAINS CONSTANT.

24.0 DECLARATION BY TENDERER

I, -----, aged ----- Yrs., S/o -----,
residing at -----

Hereby declare as follows:

- (i) That my nationality is _____.
- (ii) That I am a major and eligible to enter into contract / my firm / my company is competent to enter into an agreement.
- (iii) I shall employ only such personnel who have not been found unfit for employment in Organizations such as Central / state / Public undertaking by the Police Authorities.
- (iv) I shall not employ persons against whom Criminal cases are pending or under investigation.
- (v) I shall also not employ persons found guilty of offences involving moral turpitude for executing work in BHEL contracts.
- (vi) That there are no Criminal cases pending or under investigation against me or my firm or company.
- (vii) I have not been found guilty of offences involving moral turpitude nor any of the company directors / partners of my firm have been found guilty of offences involving moral turpitude.
- (viii) Neither I nor my firm nor my company has been declared insolvent in the past.
- (ix) I have taken due care and efforts to furnish only information which are true in the tender document.
- (x) I shall employ labours who are more than 18 years of age and having sound physical and mental health.
- (xi) I shall keep Photograph / identity proof / residential proof of the labourers to be employed against this tender and arrange for police verification.

[Signature with Name & seal of the Tenderer]