



**BHARAT HEAVY ELECTRICALS LIMITED**  
CORPORATE RESEARCH & DEVELOPMENT DIVISION  
VIKASNAGAR, HYDERABAD - 500 093, INDIA

PHONES:23774494 (EXT:9804)  
FAX : 91 40 23770698

RD:DP:MPX:F-04  
Ref: 412101611

ENQUIRY

Date 03-02-2022

Enquiry for **Machining & supply of DE mechanical components**

Enquiry No:412101611

Enquiry Date : 03-02-2022

Due Date: 03-03-2022

Indicative Delivery Date : 20-03-2022

Sl.No	Item Description	Unit	Qty
1	Machining and supply of DE mechanical components	SET	1

Please submit your quotation for the above material in sealed cover superscribed with enquiry no, enquiry date and due date subject to our enclosed terms and conditions. The quotations shall reach us on or before the due date by 12 noon. The tenders can also be dropped in the tender box kept at the security gate,BHEL R&D. In case you are not in position to submit the offer,please send reply suitably specifying the reasons.

Sl.No	Description	Document Ref.
01	Enquiry, PQC, General Terms & Conditions, Commercial Terms & Conditions etc.	Volume - 1
02	Technical specifications, Scope of Supply etc.	Volume - 2

Devsingh Vankudothu  
Manager  
devsingh@bhel.in

	<b>ENQUIRY &amp; QUALIFYING CRITERIA</b>	Volume - 1 Enquiry No 412101611
Machining & supply of DE mechanical components		

1	Tendor inviting officer / Authority, Designation and Address	Additional General Manager(MM) BHEL R & D, Vikas Nagar (Near Balanagar), Hyderabad -500093
2	Item Description - Qty	1) Machining and supply of DE mechanical components - 1 SET
3	Enquiry Reference no.	412101611
4	Indicative Delivery Date	20-03-2022
5	Due date, Time and place for submission of tender	03-03-2022 upto 12 noon. Sealed Quotations shall be addressed to Additional General Manager(MM), BHEL R & D Division, Vikas Nagar (Near Balanagar), Hyderabad AP,India Pin - 500 093 Quotations can also be deposited in the Tender box located at Security Gate of BHEL R & D BHEL shall not be responsible for any postal/courier delay.
6	Place, Date and time of Tech.Bid opening	Tender Opening Cell (Sangam) BHEL R & D Office. 03-03-2022, 2 PM
7	Mode of Submission of Tender	<p>Please submit your offer in one common sealed cover containing two parts in separate sealed covers as detailed below.</p> <p>1) First Cover shall contain:</p> <ol style="list-style-type: none"> <li>Signed General Terms &amp; Conditions (GTC)</li> <li>Filled and Signed Commercial Terms &amp; Conditions (CTC)</li> <li>Filled and Signed Vendor Specifications against BHEL Specifications (Item wise)</li> <li>Signed commercial bid</li> <li>Copy of Price-bid with price(s) cells blank (un-priced price bid) as per annexure</li> </ol> <p>2) Second cover shall contain Price Bid Containing Price quotes, applicable taxes, installation and/or commissioning charges shall be spelt out clearly taking into account total charges rather than quoting vaguely such as charges per man-day or charges per engineer per day etc as per annexure.</p> <p>If the price bid was found later to be different from the unpriced pricebid format in any way, the offer will be rejected summarily. The rates shall be quoted both in figures and in words.</p> <p>The offers can also be submitted through e-mail and have to be sent in PDF format (files with PDF extension only). Files having extensions other than PDF like RAR, EXE, JPEG etc. and with external links will not be considered. They have to be sent to e-mail id: 'rnd-eoffers@bhel.in' only. Copies should not be marked to anyone. If the offers are marked to anyone other than to eoffers, their offer will not be considered.</p> <p>The e-mail offers should have two attachments.</p> <p>1) One attachment shall contain</p> <ol style="list-style-type: none"> <li>Signed General Terms &amp; Conditions (GTC)</li> <li>Filled and Signed Commercial Terms &amp; Conditions (CTC)</li> <li>Filled and Signed Vendor Specifications against BHEL Specifications (Item wise)</li> <li>Signed commercial bid</li> <li>Copy of Price-bid with price(s) cells blank (un-priced price bid), as per annexure</li> </ol> <p>2) Second attachment shall contain Price Bid Containing Price quotes, applicable taxes, installation and/or commissioning charges shall be spelt out clearly taking into account total charges rather than quoting vaguely such as charges per man-day or charges per engineer per day etc as per annexure.</p> <p>The subject of the e-mail should contain Enquiry No, Enquiry Date and Due date.</p>



## GENERAL TERMS &amp; CONDITIONS (GTC)

Volume - 1  
Enquiry No  
412101611

Machining &amp; supply of DE mechanical components

SL.No.	Clause	BHEL REQUIREMENT
1	Preferences to MSEs	<p>The bidder may also be a Micro and Small Enterprises (MSE) vendor registered as per MSE act. As per the public procurement policy notified by the Central government.</p> <p>25% of the tendered quantity is earmarked for MSE suppliers in this tender. Out of the 25% tendered quantity reserved for MSE suppliers, 6.25% shall be earmarked for procurement from MSE owned by SC / ST entrepreneurs. Also 3% shall be earmarked for procurement from MSE owned by women.</p> <p>The definition of MSEs owned by women Entrepreneurs is clarified as under:</p> <ol style="list-style-type: none"> <li>In case of proprietary MSE, Proprietor shall be woman</li> <li>In case of partnership MSE, the women partners shall be holding at least 51% share in the unit.</li> <li>In case of private limited companies, at least 51% shall be held by Women Promoters.</li> </ol> <p>(Such enterprise will have to submit relevant document for proof of women ownership during offer submission)</p> <p>In case MSE vendor participating in the tender quotes within the price band of L1 + 15%, they will be allowed to supply the portion of the requirement subject to acceptance of L1 price by MSE vendor. In case of more than one such MSE, the supply shall be shared proportionately.</p> <p>"MSE suppliers can avail the intended benefits only if they submit along with the offer, attested copies of either EM II certificate having deemed validity (five years from the date of issue of acknowledgement in EM, II) or valid NSIC certificate or EM II certificate with due validity or Udyog Aadhar Number along with attested copy of a CA certificate (where deemed validity of EM II certificate of five years has expired) applicable for the relevant financial year (latest audited). Date to be reckoned for determining the deemed validity will be the date of bid opening (Part 1 in case of two part bid).</p> <p>Non submission of such documents will lead to consideration of their bid at par with other bidders. In case any improper / lack of documents is there vendor on their own interest may submit all the relevant documents as stated above, before tender opening. No benefit shall be applicable for this enquiry if any deficiencies in the above required documents are not submitted before tender opening. Documents should be notarized or attested by a Gazetted officer for consideration of MSE certificate. "</p> <p>Such Micro/Small Enterprises registered vendors must state the sub-category to which they belong and submit documentary proof for the same. The sub-categories: (a) Enterprises owned by Scheduled Castes. (b) Enterprises owned by Scheduled Tribes. (c) Enterprises owned by other than above two categories</p> <p>The enterprises under (a) &amp; (b) means the proprietor in case of single owned firm and all partners in case of partnership firm and all directors in case of private/public limited must belong to SC/ST category (Such enterprise will have to submit relevant document for proof of SC/ST category during offer submission) (Note: vendor need to go through General note Of tender condition also for any special instruction &amp; deviation from above.)</p> <p>If more than one valid MSE supplier stands with in rage of L1+15% range, 25% of quantity will be shared till quantity split is feasible &amp; rest of 25% will be awarded to lowest quote of valid MSE supplier.</p>
2	Preference to Make in India	<p>For this procurement, the local content to categorize a supplier as a Class 1 Local supplier / Class II Local supplier/ Non-Local supplier and purchase preference to Class 1 Local supplier, is as defined in Public Procurement (preference to Make in India), Order 2017 dated 04.06.2020 issued by DPIIT.</p> <p>In case of subsequent orders issued by the nodal ministry, changing the definition of local content for the items of the NIT, the same shall be applicable even if issued after issue of this NIT, but before opening of Part-II bids against this NIT</p>
3	Late Tenders	Tenders received after due date/time(12:00hrs) will not be considered
4	Discrepancy in words and figures	<p>(a) If, in the price structure quoted for the required goods/ Services/ works, there is discrepancy between the unit price and the total price (which is obtained by multiplying the unit price by the quantity), the unit price shall prevail and the total price corrected accordingly, unless in the opinion of the purchaser there is an obvious misplacement of the decimal point in the unit price, in which case the total price as quoted shall govern and the unit price corrected accordingly.</p> <p>(b) If there is an error in a total corresponding to the addition or subtraction of subtotals, the subtotals shall prevail and the total shall be corrected; and</p> <p>(c). If there is a discrepancy between words and figures, the amount in words shall prevail, unless</p>

		the amount expressed in words is related to an arithmetic error, in which case the amount in figures shall prevail subject of (a) and (b) above. (d) If there is such discrepancy in an offer, the same shall be conveyed to the bidder with target date upto which the bidder has to send his acceptance on the above lines and if the bidder does not agree to the decision of the purchaser, the bid is liable to be ignored.
5	Two Part bid clarifications	In the case of Two-part bid, the vendor should furnish technical and commercial clarifications, if any, within stipulated time mentioned, failing which, it will be construed that the vendor is not interested in the tender and BHEL shall not consider the offer for further evaluation.
6	Price Impacts	In the event of any bidder, after finalizing the technical specifications and scope of supply, opting to revise their original bid, they have to submit the Price-Impact only. The Original price bid along with Price-Impact bid shall be opened during price bid opening. Unsolicited price impacts will not be considered.
7	Price bid evaluation	All offers in price bid opening or reverse auction shall be evaluated in Indian currency based on unit price, packing & forwarding, taxes/duties, freight charges if any, exchange rate. Loading due to non-acceptance of our standard commercial terms will be evaluated as per the LOADING FACTORS form as enclosed along with the enquiry. The exchange rate declared by State Bank of India under TT Selling rate on the technical bid open date shall be adopted for evaluating foreign currency bids.
8	Packing	The supplier shall be responsible for the goods being properly and adequately packed so as to prevent any loss, damage or deterioration during transit.
9	Withdrawal	In case the supplier withdraws their offer before placement of order, BHEL reserves the right not to send next enquiry(ies). In case the supplier withdraws the quotation after its acceptance by BHEL or fails to supply the goods as per the terms and conditions of contract, or at any time repudiated the contract wholly or in part, BHEL shall be at liberty to cancel the Purchase Order and to recover from the supplier the extra cost and other loss, incidentals due to the breach of contract on the part of the supplier through risk purchase.
10	Risk Purchase	In case of default/late delivery, BHEL reserves the right to make alternate arrangement for procurement at suppliers risk and cost.
11	Banned List	The offers of the bidders who are in the banned list and the offers of the bidders who engage the services of the banned firms, shall be rejected. The list of banned firms is available on BHEL website <a href="http://www.bhel.com">www.bhel.com</a> . Guidelines for suspension of business dealings with suppliers/contractors are available on <a href="http://www.bhel.com">www.bhel.com</a> under supplier registration page
12	Over All L1	Order will be placed on overall L1 basis. Vendors should quote for all items, otherwise the offer will be rejected.
13	Additional Information	Suppliers are requested to visit our web site regularly for any updates and additional information, "All corrigenda, addenda, amendments, time extensions clarifications, etc. to the tender will be hosted on BHEL website only". The corrigendum will not be published in news paper.
14	Arbitration	Subject to the exclusive jurisdiction of the Medchal, Malkajgiri Courts, Telangana State, India, in respect of any suit or other legal proceedings relating to this contract.
15	Foreign Vendors	BHEL will deal directly with foreign vendors, where ever required, for procurement of goods. However, if the foreign principal desires to avail of services of an Indian agent, then foreign principal should ensure compliance to regulatory guidelines which require mandatory submission of agency agreement (as per *).  * The Agency Agreement shall specify 1) Agency commission, 2) Responsibilities of the agent, 3) Territory, 4) Agreement Period
16	Fraud Prevention Policy	The Bidder along with its associate/collaborators/sub-contractors/sub-vendors/consultants/service providers shall strictly adhere to BHEL Fraud Prevention Policy displayed on BHEL website <a href="http://www.bhel.com">http://www.bhel.com</a> and shall immediately bring to the notice of BHEL Management about any fraud or suspected fraud as soon as it comes to their notice.
17	Signing & Stamping	Documents of BHEL's all Terms and conditions submitted with the offer shall be signed and stamped in each page of authorized representative of the bidder

**Documents submitted with the offer shall be signed and stamped in each page of authorized representative of the bidder**

**Read and agreed for all the above general terms and conditions**

**Signature of the bidder with Seal & Date**

	<b>COMMERCIAL TERMS &amp; CONDITIONS (CTC)</b>	Volume - 1 Enquiry No 412101611
Machining & supply of DE mechanical components		

SL.No.	Clause	BHEL REQUIREMENT	SUPPLIERS ACCEPTANCE / REMARKS
1	Late Delivery Penalty Clause	Failure to supply the goods and/or Failure to carryout the services within the stipulated delivery date will attract a penalty of 0.5% per week or part thereof for the value of the undelivered portion of the purchase order subject to a maximum of 10% of the total order value. The Penalty amount determined based on the delay in supply/services along with applicable GST thereon shall be recovered. In case of non acceptance to this LD Clause, 10% of basic material cost will be loaded on the quoted prices while cost comparison.(Please refer the enclosed 'Loading Factors' sheet).	
2	Payment terms for Indian Offers	Vendor to indicate appropriate applicable HSN code for Goods as well as SAC for services based on Inter/Intra state.In case the bidder has opted for composite GST scheme,the same may be stated explicitly in both and techno-Commercial & Price bids. BHEL will pay only basic price to the vendor and release the GST payment only when the proof of remittance is given.	
3	Validity of Offer	90 days from date of techno-commercial bid opening.	
4	Price basis	The prices shall be firm for entire period of contract. The suppliers shall indicate packing and forwarding charges,if any, separately. All foreign suppliers shall quote the lowest prices on a) 'FOB-Nearest International Gateway Airport for Air consignments. BHEL shall organize shipment through our authorized freight forwarder from gateway Airport. An amount of 2% on basic value towards freight and 1% on basic value towards insurance will be added for cost comparison. b)CFR-Mumbai/Nhava sheva seaport for sea consignments. An amount of Insurance @1% (Supplier's seaport to BHEL R&D Stores, Hyderabad)+ local transport charges (Mumbai/Nhavasheva Seaport to BHEL R&D Stores, Hyderabad) based on weight/dimensions furnished by the supplier in the tender shall be added for landed cost evaluation. All Indian suppliers shall quote the lowest prices on 'free delivery at BHEL R&D Stores or F.O.R destination' basis only.	
5	Rate Contract	In case the goods enquired are on Rate Contract basis with any other unit of BHEL, such fact should be clearly indicated in the quotation giving full particulars of Rate Contract number, validity and price and also your willingness to comply with order if placed against such Rate Contract. A copy of Rate contract signed by the supplier should be sent with the quotation.	
6	Freight & Insurance	Insurance will be arranged by BHEL in case of FOB basis supplies. In such cases ,an amount of 3% towards freight and insurance will be added for cost comparison.	
7	Agency Agreement	Guidelines regarding dealing with Indian agents of foreign suppliers 1. BHEL shall deal directly with foreign vendors, wherever required, for procurement of goods. However, if the foreign principal desires to avail of services of an Indian agent, then the foreign principal should ensure compliance to regulatory guidelines which require mandatory submission of agency agreement. 2. It shall be incumbent on the Indian agent and the foreign principal to adhere to the relevant guidelines of government of India, issued from time to time. 3. The agency agreement should specify the precise relationship between the foreign OEM and services to be rendered by Indian agent / associate, whether general in nature or in relation to the particular contract, must clearly be stated by the foreign supplier / Indian Agent. Any payment, which the Indian agent / associate receives in India or abroad from the OEM, whether as commission or as a general retainer fee shall be brought out in record in the agreement and be made explicit in order to ensure compliance to the laws of the country. 4. Any agency commission to be paid by BHEL to the Indian agent shall be Indian currency. 5. When ever Indian agents are representing on behalf of their principals, the relevant authorization letter and agreement copy to be enclosed along with technical bid to consider the offer.	
		FOR INDIAN SUPPLIES : ===== Suppliers are requested to quote within the delivery date mentioned in the enquiry. They shall also mention one of the following delivery periods compulsorily.  1) Delivery Period from date of Purchase order =====  2) Delivery Period from receipt of material / input data / drawings etc. from BHEL===== (if applicable)  3) Delivery Period from receipt of approval of design documents / drawings etc. by BHEL===== (if applicable)  However BHEL shall inform the vendor about rejection of the offer before price bid opening in case of not meeting the delivery requirements of BHEL.	

8	Delivery Period	<p><u>FOR FOREIGN SUPPLIES :</u></p> <p>Suppliers are requested to quote within the delivery date mentioned in the enquiry. They shall also mention one of the following delivery periods compulsorily.</p> <p>1. Delivery Period from date of Purchase order :=====</p> <p>2. Delivery Period from receipt of input data / drawings etc. from BHEL =====</p> <p>(if applicable)</p> <p>3. Delivery Period from receipt of approval of design documents / drawings etc. by BHEL =====</p> <p>( if applicable )</p> <p>4. Delivery Period from date of LC Opening =====</p> <p>( if applicable)</p> <p>5. Delivery Period from date of PO acceptance =====</p> <p>However BHEL shall inform the vendor about rejection of the offer before price bid opening in case of not meeting the delivery requirements of BHEL.</p> <p>Pl. mention any other issues/constraints like export clearance etc. explicitly, if any =====</p>	
9	Nature of Vendor submitting the Offer	OEM / Agent / Representative / Dealer / Distributor / Stockist / Trader / Reseller / Channel Partner/ System Integrator / Any Other (Pl. Specify)	
10	Foreign Suppliers without Indian Agent	To be quoted in Foreign Currency. Purchase Order will be placed on Foreign Supplier.	
11	Foreign Principal availing services of an Indian Agent	<p>Foreign principal should ensure compliance to regulatory guidelines which require mandatory submission of Agency agreement. (as per *)</p> <p>To be quoted in Foreign Currency.</p> <p>Purchase order will be placed on Foreign Supplier. Agency Commission will be paid to Indian Agent in Indian rupees.</p> <p>* The Agency Agreement shall specify 1) Agency commission, 2) Responsibilities of the Agent, 3) Territory, 4) Agreement Period</p>	
12	Indian Agent desirous of quoting imported Equipment	<p>Any Indian Agent desirous of quoting imported Equipment, they should submit the quote in foreign currency along with copy of agency agreement (as per *).</p> <p>To be quoted in Foreign Currency.</p> <p>Purchase order will be placed on Foreign Supplier. Agency Commission will be paid to Indian Agent in Indian rupees.</p> <p>* The Agency Agreement shall specify 1) Agency commission, 2) Responsibilities of the agent, 3) Territory, 4) Agreement Period</p>	
13	Payment terms for Foreign Offers (Supply )	<p>BHEL standard payment term</p> <p>"100% Invoice value by wire transfer within 30 days of receipt and acceptance of material at BHEL R&amp;D Stores, Hyderabad".</p> <p>All bank charges inside India shall be to BHEL account and outside India shall be to supplier's account.</p> <p>Note:For other payment terms there will be a loading on the offer as mentioned in our 'Loading Factors" sheet which is enclosed to this enquiry.</p>	

**Note :** All the clauses of the above format should be filled and submitted with the Techno Commercial Bid (Part-1). The filled in BHEL Commercial terms & Conditions format submitted with technical bid, responding to all the clauses duly signed with seal **only shall be considered**. Any other Commercial terms & conditions of bidders entered else where in their offer shall not be considered and are liable for rejection.

**Signature of the bidder with Seal & Date**



## OTHER TERMS &amp; CONDITIONS

Volume - 1  
Enquiry No  
412101611

Machining &amp; supply of DE mechanical components

SL.No.	Clause	BHEL REQUIREMENT	SUPPLIERS ACCEPTANCE / REMARKS
1	Packing & forwarding charges, freight and insurance charges, if any	Mention the packing & forwarding, freight & insurance, if any, in terms of percentage(%)of basic cost.	
2	Regarding Concessional Taxes/Duties	Concessional duties/taxes, if any, available to BHEL at price bid opening shall be taken into account for evaluating landed cost calculation. Hence suppliers are requested to submit their bids clearly stating applicable taxes/duties. However, all suppliers have to accept Concessional duties in case if the same is available to BHEL at dispatch	
3	Details required	IT Permanent Account No. (PAN): GSTIN Registration Status: Tax type: CGST/SGST/IGST/UGST GSTIN No: GSTIN No. Issuance Date : Provisional/ Final Registration : Name of the Contact Person : Contact Phone / Mobile : Email id for correspondence : Address with PIN code and State: HSN code, service account code	
4	Force Majeure	If at any time during the continuance of the contract the performance in whole or in part by either party of any obligations under the contract is prevented or delayed by reason, of any war, hostilities, acts of the public enemy, civil commotion, sabotage, fires, explosions, epidemics, quarantine, restrictions or acts of GOD (hereinafter referred to as events) and notice of happening of any such events is given by either party to other within twenty one days from the date of occurrence thereof then neither party shall by reason of such events be entitled to terminate the contract. If the performance in whole or part of any obligation under this contract is prevented or delayed by reason of occurrence of such events, then claims for extension of time shall be granted for period considered reasonable by the purchaser subject to prompt notification by the seller to the purchaser the particulars of the events, if required with supporting evidence. Any waiver of time in respect of partial installment shall not be deemed to be a waiver of time in respect of remaining deliveries	
5	Firm Price	The prices shall be firm for entire period of contract.	
6	Price Basis	Bidders shall quote the lowest prices on 'free delivery at BHEL R&D Stores or F.O.R destination' basis only.	
7	Applicable Taxes/Duties	Please indicate the applicable Taxes/Duties in the offer clearly.	
8	General terms	1) Submission of GST Registration details along offer is required for consideration of the Offer. 2) Kindly provide the HSN code and the breakup of the tariff/taxes (CGST/SGST/IGST/UGST) based on from and to locations with individual components. 3) Concessional taxes/duties, if any, available to BHEL as on date of price bid opening shall be taken into account for evaluating landed cost. 4)Hence all offers shall be evaluated at available concessional rates of, if any, on or before opening of price bid date or otherwise it shall be evaluated with quoted/prevaling rates as on date of price bid opening for landed cost comparison. However, all suppliers have to accept Concessional taxes/duties in case if the same is available to BHEL as on date of dispatch. 5) Taxes and duties to be governed by GST acts. Strict adherence to new provisions by the vendors like timely submission of invoices, tax payment, filing of returns-GSTR-I etc. will form base of new regime for release of payment from BHEL. Hence, any financial loss occurred due to noncompliance of the GST provisions would be endured at defaulters end.	

9	Payment terms	100% of Basic Value will be paid by EFT/RTGS within 30 days of receipt and acceptance of material at BHEL R&D Stores, Hyderabad. Taxes will be reimbursed against submission of proof of remittance of Taxes to govt. of India. Note:For other payment terms there will be a loading on the offer as mentioned in our 'Loading Factors" sheet which is enclosed to this enquiry.	
10	Price Bid Evaluation	All offers in price bid opening or reverse auction shall be evaluated in Indian currency based on unit price, packing & forwarding, taxes/duties, freight charges if any. Loading due to non-acceptance of our standard commercial terms will be evaluated as per the LOADING FACTORS form as enclosed along with the enquiry	
11	Destination	Indian Vendors: Destination shall be Stores,BHEL R&D, Vikasnagar, Hyderabad-500093. Foreign Vendors:Destination Shall be CIF Hyderabad Airport,India	
13	Annexure -I	Details of 1 set of DE components(BoM) is enclosed as annexure-I	
14	Annexure -II	Restrictions on Procurement from a bidder of a country which shares a land border with India:	

**Signature of the bidder with Seal & Date**

	<b>ITEM SPECIFICATIONS</b>	Volume - 2 Enquiry NO 412101611
Machining & supply of DE mechanical components		

SL.No.	Item		
1	<b>Machining and supply of DE mechanical components</b>		
sl no	Descriptions	BHEL Specifications	Vendor Specifications/ Deviations
1	Material certification	Material composition report either obtained from source or determined from component to be provided along with supply.	
2	Drawings	Tentative drawings are enclosed with the tender. Final drawings shall be provided along with PO. Final dimensions may vary by upto 5%.	
3	Warranty	Supplier shall comply to the minimum acceptable warranty period. The minimum acceptable warranty period is 12 months from the date of material receipt & acceptance at BHEL R&D	
4	Dimensional accuracy	Components are for a high precision application. Hence, dimensional accuracy to be strictly adhered.	
5	Surface finish	Average surface roughness (Ra) 3.2 micrometers to be maintained on all surfaces	

\* Vendors are advised to write specifications in detail and not to write like 'Complied/ Yes / No ' etc. in specifications.

**Signature of the bidder with Seal & Date**

**LOADING FACTORS**



**NOTE : IN CASE OF DEVIATION TO BHEL TENDER SPECIFIED TERMS, LOADING FACTOR INDICATED IN FOLLOWING TABLE WILL BE APPLIED TO QUOTED PRICE WHILE EVALUATING THE LOWEST QUOTE**

A. FOR INDIGENOUS PURCHASES					
SLNO	SCOPE	COMMERCIAL TERMS	BHEL STANDARD TERM	AS OFFERED	LOADING FACTOR FOR NON COMPLIANCE TO BHEL STANDARD TERMS
A.1	SUPPLY OF EQUIPMENT	PAYMENT TERMS	100% PAYMENT, WITH IN 30 DAYS FROM THE DATE OF RECEIPT AND ACCEPTANCE OF MATERIAL AT BHEL R&D	SAME	NIL
				PAYMENT AGAINST PROFORMA INVOICE / DESPATCH DOCUMENTS	LOADING @ (SBI BASE RATE ON TENDER OPENING DATE+ 6%) ON THE TOTAL PO VALUE FOR ONE MONTH
				INTEREST BEARING PART ADVANCE (MAXIMUM 5% @SBI BASE RATE ON TENDER OPENING DATE+ 6%) PAYMENT WITH 110% BANK GUARANTEE AND BALANCE PAYMENT WITH IN 30 DAYS FROM THE DATE OF RECEIPT AND ACCEPTANCE OF THE MATERIAL	LOADING @ (SBI BASE RATE ON TENDER OPENING DATE+ 6%) ON PART ADVANCE AMOUNT (X%) FOR THE DELIVERY PERIOD ( Rounded off to nearest month) + 1 MONTH
				INTEREST BEARING PART ADVANCE (MAXIMUM 5% @SBI BASE RATE ON TENDER OPENING DATE+ 6%) PAYMENT WITH 110% BANK GUARANTEE AND BALANCE PAYMENT ON RECEIPT AND ACCEPTANCE OF MATERIAL	LOADING @ (SBI BASE RATE ON TENDER OPENING DATE+ 6%) ON PART ADVANCE AMOUNT (X%) FOR THE DELIVERY PERIOD (Rounded off to nearest month) + 1 MONTH AND LOADING @ (SBI BASE RATE ON TENDER OPENING DATE+ 6%) ON BALANCE AMOUNT FOR ONE MONTH
A.2	SUPPLY OF EQUIPMENT INCLUDING ERECTION AND COMMISSIONING (E&C)	PAYMENT TERMS	90% PAYMENT, WITH IN 30 DAYS FROM THE DATE OF RECEIPT AND ACCEPTANCE OF MATERIAL AND BALANCE 10% WITH IN 30 DAYS OF COMPLETION OF E&C.	SAME	NIL
				100% PAYMENT WITH IN 30 DAYS AFTER COMPLETION OF SUPPLIES AND E&C	NIL
				90% PAYMENT AGAINST PROFORMA INVOICE/ DESPATCH DOCUMENT AND BALANCE 10% WITH IN 30 DAYS AFTER COMPLETION OF E&C.	LOADING @ (SBI BASE RATE ON TENDER OPENING DATE+ 6%) ON 90% OF THE VALUE OF PO FOR ONE MONTH
				90% PAYMENT AGAINST PROFORMA / DESPATCH DOCUMENT AND BALANCE 10% AFTER COMPLETION OF E&C	LOADING @ (SBI BASE RATE ON TENDER OPENING DATE+ 6%) ON TOTAL VALUE OF THE PO FOR ONE MONTH
				INTEREST BEARING PART ADVANCE (MAXIMUM 5% @SBI BASE RATE ON TENDER OPENING DATE+ 6%) PAYMENT WITH 110% BANK GUARANTEE AND (90 - X) % PAYMENT ON RECEIPT AND ACCEPTANCE OF THE MATERIAL AND 10% PAYMENT WITH IN 30 DAYS AFTER COMPLETION OF E&C	LOADING @ (SBI BASE RATE ON TENDER OPENING DATE+ 6%) ON THE PART ADVANCE AMOUNT (X%) FOR THE DELIVERY PERIOD (ROUNDED OFF TO THE NEAREST MONTH) + 1 MONTH AND LOADING @ (SBI BASE RATE ON TENDER OPENING DATE+ 6%) ON BALANCE (90-X)% AMOUNT FOR ONE MONTH
				INTEREST BEARING PART ADVANCE (MAXIMUM 5% @SBI BASE RATE ON TENDER OPENING DATE+ 6%) PAYMENT WITH 110% BANK GUARANTEE AND BALANCE (90 - X) % PAYMENT AFTER RECEIPT AND ACCEPTANCE OF THE MATERIAL AND 10% PAYMENT AFTER COMPLETION OF E&C	LOADING @ (SBI BASE RATE ON TENDER OPENING DATE+ 6%) ON THE PART ADVANCE AMOUNT (X%) FOR THE DELIVERY PERIOD (ROUNDED OFF TO THE NEAREST MONTH) + 1 MONTH AND LOADING @ (SBI BASE RATE ON TENDER OPENING DATE+ 6%) ON BALANCE AMOUNT (100-X)% FOR ONE MONTH

B. FOR FOREIGN PURCHASES (IMPORTED)					
SL.NO	SCOPE	COMMERCIAL TERMS	BHEL STANDARD TERM	AS OFFERED	LOADING FACTOR FOR NON COMPLIANCE TO BHEL STANDARD TERMS
B.1	SUPPLY OF EQUIPMENT	PAYMENT TERMS	100% PAYMENT BY WIRE TRANSFER WITHIN 30 DAYS FROM THE DATE OF RECEIPT AND ACCEPTANCE OF MATERIAL AT BHEL R&D. (DESPATCH DOCUMENTS WILL BE SENT TO BHEL R&D DIRECTLY ALONG WITH BANK DETAILS)	SAME	NIL
				SIGHT DRAFT ON PRESENTATION OF DESPATCH DOCUMENTS VIZ INVOICE, AWB ETC TO OUR BANKERS	LOADING @ (SBI BASE RATE ON TENDER OPENING DATE+6%) ON THE BASIC VALUE FOR ONE MONTH PLUS PAYMENT RELATED BANK CHARGES INCURRED BY BHEL
				LC PAYMENT AGAINST DESPATCH DOCUMENTS	LOADING @ (SBI BASE RATE ON TENDER OPENING DATE+ 6%) ON THE BASIC VALUE FOR ONE MONTH PLUS LC RELATED BANK CHARGES INCURRED BY BHEL
				INTEREST BEARING PART ADVANCE (MAXIMUM 5% @SBI BASE RATE ON TENDER OPENING DATE+ 6%) PAYMENT WITH 110% BANK GUARANTEE BY WIRE TRANSFER/LC AND BALANCE PAYMENT WITH IN 30 DAYS FROM THE DATE OF RECEIPT AND ACCEPTANCE OF THE MATERIAL	LOADING @ (SBI BASE RATE ON TENDER OPENING DATE+ 6%) ON THE PART ADVANCE AMOUNT (X%) FOR THE DELIVERY (ROUNDED OFF TO NEAREST MONTH) + 1 MONTH PLUS LC RELATED BANK CHARGES INCURRED BY BHEL
B.2	SUPPLY OF EQUIPMENT INCLUDING ERECTION AND COMMISSIONING ( E&C )	PAYMENT TERMS	90% PAYMENT BY WIRE TRANSFER WITH IN 30 DAYS FROM THE DATE OF RECEIPT AND ACCEPTANCE OF THE MATERIAL AND BALANCE 10% WITH IN 30 DAYS AFTER COMPLETION OF E&C	SAME	NIL
				SIGHT DRAFT ON PRESENTATION OF DESPATCH DOCUMENTS VIZ INVOICE, AWB ETC TO OUR BANKERS	LOADING @ (SBI BASE RATE ON TENDER OPENING DATE+6%) FOR ONE MONTH PLUS PAYMENT RELATED BANK CHARGES INCURRED BY BHEL
				90 PAYMENT BY WIRE TRANSFER /LC AGAINST DESPATCH DOCUMENTS BALANCE 10% WITH IN 30 DAYS AFTER COMPLETION OF E&C	LOADING @ (SBI BASE RATE ON TENDER OPENING DATE+6%) ON 90% OF BASIC VALUE FOR ONE MONTH PLUS LC RELATED BANK CHARGES INCURRED BY BHEL
				90% PAYMENT BY WIRE TRANSFER / LC AGAINST DESPATCH DOCUMENTS. BALANCE 10% AFTER COMPLETION OF E&C	LOADING @ (SBI BASE RATE ON TENDER OPENING DATE+6%) ON THE BASIC VALUE FOR ONE MONTH PLUS LC RELATED BANK CHARGES INCURRED BY BHEL
B.2	SUPPLY OF EQUIPMENT INCLUDING ERECTION AND COMMISSIONING ( E&C )	PAYMENT TERMS	90% PAYMENT BY WIRE TRANSFER WITH IN 30 DAYS FROM THE DATE OF RECEIPT AND ACCEPTANCE OF THE MATERIAL AND BALANCE 10% WITH IN 30 DAYS AFTER COMPLETION OF E&C	90% OF BASIC VALUE AS ADVANCE PAYMENT BY WIRE TRANSFER /LC WITH BANK GUARTEE AND BALANCE 10% WITH IN 30 DAYS AFTER COMPLETION OF E&C	LOADING @ (SBI BASE RATE ON TENDER OPENING DATE+6%) ON THE BASIC VALUE FOR ONE MONTH PLUS LC RELATED BANK CHARGES INCURRED BY BHEL
				INTEREST BEARING PART ADVANCE (MAXIMUM 5% @SBI BASE RATE ON TENDER OPENING DATE+ 6%) PAYMENT WITH 110% BANK GUARANTEE BY WIRE TRANSFER/LC AND BALANCE 10% WITH IN 30 DAYS AFTER COMPLETION OF E&C	LOADING @ (SBI BASE RATE ON TENDER OPENING DATE+6%) ON 90% OF THE BASIC VALUE FOR DELIVERY PERIOD (ROUNDED OFF TO NEAREST MONTH) + ONE MONTH PLUS LC RELATED BANK CHARGES INCURRED BY BHEL
				INTEREST BEARING PART ADVANCE (MAXIMUM 5% @SBI BASE RATE ON TENDER OPENING DATE+ 6%) PAYMENT WITH 110% BANK GUARANTEE BY WIRE TRANSFER/LC AND BALANCE (90-X)% PAYMENT BY WIRE TRANSFER /LC AFTER RECEIPT AND ACCEPTANCE OF THE MATERIAL AND 10% PAYMENT WITH IN 30 DAYS AFTER COMPLETION OF E&C	LOADING @ (SBI BASE RATE ON TENDER OPENING DATE+ 6%) ON THE PART ADVANCE AMOUNT (X%) FOR THE DELIVERY PERIOD (ROUNDED OFF TO NEAREST MONTH) + ONE MONTH AND LOADING @ (SBI BASE RATE ON TENDER OPENING DATE+ 6%) ON BALANCE (90-X)% FOR ONE MONTH
				INTEREST BEARING PART ADVANCE (MAXIMUM 5% @SBI BASE RATE ON TENDER OPENING DATE+ 6%) PAYMENT WITH 110% BANK GUARANTEE BY WIRE TRANSFER/LC AND BALANCE (90-X)% PAYMENT BY WIRE TRANSFER /LC AFTER RECEIPT AND ACCEPTANCE OF THE MATERIAL AND 10% PAYMENT AFTER COMPLETION OF E&C	LOADING @ (SBI BASE RATE ON TENDER OPENING DATE+ 6%) ON THE PART ADVANCE AMOUNT (X%) FOR THE DELIVERY PERIOD (ROUNDED OFF TO NEAREST MONTH) + ONE MONTH AND LOADING @ (SBI BASE RATE ON TENDER OPENING DATE+ 6%) ON BALANCE AMOUNT (100-X)% FOR ONE MONTH
C. PENALTY FOR DELAYED DELIVERY (COMMON FOR INDIGENOUS AND IMPORTS)					
SL.NO	COMMERCIAL TERMS	BHEL STANDARD TERM	AS OFFERED	LOADING FACTOR FOR NON COMPLIANCE TO BHEL STANDARD TERMS	
C	LD CLAUSE	IN THE EVENT OF DELAY IN AGREED CONTRACTUAL DELIVERY, PENALTY OF 0.5% ( HALF PERCENT ) PER WEEK BUT LIMITED TO A MAX OF 10% OF TOTAL ORDER VALUE WILL BE APPLICABLE	AGREED	NIL	
			IF NOT AGREED	LOADING @ 10% OF THE BASIC MATERIAL COST	
			IF AGREED FOR X%	LOADING @ ( 10-X)% OF THE BASIC MATERIAL COST	
D. GUARANTEE/WARRANTY PERIOD (COMMON FOR INDIGENOUS AND IMPORTS)					
SL.NO	COMMERCIAL TERMS	BHEL STANDARD TERM	AS OFFERED	LOADING FACTOR FOR NON COMPLIANCE TO BHEL STANDARD TERMS	
D	GUARANTEE/WARRANTY PERIOD	STIPULATED OR REQUIRED GUARANTEE/WARRANTY PERIOD(X)	AGREED	NIL	
		MINIMUM ACCEPTABLE GUARANTEE / WARRANTY PERIOD(Y)	NOT AGREED FOR STIPULATED BUT AGREED FOR MINIMUM GUARANTEE/WARRANTY(Y)	LOADING @ 10 % OF THE ORDER VALUE PER ANNUM FOR THE REDUCED GUARANTEE PERIOD (X-Y)	

## Terms & Conditions of Reverse Auction



Against this enquiry for the subject item/ system with detailed scope of supply as per enquiry specifications, BHEL may resort to "REVERSE AUCTION PROCEDURE" i.e., ON LINE BIDDING (THROUGH A SERVICE PROVIDER). The philosophy followed for reverse auction shall be English Reverse (No ties).

1. For the proposed reverse auction, technically and commercially acceptable bidders only shall be eligible to participate.
2. Those bidders who have given their acceptance for Reverse Auction (quoted against this tender enquiry) will have to necessarily submit online sealed bid in the Reverse Auction. Non-submission of online sealed bid by the bidder for any of the eligible items for which techno-commercially qualified, will be considered as tampering of the tender process and will invite action by BHEL as per extant guidelines in vogue.
3. BHEL will engage the services of a service provider who will provide all necessary training and assistance before commencement of on line bidding on internet.
4. In case of reverse auction, BHEL will inform the bidders the details of Service Provider to enable them to contact & get trained.
5. Business rules like event date, time, bid decrement, extension etc. also will be communicated through service provider for compliance.
6. Bidders have to fax the Compliance form (annexure IV) before start of Reverse auction. Without this, the bidder will not be eligible to participate in the event.
7. In line with the NIT terms, BHEL will provide the calculation sheet (e.g. EXCEL sheet) which will help to arrive at "Total Cost to BHEL" like Packing & forwarding charges, Taxes and Duties, Freight charges, Insurance, Service Tax for Services and loading factors (for non-compliance to BHEL standard Commercial terms & conditions) for each of the bidder to enable them to fill-in the price and keep it ready for keying in during the Auction.
8. Reverse auction will be conducted on scheduled date & time.
9. At the end of Reverse Auction event, the lowest bidder value will be known on auction portal.
10. The lowest bidder has to fax/e-mail the duly signed and filled-in prescribed format for price breakup including that of line items, if required, (Annexure VII) as provided on case-to-case basis to Service provider within two working days of Auction without fail.
11. In case BHEL decides not to go for Reverse Auction procedure for this tender enquiry, the Price bids and price impacts, if any, already submitted and available with BHEL shall be opened as per BHEL standard practice.
12. Bidders shall be required to read the "Terms and Conditions" section of the auctions site of Service provider, using the Login IDs and passwords given to them by the service provider before reverse auction event. Bidders should acquaint themselves of the „Business Rules of Reverse Auction?, which will be communicated before the Reverse Auction.
13. If the Bidder or any of his representatives are found to be involved in Price manipulation/ cartel formation of any kind, directly or indirectly by communicating with other bidders, action as per extant BHEL guidelines, shall be initiated by BHEL and the results of the RA scrapped/ aborted.
14. The Bidder shall not divulge either his Bids or any other exclusive details of BHEL to any other party.
15. In case BHEL decides to go for reverse auction, the H1 bidder (whose quote is highest in online sealed bid) may not be allowed to participate in further RA process.

**AUTHORISATION LETTER FOR E-PAYMENT/ NEFT / RTGS**  
(PLEASE FILL UP THE FORM COMPLETELY IN CAPITAL LETTERS ON YOUR COMPANY LETTERHEAD ONLY)

Vendor Code (to be filled by BHEL)	
------------------------------------	--

Type of Request (Tick one)	NEW	CHANGE
1 Company Name		
2 Address		
3 City with PIN Code		
4 State		
5 PAN Number		
6 TIN/ VAT No.		
7 CST No.		
8 Service Tax No.		
9 Name of Contact Person		
10 Mobile number		
11 Ph. no. with STD Code		
12 Fax No. with STD Code		
13 Email ID		
14 Website (URL)		

**BANK DETAILS FOR EFT / RTGS**

1	Bank Name	
2	Branch	
3	Branch Code	
4	Branch Address	
5	Branch Phone No	
6	Account No.	
7	Account Type: SB/ Current/ other (Specify)	
8	MICR Code	
9	IFSC Code	

I, as an authorized representative / owner of the above named company, hereby state as under:

1. Enclosed here with a cancelled cheque in support of our company's bank details.
2. Authorize BHEL R&D Hyderabad, to electronically make payments to the designated bank account with bank charges, if any, to our account.
3. If the transaction is delayed or not effected at all for reasons of incomplete or incorrect information, I would not hold BHEL / transferring Bank responsible.
4. I hereby certify that the particulars given above are true, complete and correct.
5. This authority remains in full force until BHEL receives and acknowledge written notification requesting change or cancellation.

Date :  
Company  
Seal

Authorised Signatory  
Designation :



RD:MPX:F-13

## Bharat Heavy Electricals Limited

Corp. R&D DIVISION

VIKAS NAGAR,

HYDERABAD- 500 093 (INDIA)

### VENDOR REGISTRATION FORM

(Indigenous supplier)

[FORM TO BE SUBMITTED\* BY THE BIDDER ALONG WITH TECHNICAL-BID]

Before filling, please refer to instructions on page-4

#### 1.0 VENDOR PROFILE:

1.1 Name and address of the vendor:

\_\_\_\_\_

\_\_\_\_\_

\_\_\_\_\_

Phone Nos.:

Fax No.:

Email: 1.

2.

1.2 Local representative name & address in Hyderabad/Secundrabad :

\_\_\_\_\_

\_\_\_\_\_

\_\_\_\_\_

Phone Nos.:

Fax No.:

Email:

Contact Person:

Mobile No:

#### 2.0 TYPE OF ORGANISATION:

PROPRIETORSHIP	Company:	Sister Concern ( mention vendor registration number of main organization)	
Partnership	CORPORATION	Small Scale Industry	ANY OTHER(Please specify)

In case of SSI unit, copy of registration to be enclosed. It is requested that MSME registration certificate to be enclosed and tick the following:

Type of Major Activity: Manufacturing / Service

Category of Enterprise: Micro / Small / Medium

Social Category : GENERAL / SC / ST / OBC

Udyog Adhaar Number (UAN): \_\_\_\_\_

#### 3.0 ANNUAL TURN OVER:

#	Year	Turn-Over, Rs.
1	Current Year(budgeted)	
2	Previous year ( 200 - 0 )	
3	Prior Year ( 200 - 0 )	

#### 4.0 NAME AND ADDRESS OF THE BANKER:

4.1 Bank Name

4.2 Branch name

4.3 Account number

4.4 Account Type

4.5 MICR Code:

4.6 IFSC Code(RTGS/NEFT):

4.7 Bank Phone number(s),

Blank cheque, duly cancelled, to be enclosed.

Please note that all payments shall be made through Electronic clearance services to your above account against the orders executed, if any.

**5.0 REGISTRATION PARTICULARS**(relevant copies to be enclosed)

5.1 IT Permanent Account No.(PAN):

5.2 State Sales Tax/VAT Registration No:

5.3 Central Sales Tax Registration No:

5.4 ED Registration No:

5.5 Service Tax Registration No:

5.6 PF Account No:

5.7 Labour Licence No:

5.8 ESI Account No:

**6.0 CONTACT PERSON:** S/Sri:

Designation:

Phone / Mobile No:

**7.0 TOTAL NUMBER OF EMPLOYEES:**

Graduates(Engr/Scientists/Mgmt/Fin.)	Consultants	Workers		
		Sup./Skilled	Semiskilled	Unskilled

**8.0 LIST OF PRODUCTS/ SERVICES OFFERED:**

#	Products/ Services	Capacity
1		
2		
3		
4		
5		

**9.0 REFERENCE LIST :**

(Only recognized public and private sector companies, attach if printed copy available)

#	Customer	Volume / Year
1		
2		
3		
4		
5		

**10.0 INFRASTRUCTURE / FACILITIES:**

#	Facility (with specifications)	Age/ Year procured
1		
2		
3		
4		
5		

**11.0 REGISTRATION WITH OTHER BHEL UNIT/UNITS:**

#	Unit	Registration No	Year
1			
2			
3			
4			

**12.0 ANY OTHER INFORMATION :**

**DECLARATION:**

The information furnished above is true and authentic.

(CEO / PROPRIETOR)

SEAL:

**DATE:**

Note:

- 
1. Registered bidders, having BHEL (R&D) registration no. or have submitted this format for registration, need not furnish this information again.
  2. The competent authority reserves the right to accept or reject the registration.
  3. Vendors approved for registration will be informed by mail / email, as convenient. A separate communication will be sent in case of non-registration also, citing reasons thereof.
  4. BHEL reserves the right to take penal action as deemed fit if any of the information provided by the vendor(s) is found to be incorrect.
  5. AGM, Head (MM) may be contacted for clarification/additional information on registration.

Instructions

- 
1. Fill all items. Please mention "N.A." for items/ clauses not applicable.
  2. Use A4 sheets for this document and the enclosures. Use of additional sheets is permitted if space provided is not adequate.
  3. Attach copies of latest documents in respect of items 5.0 (Registration no.s)
  4. Photographs of registered office and the chief executive/proprietor shall be furnished.



RD:MPX:F-14

## Bharat Heavy Electricals Limited

Corp. R&amp;D DIVISION

VIKAS NAGAR,

HYDERABAD- 500 093 (INDIA)

### SUPPLIER REGISTRATION FORM

(FOREIGN SUPPLIER)

ALL COLUMNS SHOULD BE PROPERLY FILLED IN THE SPACE PROVIDED FOR.WHEREVER IT IS NOT APPLICABLE PLEASE WRITE "NOT APPLICABLE".INCOMPLETE OR INCORRECT FORMS MAY NOT BE CONSIDERED.

#### 1.0 GENERAL INFORMATION:

1.1 NAME OF COMPANY

1.2 DETAILS OF HEAD OFFICE:

ADDRESS :  
 TELEPHONE :  
 FAX :  
 EMAIL :  
 WEB SITE :

1.3 DETAILS OF FACTORY/WORKS:

ADDRESS :  
 TELEPHONE :  
 FAX :  
 EMAIL :  
 WEB SITE :

1.4 DETAILS OF MARKETING AGENT

ADDRESS :  
 TELEPHONE :  
 FAX :  
 EMAIL :  
 WEB SITE :

1.5 CHIEF EXECUTIVE

1.6 CONTACT PERSON(S)

FOR PRODUCT OFFERED

NAME(S) :  
 OFFICIAL CPACITY :  
 ADDRESS :  
 TELEPHONE :  
 FAX :  
 EMAIL :

1.7 YEAR OF ESTABLISHMENT

1.8 PRODUCTION CAPACITY PER ANNUM

1.9 PARTICULARS OF PRODUCT INCLUDING  
 SPECIFICATION AND RANGE OFFERED  
 FOR REGISTRTRION  
 (Attach brochures and catalogues)

1.10 NAME(S) OF BANKERS

1.11 BANKER'S CERTIFICATE

1.12 PORT OF LOADING





RD:MPX:F-13

## **Bharat Heavy Electricals Limited**

**Corp. R&D DIVISION**

**VIKAS NAGAR,**

**HYDERABAD- 500 093 (INDIA)**

**Ph: 040 – 23772704, Fax: 040 – 23770698, email: mpx@bhelrnd.co.in**

---

### **GUIDE LINES REGARDING DEALINGS WITH INDIAN AGENTS OF FOREIGN SUPPLIERS**

- i. BHEL shall deal directly with foreign vendors, wherever required, for procurement of goods. However, if the foreign principal desires to avail of the services of an Indian agent, then the foreign principal should ensure compliance to regulatory guidelines - which require mandatory submission of an Agency Agreement.
- ii. It shall be incumbent on the Indian agent and the foreign principal to adhere to the relevant guidelines of Government of India, issued from time to time.
- iii. The Agency Agreement should specify the precise relationship between the foreign OEM / foreign principal and their Indian agent and their mutual interest in the business. All services to be rendered by agent/ associate, whether of general nature or in relation to the particular contract, must be clearly stated by the foreign supplier/ Indian agent. Any payment, which the agent or associate receives in India or abroad from the OEM, whether as commission or as a general retainer fee should be brought on record in the Agreement and be made explicit in order to ensure compliance to laws of the country.
- iv. Any agency commission to be paid by BHEL to the Indian agent shall be in Indian currency only.
- v. Whenever Indian agents are representing on behalf of their principals the relevant authorisation letter and agreement copy to be enclosed along with Technical bid to consider the offer.



Annexure- 1

**Ref : Indent no. 41210161**

1 set of DE components consists of following components as mentioned in the table below:

<b>S. No</b>	<b>Title</b>	<b>Drawing No</b>	<b>Quantity</b>
1	DE EPS	FS - DE - 2021 - 04	1
2	DE Flange	FS - DE - 2021 - 07	1
3	DE IPS	FS - DE - 2021 - 03	1
4	DE SRH	FS - DE - 2021 - 06	1
5	DE SS	FS - DE - 2021 - 01	1



INVENTORY NO. REF. DRG. NO. COMP. FILE NAME THE INFORMATION ON THIS DOCUMENT IS THE PROPERTY OF BHARAT HEAVY ELECTRICALS LIMITED. IT MUST NOT BE USED DIRECTLY OR INDIRECTLY IN ANY WAY DETRIMENTAL TO THE INTEREST OF THE COMPANY.

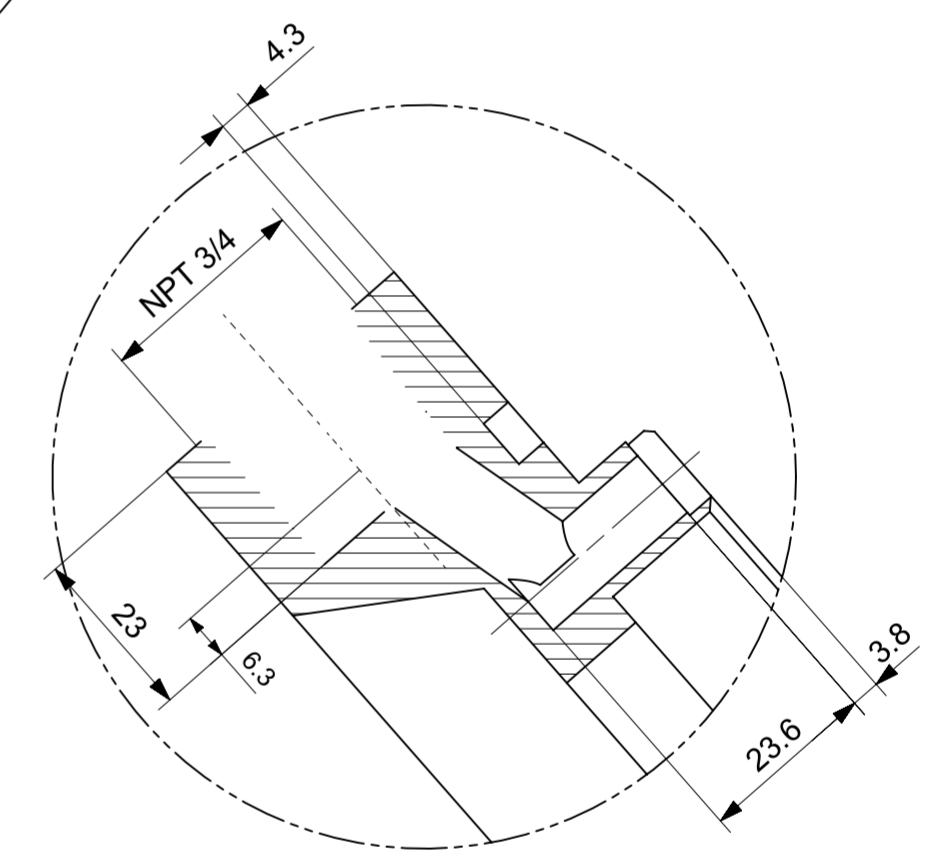
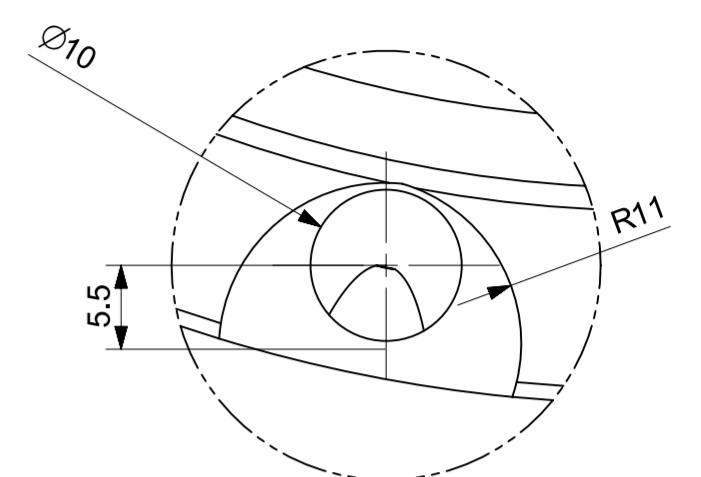
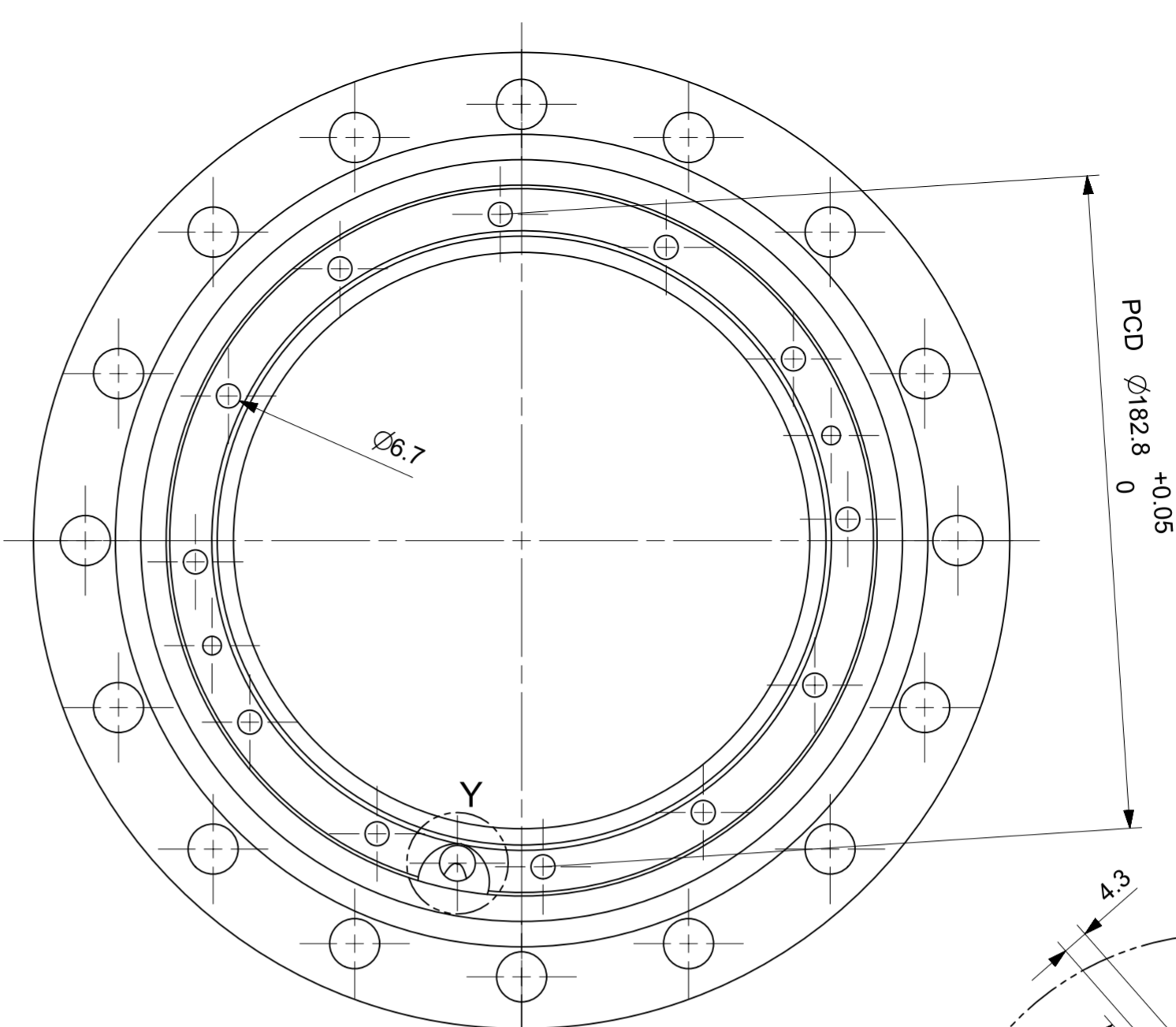
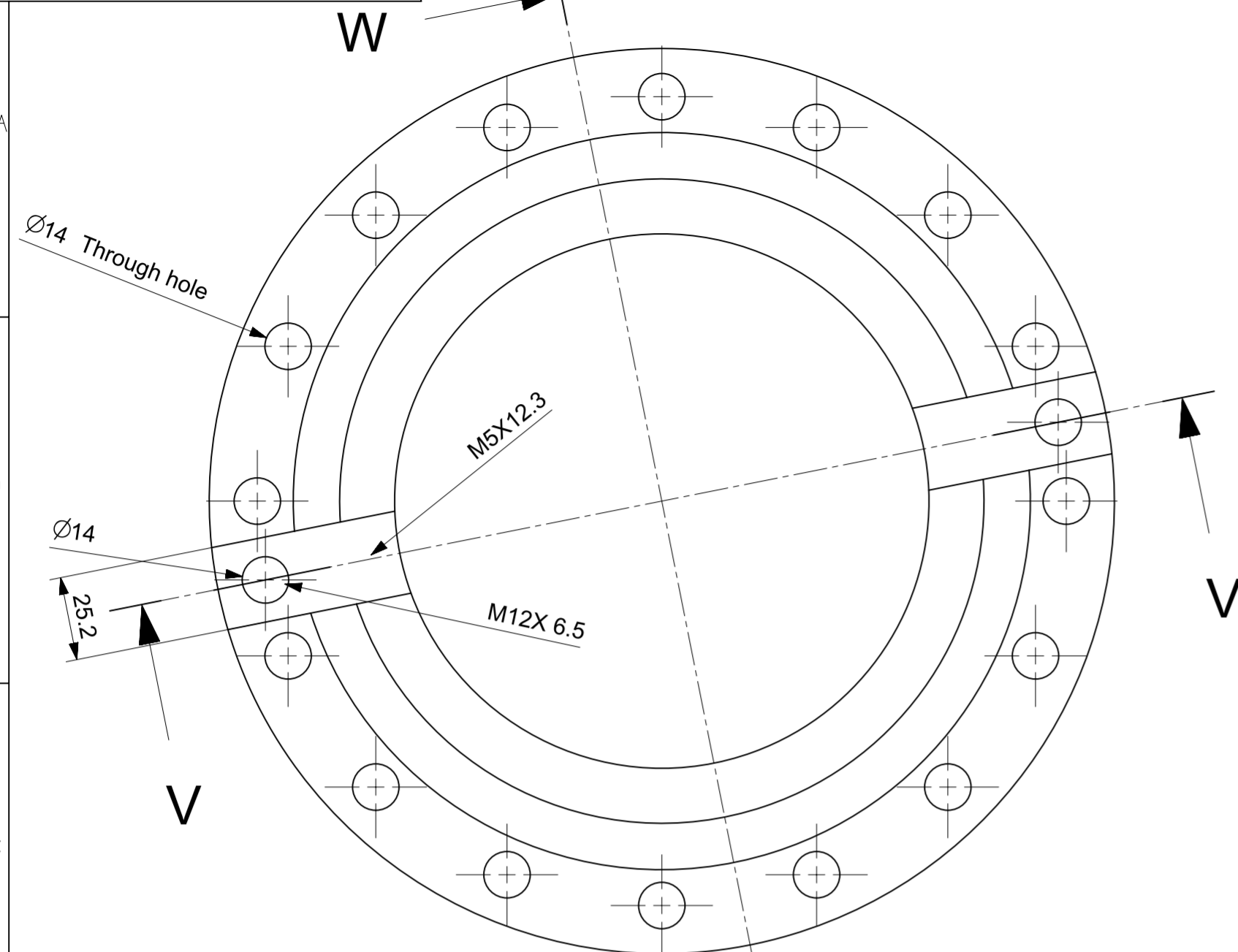

NOTE: 1. Max allowed tolerances are within ± 0.05 mm wherever not mentioned.  
2. Average surface roughness of 3.2 microns or better to be provided on all surfaces

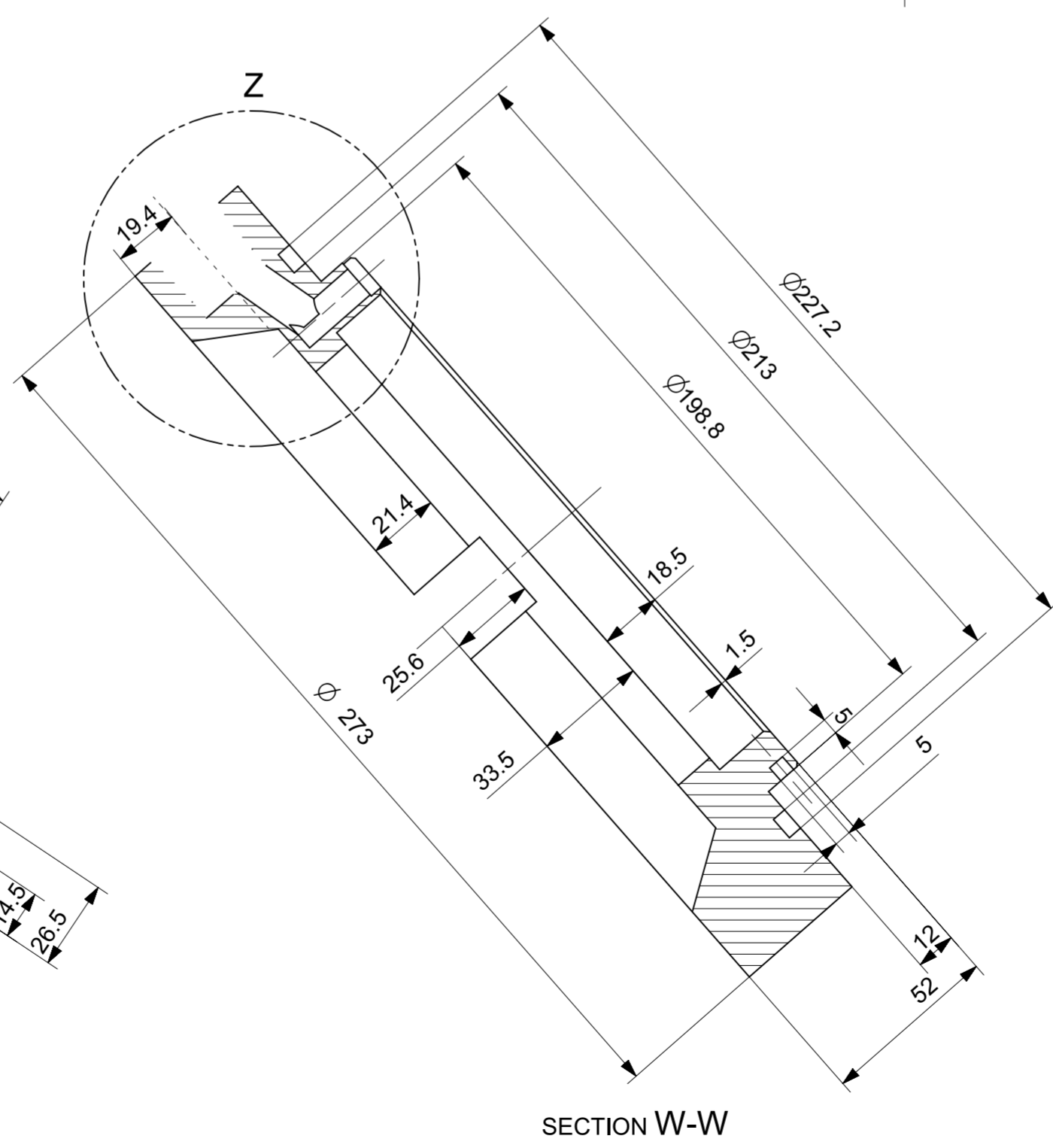
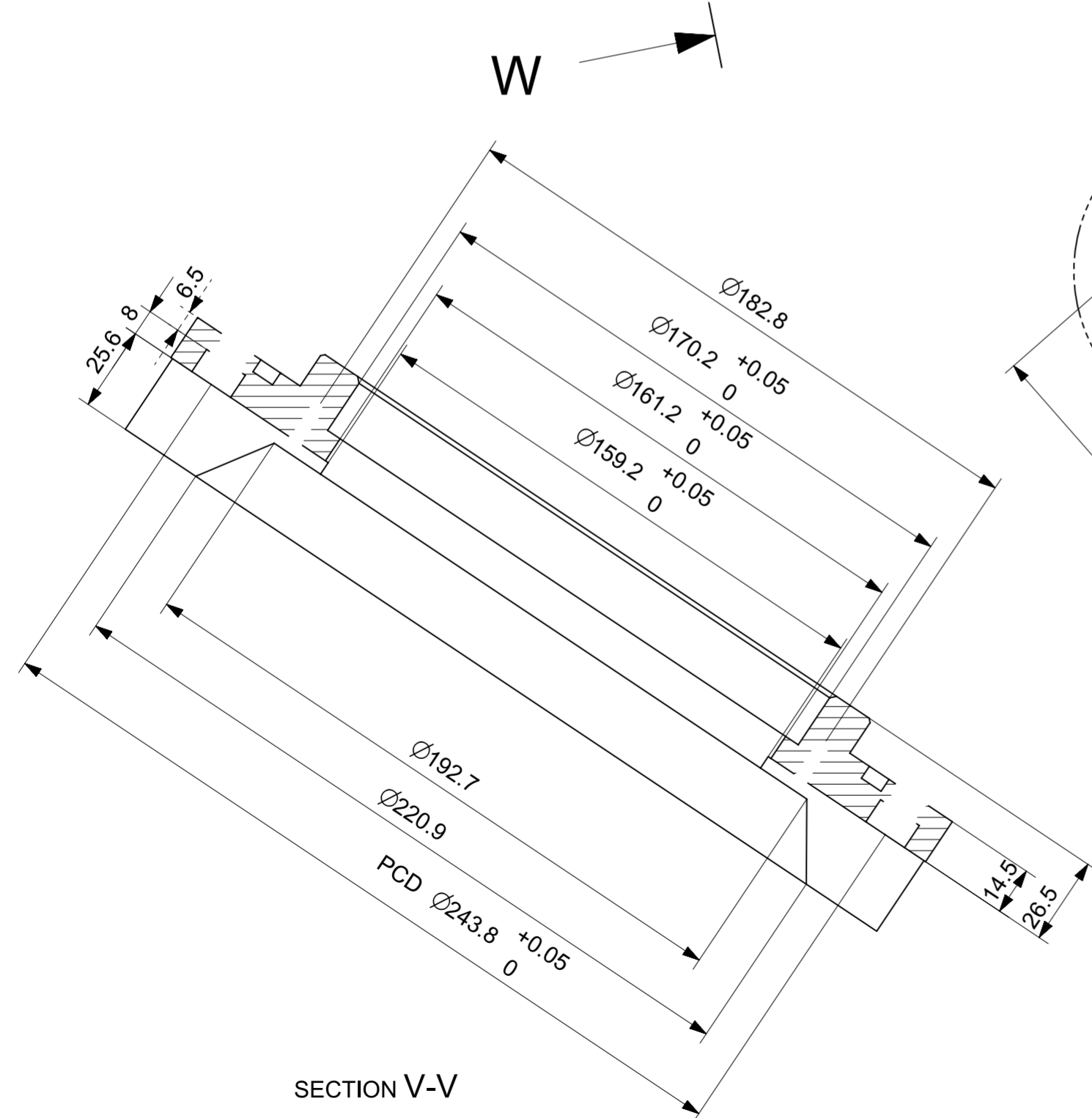

TYPE OF PRODUCT OR NAME OF CUSTOMER/PROJECT		DE Flange			
	DRN.	N Muni Kumar	SIGN.	DATE	NO. OF VAR.
	CHD.	A suresh Babu		14.12.2021	
	APPD.	Manish Agrawal		14.12.2021	N.A
DEPT.	MDF		SCALE	WEIGHT (K.G)	8.99
CODE	41		NTS	MAT.	-SS316
TITLE		REF. TO ASSY DRG.		ITEM NO.	NO. OF ITEMS
DE Flange		NA			
DRAWING NO.				REV.	
FS-DE-2021-07				00	
SHEET NO. 01		NO OF SHEETS 01			

DRG. NO. FS-DE-2021-03

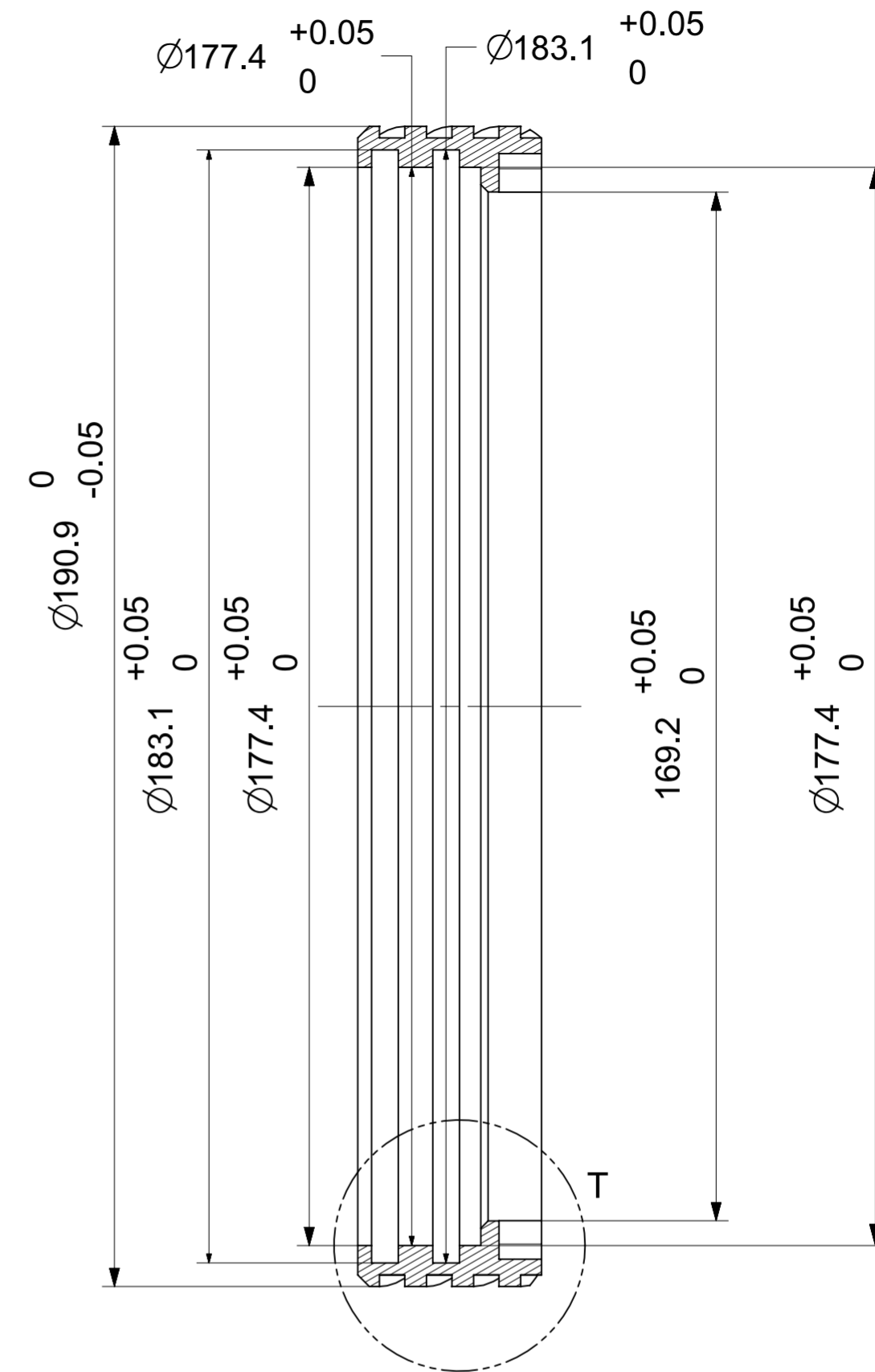
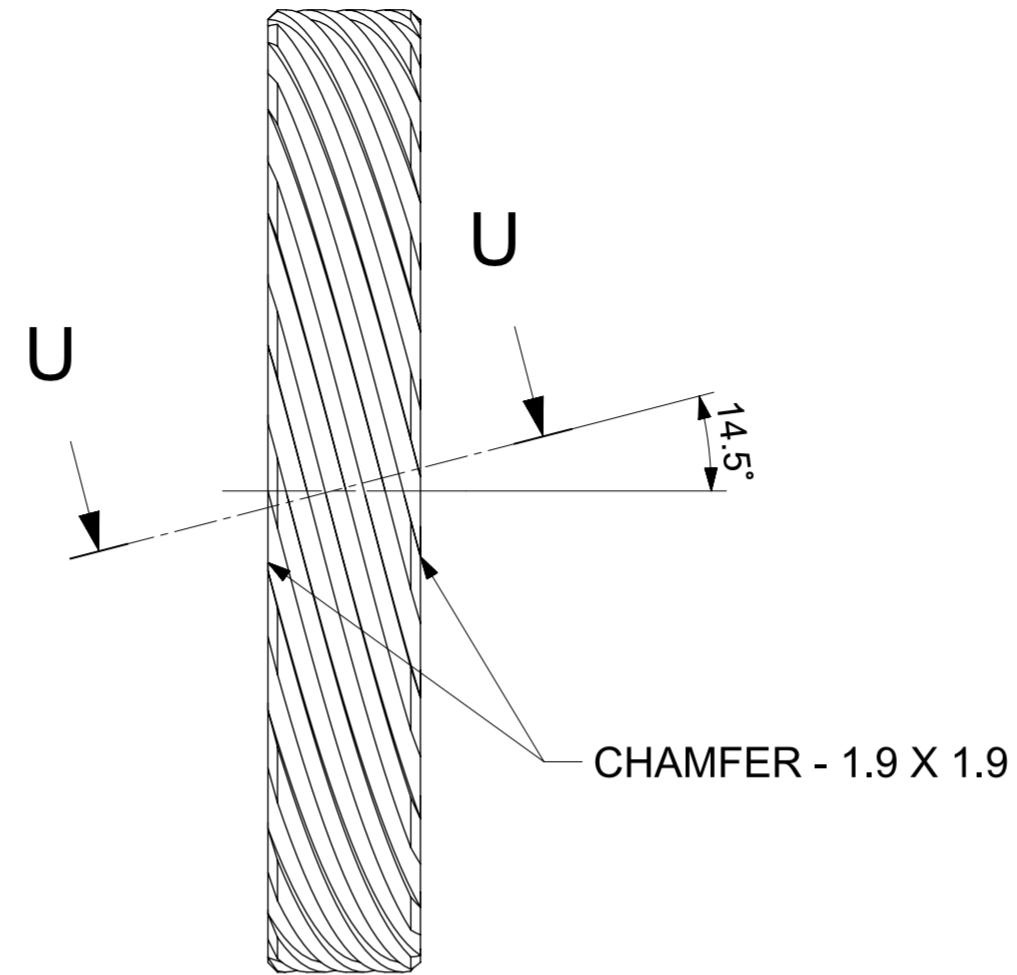
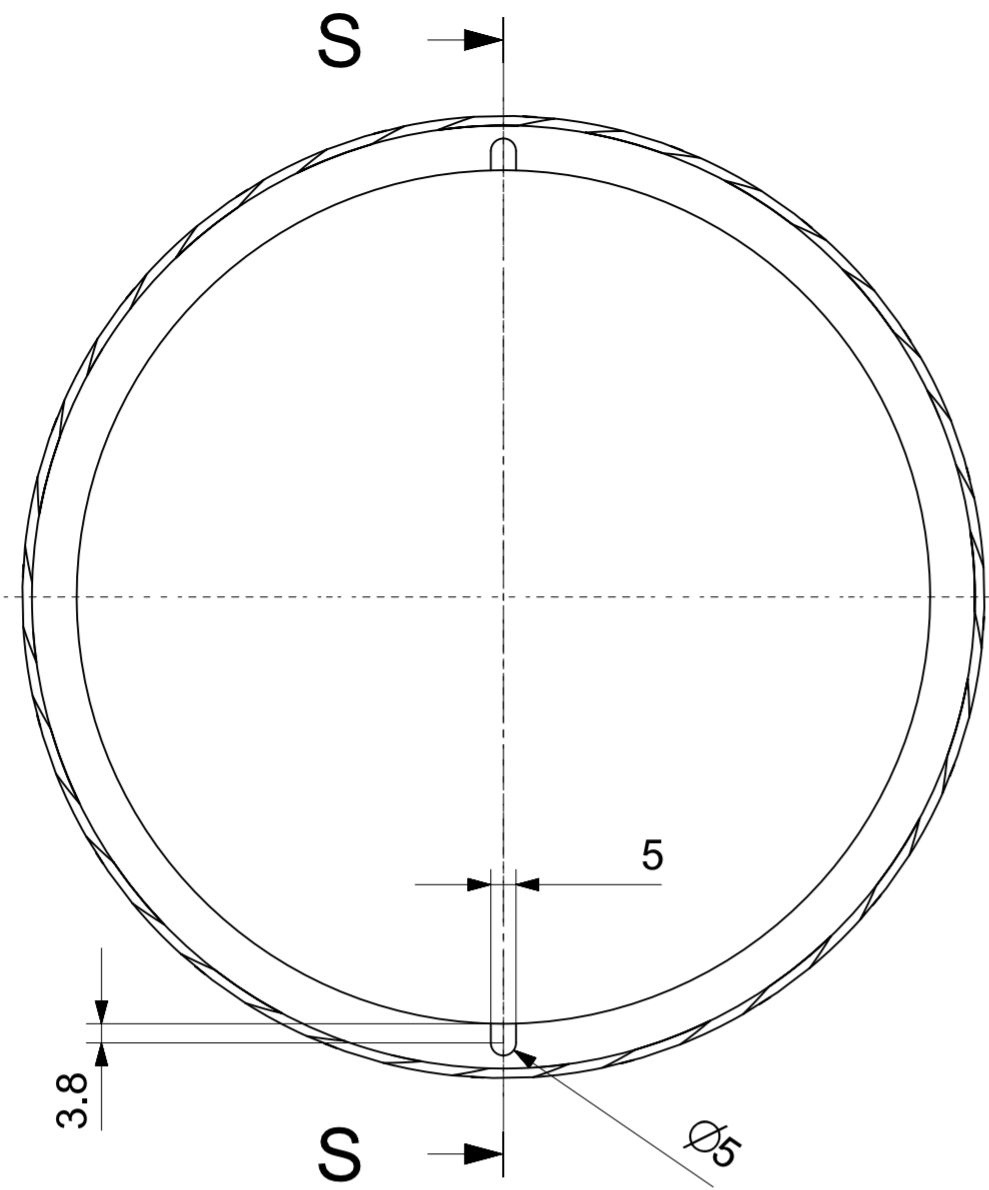

SECTION S-S

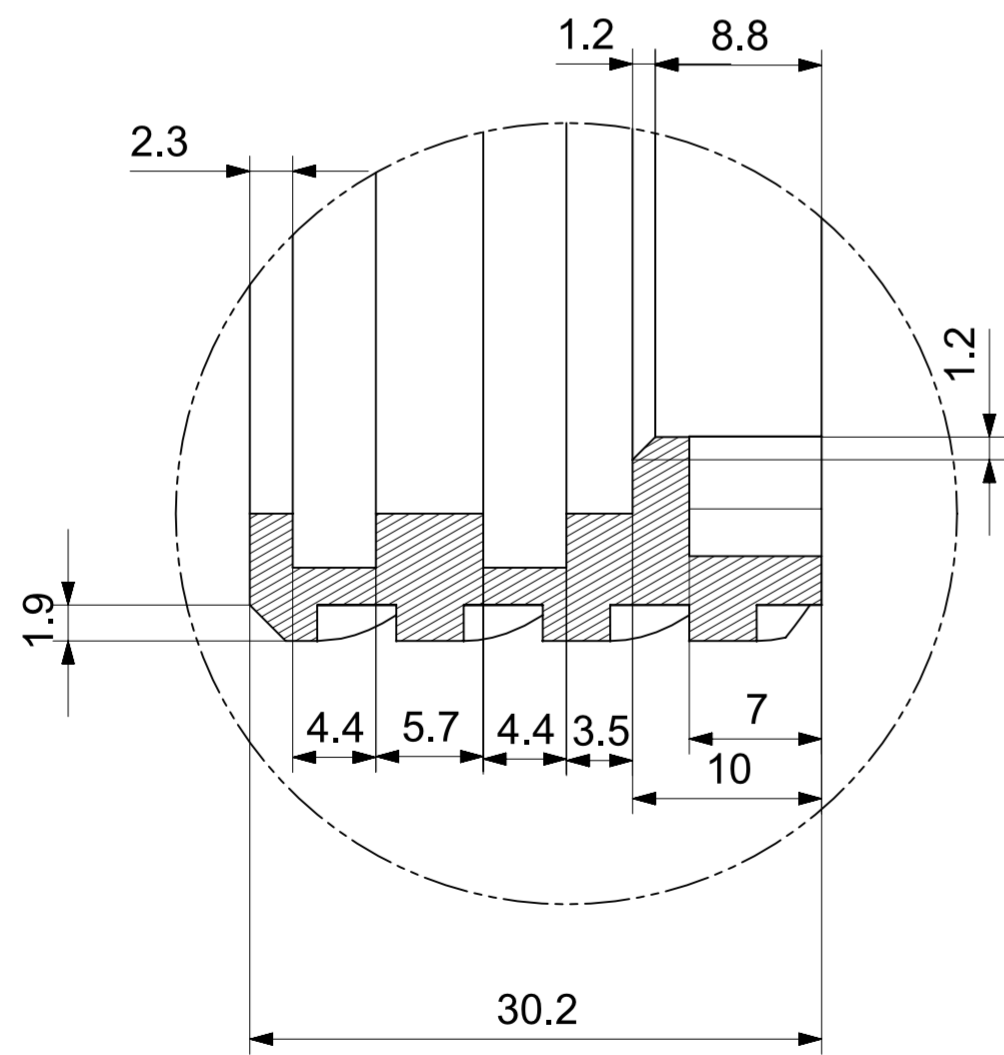

DETAIL T  
SCALE 5:2

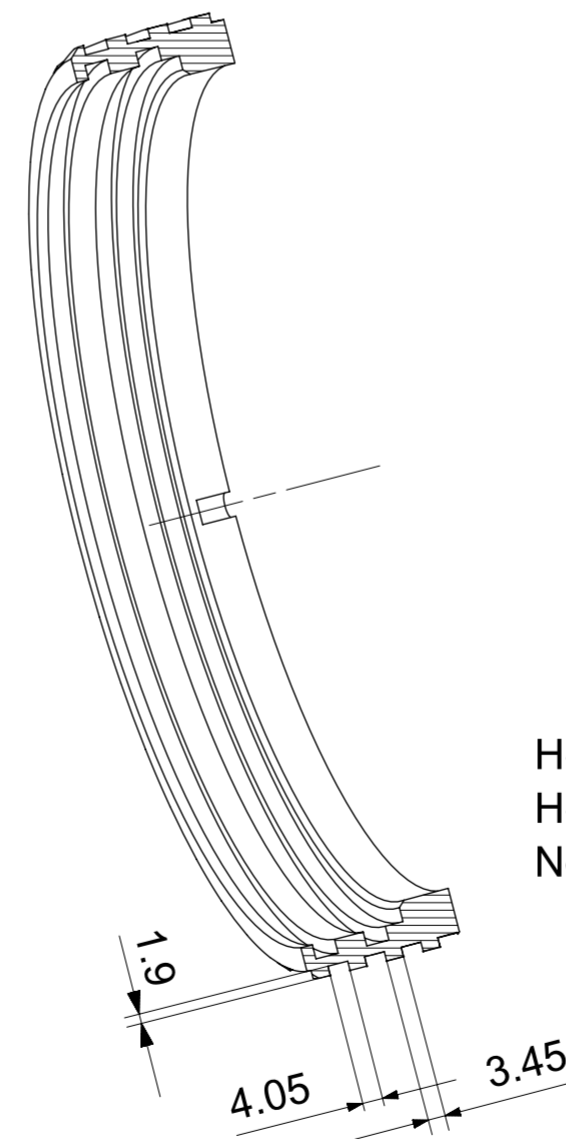

Helical grooves -  
Helix angle- 14.5°  
No of grooves - 20

SECTION U-U

NOTE: 1. Average surface roughness of 3.2 microns or better to be achieved on all surfaces.  
2. Maximum allowable tolerance is ±0.05mm wherever not mentioned.

TYPE OF PRODUCT OR NAME OF CUSTOMER/PROJECT		DE IPS			
BHARAT HEAVY ELECTRICALS LTD, Corporate R&D, HYDERABAD	DRN.	N Muni Kumar	SIGN.	DATE	NO. OF VAR.
	CHD.	A suresh Babu		13.12.2021	
	APPD.	Manish Agrawal		13.12.2021	N.A
DEPT.	MDF	SCALE WEIGHT (K.G) 0.81 MATERIAL - SS 420	REF. TO ASSY DRG.		ITEM NO.
CODE	41		NA		NO. OF ITEMS
TITLE			DRAWING NO.		REV.
DE IPS			FS-DE-2021-03		00
SHEET NO. 01			NO OF SHEETS 01		

THE INFORMATION ON THIS DOCUMENT IS THE PROPERTY OF BHARAT HEAVY ELECTRICALS LIMITED.  
IT MUST NOT BE USED DIRECTLY OR INDIRECTLY IN ANY WAY DETRIMENTAL TO THE INTEREST OF THE COMPANY.

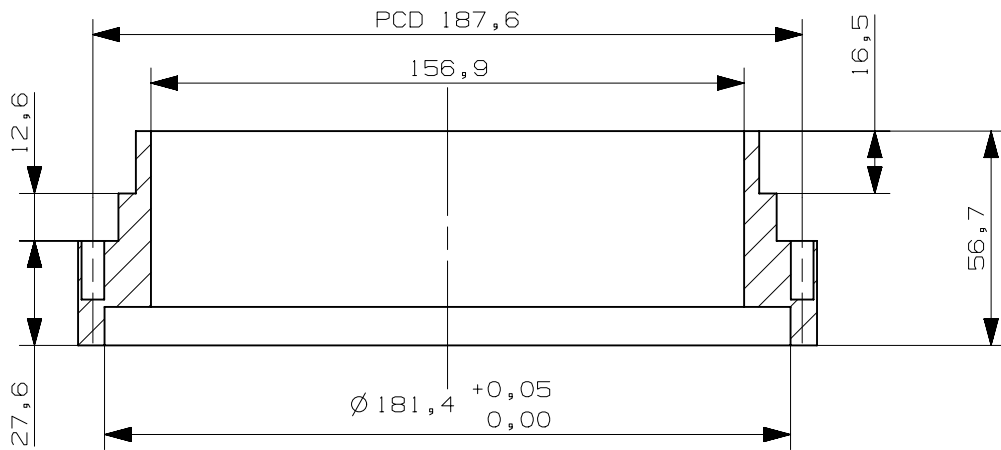
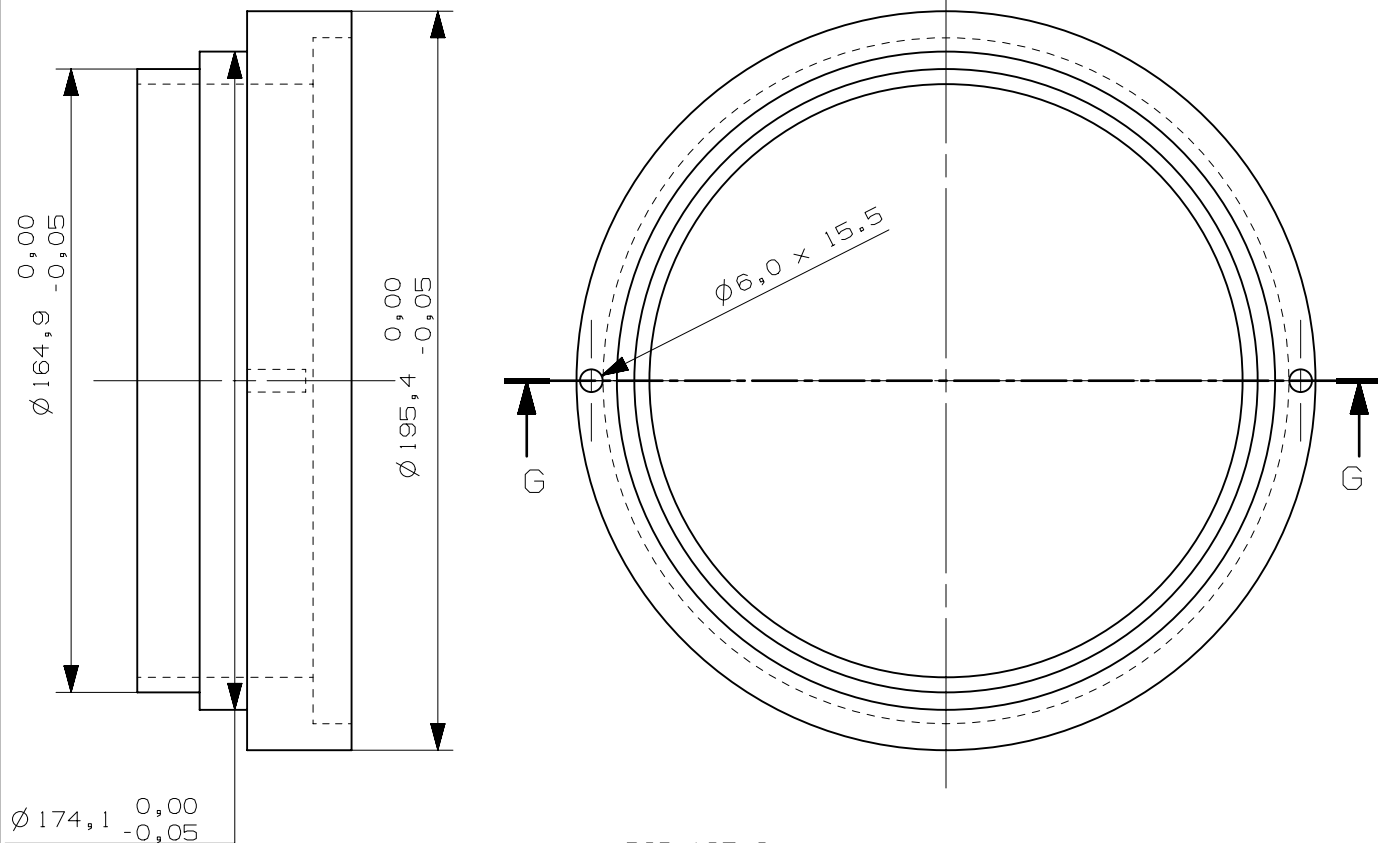

SECTION G-G

NOTE: 1. Average surface roughness of 3.2 microns or better to be achieved on all surfaces.  
2. Maximum allowable tolerance is ±0.05mm wherever not mentioned.

TYPE OF PRODUCT OR NAME OF CUSTOMER/PROJECT: DE SRH



BHARAT HEAVY ELECTRICALS LTD.  
Corporate R&D HYDERABAD

	NAME	SIGN	DATE	
DRN.	N Muni Kumar		14.12.2021	NO.OF VAR.  NA
CKD.	A Suresh Babu		14.12.2021	
APPD.	Manish Agrawal		14.12.2021	

DEPT. MDF		SCALE	WEIGHT(K.G.) 2.7	REF.TO ASSY.DRG.	ITEM NO.	NO.OF ITEM
CODE 41		NTS	MAT. - SS420			
TITLE DE SRH				DRAWING NO. FS-DE-2021-06		REV. 00
			SHT.NO. 01	NO.OF SHT. 01		

INVENTORY NO. SIGN. & DATE REF. DRG. NO. COMPUTER NO.

## Annexure- II to Enq 41210161

Restrictions on Procurement from a bidder of a country which shares a land border with India:

- 1) Any Bidder from a country which shares a land border with India will be eligible to bid in this tender only if the bidder is registered with the Competent Authority.
- 2) "Bidder" (including the term 'tenderer', 'consultant' or 'service provider' in certain contexts) means any person or firm or company, including any member of a consortium or joint venture (that is an association of several persons, or firms or companies), every artificial juridical person not falling in any of the descriptions of bidders stated hereinbefore, including any agency branch or office controlled by such person, participating in a procurement process.
- 3) "Bidder from a country which shares a land border with India" for the purpose of this Order means:-
  - a. An entity incorporated, established or registered in such a country; or
  - b. A subsidiary of an entity incorporated, established or registered in such a country; or
  - c. An entity substantially controlled through entities incorporated, established or registered in such a country; or
  - d. An entity whose beneficial owner is situated in such a country; or
  - e. An Indian (or other) agent of such an entity; or
  - f. A natural person who is citizen of such a country; or
  - g. A consortium or joint venture where any member of the consortium or joint venture falls under any of the above
- 4) The beneficial owner for the purpose of (3) above will be as under:
  - a. In case of a company of Limited Liability Partnership, the beneficial owner is the natural person(s), who, whether acting alone or together, or through one or more juridical person, has a controlling ownership interest or who exercises control through other means.

Explanation –

    - (i) "Controlling ownership interest" means ownership of or entitlement to more than twenty-five percent of shares or capital or profits of the company;
    - (ii) "Control" shall include the right to appoint majority of the directors or to control the management or policy decisions including by virtue of their shareholding or management rights or shareholders agreements or voting agreements
  - b. In case of a partnership firm, the beneficial owner is the natural person(s) who, whether acting alone or together, or through one or more juridical person, has ownership of entitlement to more than fifteen percent of capital or profits of the partnership;
  - c. In case of an unincorporated association or body of individuals, the beneficial owner is the natural person(s), who, whether acting alone or together, or through one or more juridical person, has ownership of or entitlement to more than fifteen percent of the property or capital or profits of such association or body of individuals;

- d. Where no natural person is identified under (a) or (b) or (c) above, the beneficial owner is the relevant natural person who holds the position of senior managing official;
  - e. In case of a trust, the identification of beneficial owner(s) shall include identification of the author of the trust, the trustee, the beneficiaries with fifteen percent or more interest in the trust and any other natural person exercising ultimate effective control over the trust through a chain of control or ownership.
- 5) An agent is a person employed to do any act for another, or to represent another in dealings with third person.

Certificate to be submitted along with tender:

“ I have read the clause regarding restrictions on procurement from a bidder of a country which shares a land border with India; I certify that this bidder is not from such a country or; if from such a country, has been registered with the Competent Authority. I hereby certify that this bidder fulfills all requirements in this regard and is eligible to be considered. (Where applicable, evidence of valid registration by the Competent Authority shall be attached)”.