



ANNEXURE – A to OPEN TENDER

Open tender for Procurement of "SICKLE SPANNER" as per BHEL Drawing & Quantities as listed below.

NOTICE INVITING TENDER:

e-tenders are invited for the supply of "SICKLE SPANNER" as per BHEL Drawing, Specification, Standards and Quantities as listed below.

SL NO	DESCRIPTION	TECHNICAL SPECIFICATION	QUALITY PLAN REQUIREMENT	QUANTITY / UNIT	TENTATIVE DELIVERY SCHEDULE
001	SICKLE SPANNER (PIN TYPE) D100-D105	AS PER DRG. NO. 3-55-000-02541.	MQP	5 NOS.	2 MONTHS AFTER PO
002	SICKLE SPAN (FLAT TYPE) D250-D270	AS PER DRG. NO. 3-55-000-02533	MQP	5 NOS	2 MONTHS AFTER PO

Destination -BHEL RANIPET, District: VELLORE, TAMILNADU - 632 406

Please submit your Sealed Bid (Two Part Bid) offer to below address.

Dy.Manager/Purchase
BAP, BHEL Ranipet
Tamilnadu-632406
Email: ashokpal@bhel.in
Ph: 04172 284024

We are pleased to inform you to register your firm thro' the following link.

Following are the formalities to be completed by your company for registration purpose.

Recently, we have switched over to online Supplier Registration Form as per our corporate guidelines. Supplier Registration Form is to be fed in our BHEL website portal and download the Supplier Registration Form from online portal and the same is to be sent to us for processing your registration activity.

We request to visit our Web Site: www.bhel.com and click under heading "Supplier Registration" and fill up the "**Supplier Registration Form**" which is available in the Online Supplier Registration Portal.

Or else, copy the following URL Link and paste in the web link address: http://www.bhel.com/vender_registration/vender.php and proceed with.



Qualifying criteria - Pre-Qualification Requirement (PQR)

Pre-Qualification Requirements (PQR) for SICKLE SPANNER:

Intending firms / Vendors shall comply and fulfill the criteria of satisfactory execution of similar products as given below as minimum requirements:

Vendors who satisfy the following criteria can only quote.

Pre-qualification criteria (PQR):

PRE-QUALIFICATION REQUIREMENT (PQR) FOR SUPPLY OF SICKLE SPANNER			
Sl. No	Pre- Qualification Criteria		Bidders' Remarks/ Comment/ Confirmation
1	Bidder should be a Manufacturer	Registration Certificate /Certificate of incorporation/ Udyam Registration Certificate	
2	Bidder must have successfully executed purchase order of "Sickle Spanner" of same /similar/higher size in the last 3 years from the date of tender opening. In support of past experience, bidder must submit at least one purchase order copy invoice and acceptance letter from customer /SRV etc.	Purchase Order copies with related Invoice /GRN/SRV details	
3	Bidder is not banned /kept on hold/black listed /given business holiday for a specified period by any Public Sector Undertaking or Government Department/BHEL Unit.	Self-declaration to be submitted by Bidder	
4	BHEL reserves the right to verify the information provided by bidder. In case the information is found to be false/incorrect, the offer shall be rejected and action will be taken as per BHEL extant rules.	Bidder to accept	
NOTE: - a. BHEL reserves the right to verify the information provided by vendor. In case the information provided by vendor is found to be false/incorrect, the offer shall not be considered. b. All the documents submitted shall be self-attested.			



BAP:RANIPET

BHARAT HEAVY ELECTRICALS LIMITED

(A Government of India Undertaking)

Boiler Auxillaries Plant

Indira Gandhi Industrial Complex, Ranipet - 632406 , INDIA

Phone :04172 - 254654, 284133

Fax No. : 04172-241179, 241131

Email : ashokpal@bhelrpt.co.in

LETTER / FAX ENQUIRY

To : **M/S**
Dear Sir(s),

ENQUIRY NO. : 5220714E

SUB : REQUIREMENT OF

ENQUIRY DATE : 26/08/2022

REF : 5220714E DT :

DUE DATE : 16/09/2022

Please Submit your lowest quotation on FIRM PRICE basis.

FAX TO :

26/08/2022

Sln	Mcd	Description	Qty	Unit	Lot Sln	Lot Qty	Dly Dt
001	961630100105		5.00	NO	001	5.000	30/11/2022
		961630100105 SICKLE SPANNER (PIN TYPE) D100-D105 AS PER DRG. NO. 3-55-000-02541.					
002	961630250270		5.00	NO	001	5.000	30/11/2022
		961630250270 SICKLE SPAN (FLAT TYPE) D250- D270 AS PER DRG. NO. 3-55-000-02533					

(1)PLEASE SUBMIT YOUR MOST COMPETITIVE OFFER (ON FIRM PRICE BASIS) IN 2 PARTS. PART 1:TECHNO-COMMERCIAL BID & PART 2:PRICE BID. (2)FILL UP SIGN & SUBMIT ANNEXURE A & B, UDYAM REG. CERTIFICATE, MQP, BIDDER ELIGIBILITY ETC. ALONG WITH TECHNICAL BID (3). RA IS NOT APPLICABLE FOR THIS TENDER.

REGARDS

MANAGER / PURCHASE

Manufacturer's Logo, if available		MANUFACTURER'S NAME & ADDRESS		MANUFACTURING QUALITY PLAN				PROJECT: BHEL PO NO & DATE: MQP NO: DATE: DD/MM/YYYY				
Format No				PRODUCT:				REV NO:				
				SUB-SYSTEM :				PAGE: 1 OF 2				
SL. NO	COMPONENT & OPERATIONS	CHARACTERISTICS	CLASS	TYPE OF CHECK	QUANTUM OF CHECK	REFERENCE DOCUMENT	ACCEPTANCE NORMS	FORMAT OF RECORD	AGENCY			REMARKS
									M	C	N	
1	2	3	4	5	6	7	8	9	D**	**	10	11

1.0	RAW MATERIALS & BOUGHT OUT ITEMS (BOI):											
2.0	INPROCESS CONTROLS:											
3.0	FINAL INSPECTION :											
4.0	PAINING, MARKING, PACKING AND PRESERVATION:											

		LEGEND: * RECORDS IDENTIFIED WITH "TICK" (✓) SHALL BE ESSENTIALLY INCLUDED BY SUPPLIER IN QA DOCUMENTATION. ** M: MANUFACTURER, C: BHEL / BHEL AIA, N: CUSTOMER; P: PERFORM, W: WITNESS, V: VERIFICATION; CLASS: A - CRITICAL; B - MAJOR; C – MINOR; MTC- MILL /MANUFACTURER'S TEST CERTIFICATE; IR- INSPECTION REPORT.
PREPARED BY	REVIEWED & APPROVED BY	
MANUFACTURER	MAIN SUPPLIER (BHEL)	
SIGNATURE & SEAL		

Manufacturer's Logo, if available 547744/2021/BAPQF-LEC		MANUFACTURER'S NAME & ADDRESS BHEL		MANUFACTURING QUALITY PLAN				PROJECT: BHEL PO NO & DATE:					
Format No				PRODUCT:				MQP NO:		REV NO:			
				SUB-SYSTEM :				DATE: DD/MM/YYYY		PAGE: 2 OF 2			
SL. NO	COMPONENT & OPERATIONS	CHARACTERISTICS	CLASS	TYPE OF CHECK	QUANTUM OF CHECK	REFERENCE DOCUMENT	ACCEPTANCE NORMS	FORMAT OF RECORD	AGENCY			REMARKS	
1	2	3	4	5	6	7	8	9	M	C	N	10	11

NOTES:

1. Latest revision of standards & specifications shall apply.
2. Materials shall be procured in compliance to Functional Technical Specification.
3. Inspection shall be in compliance with approved Quality Control Procedure for the product.
4. Qualified Personnel shall carry out NDT with compliance to approved NDT Procedures and Acceptance Norms, as per ASME Section V.
5. Gauges and measuring Instruments, with valid calibration only shall be used
6. Cleaning and Painting of products shall be carried out as per Approved Painting Schedule as applicable.
7. Finished Products shall be packed to comply with approved Packing Schedule.
8. BHEL Authorized representatives shall have the right to witness the necessary inspection and testing of goods mentioned in the PO. Inspection / Inspection wavier / approval by BHEL does not absolve Supplier's responsibility for conformity of the specification as per the terms of PO.
9. QA Documentation package shall include copy of approved Data Sheets/ Drawings & QP, along with all Material Test Certificate (MTCs), CHPs, Material Dispatch Clearance Certificate for all items.
10. This QP shall be read along with relevant PO, BHEL drawing and approved data sheet.
11. This QP is applicable for mandatory spare also as applicable.

		LEGEND: * RECORDS IDENTIFIED WITH "TICK" (✓) SHALL BE ESSENTIALLY INCLUDED BY SUPPLIER IN QA DOCUMENTATION. ** M: MANUFACTURER, C: BHEL / BHEL AIA, N: CUSTOMER; P: PERFORM, W: WITNESS, V: VERIFICATION; CLASS: A - CRITICAL; B - MAJOR; C - MINOR; MTC- MILL /MANUFACTURER'S TEST CERTIFICATE; IR- INSPECTION REPORT.
PREPARED BY	REVIEWED & APPROVED BY	
MANUFACTURER	MAIN SUPPLIER (BHEL)	
SIGNATURE & SEAL		

ANNEXURE –“A”

ENQUIRY No.

COMMERCIAL TERMS AND CONDITIONS

(To be filled in full and to be submitted along with offer)

SL. NO	DESCRIPTION	BHEL'S REQUIREMENT	SUPPLIER'S COMMENTS
01	PRICE	Firm till completion of order.	
02	DELIVERY TERMS	FOR, DESTINATION (BHEL,Ranipet-Stores)	
03	GST	Applicable GST extra on basic price to be indicated by supplier. (IGST/SGST/CGST/UTGST)	
04	MSME STATUS (MICRO/SMALL/MEDIUM)	To be indicated by supplier.	
05	PAYMENT	For MSE vendors 100% within 45 days after receipt & acceptance of materials at our end. For NON - MSE vendors "100% within 90 days of receipt and acceptance of materials at our stores". (Please confirm your acceptance for the same. In the event of any deviation in the above payment terms the following loading on your base rate will be done as below." Base rate of SBI (as applicable on the date of techno commercial bid opening) + 6% shall be considered for loading for the period of relaxation sought by you")	
06	DELIVERY PERIOD	To be indicated by supplier (In terms of no of weeks form the date of PO)	
07	L.D.CLAUSE	As indicated in Enquiry (as per IMPORTANT NOTE) Confirmation L.D. clause as indicated in Enquiry @ 0.5% per week subject to a maximum of 10% for the delayed delivery. (In case any bidder is not accepting the above penalty for delayed Supply, the offer of bidder shall be loaded to the extent to which it is not agreed by the bidder. Example: If the Supplier has accepted for maximum 5% penalty clause, then balance 5% will be loaded for evaluating lowest bidder)	
08	OFFER VALIDITY	Minimum 90 days from the date of Technical bid opening / 90 Days from the date of RA.	
09	INSPECTION BEFORE DESPATCH	Will be done at Your Works Before Dispatch No Extra cost shall be offered	
10	TEST CERTIFICATE	Required @ no extra cost	
11	GUARANTEE CERTIFICATE (Period: 12 months from the date of commissioning (or) 18 months from the date of supply which ever is earlier.	Required @ no extra cost	
12	INSTALLATION & COMMISSIONING	Supplier's scope (if required, please indicate charge per man day inclusive of to & fro, lodging, boarding to site on lump sum basis)	
13	PERFORMANCE BANK GUARANTEE (10% OF RDER VALUE)	Not Applicable.	
14	O&M MANUAL	Not Applicable	
15	RISK PURCHASE	SPECIFICALLY CONFIRM YOUR ACCEPTANCE	
16	Reverse Auction (RA)	RA is not applicable	
17	HSN # No of products	To be indicated for each product	
18	GST registration no	Supplier to indicate GST registration no of firm	
19	MANUFACTURING PLACE & COUNTRY	To be indicated by supplier.	

SIGNATURE WITH SEAL

ANNEURE – “B” TO ENQUIRY NO:
 REQUIREMENT OF TECHNICAL DETAILS /CONFIRMATION
 (To be filled in full and to be submitted along with offer)

S.NO	DESCRIPTION	BHEL'S REQUIREMENT	SUPPLIER'S COMMENTS
01	SPECIFICATION	Clause wise / Point wise confirmation to be given in TOTO for all specifications & to be submitted along with offer. (i.e. Xerox copy of specn duly filled with your acceptance / comments duly signed & sealed).	
02	DATA SHEET / DRGS	Filled Data Sheet and your Drgs are to be submitted along with offer. (if applicable).	
03	QUALITY PLAN	VQP to be submitted	
05	SPECIFICATION DEVIATION DISPOSITION REPORT (SDDR)	Attached SDDR to be filled & submit along with offer. (Even NO deviation is taken, NIL report to be submitted).	

Date:

SIGNATURE WITH SEAL

(to be submitted along with the offer)

SPECIFICATION DEVIATION DISPOSITION REPORT			
Specn	Item		
Enq. No & Date			
Vendor Name			
SPECN			
Page	Clause	Details Of Deviation With Reason	Disposition By BHEL
Signature Of Vendor			Reviewed By
"AGREED DEVIATION "			APPROVED BY
if any to be incorporated in the PO in the event of order.			

***(To be submitted In the company letter head by supplier)**

Subject: Public Procurement (Insertion of Rule 144 xi in the General Financial Rules 2017)

References:

<https://doe.gov.in/sites/default/files/OM%20dated%2023.07.2020.pdf>

<https://doe.gov.in/sites/default/files/Clarification%20to%20order%20public%20Procurement%20N%201%20dated%2023%20July%202020.pdf>

<https://doe.gov.in/sites/default/files/Exclusion%20from%20restrictions%20under%20Rule%20144%20xi%20of%20the%20General%20Financial%20Rules%202017.pdf>

From.

M/s _____

Address: _____

I/we are bidder from _____ (country). We does not belong to any of the below category mentioned.

1. Any of entity/office/workshop of your organisation/incorporation, established in a country sharing land border with India, If yes, provide the full address of all such locations.
2. Any of subsidiary of your organisation/incorporation, established in a country sharing land border with India, If yes, provide the full address of all such locations.
3. Any of entity/office/workshop of your organisation/incorporation, controlled in a country sharing land border with India, If yes, provide the full address of all such locations.
4. Any of entity whose beneficial owner is situated in a country sharing land border with India, If yes, provide the full name, address of all such locations.
5. Any Indian Agent available, If so, Provide details of address and contacts.
6. Any employee/directors who is/are citizen of country sharing land border with India, If yes, provide the full name, employee code and address of all such locations.
7. Any of consortium/joint venture of your organisation/incorporation, established in a country sharing land border with India, If yes, provide the full address of all such locations.

***(To be submitted In the company letter head by supplier)**

Meaning of beneficial owner

- 1) In case of a company or limited liability partnership, beneficial owner is the natural person, who, whether acting alone or together, or through one or more judicial person, has a controlling ownership interest or who exercises control through other means.

Explanation

- a) Controlling ownership interest means ownership of or entitlement to more than twenty-five percent of shares or capital or profits of the company.
 - b) "control" shall include the right to appoint majority of the directors or to control the management rights or shareholder's agreement or voting agreement.
- 2) In case of a partnership firm the beneficial owner is the natural person (s) who whether acting alone or together or through one or more judicial person, has ownership of the entitlement to more than fifteen percent of capital or profits of the partnership.
 - 3) In case of an unincorporated association or body of individuals, the beneficial owner is the natural person(s), who, whether acting alone or together or through one or more judicial person, has ownership of the entitlement to more than fifteen percent of the property or capital or [profits of such association or body of individual.
 - 4) Where no natural person is identified under (1) or (2) or (3) above, the beneficial owner is the relevant natural person who holds the position of senior managing official.
 - 5) In case of a trust, the identification of beneficial owner (s) shall include identification of the author of the trust, the trustee, the beneficiaries with fifteen percent or more interest in the trust and any other natural person exercising ultimate effective control over the trust and any other natural person exercising the ultimate effective control over the trust through a chain of control of ownership.
 - 6) An agent is a person employed to do any act for another, or to represent another in dealing with third person.

We have read the clause regarding restriction on procurement from a bidder of a country which shares a land border with India, we hereby declare that we do not belong to any such country and are eligible to be considered.

In case, any of information is found to be false, even after bid acceptance, immediate termination may happen and action will be taken as per law.

Format is being filled without altering any of the clause mentioned in the given format**

Dated: _____

Authorised Sign and stamp _____

DRAWING NO. 3-55-000-02533

ALL DIMENSIONS ARE IN MILLIMETRES
 FOR PRODUCTION
 REF. PR:QA:590 FOR PAINTING
 REF. PR:QA:500 FOR UNTOL. DIMNS.
 REF. APPLICABLE GMS FOR MATCODE&SPEC.

~ 3.2 ✓

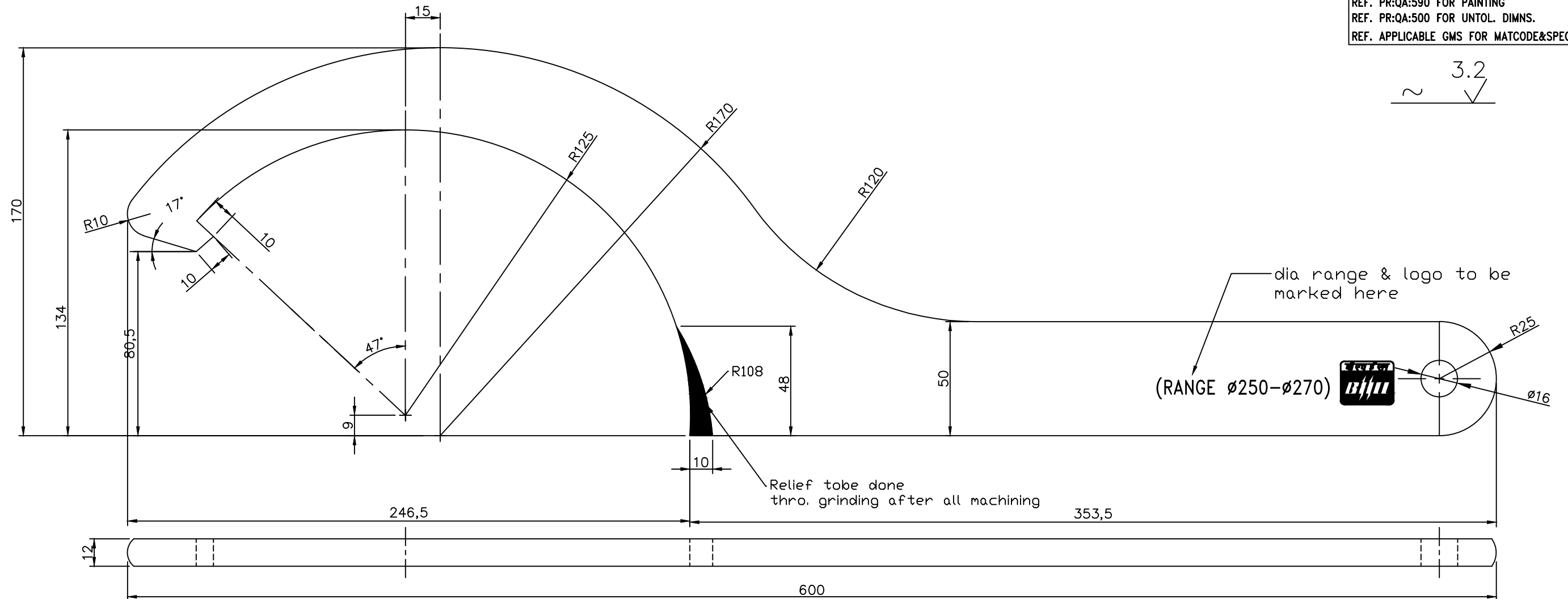

NOTE:-

- HARDEN AND TEMPER TO 36^{±0.1} HRC.
- BLACKENING TO BE DONE.
- CHAMFER EDGES TO 2x45°

01	SICKLE SPANNER (ø250-ø270)			961630250270		2.900				
				IS: 2073 62 C40		1				
VAR NO	ITEM NO	DESCRIPTION	CAT	DRAWING No.	ITEM NO VAR NO	MATL CODE MATL SPECN	A P C DI	UNIT WT QTY	GS	ZONE

CAUTION: The information on this document is the property of BHARAT HEAVY ELECTRICALS LTD. It must not be used directly or indirectly in any way detrimental to the interest of the company.		TYPE OF PRODUCT OR NAME OF CUSTOMER/PROJECT		BHARAT HEAVY ELECTRICALS LTD., UNIT: BOILER AUXILIARIES PLANT, RANIPET - 632 406.		DRN	VIKRAM SINGH	SIGN	DATE	NO.OF VAR.
		CHD	PRASANTA SAHA		28/12/19					
		APPD	PRASANTA SAHA		28/12/19					
		DEPT MTD	GRADE OF UNTOL.DIM	SCALE	WEIGHT (KG).	REF. TO ASSY/OLD DRG.		ITEM NO.	NO. OF ITEMS	
CODE	836	PR: QA: 500	NTS	-						
TITLE		SICKLE SPANNER (FLAT TYPE) (ø250-ø270)		CARD CODE	DRAWING NO.		REV			
				U 01	3-55-000-02533		00			

REV	DATE	ALTERED	CHECKED
ZONE			

DRAWING NO. 3-55-000-02541

ALL DIMENSIONS ARE IN MILLIMETRES
 FOR PRODUCTION
 REF. PR:QA:590 FOR PAINTING
 REF. PR:QA:500 FOR UNTOL. DIMNS.
 REF. APPLICABLE GMS FOR MATCODE&SPEC.

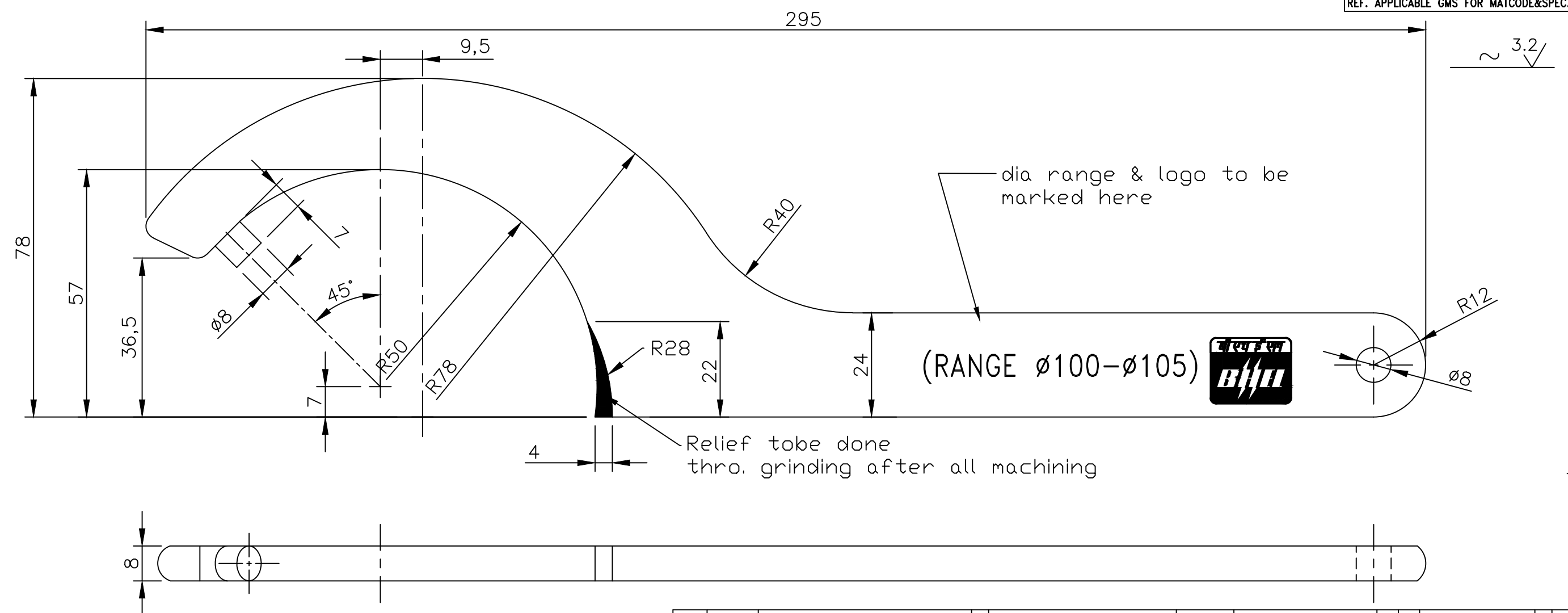

01	SICKLE SPANNER ($\phi 100-\phi 105$)			961630100105		0.500				
				IS: 2073 62 C40		1				
VAR NO	ITEM NO	DESCRIPTION	CAT	DRAWING No.	ITEM NO VAR NO	MATL CODE MATL SPECN	A P C UNIT DI	UNIT WT QTY	GS	ZONE

NOTE:-

- HARDEN AND TEMPER TO $36^{\pm 0.1}$ HRC.
- BLACKENING TO BE DONE.
- CHAMFER EDGES TO $2 \times 45^\circ$

CAUTION: The information on this document is the property of BHARAT HEAVY ELECTRICALS LTD. It must not be used directly or indirectly in any way detrimental to the interest of the company.

TYPE OF PRODUCT OR NAME OF CUSTOMER/PROJECT		BHARAT HEAVY ELECTRICALS LTD., UNIT: BOILER AUXILIARIES PLANT, RANIPET - 632 406.				
DRN	NAME	SIGN	DATE	NO. OF VAR.		
CHD	VIKRAM SINGH		28/12/19			
APPD	PRASANTA SAHA		28/12/19			
DEPT MTD	GRADE OF UNTOL. DIM	SCALE	WEIGHT (KG).	REF. TO ASSY/OLD DRG.	ITEM NO.	NO. OF ITEMS
CODE 836	PR: QA: 500	NTS	-			
TITLE				CARD CODE	DRAWING NO.	REV
SICKLE SPANNER (PIN TYPE) ($\phi 100-\phi 105$)				U 01	3-55-000-02541	00

REV	DATE	ALTERED
		CHECKED
ZONE		