



**COPYRIGHT AND CONFIDENTIAL**  
The information on this document is the property of **BHARAT HEAVY ELECTRICALS LIMITED**,  
It must not be used directly or indirectly in any way detrimental to the interest of the company.

# TECHNICAL SPECIFICATION

## FOR

# CENTRIFUGAL AIR BLOWER

<b>PROJECT</b>	<b>STP PROJECT,RAIPUR DEVELOPMENT AUTHORITY,RAIPUR</b>
<b>CUSTOMER</b>	<b>RAIPUR DEVELOPMENT AUTHORITY</b>
<b>CONSULTANT</b>	<b>M/s SFC,MUMBAI</b>

**Revisions:**  
Refer to record  
of revisions

Prepared by :

Rajeev Jain

Checked by :

(S.B.N.)

Approved by :

(MSSN)

Date :

11-10-2021



## INDEX

S. No.	DESCRIPTION
1.	Intent of Specification
2.	Special Instructions to Bidders
3.	Project Information
4.	Application of System
5.	Technical Details/Requirements
6.	Scope of Supply
7.	Equipment qualification criteria (EQC)
8.	Quality Plan & Inspection Agency & Testing
9.	Painting
10.	Packing and Forwarding
11.	Sub Vendors
12.	Documentation
13.	Price Bid Format
14.	Pre-Bid Clarifications
<b>LIST OF ANNEXURES</b>	
	Annexure 1 – P&IDs for All the 6 STP Projects
	Annexure 2 - Data Sheet of Air Blower-Motor Assembly
	Annexure 3- Price bid Format
	Annexure 4- Checklist for Air Blower
	Annexure 5- Packing & Forwarding Specification
	Annexure 6-Format for Equipment Qualification Criteria (EQC)/ Pre-Qualification Criteria (PQC)
	Annexure 7- QAP Guide Line & Formats
	Annexure 8- Sub-vendor List
	Annexure 9. Master DOC List Format



	Annexure 10- Deviation Format
	Annexure 11- Prebid Clarification Format

**DOCUMENTS TO BE SUBMITTED WITH THE BID:**

The bidder must submit the following documents along with their bid to enable BHEL to evaluate their offer.

- a) Duly filled in Air Blower-Motor Assembly[Annexure: 2]
- b) Preliminary GADs having Complete Details such as Foundation Details, Load Details, Dimensions etc.
- c) Performance Curves of Air Blower
- d) Un-priced copy of attached BHEL price bid formats [Annexure: 3] indicating quoted/not quoted against each row & column.
- e) Reference project details / documents meeting the Pre-Qualification Criteria/ Equipment qualification criteria / PTR [Annexure: 6]
- f) Checklist [Annexure: 4]
- g) Deviation list indicating No Deviation [Annexure: 10] \*\*

\*\* Bidder shall submit Annexure: 10 indicating as **NO DEVIATION** along with their offer. Any specific deviations, with respect to specification requirement due to design constraints and OEM limitation, which are impractical to meet, shall be raised in form of pre-bid queries as per Annexure: 11 before submission of Techno Commercial offer.

**In case the above-mentioned documents are not submitted with the offer, the offer of the bidder may be liable for technical rejection.**

**1. INTENT OF SPECIFICATION:**

This specification describes the requirement of Design, Engineering, Manufacturing, Assembling, Inspection, testing at manufacturer's works and Delivery properly packed and painted, transport of **Centrifugal Air Blower along with Motor including all Accessories/Auxiliaries** with all accessories as specified in this specification document and as per the requirement for the safe and trouble-free operation of equipment to be installed at site.

**2. SPECIAL NOTES TO BIDDERS**

- 2.1 This specification shall be read in conjunction with its enclosures. In case of any discrepancy arising between this specification & its enclosures, the most stringent of all shall be followed and shall over-ride others. Further, if a requirement in this specification or its enclosures, calls for decision of owner/BHEL, it shall be bidder's sole responsibility to clearly bring out the same distinctively in his technical tender offer, so as to enable owner/BHEL to furnish their decision. If such a requirement is not duly addressed by bidder during tender stage and same comes out during order execution stage, it shall be binding on the bidder to comply with the decision furnished by owner/BHEL then, without any cost, delivery, or any other commercial implications.
- 2.2 Any additional equipment, material, etc., which are not specifically mentioned here, but are required to make the supplied equipment complete in all respect, in accordance with the intent of this technical specification, contractual agreement, statutory requirements, relevant/applicable codes/standards, good engineering practices, and for safe and trouble-free operation, shall be deemed to be covered under the scope of this specification.
- 2.3 The Bidder shall accept full responsibility for the completeness and for the faultless working of all the equipment's. These shall be executed on the basis of proven design principle and in accordance with the latest state of the art in such a manner that the purpose to be served by the Air Blower unit is fulfilled in every respect and a maximum of operational dependability and efficiency are assured. Standardization of equipment, materials etc. shall be employed in the design. Care shall be taken to ensure safe operation as well as simplicity of assembling and dismantling of all parts of the plant.
- 2.4 Bidder shall quote strictly as per the scope of supply and requirements of this specification.
- 2.5 Bidder offer shall be strictly as per these specification requirements. Unsolicited or Alternate offers from the bidders will not be entertained.
- 2.6 In case bidder feels that it is necessary to exclude some components of scope of supply or some of the features of specification requirements due to any technical constraints, bidder shall bring the same to the notice of purchaser during pre-bid stage and take their prior approval before submission of their bid.
- 2.7 In case Bidder is unable to offer due to any specific requirement of specification; Bidder shall bring out the same in their regret letter. Otherwise, it will be considered that non-participation by the bidder is attributable to reasons other than any specification requirements.
- 3. APPLICATION OF SYSTEM:** Air Blowers are required for 6 Nos. of STP Project for Raipur Development Authority for 7.40 MLD STP AT SECTOR – 13/4.33 MLD STP AT SECTOR – 6/7.05 MLD STP AT SECTOR – 12/1.79 MLD STP AT SECTOR – 11a/0.872



MLD STP AT SECTOR – 11 b/3.98 MLD STP AT INDRAPRASTHA and each STP require 2 Nos. [1W+1S] of Centrifugal Air Blower for Bio Filter for 6 STPs project mentioned above is envisaged to provide air into Bio-Filter.

#### 4. PROJECT INFORMATION –

Sl. No.	Description	Details
1.	Owner	M/s. Raipur Development Authority
2.	Project	Installation of Sewage Treatment Plant, Raipur
3.	Owner's consultant	M/s SFC, Mumbai
4.	Location	Site is located in various Locality of Raipur City.
5.	Nearest Airport	Raipur, Chhattisgarh
6.	Nearest Railway Station	Raipur
7.	Longitude/latitude	21.2514° N, 81.6296° E
8.	Lowest temperature recorded (deg. C)	3.9
9.	Highest temperature recorded (deg. C)	32.3
10.	Elevation above MSL	409 m
11.	Maximum Ambient temperature for Electrical equipment / system (deg. C)	50
12.	Minimum Ambient temperature for Electrical equipment / system (deg. C)	13

Note: Any data required for designing the equipment, bidder may ask prior to the submission of bid.

#### 5. TECHNICAL DETAILS/REQUIREMENTS:

Sl. No.	Description	Rated Condition
1	Application	Transferring Foul Smell Air from SBR Tank to Bio Filter
2	No. of Blowers	2 Nos. (1W+1S) for Each of 6 STPs Project, Total: 12 Nos.
3	Type	Centrifugal Air Blower
4	Drive	V-belt driven/Direct Driven by squirrel cage induction motor(IE3 Motor)
5	Capacity	Refer Table-I
6	Discharge Pressure	Refer Table-I
8	Speed of Blowers	Less than or equal to 1500 rpm
9	Power Supply	3 Ph,415 V,+/- 10% Voltage Variation, 50Hz,+/- 5% Frequency variation, Combined Variation: +/- 10%, DOL Starting
10	Noise Level	85 dBA at 2.0 m in any direction
11	Material of Construction	Casing: Carbon Steel as per IS 2062 Gr. A, Impeller: Carbon Steel as per IS 2062 Gr. A, stand: Carbon Steel as per IS 2062 Gr. A, Shaft : SS410, Gaskets: Neoprene, Bearing: SKF/Equivalent Other Parts shall be as per Manufacturer Standard. * In case bidder can't meet above mentioned material, Bidder can offer Equivalent /Superior material suitable to the requirement.

**Table-I: Project wise Design Parameters:**

Sl. No.	Description	7.40 MLD STP AT SECTOR - 1	4.33 MLD STP AT SECTOR - 6	7.05 MLD STP AT SECTOR - 12	1.79 MLD STP AT SECTOR - 11a	0.872 MLD STP AT SECTOR - 11 b	3.98 MLD STP AT INDRAPRASTH A
i)	Centrifugal Air Blowers [Flow(In m <sup>3</sup> /hr, Head (In mlc)] <b>Quantity : 2 Nos. for Each Project</b>	3500m <sup>3</sup> /hr, 0.2 mwc	4900 m <sup>3</sup> /hr, 0.2 mwc	4500 m <sup>3</sup> /hr, 0.2 mwc	1200 m <sup>3</sup> /hr, 0.2 mwc	600 m <sup>3</sup> /hr, 0.2 mwc	2000 m <sup>3</sup> /hr, 0.2 mwc

**6. SCOPE OF SUPPLY**

The scope of supply for this enquiry is as given below:

**Quantity of Air Blower & Drive Assembly: 2 Nos. (1W+1S) of Centrifugal Air Blower**

**Total Quantity of Air Blower & Drive Assembly: 12 Nos. for all 6 STPs**

The scope of supply and technical details for each Centrifugal Air Blower & motor drive assembly is as given. Also the P&IDs (Annexure-1) shall be referred.

**6.1 Air Blower:**

Centrifugal Air Blowers complete with all accessories as per specification & required accessories for smooth running of Air Blower assembly. Performance requirement, Design and construction of the Air Blower shall be guided by the Manufacturer recommendation.

**6.2 Motor:****(i) Selection Criteria:**

The power rating of the Blower motor shall be the larger of following:

- (a) 10% above the maximum power requirement by the blower
- (b) End of Curve Requirement

- (ii) Motor shall be as per IS 325/IEC60034.  
Energy Efficient Class: IE 3 as per IS 12615.  
For Motor, Supply voltage is 415 V.

**(iii) The bidder shall strictly adhere to following condition while selection of motor:**

The bidder shall strictly adhere to following condition while selection of motor:

- a) Motors of 3000 rpm are not acceptable. In turn the bidder shall not consider Blowers/drives of 3000 rpm/ 2900 rpm. 2 pole motor shall not be considered anywhere in the project.



- b) All the motor shall be provided with class F insulation and with temperature rise limit of B class above ambient temperature when operating at full load.
- c) All the motors shall have overloading capacity as per latest revision of IS.
- d) The noise level during the operation of the Blower sets/ drive shall not exceed 85 dBA at a distance of 1.86 m from the Blower/drive.
- e) The mechanical vibration limits shall be as required by BS 4675: Part 1 to class III, subclass B or better. Vibration measurements on the drive and non-drive end of motor bearing, Blower bearing housing and base plates shall not exceed 2.8 mm/sec. RMS within  $\pm 10\%$  rated head, while the limit is 4.5 mm/sec RMS for balanced portion from shut off to maximum flow. The above indicated vibrations shall be measured at the manufacturer's works during testing. For the purpose of guarantees the site tests shall govern.
- f) All motor shall be on LT system. However, the motors above 75 KW shall be of slip ring type.
- g) Each motor upto 5 KW shall have DOL starter with O/C, short ckt protection, over load relay with single phasing protection along with ammeter, provision for remote start/stop. Overload relay shall be reset type from front of panel. All starters component shall follow type-II coordination chart of established manufactures with components of same make. Each starter shall have On/Off/Trip indication. All necessary selector switches like auto manual switch and local remote switches shall be installed.
- h) Motors above 5 KW and upto 30 KW shall have Star / Delta starter with O/C, short ckt protection, over load relay with single phasing protection along with ammeter, provision for remote start / stop O/C relay shall be reset from front of panel. All starter components shall follow type-II coordination chart of established manufactures with components of same make. Each starter shall have on/off/trip indication. All necessary selector switches like auto, manual switch and local, remote switches shall be installed.
- i) **Tests of Motors:**  
**Mechanical Completion Checks:**
- (i) Compare name plate details with the specification.
- (ii) Check for tightness of all bolts, clamps and connecting terminals.
- (iii) Check ground connection.
- (iv) Bearing lubrication.
- (v) Check clearance inside terminal box.
- (vi) Megger testing of motor winding and cables.
- (vii) Motor winding, control and power cables continuity checks.
- (viii) Resistance of motor winding.
- (ix) Check / calibration if RTDs, BTDS for bigger motors, flow switches ( in case of water cooled motors ) and if any other instrument mounted.

**Commissioning Test:**

- (i) Controls and interlocks.
- (ii) Ready test and settings.
- (iii) Phase sequence and rotation.



- (iv) Starting and no load currents.
- (v) No load operation ( observe variation, noise level, temperature of bearing and windings of motor , check speed of motor).
- (vi) On load operation, starting and running currents operation ( observe variations, noise level, temperature of bearing and windings of motor, check speed of motors), vibrations.
- (vii) In case of closed loop arrangement for cooling the windings of motor, inlet and outlet temperature of the cooling air / water.

Motors of 5.5 KW to 22 KW site rating shall be subject to performance tests but will not be witnessed.

Motors under 5.5 KW site rating shall be subject to “type test “standards. Type test certificates which shall include the following shall be provided for all motors:

Manufacture to BS.

- Class of Insulation.
- Type of cable fittings.
- Type of bearing sizes and lubricant.
- Type and rating of motor heaters.
- 

Motor testing shall be carried out in accordance with the requirements and relevant standards.

### 6.3 Type of Seal: As per manufacturing Standard

### 6.4 Inter connecting Piping & Instrumentation:

- a) BHEL Discharge Pipe Size: Refer Annexure-1  
Reducer/expander in order to meet BHEL discharge pipe.
- b) Flanges & Counter flanges with necessary gaskets & bolts at all terminal points. All counter flanges shall be of as per FRP/DI.

Flanges: FRP/DI

Fittings: FRP/DI

### 6.5 Following Accessories to be considered for Air Blower as a minimum:

- i) V-Belt
- ii) Belt Guard
- iii) Counter Flanges at Outlet
- iv) Inlet & Outlet Damper
- v) Motor Canopy.
- vi) Acoustic Enclosure (In case bidder is not able to meet noise criteria mentioned in spec.)
- vii) Any other accessories required to make the air blower assembly complete.

**Note: With respect to Accessories mentioned above;**

A) If any of above items indicated by the specified name are not applicable, bidder to offer alternative item serving the same function as per equipment's design and indicate below the item being replaced.

B) If bidder is not able to meet the above note, then bidder may mention "Not Applicable". However, if found applicable during detailed engg. stage or alternative item as per equipment design can serve the same function, bidder to supply the specified quantity without any delivery and commercial implications to BHEL.

**6.6 Necessary foundation bolts, nuts, shims/grouting pads etc.**

**6.7 Instrumentation:** Bidder to consider required instrumentation, which are required for smooth & trouble free operation as per manufacturer recommendation.

**6.8** All other items necessary for safe and smooth running of Blower & Accessories required to make the supplied equipment complete in all respect.

**6.9** Glands and lugs for power cable, control cable, Space heater cable and earthing cable (if any) suitable at Motor end has to be supplied along with the main equipment. Glands shall be Flame proof/weather proof (as per motor category) double compression type Nickel plated Brass (ET) shall be provided with back nut and PVC shroud. Lugs shall be tinned copper heavy duty lug Cable dimensions shall be furnished during detail engineering, accordingly glands, lugs shall be supplied.

**6.10 Commissioning Spares (For Each of 6 STPs):**

Two sets (One set for each Blower & motor assembly) [For Each 6 Nos. of STPs] of commissioning spares for Air Blower shall be quoted and included in scope of supply as per manufacturer's recommendation.

**6.11 Mandatory Spares: Not Applicable.****6.12 Special Tools & Tackles (For Each of 6 STPs):**

The bidder shall furnish a complete 1 sets [1 set each for Each Variety of Blower] for each of all special tools, wrenches etc. with necessary tools boxes as required for operation and maintenance [disassemble, assemble, or maintaining the unit] as a part of scope of supply. Bidder shall furnish a list of such tools along with offer for the system. Prices for the special tools and tackles shall be part of main scope of supply. No separate price shall be offered for the same.

**6.13 Recommended O&M Spares:**

Following O&M Spare to be supplied & the prices of the same to be indicated in Price bid format against each item as indicated.

- a) Seal-1 Set/Blower
- b) O-Rings & Gaskets-1 Set/Blower
- c) Bearing for Blower- 1Set/Blower
- d) Bearing for Motor- 1Set/Blower

**1 Set stands for replacement of total requirement for 1 Blower.**



## 7. EQUIPMENT QUALIFICATION CRITERIA (EQC) / PRE-QUALIFICATION CRITERIA (PQC):

Vendor shall meet the qualification criteria specified elsewhere in the specification and shall furnish duly filled-in Experience Record Proforma /Pre-qualification Criteria in the prescribed format as per Annexure-6.

The Bidder shall furnish reference of each Blower model meeting requirement as mentioned in prequalification criteria.

The purchaser reserves the right to prescribe / request for additional drawings / documents / information / clarifications / justifications during the evaluation of the PQC & Offer, in order to satisfy himself regarding capability and capacity of Bidder / its sub-vendor(s) and the proposed arrangement.

The purchaser shall also reserve right to verify the information furnished by bidder. In case the information / documents / data furnished by bidder are found to be false / incorrect, the technical offer that bidder will be liable for rejection.

## 8. QUALITY PLAN & INSPECTION AGENCY & TESTING:

### **Quality Plan: Please refer annexure-7 for typical quality plan:**

Bidder to furnish Quality Plan to BHEL for approval after award of contract. Quality plan will be reviewed during detailed Engineering stage with respect to Inspection, standard Engineering practices & Specification Requirements and various tests and stages of inspection and appropriate agencies for Inspection will be Intimated. Bidder to abide by the same.

### **Inspection agency:**

BHEL/Third Party appointed by BHEL. The various review/witness/observation stages by Individual agencies (or) Group of Agencies as above will be in line with approved quality plan.

Performance test: Bidder to conduct performance test as per applicable test standard as a minimum. Performance test procedure to be furnished for BHEL approval prior to testing.

**Material Test Report:** Material test report to be furnished for BHEL review.

### **Performance test:**

Bidder to conduct performance test as per applicable test standard as a minimum. Performance test procedure to be furnished for BHEL approval prior to testing. Following performance tests as a minimum to be covered:

- a) Flow Rate Check at Outlet
- b) Static Pressure Check at outlet
- c) Blower fan vibration test
- d) A mechanical & Electrical function test. Electrical System will be tested on its applicable standard & approved.

**9. PAINTING:**

The Blowers and other items shall be epoxy painted. Bidder to furnish the painting procedure for approval after award of contract. One coat of zinc rich epoxy primer of DFT 75 micron shall be applied along with two coats of epoxy paint DFT 40 micron and DFT 30 micron respectively. This is the preliminary requirement. Painting procedure shall be submitted by bidder/ vendor for BHEL review after award of order. The same can be discussed & finalized in detail during detail engineering stage.

**10. PACKING AND FORWARDING:**

Bidder to note that Packing and Forwarding shall be as per manufacturing standard and however, bidder shall duly take care of requirement mentioned in Specification for Packing & Forwarding (Annexure-5). Packing shall be suitable for outdoor storage of 12 months at site. If any extra precaution is to be taken by the purchaser for storage beyond 12 months, the same shall be explicitly indicated in the Operation & Maintenance manual.

**11. SUB VENDORS:**

Bidder shall follow sub vendors list enclosed as Annexure-8. In case of any specific practical difficulty, bidder is requested to bring out the same with proper reason for not following vendor list. For other items for which sub vendors are not specified, bidder can follow their standard vendors. However, they have to ensure the Proven Track record of the sub vendors and Bidder to take prior approval of BHEL for the same.

**12. DOCUMENTATION:**

Please refer to enclosed Master Documentation List [MDL] (Annexure-9) for the list of DOCUMENTS / DRAWINGS to be submitted by the bidder as part of documentation. Bidder shall ensure submission of all documentation as per this Annexure.

Bidder to note that the dates of submission of all the documents shall be finalized based on PO date. It shall be solely bidder's responsibility to get approval on the entire document from purchaser to meet project schedule.

**A. DEFINITION OF VENDOR DOCUMENT REVIEW STATUS ASSIGNED BY BHEL**

The guidelines listed below are followed in assigning the document status code to the vendor documents: Final submittal of vendor documents will not be required as long as the document status code is 1 or 4 and the "AS-BUILT" condition of the component agrees with the current document.

Permission to proceed does not constitute acceptance or approval of design details, calculations, analyses, test methods, or materials developed or selected by the vendor and does not relieve the vendor from full compliance with contractual obligations.

**Code-1: Work may proceed**



The document conforms to procurement document requirements. The document requires no changes or additions. Matters remaining to be resolved do not require document change and will be handled by correspondence. Where it is known that the design information on a vendor document is not complete and re-submittals will be required, e.g., due to "hold" areas, the document is assigned another status code.

**Code-2: Revise and resubmit**

Work may proceed subject to resolution of indicated comments. The document is in basic conformance with procurement document requirements. Minor deviations from procurement document requirements have been noted or other minor technical or physical changes in the equipment are required. The vendor shall resolve comments and resubmit documents prior to shipment of commodity.

**Code-3: Rejected. Revise and resubmit**

The document:

- i. Does not conform to the procurement requirements,
- ii. Is of a design that is technically unacceptable without significant changes,
- iii. Does not meet project requirements, i.e., orientation of equipment, nozzles, conduit connections, etc.,
- iv. Does not conform to project criteria or with proposal documents or data, or
- v. Does not meet minimum submittal requirements.

This submittal rejection does not relieve vendor of any schedule commitments.

**Code-4: Review not required**

The document is not subject to BHEL review. Typical uses for this status are in the review of items that are vendor standard products, small internal parts of major equipment, or vendor standardized data.

**B. DRAWINGS REVIEW & APPROVALS:**

Each drawing submitted by the bidder shall be with a title block furnished by BHEL during detailed engg stage.

All drawings / documents shall be thoroughly checked, duly signed, and stamped by the vendor including drawing /documents of sub-vendor, before submission to BHEL. Documents, which are unchecked, unsigned, and without revisions marked clearly, shall be returned without review. Any delay on account of this shall be to the vendor's account. After first review of documents, vendor to submit all the further revisions of documents along with comment resolution sheet. Successive documents submitted without comment resolution sheet shall be returned without review.

The approval and /or review by BHEL /End customer shall not be construed by the bidder as limiting any of his responsibilities and liabilities for mistakes and deviations from the requirements, specified under these specifications and drawings.



Documents once reviewed in Code-1 shall not be submitted (incorporating some changes) again for review, however if some change is really necessary, the same shall be brought to the notice of BHEL separately through design change note for review / information. Finally, As -built drawings, duly updated, shall be submitted.

During detailed engg stage, BHEL shall furnish check list reg minimum contents in GA drawing. Bidder to submit GAD [duly incorporating all requirements as per the check list] along with signed checklist. GAD shall not be reviewed without duly filled in checklist signed by the bidder.

### C. NO. OF COPIES OF EACH DOCUMENT TO BE FURNISHED:

**All the documents shall be submitted as given below:**

SL NO.	DESCRIPTION	NO. OF COPIES / PIECES TO BE SUBMITTED	WHEN TO SUBMIT
	Schedule of Document Submission (indicating plan of submission date of each document)	Soft Copy only	Within 3 days of placement of order
1)	Initial drawings/documents under approval and information category.	Soft copy only	Within 2 weeks of placement of order
2)	BHEL shall furnish their observation on submitted documents	Soft copy only	Within 2 weeks of document submission
3)	*Revised drawings/documents along with compliance sheet incorporating all BHEL comments.  <i>*Vendor to incorporate all BHEL comments so that further revisions can be minimized.</i>	Soft copy only	Within 1 weeks of receipt of commented Drawings from BHEL
4)	BHEL shall furnish their observation on submitted documents	Soft copy only	Within 2 weeks of document submission
5)	Final Drawings/documents	12	Within 2 months of placement of order.
6)	Erection Documentation	5	1 month before dispatch of equipment. The list of documents identified under master document list for



			erection to be furnished in 5 no's of folders
7)	Draft O & M Manuals for BHEL review.  <i>Note: Bidder to furnish final hard copy of O&amp;M only after getting concurrence on soft copy.</i>	Soft copy	At least 2 months before the delivery date of equipment
8)	Revised O & M Manuals with Test Certificates to be submitted to BHEL (Hyderabad)	12	Within one month before the delivery date of equipment
9)	Final O&M manuals in a CD	4	Within one month after dispatch of equipment after BHEL concurrence on soft copy.

**NOTES:**

1) The O&M manuals shall contain the following as minimum:

- The identification details of the equipment like BHEL P.O. No., Vendor's Job Identification No., full contact address with telephone, fax, & e-mail details.
- Brief description of the system.
- All approved documents [ Drawings, documents & test procedures as per MDL]
- Bill of material, BBU, LO schedule, sub vendor list, Mandatory & commissioning spares list etc.
- Operation, Instruction & maintenance manuals of all equipments / items fo the complete package
- System unloading, storage erection, start up, commissioning, shut down requirements.
- Operational & environmental safety instructions.
- Test reports and certificates.
- Catalogues of the equipment & instrumentation.

**CONFLICTS IN SPECIFICATION REQUIREMENTS:**

In case of any conflict between this specification and Annexures, the stringent of the both shall be considered or the same shall be brought to the notice of the purchaser for suitable clarification.

**13. PRICE BID FORMAT:**

Bidder to indicate his offer as per Price Bid format enclosed as Annexure-3.

All the items included in the price bid format shall be quoted as per tender specification and pre-bid clarifications as per annexure-11, if any. Responsibility of ensuring correctness & completeness of scope of supply as per specification requirement solely lies with bidder.



The equipment supplied shall be complete in all respects. The bidder shall not be eligible for any extra payment in respect of such mountings, fittings, fixtures and accessories if required for the safe and reliable operation of the equipment. Any additional equipment, material, etc., which are not specifically mentioned here, but are required to make the supplied equipment complete in all respect, in accordance with the intent of this technical specification, contractual agreement, statutory requirements, relevant/applicable codes/standards, good engineering practices, and for safe and trouble-free operation, shall be deemed to be in bidder scope Only.

Main offer consists of those items, which will be part of main order after successful bidder is identified. Optional Items consists of those items, which need to be quoted by bidder but may or may not be ordered by BHEL. Bidders are instructed to provide the pricing details listed under Main offer and Optional items as per the prescribed format. Prices quoted by the bidder shall remain firm till the successful handing over of the entire package to end customer. Any request for upward revision of price during any intermediate stage before handing over the plant to end customer will be summarily rejected by BHEL.

The Priced Bid shall be submitted in Original (without any copy) duly signed and stamped on each page in a separate sealed envelope super scribing "Price Bid –Do not Open" This shall not contain any condition whatsoever failing which the Bids shall be liable to be rejected. In case of any correction, the bidder shall put its signature and its stamp. Eraser fluid will not be allowed for making any correction.

Bidder shall confirm to the un-priced bid as part of their offer.

#### 14. PRE-BID CLARIFICATIONS

- 14.1 Bidders shall comply with various requirements of this specification. It may please be noted that the requirements specified here in this specification are the standard practices being followed by the bidders. However, same things are presented in a structured form so that it can be ensured that the requirements of ultimate customer are complied with.
- 14.2 Bidders can bring out only those deviations which are impractical to meet, for our review in pre bid clarification only.
- 14.3 Bidders may also please note that the data sheets for, valves, instruments etc., submitted along with the offer will be considered as indicative only, as the requirements specified in the specification are standard in nature. These will not be reviewed by BHEL before award of contract. Same will be reviewed during order execution stage in line with the requirements of specification and agreed deviations.
- 14.4 All pre-bid clarifications & deviation shall be clearly indicated in the enclosed Annexure-11 and 10 only.
- 14.5 In case bidder doesn't bring any clarification/deviation in pre-bid stage, the same shall be brought in their offer with following conditions:
  - a. Any deviations to Customer specifications, same are acceptable provided these deviations are also regularly accepted by Customer for their direct orders on bidders. During detailed engineering stage if it is found that any deviation brought out by bidder is not a regular deviation accepted by Customer, the particular deviation brought out by bidder will not be considered as an acceptable deviation.



- b. Bidders may please note that unless the deviations are specifically brought out under deviations clause (in the prescribed format as per Annexure-10), it will be considered that no deviations are taken, even if they are mentioned elsewhere directly/indirectly in the offer.
- c. Price implication due to non-acceptance [by BHEL/Customer] of the deviations asked by bidder, shall not be acceptable by BHEL.

**VARIANT TABLE:**

Sl. No.	Variant No.	Item	Material Code	Project
1	1	Centrifugal Air Blower for Bio Filter-Main Supply	PY9751444012	7.40 MLD STP at sector - 1
2	5	Centrifugal Air Blower for Bio Filter-Supply	PY9751444055	4.33 MLD STP at sector – 6
3	9	Centrifugal Air Blower for Bio Filter-Supply	PY9751444098	7.05 MLD STP at sector– 12
4	13	Centrifugal Air Blower for Bio Filter-Supply	PY9751444136	1.79 MLD STP at sector-11 a
5	26	Centrifugal Air Blower for Bio Filter-Supply	PY9751444268	0.872MLD STP at sector11 b
6	21	Centrifugal Air Blower for Bio Filter-Supply	PY9751444217	3.98 MLD STP at sector11 b
7	25	Supervision of E&C of Centrifugal Air Blower	PY9851444251	Any of the Above 6 Mentioned project



ESP-001-  
2A Rev.00



**PROJECT ENGINEERING & SYSTEMS DIVISION**

Std. / Doc. Number

Annexure-1

Rev. No. 00

**COPYRIGHT AND CONFIDENTIAL**

The information on this document is the property of **BHARAT HEAVY ELECTRICALS LIMITED**,  
It must not be used directly or indirectly in any way detrimental to the interest of the company.

# Annexure-1

## P&IDs

**Revisions:**  
Refer to record of revisions

No.	Description	By	Date

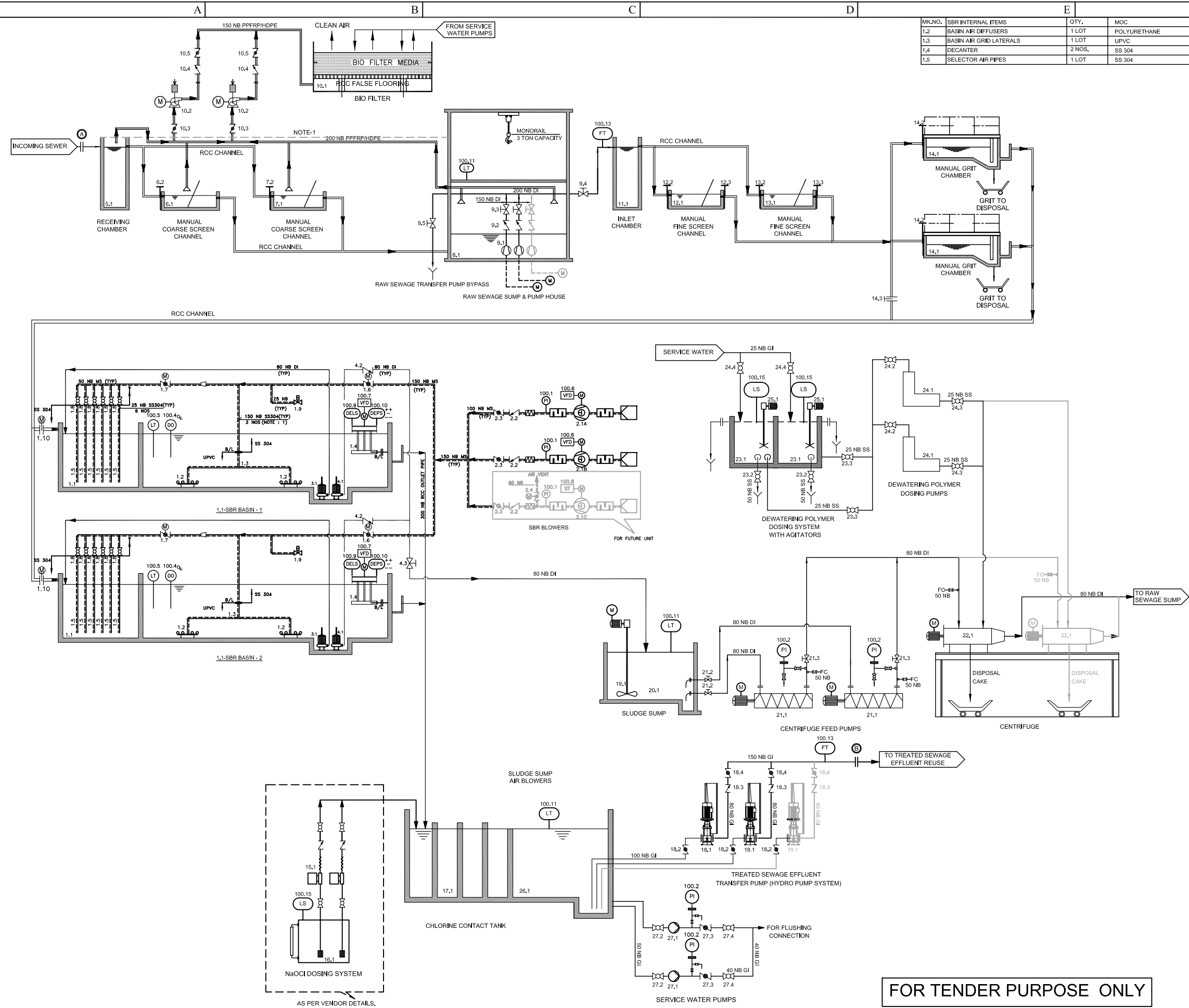

MK.NO.	SBR INTERNAL ITEMS	QTY.	MOC
1.2	Basin Air Diffusers	1 LOT	POLYURETHANE
1.3	Basin Air Grid Laterals	1 LOT	UPVC
1.4	Decanter	2 NOS.	SS 304
1.5	Selector Air Pipes	1 LOT	SS 304

MK. NO.	DESCRIPTION	SIZE/CAPACITY	QTY	REMARK
1.1	SBR BASINS - 1/2	16700 x 8400 x 5200 SWD.	02	RCC
2.1	SBR AIR BLOWERS	500 Nm <sup>3</sup> /hr. @ 0.62 kg/cm <sup>2</sup>	03	2W + 1S
3.1	RETURN ACTIVATED SLUDGE PUMPS	20 m <sup>3</sup> /hr. @ 5 MWC	02	2W
4.1	SURPLUS ACTIVATED SLUDGE PUMPS	15 m <sup>3</sup> /hr. @ 10 MWC	02	2W
5.1	RECEIVING CHAMBER	1100 x 1200 x 1500 SWD.	01	RCC
6.1	MANUAL COARSE SCREEN	3000 x 400 x 400 SWD.	01	RCC
7.1	MANUAL COARSE SCREEN	3000 x 400 x 400 SWD.	01	RCC
8.1	RAW SEWAGE SUMP	4000 Ø x 1500 SWD.	01	RCC
9.1	RAW WATER TRANSFER PUMPS	112 m <sup>3</sup> /hr. @ 15 MWC	03	2W+1S
10.1	BIO FILTER	4000 x 1500	01	RCC
10.2	CENTRIFUGAL BLOWERS FOR BIO-FILTER	1200 m <sup>3</sup> /hr. @ 0.2 MWC	02	1W+1S
11.1	INLET CHAMBER	1200 x 1200 x 1500 SWD.	01	RCC
12.1	MANUAL FINE SCREEN	3500 x 400 x 400 SWD.	01	RCC
13.1	MANUAL FINE SCREEN	3500 x 400 x 400 SWD.	01	RCC
14.1	MANUAL GRIT CHAMBER	6000 x 1000 x 900 SWD.	02	RCC
15.1	NaOCl DOSING PUMPS	15 LPH	02	1W + 1S
16.1	NaOCl DOSING TANK	100 Ltr.	01	1W
17.1	CHLORINATION TANK CUM TREATED WATER TANK	7500 x 4000 x 2500 SWD.	01	RCC
18.1	TREATED WATER TRANSFER PUMP	40.3 @ 45 MWC	03	2W + 1S
19.1	SLUDGE SUMP AGITATOR	2 HP @ 100 RPM	01	1W
20.1	SLUDGE SUMP	2000 x 2200 x 2500 SWD.	01	RCC
21.1	CENTRIFUGE FEED PUMPS	3 m <sup>3</sup> /hr. @ 15 MWC	02	1W + 1S
22.1	CENTRIFUGE	3 m <sup>3</sup> /hr.	02	1W + 1S
23.1	POLYELECTROLYTE DOSING TANK	300 Ltr.	02	RCC
24.1	POLYELECTROLYTE DOSING PUMPS	60 LPH @ 4.0 kg/cm <sup>2</sup>	02	2W
25.1	POLYELECTROLYTE DOSING TANK AGITATOR	0.5 HP @ 100 RPM	02	2W
26.1	TREATED SEWAGE EFFLUENT TANK	4000 x 2500 x 4000 SWD.	01	RCC
27.1	SERVICE WATER PUMPS	5 m <sup>3</sup> /hr. @ 25 MWC	02	1W + 1S

MK.NO.	DESCRIPTION	SIZE	QTY	TYPE	OPERATION
1.6	SBR MAIN AIR LINE	ISOLATION 150 NB	02	BUTTERFLY	MOTORIZED
1.7	SELECTOR MAIN AIR LINE	ISOLATION 50 NB	02	BUTTERFLY	MOTORIZED
1.8	SELECTOR AIR GRID LINE	ISOLATION 25 NB	12	BALL	MANUAL
1.9	SBR AIR HEADER	AIR VENT 25 NB	02	SOLENOID	ELECTRICAL
1.10	SBR INLET	ISOLATION 350x400	02	SLUICE GATE	MOTORIZED
2.2	SBR AIR BLOWERS	NON-RETURN 100 NB	03	SWING CHECK	MANUAL
2.3	SBR AIR BLOWERS	DISCHARGE 100 NB	03	BUTTERFLY	MANUAL
4.2	SAS PUMP	DISCHARGE 80 NB	02	DUAL PLATE CHECK	MANUAL
4.3	SAS PUMP	HEADER 80 NB	01	KNIFE GATE	MANUAL
6.2	MANUAL BAR SCREEN (COARSE)	ISOLATION 400x700	01	SLUICE GATE	MANUAL
7.2	MANUAL BAR SCREEN (COARSE)	ISOLATION 400x700	01	SLUICE GATE	MANUAL
9.2	RAW SEWAGE TRANSFER PUMP	NON RETURN 150 NB	03	SWING CHECK	-
9.3	RAW SEWAGE TRANSFER PUMP	DISCHARGE 150 NB	03	KNIFE GATE	MANUAL
9.4	RAW SEWAGE TRANSFER PUMP	DISCHARGE 200 NB	01	KNIFE GATE	MANUAL
9.5	RAW SEWAGE TRANSFER PUMP	BYPASS 200 NB	01	KNIFE GATE	MANUAL
10.3	BIO FILTER BLOWER	ISOLATION 200 NB	02	BUTTERFLY	MANUAL
10.4	BIO FILTER BLOWER	DISCHARGE 150 NB	02	SWING CHECK	MANUAL
10.5	BIO FILTER BLOWER	DISCHARGE 150 NB	02	BUTTERFLY	MANUAL
12.2	MANUAL BAR SCREEN (FINE)	ISOLATION 400x700	01	SLUICE GATE	MANUAL
12.3	MANUAL BAR SCREEN (FINE)	ISOLATION 400x700	01	SLUICE GATE	MANUAL
13.2	MANUAL BAR SCREEN (FINE)	ISOLATION 400x700	01	SLUICE GATE	MANUAL
13.3	MANUAL BAR SCREEN (FINE)	ISOLATION 400x700	01	SLUICE GATE	MANUAL
14.2	GRIT CHAMBER	ISOLATION 350x400	02	SLUICE GATE	MANUAL
14.3	GRIT CHAMBER	BYPASS 350x400	01	SLUICE GATE	MANUAL
18.2	TREATED WATER TRANSFER PUMP	ISOLATION 100 NB	03	BUTTERFLY	MANUAL
18.3	TREATED WATER TRANSFER PUMP	SUCTION 80 NB	03	SWING CHECK	-
18.4	TREATED WATER TRANSFER PUMP	DISCHARGE 80 NB	03	BUTTERFLY	MANUAL
21.2	CENTRIFUGE FEED PUMPS	SUCTION 80 NB	02	KNIFE GATE	MANUAL
21.3	CENTRIFUGE FEED PUMPS	DISCHARGE 80 NB	02	KNIFE GATE	MANUAL
23.2	DWPE TANK	DRAIN 50 NB	02	BALL	MANUAL
23.3	DWPE TANK	OUTLET 25 NB	02	BALL	MANUAL
24.2	DWPE DOSING PUMPS	SUCTION 25 NB	02	BALL	MANUAL
24.3	DWPE DOSING PUMPS	DISCHARGE 25 NB	02	BALL	MANUAL
24.4	SERVICE WATER PUMPS	INLET 25 NB	02	BALL	MANUAL
27.2	SERVICE WATER PUMPS	SUCTION 50 NB	02	BALL	MANUAL
27.3	SERVICE WATER PUMPS	DISCHARGE 40 NB	02	BUTTERFLY	MANUAL
27.4	SERVICE WATER PUMPS	DISCHARGE 40 NB	02	BALL	MANUAL

LINE LEGEND	INSTRUMENT LIST
--- RAS LINE	MK.NO. DESCRIPTION REMARK
--- SAS LINE	PI 100.1 PRESSURE GAUGES BOURDON TYPE
--- AIR LINE	PI 100.2 PRESSURE GAUGES DIAPHRAGM TYPE
--- INSTRUMENT SIGNAL	DO 100.4 DISSOLVED OXYGEN METER IMMERSION TYPE
--- DRAIN LINE	LT 100.5 LEVEL TRANSMITTER HYDROSTATIC TYPE
--- RCC CHANNEL	LT 100.11 LEVEL TRANSMITTER ULTRASONIC TYPE
--- LEGEND	LT 100.12 LEVEL TRANSMITTER DIFFERENTIAL ULTRASONIC TYPE
--- NON-RETURN VALVE	DLT 100.13 LEVEL TRANSMITTER DIFFERENTIAL ULTRASONIC TYPE
--- BUTTERFLY VALVE	LS 100.15 LEVEL SWITCH CAPACITANCE TYPE
--- MOTORISED KNIFE GATE VALVE	FT 100.13 FLOW METER ULTRASONIC TYPE
--- MOTORISED BUTTERFLY VALVE	
--- CHANNEL MOUNTED MOTORISED GATE	
--- KNIFE GATE VALVE	
--- BALL VALVE	
--- VARIABLE FREQUENCY DRIVE	
--- SOFT STARTER	
--- MOTOR	
--- AIR BLOWER	
--- SILENCER	
--- FILTER	

NOTE:-  
 1. ALL UNITS IN RAW SEWAGE PUMPING STATION SHALL BE COVERED WITH FRP SHEET SUPPORTED BY STRUCTURAL STEEL WITH ANTI-CORROSIVE TREATMENT.  
 2. THIS P&ID INDICATES EQUIPMENTS FOR PRESENT + FUTURE

**FOR TENDER PURPOSE ONLY**

PROJECT: 1.79 MLD SEWAGE TREATMENT PLANT  
 BASED ON SBR AT SECTOR-11a KAMAL VIHAR, RAIPUR  
 TITLE: PIPING & INSTRUMENTATION DIAGRAM

REV.NO	REVISIONS	DRAWN	CHECKED	APPROVED	DATE	REFERENCE DRAWING NO.	REFERENCE DRAWING NAME	SCALE	NTS	PROJECTION	DATE	BY	SIGN
											24-01-2017		
											24-01-2017		
											24-01-2017		
											24-01-2017		

CONT. CODE	DWG. SIZE	DWG. NO.	REV.
-	A2	A2/1.79MLD/101/01	R1



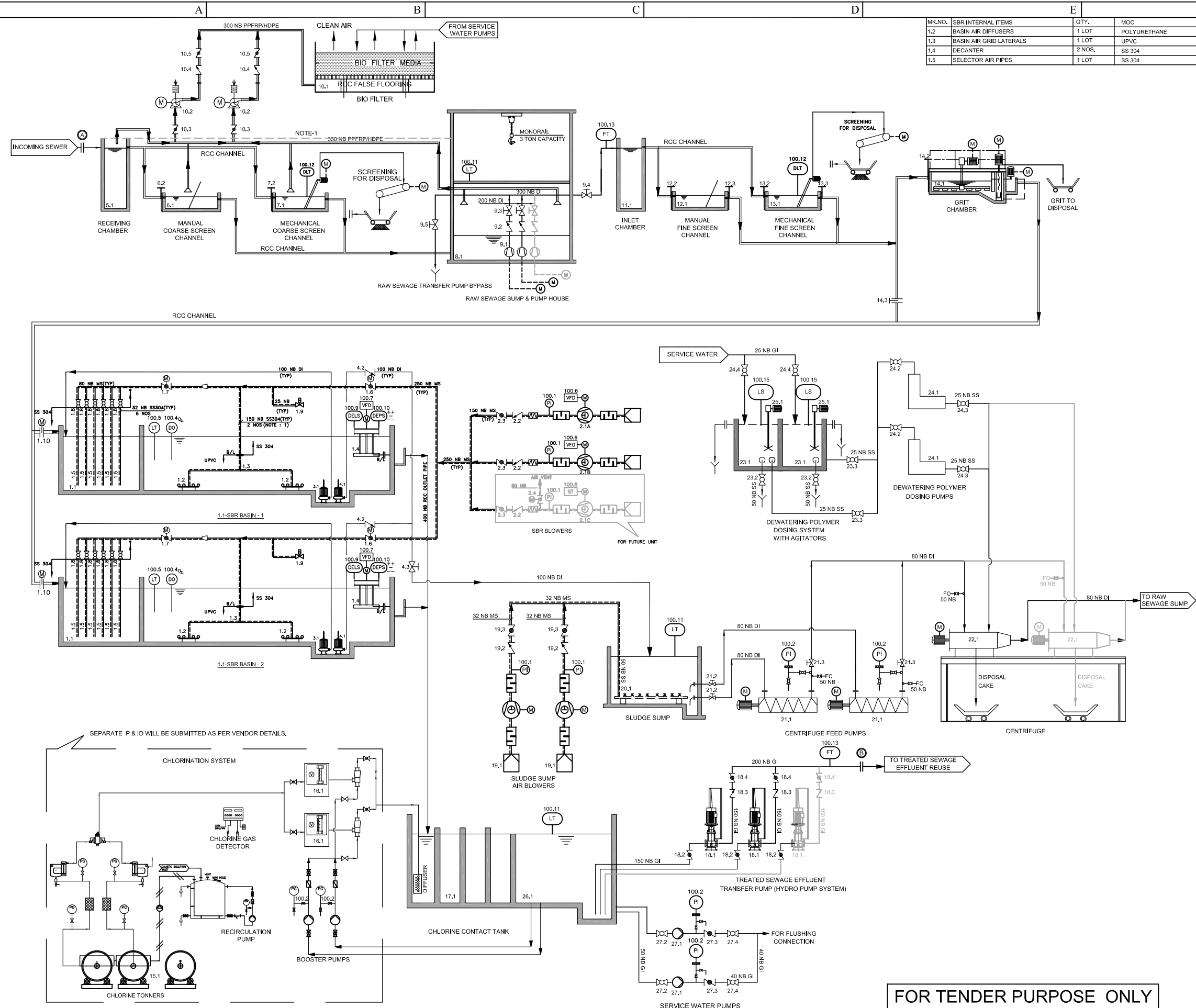

MK.NO.	SBR INTERNAL ITEMS	QTY.	MOC
1.2	Basin Air Diffusers	1 LOT	POLYURETHANE
1.3	Basin Air Grid Laterals	1 LOT	UPVC
1.4	Decanter	2 NOS.	SS 304
1.5	Selector Air Pipes	1 LOT	SS 304

MK.NO.	DESCRIPTION	SIZE/CAPACITY	QTY	REMARK
1.1	SBR Basins - 1/2	24200 x 12200 x 5200 SWD.	02	RCC
2.1	SBR Air Blowers	1100 Nm <sup>3</sup> /hr. @ 0.62 kg/cm <sup>2</sup>	03	2W + 1S
3.1	Return Activated Sludge Pumps	50 m <sup>3</sup> /hr. @ 5 MWC	02	2W
4.1	Surplus Activated Sludge Pumps	30 m <sup>3</sup> /hr. @ 10 MWC	02	2W
5.1	Receiving Chamber	2000 x 1600 x 1500 SWD.	01	RCC
6.1	Manual Coarse Screen	3000 x 650 x 550 SWD.	01	RCC
7.1	Mechanical Coarse Screen	3000 x 650 x 550 SWD.	01	RCC
8.1	Raw Sewage Sump	6000 Ø x 1500 SWD.	01	RCC
9.1	Raw Water Transfer Pumps	230 m <sup>3</sup> /hr. @ 15 MWC	03	2W+1S
10.1	Bio Filter	6000 x 3000	01	RCC
10.2	Centrifugal Blowers for Bio-Filter	4900 m <sup>3</sup> /hr. @ 0.2 MWC	02	1W+1S
11.1	Inlet Chamber	1600 x 1600 x 1500 SWD.	01	RCC
12.1	Manual Fine Screen	3500 x 700 x 500 SWD.	01	RCC
13.1	Mechanical Fine Screen	3500 x 700 x 500 SWD.	01	RCC
14.1	Grit Chamber	3500 x 3500 x 900 SWD.	01	RCC
15.1	Chlorin Tonners	928 kg	02	1W + 1S
16.1	Chlorinators	2 kg/hr	02	1W + 1S
17.1	Chlorination Tank cum Treated Water Tank	12500 x 5000 x 3000 SWD.	01	RCC
18.1	Treated Water Transfer Pump	97.40 @ 45 MWC	03	2W + 1S
19.1	Sludge Sump Air Blowers	40 m <sup>3</sup> /hr. @ 0.35 kg/cm <sup>2</sup>	02	1W + 1S
20.1	Sludge Sump	5000 x 1900 x 3000 SWD.	01	RCC
21.1	Centrifuge Feed Pumps	6 m <sup>3</sup> /hr. @ 15 MWC	02	1W + 1S
22.1	Centrifuge	6 m <sup>3</sup> /hr.	02	1W + 1S
23.1	Polyelectrolyte Dosing Tank	1200 x 1200 x 1500 SWD.	02	RCC
24.1	Polyelectrolyte Dosing Pumps	140 LPH @ 4.0 kg/cm <sup>2</sup>	02	2W
25.1	Polyelectrolyte Dosing Tank Agitator	1 HP @ 100 RPM	02	2W
26.1	Treated Sewage Effluent Tank	5000 x 4000 x 5000 SWD.	01	RCC
27.1	Service Water Pumps	5 m <sup>3</sup> /hr. @ 25 MWC	02	1W + 1S

MK.NO.	DESCRIPTION	SIZE	QTY	TYPE	OPERATION
1.6	SBR Main Air Line	ISOLATION 250 NB	02	BUTTERFLY	MOTORIZED
1.7	Selector Main Air Line	ISOLATION 80 NB	02	BUTTERFLY	MOTORIZED
1.8	Selector Air Grid Line	ISOLATION 32 NB	12	BALL	MANUAL
1.9	SBR Air Header	AIR VENT 25 NB	02	SOLENOID	ELECTRICAL
1.10	SBR Inlet	ISOLATION 400x500	02	SLUICE GATE	MOTORIZED
2.2	SBR Air Blowers	NON-RETURN 150 NB	03	SWING CHECK	MANUAL
2.3	SBR Air Blowers	DISCHARGE 150 NB	03	BUTTERFLY	MANUAL
4.2	SAS Pump	DISCHARGE 100 NB	02	DUAL PLATE CHECK	MANUAL
4.3	SAS Pump	HEADER 100 NB	01	KNIFE GATE	MANUAL
6.2	Manual Bar Screen (Coarse)	ISOLATION 650x850	01	SLUICE GATE	MANUAL
7.2	Mechanical Bar Screen (Coarse)	ISOLATION 650x850	01	SLUICE GATE	MANUAL
9.2	Raw Sewage Transfer Pump	NON RETURN 200 NB	03	SWING CHECK	-
9.3	Raw Sewage Transfer Pump	DISCHARGE 200 NB	03	KNIFE GATE	MANUAL
9.4	Raw Sewage Transfer Pump	DISCHARGE 350 NB	01	KNIFE GATE	MANUAL
9.5	Raw Sewage Transfer Pump	BYPASS 50 NB	01	KNIFE GATE	MANUAL
10.3	Bio Filter Blower	ISOLATION 300 NB	02	BUTTERFLY	MANUAL
10.4	Bio Filter Blower	DISCHARGE 300 NB	02	SWING CHECK	MANUAL
10.5	Bio Filter Blower	DISCHARGE 300 NB	02	BUTTERFLY	MANUAL
12.2	Manual Bar Screen (Fine)	ISOLATION 700x800	01	SLUICE GATE	MANUAL
12.3	Manual Bar Screen (Fine)	ISOLATION 700x800	01	SLUICE GATE	MANUAL
13.2	Mechanical Bar Screen (Fine)	ISOLATION 700x800	01	SLUICE GATE	MANUAL
13.3	Mechanical Bar Screen (Fine)	ISOLATION 700x800	01	SLUICE GATE	MANUAL
14.2	Grit Chamber	ISOLATION 400x500	01	SLUICE GATE	MANUAL
14.3	Grit Chamber	BYPASS 400x500	01	SLUICE GATE	MANUAL
18.2	Treated Water Transfer Pump	ISOLATION 150 NB	03	BUTTERFLY	MANUAL
18.3	Treated Water Transfer Pump	SUCTION 150 NB	03	SWING CHECK	-
18.4	Treated Water Transfer Pump	DISCHARGE 150 NB	03	BUTTERFLY	MANUAL
19.2	Sludge Sump Air Blower	NON RETURN 32 NB	02	SWING CHECK	-
19.3	Sludge Sump Air Blower	DISCHARGE 32 NB	02	BUTTERFLY	MANUAL
21.2	Centrifuge Feed Pumps	SUCTION 80 NB	02	KNIFE GATE	MANUAL
21.3	Centrifuge Feed Pumps	DISCHARGE 80 NB	02	KNIFE GATE	MANUAL
23.2	DWPE Tank	DRAIN 50 NB	02	BALL	MANUAL
23.3	DWPE Tank	OUTLET 25 NB	02	BALL	MANUAL
24.2	DWPE Dosing Pumps	SUCTION 25 NB	02	BALL	MANUAL
24.3	DWPE Dosing Pumps	DISCHARGE 25 NB	02	BALL	MANUAL
24.4	Service Water Pumps	INLET 25 NB	02	BALL	MANUAL
27.2	Service Water Pumps	SUCTION 50 NB	02	BALL	MANUAL
27.3	Service Water Pumps	DISCHARGE 40 NB	02	BUTTERFLY	MANUAL
27.4	Service Water Pumps	DISCHARGE 40 NB	02	BALL	MANUAL

LINE LEGEND	INSTRUMENT LIST
--- RAS LINE	MK.NO. DESCRIPTION REMARK
--- SAS LINE	PI 100.1 PRESSURE GAUGES BOURDON TYPE
--- AIR LINE	PI 100.2 PRESSURE GAUGES DIAPHRAGM TYPE
--- INSTRUMENT SIGNAL	DO 100.4 DISSOLVED OXYGEN METER IMMERSION TYPE
--- DRAIN LINE	LT 100.5 LEVEL TRANSMITTER HYDROSTATIC TYPE
--- RCC CHANNEL	VFD 100.6 VARIABLE FREQUENCY DRIVE FOR BLOWERS
--- LEGEND	VFD 100.7 VARIABLE FREQUENCY DRIVE FOR DECATERS
--- (NON-RETURN VALVE)	ST 100.8 SOFT STARTER FOR BLOWER
--- (BUTTERFLY VALVE)	DELS100.9 DECATER LEVEL SENSOR CAPACITIVE TYPE
--- (MOTORISED KNIFE GATE VALVE)	DEPS100.10 DECATER POSITION SENSOR MAGNETIC LIMIT SWITCH
--- (MOTORISED BUTTERFLY VALVE)	LT 100.11 LEVEL TRANSMITTER ULTRASONIC TYPE
--- (KNIFE GATE VALVE)	LT 100.12 LEVEL TRANSMITTER DIFFERENTIAL ULTRASONIC TYPE
--- (BALL VALVE)	LS 100.15 LEVEL SWITCH CAPACITIVE TYPE
--- (VARIABLE FREQUENCY DRIVE)	FT 100.13 FLOW METER ULTRASONIC TYPE
--- (SOFT STARTER)	
--- (MOTOR)	
--- (AIR BLOWER)	
--- (SILENCER)	
--- (FILTER)	

NOTE:-  
 1. ALL UNITS IN RAW SEWAGE PUMPING STATION SHALL BE COVERED WITH FRP SHEET SUPPORTED BY STRUCTURAL STEEL WITH ANTI-CORROSIVE TREATMENT.  
 2. THIS P&ID INDICATES EQUIPMENTS FOR PRESENT + FUTURE

FOR TENDER PURPOSE ONLY

PROJECT: 4.33 MLD SEWAGE TREATMENT PLANT  
 BASED ON SBR AT SECTOR-6 KAMAL VIHAR, RAIPUR  
 TITLE: PIPING & INSTRUMENTATION DIAGRAM

REV.NO	REVISIONS	DRAWN	CHECKED	APPROVED	DATE	REFERENCE DRAWING NO.	REFERENCE DRAWING NAME	SCALE	NTS	PROJECTION

CONT. CODE	DWG. SIZE	DWG. NO.	REV.
-	A2	A2/4.33MLD/101/01	R1

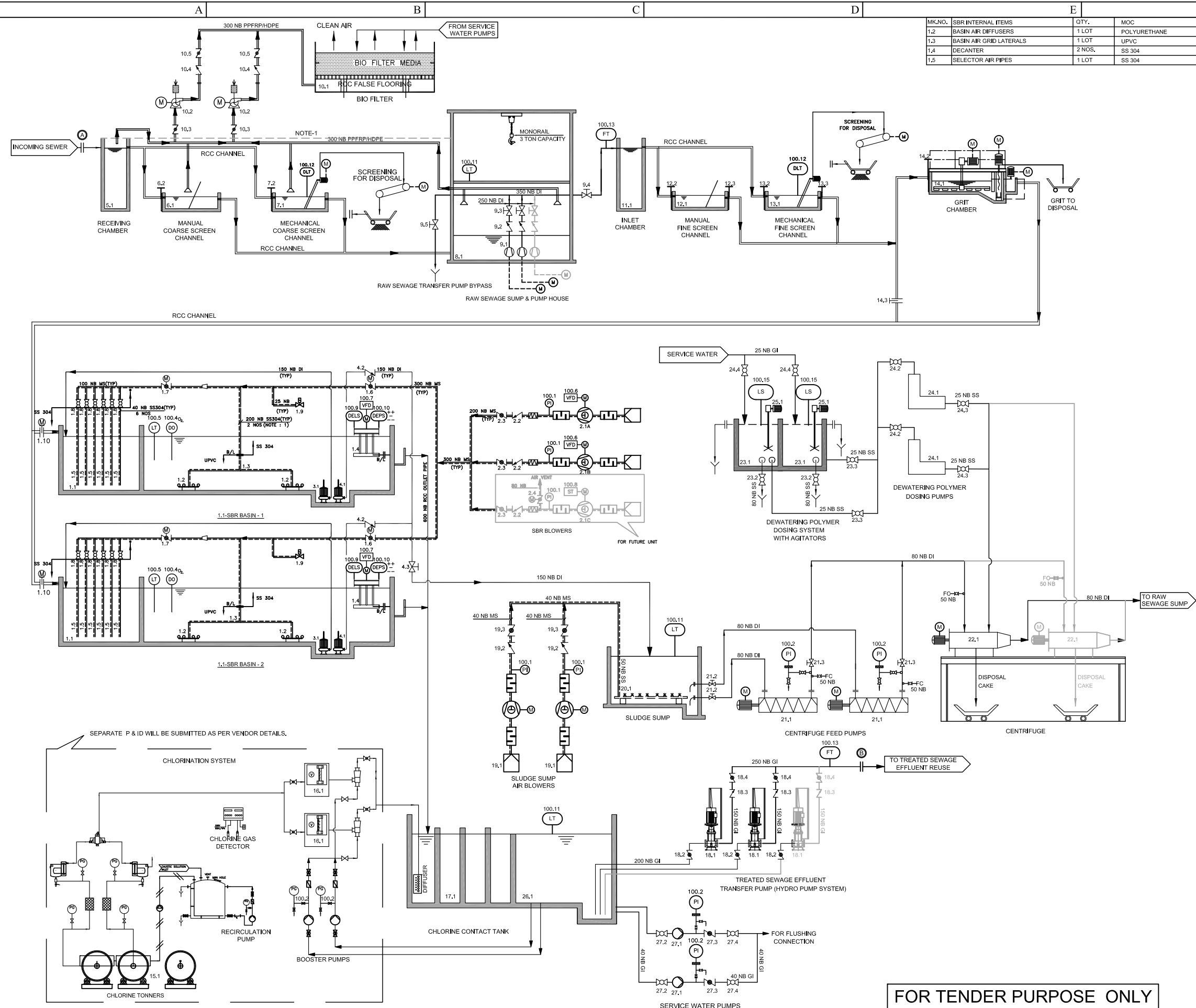

MK.NO.	SBR INTERNAL ITEMS	QTY.	MOC
1.2	Basin Air Diffusers	1 LOT	POLYURETHANE
1.3	Basin Air Grid Laterals	1 LOT	UPVC
1.4	Decanter	2 NOS.	SS 304
1.5	Selector Air Pipes	1 LOT	SS 304

MK.NO.	DESCRIPTION	SIZE/CAPACITY	QTY	REMARK
1.1	SBR Basins - 1/2	29400 x 14700 x 5200 SWD.	02	RCC
2.1	SBR Air Blowers	1700 Nm <sup>3</sup> /hr. @ 0.62 kg/cm <sup>2</sup>	03	2W + 1S
3.1	Return Activated Sludge Pumps	75 m <sup>3</sup> /hr. @ 5 MWC	02	2W
4.1	Surplus Activated Sludge Pumps	50 m <sup>3</sup> /hr. @ 10 MWC	02	2W
5.1	Receiving Chamber	2000 x 2000 x 1500 SWD.	01	RCC
6.1	Manual Coarse Screen	3500 x 700 x 650 SWD.	01	RCC
7.1	Mechanical Coarse Screen	3500 x 700 x 650 SWD.	01	RCC
8.1	Raw Sewage Sump	6000 Ø x 2000 SWD.	01	RCC
9.1	Raw Water Transfer Pumps	335 m <sup>3</sup> /hr. @ 15 MWC	03	2W+1S
10.1	Bio Filter	6000 x 3000	01	RCC
10.2	Centrifugal Blowers for Bio-Filter	4500 m <sup>3</sup> /hr. @ 0.2 MWC	02	1W+1S
11.1	Inlet Chamber	1500 x 2000 x 2000 SWD.	01	RCC
12.1	Manual Fine Screen	5000 x 700 x 700 SWD.	01	RCC
13.1	Mechanical Fine Screen	5000 x 700 x 700 SWD.	01	RCC
14.1	Grit Chamber	4500 x 4500 x 800 SWD.	01	RCC
15.1	Chlorin Tonners	928 kg	02	1W + 1S
16.1	Chlorinators	3 kg/hr	02	1W + 1S
17.1	Chlorination Tank cum Treated Water Tank	16000 x 7500 x 2500 SWD.	01	RCC
18.1	Treated Water Transfer Pump	158.80 @ 45 MWC	03	2W + 1S
19.1	Sludge Sump Air Blowers	70 m <sup>3</sup> /hr. @ 0.4 kg/cm <sup>2</sup>	02	1W + 1S
20.1	Sludge Sump	7000 x 2500 x 3000 SWD.	01	RCC
21.1	Centrifuge Feed Pumps	11 m <sup>3</sup> /hr. @ 15 MWC	02	1W + 1S
22.1	Centrifuge	11 m <sup>3</sup> /hr.	02	1W + 1S
23.1	Polyelectrolyte Dosing Tank	1500 x 1500 x 1500 SWD.	02	RCC
24.1	Polyelectrolyte Dosing Pumps	230 LPH @ 4.0 kg/cm <sup>2</sup>	02	2W
25.1	Polyelectrolyte Dosing Tank Agitator	1 HP @ 100 RPM	02	2W
26.1	Treated Sewage Effluent Tank	7500 x 4250 x 5000 SWD.	01	RCC
27.1	Service Water Pumps	5 m <sup>3</sup> /hr. @ 25 MWC	02	1W + 1S

MK.NO.	DESCRIPTION	SIZE	QTY	TYPE	OPERATION
1.6	SBR Main Air Line	ISOLATION 300 NB	02	BUTTERFLY	MOTORISED
1.7	Selector Main Air Line	ISOLATION 100 NB	02	BUTTERFLY	MOTORISED
1.8	Selector Air Grid Line	ISOLATION 40 NB	12	BALL	MANUAL
1.9	SBR Air Header	AIR VENT 25 NB	02	SOLENOID	ELECTRICAL
1.10	SBR Inlet	ISOLATION 500x550	02	SLUICE GATE	MOTORISED
2.2	SBR Air Blowers	NON-RETURN 200 NB	03	SWING CHECK	MANUAL
2.3	SBR Air Blowers	DISCHARGE 200 NB	03	BUTTERFLY	MANUAL
4.2	SAS Pump	DISCHARGE 150 NB	02	DUAL PLATE CHECK	MANUAL
4.3	SAS Pump	HEADER 150 NB	01	KNIFE GATE	MANUAL
6.2	Manual Bar Screen (Coarse)	ISOLATION 700x950	01	SLUICE GATE	MANUAL
7.2	Mechanical Bar Screen (Coarse)	ISOLATION 700x950	01	SLUICE GATE	MANUAL
9.2	Raw Sewage Transfer Pump	NON RETURN 250 NB	03	SWING CHECK	-
9.3	Raw Sewage Transfer Pump	DISCHARGE 250 NB	03	KNIFE GATE	MANUAL
9.4	Raw Sewage Transfer Pump	DISCHARGE 350 NB	01	KNIFE GATE	MANUAL
9.5	Raw Sewage Transfer Pump	BYPASS 150 NB	01	KNIFE GATE	MANUAL
10.3	Bio Filter Blower	ISOLATION 300 NB	02	BUTTERFLY	MANUAL
10.4	Bio Filter Blower	DISCHARGE 300 NB	02	SWING CHECK	MANUAL
10.5	Bio Filter Blower	DISCHARGE 300 NB	02	BUTTERFLY	MANUAL
12.2	Manual Bar Screen (Fine)	ISOLATION 700x1000	01	SLUICE GATE	MANUAL
12.3	Manual Bar Screen (Fine)	ISOLATION 700x1000	01	SLUICE GATE	MANUAL
13.2	Mechanical Bar Screen (Fine)	ISOLATION 700x1000	01	SLUICE GATE	MANUAL
13.3	Mechanical Bar Screen (Fine)	ISOLATION 700x1000	01	SLUICE GATE	MANUAL
14.2	Grit Chamber	ISOLATION 500x550	01	SLUICE GATE	MANUAL
14.3	Grit Chamber	BYPASS 500x550	01	SLUICE GATE	MANUAL
18.2	Treated Water Transfer Pump	ISOLATION 200 NB	02	BUTTERFLY	MANUAL
18.3	Treated Water Transfer Pump	SUCTION 150 NB	03	SWING CHECK	-
18.4	Treated Water Transfer Pump	DISCHARGE 150 NB	03	BUTTERFLY	MANUAL
19.2	Sludge Sump Air Blower	NON RETURN 40 NB	03	SWING CHECK	-
19.3	Sludge Sump Air Blower	DISCHARGE 40 NB	02	BUTTERFLY	MANUAL
21.2	Centrifuge Feed Pumps	SUCTION 80 NB	02	KNIFE GATE	MANUAL
21.3	Centrifuge Feed Pumps	DISCHARGE 80 NB	02	KNIFE GATE	MANUAL
23.2	DWPE Tank	DRAIN 80 NB	02	BALL	MANUAL
23.3	DWPE Tank	OUTLET 25 NB	02	BALL	MANUAL
24.2	DWPE Dosing Pumps	SUCTION 25 NB	02	BALL	MANUAL
24.3	DWPE Dosing Pumps	DISCHARGE 25 NB	02	BALL	MANUAL
24.4	Service Water Pumps	INLET 40 NB	02	BALL	MANUAL
27.2	Service Water Pumps	SUCTION 40 NB	02	BALL	MANUAL
27.3	Service Water Pumps	DISCHARGE 40 NB	02	BUTTERFLY	MANUAL
27.4	Service Water Pumps	DISCHARGE 40 NB	02	BALL	MANUAL

LINE LEGEND	INSTRUMENT LIST
--- RAS LINE	MK.NO. DESCRIPTION REMARK
--- SAS LINE	PI 100.1 PRESSURE GAUGES BOURDON TYPE
--- AIR LINE	PI 100.2 PRESSURE GAUGES DIAPHRAGM TYPE
--- INSTRUMENT SIGNAL	DO 100.4 DISSOLVED OXYGEN METER IMMERSION TYPE
--- DRAIN LINE	LT 100.5 LEVEL TRANSMITTER HYDROSTATIC TYPE
--- RCC CHANNEL	VFD 100.6 VARIABLE FREQUENCY DRIVE FOR BLOWERS
--- LEGEND	VFD 100.7 VARIABLE FREQUENCY DRIVE FOR DECATERS
--- (NON-RETURN VALVE)	ST 100.8 SOFT STARTER FOR BLOWER
--- (BUTTERFLY VALVE)	DELS100.9 DECATER LEVEL SENSOR CAPACITIVE TYPE
--- (MOTORISED KNIFE GATE VALVE)	DEPS100.10 DECATER POSITION SENSOR MAGNETIC LIMIT SWITCH
--- (MOTORISED BUTTERFLY VALVE)	LT 100.11 LEVEL TRANSMITTER ULTRASONIC TYPE
--- (KNIFE GATE VALVE)	LT 100.12 LEVEL TRANSMITTER DIFFERENTIAL ULTRASONIC TYPE
--- (BALL VALVE)	LS 100.15 LEVEL SWITCH CAPACITIVE TYPE
--- (VARIABLE FREQUENCY DRIVE)	FT 100.13 FLOW METER ULTRASONIC TYPE
--- (SOFT STARTER)	
--- (MOTOR)	
--- (AIR BLOWER)	
--- (SILENCER)	
--- (FILTER)	

NOTE:-  
 1. ALL UNITS IN RAW SEWAGE PUMPING STATION SHALL BE COVERED WITH FRP SHEET SUPPORTED BY STRUCTURAL STEEL WITH ANTI-CORROSIVE TREATMENT.  
 2. THIS P&ID INDICATES EQUIPMENTS FOR PRESENT + FUTURE

FOR TENDER PURPOSE ONLY

PROJECT: 7.05 MLD SEWAGE TREATMENT PLANT  
 BASED ON SBR AT SECTOR-12 KAMAL VIHAR, RAIPUR  
 TITLE: PIPING & INSTRUMENTATION DIAGRAM

REV.NO	REVISIONS	DRAWN	CHECKED	APPROVED	DATE	REFERENCE DRAWING NO.	REFERENCE DRAWING NAME	SCALE	NTS	PROJECTION

CONT. CODE	DWG. SIZE	DWG. NO.	REV.
-	A2	A2/7.05MLD/101/01	R1

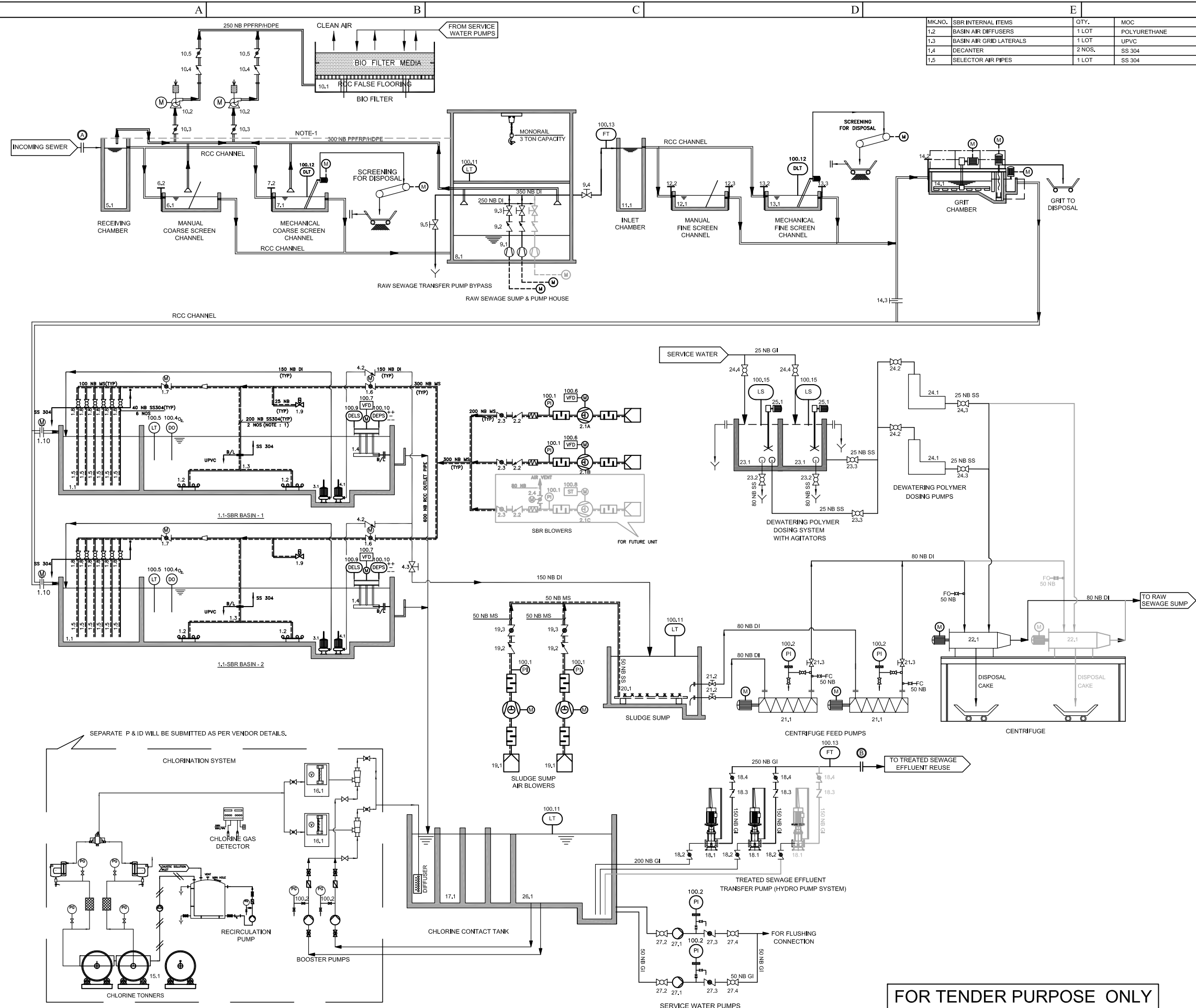

MK.NO.	SBR INTERNAL ITEMS	QTY.	MOC
1.2	250 NB PFRPH/DPE	1 LOT	POLYURETHANE
1.3	BASIN AIR GRID LATERALS	1 LOT	UPVC
1.4	DECANTER	2 NOS.	SS 304
1.5	SELECTOR AIR PIPES	1 LOT	SS 304

MK.NO.	DESCRIPTION	SIZE/CAPACITY	QTY	REMARK
1.1	SBR BASINS - 1/2	30100 x 15000 x 5200 SWD.	02	RCC
2.1	SBR AIR BLOWERS	1800 Nm <sup>3</sup> /hr. @ 0.62 kg/cm <sup>2</sup>	03	2W + 1S
3.1	RETURN ACTIVATED SLUDGE PUMPS	85 m <sup>3</sup> /hr. @ 5 MWC	02	2W
4.1	SURPLUS ACTIVATED SLUDGE PUMPS	50 m <sup>3</sup> /hr. @ 10 MWC	02	2W
5.1	RECEIVING CHAMBER	2000 x 2000 x 1500 SWD.	01	RCC
6.1	MANUAL COARSE SCREEN	3500 x 750 x 650 SWD.	01	RCC
7.1	MECHANICAL COARSE SCREEN	3500 x 750 x 650 SWD.	01	RCC
8.1	RAW SEWAGE SUMP	6500 Ø x 2000 SWD.	01	RCC
9.1	RAW WATER TRANSFER PUMPS	350 m <sup>3</sup> /hr. @ 15 MWC	03	2W+1S
10.1	BIO FILTER	6000 x 2000	01	RCC
10.2	CENTRIFUGAL BLOWERS FOR BIO-FILTER	3500 m <sup>3</sup> /hr. @ 0.2 MWC	02	1W+1S
11.1	INLET CHAMBER	1500 x 2000 x 2000 SWD.	01	RCC
12.1	MANUAL FINE SCREEN	5000 x 700 x 700 SWD.	01	RCC
13.1	MECHANICAL FINE SCREEN	5000 x 700 x 700 SWD.	01	RCC
14.1	GRIT CHAMBER	4500 x 4500 x 900 SWD.	01	RCC
15.1	CHLORIN TONNERS	928 kg	02	1W + 1S
16.1	CHLORINATORS	4 kg/hr	02	1W + 1S
17.1	CHLORINATION TANK CUM TREATED WATER TANK	16500 x 7500 x 2500 SWD.	01	RCC
18.1	TREATED WATER TRANSFER PUMP	166.5 m <sup>3</sup> /hr. @ 45 MWC	03	2W + 1S
19.1	SLUDGE SUMP AIR BLOWERS	70 m <sup>3</sup> /hr. @ 0.35 kg/cm <sup>2</sup>	02	1W + 1S
20.1	SLUDGE SUMP	7000 x 2500 x 3000 SWD.	01	RCC
21.1	CENTRIFUGE FEED PUMPS	11 m <sup>3</sup> /hr. @ 15 MWC	02	1W + 1S
22.1	CENTRIFUGE	11 m <sup>3</sup> /hr.	02	1W + 1S
23.1	POLYELECTROLYTE DOSING TANK	1500 x 1500 x 1500 SWD.	02	RCC
24.1	POLYELECTROLYTE DOSING PUMPS	240 LPH @ 4.0 kg/cm <sup>2</sup>	02	2W
25.1	POLYELECTROLYTE DOSING TANK AGITATOR	1 HP @ 100 RPM	02	2W
26.1	TREATED SEWAGE EFFLUENT TANK	7500 x 4500 x 5000 SWD.	01	RCC
27.1	SERVICE WATER PUMPS	5 m <sup>3</sup> /hr. @ 25 MWC	02	1W + 1S

MK.NO.	DESCRIPTION	SIZE	QTY	TYPE	OPERATION
1.6	SBR MAIN AIR LINE	ISOLATION 300 NB	02	BUTTERFLY	MOTORISED
1.7	SELECTOR MAIN AIR LINE	ISOLATION 100 NB	02	BUTTERFLY	MOTORISED
1.8	SELECTOR AIR GRID LINE	ISOLATION 40 NB	12	BALL	MANUAL
1.9	SBR AIR HEADER	AIR VENT 25 NB	02	SOLENOID	ELECTRICAL
1.10	SBR INLET	ISOLATION 600x600	02	SLUICE GATE	MOTORISED
2.2	SBR AIR BLOWERS	NON-RETURN 200 NB	03	SWING CHECK	MANUAL
2.3	SBR AIR BLOWERS	DISCHARGE 200 NB	03	BUTTERFLY	MANUAL
4.2	SAS PUMP	DISCHARGE 150 NB	02	DUAL PLATE	MANUAL
4.3	SAS PUMP	HEADER 150 NB	01	KNIFE GATE	MANUAL
6.2	MANUAL BAR SCREEN (COARSE)	ISOLATION 750x950	01	SLUICE GATE	MANUAL
7.2	MECHANICAL BAR SCREEN (COARSE)	ISOLATION 750x950	01	SLUICE GATE	MANUAL
9.2	RAW SEWAGE TRANSFER PUMP	NON RETURN 250 NB	03	SWING CHECK	-
9.3	RAW SEWAGE TRANSFER PUMP	DISCHARGE 250 NB	03	KNIFE GATE	MANUAL
9.4	RAW SEWAGE TRANSFER PUMP	DISCHARGE 350 NB	01	KNIFE GATE	MANUAL
9.5	RAW SEWAGE TRANSFER PUMP	DISCHARGE 350 NB	01	KNIFE GATE	MANUAL
10.3	BIO FILTER BLOWER	ISOLATION 300 NB	02	BUTTERFLY	MANUAL
10.4	BIO FILTER BLOWER	DISCHARGE 250 NB	02	SWING CHECK	MANUAL
10.5	BIO FILTER BLOWER	DISCHARGE 250 NB	02	BUTTERFLY	MANUAL
12.2	MANUAL BAR SCREEN (FINE)	ISOLATION 700x1000	01	SLUICE GATE	MANUAL
13.2	MECHANICAL BAR SCREEN (FINE)	ISOLATION 700x1000	01	SLUICE GATE	MANUAL
12.3	MANUAL BAR SCREEN (FINE)	ISOLATION 700x1000	01	SLUICE GATE	MANUAL
13.3	MECHANICAL BAR SCREEN (FINE)	ISOLATION 700x1000	01	SLUICE GATE	MANUAL
14.2	GRIT CHAMBER	ISOLATION 600x600	01	SLUICE GATE	MANUAL
14.3	GRIT CHAMBER	BYPASS 600x600	01	SLUICE GATE	MANUAL
18.2	TREATED WATER TRANSFER PUMP	ISOLATION 200 NB	02	BUTTERFLY	MANUAL
18.3	TREATED WATER TRANSFER PUMP	SUCTION 150 NB	02	SWING CHECK	-
18.4	TREATED WATER TRANSFER PUMP	DISCHARGE 150 NB	03	BUTTERFLY	MANUAL
19.2	SLUDGE SUMP AIR BLOWER	NON RETURN 50 NB	03	SWING CHECK	-
19.3	SLUDGE SUMP AIR BLOWER	DISCHARGE 50 NB	03	BUTTERFLY	MANUAL
21.2	CENTRIFUGE FEED PUMPS	SUCTION 80 NB	02	KNIFE GATE	MANUAL
21.3	CENTRIFUGE FEED PUMPS	DISCHARGE 80 NB	02	KNIFE GATE	MANUAL
23.2	DWPE TANK	DRAIN 80 NB	02	BALL	MANUAL
23.3	DWPE TANK	OUTLET 25 NB	02	BALL	MANUAL
24.2	DWPE DOSING PUMPS	SUCTION 25 NB	02	BALL	MANUAL
24.3	DWPE DOSING PUMPS	DISCHARGE 25 NB	02	BALL	MANUAL
24.4	SERVICE WATER PUMPS	INLET 50 NB	02	BALL	MANUAL
27.2	SERVICE WATER PUMPS	SUCTION 50 NB	02	BALL	MANUAL
27.3	SERVICE WATER PUMPS	DISCHARGE 50 NB	02	BUTTERFLY	MANUAL
27.4	SERVICE WATER PUMPS	DISCHARGE 50 NB	02	BALL	MANUAL

LINE LEGEND	INSTRUMENT LIST
--- GAS LINE	MK.NO. DESCRIPTION REMARK
--- SAS LINE	PI 100.1 PRESSURE GAUGES BOURDON TYPE
--- AIR LINE	PI 100.2 PRESSURE GAUGES DIAPHRAGM TYPE
--- INSTRUMENT SIGNAL	DO 100.4 DISSOLVED OXYGEN METER IMMERSION TYPE
--- DRAIN LINE	LT 100.5 LEVEL TRANSMITTER HYDROSTATIC TYPE
--- RCC CHANNEL	VFD 100.6 VARIABLE FREQUENCY DRIVE FOR BLOWERS
--- LEGEND	VFD 100.7 VARIABLE FREQUENCY DRIVE FOR DECANTERS
--- (NON-RETURN VALVE)	ST 100.8 SOFT STARTER FOR BLOWER
--- (BUTTERFLY VALVE)	DELS100.9 DECANter LEVEL SENSOR CAPACITIVE TYPE
--- (MOTORISED KNIFE GATE VALVE)	DEPS100.10 DECANter POSITION SENSOR MAGNETIC LIMIT SWITCH
--- (MOTORISED BUTTERFLY VALVE)	LT 100.11 LEVEL TRANSMITTER ULTRASONIC TYPE
--- (KNIFE GATE VALVE)	LT 100.12 LEVEL TRANSMITTER DIFFERENTIAL ULTRASONIC TYPE
--- (BALL VALVE)	LS 100.15 LEVEL SWITCH CAPACITIVE TYPE
--- (VARIABLE FREQUENCY DRIVE)	FT 100.13 FLOW METER ULTRASONIC TYPE
--- (SOFT STARTER)	
--- (MOTOR)	
--- (AIR BLOWER)	
--- (SILENCER)	
--- (FILTER)	

NOTE:-  
 1. ALL UNITS IN RAW SEWAGE PUMPING STATION SHALL BE COVERED WITH FRP SHEET SUPPORTED BY STRUCTURAL STEEL WITH ANTI-CORROSIVE TREATMENT.  
 2. THIS P&ID INDICATES EQUIPMENTS FOR PRESENT + FUTURE

FOR TENDER PURPOSE ONLY

REV.NO	REVISIONS	DRAWN	CHECKED	APPROVED	DATE	REFERENCE DRAWING NO.	REFERENCE DRAWING NAME	SCALE	NTS	PROJECTION	CONT. CODE	DWG. SIZE	DWG. NO.	REV.
												A2	A2/7.40MLD/101/01	R1

PROJECT:	7.40 MLD SEWAGE TREATMENT PLANT
BASED ON:	SBR AT SECTOR-1 KAMAL VIHAR, RAIPUR
TITLE:	PIPING & INSTRUMENTATION DIAGRAM
DATE:	24-01-2017
BY:	
SIGN:	
DRAWN:	24-01-2017
DESIGNED:	24-01-2017
CHECKED:	24-01-2017
APPROVED:	24-01-2017

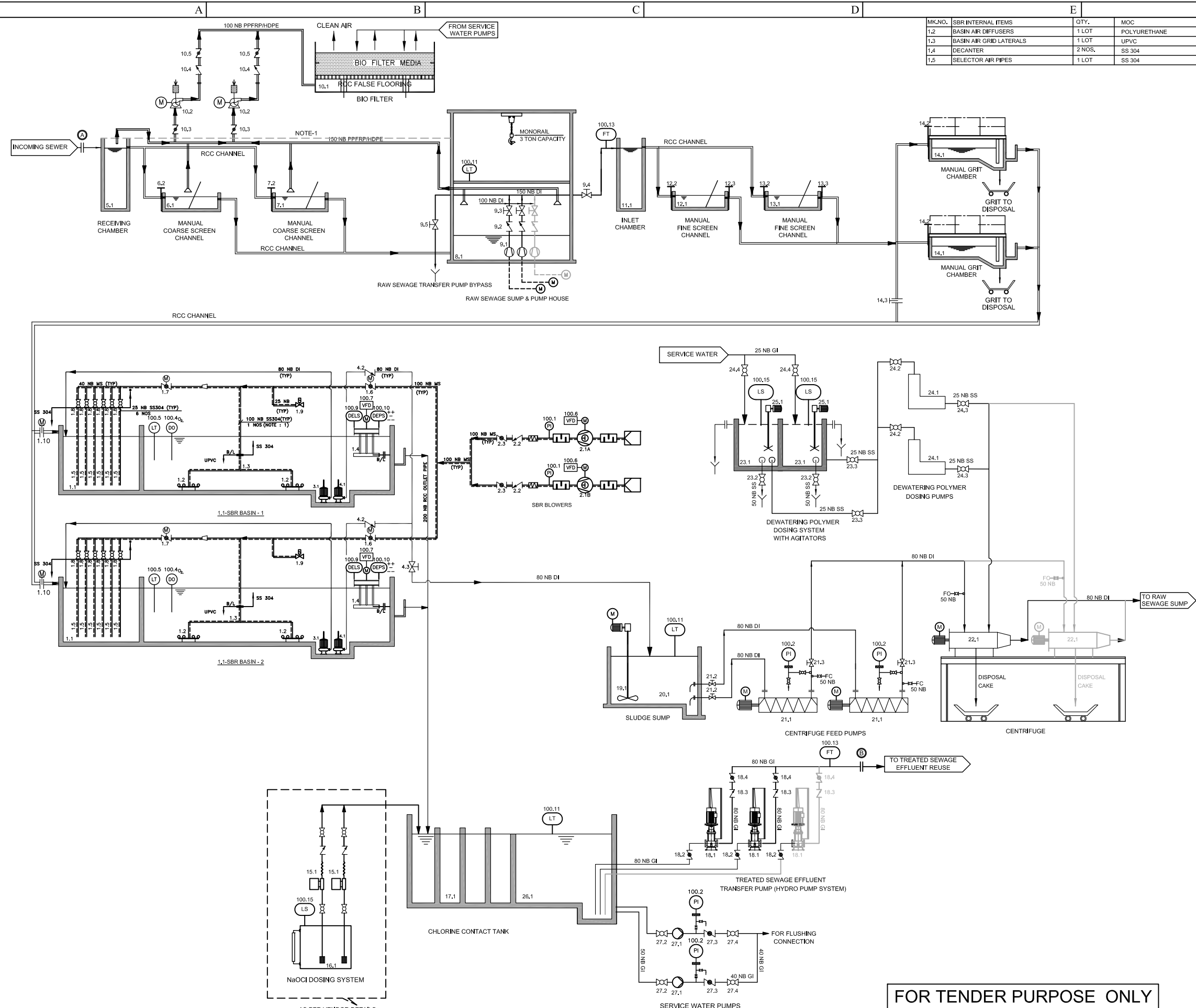

MK.NO.	SBR INTERNAL ITEMS	QTY.	MOC
1.2	BASIN AIR DIFFUSERS	1 LOT	POLYURETHANE
1.3	BASIN AIR GRID LATERALS	1 LOT	UPVC
1.4	DECANTER	2 NOS.	SS 304
1.5	SELECTOR AIR PIPES	1 LOT	SS 304

MK.NO.	DESCRIPTION	SIZE/CAPACITY	QTY	REMARK
1.1	SBR BASINS - 1/2	11600 x 5900 x 5200 SWD.	02	RCC
2.1	SBR AIR BLOWERS	500 Nm <sup>3</sup> /hr. @ 0.62 kg/cm <sup>2</sup>	02	1W + 1S
3.1	RETURN ACTIVATED SLUDGE PUMPS	10 m <sup>3</sup> /hr. @ 5 MWC	02	2W
4.1	SURPLUS ACTIVATED SLUDGE PUMPS	10 m <sup>3</sup> /hr. @ 10 MWC	02	2W
5.1	RECEIVING CHAMBER	800 x 800 x 1500 SWD.	01	RCC
6.1	MANUAL COARSE SCREEN	3000 x 300 x 350 SWD.	01	RCC
7.1	MANUAL COARSE SCREEN	3000 x 300 x 350 SWD.	01	RCC
8.1	RAW SEWAGE SUMP	3000 Ø x 1500 SWD.	01	RCC
9.1	RAW WATER TRANSFER PUMPS	55 m <sup>3</sup> /hr. @ 17 MWC	03	2W+1S
10.1	BIO FILTER	4000 x 1000	01	RCC
10.2	CENTRIFUGAL BLOWERS FOR BIO-FILTER	600 m <sup>3</sup> /hr. @ 0.20 MWC	02	1W+1S
11.1	INLET CHAMBER	800 x 800 x 1500 SWD.	01	RCC
12.1	MANUAL FINE SCREEN	2500 x 300 x 350 SWD.	01	RCC
13.1	MANUAL FINE SCREEN	2500 x 300 x 350 SWD.	01	RCC
14.1	MANUAL GRIT CHAMBER	3500 x 900 x 900 SWD.	02	RCC
15.1	NAOCL DOSING PUMPS	10 LPH	02	1W + 1S
16.1	NAOCL DOSING TANK	100 Ltr.	01	1W
17.1	CHLORINATION TANK CUM TREATED WATER TANK	6500 x 3000 x 2000 SWD.	01	RCC
18.1	TREATED WATER TRANSFER PUMP	20 @ 45 MWC	03	2W + 1S
19.1	SLUDGE SUMP AGITATOR	0.5 HP	01	1W
20.1	SLUDGE SUMP	2000 x 1500 x 2000 SWD.	01	RCC
21.1	CENTRIFUGE FEED PUMPS	2 m <sup>3</sup> /hr. @ 15 MWC	02	1W + 1S
22.1	CENTRIFUGE	2 m <sup>3</sup> /hr.	02	1W + 1S
23.1	POLYELECTROLYTE DOSING TANK	200 Ltr.	02	RCC
24.1	POLYELECTROLYTE DOSING PUMPS	40 LPH @ 4.0 kg/cm <sup>2</sup>	02	2W
25.1	POLYELECTROLYTE DOSING TANK AGITATOR	0.5 HP @ 100 RPM	02	2W
26.1	TREATED SEWAGE EFFLUENT TANK	4000 x 3000 x 1850 SWD.	01	RCC
27.1	SERVICE WATER PUMPS	5 m <sup>3</sup> /hr. @ 25 MWC	02	1W + 1S

MK.NO.	DESCRIPTION	SIZE	QTY	TYPE	OPERATION
1.6	SBR MAIN AIR LINE	ISOLATION 100 NB	02	BUTTERFLY	MOTORIZED
1.7	SELECTOR MAIN AIR LINE	ISOLATION 40 NB	02	BUTTERFLY	MOTORIZED
1.8	SELECTOR AIR GRID LINE	ISOLATION 25 NB	12	BALL	MANUAL
1.9	SBR AIR HEADER	AIR VENT 25 NB	02	SOLENOID	ELECTRICAL
1.10	SBR INLET	ISOLATION 350x350	02	SLUICE GATE	MOTORIZED
2.2	SBR AIR BLOWERS	NON-RETURN 100 NB	03	SWING CHECK	MANUAL
2.3	SBR AIR BLOWERS	DISCHARGE 100 NB	03	BUTTERFLY	MANUAL
4.2	SAS PUMP	DISCHARGE 80 NB	02	DUAL PLATE CHECK	MANUAL
4.3	SAS PUMP	HEADER 80 NB	01	KNIFE GATE	MANUAL
6.2	MANUAL BAR SCREEN (COARSE)	ISOLATION 300x650	01	SLUICE GATE	MANUAL
7.2	MANUAL BAR SCREEN (COARSE)	ISOLATION 300x650	01	SLUICE GATE	MANUAL
9.2	RAW SEWAGE TRANSFER PUMP	NON RETURN 100 NB	03	SWING CHECK	-
9.3	RAW SEWAGE TRANSFER PUMP	DISCHARGE 100 NB	03	KNIFE GATE	MANUAL
9.4	RAW SEWAGE TRANSFER PUMP	DISCHARGE 150 NB	01	KNIFE GATE	MANUAL
9.5	RAW SEWAGE TRANSFER PUMP	BYPASS 100 NB	01	KNIFE GATE	MANUAL
10.3	BIO FILTER BLOWER	ISOLATION 150 NB	02	BUTTERFLY	MANUAL
10.4	BIO FILTER BLOWER	DISCHARGE 100 NB	02	SWING CHECK	MANUAL
10.5	BIO FILTER BLOWER	DISCHARGE 100 NB	02	BUTTERFLY	MANUAL
12.2	MANUAL BAR SCREEN (FINE)	ISOLATION 300x650	01	SLUICE GATE	MANUAL
12.3	MANUAL BAR SCREEN (FINE)	ISOLATION 300x650	01	SLUICE GATE	MANUAL
13.2	MANUAL BAR SCREEN (FINE)	ISOLATION 300x650	01	SLUICE GATE	MANUAL
13.3	MANUAL BAR SCREEN (FINE)	ISOLATION 300x650	01	SLUICE GATE	MANUAL
14.2	GRIT CHAMBER	ISOLATION 350x350	02	SLUICE GATE	MANUAL
14.3	GRIT CHAMBER	BYPASS 350x350	01	SLUICE GATE	MANUAL
18.2	TREATED WATER TRANSFER PUMP	ISOLATION 80 NB	03	BUTTERFLY	MANUAL
18.3	TREATED WATER TRANSFER PUMP	SUCTION 80 NB	03	SWING CHECK	-
18.4	TREATED WATER TRANSFER PUMP	DISCHARGE 80 NB	03	BUTTERFLY	MANUAL
21.2	CENTRIFUGE FEED PUMPS	SUCTION 80 NB	02	KNIFE GATE	MANUAL
21.3	CENTRIFUGE FEED PUMPS	DISCHARGE 80 NB	02	KNIFE GATE	MANUAL
23.2	DWPE TANK	DRAIN 50 NB	02	BALL	MANUAL
23.3	DWPE TANK	OUTLET 25 NB	02	BALL	MANUAL
24.2	DWPE DOSING PUMPS	SUCTION 25 NB	02	BALL	MANUAL
24.3	DWPE DOSING PUMPS	DISCHARGE 25 NB	02	BALL	MANUAL
24.4	SERVICE WATER PUMPS	INLET 25 NB	02	BALL	MANUAL
27.2	SERVICE WATER PUMPS	SUCTION 50 NB	02	BALL	MANUAL
27.3	SERVICE WATER PUMPS	DISCHARGE 40 NB	02	BUTTERFLY	MANUAL
27.4	SERVICE WATER PUMPS	DISCHARGE 40 NB	02	BALL	MANUAL

LINE LEGEND	INSTRUMENT LIST
--- RAS LINE	MK.NO. DESCRIPTION REMARK
--- SAS LINE	PI 100.1 PRESSURE GAUGES BOURDON TYPE
--- AIR LINE	PI 100.2 PRESSURE GAUGES DIAPHRAGM TYPE
--- INSTRUMENT SIGNAL	DO 100.4 DISSOLVED OXYGEN METER IMMERSION TYPE
--- DRAIN LINE	LT 100.5 LEVEL TRANSMITTER HYDROSTATIC TYPE
--- RCC CHANNEL	VFD 100.6 VARIABLE FREQUENCY DRIVE FOR BLOWERS
--- LEGEND	100.7 VARIABLE FREQUENCY DRIVE FOR DECANTERS
--- NON-RETURN VALVE	ST 100.8 SOFT STARTER FOR BLOWER
--- BUTTERFLY VALVE	DELS100.9 DECANTER LEVEL SENSOR CAPACITIVE TYPE
--- MOTORISED KNIFE GATE VALVE	DEPS100.10 DECANTER POSITION SENSOR MAGNETIC LIMIT SWITCH
--- MOTORISED BUTTERFLY VALVE	LT 100.11 LEVEL TRANSMITTER ULTRASONIC TYPE
--- CHANNEL MOUNTED MOTORISED GATE	DLT 100.12 LEVEL TRANSMITTER DIFFERENTIAL ULTRASONIC TYPE
--- KNIFE GATE VALVE	LS 100.15 LEVEL SWITCH CAPACITANCE TYPE
--- BALL VALVE	FT 100.13 FLOW METER ULTRASONIC TYPE
--- VARIABLE FREQUENCY DRIVE	
--- SOFT STARTER	
--- MOTOR	
--- AIR BLOWER	
--- SILENCER	
--- FILTER	

NOTE:-  
 1. ALL UNITS IN RAW SEWAGE PUMPING STATION SHALL BE COVERED WITH FRP SHEET SUPPORTED BY STRUCTURAL STEEL WITH ANTI-CORROSIVE TREATMENT.  
 2. THIS P&ID INDICATES EQUIPMENTS FOR PRESENT + FUTURE

**FOR TENDER PURPOSE ONLY**

PROJECT: 872 KLD SEWAGE TREATMENT PLANT  
 BASED ON SBR AT SECTOR-11b KAMAL VIHAR, RAIPUR  
 TITLE: PIPING & INSTRUMENTATION DIAGRAM

REV.NO	REVISIONS	DRAWN	CHECKED	APPROVED	DATE	REFERENCE DRAWING NO.	REFERENCE DRAWING NAME	SCALE	NTS	PROJECTION

CONT. CODE	DWG. SIZE	DWG. NO.	REV.
-	A2	A2/872KLD/101/01	R1

ESP-001-  
2A Rev.00



**PROJECT ENGINEERING & SYSTEMS DIVISION**

Std. / Doc. Number

Annexure-2

Rev. No. 00

**COPYRIGHT AND CONFIDENTIAL**

The information on this document is the property of **BHARAT HEAVY ELECTRICALS LIMITED**,  
It must not be used directly or indirectly in any way detrimental to the interest of the company.

# **Annexure-2**

## **DATA SHEET OF BLOWER-MOTOR ASSEMBLY**

**Revisions:**  
Refer to record of revisions

Sl. No.	Description	Rev.	Date	By

**CUSTOMER:RAIPUR DEVELOPMENT AUTHORITY**  
**PROJECT: 6 Nos. of STP PROJECT OF VARIOUS CAPACITY,RDA-RAIPUR**

<b>DATA SHEET FOR CENTRIFUGAL AIR BLOWER</b>			
SI. No.	Description	BHEL Requirement	DETAILS
<b>GENERAL DATA</b>			
1	Service	To Transfer Foul Smell Air from SBR Tank to Bio Filter	
2	Number of Air Blowers	2 Nos.[1 W+1S] for Each 6 STPs Total : 12Nos.	
3	Location	Outdoor	
4	Duty	Continuous	
5	Drives	Motor [V Belt Driven].	
6	Pumping fluid	Ambient Air	
7	Fluid temp Deg C	Ambient [50 Deg.C]	
<b>AIR BLOWER PERFORMANCE &amp; OTHER DETAILS</b>			
8	Air Blower Type	Centrifugal Type Air Blower	
9	Design Standard of Blower	To be mentioned by Bidder	
10	Rated Blower Parameters	<b>For 7.40 MLD STP AT SECTOR - 1:</b> Flow:3500 m3/hr,Head:0.2 mwc	
		<b>For 4.33 MLD STP AT SECTOR - 6:</b> Flow:4900 m3/hr,Head:0.2 mwc	
		<b>For 7.05 MLD STP AT SECTOR - 12:</b> Flow:4500 m3/hr,Head:0.2 mwc	
		<b>For 1.79 MLD STP AT SECTOR - 11a:</b> Flow:1200 m3/hr,Head:0.2 mwc	
		<b>For 0.872 MLD STP AT SECTOR - 11 b:</b> Flow:600 m3/hr,Head:0.2 mwc	
		<b>For 3.98 MLD STP AT INDRAPRASTHA:</b> Flow:2000 m3/hr,Head:0.2 mwc	
11	Differential Head(In mlc)	As mentioned in Sl. No. 1 above	
12	Air Blower Model No.	To be mentioned by Bidder	
13	No. of Stages of Air Blower	To be mentioned by Bidder	
14	Parallel operation	Not Applicable	
15	Rated Speed of Air Blower (rpm)	Less than 1500rpm	
16	Rated speed of Motor (rpm)	Less than 1500rpm	
17	Air Blower Efficiency in %	To be mentioned by Bidder	
18	Available Pressure at inline of Suction Silence	Atmospheric Pressure	
<b>AIR BLOWER CONSTRUCTION FEATURES</b>			
19	Material of Construction: Casing: Carbon Steel as per IS 2062 Gr. A, Impeller: Carbon Steel as per IS 2062 Gr. A Stand: Carbon Steel as per IS 2062 Gr. A Shaft : SS410, Gaskets: Neoprene Bearing: SKF/Equivalent Other Parts shall be as per Manufacturer Standard. * In case bidder can't meet above mentioned material, Bidder can offer Equivalent /Superior material suitable to the requirement.	To be Confirmed by Bidder	
20	Sealing arrangement	Sealing as per Manufacturer's Standard.	
21	Type of bearings for Air Blower	To be mentioned by Bidder	
22	Bearings lubrication	To be mentioned by Bidder	
23	V- Belt used between Blower and Motor/Direct Drive	To be mentioned by Bidder	
<b>PERFORMANCE TEST STANDARD FOR AIR BLOWER</b>			
24	Performance test standard	To be mentioned by Bidder	
25	Maximum Allowed Working Pressure (MAWP) in Kg/cm <sup>2</sup> g	To be mentioned by Bidder	
26	Hydraulic test pressure of casing Kg/cm <sup>2</sup> (g)	Hydraulic test pressure of casing shall be 1.5 times the MAWP. Test duration shall be minimum 30 min.	
27	Noise level for Air Blower	85 dBA at 2.0 m in any direction	
28	Vibration for Air Blower	As per BS 4675: Part-I to III, Subclass B or Better. At Motor Bearing, Pump Bearing Housing and Base Plate, Max. Vibration shall be limited to 2.8 mm/Sec. RMS within +/- 10% rated head, While the limit is 4.5 mm/s RMS for balanced portion from shutoff to Maximum flow.	
29	Air Blower Instruments	As per Manufacturer recommendation duly taking care of requirements mentioned in Cl. No. 6 of BHEL tender Specification	

**CUSTOMER:RAIPUR DEVELOPMENT AUTHORITY**  
**PROJECT: 6 Nos. of STP PROJECT OF VARIOUS CAPACITY,RDA-RAIPUR**

Sl. No.	Description	BHEL Requirement	DETAILS
<b>MOTOR DETAILS</b>			
30	Drive	Motor	
31	BKW at the rated point		
32	BKW at End of Curve		
33	Selected drive rating in kW: The power rating of the pump motor shall be the higher of following: (a) 10% above the maximum power requirement by the blower (b) End of the curve requirement.	Bidder to mention motor kW rating for the motor duly taking care of the requirements.	
34	Design Standard of Motor	IS 325/IEC60034	
35	Energy Efficiency Class	IE3 as per IS 12615	
36	Manufacturer	As per Approved Sub Vendor List	
37	Ambient Temperature	50 Deg C All motors shall be designed to operate in humid atmosphere with a maximum ambient temperature of 50 Deg C.	
38	Area classification for motor	Safe Area	
39	Rated Voltage & Frequency	415 V & 50 Hz	
40	Permissible variations in Voltage/Frequency/Combined	(+/-)/10%/(+/-)/5%/(+/-)/10%	
41	No of poles / synchronous speed	Based on Air Blower Speed	
42	Method of Starting	Motor shall be capable of starting with DOL	
43	Method of cooling	To be Confirmed by Bidder	
44	Class of Insulation & Temp. rise	Class F with Temperature rise ltd. to class B	
45	Degree of protection	IP 55	
46	TB Short time-Current & Short time-Time	40 kA , 0.25 Sec	
47	Cable, Cable glands & Lugs	Cable details shall be furnished during DDE. Accordingly suitable double compression Nickel plated brass cable glands with back nut and PVC shroud and Tinned copper lugs to be provided by the bidder.	
48	No. of Starts	4 Cold Starts & 3 Hot Starts	

ESP-001-2A Rev.00		PROJECT ENGINEERING & SYSTEMS DIVISION	Std. / Doc. Number	
			Annexure-3 to Doc. No. PY51289	
			Rev. No.	00

<p style="text-align: center;"><b>COPYRIGHT AND CONFIDENTIAL</b></p> <p>The information on this document is the property of <b>BHARAT HEAVY ELECTRICALS LIMITED</b>, It must not be used directly or indirectly in any way detrimental to the interest of the company.</p>	<h1>Annexure-3</h1> <h2>PRICE BID FORMAT</h2>
--	---

<b>Revisions:</b> Refer to record of revisions	<b>Prepared by :</b>	<b>Checked by :</b>	<b>Approved by :</b>	<b>Date :</b>
	Rajeev Jain	GIRISH	Siva Prasad Babu	11.12.17

## Annexure-3-I

BHARAT HEAVY ELECTRICALS LIMITED  
PROJECT ENGINEERING & SYSTEMS DIVISION  
RAMACHANDRAPURAM: HYDERABAD - 502 032

SL NO	ITEM DESCRIPTION	QTY	UNIT	Weightage w.r.t Overall Price (In %)	Bidder confirmation (Quoted/ Not Quoted)	HSN/SAC Code	GST (%)
<p><b>PRICE FORMAT (R00) FOR CENTRIFUGAL AIR BLOWER WITH ELECTRIC MOTOR DRIVE FOR CUSTOMER : RAIPUR DEVELOPMENT AUTHORITY PROJECT : RDA, STPs Project</b></p>							
<p>Bidder's Name :- &lt;Bidder to indicate&gt; Bidder's Offer No. &amp; Dt. :- &lt;Bidder to indicate&gt; Bidder's Ref No. &amp; Dt. :- &lt;Bidder to indicate&gt; BHEL Enq. No. &amp; date :- &lt;Bidder to indicate&gt;</p>							
<b>1</b>	<b>MAIN OFFER</b>						
<b>A</b>	<b>Centrifugal Air Blower with Drive Assembly:[Flow:3500 m3/hr,Head:0.2 mwc] for 7.40 MLD AT SECTOR - 1 STP Project [Material Code:PY9751444012]</b>						
	Centrifugal Air Blower along with all required Accessories in order to make system complete,Commissioning Spares,Special tools & Tackles, O&M Spares, testing requirements etc. as per specification. <b>Following O&amp;M Spares as mentioned in Cl. No. 6.14 of BHEL tender Specification shall be included as main supply only and price of the same shall also be included in this part.</b> a) Seal -1 Set/Blower b) O-Rings & Gaskets-1 Set/Blower c) Bearing for Blower- 1Set/Blower d) Bearing for Motor- 1Set/Blower 1 Set stands for replacement of total requirement for 1 Blower.	2	Nos.	17.29			
<b>B</b>	<b>Centrifugal Air Blower with Drive Assembly:[Flow:4900 m3/hr,Head:0.2 mwc] for 4.33 MLD AT SECTOR - 6 STP Project[Material Code: PY9751444055]</b>						
	Centrifugal Air Blower along with all required Accessories in order to make system complete,Commissioning Spares,Special tools & Tackles, O&M Spares, testing requirements etc. as per specification. <b>Following O&amp;M Spares as mentioned in Cl. No. 6.14 of BHEL tender Specification shall be included as main supply only and price of the same shall also be included in this part.</b> a) Seal -1 Set/Blower b) O-Rings & Gaskets-1 Set/Blower c) Bearing for Blower- 1Set/Blower d) Bearing for Motor- 1Set/Blower 1 Set stands for replacement of total requirement for 1 Blower.	2	Nos.	17.04			
<b>C</b>	<b>Centrifugal Air Blower with Drive Assembly:[Flow:4500 m3/hr,Head:0.2 mwc] for 7.05 MLD AT SECTOR - 12 STP Project [Material Code:PY9751444098]</b>						
	Centrifugal Air Blower along with all required Accessories in order to make system complete,Commissioning Spares,Special tools & Tackles, O&M Spares, testing requirements etc. as per specification. <b>Following O&amp;M Spares as mentioned in Cl. No. 6.14 of BHEL tender Specification shall be included as main supply only and price of the same shall also be included in this part.</b> a) Seal -1 Set/Blower b) O-Rings & Gaskets-1 Set/Blower c) Bearing for Blower- 1Set/Blower d) Bearing for Motor- 1Set/Blower 1 Set stands for replacement of total requirement for 1 Blower.	2	Nos.	16.02			
<b>D</b>	<b>Centrifugal Air Blower with Drive Assembly:[Flow:1200 m3/hr,Head:0.2 mwc] for 1.79 MLD STP AT SECTOR – 11a STP Project [Material Code:PY9751444136]</b>						
	Centrifugal Air Blower along with all required Accessories in order to make system complete,Commissioning Spares,Special tools & Tackles, O&M Spares, testing requirements etc. as per specification. <b>Following O&amp;M Spares as mentioned in Cl. No. 6.14 of BHEL tender Specification shall be included as main supply only and price of the same shall also be included in this part.</b> a) Seal -1 Set/Blower b) O-Rings & Gaskets-1 Set/Blower c) Bearing for Blower- 1Set/Blower d) Bearing for Motor- 1Set/Blower 1 Set stands for replacement of total requirement for 1 Blower.	2	Nos.	16.48			
<b>E</b>	<b>Centrifugal Air Blower with Drive Assembly:[Flow:600 m3/hr,Head:0.2 mwc] for 0.872 MLD STP AT SECTOR – 11 b STP Project [Material Code:PY9751444268]</b>						
	Centrifugal Air Blower along with all required Accessories in order to make system complete,Commissioning Spares,Special tools & Tackles, O&M Spares, testing requirements etc. as per specification. <b>Following O&amp;M Spares as mentioned in Cl. No. 6.14 of BHEL tender Specification shall be included as main supply only and price of the same shall also be included in this part.</b> a) Seal -1 Set/Blower b) O-Rings & Gaskets-1 Set/Blower c) Bearing for Blower- 1Set/Blower d) Bearing for Motor- 1Set/Blower 1 Set stands for replacement of total requirement for 1 Blower.	2	Nos.	16.47			

F	Centrifugal Air Blower with Drive Assembly-[Flow:2000 m3/hr,Head:0.2 mwc] for 3.98 MLD STP AT INDRAPRASTHA STP Project [Material Code:PY9751444217]					
	Centrifugal Air Blower along with all required Accessories in order to make system complete,Commissioning Spares,Special tools & Tackles, O&M Spares, testing requirements etc. as per specification <b>Following O&amp;M Spares as mentioned in Cl. No. 6.14 of BHEL tender Specification shall be included as main supply only and price of the same shall also be included in this part.</b> a) Seal -1 Set/Blower b) O-Rings & Gaskets-1 Set/Blower c) Bearing for Blower- 1Set/Blower d) Bearing for Motor- 1Set/Blower 1 Set stands for replacement of total requirement for 1 Blower.	2	Nos.	16.27		
G	<b>Supervision charges for Erection &amp; Commissioning of Complete System at site [Material code:PY9851444251]</b>					
	Supervision charges for erection & commissioning shall include the following: 1. Per diem charge of for supervision of erection & commissioning of Air Blower and its associated accessories. 2. Charges for 1 visit Note: The above shall also include all other expenses like boarding, lodging, local travel, insurance, travel expenses (inclusive of all other charges like visa fee (if applicable), insurance etc) from / to vendor works to site for Engineer. [Refer Note 11]	2 Day and 1 Visit		0.43		
<b>Grand total price for Sl. No. A to G (Inclusive of Packing &amp; Forwarding, Freight )</b>				100		
<b>Packing &amp; Forwarding, Frieght, Insurance and GST :</b>						
<b>(I) For Supply:</b>						
(i) Packing & Forwarding :	In bidder scope			Included in basic price		
(ii) Frieght:	In bidder scope			Included in basic price		
(iii) Insurance:	In BHEL scope			-		
(iv) GST	Extra at actuals			Extra at actuals		
(v) Any other:	shall be included in basic price			Included in basic price		
<b>(II) For supervision of E&amp;C:</b>						
(i) GST:	Extra at actuals			Extra at actuals		
(ii) Any other:	Included in basic price			Included in basic price		
<b>Notes:</b>						
1) Bidders should quote the Total Bid Value in both in figures & words in the specified place.						
2) Bidders should mention the applicable HSN/SAC code along with GST% against respective line items.						
3) Bidders shall NOT fill/edit/modify anything in the Price Bid Format.						
4) The rates of line items mentioned in the Price Format shall be derived by BHEL by multiplying the Total Bid Value quoted by the Bidder with the Weightage Factor assigned against respective line items. The rate of each item shall be rounded off to the next 1 (one) Indian paise.						
5) The Total Bid Value quoted by the Bidder shall represent the total landed cost for this enquiry and shall include Packing & Forwarding Charges, Freight Charges. GST shall be paid extra by BHEL at applicable rates.						
6) Evaluation shall be done on the basis of total bid value (Grand Total Price as above) i.e. the total landed cost to BHEL for this enquiry.						
7) The bidders will also provide UN-PRICED PRICE FORMAT strictly in the BHEL price format given above, in the techno commercial part of their offers. BID WILL BE REJECTED IF ANY OTHER PRICE FORMAT IS USED. Both priced and un-priced price formats to be provided by the bidders shall be signed and stamped copies.						
8) Bidder to quote strictly as per BHEL's NIT requirements.						
9) Bidder to note that this is a LUMP SUM Turn-Key Order. However (a) Changes to the tender specification during execution of the project for successful operation of the system need to be carried out by bidder and commercial implications if any will be settled suitably. (b) Unit rates quoted by bidder shall be applicable for any changes in BOQ during detailed engineering stage.						
10) Main offer (Annexure-3-I) consists of those items which will be part of main order after successful bidder is identified. Optional Items (Annexure-3-II) consists of those items which need to be quoted by bidder but may or may not be ordered by BHEL. Bidders are instructed to provide the pricing details listed under Main offer and Optional items as per the prescribed format.						
11) Prices quoted by bidders for items under main offer : Sl. No. I(A+B+C+D+E+F+G) will be considered for evaluation of lowest bidder. i) With respect to Supervision charges, prices quoted by bidder shall be considered for L1 bidder evaluation. ii) Bidder to provide total price against sl. No. K, that include per diem supervision of 1 service person (50% of sl. No. G price) for 2 days chnargns including boarding and lodging and local convenience etc+ To and fro Travel expenses (50% of Sl. No. G price) iii) Referring to Sl. No. G - Supervision charges for Air Blower, For the purpose of Quotation, total no of 2 man days will be covered in 1 visits have been considered and payment against Sl.No. G above shall be made as per the actual number of visits and man days required for the supervision of the complete E&C activities as per these diem rates. Purchase Order shall be placed by BHEL- PE&SD Hyderabad. For Supervision of E&C,PO shall be placed by BHEL-PE&SD as required.  However, BHEL reserves the right (a) To include any of the optional items in scope of supply (as per customer contract requirements) and accordingly consider the same in evaluation. Any such scope increase and change in evaluation will be intimated to vendor during technical evaluation(before price bid opening). (b) To place PO for any of the Optional items with in the contract period. Hence bidders need to MANDATORILY QUOTE reasonable prices for all OPTIONAL ITEMS considering such requirement and keep the validity of the prices till the end of contract period.						
12) For all items including Optional items, prices to be furnished in this prescribed price bid format only for each individual item. The price to be quoted against Sl no A to C shall be Weightage w.r.t Overall Price as mentioned above. No combined prices, common prices or any other format will be accepted and such bids may be liable for rejection. 12 b) Bidder must NOT change the indicated item description, quantity & units in the price bid format. Bidder should only fill the unit rates & total price. 12 c) Bidder to quote for ALL the items as per price bid format. Incomplete/partial offer may be liable for rejection.						
13 a.) Commissioning spares are those spares which are required at the time of commissioning and shall be recommended (as per bidder's experience) and quoted by bidder. However commissioning spares indicated in the price bid format shall be quoted as minimum. 13.b) Commissioning spare consumed over and above the recommended commissioning spares, during commissioning shall be supplied free of cost by the equipment vendor.						
14) With respect to Mandatory Spares, A) If any of above items indicated by the specified name are not applicable, bidder to offer alternative item serving the same function as per equipment's design and indicate below the item being replaced. B) If bidder is not able to meet the above note, then bidder may mention "Not Applicable". However, if found applicable during detailed engg. stage or alternative item as per equipment design can serve the same function, bidder to supply the specified quantity with out any delivery and commercial implications to BHEL.						
15) Reference document: PY51444, R00 & annexures.						
16) Unpriced price bid format indicating as "Quoted" against each applicable item shall be submitted duly signed & stamped along with technical offer by bidder as a token of concurrence that prices are submitted in this format only. The offer shall be liable for rejection in case if un-priced price bid format is not submitted or any modification is carried out in price bid format.						
17) In case the systems are being supplied from outside India, reputed Third Party Inspection has to be considered and the charges should be included in the Main offer. The list of applicable third party shall be furnished during details Engg. For those bidders who are supplying from India, such third party inspection charges need not be considered and same will be arranged by BHEL/BHEL nominated inspection agency.						

**Annexure-3-II**



**BHARAT HEAVY ELECTRICALS LIMITED  
PROJECT ENGINEERING & SYSTEMS DIVISION  
RAMACHANDRAPURAM: HYDERABAD - 502 032**

**PRICE FORMAT (R00) FOR CENTRIFUGAL AIR BLOWER WITH ELECTRIC MOTOR DRIVE FOR  
CUSTOMER : RAIPUR DEVELOPMENT AUTHORITY  
PROJECT : RDA, STPs Poject**

SL NO	ITEM DESCRIPTION	QTY	UNIT	Bidder confirmation (Quoted/ Not Quoted)	HSN/SAC Code	GST (%)
	Bidder's Name : <Bidder to indicate> Bidder's Offer No. & Dt. : <Bidder to indicate> Bidder's Ref No. & Dt. : <Bidder to indicate> BHEL Enq. No. & date : <Bidder to indicate>					
<b>I</b>	<b>Optional Items</b>	--	--			
<b>A</b>	<b>10 Years Recommended Spares</b>					
	Recommended spares list for 10 years normal operation along with unit price breakup for Air Blower (List with price break up to be enclosed) (1 set stands for quantity required for the replacement of Any Items of Each Air Blower		As per List Provided by Bidder			



**ANNEXURE-4 OF BHEL TENDER SPECIFICATION (Doc. No. PY 51444)**

**CHECKLIST FOR OFFER FOR CENTRIFUGAL AIR BLOWER**

Description	Enclosed (Yes/ No)
<p>Bidder to confirm that the following documents are submitted along with their offer to enable BHEL to evaluate the offer.</p> <p>a) <u>Duly filled in Air Blower-Motor datasheet [Annexure: 2]</u></p> <p>b) <u>Preliminary GADs having Complete Details such as Foundation Details, Load Details, Dimensions etc.</u></p> <p>c) <u>Performance Curves of Air Blower</u></p> <p>d) <u>Un-priced copy of attached BHEL price bid formats [Annexure: 3] indicating quoted/not quoted against each row &amp; column.</u></p> <p>e) <u>Pre-Qualification criteria / PTR / Reference Lists [Annexure: 6]</u></p> <p>f) <u>Checklist [Annexure: 4]</u></p> <p>g) <u>Deviation list [Annexure: 10] duly mentioning “No Deviation”.</u></p> <p><b>Datasheets in formats as mentioned in Annexure-2 shall be provided. Data sheet submitted by bidder other than format as per Annexure-2 shall not be reviewed and kept for information only.</b></p>	
Bidder to confirm to the scope of supply as per BHEL specs Doc. No. PY 51444.	
Bidder to ensure that Centrifugal Air Blower is quoted as per BHEL tender Specification.	
Bidder to confirm that all the Suitable reducers/expanders & counter flanges along with gaskets & stud nuts at all the terminal point, shall be in their scope inline with P&ID (Annexure-1 of Doc. No. PY51444).	
Bidder to confirm that the Motor Efficiency class considered is IE3 as per IS 12615 as per BHEL tender Specification.	
Bidder to furnish a list of commissioning spares (Refer Cl. No. 6.11 of Doc. No PY51444).	
Bidder to furnish a list of special tools & tackles (Refer Cl. No. 6.13 of Doc. No. PY51444).	
Bidder to confirm that the O&M Spares as indicated in Sl. No. 6.14 of Doc. No. PY51444 is considered in Bidders scope of supply.	
Bidder to furnish reference list for the offered Blower in line with Cl. No. 7.0 of Doc. No. PY51444.	
Bidder to furnish a list of 10 Years Recommended Spares along with offer as an optional Item.	

Bidder to furnish the filled in unpriced price bid format along with their offer as per Annexure-3 of Doc. No. PY51444.	
Bidder to quote individual price for each item mentioned in the seal priced bid as per price bid format (Annexure-03 of BHEL specs Doc. No. of Doc. No. PY51444). Bidder to confirm the same.	
Make of all the items shall be as per Annexure-8 (Sub-Vendor List). Bidder to confirm.	
Bidder to raise Pre bid queries, if any, must be raised as per Attached format (Annexure-07) before submission of technical and commercial bid. Any deviation/ queries raised during technical bid submission shall not be entertained.	
Bidder to confirm compliance with Annexure-9, Master Document List enclosed with Tender Specification, w.r.t list of documents, schedule of submission.	
Any specific deviations, which are impractical, shall be raised in form of pre-bid queries as per Annexure-11 before submission of Techno Commercial offer. Any deviation/ queries raised during technical bid submission shall not be entertained. Bidder to Confirm.	
Bidder to quote Price Bid as per Annexure-3, Price Bid Format only, clearly indicating all the applicable items and highlighting not applicable items clearly. Un priced copy of the same is enclosed with bidder's technical offer. Bidder to check and confirm.	
Bidder to confirm that the prices of respective items is matching with the weightage% of total price mentioned against each item.	

SIGNATURE:  
NAME:  
DESIGNATION:  
COMPANY:  
DATE:

ESP-001-  
2A Rev.00



**PROJECT ENGINEERING & SYSTEMS DIVISION**

Std. / Doc. Number

Rev. No. 00

**COPYRIGHT AND CONFIDENTIAL**

The information on this document is the property of **BHARAT HEAVY ELECTRICALS LIMITED**,  
It must not be used directly or indirectly in any way detrimental to the interest of the company.

# Annexure-5

## PACKING & FORWARDING SPECIFICATION

**Revisions:**

Refer to record of revisions

No.	Description	By	Date

	<h1>CORPORATE STANDARD</h1>	AA0490010
		Rev. No. 01
		PAGE 1 of 26

## DOMESTIC PACKING

### COMMON GUIDELINES

#### 1 GENERAL:

This standard lays down packing instructions for domestic packing of Components/Assemblies/Equipment to be despatched against Customer's contracts, for which there are no special instructions issued by the Engineering Departments.

The Components/Assemblies need to be packed suitably to avoid physical damage & corrosion during transit & storage. For specific applications the concerned engineering department shall issue a product standard. Reference of this product standard, must appear in the Shipping list/Packing List.

#### 2 TYPES OF PACKING:

The following 5 types of packings have been standardized for packing of General Components/Assemblies.

- 1) 'OP' - Open Type.
- 2) 'PP' - Partially Packed.
- 3) 'CP' – Crate/Box Packing - Components/Equipment requiring physical protection.
- 4) 'CQ' - Case Packing - Small & Medium Components/ Assemblies/ Equipment which require corrosion & physical protection.
- 5) 'CR' - Case Packing - Electrical Components/Assemblies, which require special packing viz. Water Proof, Shock Proof etc...

#### 3 DESCRIPTION OF TYPES OF PACKING:

The various types of packing, as standardized above, are described below.

##### 3.1 'OP' - Open Type

In case, of components which are not affected by water & dust and do not require special protection, are generally not machined, shall be sent as open packages. However, these components may be sent in crates, wherever necessary.

##### 3.2 'PP' - Partially Packed

Components which need special protection at selected portions only shall be despatched partially packed. Machined surfaces should not be allowed to come directly in contact with the wood. Such surfaces should be protected with 70GSM(Colourless) Multi Layered Cross Laminated Polyethylene Film to Specification No.AA51420. All sharp corners and edges shall be protected by rubber mats to prevent damage to the polyethylene film

##### 3.3 'CP' - Crate Packing

Assemblies/Components which need only physical protection from the point of view of handling shall be despatched duly packed in crates.

##### 3.4 'CQ' - Case Packing - Machined Components/Assemblies/Equipment

Small and medium sized components/assemblies/equipment due to size/weight and to avoid handling and pilferage problems shall be packed in Case/Containers. Wherever required adequate quantity of

Revisions:			<b>APPROVED:</b> PROCEDURAL GUIDELINES COMMITTEE – PGC (Packing)		
Rev. No. 01	Amd. No.	Reaffirmed	Prepared HPBP, Trichy	Issued Corp. R&D	Dt. of 1 <sup>st</sup> Issue 31-05-2018
Dt: 12-06-2018	Dt:	Year:			



silica gel to AA55619 or VCI Powder/Tablets, packed in thin muslin cloth cotton bags shall be suitably placed. Small machines/components of less weight shall be provided with suitable cushioning by Rubberised coir. The components inside the case shall be entirely covered with 70GSM(Colourless) Multi Layered Cross Laminated Polyethylene Film Specification No. AA51420, wherever required.

### **3.5 'CR' - Case Packing - Electrical & Electronic Components/Assemblies**

Delicate components likely to be damaged e.g. Gauges, Instruments etc. are to be wrapped in waxed paper or polyethylene air bubble film and packed in cartons. Adequate quantity of Silica gel to AA55619 packed in cotton bags of 100grams each are to be suitably placed in the cartons. The cartons shall be entirely covered with 70GSM(Colourless) Multi Layered Cross Laminated Polyethylene Film Specification No. AA51420 before being packed in the cases. VCI Powder/Tablets can be used as an alternative to Silica Gel to AA 55619.

Empty space in the cartons shall be filled with rubberized coir to get proper cushioning effect. The cartons shall be manufactured from corrugated Fiber Board, meeting requirements of AA51414.

## **4 PREPARATION OF PACKING CASES**

### **4.1 DOMESTIC:**

Based on the availability, the wood shall be Rubber wood (Havea Brasiliensis)/Pine wood for packing of cubicles, loose items, spares and photovoltaic items meant for customers in India.

### **4.2 DIMENSIONS:**

- a) Thickness of planks for Front, rear, top and bottom sides and binding, jointing battens shall be 25 +2/-3 mm.
- b) Width of all planks including the tongue shall be more than 125mm and after planing it shall be minimum 100mm.
- c) Minimum number of planks shall be used for a shooK.
- d) Horizontal, vertical, diagonal planks shall be given for binding (number of such planks depend on the dimension of panel).
- e) External sides of front and rear planks to be planed to facilitate writing of address and other markings.
- f) Width of binding planks shall be minimum 100mm.
- g) Distance between any 2 binding planks shall be less than 750mm.
- h) diagonal planks shall be used in between vertical binding planks when distance between inner to inner of vertical planks is more than 750mm
- i) Distance of the outer edges of these planks from the edge of case shall be less than 250mm.
- j) Diagonal planks are not required for top planks and width side, if the width of pallet is less than 750mm.

### **4.3 JOINTING OF PLANKS**

Single length planks shall be used for cubicles whose overall length is less than 2400mm. For cubicles of length more than 2400mm, jointing is permitted. The jointing shall be done with one single or maximum of 2 planks of wood same as other planks of width 250 mm (minimum) with two rows of nails on either side of the joint in zigzag manner. From the joint along height side, it shall be of lap joint with overlap of at least the width of plank.

### **4.4 TONGUE AND GROOVE JOINTS**

Two Consecutive planks shall be joined by tongue and groove joint. Depth of tongue shall be 12+1 mm, thickness of tongue shall be 8 +1 mm. The groove dimensions shall be such that the tongue fits tightly into the groove to make a good joint. This type of joint can be done based on the product requirement wherever required.

### **4.5 PERMISSIBLE DEFECTS**

Wood shall be free from knots, bows, visible sign of infection and any kind of decay caused by insects, fungus, etc.



## CORPORATE STANDARD

AA0490010

Rev. No. 01

PAGE 3 of 26

**End splits:** Longest end splits at each end shall be measured and lengths added together. The added length shall not exceed 60mm per meter run of shooks. Wood pins shall be used to prevent further development of split.

**Surface cracks:** Surface cracks with a maximum depth of 3mm are permissible. A continuous crack of any depth all along the length is not allowed.

### 4.6 CHEMICAL TREATMENTS FOR PRESERVATION OF WOOD

- 1) This treatment provides protection to the packing wood against deterioration due to fungi and attack by termites, borers and marine organism and any kind of infections.
- 2) The wooden planks, after making tongues / grooves shall be treated with chemicals. For pine wood, treatment with ASCU/ CCA solution need not be done.
- 3) The chemical used shall be ready mix ASCU paste. This consists of Arsenic pent oxide, copper sulphate sodium dichromate. This Paste shall be mixed at the rate of 1 kg of paste per 10 liters of water to the extent of water used. Alternate this CCA paste as mentioned at Para 4.6.5) can also be used.
- 4) The chemical treatment shall be done at the premises of the contractor. A cement concrete tank of capacity to hold a minimum of 2000liters of solution shall be constructed. The solution shall be prepared in the presence of BHEL Representative by contractor. The wooden planks shall be soaked in the solution for a minimum of 12 hours. The solution shall be replenished after treating a maximum of 12 cubic meters of wood. A log book shall be maintained by the contractor to give the details of date of preparation of solution, quantity of solution prepared, quantity of chemicals used, Quantity of wood treated and the details of replenishment. Samples of solutions before mixing will be tested at the laboratories designated by BHEL. The testing fees to be paid to the laboratories will have to be borne by the contractor. The paste shall be tested as and when required.
- 5) Specifications for water soluble type wood preservatives: Copper – Chromium – Arsenic [CCA]: Copper – Chromium – Arsenic preservative formulation shall be as per IS:10013 Part – II – 1981 shall consist of following active ingredients in nominal proportions by weight as shown below:

– Arsenic Pent oxide	AS <sub>2</sub> O <sub>5</sub> 2H <sub>2</sub> O	12.5
– Copper Sulphate	CuSO <sub>4</sub> 5H <sub>2</sub> O	37.5
– Sodium Dichromate	Na <sub>2</sub> Cr <sub>2</sub> O <sub>7</sub> 5H <sub>2</sub> O	50.0
– Or Potassium Dichromate	K <sub>2</sub> Cr <sub>2</sub> O <sub>7</sub>	

### 4.7 OTHER MATERIALS

#### 4.7.1 NAILS

The dia. of the nails shall be 3.15mm. The length of the nails shall be 65mm wherever two planks of 25mm thickness are joined and 75mm wherever a 25mm planks is joined to a 50mm plank.

#### 4.7.2 BLUE NAILS

These are used for nailing bituminized Kraft paper/hessian cloth to the planks. The length of the nails shall be 16mm.

#### 4.7.3 HOOP IRON STRIPS

These are used for strapping the boxes. The width of the strips shall be 19+1mm and thickness 0.6 +0.01mm. The material shall be free from rust.

#### 4.7.4 CLIPS

These shall be used for strapping the hoop iron strips on the boxes.

#### 4.7.5 BRACKETS

These brackets are used for nailing to the corners of cubicle boxes. The brackets shall be of mild steel of thickness min 2mm and width 25+1mm. The brackets shall be of "L" shape, the length of each side being 100+2mm. Two holes shall be provided towards the end of each side for screwing /nailing.

**4.7.6 FASTENERS**

Bolts, double nuts, spring washers will have to be used for packing of some special items like transformers, reactors, breakers, etc., to hold the job to the bottom plank of the box. The bolts, nuts, washers will be provided by the vendor. Drilling of holes will have to be done using contractor's tools.

**4.7.7 MULTI LAYERED CROSS LAMINATED POLYTHELENE FILM**

70GSM (Colourless) Multi Layered Cross Laminated Polythelene Film Specification No: AA51420 are used to make covers to the jobs individually. The cross lamination gives qualities of extra toughness, together with flexibility and lightness coupled with good weather resistance to ultra violet rays.

**4.7.8 RUBBERISED COIR:**

The rubberized coir is used as cushioning material. For the packing of loose items, items are to be arrested by using rubberized coir. For the packing of cubicles rubberized coir of thickness 25mm and width 75mm shall be used.

**4.7.9 FOAM RUBBER / 'U' FOAM:**

This is used for covering the delicate items. This material is provided by the vendor.

**4.7.10 MARKING PLATE:**

This shall be of anodized aluminium sheet. Details and specifications are given in Fig-4

**4.7.11 PACKING SLIP HOLDER:**

This shall be of galvanized iron tinned sheet /Aluminium sheet

**4.7.12 SILICA GEL:**

This shall be of indicating type to conform to IS: 3401/AA55619.

**4.7.13 COTTON BAGS:**

These are used for holding silica gel. The bags shall have the following matter indicated on them:

---

BHEL-UNIT NAME	PLACE-PINCODE
SILICA GEL	INDICATING TYPE
BLUE :	ACTIVE
ROSE :	REDUCED ACTIVITY
WHITE :	NO ACTIVITY. TO BE REPLACED WITH FRESH SILICA GEL

---

**4.7.14 COTTON/ PLASTIC TAPE:**

This is used for tying small items. And also to prevent vibrations of moving parts within the cubicles.

**4.7.15 MARKING INK:**

The ink used normally is black in color. In some special cases other color also will have to be used. The ink shall be non-fading/indelible and non-washable by water.

**4.7.16 POLYETHYLENE BAGS:**

These are to be used for keeping the Packing slips. The bag shall be of size 70mm X 100mm (minimum).



## CORPORATE STANDARD

AA0490010

Rev. No. 01

PAGE 5 of 26

**4.7.17 Hessian cloth, twine thread, paint will have to be used in packing certain items.**

**4.7.18 Mechanical Latching clamps:**

For CLW Railway panels and similar Panels self-locking clamps can also be used on need basis in conjunction with or apart from regular bolt and nut fixing arrangement. For reusable boxes, these clamps provide easy locking and unlocking arrangement. These clamps will be made available from BHEL in some cases.

**4.7.19 STICKERS**

The following stickers to be put by the vendor on cubicles/Boxes after packing.

1. Case No sticker: 2 nos. Size 25.Cm x 0.45Cm
- 6) BHEL Monogram sticker: 1 no. Size 1.75Cm x 2.3Cm
- 7) Address sticker: 2 nos. Size 3.8Cm x 3.0Cm
- 8) Direction sticker " Front " & " Back " - 4 nos. Size 2.0Cm x 0.75Cm
- 9) Chain Mark Sticker: 4 Nos. Size – 3.0Cm x 0.75Cm
- 10) "Fragile " sticker: 2 Nos Size. 2.1Cm x 1.5Cm
- 11) "DO NOT STACK " sticker - 2 Nos. Size 3.0Cm x 2.2Cm

**5 PACKING OF CUBICLES WITH RUBBER WOOD:**

**5.1** The packing is to be done as per clause 4 in all respects.

**5.2** The cubicles are already fixed on wooden pallets. Hence the contractor need not arrange the bottom pallets normally.

**5.3** The cubicles will be of different sizes both widthwise and lengthwise. The cubicles may be made up of single suite, 2 Suite, 3 Suite, 4 Suite, etc., The width of the cubicles generally varies from 400 mm to 1650mm. The length of the cubicle, generally varies from 1500 mm to 4800 mm. The height is normally 2430 mm. In some cases, the height may be less/more.

**5.4 MULTI LAYER CROSS LAMINATED POLY FILM**

The inner surface of 4 sides of shoo's shall be nailed with Multi-layer cross laminated poly film (as per 4.7.7) using blue nails (as per 4.7.2) wherever 2 pieces of Cross laminated poly film are used, the joint shall have an overlap of minimum 20mm.

The inner surface of top cover shall be nailed with Multi-layer cross laminated poly film (as per 4.7.7). This sheet shall project outside on 4 sides by at least 100mm and shall be nailed properly on sides. Joining of sheets should have overlap of minimum 20mm.

The cubicles shall be covered with Multi-layer cross laminated poly film (as per 4.7.7).

**5.5 SILICA GEL:**

Silica gel (as per 4.3.15) packed in cotton bags shall be kept at different places inside the cubicle as per BHEL-Unit directions. Each suit of cubicle shall be provided with 1 kg of Silica gel (for a 4 suit cubicle 4 kgs of Silica Gel to be used. The bag containing silica gel to be as per 4.7.13).

**5.6 LOOSE PARTS:**

Any loose parts in the cubicles shall be tied using cotton/ plastic tape. Wooden battens shall be provided wherever necessary.

**5.7 WOODEN BATTENS:**

In case of cubicle which are not rectangular in shape like control desks, sufficient number of wooden rafters/battens of proper size shall be provided to give strength to the package.

**5.8 RUBBERISED COIR:**

Gap between the cubicle and the case shall be filled with rubberized coir (as per 4.7.8) with distance between consecutive layers less than 500mm.

**5.9 CLAMPING:**

Packing shall be bound at edges by nailing M.S. Clamps / Brackets (as per 4.7.5). Each vertical edge shall have minimum 3 clamps. Top horizontal edges will have one clamp for every meter length of package. However, minimum 4 clamps shall be nailed at the top for any cubicle.

**5.10 PACKING SLIP:**

Packing slip kept in the polyethylene bag (As per 4.7.16) shall be placed in the box at appropriate place. In addition, one more packing slip covered in polyethylene cover and packing slip holder (as per 4.7.11) shall be nailed to front / rear of case.

**5.11 MARKING PLATE:**

One no. (As per 4.7.10) shall be nailed to the front side of the case.

**5.12 CASE MOUNTING:**

After complete packing, stencil marking of various details and marking of symbols shall be done as per BHEL instructions using indelible / non washable marking ink.

**5.13 Different types (Typical) of Cubicles with sizes for Packing**

1. Single suite cubicle - 900 x 950 x 2500
2. Two suite cubicle - 1650 x 950 x 2500
3. Three suite cubicle - 2400 x 950 x 2500
4. Four suite cubicle - 3150 x 950 x 2500
5. Regulation cub - 1300 x 1350 x 2500
6. Thy cub - 2870 x 1350 x 2500
7. VFD Cub - 3800 x 1550 x 2500

**5.14 PACKING OF CUBICLES WITH PINE WOOD**

Packing of cubicles for export shall be done exactly in same manner as described at Cl.No 5 except for the following changes: -

Wood shall be Silver oak/ Pine wood instead of rubber wood.

- Double polyethylene petticoat instead of one.
- Fumigation may have to be done if required (BHEL Scope).

**6 PACKING OF LOOSE ITEMS/SPARES USING RUBBER WOOD:**

- 1) Shape of cases shall be square, rectangular with single gabled roof or with double gabled roof depending on the nature of the job to be packed. Construction shall be as per drawings enclosed. Only gable will be additional as required.
- 2) Wood shall be rubber wood with Tongue and Groove joint as per clause 4.4.
- 3) Chemical treatment as per Clause 4.6 to be done.
- 4) Width of planks shall be at least 100 mm. Width of binding planks (battens) shall be at least 75mm.
- 5) External surface of planks on front and rear shall be plane 100% (except bottom plank).
- 6) Inner surfaces of all 6 sides shall be lined with bitumen coated hessian polyethylene Kraft paper (as per clause 4.7.7) using blue nails.
- 7) Rubberized coir of minimum 25mm thickness and 100 mm width shall be nailed to inner surfaces of bottom and 4 sides of box.
- 8) Internal packing: Items that go into the box shall be packed using 70GSM, (Colourless) Multi Layered Cross Laminated Polyethylene Film Specification No: AA51420. Any space left Between the job and the sides and the top of the box shall be filled with rubberized coir to get proper cushioning effect .
- 9) Certain items like transformers, reactors, breakers, etc., shall be bolted to the bottom of the box using bolts, nuts and washers.



# CORPORATE STANDARD

AA0490010

Rev. No. 01

PAGE 7 of 26

- 10) Silica gel as per clause 4.7.12 held in cotton bags as per clause 4.7.13 shall be kept at proper places in the box.
- 11) Packing slip kept in polyethylene bag (clause 4.7.16) shall be placed in the box.
- 12) Marking plate as per clause 4.7.10 shall be nailed to side of the box.
- 13) Two numbers of hoop iron strips as per clause 4.7.3 shall be strapped tightly on the case using clips.
- 14) Stencil marking of various details and marking of various symbols shall be done as per BHEL instructions using indelible/non-washable marking ink.
- 15) Loose items to be kept inside the cubicle
  - The components which are removed from cubicle for shipping purpose only, such as meters shall be kept inside the cubicle individually, kept in wooden box and tied firmly in bottom of Cubicle.
  - Other items which are given loose in addition to cubicle shall be packed in separate boxes.

## 7 BOX SIZES

### 7.1 BOX SIZES

**Table 1 – SPARES WOODEN BOX DETAILS**

SNO	BOX TYPE	BOX SIZE (in mm)	BOX Wt (in KG)	Carrying Capacity
1	A	800 X 200 X 200	15	
2	B	1500 X 200 X 200	22	
3	C	2000 X 200 X 200	27	
4	D	1100 X 200 X 200	15	
5	E	200 X 200 X 200	5	
6	F	320 X 250 X 260	13	
7	G	320 X 250 X 430	16	
8	H	430 X 370 X 430	23	
9	I	1100 X 400 X 400	45	
10	J	1500 X 500 X 400	65	
11	K	2000 X 500 X 400	93	
12	L	2500 X 500 X 400	88	
13	M	900 X 600 X 600	100	
14	N	3000 X 400 X 400	60	
15	P	600 X 500 X 400	35	
16	Q	710 X 630 X 600	90	
17	R	850 X 630 X 670	102	
18	S	1000 X 770 X 670	140	
19	T	2500 X 850 X 800	180	
20	U	1500 X 700 X 700	120	
21	W	1200X900X600	120	
22	Y	450 X 200 X 200	10	

**7.2 BOX SIZES****Table 2 – VALVES WOODEN BOX DETAILS**

BOX TYPE	BOX SIZE (in MM)	BOX Wt (in KG)	Carrying Capacity
1A	320X250X260	10	
1	320X250X430	15	
2	430X370X430	25	
3	670X670X470	65	
4	720X630X600	75	
6	1000X770X660	100	
7	1100X430X670	80	
8	1200X1200X900	80	
10	1300X770X1050	155	
11	2500X850X800	225	
12	2000X1500X1200	305	
14	1850X1050X1250	260	
15	2000X800X800	180	
17	2600X1500X1600	470	
21	250X250X600	20	
22	250X250X880	30	
23	300X300X700	25	
24	380X380X880	45	
25		25	
26	510X510X1400	60	
27	570X570X1400	80	
28	575X575X1875	105	
29	3600X1100X1100	390	
30	900X500X800	110	
52	2000X950X740	225	
53	1600X1120X700	220	
54	2500X2000X1200	490	
55	2900X1900X1400	525	
56	3000X1000X900	370	
57	3200X2200X950	450	
58	2150X1100X750	325	
61	2000X2000X700	130	
62	700X1200X1325	130	

**TYPICAL PATTERN OF WOODEN BOX**

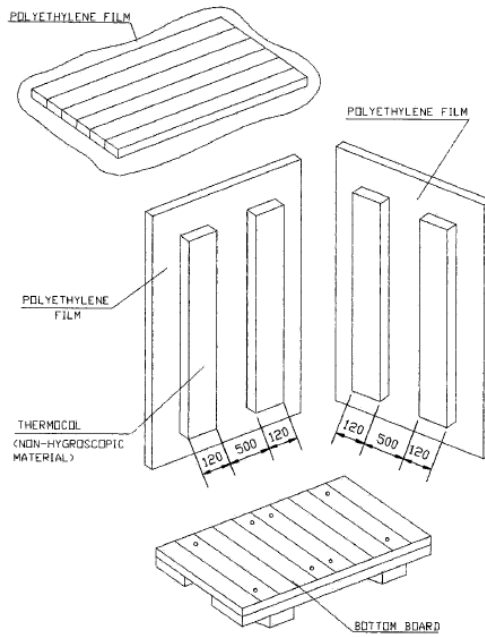

**Figure 1**

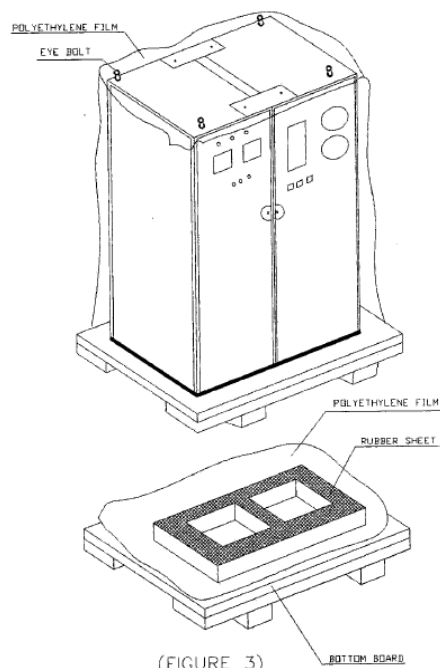

(FIGURE 3)

**Figure 2**

**7.3 STANDARD BOX SIZES****WOODEN BOXES:**

SL NO	TYPE	DIMENSION IN MM			WEIGHT	CARRYING CAPACITY (KGS)
		LENGTH	BREADTH	HEIGHT		
01	I	2370	1570	1650	675	4000
02	IIA	1570	720	885	200	2500
03	II	1200	900	600	150	2000
04	III	900	600	600	100	1000
05	IV	600	450	450	40	750
06	V	600	300	300	35	500

**STEEL BOXES:**

SL NO	TYPE	DIMENSION IN MM			WEIGHT	CARRYING CAPACITY (KGS)
		LENGTH	BREADTH	HEIGHT		
07	I	2480	1680	1500	339	4500
08	II	1200	900	600	061	2000
09	IIB	1800	850	950	115	2500
10	III	900	600	600	029	1000
11	IV	600	450	500	019	750
12	V	400	350	300	011	500

**Table 3****7.4 STEEL CONTAINERS**

Steel containers for packing can be used in case of repeated supplies of the same equipment. Empty steel containers are to be returned back from customer's end and to be reused for the next supplies. The containers are to be made of structural steel as per AA10108 with proper reinforcement with I, C and T Sections.

- a) Following precautions are to be taken during packing: -
- b) Put the machine in the steel container properly,
- c) Cover the machine with polythene.
- d) To arrest the movement in the steel container necessary wooden Blocks/Battons may be put.
- e) Put cover on steel, container and Bolt Properly

**8 MARKINGS/STENCILINGS**

**MARKINGS ON PACKING CASES**

1. THIS PLANT STANDARD PRESCRIBES THE VARIOUS CAUTION SIGNS AND OTHER MARKINGS ON PACKING CASES.
2. DIMENSIONS IN THE TABLE 1 SHALL BE USED FOR MAKING STENCILS ONLY.

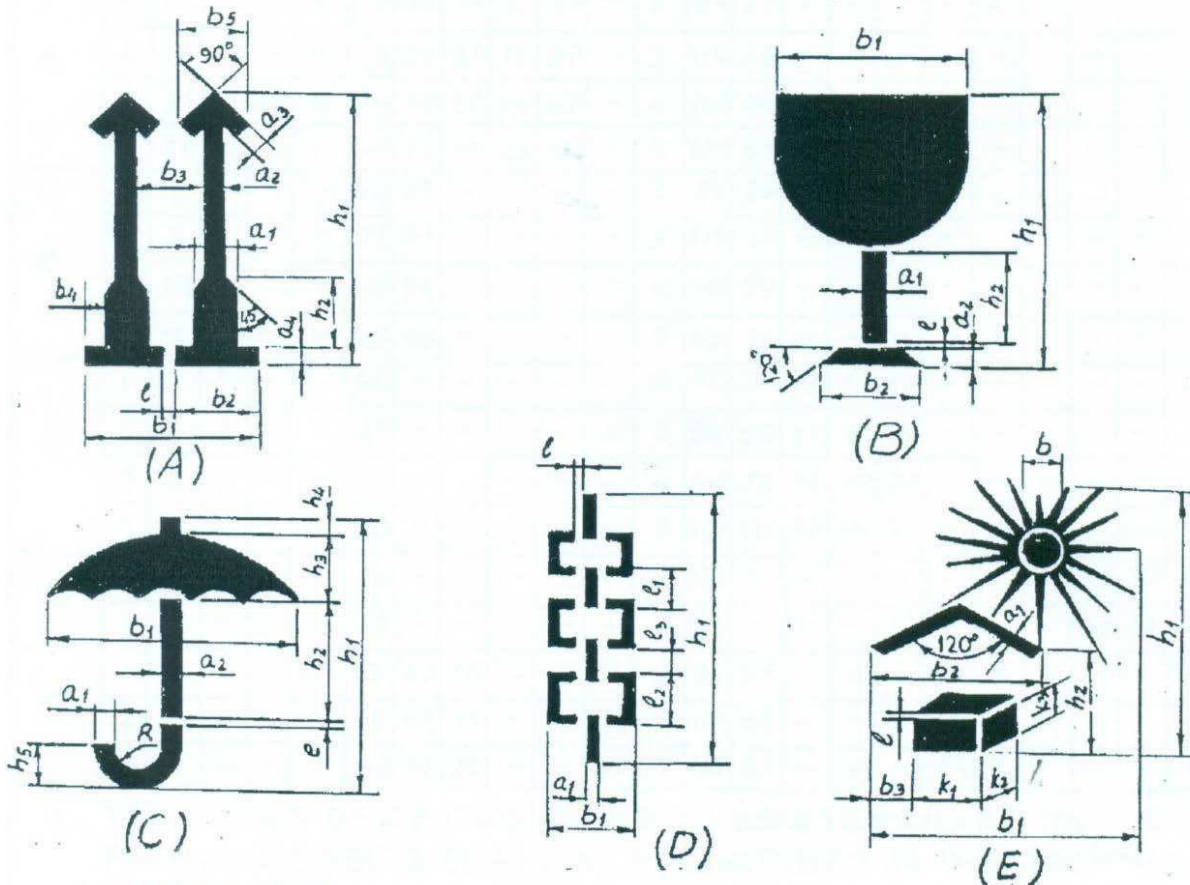

- A. UPRIGHT
- B. FRAGILE
- C. PROTECTION FROM FALLING OR CONDENSING MOISTURE.
- D. SLINGING POSITION
- E. PROTECTION FROM DIRECT RADIATIONS.

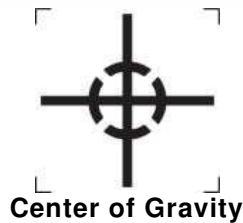

Figure 3



DESIGN- ATION		DIMENSION IN MM																						
		a1	a2	a3	a4	b1	b2	b3	b4	b5	b	l	h1	h2	h3	h4	h5	k1	k2	k3	l1	l2	l3	R
A	1	12	5	5	4	52	25	19	8	21		2	84	23										
	2	17	7	7	6	75	36	29	11	30		3	119	33										
	3	24	10	10	8	104	50	38	16	42		4	168	46										
	4	34	14	14	11	147	71	59	23	60		5	239	65										
B	1	5	5			50	33					2	84	25										
	2	7	7			71	47					3	119	36										
	3	10	10			100	66					4	168	50										
	4	14	14			142	94					5	239	71										
C	1	4	3			66						2	80	39	19	5	11							6
	2	6	4			85						3	114	55	27	7	16							9
	3	8	6			120						4	160	78	38	10	22							12
	4	11	9			170						5	227	110	54	14	31							17
D	1	6				30						4	148									30	30	10
	2	9				42						5	209									42	42	14
E	1	3				69	47	10			16	2	91	26				17	8	11				
	2	4				98	67	15			23	3	128	33				24	11	16				
	3	6				138	94	20			32	4	182	62				34	16	22				

Table 4

Black and Red Marking Ink to IS:1234 "Ink, Stencil, Oil Base, For Marking Porous Surfaces" or duplicating ink stencilling, oil base for marking porous surfaces.

All cases containing fragile items are to be stencilled with red marking and stencilling paint/ink

**"HANDLE WITH CARE", "FRAGILE DO NOT TURN OVER".**

Besides the caution signs the product information's shall be stencilled of letters with 13mm to 50mm height.

In case of consignment consists of more than one package, each package shall carry its package no as given in shipping list. All caution signs shall be stencilled in high quality full glossy out door finishing paint red in colour (AA56126). All other markings shall be carried out in black enamel(AA56126).

Caution signs & other markings shall be stencilled on both the end shooks & the side shooks.

Caution sign (for slinging) shall be stencilled only on side shooks at the appropriate place.

Note: In case the size of package is small for using the stencils, then hand written letters/figures shall be allowed.

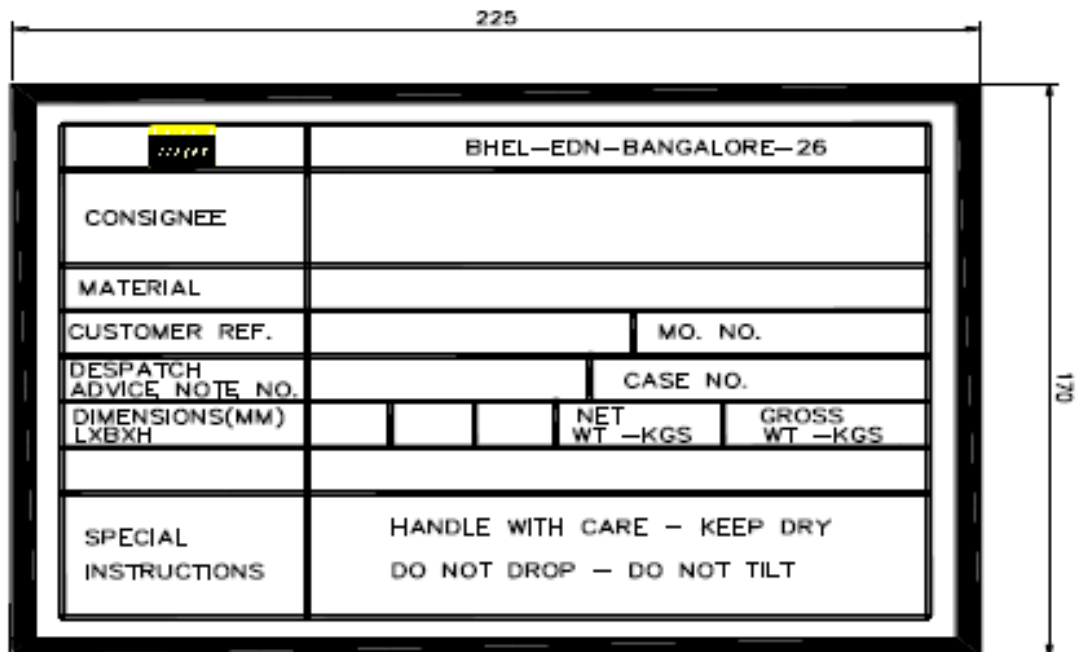

**Figure 4 – TYPICAL MARKING PLATE**

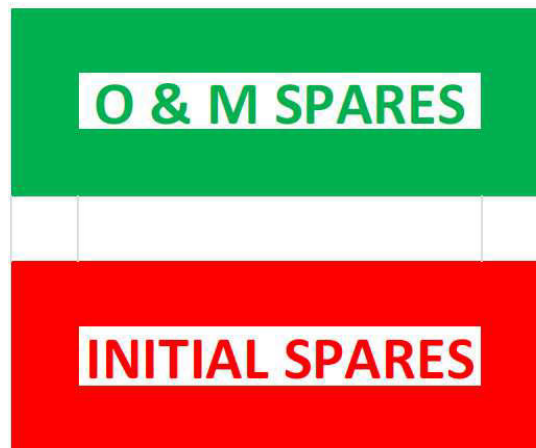

**Figure 5**

**Easy spares [Initial and O&M ] Traceability and Identification at units and as well as at sites:**

**9 RECYCLING OF INCOMING WOODEN PACKING CASES**

**OBJECTIVES**

- To utilize useable wood of incoming packing cases, for manufacturing of new packing boxes.
- To recycle incoming wooden packing cases, as such, wherever possible.











- 11.8.1** Appropriate cranes and slings should be used for different components/ cases. Slings should normally make an angle as minimum as possible (width wise) but in no case more than 15°.
- 11.8.2** Handling and lifting should be done without jerks or impacts.
- 11.8.3** Immediately after receipt of the goods, the packing should be examined all-round for any sign of damage. If necessary, lift the cover or a number of boards of the case so as to make the contents visible. In the event of sealed packing being used the plastic sheeting should not be damaged. It is imperative that the packing material is restored in original condition after the inspection.
- 11.8.4** On receipt of the equipment it should be checked with the shipping list and missing or damage if any should be reported immediately. It is important to arrange for immediate examination to determine the extent of the damage, the cause of the damage and where applicable the person or persons responsible for the damage. According to general practice when transporting by railway or by road vehicle the carrier concerned should be immediately called upon (within specified periods) for jointly establishing a statement of the damage. This is essential as a basis for a subsequent claim and possible damage report to the insurance company.
- 11.8.5** Protective coating applied on machined surfaces should not be disturbed. The plastic covering should be put back carefully so that it prevents ingress of dust and moisture. Some packing may have vapour phase inhibitor (VPI) paper enclosed inside the packing cases. This should be restored to its original place as far as possible.
- 11.8.6** Silica gel and such other chemicals kept in the box as desiccants and indicators should also be left in the box itself.

## **12 GENERAL GUIDELINES FOR ODC TRANSPORTATION/DESPATCH**

Based on the Dimensions/Weight indicated in the Transportation Sketch, the type of Trailer is decided and indicated in the Tender Enquiry.

### **12.1 TRANSPORTATION:**

#### **1. LOW BED TRAILERS (LB 8):**

Well Bed Length:	10000mm
Over Gooseneck:	13000mm
Width:	3000mm
Carrying Capacity:	40MT

#### **2. LOW BED TRAILERS (LB 16):**

Well Bed Length:	12000mm
Over Gooseneck:	16000mm
Width:	3000mm
Carrying Capacity:	75MT

#### **3. TOW TYPE TRAILERS (WITH FRONT DOLLEY 16 TYRES): 12000MM length (for Exceptional equipment length: 30000mm and above)**

Bigger Dia equipment are loaded in the Well with overhanging.

Smaller Dia equipment with excess length are loaded over Gooseneck with rear hanging.

The Vehicle Dimensions are defined above are only guidelines for selection based on actual Dimensions/ Weight of the Consignment

### **12.2 PACKING:**

For all ODCs, Wooden Saddles are cut to the diameter of equipment as per the Transportation Sketch.

For Diameter up to 4000mm

Wooden Saddles Length: 1836/2743mm (6'0"/9'0")  
 Width: 300mm (1'0")  
 Height: Saddle + one/two wedges a top.

For Diameter up to 4000mm

Wooden Saddles Length: 3353mm (11'0")  
 Width: 300mm (1'0")  
 Height: Saddle + three/four wedges a top.

**NUMBER OF SADDLES:**

Minimum: 3 in case of Loading inside Well  
 + 1 when loaded on Gooseneck.  
 Maximum: 4 in case of Loading inside Well  
 +2 when loaded on Gooseneck.

For Securing the equipment firmly on the Trailer, 19mm (3/4"), wire rope with 25mm (1") Heavy Duty Turn Buckles / BD Clamps are used as Lashing for the equipment.

**12.3 NUMBER OF LASHINGS ARE:**

	CONSIGNMENT LOADED INSIDE WELL BED	CONSIGNMENT LOADED OVER GOOSENECK
a) up to 40MT	4 (2 Single Line lashing 2 Double Line Lashing)	5 (3 Single Line Lashing 2 Double Line Lashing)
b) 40MT to 60MT	5 (3 Single Line Lashing 2 Double Line Lashing)	5 (Single Line Lashing 3 Double Line Lashing)
c) 60MT and above	5 (2 Single Line Lashing 3 Double Line Lashing)	6 (3 Single Line Lashing 3 Double Line Lashing)

**13 GUIDELINES FOR HANDLING/LOADING/LASHING**

**13.1 HANDLING**



**Figure 6**

Before unloading the jobs Completely painted and neatly stencilled will be checked.

Pipes with split type end cover will be checked

**Figure 7**

All Coil Tubes to be provided with End Caps.

**Figure 8**

Neatly stacked Coil Assemblies.



**Figure 9**

Columns to be lifted with Nylon belts. This protect painting, edges and attachments.



**Figure 10**

### **13.2 LOADING**

All the components to be transported by putting inside the properly fabricated Crating



Figure 11

Small components may fall down while transporting without closed crating and there are chances of missing of small parts. Hence, it is always better to transport small components in closed containers/crating. Loose to be being shipped in a closed crating.



Figure 12

No component loaded over the crating.



**Figure 13**

Headers supported with wooden V blocks at 3 meters interval.



**Figure 14**

Spacers in between each coil assembly.

**Figure 15**

Goose pipe to be provided with rubber pad protects removal of painting and damage to the job.

**Figure 16**

### **13.3 LASHING**

Use Nylon belts only for lashing of all components. It prevents removal off painting and cut in the materials.



**Figure 17**

Nylon Belts used for lashing the beams.



**Figure 18**

#### **14 PRODUCT WISE SPECIAL INSTRUCTION**

Additional instructions of packing not included in this standard shall be covered by individual product standard

**15 REFERRED STANDARDS (Latest publications including amendments):**

- |            |            |            |            |
|------------|------------|------------|------------|
| 1) AA51420 | 2) AA55619 | 3) AA51414 | 4) IS:3401 |
| 5) AA10108 | 6) AA56126 |            |            |



**COPYRIGHT AND CONFIDENTIAL**

The information on this document is the property of **BHARAT HEAVY ELECTRICALS LIMITED**,  
It must not be used directly or indirectly in any way detrimental to the interest of the company.

# **Annexure-6**

## **FORMAT FOR PRE QUALIFICATION CRITERIA**

**Revisions:**  
Refer to record of revisions

Sl. No.	Description	Rev. No.	Date

**ANNEXURE-6-I: EXPERIENCE RECORD PROFORMA**

<b>S.No.</b>	<b>Description</b>	<b>Reference Project-1</b>	<b>Reference Project-2</b>
1.	Name of Customer		
2.	Service / Working Fluid / Application		
3.	Type of Air Blower		
4.	Model No. of Air Blower		
5.	Quantity of Equipment / Systems Supplied		
6.	Capacity (Flow and Head)		
7.	Rating of Motor (kW)		
8.	Material of Construction		
9.	PO No. & Date		
10.	Enclosed Purchase Order / LOI / Invoice / IRN & Date (Yes / No) (Refer Cl.No.A.1.(a) )		
11.	Enclosed MRC / Site Inspection Report / Performance certificate (Yes / No) (Refer Cl.No.A.1.(b) )		
12.	Enclosed Project document (Yes / No) (Refer Cl.No.A.2.(a) )		
13.	Year of Commissioning		
14.	Remarks		

ESP-001-  
2A Rev.00



**PROJECT ENGINEERING & SYSTEMS DIVISION**

Std. / Doc. Number

Rev. No. 00

**COPYRIGHT AND CONFIDENTIAL**

The information on this document is the property of **BHARAT HEAVY ELECTRICALS LIMITED**,  
It must not be used directly or indirectly in any way detrimental to the interest of the company.

**Annexure-7**  
**Quality Related Document**

**Revisions:**  
Refer to record of revisions

Rev. No.	Description	Rev. No.	Description	Rev. No.	Description



## QAP GUIDELINES & FORMAT

( ANNEXURE)

The QAP format and guidelines for filling up the format shall be used by vendor for preparation and submission of QAP after order placement.

**Note :**

1. Typical /Indicative /Standard QAP(s) for equipment /package attached is reference document and to use by successful bidder in future for preparation and submission of QAP for BHEL /CUSTOMER approval.
2. No deviation to reference document is acceptable.

**COPYRIGHT AND CONFIDENTIAL**

The information on this document is the property of BHARAT HEAVY ELECTRICALS LIMITED,  
It must not be used directly or indirectly in any way detrimental to the interest of the company.

Form No.	 <b>HYDERABAD</b>	<b>PRODUCT STANDARD</b> PROJECT ENGINEERING & SYSTEMS DIVISION HYDERABAD	ANNEXURE Rev No. 00 Page 2 of 3
<b>COPYRIGHT AND CONFIDENTIAL</b> The information on this document is the property of BHARAT HEAVY ELECTRICALS LIMITED . It must not be used directly or indirectly in any way detrimental to the interest of the company.	<p><b><u>GUIDELINES TO VENDORS FOR PREPARATION OF QUALITY ASSURANCE PLAN</u></b></p> <ol style="list-style-type: none"> <li>1. QAP shall be made in landscape mode on A4 size paper as per the format enclosed. Font size shall be minimum 10.</li> <li>2. Each page of QAP shall contain the following information.           <ol style="list-style-type: none"> <li>a) Vendor's name &amp; address.</li> <li>b) Customer: BHEL, Hyderabad.</li> <li>c) Project.</li> <li>d) BHEL Product Standard Number/revision number as referred in P.O.</li> <li>e) BHEL Purchase Order Number &amp; Date.</li> <li>f) Product as per P.O. description.</li> <li>g) QAP Number (unique and shall not repeat)/revision number/date.</li> <li>h) Page number and number of pages</li> </ol> </li> <li>3. QAP shall contain four parts / stages as follows.           <ol style="list-style-type: none"> <li>a) Raw materials and bought out items.</li> <li>b) In process Control / Inspection.</li> <li>c) Final assembly, Inspection &amp; Testing.</li> <li>d) Painting, preservation &amp; packing.</li> </ol> </li> <li>4. Under 'Component', indicate name of the component (say casing, rotor, pressure gauge, etc).</li> <li>5. Under 'Characteristics', indicate appropriately (say chemical analysis, mechanical properties, NDT (UT,DP etc.), hydrostatic test, calibration check etc.)</li> <li>6. Under 'Class', indicate minor, major or critical depending on the importance of characteristic.</li> <li>7. Under 'Type of check', indicate appropriately (say chemical, mechanical, UT, DP etc.)</li> <li>8. Under 'Quantum of check', indicate appropriately (say 100%, 10%, sample, per melt, per heat, all pieces etc.)</li> <li>9. Under 'Reference document' and 'Acceptance norms', appropriate National &amp; International standards, BHEL standards, approved drawing references etc. should be indicated. It is not correct to mention as "Vendor's internal standards or Vendor's standard practice etc.". If vendors' internal standards are referred, same shall be in line with BHEL Spec. indicated in the P.O. These may require review &amp; approval by our Engineering dept.</li> <li>10. Under 'Format of record', indicate appropriately supplier's test certificate, calibration certificate, lab report, inspection report etc.</li> </ol>		
Ref. Doc	<ol style="list-style-type: none"> <li>11. Please refer 'Agency' in QAP format.            Under P: Perform, W: Witness, V: Verify            Indicate against each characteristic 1: (BHEL CQS/Nominated inspection agency), OR            2: (Vendor / Sub vendor)</li> </ol>		

Form No.	 HYDERABAD	<b>PRODUCT STANDARD</b> PROJECT ENGINEERING & SYSTEMS DIVISION HYDERABAD	ANNEXURE Rev No. 00 Page 3 of 3
<b>COPYRIGHT AND CONFIDENTIAL</b> The information on this document is the property of BHARAT HEAVY ELECTRICALS LIMITED . It must not be used directly or indirectly in any way detrimental to the interest of the company.	<p>Note: Performing agency is normally vendor or his sub vendor (Legend 2). Where witness points are indicated in specification, P.O., Drawing etc., for such operations, Under Witness (W) column use 1. Under 'Verify' column, use code 1.</p> <p>12. Under 'D' please put ( <input type="checkbox"/> Tick) against each characteristic where vendor proposes to submit test certificate/report etc. OR as required as per BHEL Specification.</p> <p>13. Vendor's signature &amp; stamp should be available on each page of QAP.</p> <p>14. Vendor should read the BHEL Product Standard thoroughly and QAP should be made only inline and relevant to the Specification &amp; Approved Drawings.</p> <p>15. The following operations/characteristics/check points may be included (AS APPROPRIATE)</p> <ol style="list-style-type: none"> <li>a) Visual check</li> <li>b) Dimensional check</li> <li>c) Mechanical and Chemical properties.</li> <li>d) Surface preparation before painting (by chemical cleaning, sand blasting, shot blasting etc. as the case may be.)</li> <li>e) Painting check for shade, Dry Film Thickness (DFT), Adhesion/ peel off test etc.</li> <li>f) Check for correctness for all components mounted as per General arrangement Drawing, Bill Of Materials (BOM), etc. for range, rating, make, color, size, location as per GA, quantity, label description including tag nos., annunciator facia, loose components, accessories, spares etc.</li> <li>g) Verification of test certificate for protection class for the enclosures.</li> <li>h) Mechanical functioning of switches.</li> <li>i) Continuity of earthing and provision of earth points.</li> <li>j) Colour coding of wiring, size, tightness &amp; dressing of wiring.</li> <li>k) Review of test certificates of assembled items, raw materials, internal test reports etc.</li> <li>l) Witness of functional checks, which may include mechanical run &amp; electrical run, H.V.test, IR measurement, Electrical and Mechanical tests etc.</li> <li>m) PQR, WPS, Welder Qualification Record, welding records (fit up, DP) etc.</li> <li>n) Material identification ( for punch marks of serial numbers, Heat No, Melt No, Inspector's stamp etc.)</li> <li>o) Hydraulic Pressure Test, Pneumatic Pressure Test, Liquid Penetration Examination and other Non-Destructive Tests.</li> <li>p) Tests on Galvanised items (Visual, Hammer Test, Knife Test, Thickness, Pierce Test (Copper sulphate test), Hydrogen evaluation test, Stripping test (for Mass of Zinc coating)</li> <li>q) All tests as per BHEL Product Standard &amp; approved drawings including Type tests and Routine tests on individual items and on System as a whole.</li> <li>r) Packing and Preservation.</li> </ol> <p>16. <b>QAP Format enclosed.</b></p> <p>17. <b>Typical Manufacturing QAP(s) is /are attached.</b></p>		
Ref. Doc			

VENDOR'S NAME & ADDRESS:		<b>MANUFACTURING QUALITY PLAN</b>							QP. NO.:				
		CUSTOMER: BHEL, HYDERABAD – 32.			BHEL P.O.NO.:				REV NO:	DATE:			
		PROJECT:			P.O.DATE:				PAGE 1 OF 1				
		PRODUCT:			BHEL SPEC:				REV:				
SL NO	COMPONENTS	CHARACTERISTICS	CLASS	TYPE OF CHECK	QUANTUM OF CHECK	REFERENCE DOCUMENT	ACCEPTANCE NORMS	FORMAT OF RECORD	* D	AGENCY			REMARKS
										P	W	V	
<b>1.0</b>	<b>RAW MATERIALS &amp; BOUGHT OUT ITEMS</b>												
<b>2.0</b>	<b>INPROCESS INSPECTION</b>												
<b>3.0</b>	<b>FINAL INSPECTION &amp; TESTING</b>												
<b>4.0</b>	<b>PRESERVATION &amp; PACKING</b>												

**VENDOR TO NOTE:** THIS FORMAT IS IN MICROSOFT WORD. HEADER & FOOTER SHALL BE AVAILABLE IN EACH PAGE OF QP. QP SHALL BE IN LANDSCAPE & A4 SIZE ONLY. FONT SIZE SHALL BE MIN 10. VENDOR SHALL SIGN & STAMP IN EACH PAGE OF QP. LOI REF. & DATE ARE NOT ACCEPTABLE. P.O.NO. & DATE SHALL BE INDICATED. QP NO. SHOULD BE UNIQUE AND SHALL NOT REPEAT. ALL THE TESTS / CHECKS INDICATED IN THE BHEL SPEC. SHALL BE INDICATED IN THE QP.

LEGEND: P: PERFORM, W: WITNESS, V: VERIFICATION. INDICATE 1 FOR BHEL CQS (OR BHEL NOMINATED INSPECTION AGENCY) & 2 FOR VENDOR/SUB VENDOR AS APPROPRIATE AGAINST EACH COMPONENT /CHARACTERISTIC UNDER P, W & V COLUMNS. * FOR ITEMS MARKED ✓ (TICK) IN COLUMN 'D', TEST CERTIFICATES SHALL BE SUBMITTED TO BHEL FOR RECORDS.	PREPARED BY	APPROVED BY	APPROVED BY
	VENDOR'S SIGNATURE & STAMP	BHEL QA SIGNATURE & STAMP	CUSTOMER'S SIGNATURE & STAMP

		<b>TYPICAL MANUFACTURING QUALITY PLAN</b>						MQP. NO.:					
PROJECT ENGINEERING & SYSTEMS DIVISION BHEL, RC PURAM, HYD-502032		PROJECT: PACKAGE: <b>AIR BLOWER</b> BHEL TECH SPEC:				REV NO:		DATE:					
										PAGE 1 OF 3			
SL NO	COMPONENTS	CHARACTERISTICS	CLASS	TYPE OF CHECK	QUANTUM OF CHECK	REFERENCE DOCUMENT	ACCEPTANCE NORMS	FORMAT OF RECORD	* D	AGENCY			REMARKS
										P	W	V	
<b>1.0 RAW MATERIALS &amp; BOUGHT OUT ITEMS</b>													
1.1	Body and Cover/Plates	Chemical & Mech. Properties	Major	Chemical & Mech. analysis	1 per heat/lot	Tech Spec/ Approved Datasheet/ Approved Drawing	MTC	√	2	2	1		
1.2	Screw Shaft & Gears	Chemical & Mech. Properties	Major	Chemical & Mech. Analysis	1 per heat/lot		MTC	√	2	2	1		
1.3	Mechanical seal	Material and leakage check (Air test)	Major	OEM's certificate review	100%		MTC / COC	√	2	2	1		
1.4	Bearing and bearing housing	Make and Model	Major	Visual	100%		MTC / COC	√	2	2	1		
1.5	Accessories * (inter connecting piping, strainers, filters, silencers instruments, JB etc.)	Chemical & Mech. Properties	Major	Chemical & Mech. Analysis	1 per heat/lot		MTC	√	2	2	1	* accessories as per scope of supply	
1.6		MOC, hydro test reports, Calibration reports and Type test certificates for instruments.	Major	OEM's certificate review	100%		OEM test certificates	√	2	2	1		
1.7	Safety Relief Valve	Chemical & Mech. Properties	Major	Chemical & Mech. Analysis	1 per heat/lot		MTC	√	2	2	1		
1.8		Hydro Test, Set Pressure Test	Minor	Hydro Test, Set Pressure Test	100%		TC	√	2	2	1		
LEGEND: P: PERFORM, W: WITNESS, V: VERIFICATION. INDICATE 1 FOR BHEL CQS (OR BHEL NOMINATED INSPECTION AGENCY) & 2 FOR VENDOR/SUB VENDOR AS APPROPRIATE AGAINST EACH COMPONENT /CHARACTERISTIC UNDER P, W & V COLUMNS. * FOR ITEMS MARKED ✓ (TICK) IN COLUMN 'D', TEST CERTIFICATES SHALL BE SUBMITTED TO BHEL FOR RECORDS.													

SL NO		COMPONENTS	CHARACTERISTICS	CLASS	TYPE OF CHECK	QUANTUM OF CHECK	REFERENCE DOCUMENT	ACCEPTANCE NORMS	FORMAT OF RECORD	*	AGENCY			REMARKS
										D	P	W	V	
<b>2.0</b>		<b>INPROCESS INSPECTION</b>												
2.1	Fabrication of body and other components	WPS, PQR and WQR	Major	Document verification	100%	Tech Spec/ Approved Datasheet/ Approved Drawing	WPS, PQR and WQR	--	2	2	1			
2.2	Body and Cover/Plates	NDE	Major	DPT/MPI	100%		NDE reports	√	2	2	1			
2.3		Leakage	Critical	Hydro test	100%		Test reports	√	2	1	--			
2.4	Screw Shaft & Gears	NDE and hardness	Major	UT and hardness test	100%		NDE reports	√	2	2	1			
2.5	Rotor assembly	Dynamic balancing	Critical	Balancing	100%		IR	√	2	2	1			
<b>3.0</b>		<b>FINAL INSPECTION &amp; TESTING</b>												
3.1	<u>Air blower assembly</u>	Performance test	Critical	Testing	100%	Tech Spec/ Approved Datasheet/ Approved Drawing	TC	√	2	1	--	Only 10% witness by BHEL / BHEL's TPIA, subjective to minimum 1 pump of		
3.2		Mechanical run test	Critical	Testing	100%		TC	√	2	1	--			
3.3		Strip Examination	Critical	Dismantling	100%		TC	√	2	1	--			
3.4		Overall Dimensions	Major	Measurement	100%		IR	√	2	1	--			

LEGEND: P: PERFORM, W: WITNESS, V: VERIFICATION. INDICATE 1 FOR BHEL CQS (OR BHEL NOMINATED INSPECTION AGENCY) & 2 FOR VENDOR/SUB VENDOR AS APPROPRIATE AGAINST EACH COMPONENT /CHARACTERISTIC UNDER P, W & V COLUMNS. \* FOR ITEMS MARKED √ (TICK) IN COLUMN 'D', TEST CERTIFICATES SHALL BE SUBMITTED TO BHEL FOR RECORDS.

SL NO		COMPONENTS	CHARACTERISTICS	CLASS	TYPE OF CHECK	QUANTUM OF CHECK	REFERENCE DOCUMENT	ACCEPTANCE NORMS	FORMAT OF RECORD	* D	AGENCY			REMARKS
											P	W	V	
3.5			Spares (if any)	Major	BOM check	100%			IR	√	2	1	--	each size & type.
<b>4.0 PRESERVATION &amp; PACKING</b>														
4.1		Air blower and its components	Direction of rotation, Stamping and Painting	Major	Visual, Shade & DFT	Random	Tech Spec/ Approved Datasheet/ Approved Drawing		IR	√	2	1	--	
4.2			Packing #	Major	Visual	100%			Packing List	√	2	2	1	# Seaworthy packing for export orders

**Notes:-**

1. This MQP should be read along with specification ((Latest revisions to be considered as per PO), approved drawings & approved datasheet.
2. Specification/drawing/datasheet shall prevail over quality plan for contradiction if any.
3. Any project/customer specific requirements which shall be notified have to be fulfilled by the vendor at the time of execution of order.

**Abbreviations:-**

MTC –	Material Test certificate	COC –	Certificate of Compliance	DFT –	Dry Film Thickness
TC –	Test Certificate	NDE –	Non Destructive Examination	IR –	Inspection Report
DFT –	Dry Film Thickness	IBR –	Indian Boiler Regulations	IS –	Indian Standards

LEGEND: P: PERFORM, W: WITNESS, V: VERIFICATION. INDICATE 1 FOR BHEL CQS (OR BHEL NOMINATED INSPECTION AGENCY) & 2 FOR VENDOR/SUB VENDOR AS APPROPRIATE AGAINST EACH COMPONENT /CHARACTERISTIC UNDER P, W & V COLUMNS. \* FOR ITEMS MARKED ✓ (TICK) IN COLUMN 'D', TEST CERTIFICATES SHALL BE SUBMITTED TO BHEL FOR RECORDS.



**TYPICAL MANUFACTURING QUALITY PLAN**

MQP. NO.:

PROJECT ENGINEERING & SYSTEMS  
DIVISION BHEL,  
RC PURAM, HYD-502032

PROJECT:  
PACKAGE: **MOTOR**  
BHEL TECH SPEC:

REV NO:                      DATE:

PAGE 1 OF 4

SL NO	COMPONENTS	CHARACTERISTICS	CLASS	TYPE OF CHECK	QUANTUM OF CHECK	REFERENCE DOCUMENT	ACCEPTANCE NORMS	FORMAT OF RECORD	*	AGENCY			REMARKS	
										D	P	W		V
<b>1.0 RAW MATERIALS &amp; BOUGHT OUT ITEMS</b>														
1.1	<u>COPPER WIRE</u> Enameled Copper Wire	Overall diameter, elongation, Mandrel winding test, Peel test, springiness, Abrasion test, Cut through test, Heat shock test, Continuity test	Major	Measurement and mechanical & electrical testing	One sample per heat/lot	National & international standard ( IS or IEC) / technical specification/ approved drawing/ datasheet		IR / supplier test certificate	√	2	2	1		
1.2	<u>STEEL SHAFT</u> Straightened Steel bar in black Finish	Dimensions, surface finish, chemical composition	Major	Visual, measurement and chemical testing	One sample per heat/lot			supplier test certificate	√	2	2	1		
1.3		NDT	Major	UT	100%			supplier test certificate	√	2	2	1		
1.4	<u>ALUMINIUM INGOTS</u>	Chemical properties	Major	Chemical testing	One sample per heat/lot			supplier test certificate	√	2	2	1		
<b>2.0 INPROCESS INSPECTION</b>														
2.1	ASSEMBLY	Completeness and correctness of assembly	Major	Visual verification	100%	MO and manufacturer's internal processes	Log book	--	2	2	2			

LEGEND: P: PERFORM, W: WITNESS, V: VERIFICATION. INDICATE 1 FOR BHEL CQS (OR BHEL NOMINATED INSPECTION AGENCY) & 2 FOR VENDOR/SUB VENDOR AS APPROPRIATE AGAINST EACH COMPONENT /CHARACTERISTIC UNDER P, W & V COLUMNS. \* FOR ITEMS MARKED √ (TICK) IN COLUMN 'D', TEST CERTIFICATES SHALL BE SUBMITTED TO BHEL FOR RECORDS.



**TYPICAL MANUFACTURING QUALITY PLAN**

MQP. NO.:

PROJECT ENGINEERING & SYSTEMS  
DIVISION BHEL,  
RC PURAM, HYD-502032

PROJECT:  
PACKAGE: **MOTOR**  
BHEL TECH SPEC:

REV NO:                      DATE:

SL NO	COMPONENTS	CHARACTERISTICS	CLASS	TYPE OF CHECK	QUANTUM OF CHECK	REFERENCE DOCUMENT	ACCEPTANCE NORMS	FORMAT OF RECORD	*	AGENCY			REMARKS
										D	P	W	
<b>3.0</b>	<b>FINAL INSPECTION &amp; TESTING</b>												
3.1	<b>ROUTINE TESTING</b>	Measurement of winding resistance in cold condition	Major	Testing	100%	National & international standard ( IS or IEC ) / technical specification		TC	√	2	1	--	
3.2		SH heater resistance (if applicable)	Major	Testing	100%			TC	√	2	1	--	
3.3		Insulation resistance (before and after HV test)	Major	Testing	100%			TC	√	2	1	--	
3.4		High voltage test at 1.8 KV for 1 minute and space heater HV test	Major	Testing	100%			TC	√	2	1	--	
3.5		Direction of rotation	Major	Testing	100%			TC	√	2	1	--	
3.6		No load test (measurement of NL A, voltage, NL power and NL RPM)	Major	Testing	100%			TC	√	2	1	--	
3.7		Reduced run up voltage test at ( rated volt√3)	Major	Testing	100%100%			TC	√	2	1	--	
3.8		Locked rotor test at full load current	Major	Testing	100%			TC	√	2	1	--	
3.9		Vibration measurement	Major	Testing	100%			TC	√	2	1	--	
3.10		Measurement of noise level	Major	Testing	100%			TC	√	2	1	--	
3.11		120% over speed test	Major	Testing	100%			TC	√	2	1	--	

LEGEND: P: PERFORM, W: WITNESS, V: VERIFICATION. INDICATE 1 FOR BHEL CQS (OR BHEL NOMINATED INSPECTION AGENCY) & 2 FOR VENDOR/SUB VENDOR AS APPROPRIATE AGAINST EACH COMPONENT /CHARACTERISTIC UNDER P, W & V COLUMNS. \* FOR ITEMS MARKED √ (TICK) IN COLUMN 'D', TEST CERTIFICATES SHALL BE SUBMITTED TO BHEL FOR RECORDS.



**TYPICAL MANUFACTURING QUALITY PLAN**

MQP. NO.:

PROJECT ENGINEERING & SYSTEMS  
DIVISION BHEL,  
RC PURAM, HYD-502032

PROJECT:  
PACKAGE: **MOTOR**  
BHEL TECH SPEC:

REV NO:                      DATE:

PAGE 3 OF 4

SL NO	COMPONENTS	CHARACTERISTICS	CLASS	TYPE OF CHECK	QUANTUM OF CHECK	REFERENCE DOCUMENT	ACCEPTANCE NORMS	FORMAT OF RECORD	* D	AGENCY			REMARKS
										P	W	V	
3.12	<b>TYPE TESTS</b>	Measurement of winding resistance in cold condition	Major	Testing	One /rating	National & international standard ( IS or IEC) / technical specification		TC	√	2	--	1	Verification of Identical Type test Report of same Rating
3.13		Temp. rise test at full load ( load point for 100%, 75% & 50% load ( full load, ¾ and ½ load)	Major	Testing	One /rating			TC	√	2	--	1	
3.14		160% momentary overload test	Major	Testing	One /rating			TC	√	2	--	1	
3.15		Locked rotor amp and torque test	Major	Testing	One /rating			TC	√	2	--	1	
3.16		No load test	Major	Testing	One /rating			TC	√	2	--	1	
3.17		Reduced voltage running up test	Major	Testing	One /rating			TC	√	2	--	1	
3.18		Insulation resistance test ( before and after HV test)	Major	Testing	One /rating			TC	√	2	--	1	
3.19		HV test – 1.8 KV for winding and 1.5 KV for space heater	Major	Testing	One /rating			TC	√	2	--	1	
3.20		Vibration test	Major	Testing	One /rating			TC	√	2	--	1	
3.21		120% over speed test	Major	Testing	One /rating			TC	√	2	--	1	

LEGEND: P: PERFORM, W: WITNESS, V: VERIFICATION. INDICATE 1 FOR BHEL CQS (OR BHEL NOMINATED INSPECTION AGENCY) & 2 FOR VENDOR/SUB VENDOR AS APPROPRIATE AGAINST EACH COMPONENT /CHARACTERISTIC UNDER P, W & V COLUMNS. \* FOR ITEMS MARKED ✓ (TICK) IN COLUMN 'D', TEST CERTIFICATES SHALL BE SUBMITTED TO BHEL FOR RECORDS.

SL NO		COMPONENTS	CHARACTERISTICS	CLASS	TYPE OF CHECK	QUANTUM OF CHECK	REFERENCE DOCUMENT	ACCEPTANCE NORMS	FORMAT OF RECORD	*	AGENCY			REMARKS
										D	P	W	V	
<b>4.0</b>		<b>PRESERVATION &amp; PACKING</b>												
			Painting*, (Shade, DFT,) Marking	Major	Visual, DFT	Random	Technical specification/ approved drawing/datasheet		TC	√	2	--	1	
			Packing*	Major	Visual	Random			Packing List	√	2	--	--	

**Notes:-**

- This MQP should be read along with specification ((Latest revisions to be considered as per PO), approved drawings & approved datasheet.
- Specification/drawing/datasheet shall prevail over quality plan for contradiction if any.
- Any project/customer specific requirements which shall be notified have to be fulfilled by the vendor at the time of execution of order.

**Abbreviations:-**

MTC	-	Material Test certificate	COC	-	Certificate of Compliance	DFT	-	Dry Film Thickness
TC	-	Test Certificate	NDE	-	Non Destructive Examination	IR	-	Inspection Report
DFT	-	Dry Film Thickness	IBR	-	Indian Boiler Regulations	IS	-	Indian Standards

LEGEND: P: PERFORM, W: WITNESS, V: VERIFICATION. INDICATE 1 FOR BHEL CQS (OR BHEL NOMINATED INSPECTION AGENCY) & 2 FOR VENDOR/SUB VENDOR AS APPROPRIATE AGAINST EACH COMPONENT /CHARACTERISTIC UNDER P, W & V COLUMNS. \* FOR ITEMS MARKED ✓ (TICK) IN COLUMN 'D', TEST CERTIFICATES SHALL BE SUBMITTED TO BHEL FOR RECORDS.

ESP-001-  
2A Rev.00



**PROJECT ENGINEERING & SYSTEMS DIVISION**

Std. / Doc. Number

Rev. No. 00

**COPYRIGHT AND CONFIDENTIAL**

The information on this document is the property of **BHARAT HEAVY ELECTRICALS LIMITED**,  
It must not be used directly or indirectly in any way detrimental to the interest of the company.

# Annexure-8

## SUB VENDOR LIST

**Revisions:**  
Refer to record of revisions

No.	Description	Rev.	Date

## **Vendor List:**

**Motor:** Siemens, ABB, Bharat Bijlee, Crompton, Kirloskar, Texmo, NGEF, Alstom

### **Signal Cable:**

a) Cord Cable, b) Udey Pyrocable, c) Special Cables & d) Thermo cables.

### **Cable Glands:**

a) Electromeg, b) CCI, c) Dowels, d) Metal Crafts Industries, Rajkot,

### **Cable Lugs:**

a) Phoneix, b) Dowells & c) Hex

### **LT Power Cable & Control Cable:**

Polycab / apar industries / special cables / universal / RPG / KEI,Bhiwadi/ Havells / Skytone / Laser cables / Gems cab /Sbee cables / v-guard industries/ CCI / Cords/ General cable india / TBEA china / New Baofeng china / Far east china / Gupta power ltd.

Note:

Bidder shall follow approved sub vendors list. In case of any specific practical difficulty, bidder is requested to bring out the same with proper reason for not following vendor list. For other items for which sub vendors are not specified, bidder can follow their standard vendors. However, they have to ensure the Proven Track record of the sub vendors and Bidder to take prior approval of BHEL for the same.

ESP-001-  
2A Rev.00



**PROJECT ENGINEERING & SYSTEMS DIVISION**

Std. / Doc. Number

Rev. No. 00

**COPYRIGHT AND CONFIDENTIAL**

The information on this document is the property of **BHARAT HEAVY ELECTRICALS LIMITED**,  
It must not be used directly or indirectly in any way detrimental to the interest of the company.

# Annexure-9

## MASTER DOCUMENT LIST

**Revisions:**

Refer to record of revisions

Rev. No.	Description	By	Date



**MASTER DOCUMENT LIST - Air Blower**

Vendor Name:					PROJECT:											
Vendor Contact Person:					BHEL PO No.		PO date:		PO Dly. Date:							
Vendor contact No.					Supplier's Job No.											
SYSTEM/PACKAGE:		Air Blower				TODAY-DATE	11-Oct-21									
Sl.No	DRG/DOC. NAME	DRG/ DOC NO.	NO. OF SHTS.	CAT	CRITICAL FOR MFG?	REQD.FOR CUSTOMER SUBMISSION?	Plan date of submission	Count of DUE as on Dt.	STATUS	Rev-0			Rev-1			
			NO.	(A / I)	(Y/N)	(Y/N)	dd-mmm-yyyy		" " /PV/PB /PC/AA	SD	AD	APP.CAT	SD	AD	APP.CAT	
10	BILL OF MATERIAL			A	N	N										
11	BILLING BREAKUP			A	N	N										
12	QUALITY ASSURANCE PLAN			A	N	Y										
13	SUB VENDOR LIST			I	N	N										
14	COMMISSIONING SPARES LIST			A	N	N										
15	O&M Spares List			A	N	N										
16	LUBE OIL SCHEDULE			I	N	N										
17	STARTUP PROCEDURE			I	N	N										
18	ERECTION PROCEDURE & Comissioing procedure			I	N	N										
19	INSPECTION/TESTS REPORTS/CERTIFICATE			I	N	N										
20	O& M Manuals(Soft Copies)			A	N	N										
21	O& M Manuals(Hard Copies)** ** hard copy shall be furnished after getting concurrence on soft copy.			I	N	N										
								TOTAL	0			^APP.CAT				
A-Approval Category		PV-Commented and pending with vendor					TOTAL "PV"		0	A1-'Approved						
I-Information Category		PB- Pending with BHEL					TOTAL "PB"		0	A2-'Mfg. Clearance given subject incorporation of comments						
		PC- Pending with Customer					TOTAL "PC"		0	A3-Commented.Revision & resubmission required.						
		AA- Approved					TOTAL "AA"		0	A4- Retained for info.						
		" " - Not yet Due.														
		OD-Overdue					TOTAL "OD"		0							
		" " - Not yet Due.														

Vendor documentation status									
Total No of Docs	Due as on Date	Submitted by vendor as on Dt.	Approved by BHEL as on Dt.	Commented by BHEL as on Dt.	Pending with BHEL/CUSTOMER as on date	%age of Dos Approved	%age of critical Dos Approved	Is Mfg. Clearance given?	Status/ Remarks
(Nos)	(Nos)	(Nos)	(Nos)	(Nos)	(Nos)	% age	% age	(Y/N)/ (If Y ) put Dt.	
0	0	0	0	0	0	#DIV/0!	0.00%	Y	

ESP-001-  
2A Rev.00



**PROJECT ENGINEERING & SYSTEMS DIVISION**

Std. / Doc. Number

Rev. No. 00

**COPYRIGHT AND CONFIDENTIAL**

The information on this document is the property of **BHARAT HEAVY ELECTRICALS LIMITED**,  
It must not be used directly or indirectly in any way detrimental to the interest of the company.

# Annexure-10

## DEVIATION FORMAT

**ANNEXURE-10: DEVIATION FORMAT**

<b>Sl. No.</b>	<b>Section / Part/Subsection</b>	<b>Page No.</b>	<b>Clause No.</b>	<b>Bid Specification Requirement</b>	<b>Bidder's Deviation</b>

**Notes:**

1. Bidder to furnish duly filled format along with SEAL & SIGN along with their offer.
2. All the pre-bid queries (if any) shall be raised before submission of the offer as per pre-bid query format (Annexure- 11).
3. Deviations, which are impractical, and the same were raised during pre-bid stage as per pre-bid query format (Annexure-12), but still purchaser’s reply/clarifications could not be met shall only be raised in this format.
4. If there are no deviations, bidders shall indicate as “No deviation” and submit the same along with their offer.
5. Deviations indicated elsewhere in bidders offer except raised through this format shall not be considered and reviewed during technical evaluation of their offer.

SIGNATURE : \_\_\_\_\_  
 NAME : \_\_\_\_\_  
 DESIGNATION : \_\_\_\_\_  
 COMPANY : \_\_\_\_\_  
 DATE : \_\_\_\_\_

COMPANY SEAL

ESP-001-  
2A Rev.00



**PROJECT ENGINEERING & SYSTEMS DIVISION**

Std. / Doc. Number

Rev. No.

# Annexure-11

## PREBID CLARIFICATION

### **COPYRIGHT AND CONFIDENTIAL**

The information on this document is the property of **BHARAT HEAVY ELECTRICALS LIMITED**,  
it must not be used directly or indirectly in any way detrimental to the interest of the company.

**Revisions:**  
Refer to record of revisions

Prepared by :

Checked by :

Approved by :

**ANNEXURE-11:PRE-BID QUERIES FORMAT**

<b>Sl. No.</b>	<b>Section / Part/Subsection</b>	<b>Page No.</b>	<b>Clause No.</b>	<b>Bid Specification</b>	<b>Bidder's Query</b>	<b>Purchaser's Reply</b>

**Note: During Preparation of Pre-Bid Queries, Complete Tender Specification (along with all Annexures) shall also be referred.**