



Bharat Heavy Electricals Limited

(High Pressure Boiler Plant)

Tiruchirappalli – 620014, TAMIL NADU, INDIA

CAPITAL EQUIPMENT / MATERIALS MANAGEMENT

An ISO 9001
Company

ENQUIRY	Phone: +91 431 257 76 83 Fax : +91 431 252 07 19 Email : ramado@bheltry.co.in Web : www.bhel.com
----------------	---

	Enquiry Number: 2720800012	Enquiry Date: 10.10.2008	Due date for submission of quotation: 17.11.2008
--	---	---	---

You are requested to quote the Enquiry number date and due date in all your correspondences. This is only a request for quotation and not an order

Item	Description	Quantity	Delivery (Item required at BHEL on)
10	5 Ton Gantry Crane as per the technical specification & commercial conditions applicable (to be downloaded from web site www.bhel.com or http://tenders.gov.in)	1 No.	31.08.2009

Note: Offer should be Foreign Bidders: CFR Mumbai Port

Indigenous Vendors:
FOR, BHEL, Stores
Industrial Valves Plant
433, Industrial Complex
Goindwal – 143 423
District: Tarn Taran (Punjab), India

BHEL commercial terms & conditions with Price Bid and Bank Guarantee formats along with technical specifications can be downloaded from BHEL web site <http://www.bhel.com> or from the Government tender website <http://tenders.gov.in> (public sector units > Bharat Heavy Electricals Limited page) under Enquiry reference “2720800012”.

Tenders should reach us before 14:00 hours on the due date Tenders will be opened at 14:30 hours on the due date Tenders would be opened in presence of the tenderers who have submitted their offers and who may like to be present	Yours faithfully, For BHARAT HEAVY ELECTRICALS LIMITED Sr.Manager / MM / Capital Equipment
--	---

PART A

SECTION – I: QUALIFYING CRITERIA

The BIDDER (OEM) has to compulsorily meet the following requirements to get qualified for consideration of the technical offer for the supply of GANTRY CRANE

S. No	PARTICULARS	VENDOR'S RESPONSE
1.0	<p>Only those Vendors (OEMs), who have supplied and commissioned at least ONE 5 Ton or higher capacity GANTRY CRANE of duty class-3, with a span of 10 Meters or more and also who have supplied VVVF drive for any crane in the past and such crane should be working satisfactorily for a minimum period of one year after commissioning, as on the date of opening of this Tender are eligible to quote.</p> <p><i>(However, if such crane is already supplied to BHEL, then that crane should be working satisfactorily for a minimum period of six months after commissioning, as on the date of opening of this Tender.)</i></p>	
2.0	The bidding FIRM should have 'in-house' or 'self-owned' facility for TESTING at 125 % of the rated capacity.	
3.0	The vendor should have minimum 10 years experience in the field of design and fabrication of GANTRY cranes.	
4.0	Along with the Technical offer, the Vendor should enclose One Performance certificate from the customer regarding satisfactory performance of the equipment supplied to them. The equipment for which performance certificate is produced should meet the requirements stipulated in S.No 1 above. For obtaining the Performance certificate from the customer, a suggestive format is provided in SECTION – IV .	
5.0	BHEL reserves the right to verify the information provided by vendor. In case the information provided by vendor is found to be false/ incorrect, the offer shall be rejected.	

SECTION – II

The Bidder / Vendor is requested to provide the following information.

S. No.	PARTICULARS	VENDOR'S RESPONSE
6.0	The Vendor shall specify the number of Years of experience (for the firm), in the field of design, manufacture, supply and Erection & commissioning of cranes	
7.0	Number of GANTRY Cranes supplied and commissioned till date	
8.0	Number of GANTRY Cranes supplied and commissioned till date in the QUOTED MODEL.	
9.0	Details on SERVICE-AFTER-SALES Set-Up in India including the Addresses of Agents / Service Centers in India / Asia.	
10.0	Any Additional Data to supplement the manufacturing capability of the BIDDER for the subject equipment.	

SECTION – III

Bidder / Vendor to note:

S.No.	REQUIREMENTS	VENDOR'S RESPONSE
11.0	The BIDDER / VENDOR shall submit the offer in TWO PARTS. 1. Technical offer (with PART A & PART B) & Commercial offer. 2. Price Bid.	
12.0	The Offer shall contain a comparative statement of Technical Specifications demanded by BHEL and Offer Details submitted by the Bidder , against each clause. A just 'CONFIRMED' or 'COMPLIED' or 'YES' or 'NO-DEVIATION' or similar words in the technical comparative statement may lead to disqualification of the Technical Offer.	
13.0	The Technical Offer shall be supported by Product Catalogue and Data Sheets in ORIGINAL and complete technical details of 'Bought-Out-Items' with copies of Product Catalogue and Selection Criteria	
14.0	The Commercial Offer (given with the Technical Offer) shall contain the Scope of Supply and the Un-Priced Part of the Price-Bid, for confirmation	

SECTION – IV

The Performance certificate should be produced on Customers Letter head.

PERFORMANCE CERTIFICATE

1	Supplier of the Equipment	
2	Make & Model of the Equipment	
3	Month & Year of Commissioning	
4	Application	
5	a. Crane Type	
	b. Crane Capacity (Metric Tons)	
	c. Crane span	
	d. Duty class	
	e. Mechanism Group	
6	Performance of the Equipment (Tick whichever is applicable)	Best in the market
		Satisfactory
		Good
		Average
		Not Satisfactory
7	Any other remarks	
Signature & Seal of the Authority Issuing the Performance Certificate		
Date:		

PART B

Technical Specification For 5Ton Capacity, 15.0 Mtr Span, 5 Mtr Lift, Double Girder OUTDOOR GANTRY CRANE (GOLIATH)

S.No.	PARTICULARS	BHEL SPECIFICATIONS	VENDOR's TECHNICAL OFFER (With Complete Details)
1.0	APPLICATION	a. The subject crane is meant for the purpose of handling (within the lifting capacity of the crane) valve components, in a closed stores yard. b. The crane will be put to use for 365 Days' continuous duty with CT, LT and Hoist movements, which may occur simultaneously (within the operating parameters specified under Clause Nos. – 3.1, 3.4 and 3.5). c. The environment will be dust prone, humid and ambient temperature going up to 45 ° C.	
2.0	SCOPE OF SUPPLY	a. Crane as per the Tender Specifications given under this PART-B. b. Assembly and Testing before Dispatch c. Supply in major Sub-Assemblies d. Commissioning and Performance Prove-Out at BHEL Works e. Performance Guarantee for 12 months, from the date of commissioning.	
3.0	TECHNICAL SPECIFICATIONS		
3.1	CAPACITY	Lifting Capacity	
3.1.1	Hoist	5 Metric Tons	
3.2	SPAN	Wheel Center to Wheel Center Dimensions	
3.2.1	Long Travel (LT)	15,000 mm	
3.2.2	Cross Travel (CT)	1,600 mm	
3.3	Height of Lift	5,000 mm	

S.No.	PARTICULARS	BHEL SPECIFICATIONS	VENDOR'S TECHNICAL OFFER (With Complete Details)
3.4	DUTY CYCLE	Related to Drive Motor & Mechanisms	
3.4.1	Hoist	40 % E D	
3.4.2	Long Travel	40 % E D	
3.4.3	Cross Travel	40 % E D	
3.5	SPEED	Operating / Working Speed [Maximum]	
3.5.1	Hoist	5 mtrs./minute.	
3.5.2	Cross Travel (CT)	15 mtrs./minute.	
3.5.3	Long Travel (LT)	30.0 mtrs./minute.	
3.6	MOTOR RATINGS - MIN.	Electric Drive Motor Ratings All motors shall be of slip ring induction type.	
3.6.1	Hoist	7.5 kW, 6 Pole, 40% CDF, S4 duty, 300 St /Hr.	
3.6.2	Cross Travel (CT)	2.2 kW; 6 Pole, 40% CDF, S4 duty, 300 St./Hr.	
3.6.3	Long Travel (LT)	2 x 3.7 kW; 6 Pole, 40% CDF, S4 duty, 300 St./Hr.	
3.7	GEAR BOX	Gear Box Size	
3.7.1	Hoist	HR 525	
3.7.2	Cross Travel (CT)	VR 275	
3.7.3	Long Travel (LT)	VR 450 – 2 nos	
3.8	ACCELERATION		
3.8.1	Cross Travel (CT)	300 mm / sec.sq.	
3.8.2	Long Travel (LT)	300 mm / sec. sq.	
3.9	HOIST ROPE DETAILS	Size and Number of Falls of Rope	
3.9.1	Hoist	Dia. 12 mm; Falls - 4	
3.10	CONTROL	Push Button Operation and Radio Remote Control	
3.11	Type of Control	Master control for all motions.	
3.12	Control Voltage	110 V AC	
3.13	Input Power Supply	415 ± 10% Volts, 50 ± 3% Hz, 3 Phase- AC SUPPLY	
3.14	Duty Class	Class – 3 [Out door Service]	
3.15	Mechanism Group	M 6	

SAN

PSG

GCS

AVC

NRM

	Classification		
S.No.	PARTICULARS	BHEL SPECIFICATIONS	VENDOR'S TECHNICAL OFFER (With Complete Details)
3.16	DESIGN STANDARD	IS – 807 & 3177	
3.17	Runway Rail Size		
3.17.1	Cross Travel (CT)	ISR 60 Lbs./Yard - Rail by vendor	
3.17.2	Long Travel (LT)	ISR 90 Lbs./Yard (For reference only) - Rail by BHEL	
3.18	Wheel Size		
3.18.1	Cross Travel (CT)	Dia. 250 mm	
3.18.2	Long Travel (LT)	Dia. 400 mm	
3.19	Brake Drum Size	Brake Drum Sizes	
3.19.1	Hoist	Dia. 200 mm	
3.19.2	Cross Travel (CT)	Dia. 160 mm	
3.19.3	Long Travel (LT)	Dia. 200 mm	
4.0	MAIN FEATURES	Crane Operational Features	
4.1	Control System	Master control for all motions	
4.2	Crane Operation	Cabin with Push Button control and Radio Remote Control.	
4.3	Operator Cabin	Control Cabin fitted on one end carriage	
5.0	STRUCTURAL FABRICATION	Crane Structure Constructional Details	
5.1	Bridge / Leg	Box type Construction	
5.1.1	LT & CT wheel carriages	Plate formed box type only.	
5.2	Raw Material	Steel plates used shall have test certificates. Test Certificates to be produced for BHEL verification and form part of the documentation.	
5.3	Welded Joints for bridge / leg fabrication		
5.3.1	Number of Joints allowed	Only two weld joint is permitted in flange and web plates of bridge girder. Splice joint is not permitted.	

SAN

PSG

GCS

AVC

NRM

S.No.	PARTICULARS	BHEL SPECIFICATIONS	VENDOR'S TECHNICAL OFFER (With Complete Details)
5.3.2	Welding Electrodes	a. For all Horizontal Welding E 7018 Electrode only should be used. b. For all Vertical Welding E 7048 Electrode only should be used.	
5.3.3	Welded Joint Testing	All Butt Welded Joints (both compression / tension and flanges / web joints) shall be subjected to 100% X-Ray Testing and X-Ray Films to be produced for BHEL verification and form part of the documentation.	
5.4	Leg connection	Leg to bridge connection shall be designed for double shear with fit bolts as per IS - 3640	
5.5	Platform on Girders	The Platforms provided on both the Girders shall be fixed through BOLTED JOINTS with fit bolt as per IS-3640 only.	
5.6	Wheel Assembly	The Wheel Assembly coming for Cross Travel (CT) & Long Travel (LT) shall be of LIVE AXLE SYSTEM with L-Type Bearings. [Refer to BHEL Drawing No. 3-M-02R-0011993. Drawing is enclosed and given as ANNEXURE -1]. Bogie type assembly shall be for LT wheels.	
5.7	Heat Treatment & NDT Examination	The Trolleys shall be stress relieved after welding and subject to NDT examinations. All welding shall be tested by NDT means [MPI, LPI & RT] after Stress Relieving operation.	
5.8	Machining Operation	All mechanical mating surfaces and wheel seating areas are to be machined to the required finish.	
5.9	Surface Cleaning	Both the Girders and the Trolleys are to be shot blasted or chemically treated for surface cleaning, after completion of all operations but prior to painting.	

SAN

PSG

GCS

AVC

NRM

S.No.	PARTICULARS	BHEL SPECIFICATIONS	VENDOR'S TECHNICAL OFFER (With Complete Details)
5.10	Painting	The crane parts are to be painted as follows: a. One coat primer. b. Two coats of Enamel Paint –Color- Golden yellow.	
6.0	MECHANICAL ELEMENTS		
6.1	Gears	Gears in all the Stages shall be helical in design and to be of machined, lapped and hardened.	
6.2	Gear Box Casing	Shall be of fabricated type and stress relived by thermal heat-treatment process, prior to machining.	
6.3	Rope Drum	Shall be of fabricated type and stress relieved. The circumferential weld joints shall be tested by 100 % X-Ray for quality assurance.	
6.4	Type of Coupling	Only GEARED COUPLING to be used a. Between Electric Motor and Gear Box b. Between Gear Box and Rope Drum c. Between Gear Box and Trolley Wheels	
6.5	Wheels	The Wheels shall be of Forged and Wheel Tread hardened to 300/350 BHN. Wheels shall be fitted with L-Type Bearings	
6.6	Mechanical Joints	Fit Bolts as per IS 3640 for all joints coming in main members and platform with reamed holes	
6.7	Pulley Dimension	Rope Pulley diameter shall be 23 times that of Rope diameter	
6.8	Hook	Hook latch shall be provided for hook	
7.0	ELECTRICAL ELEMENTS		
7.1	Operational Controls	The Crane shall be provided with the following controls: a. Push button Station and b. Radio Remote Control - 2 step Push Button Type	
7.2	Control Voltage	110 V AC	

SAN

PSG

GCS

AVC

NRM

S.No.	PARTICULARS	BHEL SPECIFICATIONS	VENDOR'S TECHNICAL OFFER (With Complete Details)
7.3	Type of Brakes	a. Hoist – Thruster b. Cross Travel - Thruster Brake d. Long Travel - Thruster Brake	
7.4	Protection	All Panels, Limit-Switches and Motors shall have IP 54 protection.	
7.5	Electric Motors	All Electric Motors shall be as per IS-325 and IS-1231 and also suitable for 300 starts per hour.	
7.6	Electric Contactors	All Panels shall have SIEMENS or L&T Contactors and shall be suitable for AC3 Duty Class.	
7.7	Contactors Rating	The rating of all Contactors shall be at least 50% higher than the respective electric motor full load current, at the specified duty cycle.	
7.8	Resistance	Shall be stainless steel grid type of 10Min. rating. (suitable ohmic value)	
7.9	Long Travel Motion	Dual Drive Mechanism shall be provided for Long Travel Motion.	
7.10	Illumination	a. Two numbers of 500 Watts Halogen Lamps shall be provided under the Bridge b. All Electric Panels shall be provided with suitable illumination for visibility and troubleshooting.	
7.11	Controller Steps	A 4-Step Control has to be provided for a. Main Hoist b. Long Travel c. Cross Travel	
7.12	Cables	All cables shall be of flexible copper type only and for CT festoon system with roller trolley arrangement or with cable drag chain arrangement.	
7.13	Hoist Limit	Hoist shall be provided with both rotary and counter weight limits.	

SAN

PSG

GCS

AVC

NRM

S.No.	PARTICULARS	BHEL SPECIFICATIONS	VENDOR'S TECHNICAL OFFER (With Complete Details)
7.14	Control Cabin	Electric Light, Fan, Warning Bell and Emergency Stop Push Button shall be provided in the control cabin.	.
8.0	SELECTION of COMPONENTS	The makes of Components or Bought-Out-Items shall be strictly as per the list given below.	
8.1	Hoist Hooks	HERMAN MOHTTA / HERCULES / SILPA UDYOG / SMRITI FORGINGS / KARACHIWALA	
8.2	Wire Rope	USHA MARTIN / FORT WILLIAM / RA WIRE ROPE	
8.3	Electric Motors	BHARAT BIJLEE / SIEMENS / KEC / MARATHON	
8.4	Thruster Brake Unit	ELECTROMAG / SPEED-O-CONTROL / OMEGA / TECHNICAL SYSTEMS	
8.5	Radio Remote Control	ITOWA /TELECRANE make (Model-F24-10D) Micro – Processor type.	
8.6	Limit Switch (Gravity Type)	SIEMENS / INDUSTRIAL SYNDICATE / BCH / SKC / SOC	
8.7	Contactors	SIEMENS / L&T make	
8.8	Over-Load-Relay	SIEMENS / L&T (THERMAL TYPE)	
8.9	HRC Fuses	GEC / L&T /SIEMENS	
8.10	Rotary limit switch	SIEMENS / OMEGA / SOC / INDUSTRIAL SYNDICATE	
8.11	Switch fuse unit	SIEMENS / GEC / L&T	
8.12	Molded case C.B	SIEMENS / L&T / LEGREND	
8.13	ON Delay Timer	Electronic Type	
8.14	Push - Buttons	SIEMENS / L&T	
8.15	Connectors	Only ELMAX make	
8.16	Couplings	WMI / FENNER / ALFEX	
8.17	Bearings	SKF / NBC / ZKL	
8.18	Cables	Reputed Makes & ISI Approved	
8.19	Bridge Light Fittings	PHILIPS / GE / CROMPTON	

SAN

PSG

GCS

AVC

NRM

S.No.	PARTICULARS	BHEL SPECIFICATIONS	VENDOR'S TECHNICAL OFFER (With Complete Details)
8.20	Resistance box	SOC / OMEGA / ELECTROMAG / TECHNICAL SYSTEMS	
8.21	Other Elements	Vendor to specify items and makes	
9.0	DOCUMENTS / DETAILS for APPROVAL	The following documents and details are to be submitted for BHEL Approval, prior to taking up the manufacture of the crane.	
9.1	Drawings and Documents	<ul style="list-style-type: none"> a. GA Drawing of the Crane. b. GA Drawing of Crab with Trolley c. GA Drawing of Individual Mechanisms. d. Drawings of Bridge, End-Carriage, legs and their connection. e. Sub-Assembly Drawing for Wheels, Hook Blocks, Gear Boxes & Hoist Drums. f. Calculations for Selection of Electric Motors, Gear Reducers, Brakes, Couplings, etc. g. Calculations for Bridge Girder, Crab, h. End - Carriage and their connections. i. Wiring Diagram with Logic Circuits. j. Cable Selection based on Current Rating and schedule of cables. 	
9.2	Technical Details	<ul style="list-style-type: none"> a. Total Weight of the Crane including all Electrical Equipment b. Total Weight of Trolley including all Electrical Equipment c. Weight of each Bridge assembled and ready for erection with and without Mechanical and Electrical Equipment. d. Weight of each End - Carriage assembled and ready for erection e. Total Weight of Structural, Mechanical and Electrical Equipment are indicated separately also f. Weight of Operator's Cabin together with all Equipment mounted in it. 	
10.0	INSPECTION	The following Schedule of Stage Inspections is to be strictly adhered to, prior to dispatch from the Supplier's Works	

SAN

PSG

GCS

AVC

NRM

S.No.	PARTICULARS	BHEL SPECIFICATIONS	VENDOR'S TECHNICAL OFFER (With Complete Details)
10.1	STAGE – I	a. Verification of Test Certificate for Raw Materials used for Girders, End-Carriages, Trolleys, Gear Box Casings, etc. b. Verification of X-Ray Report of Butt-Joints coming in the Girders and Random Testing on the Welds by physical examination. c. Box Girder setting before closing of the Bottom Flanges – for inspecting the quality of welding and presence of waviness d. Trolley Frame Fabrication before setting the Mechanisms e. End – Carriage and legs Fabrication	
10.2	STAGE – II	a. Inspection of Bridges and End – Carriages with Wheel Assembly and Alignment checking. b. Verification of Span & Diagonal Dimensions, Checking of Wheel Alignment, Mechanical Assemblies and Total Alignment. c. Free running of the all the Mechanisms.	
10.3	STAGE – III [Final Inspection]	a. Measurement of CAMBER in the Bridges. b. Full / Rated Load Test and Deflection Test. c. Deflection and Permanent Set Measurement. d. 25% OVER-LOAD Lifting Ability Check.	
11.0	CRANE ERECTION & COMMISSIONING	Complete Erection and Commissioning of the Crane and its system, Performance Prove –Out for the Crane's Capacity and Smooth Functioning of the Crane (at BHEL Works) shall be the RESPONSIBILITY of the supplier.	

SAN

PSG

GCS

AVC

NRM

S.No.	PARTICULARS	BHEL SPECIFICATIONS	VENDOR'S TECHNICAL OFFER (With Complete Details)
12.0	O & M MANUALS	Each Crane shall be provided with THREE Copies of Erection, Operation & Maintenance Manual hard copy as well as soft copy in CD, containing the following technical details	
12.1	Drawings & Details	a. Crane GA Drawing b. Crab Assembly Drawing c. Total Crane Wiring Schematics d. Detailed Wiring Diagrams for Sub-Systems / Panels e. VVVF Drive's Logic Circuits f. Wheel Assembly Drawings g. Bottom Block Assembly Drawing h. Gear Box Assembly Drawings i. Coupling Drawing and Details j. Specifications/Ratings of All Bought-Out-Items k. Trouble Shooting Chart for Main and all Sub-Systems	
13.0	PERFORMANCE GUARANTEE	The Performance of the Total Crane and the Components / Sub-Assemblies / Bought-Out-Items shall be guaranteed for a minimum period of twelve months from the date of performance acceptance at BHEL Works.	

THIS DRAWING IS OUR SOLE PROPERTY AND SHOULD NOT BE USED IN ANY FORM FOR ANY PURPOSE WITHOUT THE WRITTEN PERMISSION OF BHARAT HEAVY ELECTRICALS LIMITED, TRICHIRAPPALLI - 620 014.

ALL DIMENSIONS ARE IN MM

SL. No.	W.D. (WHEEL DIA) IN MM	RAIL SIZE	A	B	D	E	F	ØG	H	ØJ	K	L	Ød	M (KEY)	N	P	Q	S	R	COUPLING No.	SKF BRG No. & BRG. SIZE	TOTAL WEIGHT IN Kg. FOR DRIVE & IDLE
16	800/850	CR-100 CR-120	190	450	80	210	150	152	140	130	212	255	32	32x18x130	687	588	20	150	80	107	22330 150x320x108	870.00 845.00
15		CR-80	168	420	80	180	110	152	125	110	212	255	32	28x16x115	687	588	20	150	80	106	22330 150x320x108	796.00 775.00
14		CR-100 CR-120	190	450	80	210	150	152	140	130	212	255	32	32x18x130	642	588	20	150	80	107	22330 150x320x108	808.00 784.00
13	710/750	CR-100 CR-120	180	420	71	210	150	132	125	110	180	224	32	28x16x115	607	517	20	130	80	106	22326 130x280x93	728.50 711.50
12		CR-80	180	400	71	180	110	132	125	110	180	224	32	28x16x115	607	517	20	130	80	106	22326 130x280x93	653.00 636.00
11	630/680	CR-80/CR-100 & CR-120	180	420	71	210	150	132	125	110	180	224	32	28x16x115	567	517	20	130	80	106	22326 130x280x93	629.00 611.50
10		90-105 Lbs/Yd CR-80	150	365	60	180	105	111	110	90	160	190	26	25x14x100	547	462	20	120	60	105	22322 110x240x80	448.00 434.50
9		CR-80 CR-100	160	375	60	180	125	111	110	90	160	190	26	22x14x100	482	462	20	120	60	105	22322 110x240x80	253.00 245.50
8	500/550	CR-80	150	360	50	180	125	91	105	80	125	160	26	22x14x90	445	395	20	100	50	104	22318 90x190x64	389.00 378.00
7		60/75/90 & 105 Lbs/Yd	150	360	50	180	105	91	105	80	125	160	26	22x14x90	445	395	20	100	50	104	22318 90x190x64	301.00 294.00
6	400/450	CR-80 CR-100	150	360	50	180	125	91	105	80	125	160	26	22x14x90	395	395	20	100	50	104	22318 90x190x64	253.00 245.50
5		90 Lbs/Yd 105 Lbs/Yd	145	315	40	180	105	76	85	70	112	140	22	20x12x75	375	345	16	90	50	103	22315 75x160x55	197.00 192.00
4	320/370	75 / 90 & 105 Lbs/Yd CR-80	145	315	40	180	105	76	85	70	112	140	22	20x12x75	345	345	16	90	50	103	22315 75x160x55	162.00 157.00
3		50 SQ.BAR 60 Lbs/Yd 75 Lbs/Yd	112.5	260	40	125	85	61	65	55	85	112	17	16x10x55	312	287	16	80	50	102	22312 60x130x46	118.50 118.00
2	250/280	50 SQ.BAR 60 / 90 & 105 Lbs/Yd	105	250	32	125	85	61	65	55	76	100	17	16x10x55	254	249	12	60	40	102	22212 60x110x28	66.00 63.00
1	200/230	50 Lbs/Yd 50 SQ.BAR 60 Lbs/Yd	95	220	32	100	67	46	55	40	71	95	17	12x8x45	239	232	12	65	40	101	22309 45x100x36	51.00 50.00

DIMENSIONS

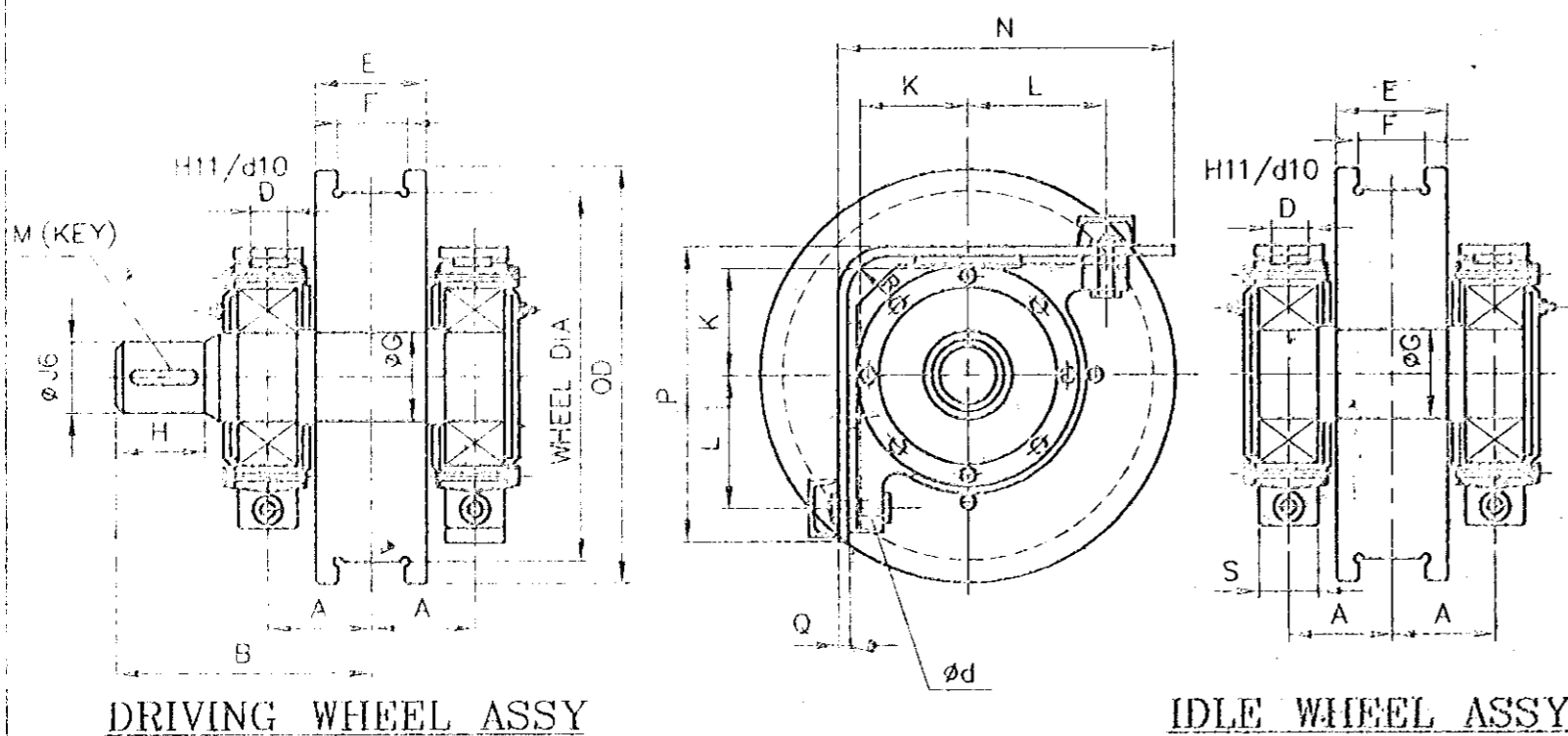

MATERIAL :- SHAFT - 45CB/IS:4283.
WHEEL - 55CB/IS:5517.
FORGED.
THREAD PORTION WHEEL HARDNESS 300 TO 350 (BHN)

No of Pieces	DESCRIPTION	MATERIAL	STANDARD	NET.WT.IN KGS.	DRAWING No.	ITEM No.
	REFERENCE		COMPONENT CODE: 29	EQUIPMENT CODE: 00		
SCALE	DRAWN	CHECKED	APPROVED	DATE	ALTERATIONS	DCN. REF
				20-10-2000		
MACHINE: CRANE WHEEL ASSY				TYPE: GENERAL		
TITLE: STANDARD CRANE WHEEL ASSY				DRAWING No. 3-M-02R-11993		REV.
No of Sheets				Sheet No		