



An ISO 9001
Company

Bharat Heavy Electricals Limited

(High Pressure Boiler Plant)

Tiruchirappalli – 620014, TAMIL NADU, INDIA

CAPITAL EQUIPMENT / MATERIALS MANAGEMENT

ENQUIRY	Phone: +91 431 257 79 38 Fax : +91 431 252 07 19 Email : tvenkat@bheltry.co.in Web : www.bhel.com
NOTICE INVITING TENDER	

TWO PART BID	Enquiry Number:	Enquiry Date:	Due date for submission of quotation:
Tender to be submitted in two Parts	2620900191	15.09.2009	27.10.2009

You are requested to quote the Enquiry number date and due date in all your correspondence. This is only a request for quotation and not an order.

Please note that under any circumstances both **delayed offer** and **late offers** will not be considered. Hence vendors are requested to ensure that the offer is reaching physically our office before 14.00 hrs on the Date of **tender opening**.

Item	Description	Quantity
10	10 Ton EOT Crane - Span 28.65 M & Lift 9 M as per the technical specification & commercial conditions applicable (to be downloaded from web site www.bhel.com or http://tenders.gov.in)	7 Nos.

Important points to be taken care during submission of offer

1. **Delivery required 10 months from the date of purchase order.**
2. **Grace period of 2 months beyond the above delivery period will be considered.**
3. **Checklist to be filled and enclosed along with the offer failing which, the offer will not be considered for evaluation.**

BHEL's General guidelines / instructions (refer MM/CE/GT/001) including bank guarantee formats and list of consortium banks, commercial terms check-list can be downloaded from BHEL web site <http://www.bhel.com> or from the Government tender website <http://tenders.gov.in> (public sector units > Bharat Heavy Electricals Limited page) under Enquiry reference "2620900191".

Tenders should reach us before 14:00 hours on the due date Tenders will be opened at 14:30 hours on the due date Tenders would be opened in presence of the tenderers who have submitted their offers and who may like to be present	Yours faithfully, For BHARAT HEAVY ELECTRICALS LIMITED Manager / Capital Equipment / MM
--	---

PART A**SECTION-I: -QUALIFING CRITERIA**

The BIDDER/VENDOR (OEM) has to compulsorily meet the following requirements to get qualified for consideration of the technical offer for the SUPPLY OF EOT CRANE

S. No.	PARTICULARS	VENDOR'S RESPONSE
1.0	<p>Only those Bidder/vendor (OEM), who have supplied and commissioned at least ONE 10Ton capacity EOT crane class-3 with minimum span of 28 Mtr or higher and should have supplied frequency converter drive for similar capacity crane in the past five years and such crane is presently working satisfactorily for more than one year after commissioning (on the date of opening of Tender), should quote.</p> <p>However, if such crane has been supplied to BHEL, then it should be presently working satisfactorily for more than six months after its commissioning and acceptance (on the date of opening of Tender) in BHEL.</p> <p>Performance certificate from the customers (minimum 2) regarding satisfactory performance of machine supplied to them in attached format should be enclosed along with technical offer.</p>	
2.0	<p>BHEL reserves the right to verify the information provided by vendor. In case the information provided by vendor is found to be false/ incorrect, the offer shall be rejected.</p>	
3.0	<p>The bidding FIRM should have 'in-house' or 'self-owned' facility for FABRICATION and TESTING at 125 % of the rated capacity</p>	
4.0	<p>The vendor should have minimum 10 years experience in design, fabrication and supply of EOT cranes.</p>	
5.0	<p>DELIVERY - The bidder shall quote the best possible delivery. However the delivery shall not exceed 10 months with an additional grace period of 2 months. The additional grace period will attract a penalty which is explained in the commercial terms of the enquiry. The delivery period shall be reckoned from date of purchase order to despatch from the vendor works.</p>	

SECTION – II

The vendors are requested to provide the following details

S. No.	PARTICULARS	VENDOR'S RESPONSE
6.0	Number of Years of Experience of the BIDDER/ VENDOR (OEM) in the field of design, manufacture, supply, erection & commissioning of cranes	
7.0	Number of cranes supplied, installed and commissioned till date	
8.0	Number of cranes supplied, installed and commissioned till date in the QUOTED MODEL	
9.0	Number of cranes supplied, installed and commissioned till date for the following category of CUSTOMERS a) Power Utility Boiler Manufacturer b) Equipment Supplier for Process Industries [Heavy Engineering Companies] c) Research Establishments	
10.0	Details on SERVICE-AFTER-SALES Set-Up in India including the Addresses of Agents / Service Centre in India and Asia	
11.0	Any Additional Data to supplement the manufacturing capability of the BIDDER for the subject equipment.	

SECTION – III

Bidder / Vendor (OEM) to note the following

S.No.	REQUIREMENTS	VENDOR'S RESPONSE
12.0	The BIDDER / VENDOR shall submit the offer in TWO PARTS - Technical [with PART A & PART B] & Commercial and Price Bid.	
13.0	The Offer shall contain a comparative statement of Technical Specifications given by BHEL and the Offer Details submitted by the Bidder, against each clause. Where details are required, a mere 'CONFIRMED' or 'COMPLIES' or 'YES' or 'NO-DEVIATION' or similar words in the technical comparative statement may lead to disqualification of the Technical Offer.	
14.0	The Technical Offer shall be supported by Product Catalogue and Data Sheets in ORIGINAL and complete technical details of 'Bought-Out-Items' with copies of Product Catalogue and Selection Criteria	
15.0	The Commercial Offer (given with the Technical Offer) shall contain the Scope of Supply and the Un-Priced Part of the Price-Bid, for confirmation	
16.0	BIDDER has to indicate the Country of Origin for the supply of equipment.	

PERFORMANCE CERTIFICATE

(On Customer's Letter Head)

1. Supplier of the Equipment :

2. Make & Model of the Equipment :

3. Month & Year of Commissioning :

4. Application :

5.
 - a) Crane Type:

 - b) Crane Capacity (Metric Tonnes):

 - c) Crane span :

 - d) Mechanism class :

6. Performance of the Equipment : Satisfactory /
(Strike off whichever is not applicable) Good /
Average /
Not Satisfactory

7. Any other remarks:

Date:

Signature & Seal of the Authority
Issuing the Performance Certificate

PART B.**TECHNICAL SPECIFICATIONS FOR 10T ELECTRICALLY OPERATED OVER-HEAD TRAVELLING [E O T] CRANE WITH DOUBLE GIRDERS**

S.No.	PARTICULARS	BHEL SPECIFICATIONS	VENDOR'S TECHNICAL OFFER (With Complete Details)
1.0.0	APPLICATION	a. The subject crane is meant for the purpose of handling small to large (within the lifting capacity of the crane) components, in a heavy and large steel fabrication shopfloor. b. The crane will be put to use for continuous duty with CT, LT and Hoist movements, which may occur simultaneously (within the operating parameters specified under Clause Nos. – 3.1.0, 3.4.0 and 3.5.0). c. The shop floor environment will be dust prone, humid, welding fume filled and ambient temperature going up to 45 ° C, due to pre-heating of jobs.	
2.0.0	SCOPE OF SUPPLY	a. Design as per Tender Specifications b. Detailed Design, Manufacture, Assembly and Testing before Despatch c. Supply in Modules / Sub-Assemblies d. Commissioning and Performance Prove-Out at BHEL Works e. Performance Guarantee for 12 months, from the date of commissioning.	
3.0.0	TECHNICAL SPECIFICATIONS		
3.1.0	CAPACITY	Lifting Capacity	
3.1.1	Main Hoist	10 Metric Tonnes	

S.No.	PARTICULARS	BHEL SPECIFICATIONS	VENDOR's TECHNICAL OFFER (With Complete Details)
3.2.0	SPAN	Wheel Centre to Wheel Centre Dimensions (Rail Centre to Rail Centre)	
3.2.1	Long Travel (LT)	28,650 mm	
3.2.2	Cross Travel (CT)	2,500 mm	
3.3.0	Height of Lift	9,000 mm [Effective Height of Lift for both the HOISTS]	
3.4.0	DUTY CYCLE	Related to Drive Motor & Mechanisms	
3.4.1	Hoists	40 % CDF	
3.4.2	Long Travel	40 % CDF	
3.4.1	Cross Travel	40 % CDF	
3.5.0	SPEED	Operating / Working Speed [Maximum]	
3.5.1	Main Hoist	15.0 mtrs./minute.	
3.5.2	Cross Travel (CT)	30.0 mtrs./minute.	
3.5.3	Long Travel (LT)	70.0 mtrs./minute.	
3.6.0	MOTOR RATINGS	Electric Motor Ratings & Frame Sizes shall be as per IS-325 and IS-1231 and also suitable for 300 starts per hour.	
3.6.1	Main Hoist	Min.30.4 kW ; Frame Size – VD250 M / 6 Pole	
3.6.2	Cross Travel (CT)	Min. 4.9kW ; Frame Size – VD132 M / 6 Pole	
3.6.3	Long Travel (LT)	Min. 2 x 12.5 kW ; Frame Size – VD200 L / 6 Pole	
3.7.0	GEAR BOX	Gear Box Size	
3.7.1	Main Hoist	HR 650	
3.7.3	Cross Travel (CT)	VR 320	
3.7.4	Long Travel (LT)	HR 350	
3.8.0	ACCELERATION		
3.8.1	Cross Travel (CT)	300 mm / sec.sq.	
3.8.2	Long Travel (LT)	300 mm / sec. sq.	
3.9.0	HOIST ROPE DETAILS	Size and Number of Falls of Rope	

S.No.	PARTICULARS	BHEL SPECIFICATIONS	VENDOR'S TECHNICAL OFFER (With Complete Details)
3.9.1	Main Hoist	Dia. 18 mm ; Falls - 4	
3.10.0	CONTROL	Cabin Operation and Remote Control	
3.11.0	Type of Control	Master Control and Radio Remote Control	
3.12.0	Control Voltage	110 V AC	
3.13.0	Input Power Supply	415 Volts with $\pm 10\%$ fluctuation , 50 Hz with $\pm 3\%$ fluctuation, 3 Phase- AC	
3.14.0	Duty Class	Class – 3 [Indoor Service]	
3.15.0	Mechanism Group Classification	M 6	
3.16.0	DESIGN STANDARD	IS – 807 & 3177 / 2006	
3.17.0	Runway Rail Size		
3.17.1	Cross Travel (CT)	ISR 60 Lbs./Yard	
3.17.2	Long Travel (LT)	C R 80	
3.18.0	Wheel Size		
3.18.1	Cross Travel (CT)	Dia. 250 mm	
3.18.2	Long Travel (LT)	Dia. 500 mm	
3.19.0	Brake Drum Size	Hoist Brake Drum Sizes	
3.19.1	Main Hoist	Dia. 300 mm	
3.19.3	Cross Travel (CT)	Dia. 160 mm	
3.19.4	Long Travel (LT)	Dia. 200 mm	
4.0.0	MAIN FEATURES	Crane Operational Features	
4.1.0	Control System	Frequency Converter type for all motions	
4.2.0	Remote Control	Radio Remote Control for all motions	
4.3.0	End Clearance	End Clearances to be fixed to suit the workshop building clearances [Refer to Drawing No. M&S: PD: 07:113/01 – Drawing enclosed with the tender as ANNEXURE-1 .	Bidder to give the Clearance Dimensions with the Technical Offer, as per the style in the drawing mentioned.
4.4.0	Crane Operation	Through Cabin Control and Radio Remote Control with option for control selection	

S.No.	PARTICULARS	BHEL SPECIFICATIONS	VENDOR's TECHNICAL OFFER (With Complete Details)
5.0.0	STRUCTURAL FABRICATION	Crane Structure Constructional Details	
5.1.0	Bridge / Girder	Box type Construction for Girders	
5.2.0	Raw Material	Only steel plates, tested and certified for quality by reputed inspection authorities, shall be used. Test Certificates to be produced for BHEL verification and form part of the documentation.	
5.3.0	Welded Joints	To be followed for Girder Fabrication	
5.3.1	Number of Joints allowed	For Span upto 23 mtrs. - Two joints For Span 23 mtrs. to 32 mtrs. - Three joints	
5.3.2	Welding Electrodes	a. For all Horizontal Welding E 7018 /ER70S-6 (MIG) Electrode only should be used. b. For all Vertical Welding E 7048 /ER70S-6 (MIG) Electrode only should be used.	
5.3.3	Welded Joint Testing	All Butt Welded Joints (both compression / tension and flanges / web joints) shall be subjected to 100% X-Ray Testing and X-Ray Films to be produced for BHEL verification and form part of the documentation.	
5.4.0	Splice Joints	NO SPLICE JOINT IS ALLOWED IN GIRDER FABRICATION [Girder has to be of SINGLE PIECE only].	
5.5.0	Platform on Girders	The Platforms provided on both the Girders shall be fixed through BOLTED JOINTS only.	
5.6.0	Wheel Assembly	The Wheel Assembly coming for Cross Travel (CT) & Long Travel (LT) shall be of LIVE AXLE SYSTEM with L-Type Bearings. [Refer to BHEL Drawing No. 3-M-02R-0011993 . Drawing is enclosed and given as ANNEXURE -2].	

S.No.	PARTICULARS	BHEL SPECIFICATIONS	VENDOR's TECHNICAL OFFER (With Complete Details)
5.7.0	Heat Treatment & NDT Examination	The Trolleys shall be Stress Relieved after welding if necessary and NDT examinations. All weldings shall be tested by NDT means [MPI, LPI & RT] after Stress Relieving operation.	
5.8.0	Machining Operation	All mechanical mating surfaces and wheel seating areas are to be machined to the required finish and protected	
5.9.0	Surface Cleaning	Both the Girders and the Trolleys are to be thoroughly cleaned after completion of all operations but prior to painting.	
5.10.0	Painting	The crane parts are to be painted as follows : a. One coat of Primer with 25 microns of DFT (Dry Film Thickness) and 48 hours of compulsory curing after painting. b. Two coats of Enamel Paint (Colour – Tractor Orange) each with a DFT of 25 microns and intermittent curing of minimum 16 hours.	
6.0.0	MECHANICAL ELEMENTS		
6.1.0	Gears	Gears in all the Stages shall be helical in design and to be of machined, lapped and hardened if necessary.	
6.2.0	Gear Box Casing	Shall be of fabricated type and stress relieved by thermal heat-treatment process, prior to machining.	
6.3.0	Rope Drum	Shall be of fabricated type and stress relieved. The circumferential weld joints shall be tested by 100 % X-Ray for quality assurance.	

S.No.	PARTICULARS	BHEL SPECIFICATIONS	VENDOR's TECHNICAL OFFER (With Complete Details)
6.4.0	Type of Coupling	Only GEARED COUPLING to be used a. between Electric Motor and Gear Box b. between Gear Box and Rope Drum c. between Gear Box and Trolley Wheels	
6.5.0	Wheels	The Wheels shall be of Forged and Wheel Tread hardened to 300/350 BHN. Wheels shall be fitted with L-Type Bearings	
6.6.0	Mechanical Joints	Fit Bolts as per IS 3640-1982 for all joints coming in main members platform supports.	
6.7.0	Pulley Dimension	Rope Pulley diameter shall be 23 times that of Rope diameter	
6.8.0	Hook	Hook latch shall be provided for both hooks	
6.9.0	Gear & thruster oil	Required grade oil should be supplied	
6.10.0	Buffer	Spring loaded buffer shall be provided for Crab and bogies	
6.11.0	Tools	The following tools of makes acceptable to BHEL shall be supplied along with each crane Vendor to clearly specify the make of each items in the offer	
6.11.1	List of Tools	1 Double end spanner -one set 2 Ring spanner -one set 3 Hammer 2lbs -one no 4 Screw driver -one set 5 Screw spanner -one set 6 Cutting pliers -one set 7 line tester -one no 8 3T chain block -one no 9 30 T hydraulic Jack -one no 10 Grease gun -one no	

S.No.	PARTICULARS	BHEL SPECIFICATIONS	VENDOR's TECHNICAL OFFER (With Complete Details)
7.0.0	ELECTRICAL ELEMENTS		
7.1.0	Operational Controls	The Crane shall be provided with the following controls : a. Cabin Control [Master Control] b. Radio Remote Control [Micro processor based Two Step Push Button Type]	
7.2.0	Control Voltage	110 V AC	
7.3.0	Type of Brakes	a. Main Hoist - DC Brake b. Cross Travel - Thruster Brake c. Long Travel - Thruster Brake	
7.4.0	Protection	All Panels, Limit-Switches and Motors shall have IP 54 protection.	
7.5.0	Electric Motors	All Electric Motors shall be as per IS-325 and IS-1231 and also suitable for 300 starts per hour.	
7.6.0	Electric Contactors	All Panels shall have only SIEMENS / L&T Contactors and shall be suitable for AC3 Duty Class.	
7.7.0	Contactors Rating	The rating of all Contactors shall be atleast 50% higher than the respective electric motor full load current, at the specified duty cycle.	
7.8.0	Long Travel Motion	Dual Drive Mechanism shall be provided for LT (Long Travel) Motion.	

S.No.	PARTICULARS	BHEL SPECIFICATIONS	VENDOR'S TECHNICAL OFFER (With Complete Details)
7.9.0	Illumination	a. Four numbers of 500 Watts Halogen Lamps shall be provided in end carriage between bridges. b. All Electric Panels shall be provided with suitable illumination for visibility and trouble shooting.	
7.10.0	Controller Steps	A 4-Step Controller has to be provided for a. Main Hoist b. Long Travel c. Cross Travel	
7.11.0	Frequency Converter	The VVVF Drive shall be supplied with suitable DBR for all motions.	
7.12.0	Anti-Collision Device	An Anti-Collision Device of infra-red type shall be provided on both sides of the crane. The operating range shall be 3.0 metres to 10.0 metres.	
7.13.0	Load Cell	a. Load Weighing System with LOAD CELL (shear pin type) to be fixed / provided at the equalizer pulley. b. The display shall be of 100 mm size (JUMBO)	
7.14.0	Crab Wiring	Junction box shall be avoided for wiring of crab and in bridge end.	
7.15.0	Hoist limit	Each hoist shall be provided with both rotary and counter weight limits	
7.16.0	Cabin	Light, fan, warning bell and emergency push pushbutton shall be provided in the cabin	
8.0.0	SELECTION of BOI and COMPONENTS	The makes of Components or Bought-Out-Items shall be strictly as per the list given below.	

S.No.	PARTICULARS	BHEL SPECIFICATIONS	VENDOR's TECHNICAL OFFER (With Complete Details)
8.1.0	Hoist Hooks	HERMAN MOHTTA / HERCULES / SILPA UDYOG / SMRITI FORGINGS / KARACHIWALA	
8.2.0	Wire Rope	USHA MARTIN / FORT WILLIAM / RA WIRE ROPE	
8.3.0	Electric Motors	GEC / BHARAT BIJLEE / SIEMENS / KEC/ ALSTHOM	
8.4.0	DC Brake Unit	Only BCH make	
8.5.0	Radio Remote Control	Tele crane make(F24-10D) Ittowa make (winner)	
8.6.0	Thruster Brake Unit	ELECTROMAG / SPEED-O-CONTROL / OMEGA	
8.7.0	Limit Switch (Gravity Type)	SIEMENS / INDUSTRIAL SYNDICATE / BCH / SKC / SOC	
8.8.0	Contactors	SIEMENS / L&T	
8.9.0	Over-Load-Relay	SIEMENS /L&T (THERMAL TYPE)	
8.10.0	HRC Fuses	GE / L&T /SIEMENS	
8.11.0	Rotary limit switch	SIEMENS / OMEGA / SOC / INDUSTRIAL SYNDICATE	
8.12.0	Switch fuse unit	L&T / SIEMENS / GEC	
8.13.0	Moulded case C.B	SIEMENS / L&T	
8.14.0	Pneumatic Time Delay	Only BCH make	
8.15.0	Push - Buttons	SIEMENS / L&T /AIRON	
8.16.0	Connectors	ELMAX make or reputed make with IS approved and acceptable BHEL.	
8.17.0	Couplings	WMI / FENNER / ALFEX	
8.18.0	Bearings	SKF / NBC / ZKL	
8.19.0	Cables	Reputed Makes & IS Approved acceptable by BHEL.	

S.No.	PARTICULARS	BHEL SPECIFICATIONS	VENDOR's TECHNICAL OFFER (With Complete Details)
8.20.0	Bridge Light Fittings	PHILIPS / GE / CROMPTON	
8.21.0	Load Cell	IPA make or reputed make with IS approved and acceptable to BHEL	
8.22.0	VVVF Drives	ABB / SIEMENS / L&T	
9.0.0	DOCUMENTS/ DETAILS for APPROVAL	The following documents and details are to be submitted for BHEL Approval, prior to taking up the manufacture of the crane.	
9.1.0	Drawings and Documents	<p>Set I:</p> <ol style="list-style-type: none"> Calculations for Selection of Electric Motors, Gear Reducers, Brakes, Couplings, etc. Calculations for Bridge Girder, Crab, End - Carriage and their connections. GA Drawing of the Crane. GA Drawing of Trolley GA Drawing of Individual Mechanisms. <p>Set II:</p> <ol style="list-style-type: none"> Drawings of Bridge, End-Carriage bogies and their connection. Sub-Assembly Drawing for Wheels, Hook Blocks, Gear Boxes, Hoist rope drums and all brake Drums. Wiring Diagram with Logic Circuits. Cable Selection based on Current Rating. <p>Initially Set I drawings to be submitted in one lot and approval to be obtained from BHEL. Based on this, set II drawings to be submitted for approval.</p>	

S.No.	PARTICULARS	BHEL SPECIFICATIONS	VENDOR'S TECHNICAL OFFER (With Complete Details)
9.2.0	Technical Details	a. Total Weight of the Crane including all Electrical Equipment b. Total Weight of Trolley including all Electrical Equipment c. Weight of each Bridge assembled and ready for erection with and without Mechanical and Electrical Equipment. d. Weight of End-carriage assembled and ready for erection. e. Total Weight of Structural, Mechanical and electrical Equipment and indicated separately also. f. Weight of Operator's Cabin together with all Equipment mounted in it.	
10.0.0	INSPECTION	The following Schedule of Stage Inspections is to be strictly adhered to, prior to dispatch from the Supplier's Works	
10.1.0	STAGE – I	a. Verification of Test Certificate for Raw Materials used for Girders, End-Carriages, Trolley, Gear Box Casings, etc. b. Verification of X-Ray Report of Butt-Joints coming in the Girders and Random Testing on the Welds, by physical examination. c. Box Girder setting before closing of the Bottom Flanges – for inspecting the quality of welding and presence of waviness d. Trolley Frame Fabrication before setting the Mechanisms e. End-Carriage Fabrication before closing of the Bottom Flanges	

S.No.	PARTICULARS	BHEL SPECIFICATIONS	VENDOR'S TECHNICAL OFFER (With Complete Details)
10.2.0	STAGE – II	a. Inspection of Bridges, End–Carriages and platform fabrication. b. Verification of Span & Diagonal Dimensions, Checking of Wheel Alignment, Mechanical Assemblies and Total Alignment. c. Free running of all the Mechanisms. d. Measurement of CAMBER in the Bridges. e. Full / Rated Load Test for bridges and trolley and Deflection Test f. Deflection and Permanent Set Measurement. g. 25% OVER-LOAD Lifting Ability Check.	
11.0.0	CRANE ERECTION & COMMISSIONING		
11.1.0	Mechanical Erection	Erection of the Crane will be done by BHEL, as per the guidelines furnished in the Erection Manual given by the Supplier	
11.2.0	Crane Commissioning	Commissioning of the Crane and Performance Prove –Out for 125% of Crane's Capacity and Smooth Functioning of the Crane (at BHEL Works) shall be the RESPONSIBILITY of the supplier.	
12.0.0	O & M MANUALS	Each Crane shall be provided with complete set of tools required for maintenance, THREE Copies of Erection, Operation & Maintenance Manual hard copy and soft copy in CD, containing the following technical details	

S.No.	PARTICULARS	BHEL SPECIFICATIONS	VENDOR's TECHNICAL OFFER (With Complete Details)
12.1.0	Drawings & Details	a. Crane GA Drawing b. Crab Assembly Drawing c. Total Crane Wiring Schematics d. Detailed Wiring Diagrams for Sub-Systems /Panels e. VVVF Drive's Logic Circuits f. Wheel Assembly Drawings g. Bottom Block Assembly Drawing h. Gear Box Assembly Drawings i. Coupling Drawing and Details j. Specifications/Ratings of All Bought-Out-Items k. Warranty/Guarantee Card for all Bought Out-items l. Trouble Shooting Chart for all Systems	
13.0.0	PERFORMANCE GUARANTEE	The Performance of the Total Crane and/or the Components / Sub-Assemblies / Bought-Out-Items shall be guaranteed for a minimum period of 12 months from the date of performance acceptance at BHEL Works or 18 months from the date of supply whichever is earlier.	

THIS DRAWING IS OUR SOLE PROPERTY AND SHOULD NOT BE USED IN ANY FORM FOR ANY PURPOSE WITHOUT THE WRITTEN PERMISSION OF BHARAT HEAVY ELECTRICALS LIMITED, TRICHIRAPPALLI - 620 014.

ALL DIMENSIONS ARE IN MM

SL. No.	W.D. (WHEEL DIA) IN MM	RAIL SIZE	A	B	D	E	F	ØG	H	ØJ	K	L	Ød	M (KEY)	N	P	Q	S	R	COUPLING No.	SKF BRG No. & BRG. SIZE	TOTAL WEIGHT IN Kg. FOR DRIVE & IDLE
16	800/850	CR-100 CR-120	190	450	80	210	150	152	140	130	212	255	32	32x18x130	687	588	20	150	80	107	22330 150x320x108	870.00 845.00
15		CR-80	168	420	80	180	110	152	125	110	212	255	32	28x16x115	687	588	20	150	80	106	22330 150x320x108	796.00 775.00
14	710/750	CR-100 CR-120	190	450	80	210	150	152	140	130	212	255	32	32x18x130	642	588	20	150	80	107	22330 150x320x108	808.00 784.00
13		CR-100 CR-120	180	420	71	210	150	132	125	110	180	224	32	28x16x115	607	517	20	130	80	106	22326 130x280x93	728.50 711.50
12	630/680	CR-80	180	400	71	180	110	132	125	110	180	224	32	28x16x115	607	517	20	130	80	106	22326 130x280x93	653.00 636.00
11		CR-80/CR-100 & CR-120	180	420	71	210	150	132	125	110	180	224	32	28x16x115	567	517	20	130	80	106	22326 130x280x93	629.00 611.50
10	500/550	90-105 Lbs/Yd CR-80	150	365	60	180	105	111	110	90	160	190	26	25x14x100	547	462	20	120	60	105	22322 110x240x80	448.00 434.50
9		CR-80 CR-100	160	375	60	180	125	111	110	90	160	190	26	22x14x100	482	462	20	120	60	105	22322 110x240x80	253.00 245.50
8	400/450	CR-80	150	360	50	180	125	91	105	80	125	160	26	22x14x90	445	395	20	100	50	104	22318 90x190x64	389.00 378.00
7		60/75/90 & 105 Lbs/Yd	150	360	50	180	105	91	105	80	125	160	26	22x14x90	445	395	20	100	50	104	22318 90x190x64	301.00 294.00
6	320/370	CR-80 CR-100	150	360	50	180	125	91	105	80	125	160	26	22x14x90	395	395	20	100	50	104	22318 90x190x64	253.00 245.50
5		90 Lbs/Yd 105 Lbs/Yd	145	315	40	180	105	76	85	70	112	140	22	20x12x75	375	345	16	90	50	103	22315 75x160x55	197.00 192.00
4	250/280	75 / 90 & 105 Lbs/Yd CR-80	145	315	40	180	105	76	85	70	112	140	22	20x12x75	345	345	16	90	50	103	22315 75x160x55	162.00 157.00
3		50 SQ.BAR 60 Lbs/Yd 75 Lbs/Yd	112.5	260	40	125	85	61	65	55	85	112	17	16x10x55	312	287	16	80	50	102	22312 60x130x46	118.50 118.00
2	200/230	50 SQ.BAR 60 / 90 & 105 Lbs/Yd	105	250	32	125	85	61	65	55	76	100	17	16x10x55	254	249	12	60	40	102	22212 60x110x28	66.00 63.00
1		50 Lbs/Yd 50 SQ.BAR 80 Lbs/Yd	95	220	32	100	67	46	55	40	71	95	17	12x8x45	239	232	12	65	40	101	22309 45x100x36	51.00 50.00

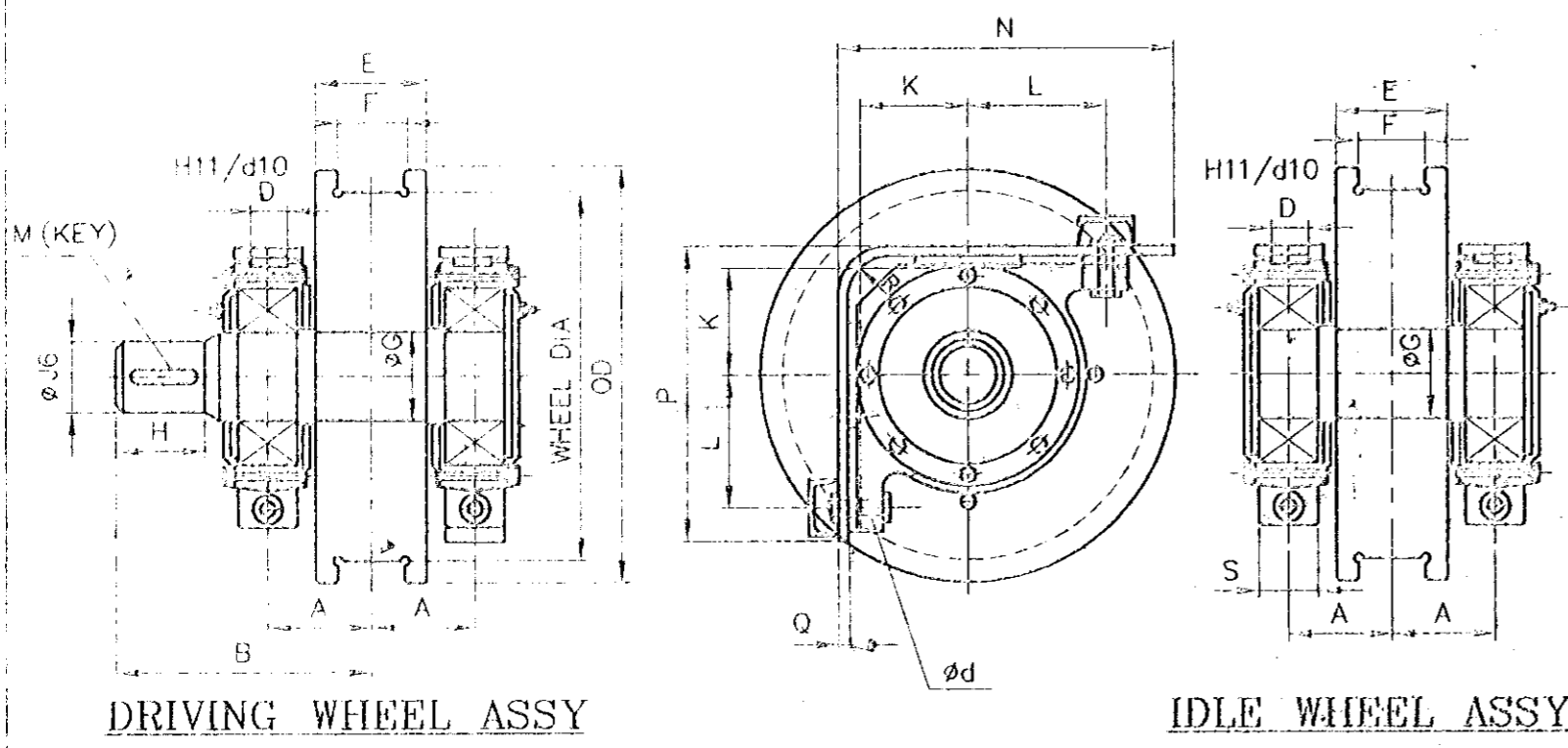

MATERIAL :- SHAFT - 45CB/IS:4283.
WHEEL - 55CB/IS:5517.
FORGED.
THREAD PORTION WHEEL HARDNESS 300 TO 350 (BHN)

DESCRIPTION	MATERIAL	STANDARD	NET.WT.IN KGS.	DRAWING No.	ITEM No.
REFERENCE:			COMPONENT CODE: 29	EQUIPMENT CODE: 00	
SCALE	DRAWN	CHECKED	APPROVED	DATE	
				20-10-2000	
MACHINE: CRANE WHEEL ASSY			TYPE: GENERAL		
TITLE: STANDARD CRANE WHEEL ASSY			DRAWING No. 3-M-02R-11993		
No. of Sheets			Sheet No.		