

DRAWING NO.

THE INFORMATION ON THIS DOCUMENT IS THE PROPERTY OF BHARAT HEAVY ELECTRICALS LIMITED. IT MUST NOT BE USED DIRECTLY OR INDIRECTLY IN ANY WAY DETERIMENTAL TO THE INTEREST OF THE COMPANY

REF.DRG.NO.

SIGN AND DATE

INVENTORY NO.

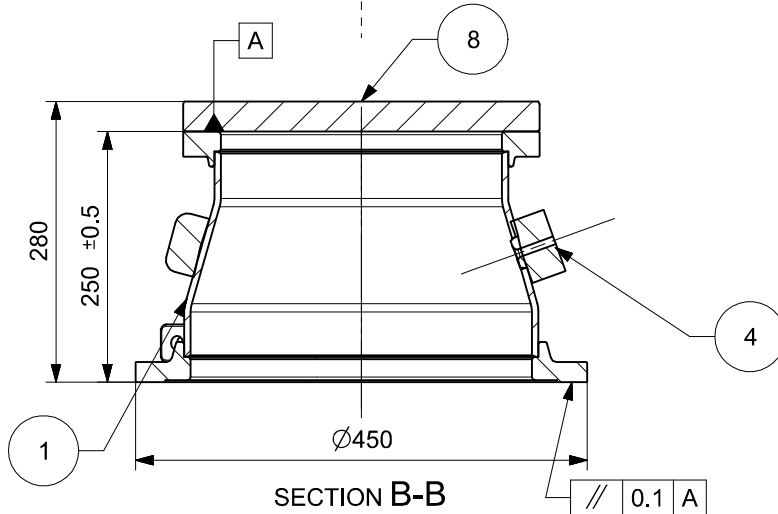
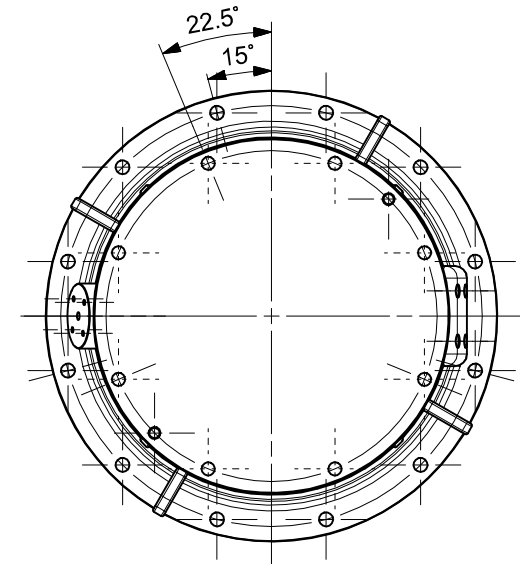
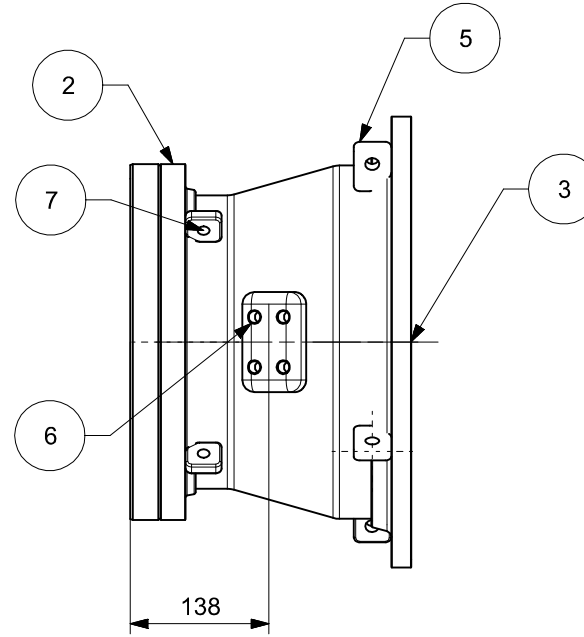
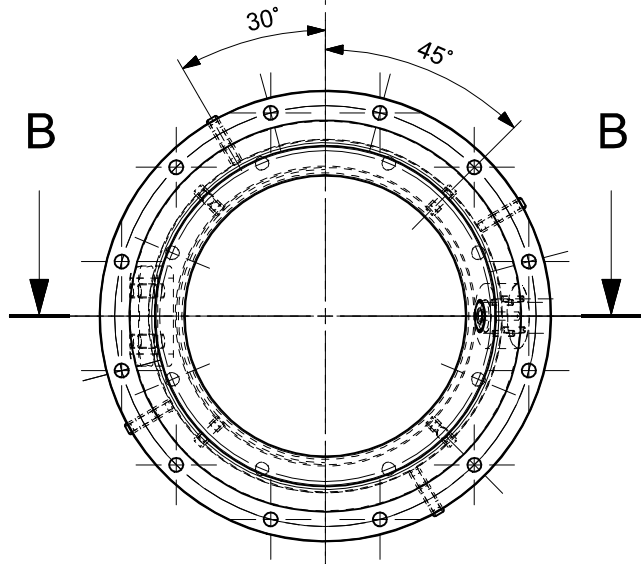

- NOTE:**
1. PIPE AND FLANGE TO BE MIG/TIG WELDED WITH SUITABLE SS ELECTRODE
 2. THE ROOT SHOULD BE HOMOGENEOUS AND CONTINUOUS.
 3. TESTED ASSEMBLIES TO BE DEGREASED, SAND BLASTED AND POWDER COATED ON OUTSIDE WITH SHADE RAL5015 (BLUE).
 4. ELECTRO POLISH INSIDE SURFACE.

VA R. NO	REMA RKS	ITE M NO.	DESCRIPTION	STD	DRAWING NO.	IT. N O.	VA R.	MATL. COD E	MATL. SPCN.	A C	UNIT	UNI T WT.	QT Y	GS	ZONE
		8	DUMMY PLATE - PT		RDDG43505170817			EN8				23	1		
		7	LIFTING LUG II		RDDG43505170818			SS304L					4		
		6	EARTHING PLATE		RDDG43505170080			SS304L					1		
		5	LIFTING LUG		RDDG43505170812			SS304L					4		
		4	GAS PORT FLANGE		RDDG43505170059			SS304L				1	1		
		3	FLANGE II		RDDG43505170013			SS304L				12	1		
		2	PT FLANGE		RDDG43505170815			SS304L				7	1		
		1	PT REDUCER PIPE		RDDG43505170814			SS304L				10	1		

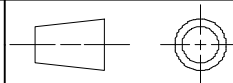
TYPE OF PRODUCT OR NAME OF CUSTOMER/PROJECT				GSM - 245			
		BHARAT HEAVY ELECTRICALS LIMITED, CORPORATE R & D, HYDERABAD		DRN.	NT	29.07.2020	NO. OF VAR
				CKD.	NT	29.07.2020	
				APPD.	MMR	29.07.2020	
DPT.GSG	UNTL. DMS. GR.		SCALE	WEIGHT(K.G.)	REF. TO ASSY. DRG.	ITEM NO.	NO. OF ITEMS
CODE 35			NTS		RDDG43505170800		
TITLE				DRAWING NO.		REV NO.	
REDUCER ASSEMBLY-PT				RD DG 4 3505170813		-	
				SHT NO. 1		NO. OF SHT. 1	

DRAWING NO.

THE INFORMATION ON THIS DOCUMENT IS THE PROPERTY OF BHARAT HEAVY ELECTRICALS LIMITED IT MUST NOT BE USED DIRECTLY OR INDIRECTLY IN ANY WAY DETERMENTAL TO THE INTEREST OF THE COMPANY

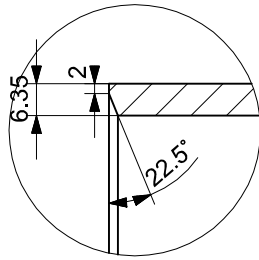
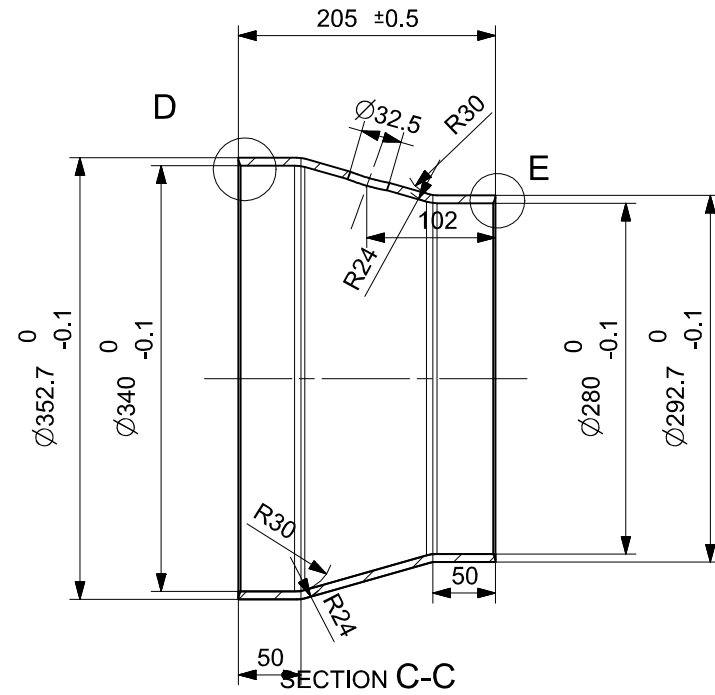
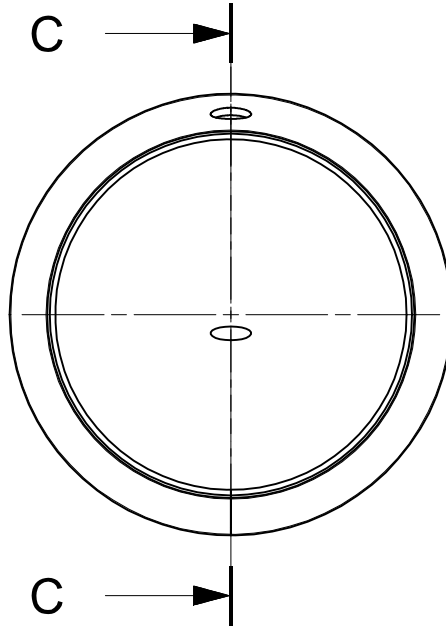

DETAIL D
SCALE 1:1

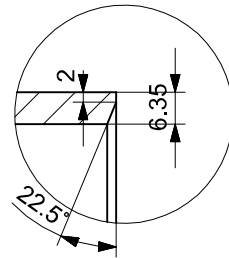

DETAIL E
SCALE 1:1

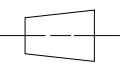
VAR. NO.	REMARKS	ITEM NO.	DESCRIPTION	STD	DRAWING NO.	IT. NO.	VAR.	MATL. CODE	MATL. SPCN.	A	C	UNIT	UNIT WT.	QTY	GS	ZONE
									SS304L							
TYPE OF PRODUCT OR NAME OF CUSTOMER/PROJECT										GSM - 245						
 BHARAT HEAVY ELECTRICALS LIMITED, CORPORATE R & D, HYDERABAD										DRN.	NT	27.07.2020	NO. OF VAR			
										CKD.	NT	27.07.2020				
										APPD.	MMR	27.07.2020				
DPT.GSG	UNTOL. DMS. GR.			SCALE	WEIGHT(K.G.)	REF. TO ASSY. DRG.	ITEM NO.	NO. OF ITEMS								
CODE 35				NTS	10.3	RDDG43505170813										
TITLE										DRAWING NO.		REV NO.				
PT REDUCER PIPE										RD DG 4 35 0517 0814		-				
SHT NO. 1											NO. OF SHT. 1					

DRAWING NO.

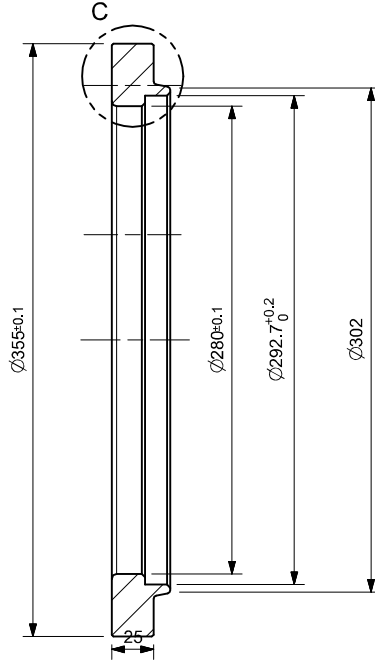

SECTION B-B

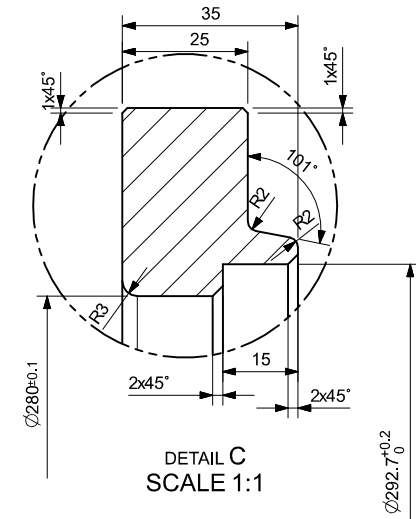
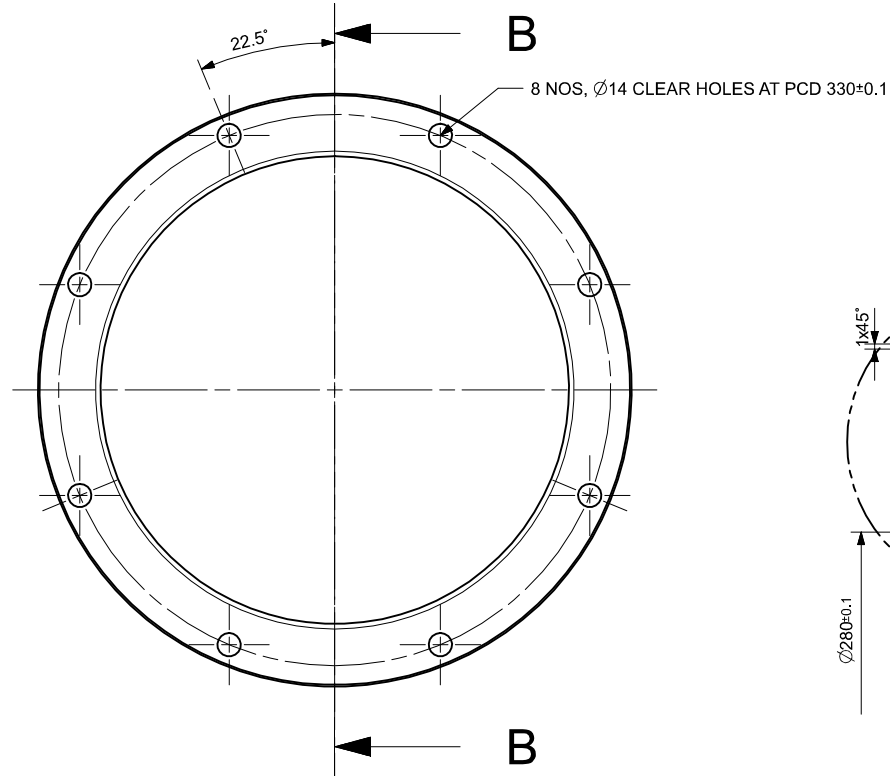

DETAIL C
SCALE 1:1

NOTE:

1. SEALING AREA SHALL BE POLISHED TO 0.8 OR BETTER.
2. $\varnothing 14$ HOLED SHALL BE CHAMFERED UNIFORMLY (0.4X45°).
3. PCD AND FLANGE SHALL BE CONCENTRIC WITHIN ± 0.1 .
4. FINISHED FLANGE SHALL BE DEGREASED AND PACKED IN 125 MICROM POLYBAG AND SEALED.
5. COMPONENT SHLL BE MACHINED TO DIMENTION AFTER WELDING TO PIPE.

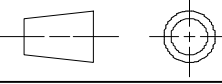
										SS304L							
VAR. NO.	REMARKS	ITEM NO.	DESCRIPTION	STD	DRAWING NO.	IT. NO.	VAR.	MATL. CODE	MATL. SPCN.	A	UNIT	UNIT WT.	QTY	GS	ZONE		
TYPE OF PRODUCT OR NAME OF CUSTOMER/PROJECT										GSM 245							
 BHARAT HEAVY ELECTRICALS LIMITED, CORPORATE R & D, HYDERABAD										DRN.	NSK	08.02.2019	NO. OF VAR				
										CKD.	NT	08.02.2019					
										APPD.	MMR	08.02.2019					
DPT.GSG	UNTOL. DMS. GR.			SCALE	WEIGHT(K.G.)	REF. TO ASSY. DRG.	ITEM NO.	NO. OF ITEMS									
CODE 35				NTS	7.2	RDDG43505170813											
TITLE										DRAWING NO.		REV NO.					
PT FLANGE										RD DG 4 35 0517 0815		-					
										SHT NO. 1	NO. OF SHT. 1						

THE INFORMATION ON THIS DOCUMENT IS THE PROPERTY OF BHARAT HEAVY ELECTRICALS LIMITED IT MUST NOT BE USED DIRECTLY OR INDIRECTLY IN ANY WAY DETERMINAL TO THE INTEREST OF THE COMPANY

REF.DRG.NO.

SIGN AND DATE

INVENTORY NO.

DRAWING NO.

THE INFORMATION ON THIS DOCUMENT IS THE PROPERTY OF BHARAT HEAVY ELECTRICALS LIMITED IT MUST NOT BE USED DIRECTLY OR INDIRECTLY IN ANY WAY DETERMINAL TO THE INTEREST OF THE COMPANY

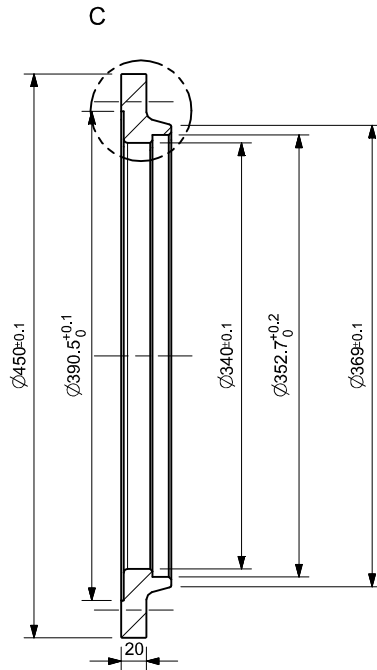

SECTION B-B

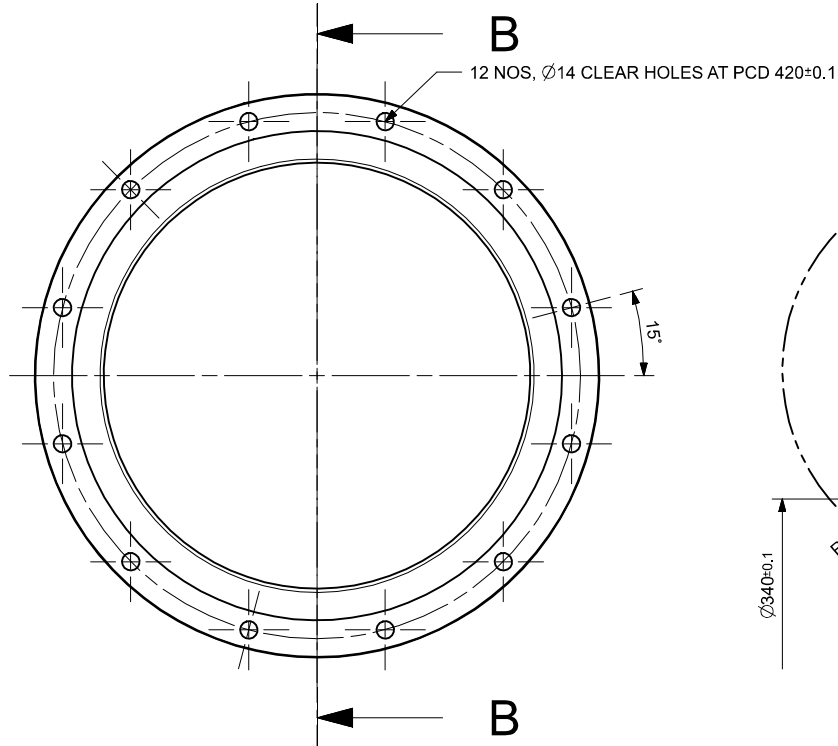

B

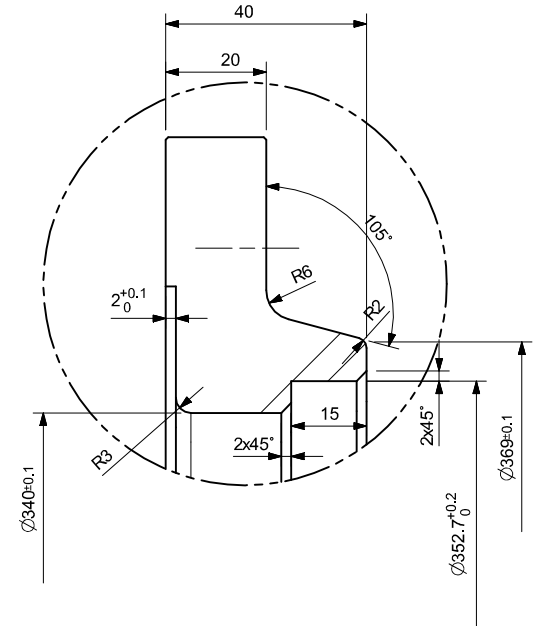

DETAIL C
SCALE 1:1

NOTE:

1. SEALING AREA SHALL BE POLISHED TO 0.8 OR BETTER.
2. $\varnothing 14$ HOLED SHALL BE CHAMFERED UNIFORMLY (0.4X45°).
3. PCD AND FLANGE SHALL BE CONCENTRIC WITHIN ± 0.1 .
4. FINISHED FLANGE SHALL BE DEGREASED AND PACKED IN 125 MICROM POLYBAG AND SEALED.
5. COMPONENT SHLL BE MACHINED TO DIMENTION AFTER WELDING TO PIPE.

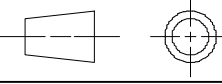
VAR. NO.	REMARKS	ITEM NO.	DESCRIPTION	S/D	DRAWING NO.	IT. NO.	VAR.	MATL. CODE	MATL. SPCN.	SS304L	A	UNIT	UNIT WT.	QTY	GS	ZONE	
TYPE OF PRODUCT OR NAME OF CUSTOMER/PROJECT										GSM 245							
 BHARAT HEAVY ELECTRICALS LIMITED, CORPORATE R & D, HYDERABAD											DRN.	NSK	08.02.2019	NO. OF VAR			
											CKD.	NT	08.02.2019				
											APPD.	MMR	08.02.2019				
DPT. GSG	UNTOL. DMS. GR.			SCALE	WEIGHT (K.G.)	REF. TO ASSY. DRG.	ITEM NO.	NO. OF ITEMS									
CODE 35				NTS	12.24												
TITLE											DRAWING NO.		REV NO.				
FLANGE II											RD DG 4 35 0517 0013		-				
											SHT NO. 1	NO. OF SHT. 1					

DRAWING NO.

THE INFORMATION ON THIS DOCUMENT IS THE PROPERTY OF BHARAT HEAVY ELECTRICALS LIMITED. IT MUST NOT BE USED DIRECTLY OR INDIRECTLY IN ANY WAY DETERMINAL TO THE INTEREST OF THE COMPANY

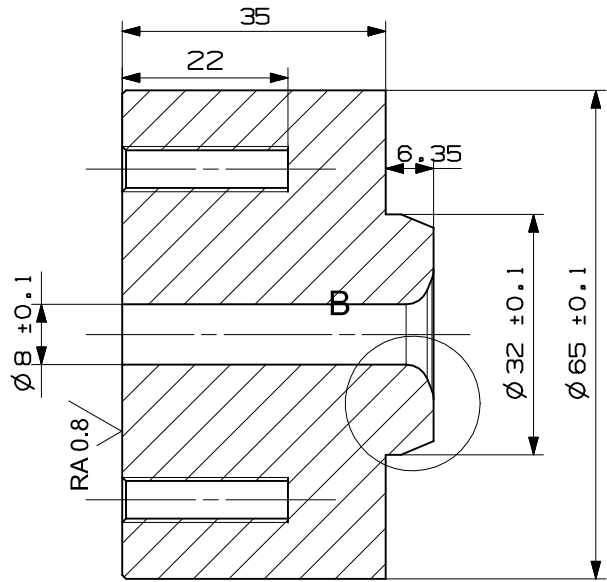

SECTION A-A

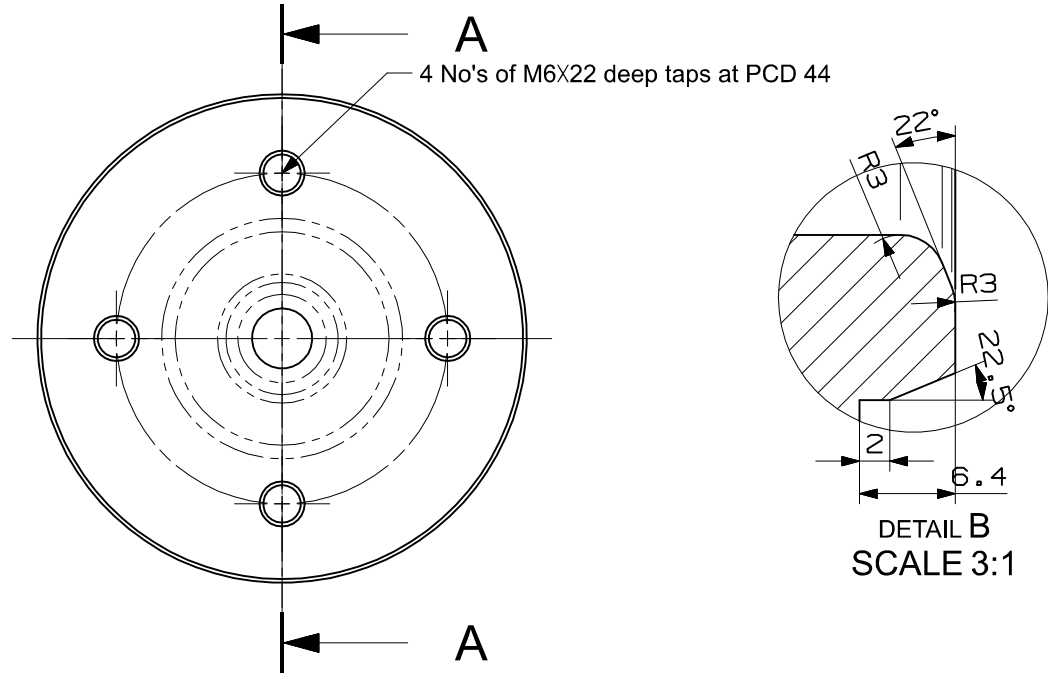

DETAIL B
SCALE 3:1

NOTE:

1. $\phi 6$ HOLES TO BE CHAMFERED UNIFORMLY TO $0.8 \times 45^\circ$.
2. PCD AND FLANGE CENTRE SHALL BE CONCENTRIC WITHIN ± 0.05 AFTER WELDING TO PIPE.
3. COMPONENT SHALL BE MACHINED TO DIMENTIONS AFTER WELDING TO PIPE.

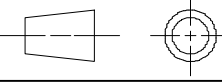
BLOCK			DIA 70 X 45			SS304L									
VAR. NO.	REMARKS	ITEM NO.	DESCRIPTION	STD	DRAWING NO.	IT. NO.	VAR.	MATL. CODE	MATL. SPCN.	A/C	UNIT	UNIT WT.	QTY	GS	ZONE
TYPE OF PRODUCT OR NAME OF CUSTOMER/PROJECT								GSM - 245							
 BHARAT HEAVY ELECTRICALS LIMITED, CORPORATE R & D, HYDERABAD								DRN.	NT		28.07.2020	NO. OF VAR			
								CKD.	NT		28.07.2020				
								APPD.	MMR		28.07.2020				
DPT. GSG	UNTO. DMS. GR.			SCALE	WEIGHT (K.G.)	REF. TO ASSY. DRG.	ITEM NO.	NO. OF ITEMS							
CODE 35				NTS	1	RDDG43505170813									
TITLE								DRAWING NO.		REV NO.					
GAS PORT FLANGE								RD DG 4 35 0517 0059		-					
								SHT NO. 1		NO. OF SHT. 1					

DRAWING NO.

THE INFORMATION ON THIS DOCUMENT IS THE PROPERTY OF BHARAT HEAVY ELECTRICALS LIMITED. IT MUST NOT BE USED DIRECTLY OR INDIRECTLY IN ANY WAY DETERMINAL TO THE INTEREST OF THE COMPANY

REF.DRG.NO.

SIGN AND DATE

INVENTORY NO.

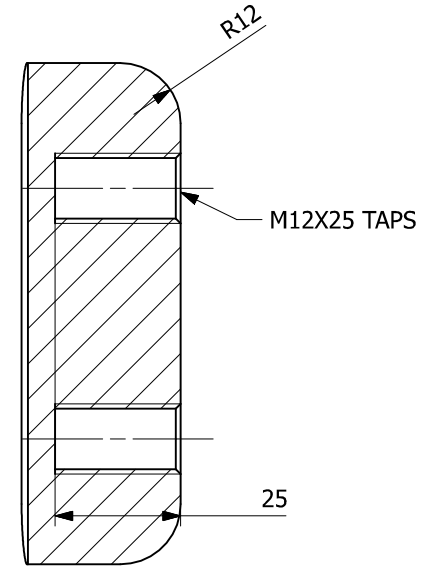
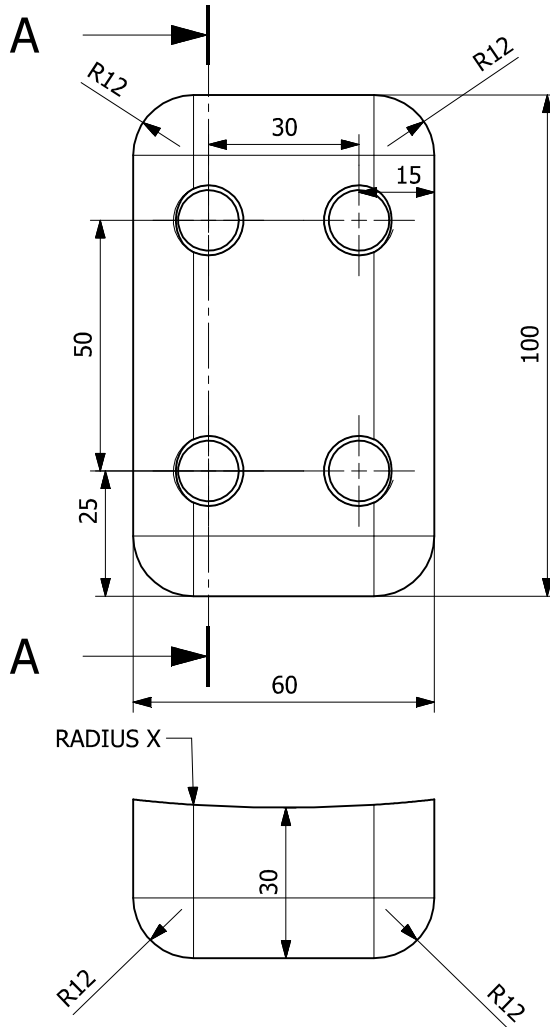

SECTION A-A

NOTE:

- 'RADIUS X' SHALL BE MADE ACCORDING TO THE RADIUS OF ENCLOSURE
- TOP SURFACE OF EARTHING PLATE SHALL NOT BE PAINTED.

VAR. NO.	REMARKS	ITEM NO.	DESCRIPTION	STD	DRAWING NO.	IT. NO.	VAR.	MATL. CODE	MATL. SPCN.	A/C	UNIT	UNIT WT.	QTY	GS	ZONE
			SS BLOCK						SS304L						
TYPE OF PRODUCT OR NAME OF CUSTOMER/PROJECT															
BHARAT HEAVY ELECTRICALS LIMITED, CORPORATE R & D, HYDERABAD											DRN.	NT	15.01.2020	NO. OF VAR	
											CKD.	MMR	15.01.2020		
											APPD.	MMR	15.01.2020		
DPT.GSG	UNTOL. DMS. GR.			SCALE	WEIGHT(K.G.)	REF. TO ASSY. DRG.	ITEM NO.	NO. OF ITEMS							
CODE 35				NTS											
TITLE										DRAWING NO.		REV NO.			
EARTHING PLATE										RD DG 435 0517 0080		-			
											SHT NO. 1	NO. OF SHT. 1			

DRAWING NO.

THE INFORMATION ON THIS DOCUMENT IS THE PROPERTY OF BHARAT HEAVY ELECTRICALS LIMITED. IT MUST NOT BE USED DIRECTLY OR INDIRECTLY IN ANY WAY DETERMINAL TO THE INTEREST OF THE COMPANY

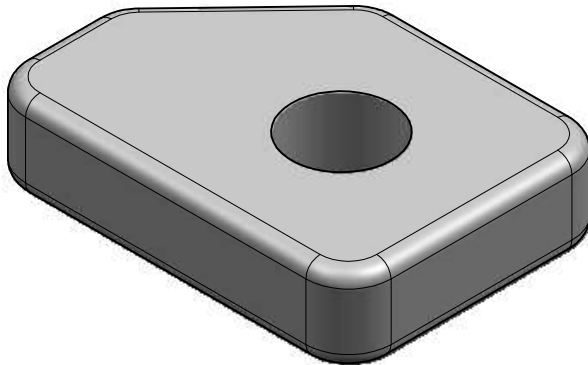
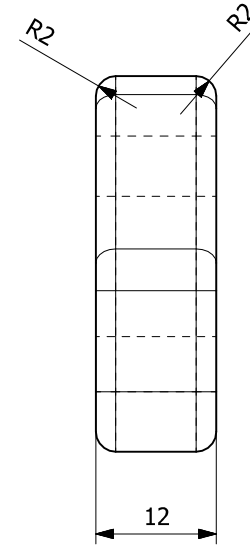
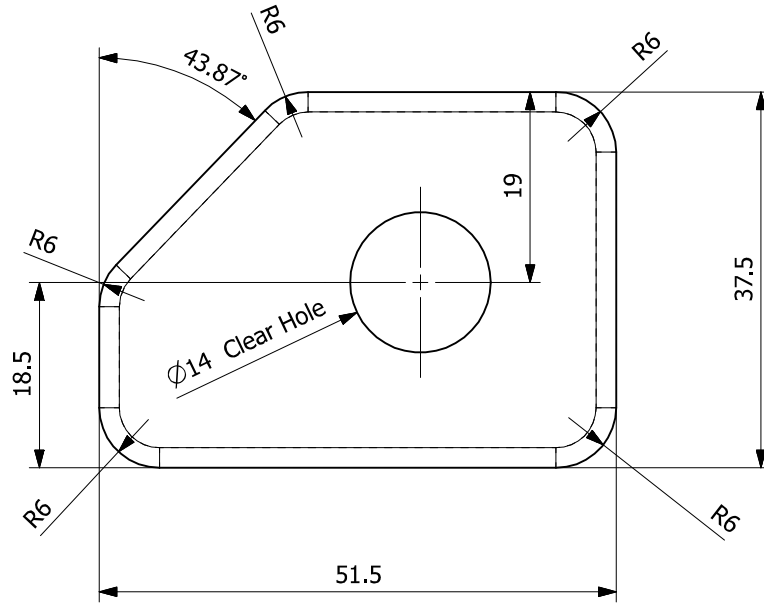

REF.DRG.NO.

SIGN AND DATE

INVENTORY NO.

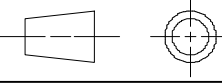
VAR. NO.	REMARKS	ITEM NO.	DESCRIPTION	STD	DRAWING NO.	IT. NO.	VAR.	MATL. CODE	MATL. SPCN.	A C	UNIT	UNIT WT.	QTY	GS	ZONE
			SS PLATE						SS304L						
TYPE OF PRODUCT OR NAME OF CUSTOMER/PROJECT															
 BHARAT HEAVY ELECTRICALS LIMITED, CORPORATE R & D, HYDERABAD										DRN.	NT	16.07.2020	NO. OF VAR		
										CKD.	MMR	16.07.2020			
										APPD.	MMR	16.07.2020			
DPT.GSG	UNTOL. DMS. GR.			SCALE	WEIGHT(K.G.)	REF. TO ASSY. DRG.	ITEM NO.	NO. OF ITEMS							
CODE 35				NTS		RDDG43505170810									
TITLE										DRAWING NO.		REV NO.			
LIFTING LUG										RD DG 435 0517 0812		-			
SHT NO. 1											NO. OF SHT. 1				

DRAWING NO.

THE INFORMATION ON THIS DOCUMENT IS THE PROPERTY OF BHARAT HEAVY ELECTRICALS LIMITED. IT MUST NOT BE USED DIRECTLY OR INDIRECTLY IN ANY WAY DETERMENTAL TO THE INTEREST OF THE COMPANY

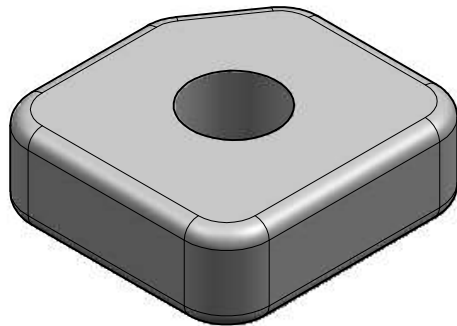
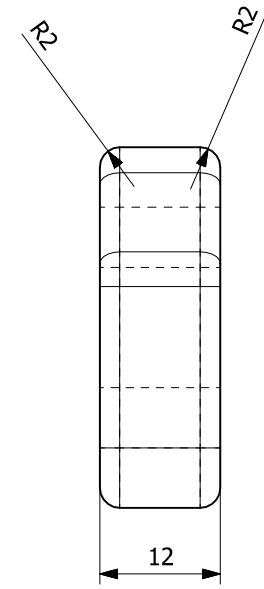
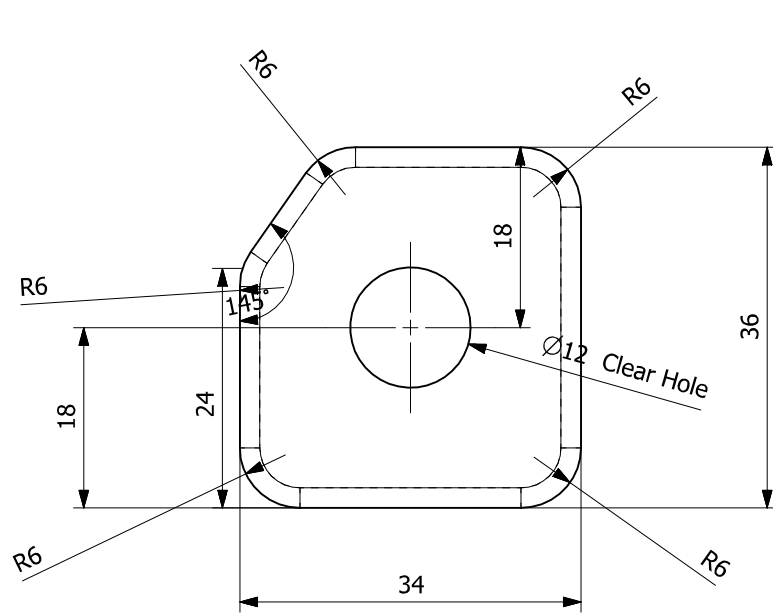

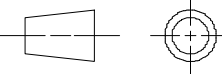
VAR. NO.	REMARKS	ITEM NO.	DESCRIPTION	STD	DRAWING NO.	IT. NO.	VAR.	MATL. CODE	MATL. SPCN.	A	C	UNIT	UNIT WT.	QTY	GS	ZONE
			SS PLATE						SS304L							
TYPE OF PRODUCT OR NAME OF CUSTOMER/PROJECT									GSM - 245							
 BHARAT HEAVY ELECTRICALS LIMITED, CORPORATE R & D, HYDERABAD										NAME	SIGN.	DATE	NO. OF VAR.			
										DRN.	NT	16.07.2020				
										CKD.	NT	16.07.2020				
										APPD.	MMR	16.07.2020				
DPT.GSG	UNTOL. DMS. GR.			SCALE	WEIGHT(K.G.)	REF. TO ASSY. DRG.	ITEM NO.	NO. OF ITEMS								
CODE 35				NTS		RDDG43505170810										
TITLE										DRAWING NO.		REV NO.				
LIFTING LUG II										RD DG 435 0517 0818		-				
										SHT NO. 1		NO. OF SHT. 1				

DRAWING NO.

THE INFORMATION ON THIS DOCUMENT IS THE PROPERTY OF BHARAT HEAVY ELECTRICALS LIMITED. IT MUST NOT BE USED DIRECTLY OR INDIRECTLY IN ANY WAY DETERIMENTAL TO THE INTEREST OF THE COMPANY

REF.DRG.NO.

SIGN AND DATE

INVENTORY NO.

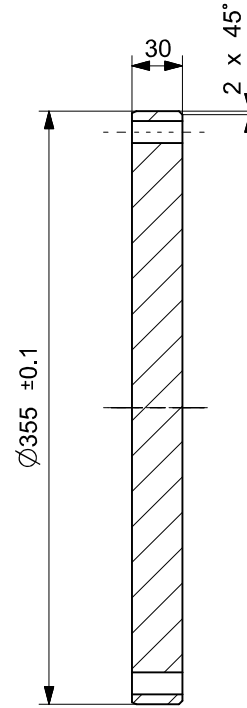
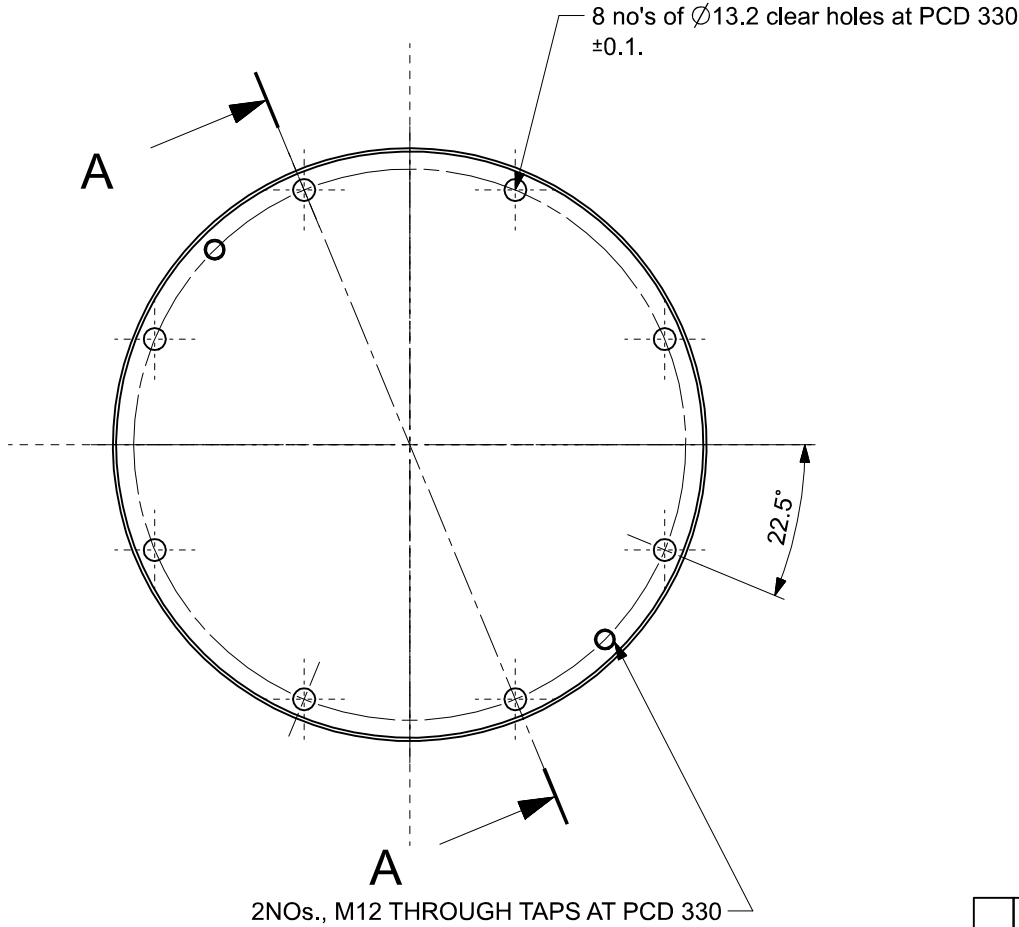

SECTION A-A

NOTE:

1. ALL SHARP EDGES TO BE MACHINED TO $0.4 \times 45^\circ$.
2. SURFACE SHALL BE MACHINED TO RA0.6
3. ITEM SHALL BE ZINC PACIFIED.

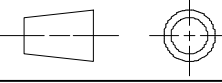
VAR. NO.	REMARKS	ITEM NO.	DESCRIPTION	STD	DRAWING NO.	IT. NO.	VAR.	MATL. CODE	MATL. SPCN.	A	C	UNIT	UNIT WT.	QTY	GS	ZONE
									EN8							
TYPE OF PRODUCT OR NAME OF CUSTOMER/PROJECT										GSM - 245						
 BHARAT HEAVY ELECTRICALS LIMITED, CORPORATE R & D, HYDERABAD										DRN.	NT	27.07.2020	NO. OF VAR			
										CKD.	NT	27.07.2020				
										APPD.	MMR	27.07.2020				
DPT.GSG	UNTO. DMS. GR.			SCALE	WEIGHT(K.G.)	REF. TO ASSY. DRG.	ITEM NO.	NO. OF ITEMS								
CODE 35				NTS	22.96	RDDG43505170800										
TITLE										DRAWING NO.		REV NO.				
DUMMY PLATE - PT										RD DG 4 35 0517 0817		-				
										SHT NO. 1		NO. OF SHT. 1				