

DRAWING NO. RDDG434026\_1000

(~3.2)

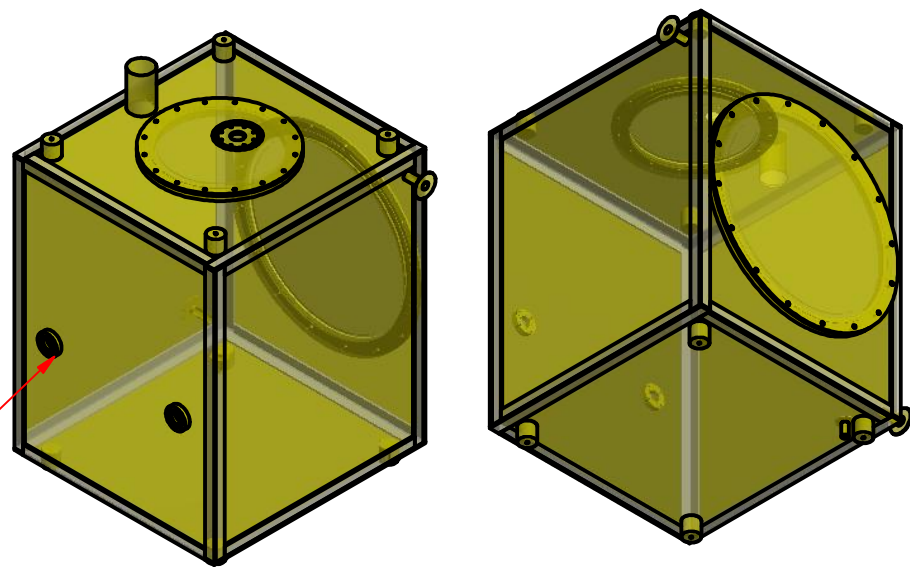
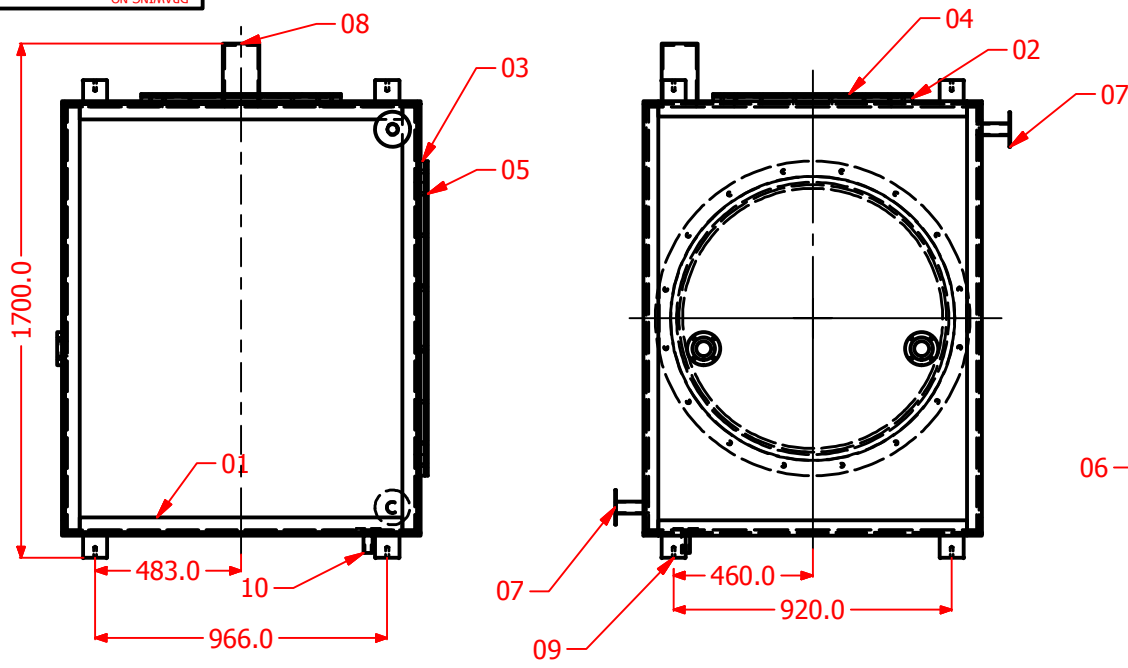

NOTE :

1. ALL ITEMS ARE ACRYLIC WELDED TO BASE CELL AS SHOWN.
2. ALL ACRYLIC WELDED JOINTS ARE COMPLETELY LEAK PROOF. NO LEAKAGE OF OIL FROM WELDED JOINTS.
3. 4 SUPPORT BUSHES ARE WELDED AT BOTTOM AND 4 SUPPORT BUSHES ARE WELDED AT TOP OF SAME DIMENSIONS AS BOTTOM.

ITEM NO.	DESCRIPTION	DRAWING NO.	MATL. CODE	UNIT	QTY.	UNIT WT.	ZONE
10	DRAIN BUSH	RDDG434026_1009	ACRYLIC		0.06		
09	SUPPORT BUSH	RDDG434026_1008	ACRYLIC		0.47		
08	BREATHER	RDDG434026_1007	ACRYLIC		0.49		
07	INLET/OUTLET PIPE	RDDG434026_1006	ACRYLIC		0.08		
06	FLANGE_BACK	RDDG434026_1005	ACRYLIC		0.21		
05	SIDE COVER FLANGE	RDDG434026_1004	ACRYLIC		11.23		
04	TOP COVER FLANGE	RDDG434026_1003	ACRYLIC		4.25		
03	SIDE BASE FLANGE	RDDG434026_1002	ACRYLIC		6.03		
02	TOP BASE FLANGE	RDDG434026_1001	ACRYLIC		3.73		
01	BASE CELL	RDDG434026_1100	ACRYLIC		110.58		

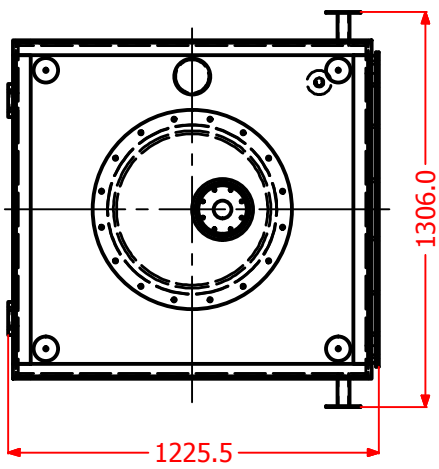

REMARKS	VAR. NO.	ITEM NO.	DESCRIPTION	DRAWING NO.	FT. NO.	MATL. CODE	UNIT	QTY.	ZONE

ADDITIONAL INFORMATION				TYPE OF PRODUCT				
STATUS OF DRAWING				OPTIMIZATION OF LEAD INSULATION FOR POWER TRANSFORMERS OR				
DISTRIBUTION OF PRINTS				NAME OF CUSTOMER / PROJECT				
R&D	HVE	QCX		BHARAT HEAVY ELECTRICALS LTD. CORPORATE R&D				
1	1	1		DRN.	MISHRA	SIGN	DATE	NO. OF VAR.
				CKD.	APC		12/2/2021	
				APPD	SNK		12/14/2021	
DEPT	UNTL. DIMS. GR.	SCALE	WEIGHT (KG.)	REF. TO. ASSY. DRG.	ITEM NO.	NO. OF ITEM		
HVE		1 : 1	140.727	RDDG434026_0000				
CODE								
34								
TITLE				DRAWING NO.				
TEST CELL ASSEMBLY				RDDG434026_1000				
SHEET NO.				NO. OF SHEETS				

INVENTORY NO. SIGN. & DATE REF. DRG. NO. THE INFORMATION ON THIS DOCUMENT IS THE PROPERTY OF BHARAT HEAVY ELECTRICALS LIMITED. IT IS NOT TO BE DISSEMINATED TO ANY OTHERS WITHOUT THE PERMISSION OF THE COMPANY.

REV.	DATE	ALTERED	REV.	DATE	ALTERED	REV.	DATE	ALTERED	REV.	DATE	ALTERED
		CHECKED			CHECKED			CHECKED			CHECKED
		APPROVED			APPROVED			APPROVED			APPROVED
ZONE			ZONE			ZONE			ZONE		

DRAWING NO. RDDG434026\_1100

(~3.2)

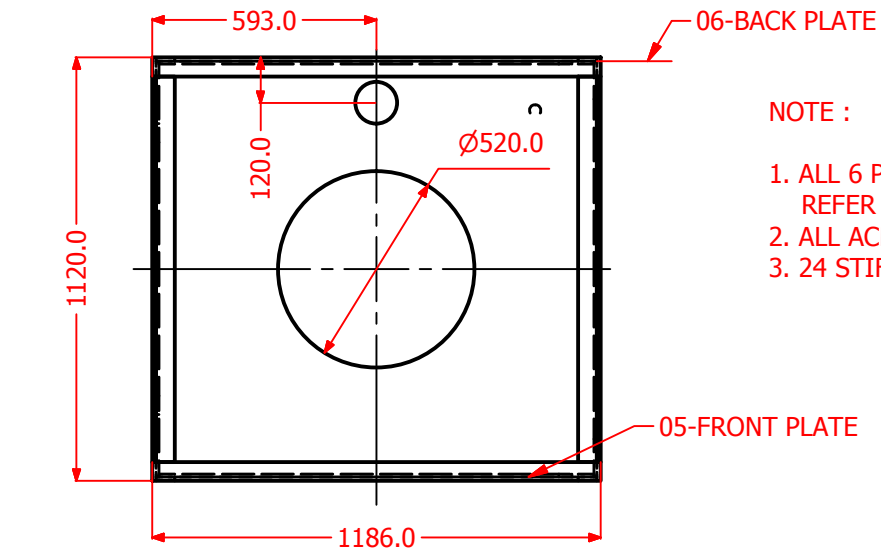
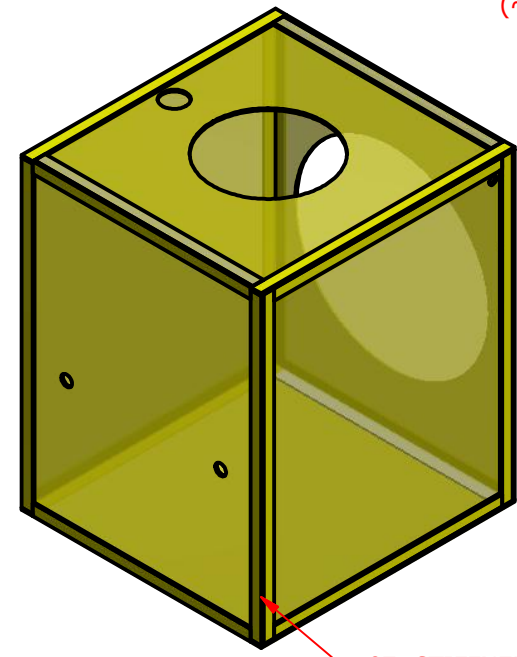
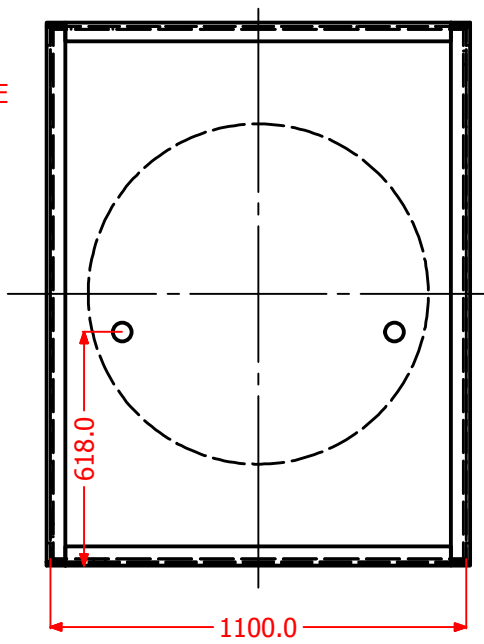
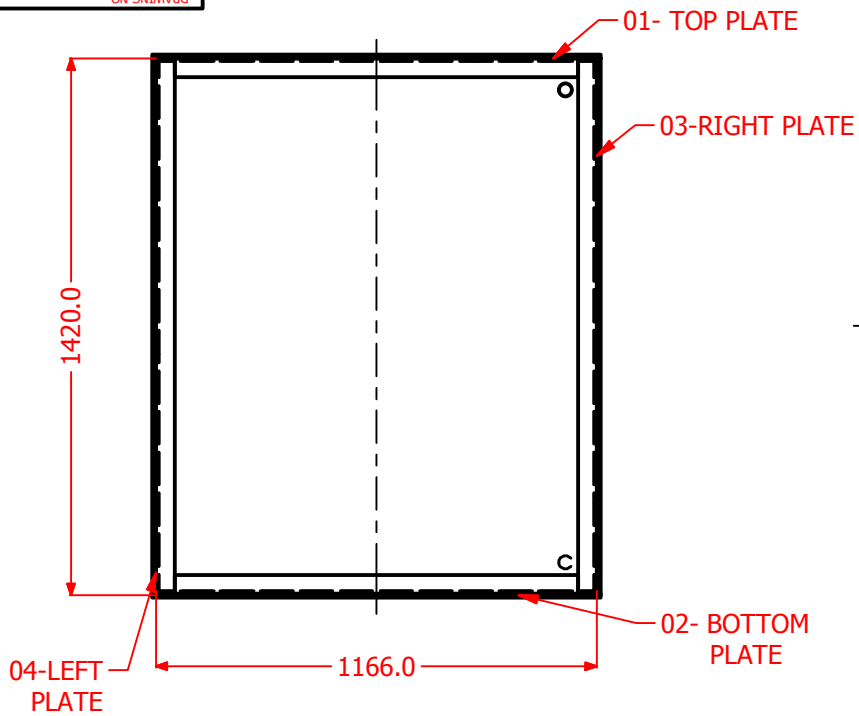

NOTE :

1. ALL 6 PLATES ARE ACRYLIC WELDED TO FORM CUBICLE AS SHOWN. REFER DRAWING RDDG434026\_1101 FOR ALL SHEETS.
2. ALL ACRYLIC WELDED JOINTS ARE COMPLETELY LEAK PROOF. NO LEAKAGE OF OIL FROM WELDED JOINTS.
3. 24 STIFFNERS ARE ACRYLIC WELDED TO CUBICLE FOR REINFORCEMENT AS SHOWN.

07	STIFFNERS	RDDG434026_1107	ACRYLIC		24
01-06	PLATES	RDDG434026_1101 to 06	ACRYLIC		06
REMARKS	VAR. NO.	ITEM NO.	DESCRIPTION	DRAWING NO.	UNIT WT.
					QTY.

ADDITIONAL INFORMATION		TYPE OF PRODUCT OPTIMIZATION OF LEAD INSULATION FOR POWER TRANSFORMERS OR NAME OF CUSTOMER / PROJECT			
STATUS OF DRAWING		BHARAT HEAVY ELECTRICALS LTD. CORPORATE R&D			
DISTRIBUTION OF PRINTS		DRN.	MISHRA	SIGN	DATE
R&D	HVE	QCX			12/2/2021
1	1	1			12/14/2021
DEPT	UNTOL. DIMS. GR.	SCALE	WEIGHT (KG.)	REF. TO. ASSY. DRG.	ITEM NO.
HVE		1 : 1	110.577 kg	RDDG434026_1000	
CODE					
34					
TITLE		DRAWING NO.			
BASE CELL		RDDG434026_1100			
		SHEET NO.		NO. OF SHEETS	

INVENTORY NO. SIGN. & DATE REF. DRG. NO. THE INFORMATION ON THIS DOCUMENT IS THE PROPERTY OF BHARAT HEAVY ELECTRICALS LIMITED. IT IS NOT TO BE DISSEMINATED OR REPRODUCED WITHOUT THE WRITTEN PERMISSION OF THE COMPANY.

REV.	DATE	ALTERED	REV.	DATE	ALTERED	REV.	DATE	ALTERED	REV.	DATE	ALTERED	REV.	DATE	ALTERED
		CHECKED			CHECKED			CHECKED			CHECKED			CHECKED
		APPROVED			APPROVED			APPROVED			APPROVED			APPROVED
ZONE			ZONE			ZONE			ZONE			ZONE		

DRAWING NO. RDDG434026\_1101 TO 1106

G-G (1 : 25)

E-E (1 : 25)

(~3.2)

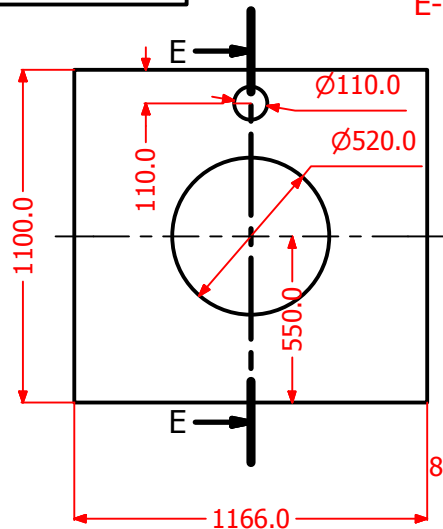

01. TOP PLATE - 1 NO.  
RDDG434026\_1101

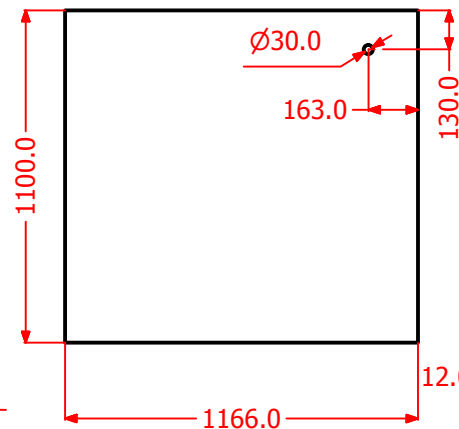

02. BOTTOM PLATE - 1 NO.  
RDDG434026\_1102

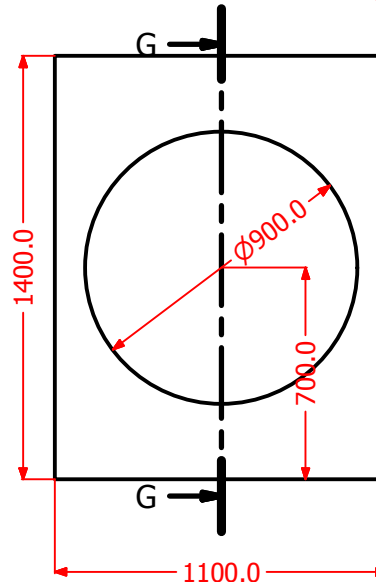

03. RIGHT PLATE - 1 NO.  
RDDG434026\_1103

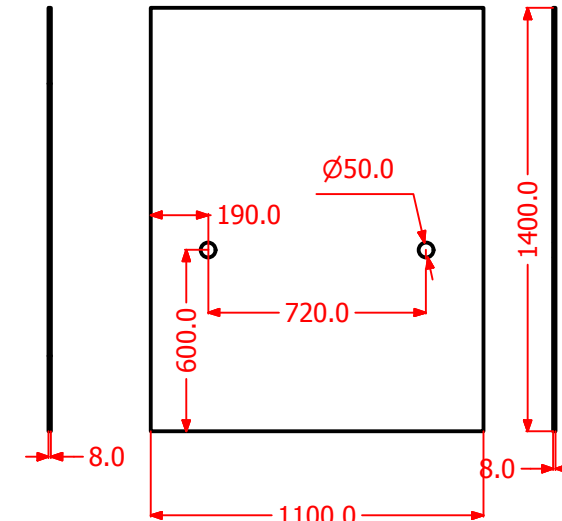

04. LEFT PLATE - 1 NO.  
RDDG434026\_1104

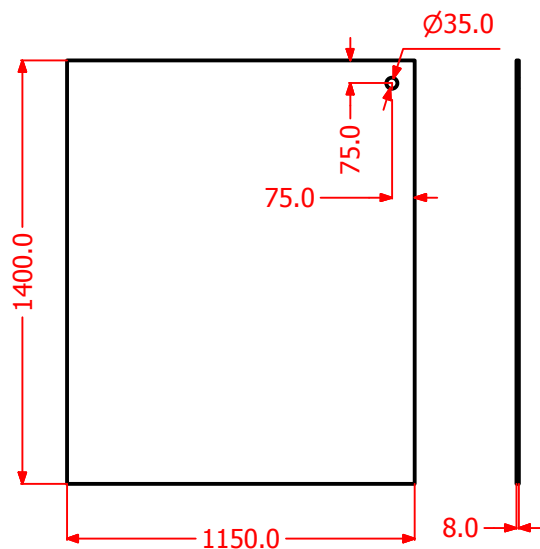

05. FRONT PLATE - 1 NO.  
RDDG434026\_1105

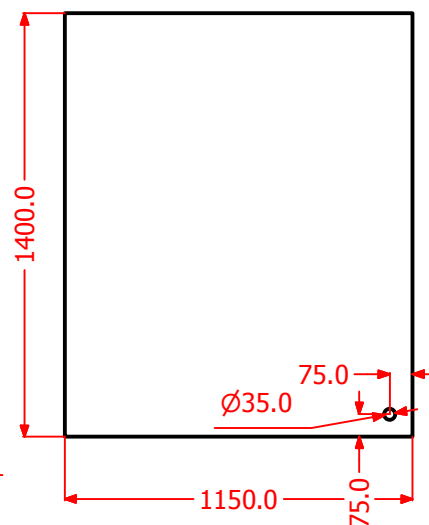

06. BACK PLATE - 1 NO.  
RDDG434026\_1106

REMARKS	VAR. NO.	ITEM NO.	DESCRIPTION	DRAWING NO.	STD.	Acrylic, Clear	UNIT	KG	UNIT WT.	QTY.	CS	ZONE
		01	SHEETS	-								

ADDITIONAL INFORMATION			
STATUS OF DRAWING			
DISTRIBUTION OF PRINTS			
R&D	HVE	QCX	
1	1	1	

TYPE OF PRODUCT OPTIMIZATION OF LEAD INSULATION FOR POWER TRANSFORMERS  
OR  
NAME OF CUSTOMER / PROJECT

DRN.	MISHRA	SIGN	DATE	NO. OF VAR.
CKD.	APC		12/18/2021	
APPD	SNK		12/18/2021	

DEPT	UNTOL. DIMS. GR.	SCALE	WEIGHT (KG.)	REF. TO. ASSY. DRG.	ITEM NO.	NO. OF ITEM
HVE		1 : 1		RDDG434026_1100		
CODE	34					

TITLE	DRAWING NO.	REV
PLATES	RDDG434026_1101 TO 1106	
	SHEET NO.	NO. OF SHEETS

REV.	DATE	ALTERED	REV.	DATE	ALTERED	REV.	DATE	ALTERED	REV.	DATE	ALTERED	REV.	DATE	ALTERED
		CHECKED			CHECKED			CHECKED			CHECKED			CHECKED
		APPROVED			APPROVED			APPROVED			APPROVED			APPROVED
ZONE			ZONE			ZONE			ZONE			ZONE		

INVENTORY NO. SIGN. & DATE REF. DRG. NO. THE INFORMATION ON THIS DOCUMENT IS THE PROPERTY OF BHARAT HEAVY ELECTRICALS LIMITED. IT IS NOT TO BE REPRODUCED OR TRANSMITTED IN ANY FORM OR BY ANY MEANS, ELECTRONIC OR MECHANICAL, INCLUDING PHOTOCOPYING, RECORDING, OR BY ANY INFORMATION STORAGE AND RETRIEVAL SYSTEM.

DRAWING NO. RDDG434026\_1107

(~3.2)

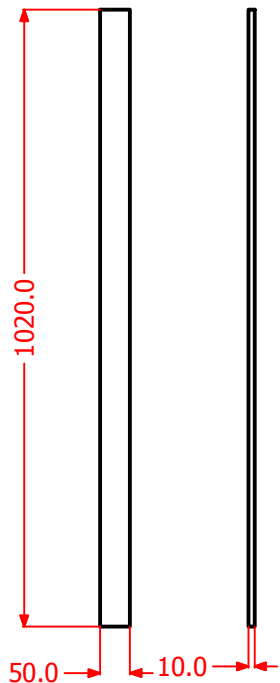

01. STIFFNER  
QTY : 8 NOS.

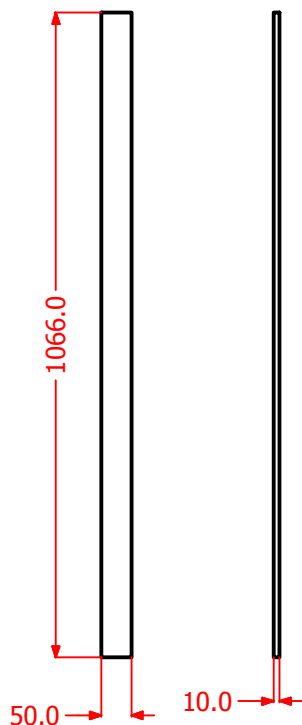

02. STIFFNER  
QTY : 4 NOS.

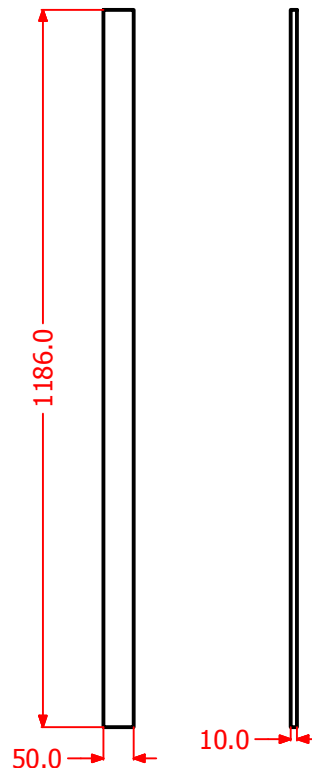

03. STIFFNER  
QTY : 4 NOS.

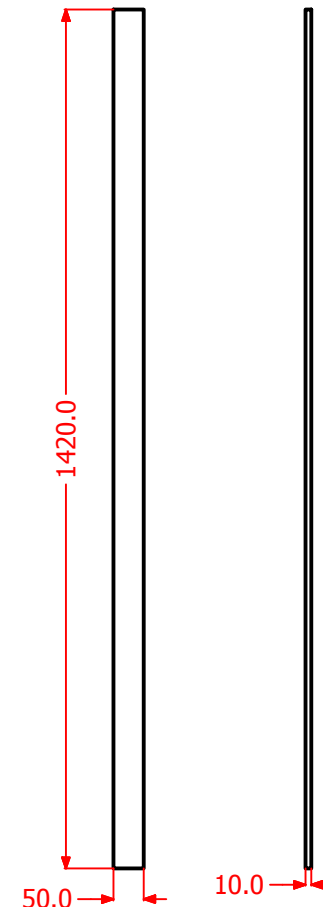

04. STIFFNER  
QTY : 8 NOS.

REMARKS	VAR. NO.	ITEM NO.	DESCRIPTION	DRAWING NO.	STD.	10MM THK	ACRYLIC	UNIT	KG	UNIT WT.	QTY.	CS	ZONE

ADDITIONAL INFORMATION				TYPE OF PRODUCT OPTIMIZATION OF LEAD INSULATION FOR POWER TRANSFORMERS OR				
STATUS OF DRAWING				NAME OF CUSTOMER / PROJECT				
DISTRIBUTION OF PRINTS				BHARAT HEAVY ELECTRICALS LTD. CORPORATE R&D				
R&D	HVE	QCX		DRN.	MISHRA	SIGN	DATE	NO. OF VAR
1	1	1		CKD.	APC		12/17/2023	
				APPD	SNK		12/18/2021	
DEPT	HVE	UNTOL. DIMS. GR.	SCALE	WEIGHT (KG.)	REF. TO. ASSY. DRG.	ITEM NO.	NO. OF ITEM	
34			1 : 1	0.606 kg	RDDG434026_1100			
TITLE				DRAWING NO.				
STIFFNERS				RDDG434026_1107				
				SHEET NO.		NO. OF SHEETS		

REV.	DATE	ALTERED	REV.	DATE	ALTERED	REV.	DATE	ALTERED	REV.	DATE	ALTERED	REV.	DATE	ALTERED
		CHECKED			CHECKED			CHECKED			CHECKED			CHECKED
ZONE		APPROVED	ZONE		APPROVED	ZONE		APPROVED	ZONE		APPROVED	ZONE		APPROVED

INVENTORY NO. SIGN. & DATE REF. DRG. NO.

THE INFORMATION ON THIS DOCUMENT IS THE PROPERTY OF BHARAT HEAVY ELECTRICALS LIMITED. IT MUST NOT BE DISCLOSED TO ANY UNAUTHORIZED PERSONNEL OR TO THE PUBLIC AT LARGE.

DRAWING NO. RDDG434026\_1001

A-A ( 0.15 : 1 )

(~3.2)

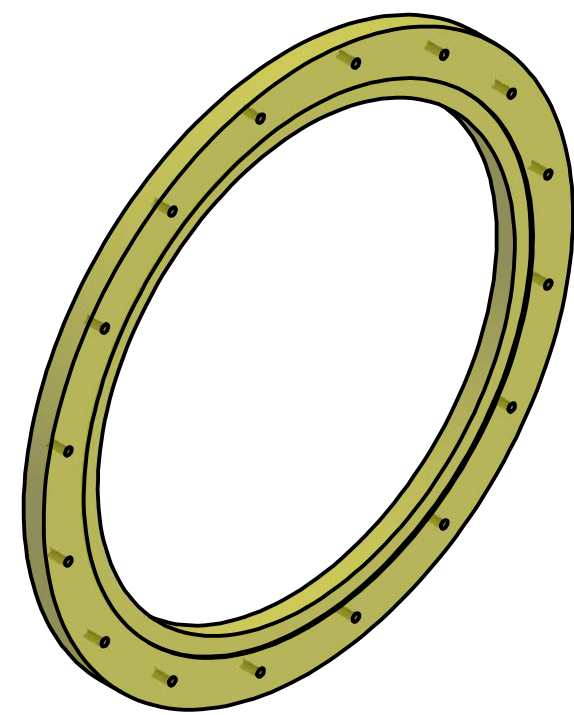
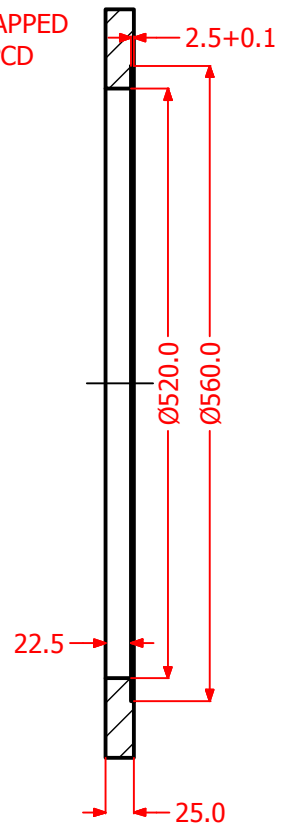
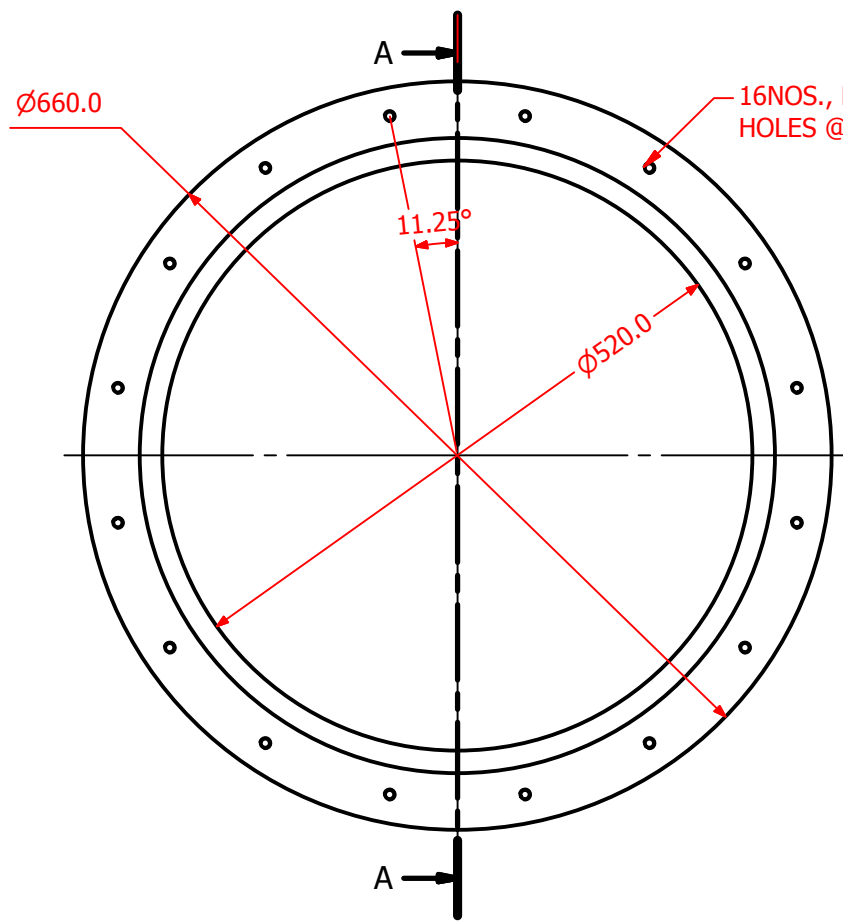

NOTE : ALL SHARP CORNERS ARE CHAMFERED TO 0.8X45°

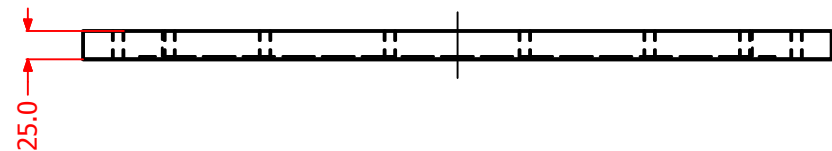

01 SHEET		DIA 660 X 25MM THK		Acrylic, Clear		3.733 kg	
REMARKS	VAR. NO.	ITEM NO.	DESCRIPTION	DRAWING NO.	FT. NO.	MATL. CODE	UNIT WT.
					VAR.	MATL. SPCN.	QTY.

ADDITIONAL INFORMATION				TYPE OF PRODUCT OPTIMIZATION OF LEAD INSULATION FOR POWER TRANSFORMERS OR			
STATUS OF DRAWING				NAME OF CUSTOMER / PROJECT			
DISTRIBUTION OF PRINTS				BHARAT HEAVY ELECTRICALS LTD. CORPORATE R&D			
R&D	HVE	QCX		DRN.	MISHRA	SIGN	DATE
1	1	1		CKD.	APC		12/2/2021
				APPD	SNK		12/18/2021
REV.	DATE	ALTERED	REV.	DATE	ALTERED	REV.	DATE
		CHECKED			CHECKED		
		APPROVED			APPROVED		
DEPT HVE				UNTL. DIMS. GR.	SCALE	WEIGHT (KG.)	REF. TO. ASSY. DRG.
34					1 : 1	3.733 kg	RDDG434026_1000
CODE				TITLE		ITEM NO. NO. OF ITEM	
				TOP BASE FLANGE		RDDG434026_1001	
INVENTORY NO.				DRAWING NO.		REV	
						SHEET NO. NO. OF SHEETS	

REV.	DATE	ALTERED	REV.	DATE	ALTERED	REV.	DATE	ALTERED	REV.	DATE	ALTERED	REV.	DATE	ALTERED	
		CHECKED			CHECKED			CHECKED			CHECKED			CHECKED	
		APPROVED			APPROVED			APPROVED			APPROVED			APPROVED	
ZONE		ZONE		ZONE		ZONE		ZONE		ZONE		ZONE		ZONE	

INVENTORY NO. SIGN. & DATE REF. DRG. NO. THE INFORMATION ON THIS DOCUMENT IS THE PROPERTY OF BHARAT HEAVY ELECTRICALS LIMITED. IT MUST NOT BE DISSEMINATED TO UNAUTHORIZED PERSONNEL WITHOUT THE APPROVAL OF THE COMPANY.

DRAWING NO. RDDG434026\_1002

A-A ( 0.1 : 1 )

(~3.2)

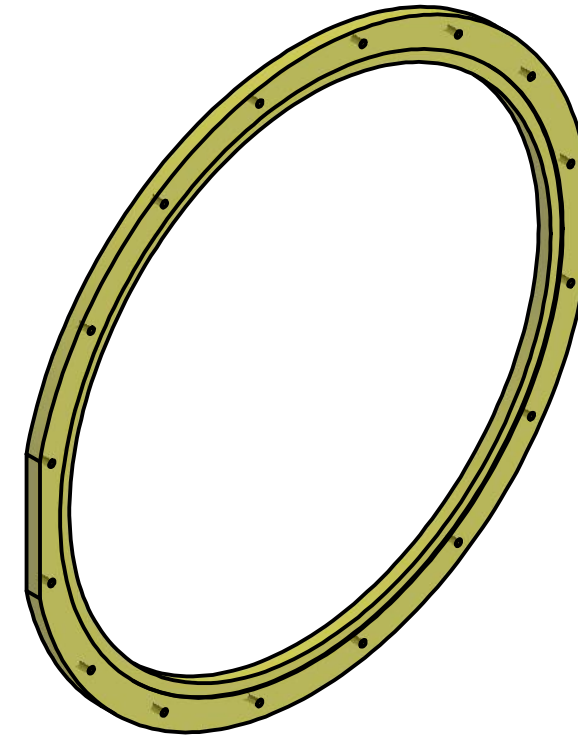
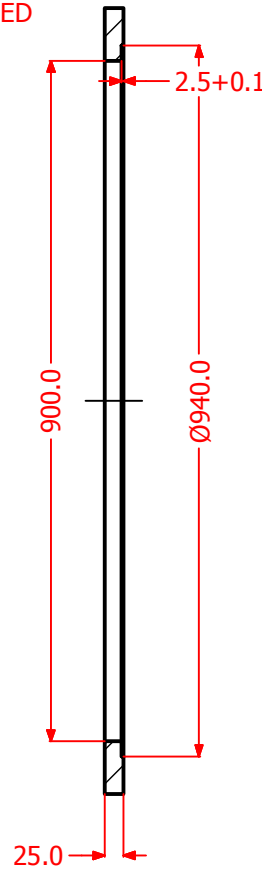
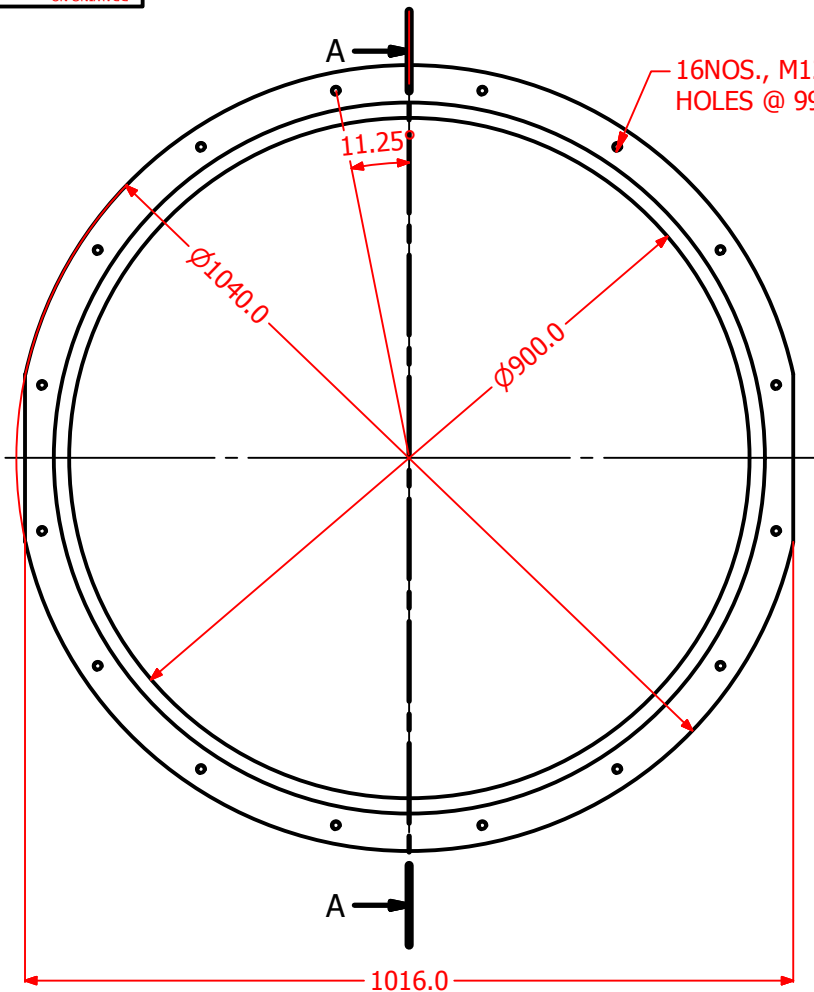

NOTE : ALL SHARP CORNERS ARE CHAMFERED TO 0.8X45°



01 SHEET		DIA 960 X 25MM THK		Acrylic, Clear		6.030 kg	
REMARKS	VAR. NO.	ITEM NO.	DESCRIPTION	DRAWING NO.	MT. NO.	MATL. CODE	UNIT WT.
					VAR.	MATL. SPCN.	QTY.

ADDITIONAL INFORMATION				TYPE OF PRODUCT OPTIMIZATION OF LEAD INSULATION FOR POWER TRANSFORMERS OR			
STATUS OF DRAWING				NAME OF CUSTOMER / PROJECT			
DISTRIBUTION OF PRINTS				BHARAT HEAVY ELECTRICALS LTD. CORPORATE R&D			
R&D	HVE	QCX		DRN.	MISHRA	SIGN	DATE
1	1	1		CKD.	APC		12/2/2021
				APPD	SNK		12/18/2021
REV.	DATE	ALTERED	REV.	DATE	ALTERED	REV.	DATE
		CHECKED			CHECKED		
		APPROVED			APPROVED		
DEPT HVE				UNTL. DIMS. GR.	SCALE	WEIGHT (KG.)	REF. TO. ASSY. DRG.
34					1 : 1	6.030 kg	RDDG434026_1000
TITLE				SIDE BASE FLANGE			
DRAWING NO.				RDDG434026_1002			
SHEET NO.				NO. OF SHEETS			

REV.	DATE	ALTERED	REV.	DATE	ALTERED	REV.	DATE	ALTERED	REV.	DATE	ALTERED	REV.	DATE	ALTERED
		CHECKED			CHECKED			CHECKED			CHECKED			CHECKED
		APPROVED			APPROVED			APPROVED			APPROVED			APPROVED
ZONE			ZONE			ZONE			ZONE			ZONE		

INVENTORY NO. SIGN. & DATE REF. DRG. NO.

THE INFORMATION ON THIS DOCUMENT IS THE PROPERTY OF BHARAT HEAVY ELECTRICALS LIMITED. IT MUST NOT BE DISCLOSED TO ANY UNAUTHORIZED PERSON OR ORGANIZATION, TO THE INTEREST OF THE COMPANY.

A-A ( 0.15 : 1 )

(~3.2)

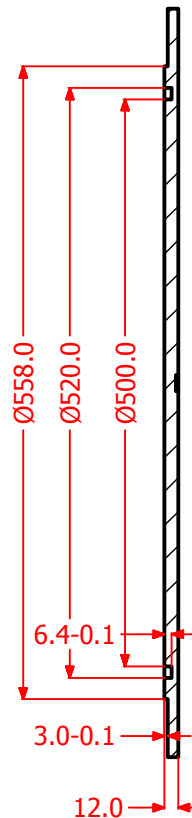
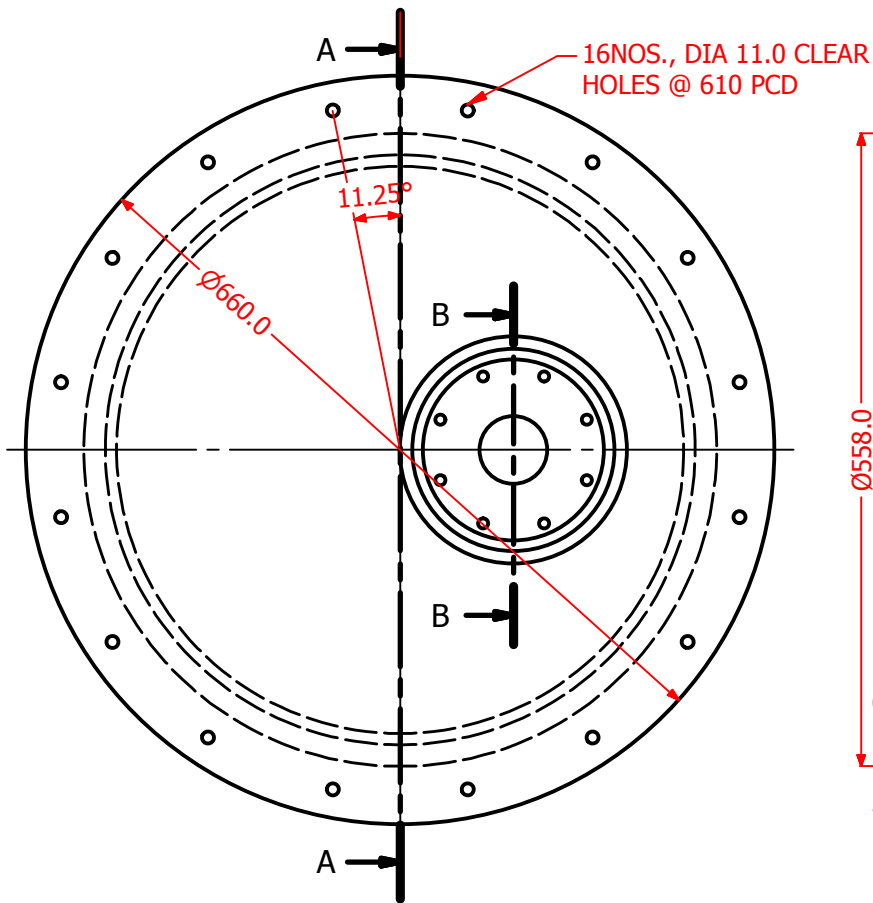

B-B ( 0.15 : 1 )

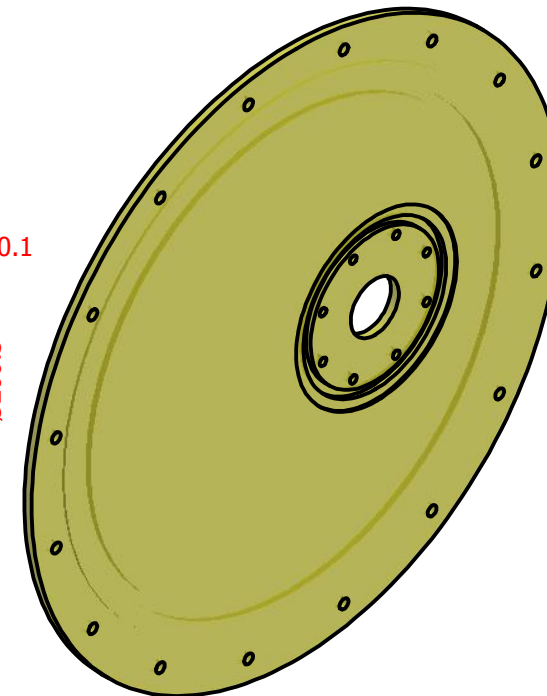
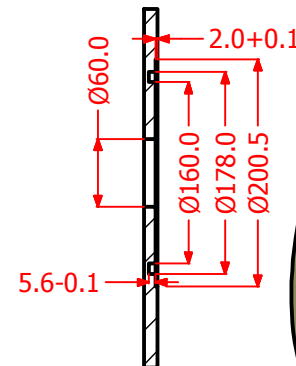

NOTE : ALL SHARP CORNERS ARE CHAMFERED TO 0.8X45°



01 SHEET		DIA 660 X 12MM THK		Acrylic, Clear		4.253 kg	
REMARKS	VAR. NO.	ITEM NO.	DESCRIPTION	DRAWING NO.	FT. NO.	MATL. CODE	UNIT WT.
					VAR.	MATL. SPCN.	QTY.

ADDITIONAL INFORMATION				TYPE OF PRODUCT OPTIMIZATION OF LEAD INSULATION FOR POWER TRANSFORMERS OR			
STATUS OF DRAWING				NAME OF CUSTOMER / PROJECT			
DISTRIBUTION OF PRINTS				BHARAT HEAVY ELECTRICALS LTD. CORPORATE R&D			
R&D	HVE	QCX		DRN.	MISHRA	SIGN	DATE
1	1	1		CKD.	APC		12/9/2021
				APPD	SNK		12/10/2021
REV.	DATE	ALTERED	REV.	DATE	ALTERED	REV.	DATE
		CHECKED			CHECKED		
		APPROVED			APPROVED		

DEPT	UNTOL. DIMS. GR.	SCALE	WEIGHT (KG.)	REF. TO. ASSY. DRG.	ITEM NO.	NO. OF ITEM
HVE		1 : 1	4.253 kg	RDDG434036_1000		
CODE				DRAWING NO.	REV	
34				RDDG434036_1003		
TITLE				SHEET NO.		
TOP COVER FLANGE				NO. OF SHEETS		

REV.	DATE	ALTERED	REV.	DATE	ALTERED	REV.	DATE	ALTERED	REV.	DATE	ALTERED
		CHECKED			CHECKED			CHECKED			CHECKED
		APPROVED			APPROVED			APPROVED			APPROVED
ZONE			ZONE			ZONE			ZONE		

INVENTORY NO. SIGN. & DATE REF. DRG. NO.

THE INFORMATION ON THIS DOCUMENT IS THE PROPERTY OF BHARAT HEAVY ELECTRICALS LIMITED. IT MUST NOT BE DISCLOSED TO ANY UNAUTHORIZED PERSON OR ORGANIZATION, IN ANY MANNER OR BY ANY MEANS.

DRAWING NO. RDDG434026\_1004

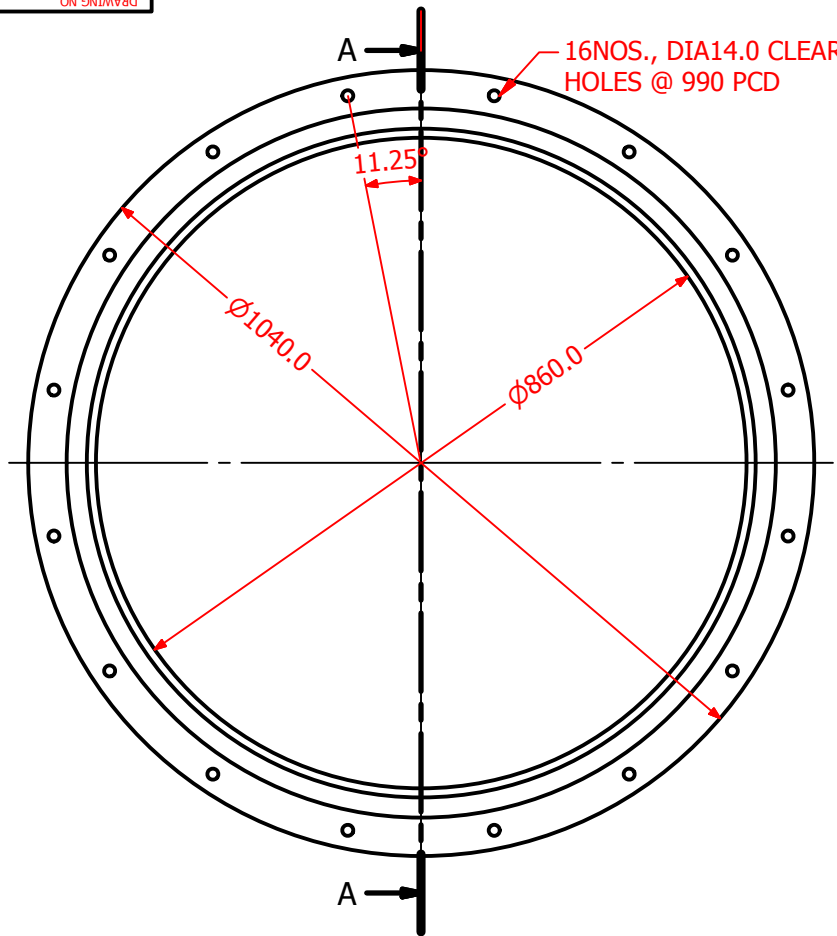

A-A ( 0.1 : 1 )

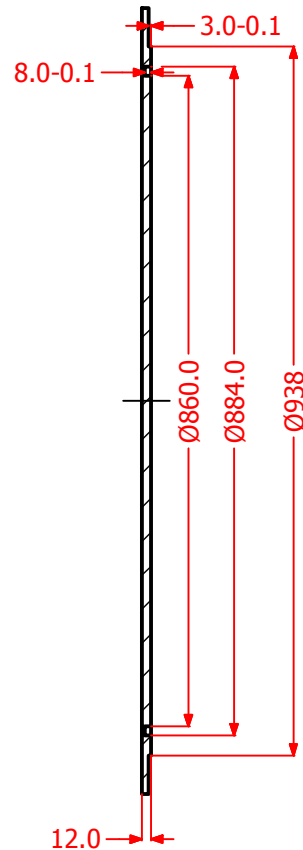

(~3.2)

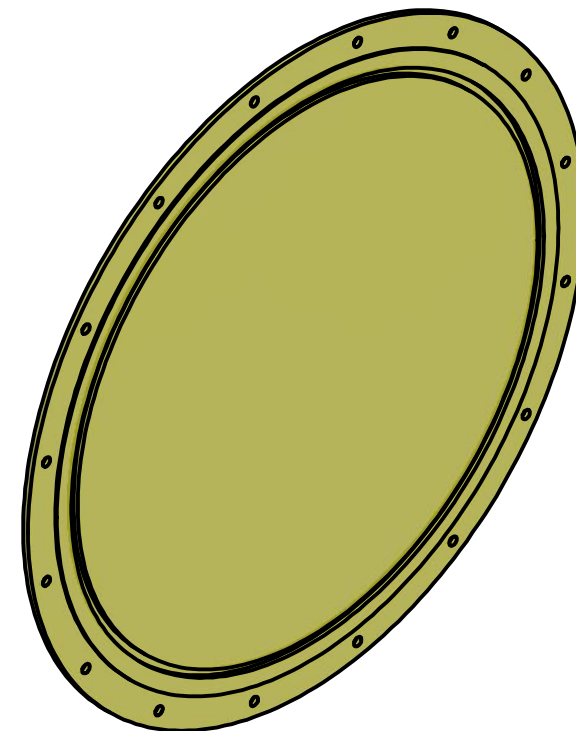

NOTE : ALL SHARP CORNERS ARE CHAMFERED TO 0.8X45°

THE INFORMATION ON THIS DOCUMENT IS THE PROPERTY OF BHARAT HEAVY ELECTRICALS LIMITED. IT MUST NOT BE DISCLOSED TO ANY UNAUTHORIZED PERSON OR ORGANIZATION, IN THE INTEREST OF THE COMPANY.

SIGN. & DATE

INVENTORY NO.

REF. DRG. NO.

01 SHEET		DIA 1040 X 12MM THK		Acrylic, Clear		11.226 kg	
REMARKS	VAR. NO.	ITEM NO.	DESCRIPTION	DRAWING NO.	MT. NO.	MATL. CODE	UNIT
					VAR.	MATL. SPCN.	QTY.

ADDITIONAL INFORMATION: TYPE OF PRODUCT OPTIMIZATION OF LEAD INSULATION FOR POWER TRANSFORMERS OR NAME OF CUSTOMER / PROJECT

STATUS OF DRAWING				DISTRIBUTION OF PRINTS				BHARAT HEAVY ELECTRICALS LTD. CORPORATE R&D				DRN. MISHRA	SIGN	DATE 12/2/2021	NO. OF VAR
R&D	HVE	QCX										CKD. APC		12/17/2021	
1	1	1										APPD. SNK		12/17/2021	

REV.	DATE	ALTERED	REV.	DATE	ALTERED	REV.	DATE	ALTERED	REV.	DATE	ALTERED	REV.	DATE	ALTERED	REV.	DATE	ALTERED	DEPT. HVE	UNTL. DIMS. GR.	SCALE	WEIGHT (KG.)	REF. TO. ASSY. DRG.	ITEM NO.	NO. OF ITEM
		CHECKED			CHECKED			CHECKED			CHECKED			CHECKED			CHECKED	34		1 : 1	11.226 kg	RDDG434026_1000		
		APPROVED			APPROVED			APPROVED			APPROVED			APPROVED			APPROVED					RDDG434026_1004		
ZONE			ZONE			ZONE			ZONE			ZONE			ZONE							DRAWING NO.	REV	
																						SHEET NO.	NO. OF SHEETS	

SIDE COVER FLANGE

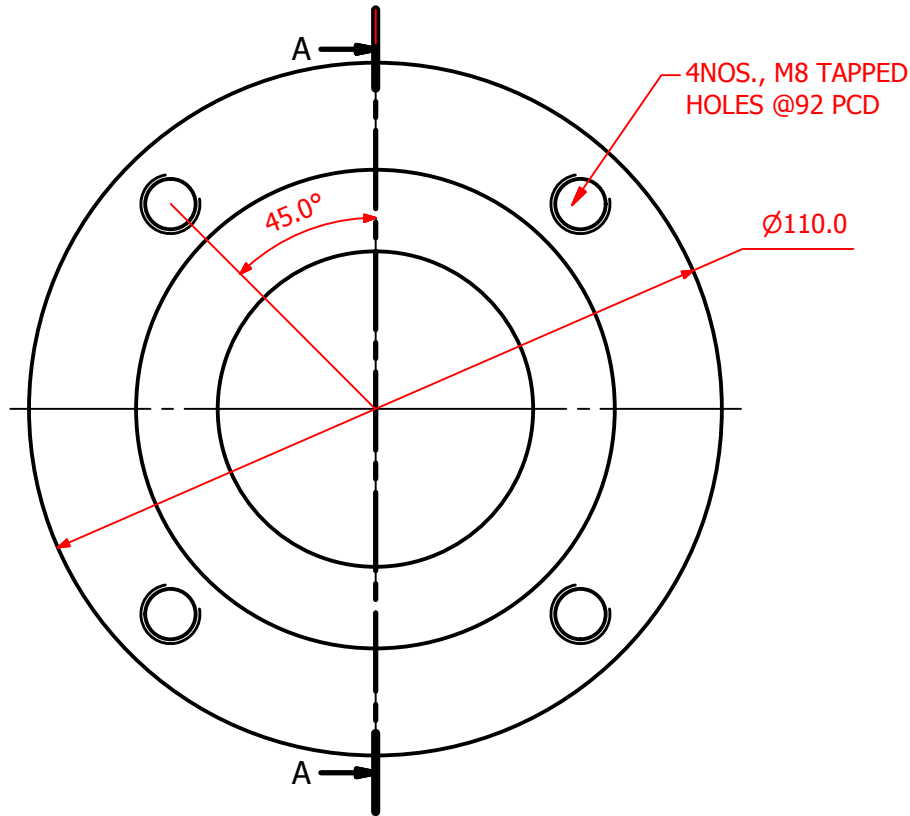

A-A ( 1 : 1.2 )

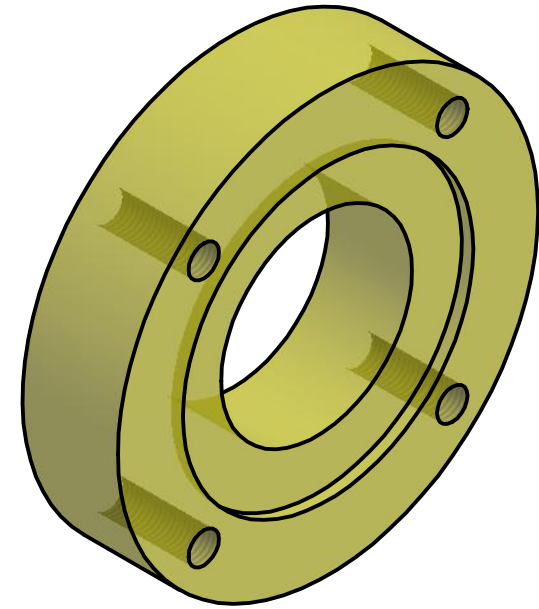
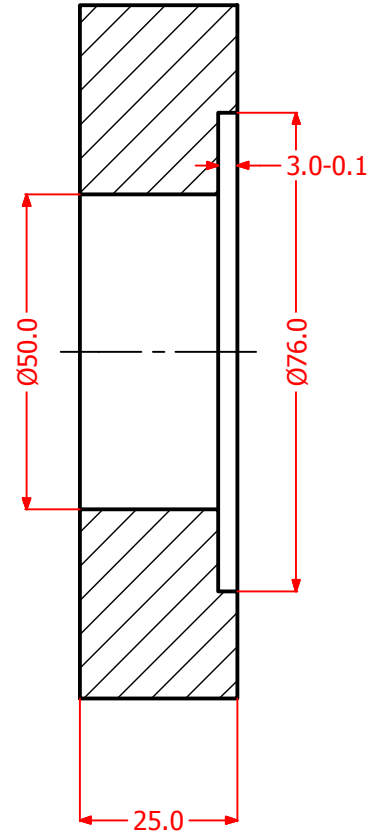

NOTE : ALL SHARP CORNERS ARE CHAMFERED TO 0.8X45°

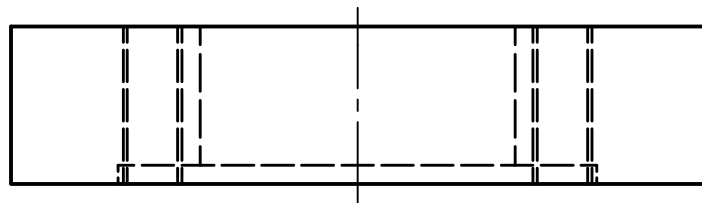

01	ROD	DIA 110 X 25MM THK	Acrylic, Clear	0.209 kg
REMARKS	VAR. NO.	ITEM NO.	DESCRIPTION	DRAWING NO.

ADDITIONAL INFORMATION		TYPE OF PRODUCT OPTIMIZATION OF LEAD INSULATION FOR POWER TRANSFORMERS OR NAME OF CUSTOMER / PROJECT			
STATUS OF DRAWING		BHARAT HEAVY ELECTRICALS LTD. CORPORATE R&D			
DISTRIBUTION OF PRINTS		DRN.	MISHRA	SIGN	DATE
R&D	HVE	QCX			12/2/2021
1	1	1			12/18/2021
DEPT	UNTOL. DIMS. GR.	SCALE	WEIGHT (KG.)	REF. TO. ASSY. DRG.	ITEM NO.
HVE		1 : 1	0.209 kg	RDDG434026_1000	
CODE					
34					
TITLE		DRAWING NO.			
FLANGE_BACK		RDDG434026_1005			
		SHEET NO.		NO. OF SHEETS	

REV.	DATE	ALTERED	REV.	DATE	ALTERED	REV.	DATE	ALTERED	REV.	DATE	ALTERED
		CHECKED			CHECKED			CHECKED			CHECKED
		APPROVED			APPROVED			APPROVED			APPROVED
ZONE			ZONE			ZONE			ZONE		

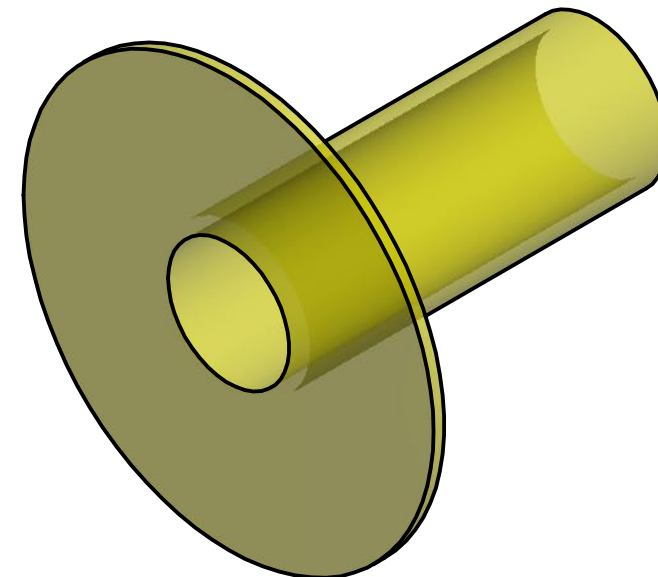
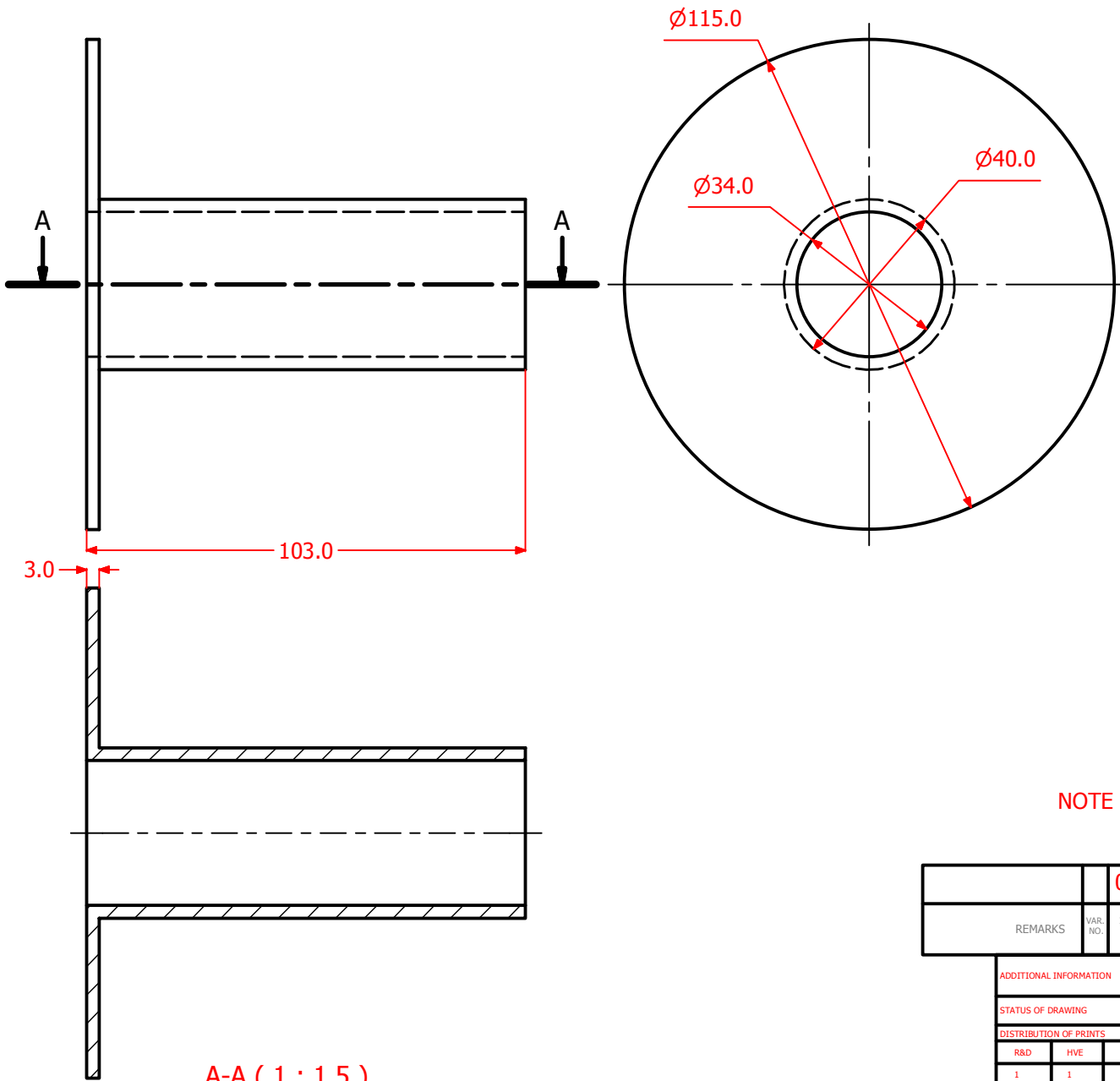

NOTE : ALL SHARP CORNERS ARE CHAMFERED TO 0.8X45°

VAR. NO.	01	ITEM NO.	ROD	DESCRIPTION	DIA 115 X 103 MM LEN	MATL. CODE	Acrylic, Clear	UNIT WT.	0.075 kg
REMARKS				DRAWING NO.		MATL. SPCN.		QTY.	

ADDITIONAL INFORMATION				TYPE OF PRODUCT OPTIMIZATION OF LEAD INSULATION FOR POWER TRANSFORMERS OR NAME OF CUSTOMER / PROJECT							
STATUS OF DRAWING				BHARAT HEAVY ELECTRICALS LTD. CORPORATE R&D							
DISTRIBUTION OF PRINTS				DRN.	MISHRA	SIGN		DATE	12/2/2021	NO. OF VAR	
R&D	HVE	QCX		CKD.	APC				12/18/2021		
1	1	1		APPD	SNK				12/18/2021		
DEPT	HVE	UNTOL. DIMS. GR.	SCALE	WEIGHT (KG.)	REF. TO. ASSY. DRG.	ITEM NO.	NO. OF ITEM				
34			1 : 1	0.075 kg	RDDG434026_1000						
TITLE				DRAWING NO.							
INLET / OUTLET PIPE				RDDG434026_1006							
				SHEET NO.				NO. OF SHEETS			

A-A (1:15)

REV.	DATE	ALTERED	REV.	DATE	ALTERED	REV.	DATE	ALTERED	REV.	DATE	ALTERED
		CHECKED			CHECKED			CHECKED			CHECKED
		APPROVED			APPROVED			APPROVED			APPROVED
ZONE			ZONE			ZONE			ZONE		

( ALL DIMENSIONS ARE IN mm )

(~3.2)

AA (1:2.5)

DRAWING NO. RDDG434026\_1007

FIRST ANGLE PROJECTION

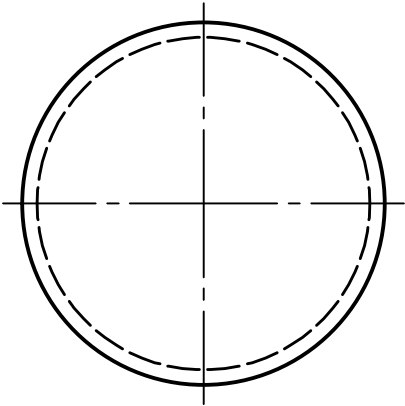
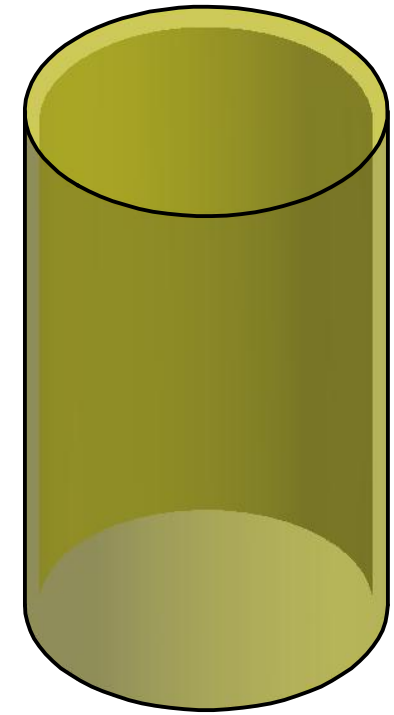
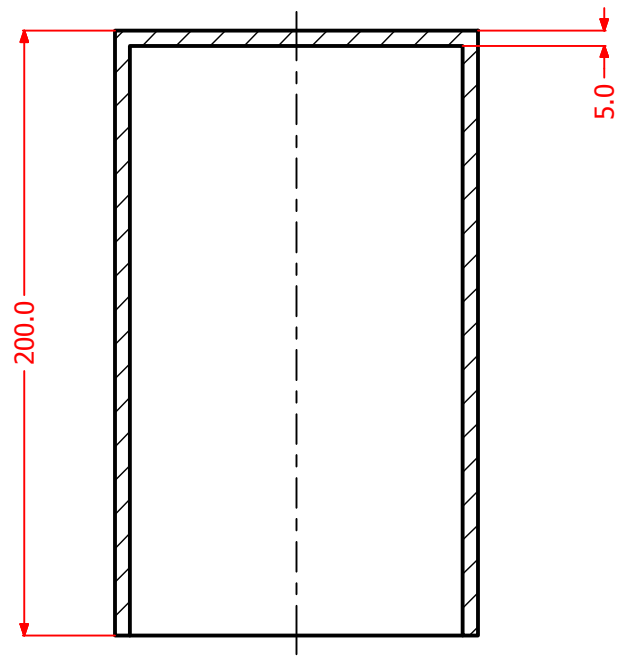
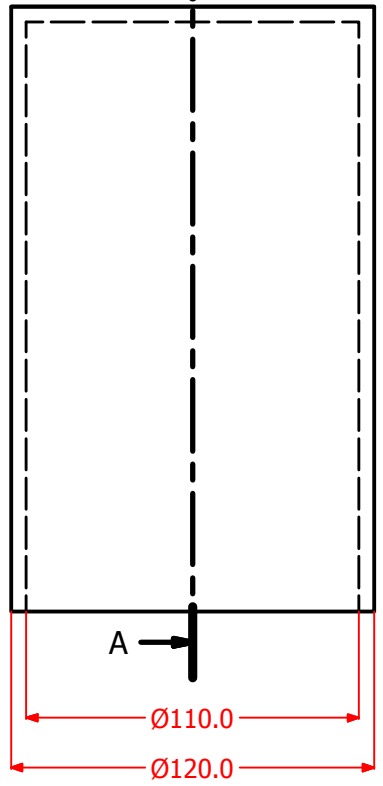

REMARKS	VAR. NO.	ITEM NO.	DESCRIPTION	DRAWING NO.	STD.	UNIT WT.	QTY.	CS	ZONE
		01	ROD	DIA 120 X 200MM LBN		Acrylic, Clear	0.486 kg		

ADDITIONAL INFORMATION		TYPE OF PRODUCT OPTIMIZATION OF LEAD INSULATION FOR POWER TRANSFORMERS OR NAME OF CUSTOMER / PROJECT							
STATUS OF DRAWING		BHARAT HEAVY ELECTRICALS LTD. CORPORATE R&D							
DISTRIBUTION OF PRINTS		DRN.	MISHRA	SIGN	DATE	NO. OF VAR			
R&D	HVE	QCX			12/18/2021		CKD.	APC	
1	1	1					APPD	SNK	12/18/2021
REV.	DATE	ALTERED	REV.	DATE	ALTERED	REV.	DATE	ALTERED	REV.
		CHECKED			CHECKED			CHECKED	
		APPROVED			APPROVED			APPROVED	
DEPT	HVE	UNTOL. DIMS. GR.	SCALE	WEIGHT (KG.)	REF. TO. ASSY. DRG.	ITEM NO.	NO. OF ITEM		
34			1 : 1	0.486 kg	RDDG434026_1000				
TITLE		DRAWING NO.		REV					
BREATHER		RDDG434026_1007							
SHEET NO.		NO. OF SHEETS							

REV.	DATE	ALTERED	REV.	DATE	ALTERED	REV.	DATE	ALTERED	REV.	DATE	ALTERED
		CHECKED			CHECKED			CHECKED			CHECKED
		APPROVED			APPROVED			APPROVED			APPROVED
ZONE			ZONE			ZONE			ZONE		

INVENTORY NO. SIGN. & DATE REF. DRG. NO.

THE INFORMATION ON THIS DOCUMENT IS THE PROPERTY OF BHARAT HEAVY ELECTRICALS LIMITED. IT MUST NOT BE DISSEMINATED TO ANY OTHERS WITHOUT THE PERMISSION OF THE COMPANY.

A-A ( 1 : 1.2 )

(~3.2)

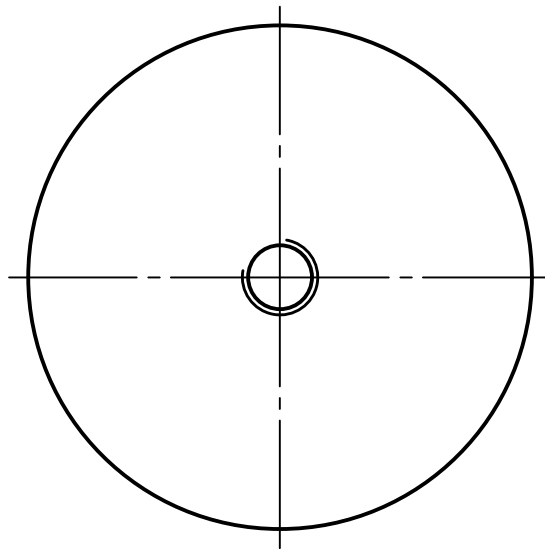
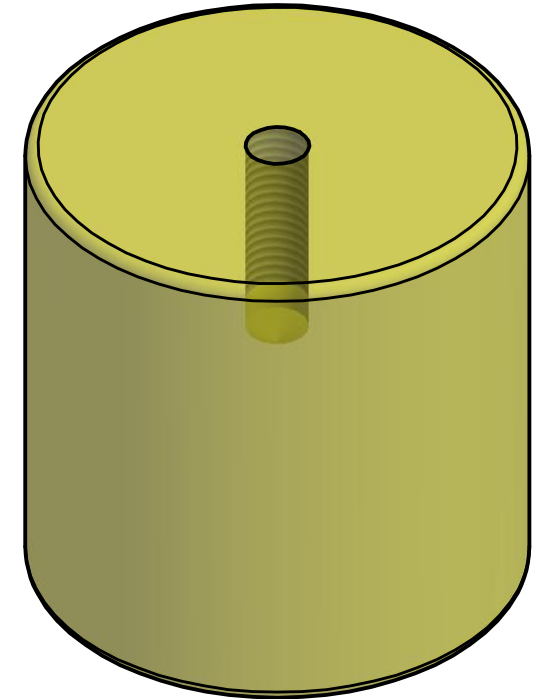
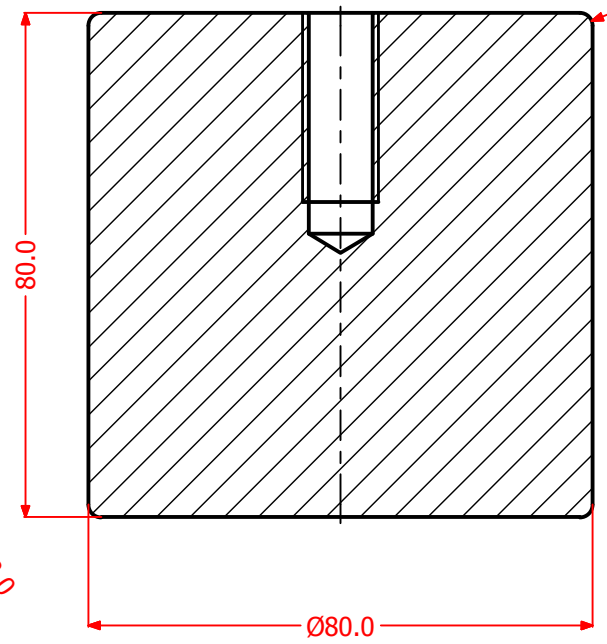
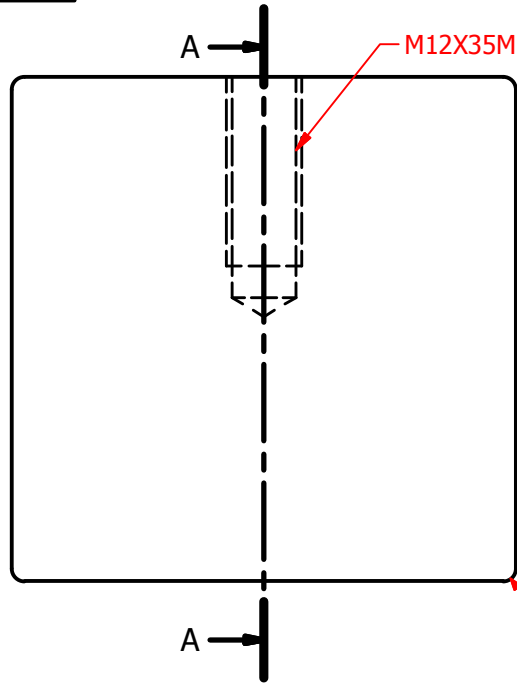

01	ROD	DIA 80 X 80MM LEN	PMMA Plastic	0.474 kg
REMARKS	VAR. NO.	ITEM NO.	DESCRIPTION	DRAWING NO.

ADDITIONAL INFORMATION		TYPE OF PRODUCT OPTIMIZATION OF LEAD INSULATION FOR POWER TRANSFORMERS OR NAME OF CUSTOMER / PROJECT			
STATUS OF DRAWING		BHARAT HEAVY ELECTRICALS LTD. CORPORATE R&D			
DISTRIBUTION OF PRINTS		DRN.	MISHRA	SIGN	DATE
R&D	HVE	QCX			12/17/2021
1	1	1			12/18/2021
DEPT	HVE	UNTOL. DIMS. GR.	SCALE	WEIGHT (KG.)	REF. TO. ASSY. DRG.
34			1 : 1	0.474 kg	RDDG434026_1000
TITLE		DRAWING NO.		ITEM NO.	NO. OF ITEM
SUPPORT BUSH		RDDG434026_1000			
		SHEET NO.		NO. OF SHEETS	

REV.	DATE	ALTERED	REV.	DATE	ALTERED	REV.	DATE	ALTERED	REV.	DATE	ALTERED
		CHECKED			CHECKED			CHECKED			CHECKED
		APPROVED			APPROVED			APPROVED			APPROVED
ZONE			ZONE			ZONE			ZONE		

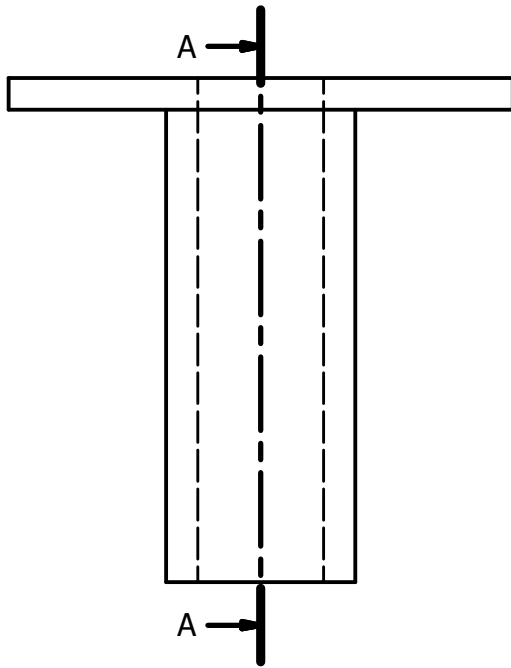

A-A ( 1 : 1.2 )

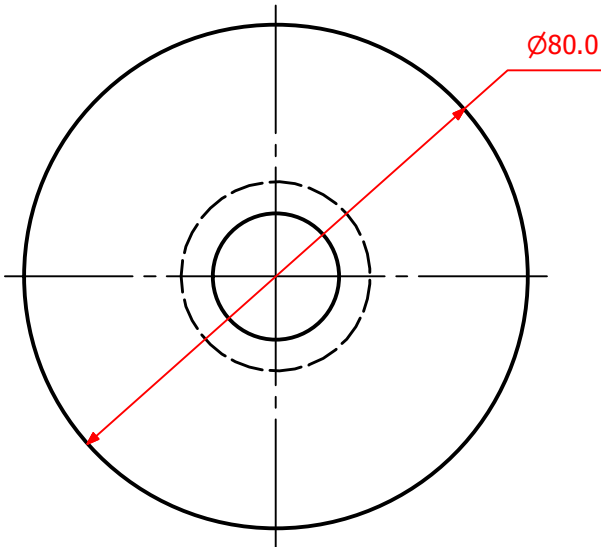
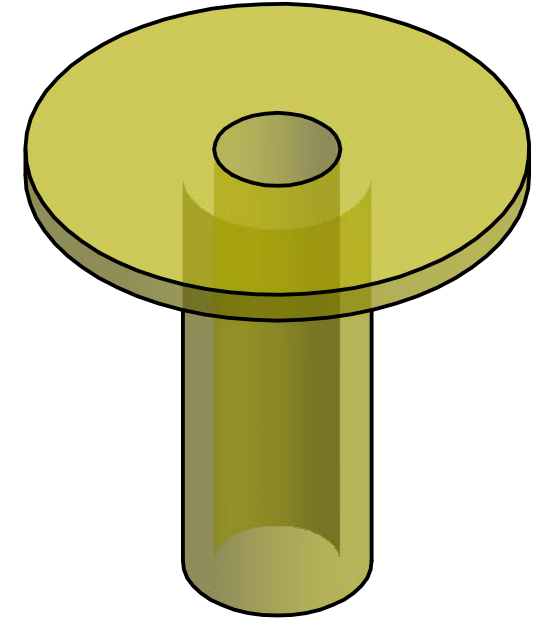
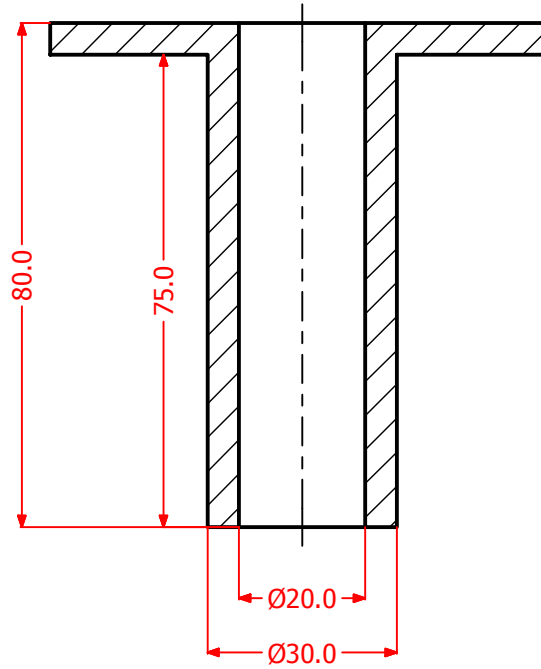

01	ROD	DIA 80 X 80MM LEN	PMMA Plastic	0.063 kg
REMARKS	VAR. NO.	ITEM NO.	DESCRIPTION	DRAWING NO.

ADDITIONAL INFORMATION		TYPE OF PRODUCT OPTIMIZATION OF LEAD INSULATION FOR POWER TRANSFORMERS OR NAME OF CUSTOMER / PROJECT			
STATUS OF DRAWING		BHARAT HEAVY ELECTRICALS LTD. CORPORATE R&D			
DISTRIBUTION OF PRINTS		DRN. MISHRA	SIGN	DATE 12/17/2023	NO. OF VAR
R&D	HVE	QCX			
1	1	1			
DEPT HVE	UNTO. DIMS. GR.	SCALE 1 : 1	WEIGHT (KG.) 0.063 kg	REF. TO. ASSY. DRG. RDDG434026_1000	ITEM NO.
34					
TITLE DRAIN BUSH		DRAWING NO. RDDG434026_1009		REV	
		SHEET NO.		NO. OF SHEETS	

REV.	DATE	ALTERED	REV.	DATE	ALTERED	REV.	DATE	ALTERED	REV.	DATE	ALTERED
		CHECKED			CHECKED			CHECKED			CHECKED
		APPROVED			APPROVED			APPROVED			APPROVED
ZONE			ZONE			ZONE			ZONE		